

## Use & Care Guide

## Manual de Uso y Cuidado

English / Español



System tested and certified by NSF International against NSF/ANSI Standard 44 for hardness reduction and efficiency.

Este sistema ha sido probado y certificado por NSF International de acuerdo a Norma NSF/ANSI 44 para la reducción de la dureza y eficiencia.

Model / Modelo No. 625.383000

# Kenmore® Water Softener

with High Flow Valve

# Ablandador de Agua con válvula de alto flujo

Sears Brands Management Corporation  
3333 Beverly Road  
Hoffman Estates, IL 60179 U.S.A.  
[www.kenmorewater.com](http://www.kenmorewater.com)  
[www.kenmore.com](http://www.kenmore.com)  
[www.sears.com](http://www.sears.com)



Printed on recycled paper /  
Impreso en papel reciclado

P/N 7324976 (Rev. B 1/31/11)

# Warranty

## WARRANTY ON KENMORE WATER SOFTENER

### ONE YEAR LIMITED WARRANTY ON WATER SOFTENER

When installed, operated and maintained according to all instructions supplied with the product, if this Kenmore appliance fails due to a defect in material and workmanship within one year from the date of purchase, call 1-800-4-MY-HOME® to arrange for free repair.

### TEN YEAR LIMITED WARRANTY AGAINST LEAKS

When installed, operated and maintained according to all instructions supplied with the product, if the water softener tank or salt storage drum develops a leak within ten years from the date of purchase, call 1-800-4-MY-HOME® to arrange for free tank or drum replacement. After the first year you must pay an initial trip charge.

All warranty coverage does not include water softener resin, which is an expendable item.

If this appliance is used for other than private family purposes, this warranty applies for only 90 days from the date of purchase.

**This warranty covers only defects in material and workmanship. Sears will NOT pay for:**

1. A service technician to instruct the user in correct product installation, operation or maintenance.
2. A service technician to clean or maintain this product.
3. Damage to or failure of this product if it is not installed, operated or maintained according to the all instructions supplied with the product.
4. Damage to or failure of this product resulting from accident, abuse, misuse or use for other than its intended purpose.
5. Damage to or failure of this product caused by the use of detergents, cleaners, chemicals or utensils other than those recommended in all instructions supplied with the product.
6. Damage to or failure of parts or systems resulting from unauthorized modifications made to this product.

### Disclaimer of implied warranties; limitation of remedies

Customer's sole and exclusive remedy under this limited warranty shall be product repair as provided herein. Implied warranties, including warranties of merchantability or fitness for a particular purpose, are limited to one year or the shortest period allowed by law. Sears shall not be liable for incidental or consequential damages. Some states and provinces do not allow the exclusion or limitation of incidental or consequential damages, or limitation on the duration of implied warranties of merchantability or fitness, so these exclusions or limitations may not apply to you.

This warranty applies only while this appliance is used in the United States or Canada.

This warranty gives you specific legal rights, and you may also have other rights which vary from state to state.

**Sears Brands Management Corporation, Hoffman Estates, IL 60179 U.S.A.**

# Table of Contents

Warranty .....	2
Safety Guides .....	3
Specifications & Dimensions .....	4
Packing List .....	5
Plan Your Installation .....	5-7
Installation .....	7-11
Programming the Softener .....	12-13
Sanitizing the Water Softener .....	14
Adding Salt to the Storage Tank .....	14
Controller Features .....	15-16
Care of Your Water Softener .....	17
Service Information .....	17-20
Exploded View & Parts List .....	22-25

## Safety Guides

- ▲ Read all steps and guides carefully before installing and using your new water softener. Follow all steps exactly to correctly install. Failure to follow them could cause personal injury or property damage. Reading this manual will also help you to get all the benefits from your water softener.
  - ▲ Your Kenmore water softener will remove hardness minerals from water. This is measured in grains per gallon (gpg). It will also remove some clear water iron\*. This is measured in parts per million (ppm). See the specifications page for the maximum limits of hardness and iron removal.
  - ▲ A water softener will not improve other water problems such as acidity, tastes and odors, or iron other than clear water iron.
  - ▲ Do not attempt to use this product to make safe drinking water from non-potable water sources. Do not use the system on microbiologically unsafe water, or water of unknown quality without adequate disinfection before or after the system.
  - ▲ Check with your local public works department for plumbing and sanitation codes. You must follow their guides as you install the system. Follow your local codes if they differ with guides in this manual. In Massachusetts, plumbing code 248-CMR 3.00 and 10.00 shall be adhered to. Consult with a licensed plumber.
  - ▲ Use only lead-free solder and flux for all sweat-solder connections, as required by federal codes, when installing soldered copper plumbing.
  - ▲ Use care when handling the water softener. Do not turn upside down or drop.
  - ▲ Avoid installing in direct sunlight. Excessive heat may cause distortion or other damage to non-metallic parts.
  - ▲ This water softener works on water pressures of 20 psi (minimum) to 125 psi (maximum). If your house water pressure is over the maximum, install a pressure reducing valve in the water supply pipe to the softener.
  - ▲ Temperature of the water supply to the softener must be between 40°F and 120°F. Do not install on hot water.
  - ▲ If installing the water softener outdoors, do not locate where it will be exposed to wet weather, direct sunlight or extreme hot or cold temperatures.
  - ▲ This softener works on 24 volt, 60 Hz electrical power only, supplied by a direct plug-in transformer (included). Be sure to use the included transformer and plug it into a nominal 120V, 60 cycle household outlet that is properly protected by an overcurrent device such as a circuit breaker or fuse. If transformer is replaced, use only the authorized service, Class II, 24V 10VA transformer.
- \* The capacity to reduce clear water iron is substantiated by Water Quality Association test data.



European Directive 2002/96/EC requires all electrical and electronic equipment to be disposed of according to Waste Electrical and Electronic Equipment (WEEE) requirements. This directive or similar laws are in place nationally and can vary from region to region. Please refer to your state and local laws for proper disposal of this equipment.

# Specifications & Dimensions

	<b>Model No. 625.383000</b>
Model Code	300
Rated Softening Capacity (Grains @ Salt Dose)	8,300 @ 1.7 lbs. 20,400 @ 6.5 lbs. 24,400 @ 11.0 lbs.
Rated Efficiency (Grains/Pound of Salt @ Minimum Salt Dose)	4,880 @ 1.7 lbs.
Rated Service Flow Rate	7.3 gpm
Amount of High Capacity Ion Exchange Resin	0.68 cu. ft.
Pressure Drop at Rated Service Flow	15 psig
Water Supply Max. Hardness	70 gpg
Water Supply Max. Clear Water Iron	5 ppm*
Water Pressure Limits (minimum / maximum)	20 - 125 psi
Water Temperature Limits (minimum / maximum)	40 - 120 °F
Minimum Water Supply Flow Rate	3 gpm
Maximum Drain Flow Rate	0.9 gpm

\*Capacity to reduce clear water iron is substantiated by WQA test data. State of Wisconsin requires additional treatment if water supply contains clear water iron exceeding 5 ppm.

These systems conform to NSF/ANSI 44 for the specific performance claims as verified and substantiated by test data.

The efficiency rating is only valid at the stated salt dose. These softeners were efficiency rated according to NSF/ANSI Standard 44.

**Variable Salt Dose:** The salt dose is selected by the electronic controls at regeneration time based on the amount needed.

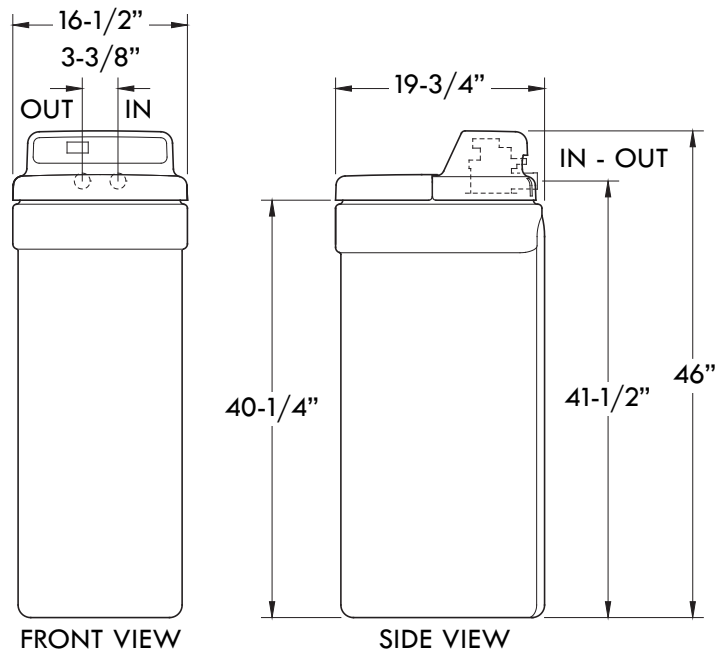

Figure 1

# Packing List

The parts required to assemble and install the water softener are included with the unit. Thoroughly check the water softener for possible shipping damage and parts loss. Also inspect and note any damage to the shipping carton.

Remove and discard (or recycle) all packing materials. To avoid loss of small parts, we suggest you keep the small parts in the parts bag until you are ready to use them.

## Small Parts

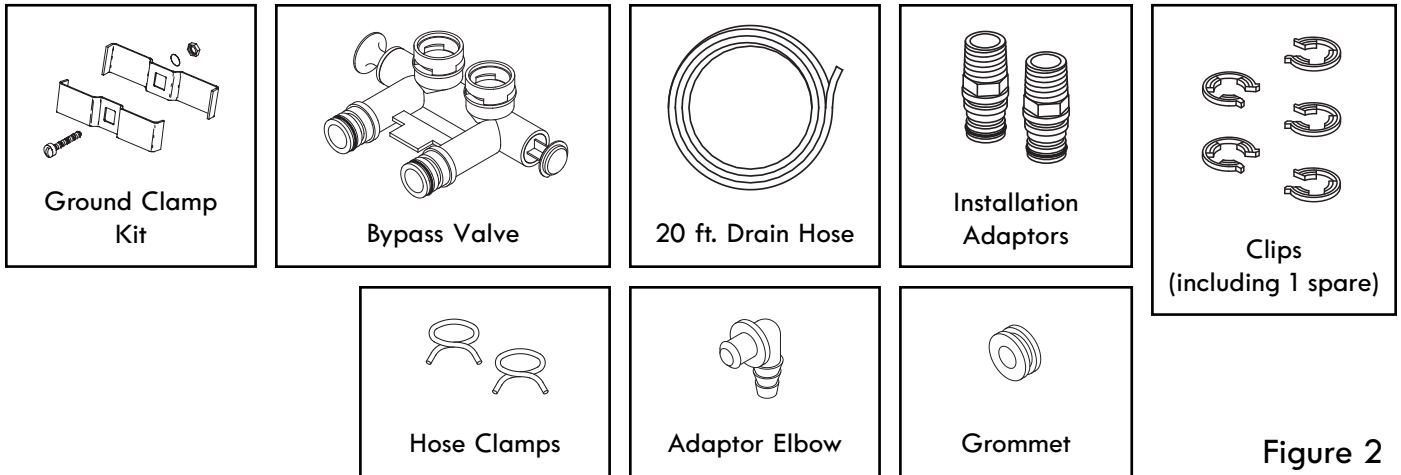
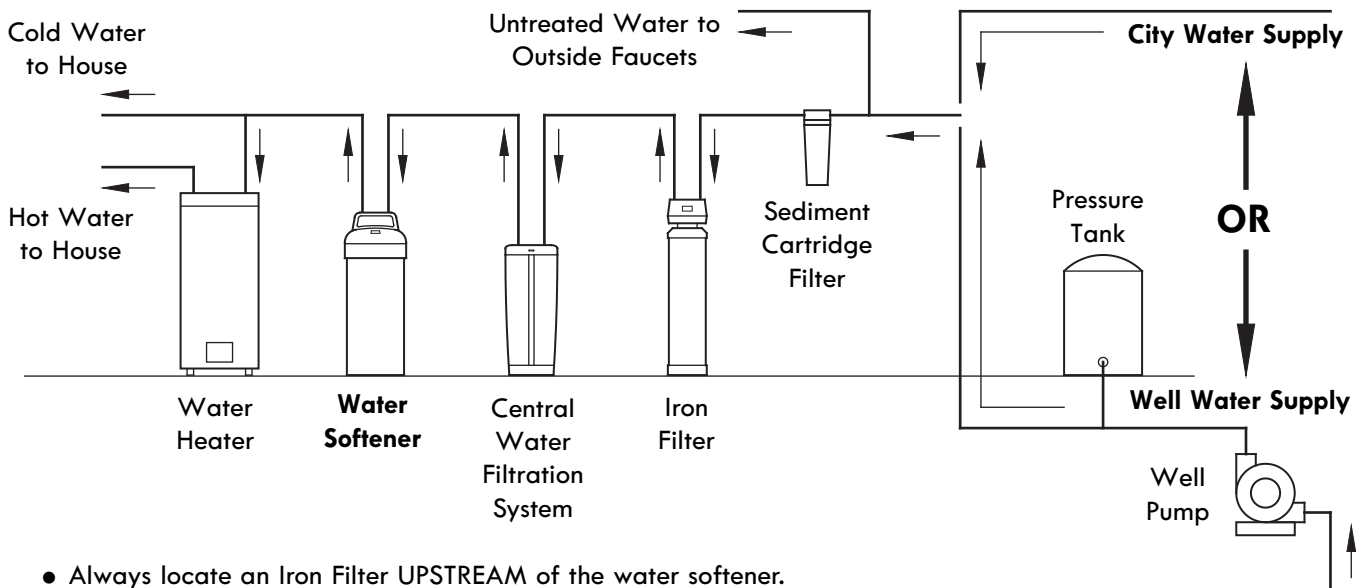

Figure 2

# Plan Your Installation

## THE PROPER ORDER TO INSTALL WATER TREATMENT EQUIPMENT

(Shows sequence of equipment only - not all items are needed in all applications)



- Always locate an Iron Filter UPSTREAM of the water softener.
- Locate a Central Water Filtration System UPSTREAM of the water softener on a chlorinated water supply, or DOWNSTREAM of the water softener on a non-chlorinated water supply.

Figure 3

Questions? Call the Kenmore Water Line 1-800-426-9345 or visit [www.kenmorewater.com](http://www.kenmorewater.com)

# Plan Your Installation

## TYPICAL INSTALLATION

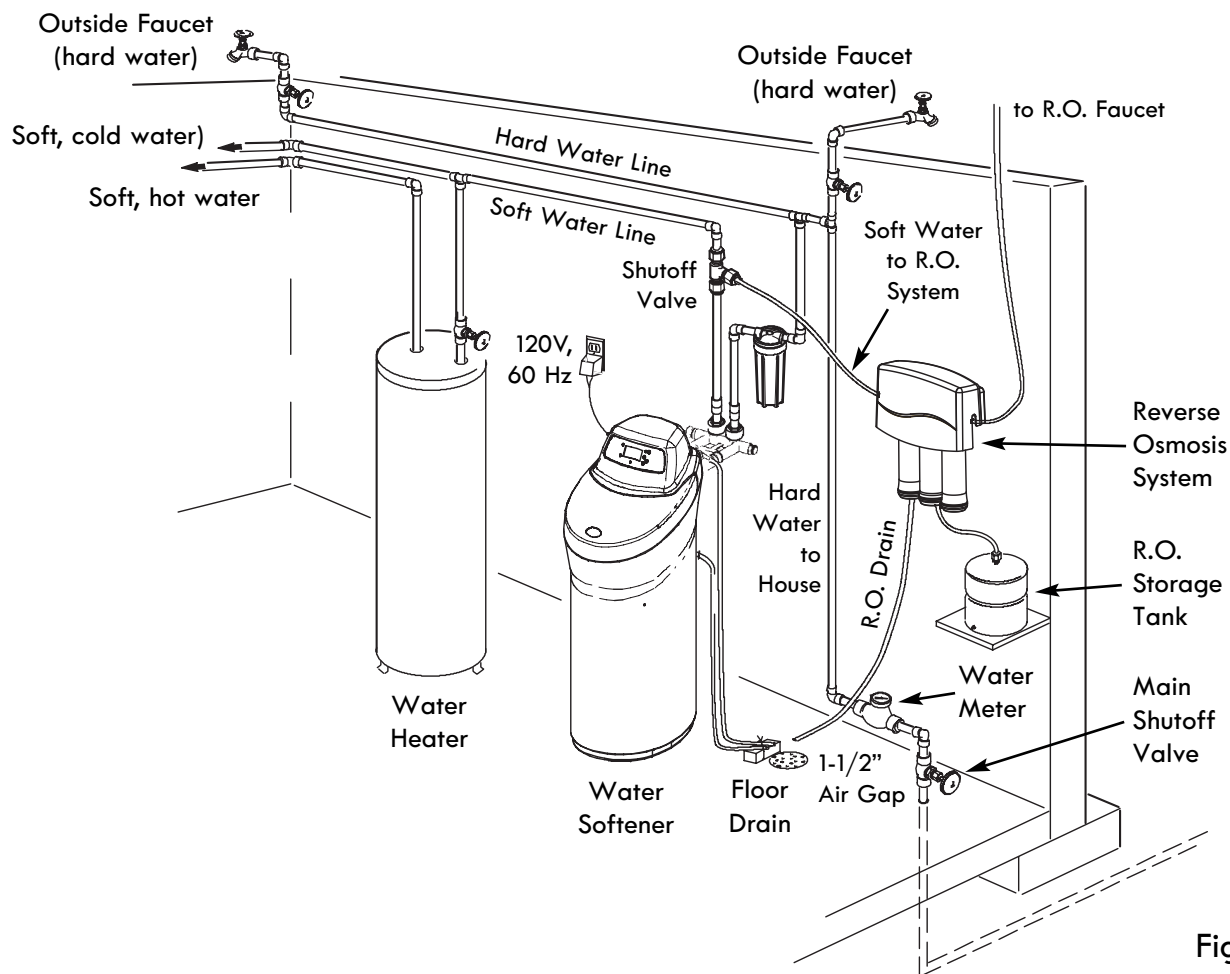

Figure 4

### WHERE TO INSTALL THE WATER SOFTENER

Review the following points before you choose a place to put your softener:

1. Place as close as possible to, but always downstream from, the pressure tank (well water) or water meter (city water).
2. Place as close as possible to a water drain such as a floor drain, laundry tub, sump or standpipe (See Fig. 4).
3. Connect to the house main water pipe **UPSTREAM OF THE WATER HEATER** (See Fig. 3). The temperature of water going through the softener must not be more than 120°F (49°C). Hot water will damage inner softener parts. To reduce the risk of hot water backup, piping between the softener and water heater should be as long as possible.
4. Keep outside faucets on hard water to save soft water and salt. See Fig. 4.
5. Do not install in a place where the softener could freeze. Damage caused by freezing voids the warranty by Sears Brands Management Corporation.
6. Put the softener in a place where water damage is least likely to occur if it develops a leak. Sears or the manufacturer will not repair or pay for water damage.
7. A grounded, 120V, 60 Hz. electrical outlet is needed within 10 feet of the softener to plug in the transformer (See Fig. 4). Be sure the outlet and transformer are in an inside location, protected from wet weather. Use a continuously "live" outlet, which cannot be accidentally switched off.
8. When installing in an outside location, you must take the steps necessary to assure the softener, installation plumbing, and wiring, are protected from the elements, direct sunlight, contamination, vandalism, etc.

Questions? Call the Kenmore Water Line 1-800-426-9345 or visit [www.kenmorewater.com](http://www.kenmorewater.com)

# Plan Your Installation

## CHECK YOUR WATER PRESSURE BEFORE INSTALLING

For your water softener to work properly, incoming water pressure in your house pipes must be no lower than 20 pounds per square inch (psi). The highest allowable pressure is 125 psi. If pressure is above 125

psi, buy and install a pressure reducing valve in the pipe supplying water to the softener's inlet.

**NOTE:** If water pressure during the day is 100 psi or more, pressure during the night may go above 125 psi.

# Installation

## INSTALL SINGLE BYPASS VALVE AND/OR THREADED INSTALLATION ADAPTORS

Complete the following steps to assemble the adaptors and/or the included single bypass valve.

1. Close the shutoff valve on the house main water pipe, near the water meter or pressure tank, to turn off the water.
2. Shut off the gas or electric supply to the water heater.
3. Open the highest and lowest water faucets in your house. This will let water drain from the pipes. Close faucets after water has drained.
4. Remove the top cover. Remove the salt lid first and then pull outward on the two tabs to release top cover (see Fig. 5). Set both covers aside so they will not get scratched or broken.

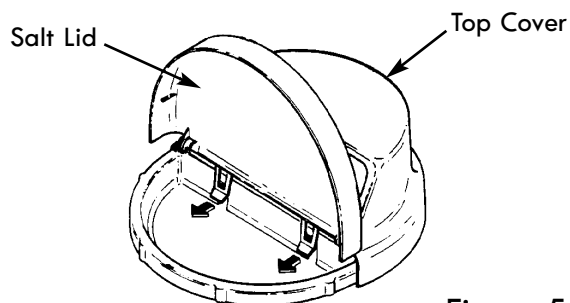

Figure 5

5. Visually check and remove any foreign materials from the valve inlet and outlet ports (see Fig. 6). Carefully remove the two large plastic clips (you will use them). Check to be sure the turbine and support are firmly in place (see Fig. 7).

**NOTE:** If you will not install the included bypass valve because you will have a 3-valve bypass in your plumbing, skip step 6, but perform step 7.

### SINGLE BYPASS VALVE:

6. Push the bypass valve into the softener valve's inlet and outlet ports as far as it will go. Snap the two large holding clips into place, from the top down as shown (see Fig. 8).

**CAUTION:** Be sure the clips snap firmly into place so the bypass valve will not pull out.

### INLET AND OUTLET THREADED ADAPTORS:

7. Push the adaptors into the valve inlet and outlet ports, or bypass valve ports, as far as they will go. Both adaptors are the same and fit either port. Snap the two large holding clips into place, as shown (see Fig. 8).

**CAUTION:** Be sure the clips snap firmly into place so the adaptors will not pull out.

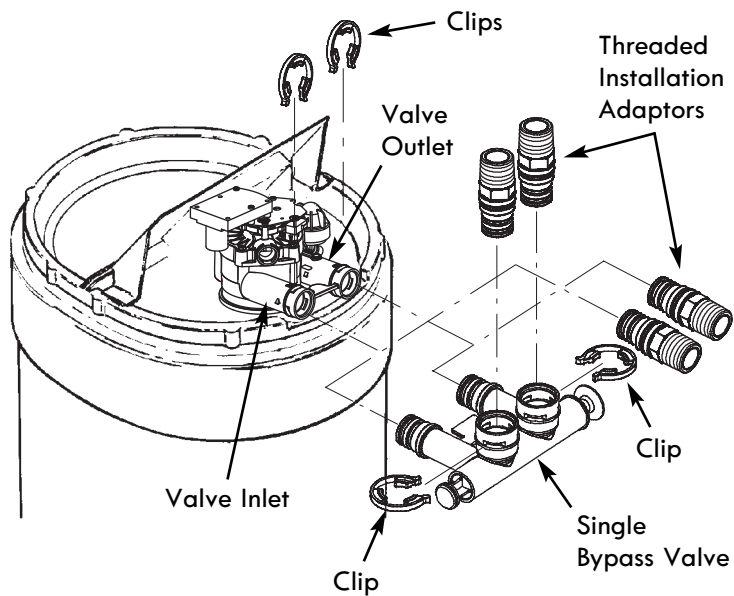

Figure 6

# Installation

## INSTALL SINGLE BYPASS VALVE (cont.)

Before installing the bypass valve and/or installation adaptors, make sure that the turbine and support are firmly in place inside the softener valve's outlet port.

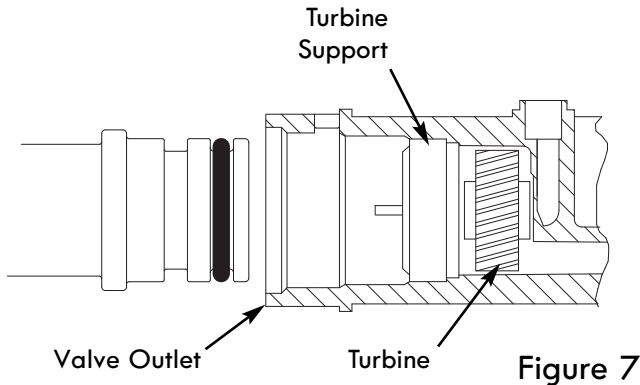

Figure 7

## INSTALL HOLDING CLIPS

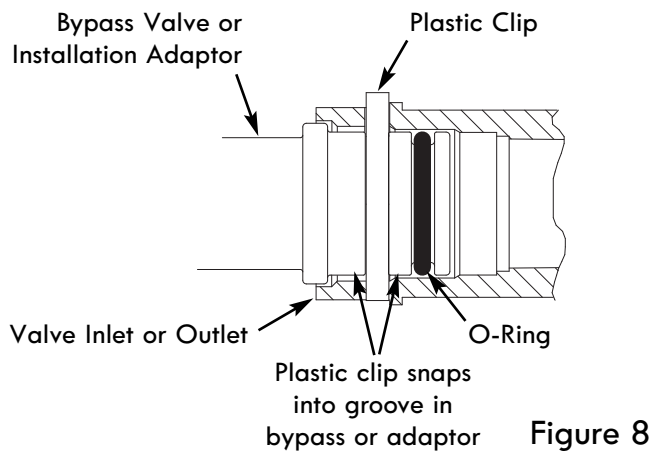
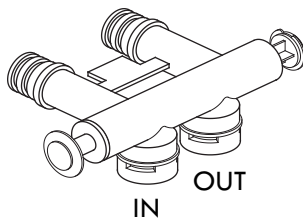

Figure 8

## ALTERNATE BYPASS VALVE INSTALLATION



If connecting to floor level plumbing, install the bypass valve turned downward, as shown.

Figure 9

## ASSEMBLE INLET AND OUTLET PLUMBING

Measure, cut (thread if needed) and put together all pipe and fittings up to the main water pipe. Make sure that the incoming water supply pipe goes to the valve inlet side.

**CAUTION:** Never solder fittings while connected to nonmetallic parts. Wait until soldered pipe has cooled before connection. See Fig. 10.

**CAUTION:** Be careful when putting pipe fittings together. Do not cross thread, and do not over-tighten.

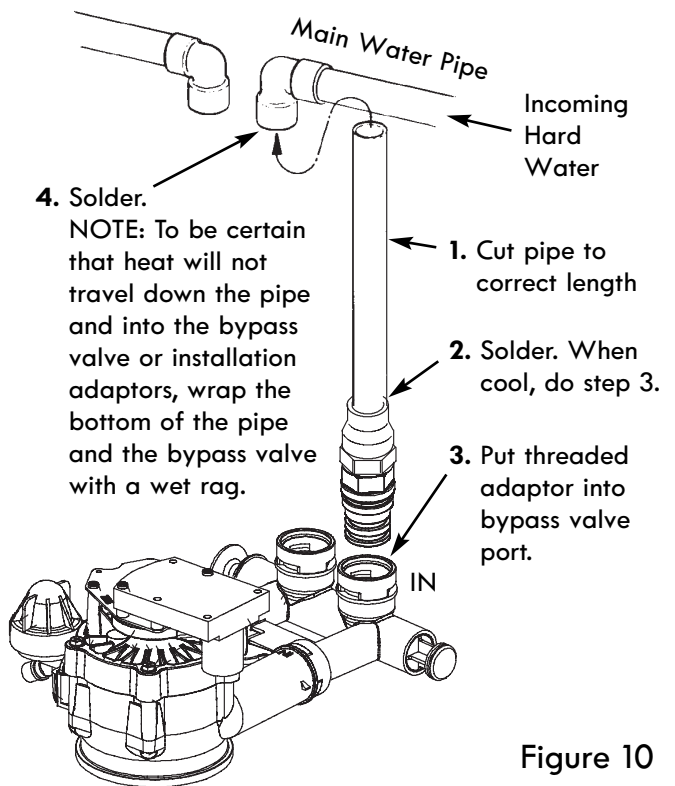

Figure 10



# Installation

## CONNECT THE VALVE DRAIN HOSE

Take a length of 3/8" inside diameter drain tubing (supplied) and attach one end to the drain fitting (see Fig. 11). Use a tube clamp from the parts bag to hold it in place. Put the other end of the tubing over a floor drain, into a laundry tub, standpipe, or other suitable drain. Check your local codes.

Leave an air gap of about 1-1/2" between the end of the hose and the drain. This gap is needed so you don't get a backflow of sewer water into the softener. Do not put the end of the hose into the drain or connect without the air gap.

Locate and support the hose so it does not kink or have sharp bends. Secure the hose end so water pressure does not cause the hose to "whip". Tie or wire it in place. Do not pinch the hose shut. The softener will not work if this drain hose is pinched, plugged, closed or restricted in any way. Direct drain flow down into drain from drain line as flow could possibly overshoot the drain cover.

Keep the hose lower than the drain fitting. In some homes, to get to a drain you must raise the hose and run it overhead. Do not raise the hose more than 8 feet above the floor.

**COPPER DRAIN TUBE:** Local plumbing codes may require the use a copper valve drain tube. A copper tube is also best to use if running a drain line overhead.

To adapt a copper drain tube to the softener, purchase a compression fitting (1/4" female pipe threads x 1/2" O.D. tube) and tubing from your local hardware store.

## CONNECT SALT TANK OVERFLOW HOSE

1. Locate the rubber grommet, adaptor elbow and tube clamp (see Fig. 11) that are in the parts bag.
2. Push the grommet into the hole in the salt tank wall so that half is inside and half is outside.
3. Push the larger end of the adaptor into the grommet.
4. Push one end of a length of 3/8" I.D. tubing (supplied) onto the tube adaptor, using a tube clamp from the parts bag to hold it in place.
5. Put the other end of the tubing over the floor drain.

**IMPORTANT:** Overflow water must run down by gravity through the tubing. Do not raise the tubing higher than the adaptor (see Fig. 11).

**IMPORTANT:** Do not connect this hose to the valve drain hose you just installed (see above). Both drains must have a separate hose.

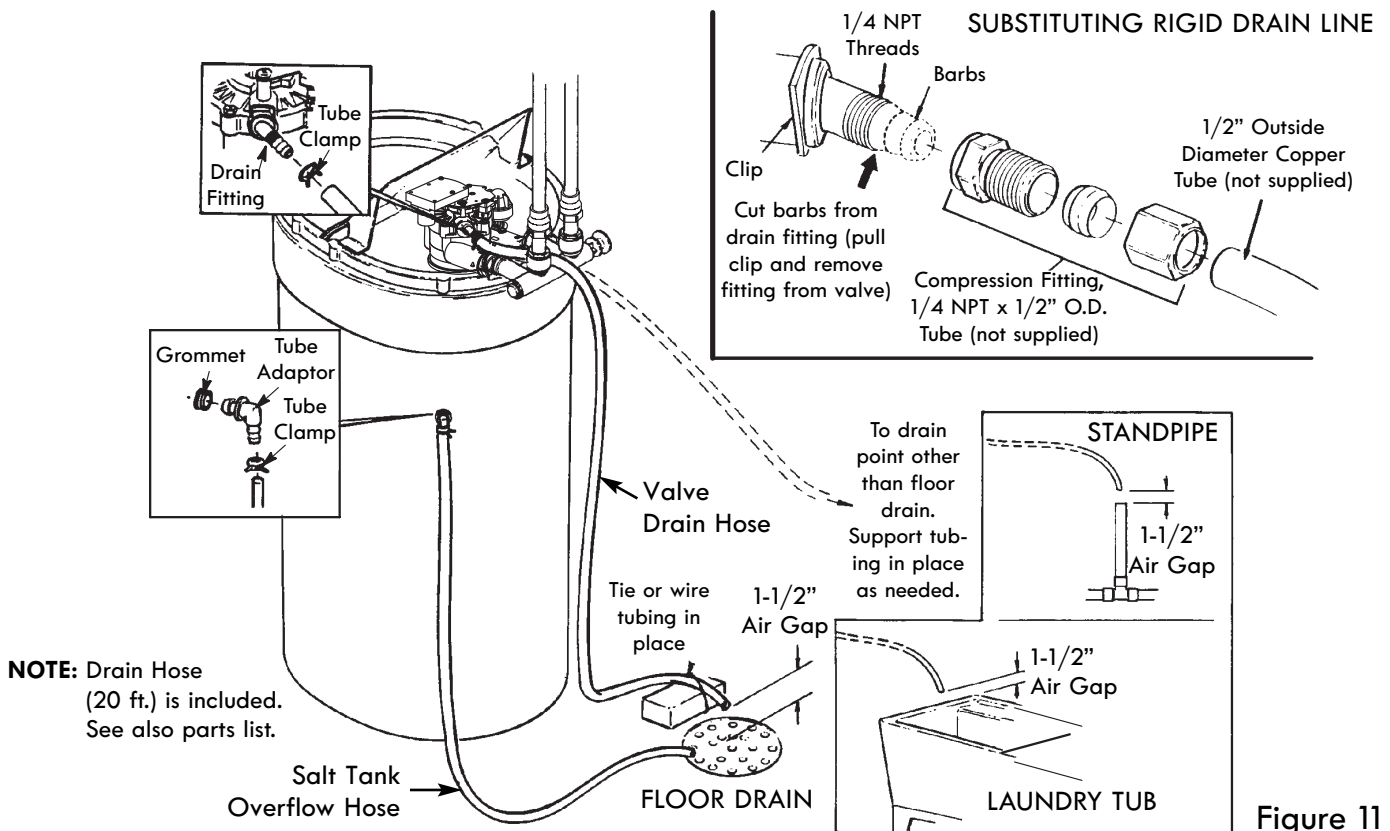

# Installation

## LEAK TEST

To check for leaks, complete the following steps:

**CAUTION:** To avoid water or air pressure damage to softener inner parts, and to flush pipe chips or other residue from the water pipes, be sure to do the following steps exactly as instructed.

1. Fully open two nearby cold water faucets downstream from the softener.
2. Place bypass valve(s) in "bypass" position (see Figures 12 & 13). On a single valve, slide the stem inward to bypass. On a 3-valve bypass, close the inlet and outlet valves and open the bypass valve.
3. Fully open the house main water pipe shutoff valve. Observe steady water flow from both open faucets.
4. Place bypass valve(s) in SERVICE, EXACTLY as follows: Keep soft water faucets open.
  - a. Single Bypass Valve: Slowly, slide pull the valve stem outward toward service, pausing several times to allow the softener to pressurize gradually.
  - b. 3-Valve Bypass: Fully close the bypass valve and open the outlet valve. Slowly open the inlet valve, pausing several times to allow the softener to pressurize gradually.
5. After about three minutes, open a hot water faucet for about one minute, or until all air is expelled, then close.
6. Close both cold water faucets.
7. Check your plumbing work for leaks, and fix right away if any are found. Be sure to observe previous caution notes.

**NOTE:** If this procedure is performed on a new softener, water coming from the taps may initially be discolored. This normally occurs the first time water runs through the resin bed. The discolored water is not harmful, and the discoloration will not last more than a few minutes.

## SINGLE BYPASS VALVE

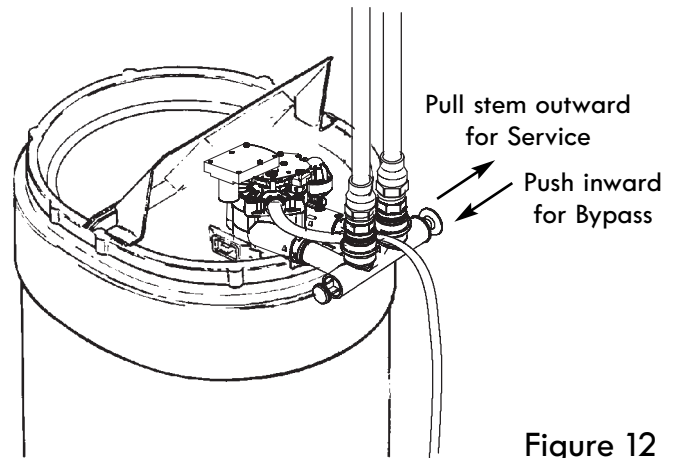

Figure 12

## 3-VALVE BYPASS

**FOR SERVICE**  
Close bypass valve.  
Open inlet & outlet valves.

**FOR BYPASS**  
Open bypass valve.  
Close inlet & outlet valves.

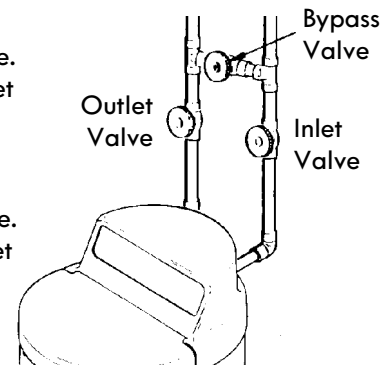

Figure 13

# Installation

## INSTALL GROUNDING CLAMP

The house cold water pipe (iron or copper) is often used to ground all electrical outlets in the home. To maintain this ground, use the ground clamp kit included in the parts bag. Install the ground clamp across the inlet and outlet metal pipes (see Fig. 14). Make sure good contact is made between the pipe and the clamps.

## INSTALL COVERS

After installing your water softener, put the covers on. Angle the covers so the top cover clips onto the back first, then bring down in front and clip on the tabs inside the rim and lower the salt lid closed (See Fig. 5).

## CONNECT TO ELECTRICAL POWER

The softener works on 24 volt, 60 Hz electrical power. The included transformer changes standard 120 volt AC house power to 24 volts. You must plug the water softener's transformer into a grounded, 120 volt outlet only. Be sure the outlet is always "live" so it cannot be switched off by mistake.

**NOTE:** The electrical outlet you plug the transformer into must be indoors, protected from weather.

## RESTART THE WATER HEATER

Turn on the gas (or electric) supply to the water heater and light the pilot.

**YOUR PLUMBING INSTALLATION AND ELECTRICAL WORK ARE NOW COMPLETE.**

## METAL PIPE GROUNDING

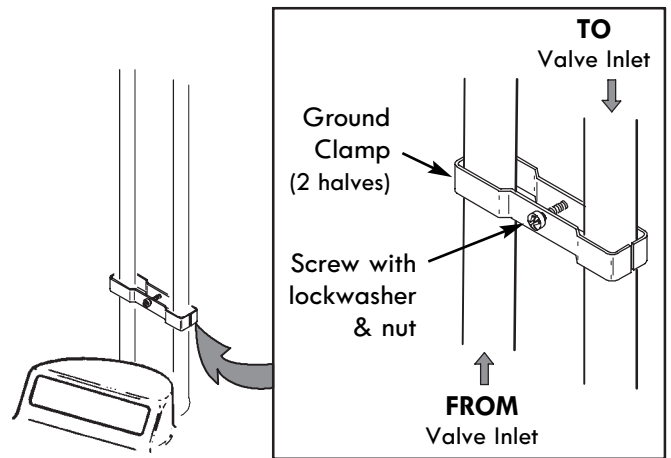

Figure 14

# Programming the Softener

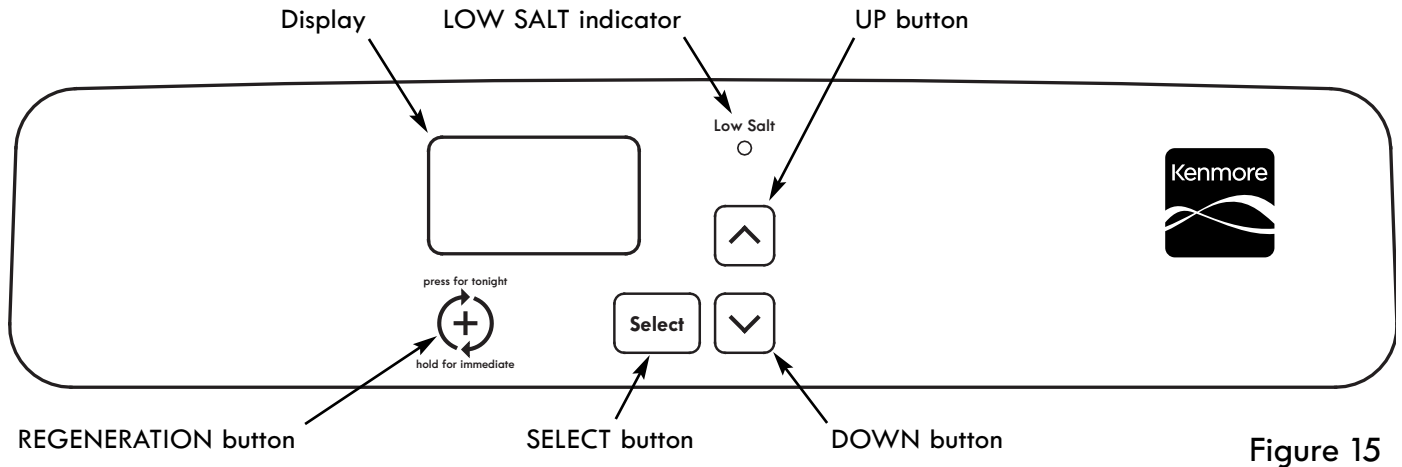

Figure 15

## PROGRAM THE SOFTENER

When the transformer is plugged into the electrical outlet, the model code (300) and a test number (example: J3.0, are briefly shown in the display. Then the words "SET TIME" appear and 12:00 PM begins to flash.

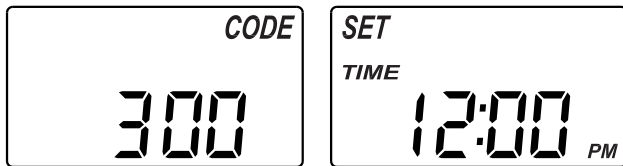

Figure 16

## SET PRESENT TIME OF DAY

If the words "SET TIME" do not show in the display, press the SELECT button a few times until they do.

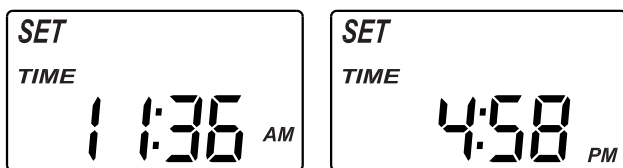

Figure 17

1. Press the  $\triangle$  UP or  $\nabla$  DOWN buttons to set the present time. Up moves the display ahead; down sets the time back. Be sure AM or PM is correct.

**NOTE:** Press buttons and quickly release to slowly advance the display. Hold the buttons down for fast advance.

2. When the correct time is displayed, press the SELECT button, and the display will change to show the "Hardness" screen.

## SET WATER HARDNESS NUMBER

If you completed the previous step, the words "SET HARDNESS" should show in the display. Otherwise, press the SELECT button several times until they do.



Figure 18

1. Press the  $\triangle$  UP or  $\nabla$  DOWN buttons to set the hardness of your water supply, in grains per gallon. The default is 25.

**NOTE:** If your water supply contains iron, compensate for it by adding to the water hardness number. For example, assume your water is 20 gpg hard and contains 2 ppm iron. Add 5 to the hardness number for each 1 ppm of iron. In this example, you would use 30 for your hardness number.

$$\begin{array}{r}
 20 \text{ gpg hardness} \\
 2 \text{ ppm iron} \times 5 = 10 \quad +10 \\
 \text{(times)} \qquad \qquad \qquad 30 \text{ HARDNESS NUMBER}
 \end{array}$$

If your water supply contains iron, it is recommended that you clean your water softener resin bed at least every 6 months. Your local Sears store has Water Softener Cleaner (Part Number 34427) available.

2. When finished setting your water's hardness number, press the SELECT button, and the display will change to show the "Set Recharge Time" screen.

# Programming the Softener

## SET RECHARGE (REGENERATION) START TIME

If you completed the previous step, the words "SET RECHARGE TIME" should show in the display. Otherwise, press the SELECT button several times until they do.

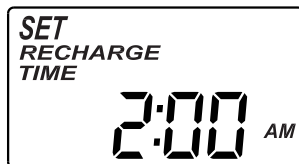

Figure 19

1. The softener's default recharge start time is 2:00 AM. This is normally a time of day when water is not being used in the household. Hard water bypasses the softener if the household draws water during the recharge cycle. If a different recharge start time is desired, press the  $\triangle$  UP or  $\nabla$  DOWN buttons to change the time, in 1-hour increments. Be sure AM or PM is correct.
2. When the desired recharge start time is displayed, press the SELECT button, and the display will change to show the "Set Salt Level" screen.

## SET SALT LEVEL

The water softener has a salt monitor indicator light to remind you to add salt to the storage tank.

**NOTE: You must set salt level each time salt is added to the water softener.**

**NOTE:** The salt monitor system estimates salt levels, and accuracy will vary with different salts.

**To set this monitor system:**

If you completed the previous step, the words "SET SALT LEVEL" should show in the display. Otherwise, press the SELECT button several times until they do.

1. Lift the salt lid and level the salt in the storage tank.
2. The yellow salt level decal, on the brinewell inside the tank, has numbers from 0 to 8 (see Fig. 20). Observe the highest number the leveled salt is at, or closest to.

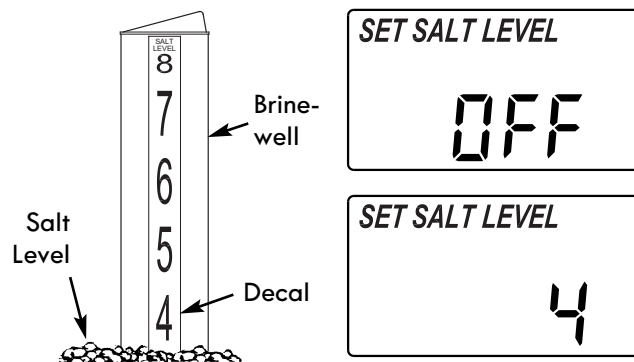

Figure 20

3. Press the  $\triangle$  UP or  $\nabla$  DOWN buttons to set the salt level to match to the number on the decal. At level 2 or below, the "Low Salt" indicator will flash. If you want to turn the salt monitor off, press the  $\nabla$  DOWN button past 0, until "SALT LEVEL OFF" shows in the display.
4. When the correct salt level is displayed, press the SELECT button, and the display will return to the normal run (time of day) screen.

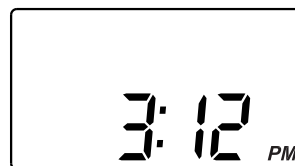

Figure 21

# Sanitizing the Softener

## SANITIZE THE WATER SOFTENER

1. Open salt lid, remove the brinewell cover and pour about 3 oz. (6 tablespoons) of household bleach into the softener brinewell. Replace the brinewell cover.
2. Make sure the bypass valve(s) is in the "service" (open) position.
3. **Start a recharge:** Press the REGENERATION button and hold for 3 seconds, until "RECHARGE NOW" begins to flash in the display. This recharge draws the sanitizing bleach into and through the water softener. Any air remaining in the unit is purged to the drain.
4. After the recharge has completed, fully open a cold water faucet, downstream from the softener, and

allow 50 gallons of water to pass through the system. This should take at least 20 minutes. Close the faucet.

Your new Sears softener is now softening the water for your household needs. However, your **WATER HEATER is filled with hard water**. To have fully soft water right away, you can drain the water heater so it refills with soft water. If you don't drain the water heater, it will take a few days before you have fully soft water.

**NOTE:** If this procedure is performed on a new softener, water coming from the taps may initially be discolored. This normally occurs the first time water runs through the resin bed. The discolored water is not harmful, and the discoloration will not last more than a few minutes.

# Adding Salt to the Storage Tank

## ADDING SALT TO THE STORAGE TANK

You must keep salt in the tank, but it is not necessary to fill it full. Especially in humid areas, it is best to fill the storage tank no more than half full, and to add salt more often. Salt "bridging" occurs more often when conditions are humid.

Use NUGGET or PELLET water softener salt. **DO NOT** use rock salts, as they have dirt and sediments that will stop the softener from working. To maintain optimum performance of your water softener, the salt tank should be cleaned out every 2 to 3 years.

## POTASSIUM CHLORIDE (KCl) SALT

If you choose Potassium Chloride (KCl) as a regenerant, following these suggestions will help give you years of maintenance free service.

1. Place only one bag of KCl in your softener at a time (the salt storage tank should contain no more than 60 pounds of KCl at any one time).
2. A softener using KCl should not be placed in areas with temperature fluctuations and high humidity (KCl will harden in these environments and may make the softener inoperable).
3. Check the brine tank and brinewell (black tube in salt storage tank) monthly. If hardening is present, pour small amounts of warm water onto hardened areas until they loosen.
4. If your softener does not have a KCl salt setting, you must increase your hardness setting by 25% to ensure continuous soft water. See table at right.

Untreated Water Hardness (grains per gallon)	Softener Setting when using KCl salt (add 25%)
5 gpg	7 gpg
10 gpg	13 gpg
15 gpg	19 gpg
20 gpg	25 gpg
25 gpg	35 gpg
30 gpg	40 gpg
35 gpg	45 gpg
40 gpg	50 gpg

Persons who are on sodium restricted diets should consider the added sodium as part of their overall sodium intake. For example, if your water supply is 15 grains hard, and you drank 3 quarts of softened water you would consume 335 milligrams of sodium. That is equivalent to eating 2-1/2 slices of white bread.

## WATER SOFTENING SALT WITH IRON REMOVING ADDITIVES

Some salts have an additive to help the softener handle iron in the water supply. These salts may be used if your water supply has a high iron content. It is recommended to use Sears Water Softener Cleaner (refer to the parts list in back of manual for part number) for periodic treatments to keep your resin bed clean. This is available at your local Sears store.

Persons who are concerned about their drinking water should consider a Kenmore reverse osmosis drinking water system that will remove in excess of 90% of the sodium and other drinking water contaminants.

Questions? Call the Kenmore Water Line 1-800-426-9345 or visit [www.kenmorewater.com](http://www.kenmorewater.com)

# Controller Features

## EXTRA RECHARGE

Sometimes, a manually initiated recharge (regeneration) may be desired, or needed. Two examples are:

- You have used more water than usual (guests visiting) and you may run out of soft water before the next automatic regeneration.
- You did not add salt to the softener before it ran out. Add salt to the softener before regenerating.

You can start a regeneration immediately, or you can set the controller to regenerate at the next preset recharge time (2:00 AM, or as set).

## RECHARGE NOW

Press the REGENERATION button and hold for 3 seconds, until the words "RECHARGE NOW" begin to flash in the display. The softener enters the fill cycle of regeneration immediately. This regeneration will take about 2 hours to complete. Then, you will have soft water again.

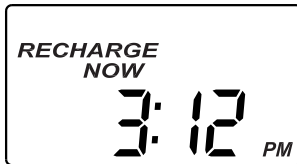

Figure 22

## RECHARGE TONIGHT

Press and release (do not hold) the REGENERATION button. "RECHARGE TONIGHT" will begin flashing in the display, and the softener will begin regeneration at the next preset recharge time (2:00 AM, or as set). If you decide to cancel the regeneration before it starts, press and release the REGENERATION button once more. "RECHARGE TONIGHT" will stop flashing in the display.



Figure 23

## SALT MONITOR SYSTEM

The water softener has a salt monitor indicator light to remind you to add salt to the storage tank.

**NOTE: You must set salt level each time salt is added to the water softener.**

**NOTE:** The salt monitor system estimates salt levels, and accuracy will vary with different salts.

**To set this monitor system:**

1. Lift the salt lid and level the salt in the storage tank.
2. The yellow salt level decal, on the brinewell inside the tank, has numbers from 0 to 8 (see Fig. 24). Observe the highest number the leveled salt is at, or closest to.
3. Press the SELECT button once, and the words "SET SALT LEVEL" should show in the display.

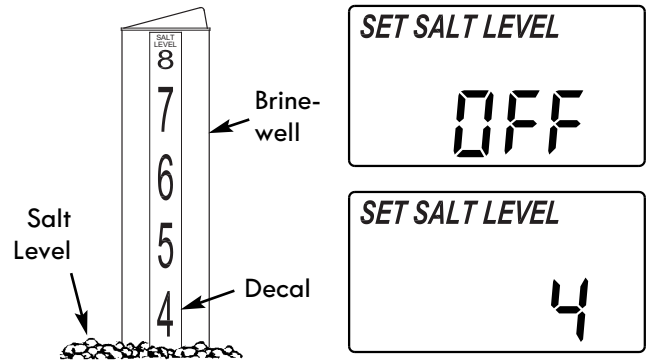

Figure 24

4. Press the  $\Delta$  UP or  $\nabla$  DOWN buttons to set the salt level to match the number on the decal. At level 2 or below, the "Low Salt" indicator will flash. If you want to turn the salt monitor off, press the  $\nabla$  DOWN button past 0, until "SALT LEVEL OFF" shows in the display.
5. When the correct salt level is displayed, press the SELECT button, and the display will return to the normal run (time of day) screen.

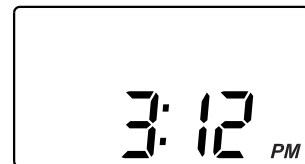

Figure 25

# Controller Features

## EFFICIENCY MODE

When this feature is ON, the water softener will operate at salt efficiencies of 4000 grains of hardness per pound of salt or higher. The softener may recharge more often using smaller salt dosage and less water. This softener is shipped with the efficiency feature set OFF. **Installations in the state of California require this setting to be turned ON.**

To turn this feature ON:

1. Press and hold the SELECT button until the display shows "000 - -".



Figure 26

2. Then press (do not hold) the SELECT button again. Use the  $\triangle$  UP button to turn "ON".

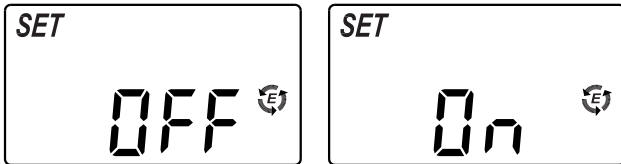

Figure 27

3. Press SELECT several times to return to the normal run (time of day) screen. The efficiency icon will only be displayed when this feature is ON.



Figure 28

### California Efficiency Requirement

Your Kenmore Water Softener has a "High Efficiency" feature that can be set ON or OFF. This softener is shipped with the efficiency feature set OFF, which will utilize the maximum rated capacity while most often achieving maximum salt efficiencies. When installing this unit in the State of California, you **MUST** turn the efficiency feature ON. The softener may initiate more frequent recharges, but it will operate at 4000 grains per pound of salt or higher.

## BACKWASH & FAST RINSE TIMES

If you experience salty tasting water after regeneration, you may need to increase the backwash and fast rinse times. The cycle times during regenerations are determined by the softener's electronic controller. However, you may increase the backwash and fast rinse times, in 1 minute increments, as follows:

1. Press and hold the SELECT button until the display shows "000 - -" (see Fig. 26).
2. Then press (do not hold) the SELECT button twice to display the alternating screens shown in Figure 29.

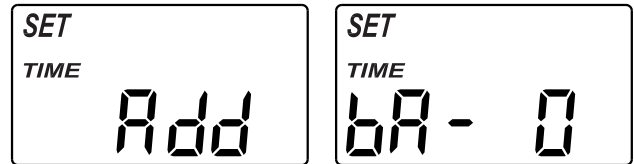

Figure 29

3. Use the  $\triangle$  UP button to add up to 15 minutes to the backwash time.
4. Press SELECT to display the alternating screens shown in Figure 30.

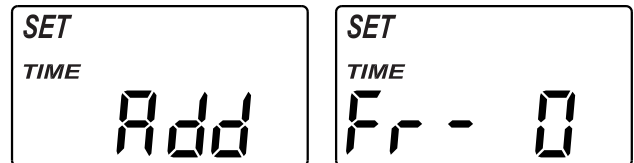

Figure 30

5. Use the  $\triangle$  UP button to add up to 15 minutes to the fast rinse time.
6. Press SELECT to return to the normal run (time of day) screen.

## PROGRAM MEMORY

If electrical power to the softener goes off, the time display is blank but the electronic controller keeps the correct time for several hours. When electrical power comes on again, you will have to reset the present time only if the display is flashing. The **HARDNESS**, **RECHARGE TIME** and **SALT LEVEL** never require resetting unless a change is desired. Even if the clock is incorrect after a long power outage, the softener works as it should to keep your water soft, however, regenerations may occur at the wrong time of day until you reset the clock to the correct time of day.



# Care of Your Water Softener

## SALT BRIDGE

Sometimes, a hard crust or salt “bridge” forms in the brine tank. It is usually caused by high humidity or the wrong kind of salt. When the salt “bridges,” an empty space forms between the water and the salt. Then, salt will not dissolve in the water to make brine. Without brine, the resin bed is not recharged and hard water will result.

If the storage tank is full of salt, it is difficult to tell if you have a salt bridge. A bridge may be underneath loose salt. Take a broom handle, or like tool, and hold it next to the water softener. Measure the distance from the floor to the rim of the water softener. Then, gently push the broom handle straight down into the salt. If a hard object is felt before the pencil mark is even with the top, it is most likely a salt bridge. Gently push into the bridge in several places to break it. Do not use any sharp or pointed objects as you may puncture the brine tank. Do not try to break the salt bridge by pounding on the outside of the salt tank. You may damage the tank.

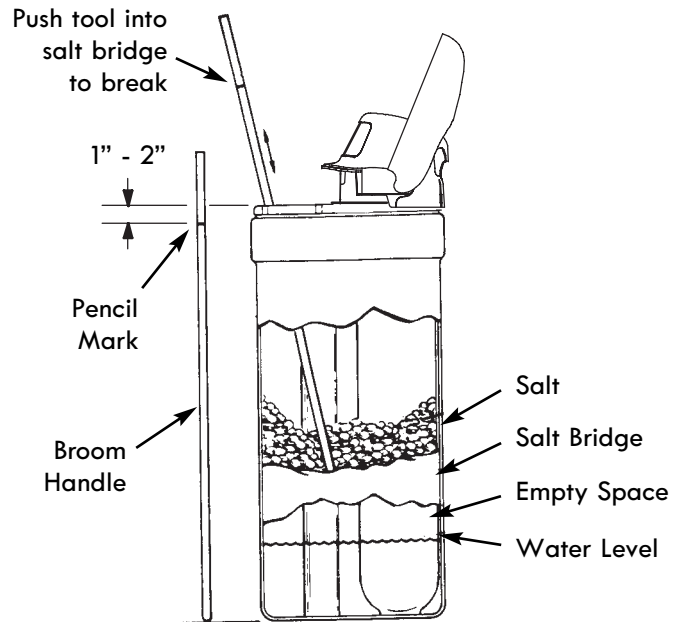

Figure 31

## Service Information

### ALWAYS MAKE THESE INITIAL CHECKS FIRST

1. Does the time display show the correct time of day?
  - If display is blank, check power source to the softener.
  - If time is flashing, power was off for a long period. The softener resumes normal operation but regenerations occur at the wrong time.
  - If an error code (example: "Err03") shows in the display, go to "Troubleshooting".
2. Are bypass valve(s) fully in service position?
3. Are the inlet and outlet pipes connected to the softener inlet and outlet respectively?
4. Is the softener's transformer plugged into a "live", grounded wall outlet, and the power cable fastened securely to the controller?
5. Is the valve drain hose free of kinks and sharp bends, and not elevated more than 8 ft. above the floor?
6. Is there salt in the storage tank?
7. Is the brine tubing connected? Brine tubing connects to nozzle/venturi and brine valve assembly.
8. Press the SELECT button three times to display the hardness setting. Make sure it is correct for the household's water supply. Perform a hardness test of the untreated incoming water and compare with the hardness setting. Also test a soft water sample to verify if a problem exists. Press the SELECT button twice more to return to present time display.

# Service Information

## TROUBLESHOOTING

If your water softener does not work properly, make the following easy checks. Often, you will find what is wrong yourself and you won't have to call and wait for service. If you do not find anything wrong while making the checks, and your softener still does not work properly, call your Sears Service Department.

PROBLEM	CAUSE	CORRECTION
<b>No soft water</b>	No salt in the storage tank.	Add salt and then use RECHARGE NOW feature.
<b>No soft water &amp; display is blank</b>	Transformer unplugged at wall outlet, or power cable disconnected from back of electronic board or transformer malfunction.	Check for loss of power and correct. Reprogram electronic control and then use RECHARGE NOW feature.
	Fuse blown, circuit breaker tripped, or circuit switched off (see "Power Outage Memory").	Replace fuse, reset circuit breaker, or switch circuit on, and then use RECHARGE NOW feature.
<b>No soft water &amp; salt level not dropping</b>	Salt storage tank "bridged".	Refer to "Breaking a Salt Bridge".
	Bypass valve(s) in "bypass" position.	Move bypass valve(s) to "service" position.
<b>No soft water &amp; salt storage tank full of water</b>	Dirty, plugged or damaged nozzle & venturi assembly	Take apart, clean and inspect nozzle & venturi (see instruction decal under salt lid).
	Valve drain hose is plugged or restricted.	Hose must not have any kinks, sharp bends or any water flow blockage (See "Valve Drain Requirements").
<b>Intermittent hard water</b>	Incorrect time set.	Check and change time setting.
	Incorrect water hardness set.	Refer to "Set Water Hardness Number" to set correctly.
	Hot water being used when softener is regenerating.	Avoid using hot water while the softener is regenerating, as the water heater will fill with hard water.
	Possible increase in water hardness.	Test untreated water for hardness and iron. Program the water softener accordingly (see "Set Water Hardness Number").
<b>Brine tank flooded</b>	Valve drain hose is plugged or restricted.	Hose must not have any kinks, sharp bends or any water flow blockage (See "Valve Drain Requirements").
	Dirty, plugged or damaged nozzle & venturi assembly.	Take apart, clean and inspect nozzle & venturi (see "Cleaning the Nozzle & Venturi").
<b>Salty tasting water immediately after regeneration</b>	Backwash and fast rinse cycle times are not long enough.	Increase backwash & fast rinse times (see "Back Wash & Fast Rinse Times").
	Valve drain hose is plugged or restricted.	Hose must not have any kinks, sharp bends or any water flow blockage (see "Valve Drain Requirements").
<b>Error code appears (example: "Err03")</b>	Fault in electronic controller or wiring harness connections to position switch, position switch inoperable or motor inoperable.	Unplug power cord. Check all wiring connections to be sure they are secure. Plug in power cord and wait 6 minutes. If error code returns, call Kenmore Water Line.

Questions? Call the Kenmore Water Line 1-800-426-9345 or visit [www.kenmorewater.com](http://www.kenmorewater.com)

# Service Information

## MANUALLY INITIATED ELECTRONIC DIAGNOSTICS

1. To enter diagnostics, press and hold the SELECT button until "000 - -" shows in the display.



Figure 32

**TURBINE OPERATION:** If no water is flowing through the softener, the turbine indicator displays three zeros. When water is flowing, a 000 to 199 count repeats for each gallon of water passing through the turbine. To check for positive operation of the turbine if zeros are shown, open a nearby soft water faucet and observe the turbine count. If you don't get a reading in the display with faucet open, pull the sensor housing from the valve outlet port (see Fig. 34). Pass a small magnet back and forth in front of the sensor. You should get a reading in the display. If you get a reading, unhook the inlet and outlet plumbing and check the turbine for binding.

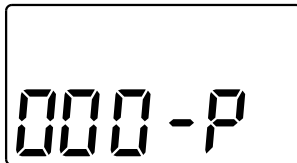

Figure 33

**POSITION SWITCH STATUS:** With the valve in service, or any of the recharge cycle positions, the position switch indicator will show two dashes (switch open). While the valve is rotating from one position to another, the position switch indicator will show the letter "P" (switch closed). There is likely a problem if indications vary from this pattern.

**OTHER INFORMATION:** While in the diagnostics screen, the following information is available and may be beneficial for various reasons. This information is retained by the electronic controller from the first time electrical power is applied to the unit.

- Press and hold the  $\triangle$  UP button to display the number of days this controller has had electrical power applied.
- Press and hold the  $\nabla$  DOWN button to display the number of regenerations initiated by this controller since the model code number was entered.

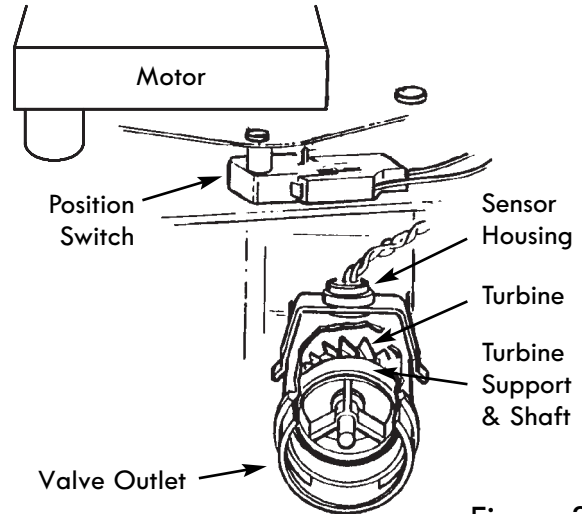

Figure 34

**NOTE:** If the electronic controller is left in the diagnostic display (or a flashing display when setting times or hardness), the normal time of day display automatically returns if a button has not been pressed for 4 minutes. To return to the diagnostic display, repeat step 1, above.

### RESETTING TO FACTORY DEFAULTS:

To reset the electronic controller to its factory default for all settings (time, hardness, etc.):

1. Press the SELECT button and hold it until the display changes twice to show "SET CODE" and the flashing model code.
2. Press the  $\triangle$  UP button to display a flashing "SoS".

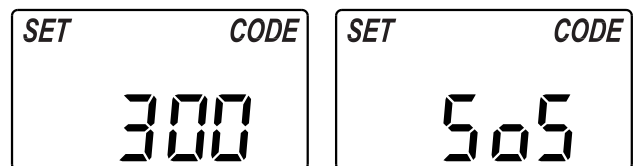

Figure 35

3. Press the SELECT button, and the electronic controller will restart.
4. Set the present time, hardness, etc., as described on pages 12 & 13.

# Service Information

## MANUAL ADVANCE REGENERATION CHECK

This check verifies proper operation of the valve motor, brine tank fill, brine draw, regeneration flow rates, and other controller functions. Always make the initial checks first, and perform the manually initiated electronic diagnostics.

**NOTE:** The display must show a steady time (not flashing). If an error code shows, first press the SELECT button to enter the diagnostic display.

1. Press the REGENERATION button and hold in for 3 seconds. "RECHARGE NOW" begins to flash in the display as the softener enters the fill cycle of regeneration.
2. When valve reaches "Fill" position, remove the brinewell cover and, using a flashlight, observe fill water entering the tank.
3. If water does not enter the tank, look for an obstructed nozzle, venturi, fill flow plug, brine tubing, or brine valve riser pipe.
4. After observing fill, press the REGENERATION button to move the softener into brining. A slow flow of water to the drain will begin. Verify brine draw from the brine tank by shining a flashlight into the brinewell and observing a noticeable drop in the liquid level.
5. If the softener does not draw brine:
  - nozzle and/or venturi dirty
  - nozzle and venturi not seated properly on gasket
  - restricted drain (check drain fitting and hose)
  - ineffective nozzle and venturi seal
  - other inner valve problem (rotor seal, rotor & disc, wave washer, etc.)

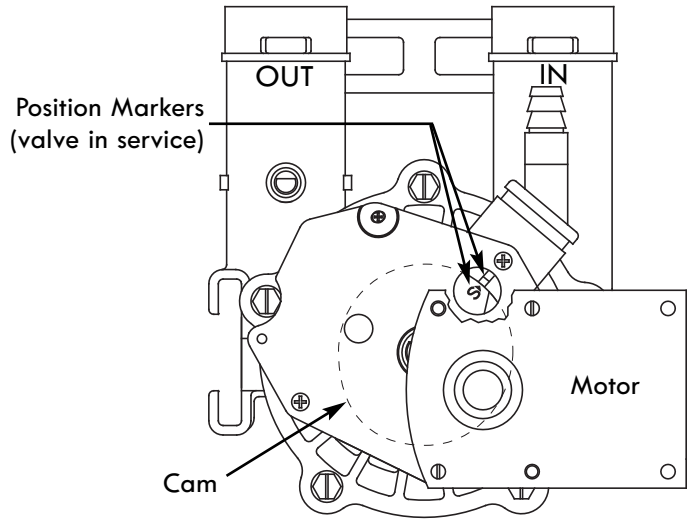

Figure 36

**NOTE:** If water system pressure is low, an elevated drain hose may cause back pressure, stopping brine draw.

6. Again press REGENERATION to move the softener into backwash. Look for a fast flow of water from the drain hose.
7. An obstructed flow indicates a plugged top distributor, backwash flow plug or drain hose.
8. Press REGENERATION to move the softener into fast rinse. Again look for a fast drain flow. Allow the softener to rinse for a few minutes to flush out any brine that may remain in the resin tank from the brining cycle test.
9. To return the softener to service, press REGENERATION once more.

## WIRING SCHEMATIC

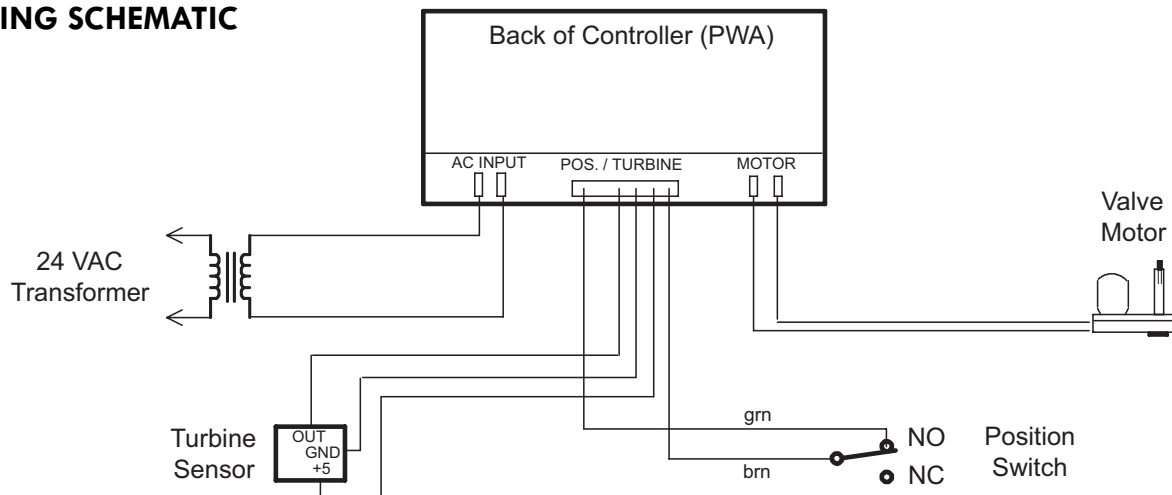

Figure 37

Questions? Call the Kenmore Water Line 1-800-426-9345 or visit [www.kenmorewater.com](http://www.kenmorewater.com)

# Notes

# Water Softener Exploded View

**Kenmore  
Model No.  
625.383000**

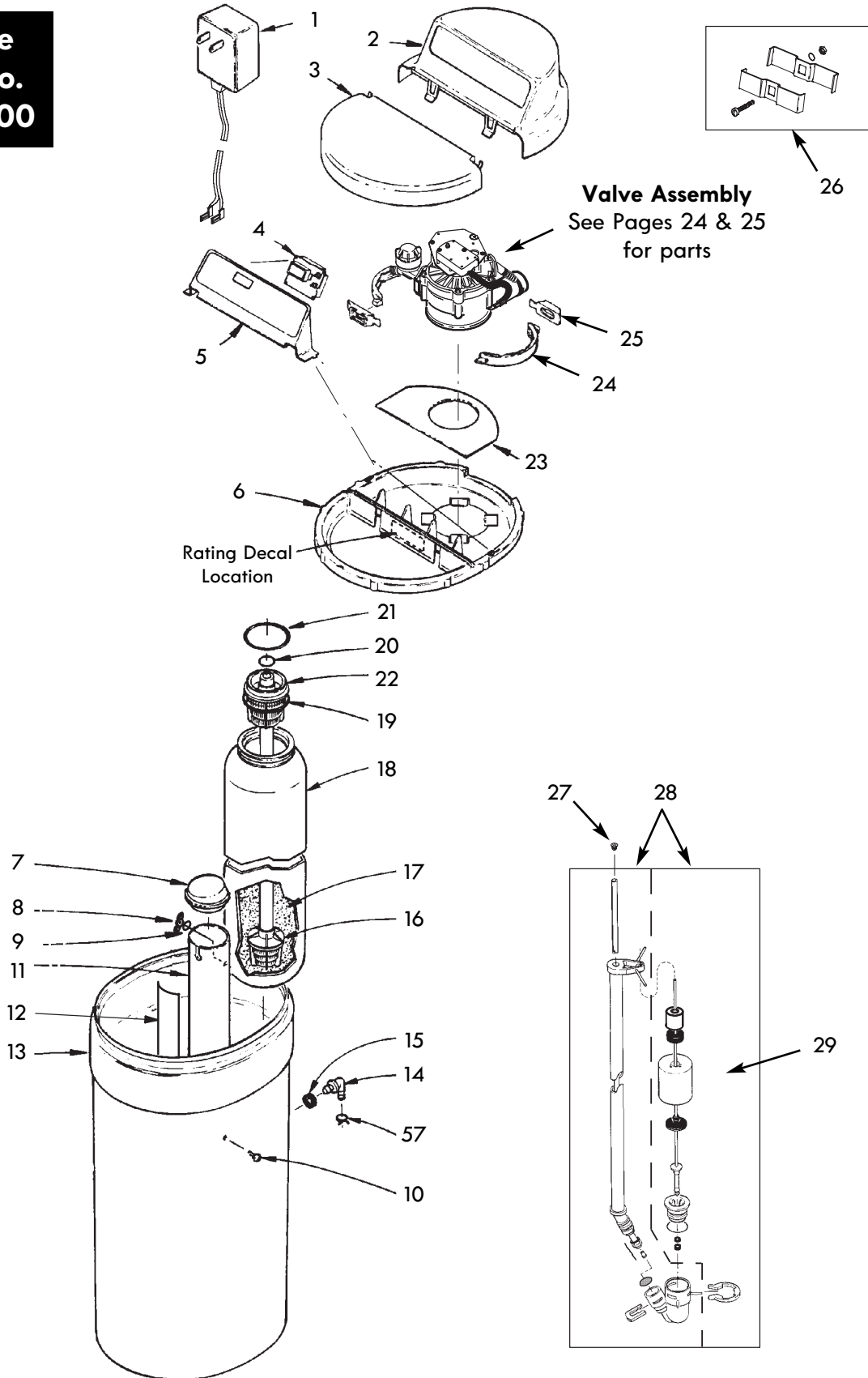

Questions? Call the Kenmore Water Line 1-800-426-9345 or visit [www.kenmorewater.com](http://www.kenmorewater.com)

# Softener Parts List

Key No.	Part No.	Description
1	7275907	Transformer, 24V, 10VA
2	7324926	Top Cover
3	7324934	Salt Lid (order decal below)
■	7325029	Instruction Decal, English
	7325061	Instruction Decal, Spanish
4	7327819	Repl. Electronic Controller (PWA)
5	7324918	Faceplate (order decal below)
■	7324950	Faceplate Decal
6	7324895	Rim
7	7219888	Brinewell Cover
■	7327576	Brinewell Mounting Hardware Kit (includes Key Nos. 8-10)
8	↑	Wing Nut, 1/4"
9	↑	O-Ring, 1/4" x 1/2"
10	↑	Plastic Screw, 1/4-20 x 5/8"
■	7214375	Brinewell Assembly (includes Key Nos. 11 & 12)
11	↑	Brinewell
12	↑	Decal, Salt Level
13	7324879	Salt Storage Tank
14	1103200	Adaptor Elbow
15	9003500	Grommet

Key No.	Part No.	Description
16	7327584	Repl. Bottom Distributor
17	0502272	Resin
18	7327607	Repl. Resin Tank, 7" x 40"
■	7112963	Distributor O-Ring Kit (includes Key Nos. 19-21)
19	↑	O-Ring, 2-3/4" x 3"
20	↑	O-Ring, 13/16" x 1-1/16"
21	↑	O-Ring, 2-7/8" x 3-1/4"
22	7077870	Top Distributor
23	7141001	Vapor Barrier
24	7176292	Clamp Section (2 req.)
25	7088033	Retainer Clip (2 req.)
26	7248706	Grounding Kit
27	7171349	Cone Screen
28	7310202	Brine Valve Assembly
29	7327568	Float, Guide & Stem Assembly *
■	3442707	Water Softener Cleaner *
■	7278573	Parts Bag (includes 5 ea. of Key No. 69, 2 ea. of Key Nos. 57 & 70, 1 ea. of Key Nos. 14, 15, 26 & 97)
■	7324976	Owner's Manual

■ Not illustrated.

\* Not included with water softener.

# Valve Assembly Exploded View

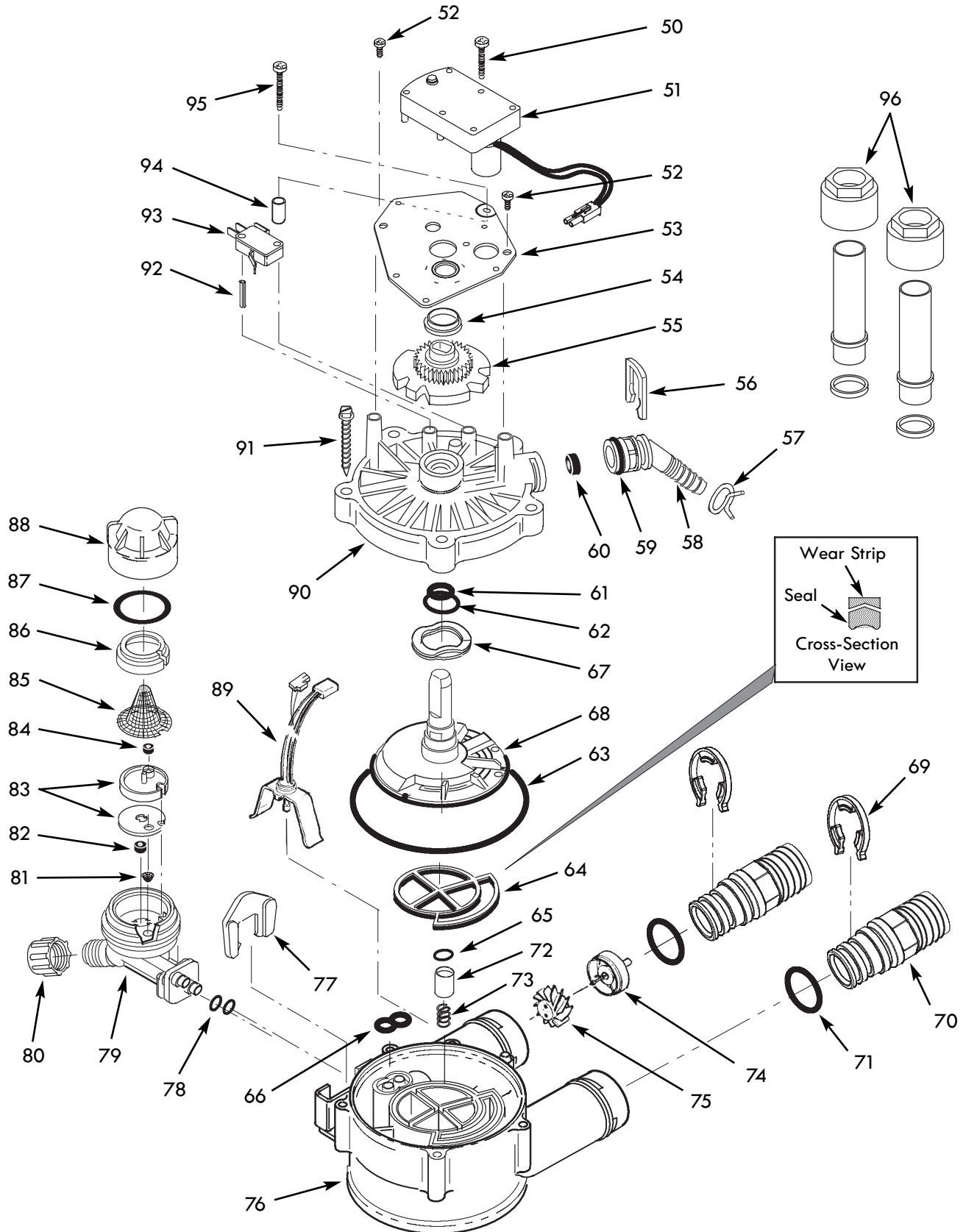

Questions? Call the Kenmore Water Line 1-800-426-9345 or visit [www.kenmorewater.com](http://www.kenmorewater.com)



# Valve Parts List

Key No.	Part No.	Description
50	7224087	Screw, #8-32 x 1" (2 req.)
51	7286039	Motor (incl. 2 ea. of Key No. 50)
52	0900857	Screw, #6-20 x 3/8" (2 req.)
53	7231385	Motor Plate
54	0503288	Bearing
55	7284964	Cam & Gear
56	7142942	Clip, Drain
57	0900431	Tubing Clamp (2 provided)
58	7024160	Adaptor, Drain Hose
59	7170327	O-Ring, 5/8" x 13/16"
60	0501226	Flow Plug, 0.9 gpm
■	7129716	Seal Kit, (includes Key Nos. 61-66)
61	↑	O-Ring, 7/16" x 5/8"
62	↑	O-Ring, 3/4" x 15/16"
63	↑	O-Ring, 3-3/8" x 3-5/8"
64	↑	Rotor Seal
65	↑	O-Ring, 3/8" x 9/16"
66	↑	Seal, Nozzle & Venturi
67	7082087	Bearing, Wave Washer
68	7199232	Rotor & Disc
69	7116713	Clip (4 req.)
70	7278442	Installation Adaptor, 1" NPT (2 req., includes 2 ea. of Key No. 71)
71	7170288	O-Ring 15/16" x 1-3/16" (2 req.)
72	7092642	Plug, Drain Seal
73	7129889	Spring
■	7113040	Turbine & Support Assembly (includes 1 ea. of Key Nos. 74, 75 & 2 ea. of Key No. 71)
74	↑	Turbine Support & Shaft
75	↑	Turbine

Key No.	Part No.	Description
76	7082053	Valve Body
77	7081201	Retainer, Nozzle & Venturi
78	7170319	O-Ring, 1/4" x 3/8" (2 req.)
79	7081104	Housing, Nozzle & Venturi
80	1202600	Nut - Ferrule
81	7095030	Cone Screen
82	1148800	Flow plug, 0.3 gpm
83	7187772	Nozzle & Venturi Gasket Kit
	7204362	Gasket (only)
84	0521829	Flow Plug, 0.1 gpm
85	7146043	Screen
86	7167659	Screen Support
87	7170262	O-Ring, 1-1/8" x 1-3/8"
88	7199729	Cap
89	7309803	Wire Harness (Sensor)
90	7085263	Valve Cover
91	7074123	Screw, #10-14 x 2" (5 req.)
92	7077472	Expansion Pin
93	7030713	Switch
94	7117816	Spacer
95	7070412	Screw, #4-24 x 1-1/8", Flat Head
96	7254260	Installation Adaptor Kit, (includes 2 ea. copper tubes, nuts, clips & washers) *
97	7278434	Bypass Valve Assembly (includes 2 ea. of Key No. 71)
■	7187065	Nozzle & Venturi Assembly (includes Key Nos. 79 & 81-88)
■	7139999	Drain Tubing, 3/8" I.D. x 20 ft.
■	7123613	Silicone Grease (for O-Rings) *
■	42-34405	Flexible Connectors, 3/4" *
■	42-34407	Flexible Connectors, 1" *

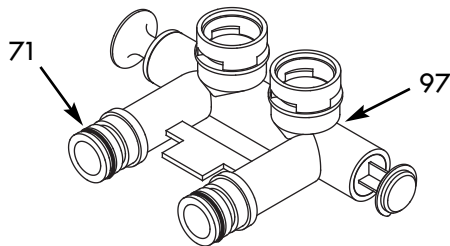

■ Not illustrated.

\* Not included with water softener.

Questions? Call the Kenmore Water Line 1-800-426-9345 or visit [www.kenmorewater.com](http://www.kenmorewater.com)

# Get it fixed, at your home or ours!

## Your Home

For expert troubleshooting and home solutions advice:



[www.managemylife.com](http://www.managemylife.com)

---

For repair – **in your home** – of **all** major brand appliances, lawn and garden equipment, or heating and cooling systems, **no matter who made it, no matter who sold it!**

For the replacement parts, accessories and owner's manuals that you need to do-it-yourself.

For Sears professional installation of home appliances and items like garage door openers and water heaters.

**1-800-4-MY-HOME<sup>®</sup>** (1-800-469-4663)

Call anytime, day or night (U.S.A. and Canada)

[www.sears.com](http://www.sears.com) [www.sears.ca](http://www.sears.ca)

---

## Our Home

For repair of carry-in items like vacuums, lawn equipment, and electronics, call anytime for the location of your nearest

**Sears Parts & Repair Service Center**

**1-800-488-1222** (U.S.A.)

[www.sears.com](http://www.sears.com)

**1-800-469-4663** (Canada)

[www.sears.ca](http://www.sears.ca)

---

To purchase a protection agreement on a product serviced by Sears:

**1-800-827-6655** (U.S.A.)

**1-800-361-6665** (Canada)

---

Para pedir servicio de reparación a domicilio, y para ordenar piezas:

**1-888-SU-HOGAR<sup>®</sup>**

(1-888-784-6427)

[www.sears.com](http://www.sears.com)

Au Canada pour service en français:

**1-800-LE-FOYER<sup>MC</sup>**

(1-800-533-6937)

[www.sears.ca](http://www.sears.ca)

The Sears logo, featuring the word "Sears" in a large, bold, serif font with a stylized 'S'.

© Registered Trademark / <sup>TM</sup> Trademark of KCD IP, LLC in the United States, or Sears Brands, LLC in other countries

© Marca Registrada / <sup>TM</sup> Marca de Fábrica de KCD IP, LLC en Estados Unidos, o Sears Brands, LLC en otros países

<sup>MC</sup> Marque de commerce / <sup>MD</sup> Marque déposée de Sears Brands, LLC