

CLICK ANYWHERE on THIS PAGE to RETURN to WATER & WELL PUMP MANUALS & INFORMATION at InspectApedia.com

Technical Data

Water Products

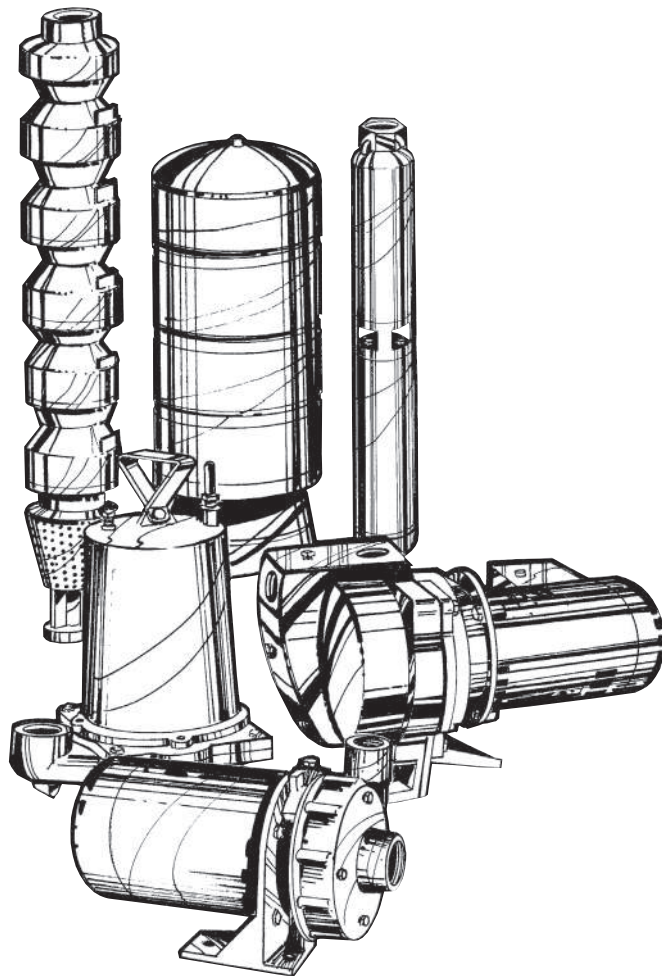

FRICITION LOSS

Plastic.....	1
Steel.....	2
Copper.....	3
Aluminum.....	4
Rubber Hose.....	4
Fittings.....	5
Offset Jet Pump Pipe Friction.....	5

JET AND SUBMERSIBLE PUMP SELECTION

Private Residences, Yard Fixtures, Public Buildings, Farm Use.....	6
Boiler Feed Requirements.....	6

TANK SELECTION

Hydro-Pro®.....	7
Galvanized.....	8
Capacities of Tanks of Various Dimensions.....	9

CENTRIFUGAL PUMP FUNDAMENTALS

NPSH and Cavitation.....	10
Vapor Pressure of Water.....	12

ELECTRICAL DATA

Transformer Sizes.....	13
Three Phase Unbalance.....	14
NEMA Panel Enclosures.....	15

DETERMINING WATER LEVEL

Determining Water Level.....	16
------------------------------	----

USE OF TAIL PIPE WITH JET PUMPS

Use of Tail Pipe with Jet Pumps.....	17
--------------------------------------	----

DETERMINING FLOW RATES

Full Pipe Flow.....	18
Pipe Not Running Full.....	18
Discharge Rate in Gallons per Minute.....	18
Theoretical Discharge of Nozzles in U.S. Gal. per Min.....	19

TERMS AND USABLE FORMULAS

Calculating Suction Lift.....	21
Definitions.....	22
Basic Formulas.....	22
Affinity Laws.....	24

CONVERSION CHARTS

Conversion Charts.....	25
------------------------	----

TYPICAL INSTALLATIONS

Jet – Deep and Shallow Well.....	29
Submersible – 4” Well.....	30
High Capacity Submersible.....	31
Centrifugal Booster.....	32
Jet Booster.....	33

PIPE VOLUME AND VELOCITY

Storage of Water in Various Size Pipes.....	34
Minimum Flow to Maintain 2 Ft./Sec.....	34
Storage of Water in Various Sizes of Wells.....	34

MOTOR DATA

Goolds Pumps and A.O. Smith Motor Data.....	35
Electrical Components.....	35
Terminal Board and Voltage Change Plug.....	36
Capacitor Start Induction Run – Motor Wiring.....	36

NOTE:

Submersible Motor Data moved to catalog “Motor Section”

EMERSON MOTOR WIRING

115/230 Voltage.....	37
----------------------	----

PRESSURE SWITCH WIRING AND ADJUSTMENTS

Square “D” Switches.....	38
Furnas Pro Control.....	38

WIRING DIAGRAMS

AWA501, AWA502.....	39
Power/Pump Connections: AWA501, AWA502.....	40

LOW YIELD WELL COMPONENTS

Components for a Low Yield Well with a Booster System.....	41
--	----

PLASTIC PIPE: FRICTION LOSS (IN FEET OF HEAD) PER 100 FT.

GPM	GPH	¾"	½"	¾"	1"	1¼"	1½"	2"	2½"	3"	4"	6"	8"	10"
		ft.	ft.	ft.	ft.	ft.	ft.	ft.	ft.	ft.	ft.	ft.	ft.	ft.
1	60	4.25	1.38	.356	.11									
2	120	15.13	4.83	1.21	.38	.10								
3	180	31.97	9.96	2.51	.77	.21	.10							
4	240	54.97	17.07	4.21	1.30	.35	.16							
5	300	84.41	25.76	6.33	1.92	.51	.24							
6	360		36.34	8.83	2.69	.71	.33	.10						
8	480		63.71	15.18	4.58	1.19	.55	.17						
10	600		97.52	25.98	6.88	1.78	.83	.25	.11					
15	900			49.68	14.63	3.75	1.74	.52	.22					
20	1,200			86.94	25.07	6.39	2.94	.86	.36	.13				
25	1,500				38.41	9.71	4.44	1.29	.54	.19				
30	1,800					13.62	6.26	1.81	.75	.26				
35	2,100					18.17	8.37	2.42	1.00	.35	.09			
40	2,400					23.55	10.70	3.11	1.28	.44	.12			
45	2,700					29.44	13.46	3.84	1.54	.55	.15			
50	3,000						16.45	4.67	1.93	.66	.17			
60	3,600						23.48	6.60	2.71	.93	.25			
70	4,200							8.83	3.66	1.24	.33			
80	4,800							11.43	4.67	1.58	.41			
90	5,400							14.26	5.82	1.98	.52			
100	6,000								7.11	2.42	.63	.08		
125	7,500								10.83	3.80	.95	.13		
150	9,000									5.15	1.33	.18		
175	10,500									6.90	1.78	.23		
200	12,000									8.90	2.27	.30		
250	15,000										3.36	.45	.12	
300	18,000										4.85	.63	.17	
350	21,000										6.53	.84	.22	
400	24,000											1.08	.28	
500	30,000											1.66	.42	.14
550	33,000											1.98	.50	.16
600	36,000											2.35	.59	.19
700	42,000												.79	.26
800	48,000												1.02	.33
900	54,000												1.27	.41
950	57,000													.46
1000	60,000													.50

STEEL PIPE: FRICTION LOSS (IN FEET OF HEAD) PER 100 FT.

GPM	GPH	3/8"	1/2"	3/4"	1"	1 1/4"	1 1/2"	2"	2 1/2"	3"	4"	5"	6"	8"	10"
		ft.	ft.	ft.	ft.	ft.	ft.	ft.	ft.	ft.	ft.	ft.	ft.	ft.	ft.
1	60	4.30	1.86	.26											
2	120	15.00	4.78	1.21	.38										
3	180	31.80	10.00	2.50	.77										
4	240	54.90	17.10	4.21	1.30	.34									
5	300	83.50	25.80	6.32	1.93	.51	.24								
6	360		36.50	8.87	2.68	.70	.33	.10							
7	420		48.70	11.80	3.56	.93	.44	.13							
8	480		62.70	15.00	4.54	1.18	.56	.17							
9	540			18.80	5.65	1.46	.69	.21							
10	600			23.00	6.86	1.77	.83	.25	.11	.04					
12	720			32.60	9.62	2.48	1.16	.34	.15	.05					
15	900			49.70	14.70	3.74	1.75	.52	.22	.08					
20	1,200			86.10	25.10	6.34	2.94	.87	.36	.13					
25	1,500				38.60	9.65	4.48	1.30	.54	.19					
30	1,800				54.60	13.60	6.26	1.82	.75	.26					
35	2,100				73.40	18.20	8.37	2.42	1.00	.35					
40	2,400				95.00	23.50	10.79	3.10	1.28	.44					
45	2,700					30.70	13.45	3.85	1.60	.55					
70	4,200					68.80	31.30	8.86	3.63	1.22	.35				
100	6,000						62.20	17.40	7.11	2.39	.63				
150	9,000							38.00	15.40	5.14	1.32				
200	12,000							66.30	26.70	8.90	2.27	.736	.30	.08	
250	15,000							90.70	42.80	14.10	3.60	1.20	.49	.13	
300	18,000								58.50	19.20	4.89	1.58	.64	.16	.0542
350	21,000								79.20	26.90	6.72	2.18	.88	.23	.0719
400	24,000								103.00	33.90	8.47	2.72	1.09	.279	.0917
450	27,000								130.00	42.75	10.65	3.47	1.36	.348	.114
500	30,000								160.00	52.50	13.00	4.16	1.66	.424	.138
550	33,000								193.00	63.20	15.70	4.98	1.99	.507	.164
600	36,000								230.00	74.80	18.60	5.88	2.34	.597	.192
650	39,000									87.50	21.70	6.87	2.73	.694	.224
700	42,000									101.00	25.00	7.93	3.13	.797	.256
750	45,000									116.00	28.60	9.05	3.57	.907	.291
800	48,000									131.00	32.40	10.22	4.03	1.02	.328
850	51,000									148.00	36.50	11.50	4.53	1.147	.368
900	54,000									165.00	40.80	12.90	5.05	1.27	.410
950	57,000									184.00	45.30	14.30	5.60	1.41	.455
1000	60,000									204.00	50.20	15.80	6.17	1.56	.500

COPPER PIPE: FRICTION LOSS (IN FEET OF HEAD) PER 100 FT.

GPM	GPH	3/8"	1/2"	3/4"	1"	1 1/4"	1 1/2"	2"	2 1/2"	3"	4"
		ft.	ft.	ft.	ft.	ft.	ft.	ft.	ft.	ft.	ft.
1	60	6.2	1.8	.39							
2	120	19.6	6.0	1.2							
5	300		30.0	5.8	1.6						
7	420		53.0	11.0	3.2	2.2					
10	600			19.6	5.3	3.9					
15	900			37.0	9.9	6.2	2.1				
18	1,080			55.4	16.1	6.9	3.2				
20	1,200				18.5	10.4	3.9				
25	1,500				27.7	14.3	5.3	1.5			
30	1,800				39.3	18.7	7.6	2.1			
35	2,100				48.5	25.4	10.2	2.8			
40	2,400					30.0	13.2	3.5	1.2		
45	2,700					39.3	16.2	4.2	1.6		
50	3,000						19.4	5.1	1.8		
60	3,600						27.7	6.9	2.5	1.1	
70	4,200						40.0	9.2	3.5	1.4	
75	4,500						41.6	9.9	3.7	1.6	
80	4,800						45.0	11.6	4.2	1.8	
90	5,400						50.8	13.9	4.8	2.2	
100	6,000							16.9	6.2	2.8	
125	7,500							25.4	8.6	3.7	
150	9,000							32.3	11.6	4.8	1.2
175	10,500							41.6	16.2	6.9	1.7
200	12,000							57.8	20.8	9.0	2.2
250	15,000								32.3	13.9	3.5
300	18,000								41.6	18.5	4.6
350	21,000									32.3	5.8
400	24,000									39.3	7.2
450	27,000									44.0	9.2
500	30,000										11.1
750	45,000										23.1
1000	60,000										37.0

ALUMINUM PIPE: FRICTION LOSS (IN FEET OF HEAD) PER 100 FT.

GPM	2" OD .05" Wall	3" OD .05" Wall	4" OD .063" Wall	5" OD .063" Wall	6" OD .063" Wall	7" OD .078" Wall	8" OD .094" Wall
5	.07						
10	.32	.04					
20	1.20	.15	.04				
30	2.58	.32	.08				
40	4.49	.56	.13	.04			
50	6.85	.85	.20	.07	.03		
60	9.67	1.21	.28	.09	.04		
70	12.95	1.61	.38	.12	.05		
80	16.70	2.06	.49	.16	.06	.03	
90	20.80	2.58	.60	.20	.08	.04	
100	25.40	3.18	.74	.24	.10	.05	.03
120		4.51	1.06	.34	.14	.07	.04
140		6.00	1.41	.46	.19	.09	.05
160		7.76	1.82	.59	.24	.11	.06
180		9.67	2.27	.73	.30	.14	.07
200		11.83	2.78	.89	.36	.17	.09
220		14.12	3.31	1.07	.44	.20	.11
240		16.72	3.91	1.27	.52	.24	.13
260		19.42	4.56	1.47	.60	.28	.15
280		22.40	5.26	1.71	.69	.33	.17
300		25.45	5.98	1.93	.79	.37	.19
350			8.03	2.59	1.05	.50	.26
400			10.36	3.33	1.35	.64	.33

GPM	2" OD .05" Wall	3" OD .05" Wall	4" OD .063" Wall	5" OD .063" Wall	6" OD .063" Wall	7" OD .078" Wall	8" OD .094" Wall
450			12.90	4.15	1.69	.80	.41
500			15.73	5.07	2.06	.97	.50
550			19.12	6.16	2.50	1.18	.62
600			22.46	7.24	2.94	1.38	.72
650			26.10	8.42	3.41	1.62	.84
700				9.68	3.92	1.86	.97
750				11.05	4.46	2.11	1.10
800				12.48	5.03	2.38	1.24
850				13.95	5.64	2.67	1.39
900				15.65	6.35	2.98	1.56
950				17.35	7.02	3.32	1.73
1000				19.10	7.72	3.64	1.90
1100				22.85	9.22	4.37	2.27
1200				26.95	10.88	5.16	2.68
1300					12.62	5.96	3.10
1400					14.65	6.90	3.60
1500					16.67	7.87	4.07
1600					18.80	8.89	4.62
1700					20.95	9.95	5.16
1800					23.60	11.15	5.79
1900						12.35	6.42
2000						13.65	7.10

(Above table computed for aluminum pipe with coupler.)

RUBBER HOSE: FRICTION LOSS (IN FEET OF HEAD) PER 100 FT.

GPM	Actual Inside Diameter in Inches							
	¾"	1"	1¼"	1½"	2"	2½"	3"	4"
15	70	23	5.8	2.5	.9	.2		
20	122	32	10	4.2	1.6	.5		
25	182	51	15	6.7	2.3	.7		
30	259	72	21.2	9.3	3.2	.9	.2	
40		122	35	15.5	5.5	1.4	.7	
50		185	55	23	8.3	2.3	1.2	
60		233	81	32	11.8	3.2	1.4	
70			104	44	15.2	4.2	1.8	
80			134	55	19.8	5.3	2.5	
90			164	70	25	7	3.5	.7
100			203	85	29	8.1	4	.9
125			305	127	46	12.2	5.8	1.4
150			422	180	62	17.3	8.1	1.6
175				230	85	23.1	10.6	2.5
200				308	106	30	13.6	3.2

GPM	Actual Inside Diameter in Inches							
	¾"	1"	1¼"	1½"	2"	2½"	3"	4"
250					162	44	21	4.9
300					219	62	28	6.7
350					292	83	39	9.3
400						106	49	11.8
500						163	74	17.1
600						242	106	23
700						344	143	30
800						440	182	40
900							224	51
1000							270	63
1250							394	100
1500							525	141
1750								185
2000								230

Goolds Pumps



EQUIVALENT NUMBER OF FEET STRAIGHT PIPE FOR DIFFERENT FITTINGS

Size of fittings, Inches	½"	¾"	1"	1¼"	1½"	2"	2½"	3"	4"	5"	6"	8"	10"
90° Ell	1.5	2.0	2.7	3.5	4.3	5.5	6.5	8.0	10.0	14.0	15	20	25
45° Ell	0.8	1.0	1.3	1.7	2.0	2.5	3.0	3.8	5.0	6.3	7.1	9.4	12
Long Sweep Ell	1.0	1.4	1.7	2.3	2.7	3.5	4.2	5.2	7.0	9.0	11.0	14.0	
Close Return Bend	3.6	5.0	6.0	8.3	10.0	13.0	15.0	18.0	24.0	31.0	37.0	39.0	
Tee-Straight Run	1	2	2	3	3	4	5						
Tee-Side Inlet or Outlet or Pitless Adapter	3.3	4.5	5.7	7.6	9.0	12.0	14.0	17.0	22.0	27.0	31.0	40.0	
Ball or Globe Valve Open	17.0	22.0	27.0	36.0	43.0	55.0	67.0	82.0	110.0	140.0	160.0	220.0	
Angle Valve Open	8.4	12.0	15.0	18.0	22.0	28.0	33.0	42.0	58.0	70.0	83.0	110.0	
Gate Valve-Fully Open	0.4	0.5	0.6	0.8	1.0	1.2	1.4	1.7	2.3	2.9	3.5	4.5	
Check Valve (Swing)	4	5	7	9	11	13	16	20	26	33	39	52	65
In Line Check Valve (Spring) or Foot Valve	4	6	8	12	14	19	23	32	43	58			

Example:

(A) 100 ft. of 2" plastic pipe with one (1) 90° elbow and one (1) swing check valve.

90° elbow – equivalent to 5.5 ft. of straight pipe
 Swing check – equivalent to 13.0 ft. of straight pipe
 100 ft. of pipe – equivalent to 100 ft. of straight pipe
 118.5 ft. = Total equivalent pipe

Figure friction loss for 118.5 ft. of pipe.

(B) Assume flow to be 80 GPM through 2" plastic pipe.

- Friction loss table shows 11.43 ft. loss per 100 ft. of pipe.
- In step (A) above we have determined total ft. of pipe to be 118.5 ft.
- Convert 118.5 ft. to percentage $118.5 \div 100 = 1.185$
- Multiply

11.43	
x 1.185	
13.54455	or 13.5 ft. = Total friction loss in this system.

OFFSET JET PUMP PIPE FRICTION

Where the jet pump is offset horizontally from the well site, add the following distances to the vertical lift to approximate capacity to be received.

PIPE FRICTION FOR OFFSET JET PUMPS

Friction Loss in Feet Per 100 Feet Offset

JET SIZE HP	SUCTION AND PRESSURE PIPE SIZES (in inches)									
	1¼ x 1	1¼ x 1¼	1½ x 1¼	1½ x 1½	2 x 1½	2 x 2	2½ x 2	2½ x 2½	3 x 2½	3 x 3
⅓	12	8	6	4						
½	18	12	8	6	3	2				
¾		22	16	11	6	4				
1			25	16	9	6				
1½					13	8	5	3		
2					20	13	7	5		
3							13	9	6	4

NOTE: Friction loss is to be added to vertical lift.

Goolds Pumps



PRIVATE RESIDENCES

Outlets	Flow Rate GPM	Total Usage Gallons	Bathrooms in Home			
			1	1½	2-2 ½	3-4
Shower or Bathtub	5	35	35	35	53	70
Lavatory	4	2	2	4	6	8
Toilet	4	5	5	10	15	20
Kitchen Sink	5	3	3	3	3	3
Automatic Washer	5	35	—	18	18	18
Dishwasher	2	14	—	—	3	3
Normal seven minute* peak demand (gallons)			45	70	98	122
Minimum sized pump required to meet peak demand without supplemental supply			7 GPM (420 GPH)	10 GPM (600 GPH)	14 GPM (840 GPH)	17 GPM (1020 GPH)

Notes:

Values given are average and do not include higher or lower extremes.

* Peak demand can occur several times during morning and evening hours.

** Count the number of fixtures in a home including outside hose bibs. Supply one gallon per minute each.

YARD FIXTURES

Garden Hose – ½" ¹ / ₂ "	3 GPM
Garden Hose – ¾" ³ / ₄ "	6 GPM
Sprinkler– Lawn	3-7 GPM

FARM USE

Horse, Steer	12 Gallons per day
Dry Cow	15 Gallons per day
Milking Cow	35 Gallons per day
Hog	4 Gallons per day
Sheep	2 Gallons per day
Chickens/100	6 Gallons per day
Turkeys/100	20 Gallons per day
Fire	20-60 GPM

PUBLIC BUILDINGS

Type of Building	Pump Capacity Required in U.S. Gallons per Minute per fixture for Public Buildings						
	Total Number of Fixtures						
	25 or Less	26-50	51-100	101-200	201-400	401-600	Over 600
Hospitals	1.00	1.00	.80	.60	.50	.45	.40
Mercantile Buildings	1.30	1.00	.80	.71	.60	.54	.48
Office Buildings	1.20	.90	.72	.65	.50	.40	.35
Schools	1.20	.85	.65	.60	.55	.45	
Hotels, Motels	.80	.60	.55	.45	.40	.35	.33
Apartment Buildings	.60	.50	.37	.30	.28	.25	.24

- For less than 25 fixtures, pump capacity should not be less than 75% of capacity required for 25 fixtures.
- Where additional water is required for some special process, this should be added to pump capacity.
- Where laundries or swimming pools are to be supplied, add approximately 10% to pump capacity for either.
- Where the majority of occupants are women, add approximately 20% to pump capacity.

BOILER FEED REQUIREMENTS

Boiler		Boiler		Boiler		Boiler		Boiler	
HP	GPM	HP	GPM	HP	GPM	HP	GPM	HP	GPM
20	1.38	55	3.80	90	6.21	160	11.1	275	19.0
25	1.73	60	4.14	100	6.90	170	11.7	300	20.7
30	2.07	65	4.49	110	7.59	180	12.4	325	22.5
35	2.42	70	4.83	120	8.29	190	13.1	350	24.2
40	2.76	75	5.18	130	8.97	200	13.8	400	27.6
45	3.11	80	5.52	140	9.66	225	15.5	450	31.1
50	3.45	85	5.87	150	10.4	250	17.3	500	34.5

1. Boiler Horsepower equals 34.5 lb. water evaporated at and from 212°F, and requires feed water at a rate of 0.069 gpm.

Select the boiler feed pump with a capacity of 2 to 3 times greater than the figures given above at a pressure 20 to 25% above that of boiler, because the table gives equivalents of boiler horsepower without reference to fluctuating demands.

Goolds Pumps



TABLE 1 – TANK MODELS

Model No.	Total Volume (Gals.)	Drawdown in Gals. at System Operating Pressure Range of			Max. Drawdown Vol. (Gals.)	Pre-Chgd. at: (lbs.)	System Connection	Dimensions		Shipping Weight	Height From Floor to Center of Base Opening
		20/40 PSIG	30/50 PSIG	40/60 PSIG				Diameter	Height		
V6P	2.0	0.7	0.6	0.5	1.2	38	¾" NPTM	8	11 ⁵ / ₁₆	7.5	
V15P	4.5	1.7	1.4	1.2	2.7	38	¾" NPTM	11	13 ⁵ / ₁₆	11.9	
V25P	8.2	3.1	2.6	2.2	4.5	38	¾" NPTM	11	23 ¹ / ₁₆	21.1	
V45P	13.9	5.1	4.3	3.7	8.4	38	1" NPTM	15 ³ / ₈	21 ¹ / ₁₆	23.8	
V45B	13.9	5.1	4.3	3.7	8.4	38	1" NPTM	15 ³ / ₈	21 ¹ / ₁₆	22.6	
V45	13.9	5.1	4.3	3.7	8.4	38	1" NPTF	15 ³ / ₈	24 ¹⁵ / ₁₆	23.4	3 ³ / ₈
V60B	19.9	7.3	6.1	5.3	12.1	38	1" NPTM	15 ³ / ₈	28 1/2	32.9	
V60	19.9	7.3	6.1	5.3	12.1	38	1" NPTF	15 ³ / ₈	32 ³ / ₈	33.7	3 ³ / ₈
V80	25.9	8.9	7.7	6.7	13.9	38	1" NPTF	15 ³ / ₈	39 ⁹ / ₁₆	43.0	
V80EX	25.9	8.9	7.7	6.7	13.9	38	1" NPTF	15 ³ / ₈	42 ³ / ₈	43.0	7 ¹ / ₄
V100	31.8	11.8	9.9	8.6	13.8	38	1" NPTF	15 ³ / ₈	47 ¹ / ₄	51.7	3 ³ / ₈
V100S	31.8	11.8	9.9	8.6	13.8	38	1" NPTF	22	28	51.7	3 ³ / ₈
V140B	45.2	16.5	13.9	12.1	27.3	38	1 ¹ / ₄ " NPTM	22	32 ³ / ₁₆	62.3	
V140	45.2	16.5	13.9	12.1	27.3	38	1 ¹ / ₄ " NPTF	22	36 ⁹ / ₁₆	64.1	3 ³ / ₈
V200B	65.1	23.9	20.0	17.4	39.3	38	1 ¹ / ₄ " NPTM	22	44 ¹ / ₄	86.9	
V200	65.1	23.9	20.0	17.4	39.3	38	1 ¹ / ₄ " NPTF	22	48 ³ / ₈	88.9	3 ³ / ₈
V250	83.5	30.9	25.9	22.5	50.8	38	1 ¹ / ₄ " NPTF	26	46	116.0	3 ¹ / ₂
V260	84.9	31.2	26.2	22.8	44.7	38	1 ¹ / ₄ " NPTF	22	60 ¹ / ₁₆	113.0	3 ³ / ₈
V350	115.9	42.9	35.9	31.3	70.5	38	1 ¹ / ₄ " NPTF	26	61 ¹ / ₁₆	161.0	3 ¹ / ₂

NOTES:
P = Pipe mounted
EX = Base extension
B = Buried
MP = Mounted pump
(All dimensions are in inches and weight in lbs. Do not use for construction purposes.)

TABLE 2 – PRESSURE FACTORS

		Pump Cut-In Pressure – PSIG																				
		20	25	30	35	40	45	50	55	60	65	70	75	80	85	90	95	100	105	110	115	
Pump Cut-Out Pressure – PSIG	30	.22																				
	35	.30	.20																			
	40	.37	.27	.18																		
	45	.42	.34	.25	.17																	
	50	.46	.39	.31	.23	.15																
	55	.50	.43	.36	.29	.22	.14															
	60	.54	.47	.40	.33	.27	.20	.13														
	65		.50	.44	.38	.31	.25	.19	.13													
	70		.53	.47	.41	.35	.30	.24	.18	.12												
	75			.50	.45	.39	.33	.28	.22	.17	.11											
	80			.53	.48	.42	.37	.32	.26	.21	.16	.11										
	85				.50	.45	.40	.35	.30	.25	.20	.15	.10									
	90				.53	.48	.43	.38	.33	.29	.24	.19	.14	.10								
	95					.50	.46	.41	.36	.32	.27	.23	.18	.14	.09							
	100					.52	.48	.44	.39	.35	.31	.26	.22	.17	.13	.09						
105						.50	.46	.42	.38	.33	.29	.25	.21	.17	.13	.08						
110						.52	.46	.44	.40	.36	.32	.28	.24	.20	.16	.12						
115							.50	.46	.42	.39	.35	.31	.27	.23	.19	.15	.12	.06				
120							.52	.48	.45	.41	.37	.33	.30	.26	.22	.19	.15	.11				
125								.50	.47	.43	.39	.36	.32	.29	.25	.21	.16	.14	.11	.07		

To determine tank drawdown of operating pressure ranges other than those listed in table, use following procedure:

Multiply total tank volume (table 1) by pressure factor (table 4).

Example: Operating range: 35/55
Tank being used: V-200

65.1 = Total volume of tank (table 1)
x .29 = Pressure factor (table 4)
18.9 = Drawdown in gallons at 35/55 PSI operating range.

VERTICAL TANK TABLE

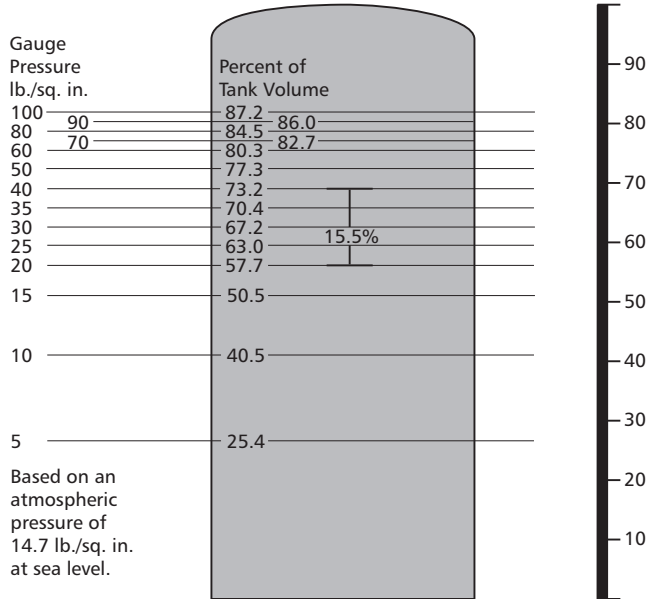

When using large standard galvanized tanks, a constant air cushion is required for proper operation of the water system.

The illustrations show the percent of tank volume as related to the pressure gauge reading. To determine the amount of water you will receive as drawoff from the tank, you should subtract the smaller number from the larger number to get the percentage. Then multiply by the size of the tank to get the gallons drawoff.

Example:

$$\begin{aligned}
 &50 \text{ lbs.} = 77.3 \\
 &\text{minus } 30 \text{ lbs.} = 67.2 \\
 &\qquad\qquad = 10.1\% \\
 &\quad \times 120 \text{ gallon size} \\
 &\qquad\qquad\qquad (\text{size of tank}) \\
 &\qquad\qquad\qquad = 12.12 \text{ gallons} \\
 &\qquad\qquad\qquad \text{drawoff}
 \end{aligned}$$

HORIZONTAL TANK TABLE

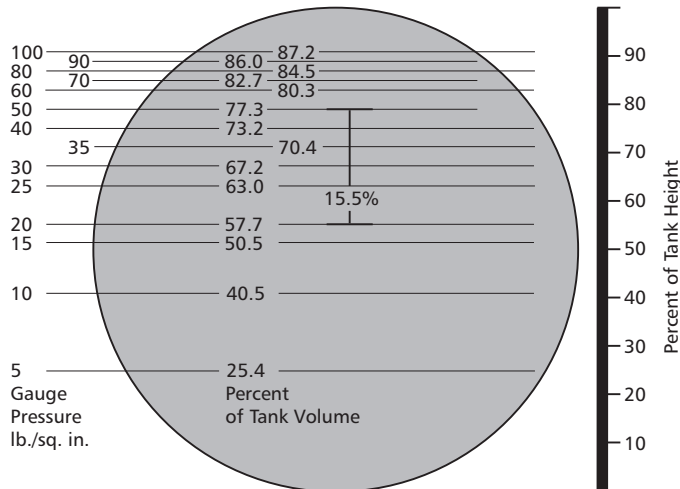

CAPACITIES OF TANKS OF VARIOUS DIMENSIONS

Dia. in inches	Length of Cylinder																		
	1"	1'	5'	6'	7'	8'	9'	10'	11'	12'	13'	14'	15'	16'	17'	18'	20'	22'	24'
1		0.04	0.20	0.24	0.28	0.32	0.36	0.40	0.44	0.48	0.52	0.56	0.60	0.64	0.68	0.72	0.80	0.88	0.96
2	0.01	0.16	0.80	0.96	1.12	1.28	1.44	1.60	1.76	1.92	2.08	2.24	2.40	2.56	2.72	2.88	3.20	3.52	3.84
3	0.03	0.37	1.84	2.20	2.56	2.92	3.30	3.68	4.04	4.40	4.76	5.12	5.48	5.84	6.22	6.60	7.36	8.08	8.80
4	0.05	0.65	3.26	3.92	4.58	5.24	5.88	6.52	7.18	7.84	8.50	9.16	9.82	10.5	11.1	11.8	13.0	14.4	15.7
5	0.08	1.02	5.10	6.12	7.14	8.16	9.18	10.2	11.2	12.2	13.3	14.3	15.3	16.3	17.3	18.4	20.4	22.4	24.4
6	0.12	1.47	7.34	8.80	10.3	11.8	13.2	14.7	16.1	17.6	19.1	20.6	22.0	23.6	25.0	26.4	29.4	32.2	35.2
7	0.17	2.00	10.0	12.0	14.0	16.0	18.0	20.0	22.0	24.0	26.0	28.0	30.0	32.0	34.0	36.0	40.0	44.0	48.0
8	0.22	2.61	13.0	15.6	18.2	20.8	23.4	26.0	28.6	31.2	33.8	36.4	39.0	41.6	44.2	46.8	52.0	57.2	62.4
9	0.28	3.31	16.5	19.8	23.1	26.4	29.8	33.0	36.4	39.6	43.0	46.2	49.6	52.8	56.2	60.0	66.0	72.4	79.2
10	0.34	4.08	20.4	24.4	28.4	32.6	36.8	40.8	44.8	48.8	52.8	56.8	61.0	65.2	69.4	73.6	81.6	89.6	97.6
11	0.41	4.94	24.6	29.6	34.6	39.4	44.4	49.2	54.2	59.2	64.2	69.2	74.0	78.8	83.8	88.8	98.4	104.0	118.0
12	0.49	5.88	29.4	35.2	41.0	46.8	52.8	58.8	64.6	70.4	76.2	82.0	87.8	93.6	99.6	106.0	118.0	129.0	141.0
13	0.57	6.90	34.6	41.6	48.6	55.2	62.2	69.2	76.2	83.2	90.2	97.2	104.0	110.0	117.0	124.0	138.0	152.0	166.0
14	0.67	8.00	40.0	48.0	56.0	64.0	72.0	80.0	88.0	96.0	104.0	112.0	120.0	128.0	136.0	144.0	160.0	176.0	192.0
15	0.77	9.18	46.0	55.2	64.4	73.6	82.8	92.0	101.0	110.0	120.0	129.0	138.0	147.0	156.0	166.0	184.0	202.0	220.0
16	0.87	10.4	52.0	62.4	72.8	83.2	93.6	104.0	114.0	125.0	135.0	146.0	156.0	166.0	177.0	187.0	208.0	229.0	250.0
17	0.98	11.8	59.0	70.8	81.6	94.4	106.0	118.0	130.0	142.0	153.0	163.0	177.0	189.0	201.0	212.0	236.0	260.0	283.0
18	1.10	13.2	66.0	79.2	92.4	106.0	119.0	132.0	145.0	158.0	172.0	185.0	198.0	211.0	224.0	240.0	264.0	290.0	317.0
19	1.23	14.7	73.6	88.4	103.0	118.0	132.0	147.0	162.0	177.0	192.0	206.0	221.0	235.0	250.0	265.0	294.0	324.0	354.0
20	1.36	16.3	81.6	98.0	114.0	130.0	147.0	163.0	180.0	196.0	212.0	229.0	245.0	261.0	277.0	294.0	326.0	359.0	392.0
21	1.50	18.0	90.0	108.0	126.0	144.0	162.0	180.0	198.0	216.0	238.0	252.0	270.0	288.0	306.0	324.0	360.0	396.0	432.0
22	1.65	19.8	99.0	119.0	139.0	158.0	178.0	198.0	218.0	238.0	257.0	277.0	297.0	317.0	337.0	356.0	396.0	436.0	476.0
23	1.80	21.6	108.0	130.0	151.0	173.0	194.0	216.0	238.0	259.0	281.0	302.0	324.0	346.0	367.0	389.0	432.0	476.0	518.0
24	1.96	23.5	118.0	141.0	165.0	188.0	212.0	235.0	259.0	282.0	306.0	330.0	353.0	376.0	400.0	424.0	470.0	518.0	564.0
25	2.12	25.5	128.0	153.0	179.0	204.0	230.0	255.0	281.0	306.0	332.0	358.0	383.0	408.0	434.0	460.0	510.0	562.0	612.0
26	2.30	27.6	138.0	166.0	193.0	221.0	248.0	276.0	304.0	331.0	359.0	386.0	414.0	442.0	470.0	496.0	552.0	608.0	662.0
27	2.48	29.7	148.0	178.0	208.0	238.0	267.0	297.0	326.0	356.0	386.0	416.0	426.0	476.0	504.0	534.0	594.0	652.0	712.0
28	2.67	32.0	160.0	192.0	224.0	256.0	288.0	320.0	352.0	384.0	416.0	448.0	480.0	512.0	544.0	576.0	640.0	704.0	768.0
29	2.86	34.3	171.0	206.0	240.0	274.0	309.0	343.0	377.0	412.0	446.0	480.0	514.0	548.0	584.0	618.0	686.0	754.0	824.0
30	3.06	36.7	183.0	220.0	257.0	294.0	330.0	367.0	404.0	440.0	476.0	514.0	550.0	588.0	624.0	660.0	734.0	808.0	880.0
32	3.48	41.8	209.0	251.0	293.0	334.0	376.0	418.0	460.0	502.0	544.0	586.0	628.0	668.0	710.0	752.0	836.0	920.0	1004.0
34	3.93	47.2	236.0	283.0	330.0	378.0	424.0	472.0	520.0	566.0	614.0	660.0	708.0	756.0	802.0	848.0	944.0	1040.0	1132.0
36	4.41	52.9	264.0	317.0	370.0	422.0	476.0	528.0	582.0	634.0	688.0	740.0	792.0	844.0	898.0	952.0	1056.0	1164.0	1268.0

Capacities, in U.S. Gallons, of cylinders of various diameters and lengths.

Volume = $\pi d^2 \times H$ (Cylinder), L x W x H (Cube)

4

NET POSITIVE SUCTION HEAD (NPSH) AND CAVITATION

The Hydraulic Institute defines NPSH as the total suction head in feet absolute, determined at the suction nozzle and corrected to datum, less the vapor pressure of the liquid in feet absolute. Simply stated, it is an analysis of energy conditions on the suction side of a pump to determine if the liquid will vaporize at the lowest pressure point in the pump.

The pressure which a liquid exerts on its surroundings is dependent upon its temperature. This pressure, called vapor pressure, is a unique characteristic of every fluid and increases with increasing temperature. When the vapor pressure within the fluid reaches the pressure of the surrounding medium, the fluid begins to vaporize or boil. The temperature at which this vaporization occurs will decrease as the pressure of the surrounding medium decreases.

A liquid increases greatly in volume when it vaporizes. One cubic foot of water at room temperature becomes 1700 cu. ft. of vapor at the same temperature.

It is obvious from the above that if we are to pump a fluid effectively, we must keep it in liquid form. NPSH is simply a measure of the amount of suction head present to prevent this vaporization at the lowest pressure point in the pump.

NPSH Required is a function of the pump design. As the liquid passes from the pump suction to the eye of the impeller, the velocity increases and the pressure decreases. There are also pressure losses due to shock and turbulence as the liquid strikes the impeller. The centrifugal force of the impeller vanes further increases the velocity and decreases the pressure of the liquid. The NPSH Required is the positive head in feet absolute required at the pump suction to overcome these pressure drops in the pump and maintain the liquid above its vapor pressure. The NPSH Required varies with speed and capacity within any particular pump. Pump manufacturer's curves normally provide this information.

NPSH Available is a function of the system in which the pump operates. It is the excess pressure of the liquid in feet absolute over its vapor pressure as it arrives at the pump suction. Fig. 4 shows four typical suction systems with the NPSH Available formulas applicable to each. It is important to correct for the specific gravity of the liquid and to convert all terms to units of "feet absolute" in using the formulas.

In an existing system, the NPSH Available can be determined by a gage reading on the pump suction. The following formula applies:

$$NPSH_A = P_B - V_p \pm Gr + h_v$$

Where Gr = Gage reading at the pump suction expressed in feet (plus if above atmospheric, minus if below atmospheric) corrected to the pump centerline.

h_v = Velocity head in the suction pipe at the gage connection, expressed in feet.

Cavitation is a term used to describe the phenomenon which occurs in a pump when there is insufficient NPSH Available. The pressure of the liquid is reduced to a value equal to or below its vapor pressure and small vapor bubbles or pockets begin to form. As these vapor bubbles move along the impeller vanes to a higher pressure area, they rapidly collapse.

The collapse, or "implosion" is so rapid that it may be heard as a rumbling noise, as if you were pumping gravel. The forces during the collapse are generally high enough to cause minute pockets of fatigue failure on the impeller vane surfaces. This action may be progressive, and under severe conditions can cause serious pitting damage to the impeller.

The accompanying noise is the easiest way to recognize cavitation. Besides impeller damage, cavitation normally results in reduced capacity due to the vapor present in the pump. Also, the head may be reduced and unstable and the power consumption may be erratic. Vibration and mechanical damage such as bearing failure can also occur as a result of operating in cavitation.

The only way to prevent the undesirable effects of cavitation is to insure that the NPSH Available in the system is greater than the NPSH Required by the pump.

NET POSITIVE SUCTION HEAD (NPSH) AND CAVITATION

4a SUCTION SUPPLY OPEN TO ATMOSPHERE
– with Suction Lift

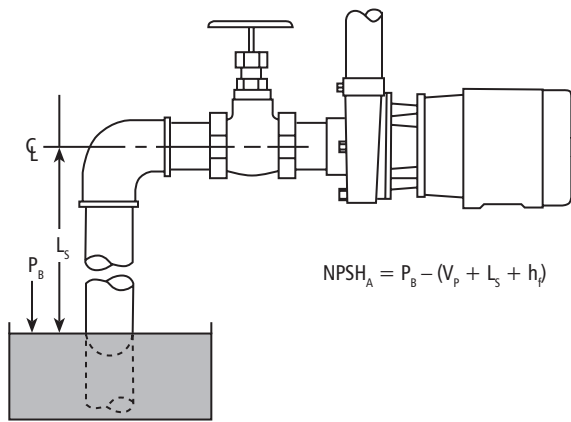

4b SUCTION SUPPLY OPEN TO ATMOSPHERE
– with Suction Head

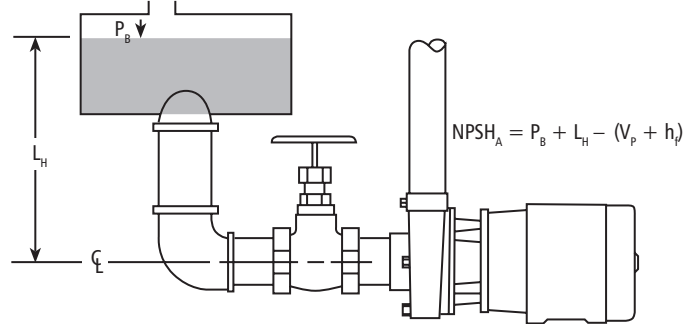

4c CLOSED SUCTION SUPPLY
– with Suction Lift

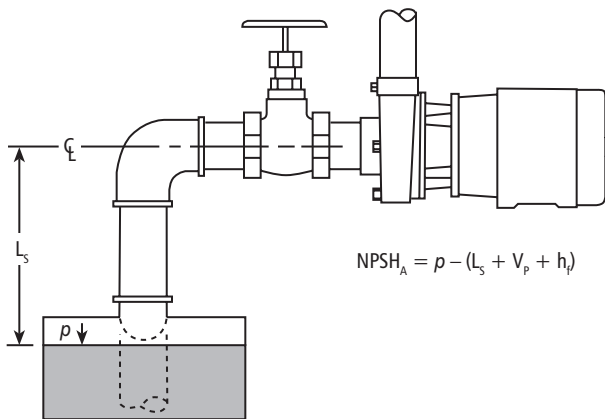

4d CLOSED SUCTION SUPPLY
– with Suction Head

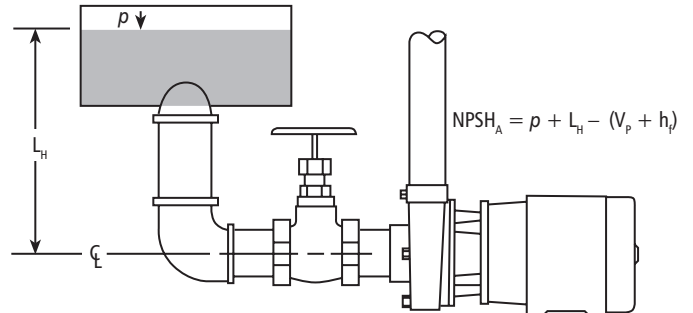

P_b = Barometric pressure, in feet absolute.

V_p = Vapor pressure of the liquid at maximum pumping temperature, in feet absolute (see next page).

p = Pressure on surface of liquid in closed suction tank, in feet absolute.

L_s = Maximum static suction lift in feet.

L_h = Minimum static suction head in feet.

h_f = Friction loss in feet in suction pipe at required capacity.

Note: See page 25, atmospheric pressure chart.

VAPOR PRESSURE OF WATER

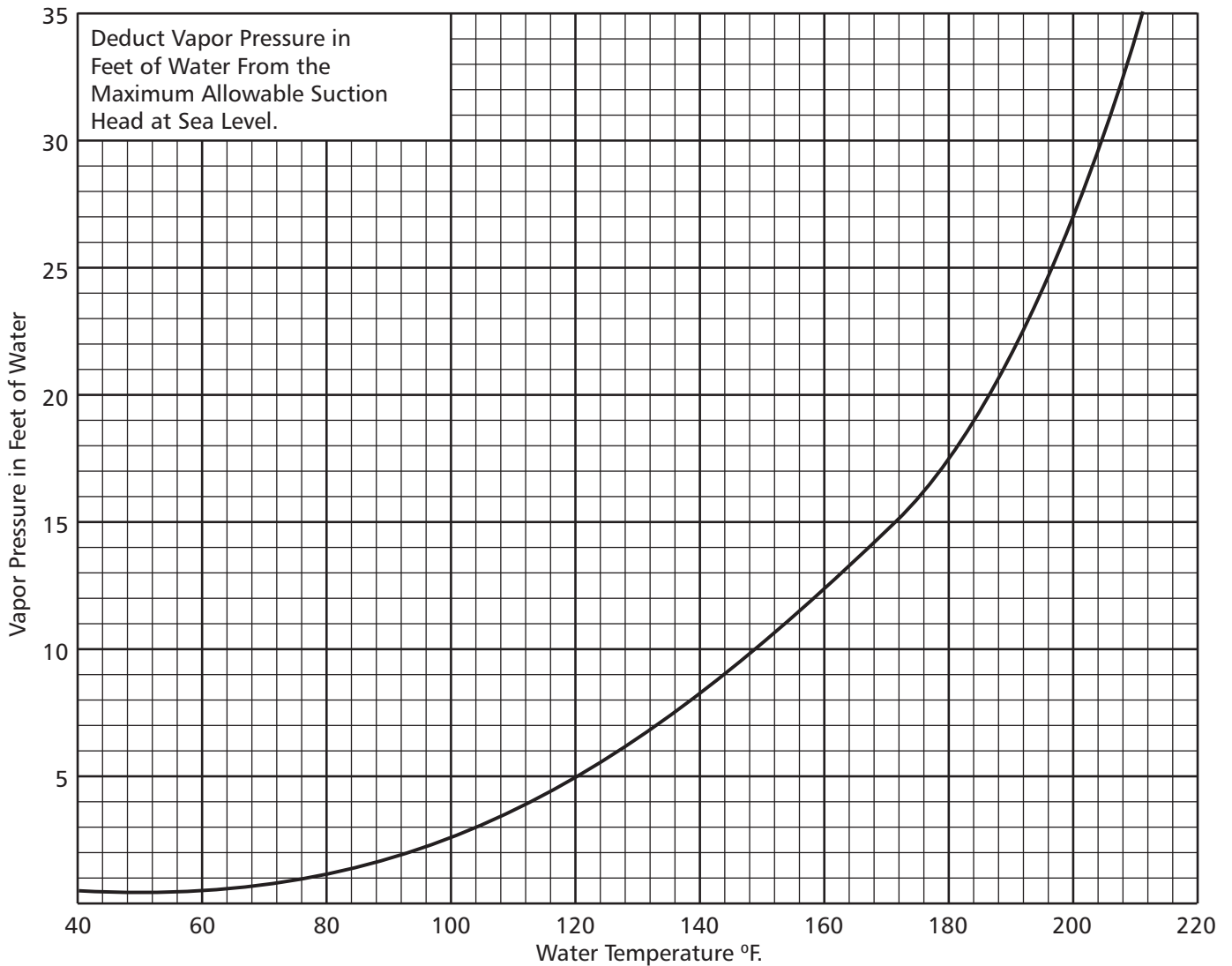

TRANSFORMER SIZES

A full three phase supply is recommended for all three phase motors, consisting of three individual transformers or one three phase transformer. "Open" delta or wye connections using only two transformers can be used, but are more likely to cause problems from current unbalance.

Transformer ratings should be no smaller than listed in the table for supply power to the motor alone.

TRANSFORMER CAPACITY REQUIRED FOR SUBMERSIBLE MOTORS

Submersible 3 ϕ Motor HP Rating	Total Effective KVA Required	Smallest KVA Rating – Each Transformer	
		Open WYE DELTA 2 Transformers	WYE or DELTA 3 Transformers
1½	3	2	1
2	4	2	1½
3	5	3	2
5	7½	5	3
7½	10	7½	5
10	15	10	5
15	20	15	7½
20	25	15	10
25	30	20	10
30	40	25	15
40	50	30	20
50	60	35	20
60	75	40	25
75	90	50	30
100	120	65	40

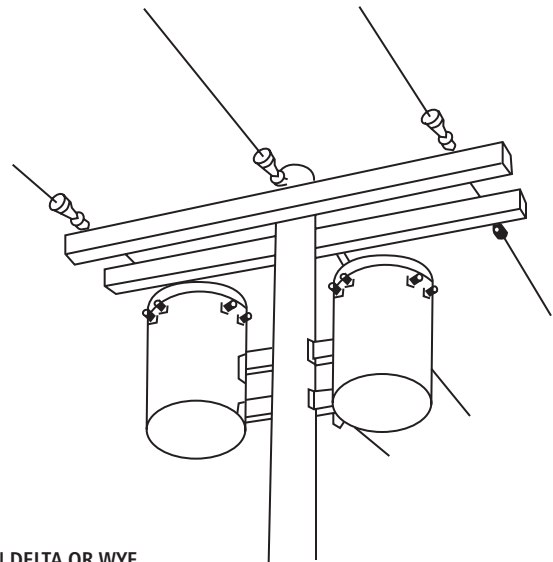

OPEN DELTA OR WYE

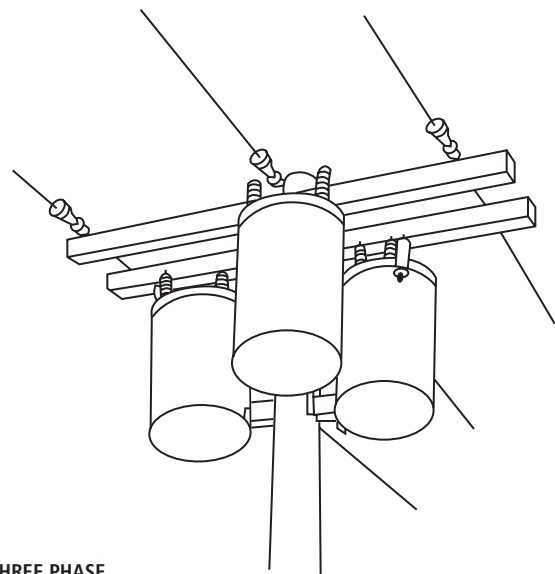

FULL THREE PHASE

Three Phase Motors

THREE PHASE POWER UNBALANCE

A full three phase supply is recommended for all three phase motors, consisting of three individual transformers or one three phase transformer. So-called "open" delta or wye connections using only two transformers can be used, but are more likely to cause problems, such as poor performance overload tripping or early motor failure due to current unbalance.

Transformer ratings should be no smaller than listed on Transformer Size Chart on previous page.

Checking and correcting rotation and current unbalance

1. Establish correct motor rotation by running in both directions. Change rotation by exchanging any two of the three motor leads. The rotation that gives the most water flow is always the correct rotation.

2. After correct rotation has been established, check the current in each of the three motor leads and calculate the current unbalance as explained in 3 below.

If the current unbalance is 2% or less, leave the leads as connected.

If the current unbalance is more than 2%, current readings should be checked on each leg using each of the three possible hook-ups. Roll the motor leads across the starter in the same direction to prevent motor reversal.

3. To calculate percent of current unbalance:
 A. Add the three line amp values together.
 B. Divide the sum by three, yielding average current.
 C. Pick the amp value which is furthest from the average current (either high or low).
 D. Determine the difference between this amp value (furthest from average) and the average.
 E. Divide the difference by the average.
 Multiply the result by 100 to determine percent of unbalance.

4. Current unbalance should not exceed 5% at service factor load or 10% at rated input load. If the unbalance cannot be corrected by rolling leads, the source of the unbalance must be located and corrected. If, on the three possible hookups, the leg farthest from the average stays on the same power lead, most of the unbalance is coming from the power source. However, if the reading farthest from average moves with the same motor lead, the primary source of unbalance is on the "motor side" of the starter. In this instance, consider a damaged cable, leaking splice, poor connection, or faulty motor winding.

Phase designation of leads for CCW rotation viewing shaft end.

To reverse rotation, interchange any two leads.

Phase 1 or "A" – Black Motor Lead or T1

Phase 2 or "B" – Yellow Motor Lead or T2

Phase 3 or "C" – Red Motor Lead or T3

Notice: Phase 1, 2 and 3 may not be L1, L2 and L3.

Starter Terminals	Hookup 1			Hookup 2			Hookup 3		
	L1	L2	L3	L1	L2	L3	L1	L2	L3
	⊥	⊥	⊥	⊥	⊥	⊥	⊥	⊥	⊥
	T1	T2	T3	T1	T2	T3	T1	T2	T3
Motor Leads	R	B	Y	Y	R	B	B	Y	R
	T3	T1	T2	T2	T3	T1	T1	T2	T3

Example:

T3-R = 51 amps	T2-Y = 50 amps	T1-B = 50 amps
T1-B = 46 amps	T3-R = 48 amps	T2-Y = 49 amps
T2-Y = 53 amps	T1-B = 52 amps	T3-R = 51 amps
Total = 150 amps	Total = 150 amps	Total = 150 amps
÷ 3 = 50 amps	÷ 3 = 50 amps	÷ 3 = 50 amps
— 46 = 4 amps	— 48 = 2 amps	— 49 = 1 amp
4 ÷ 50 = .08 or 8%	2 ÷ 50 = .04 or 4%	1 ÷ 50 = .02 or 2%

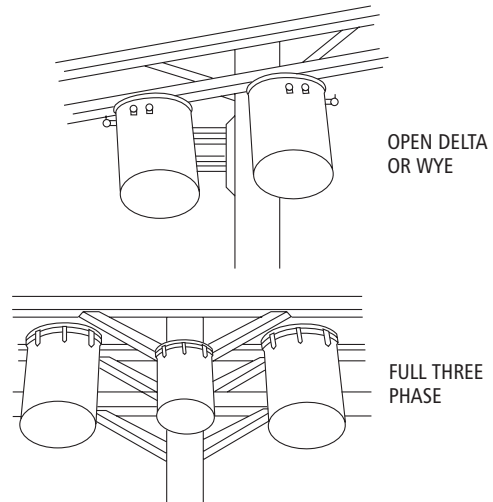

FIGURE 12

Goolds Pumps



NEMA CONTROL PANEL ENCLOSURES

Enclosure Rating	Explanation
NEMA 1 Purpose	To prevent accidental contact with enclosed apparatus. Suitable for application indoors where not General exposed to unusual service conditions.
NEMA 2 Driptight	To prevent accidental contact, and in addition, to exclude falling moisture or dirt.
NEMA 3 Weatherproof (Weatherproof Resistant)	Protection against specified weather hazards. Suitable for use outdoors.
NEMA 3R tight	Protects against entrance of water from a beating rain. Suitable for general outdoor application not Rain-requiring sleetproof.
NEMA 4 Watertight	Designed to exclude water applied in form of hose stream. To protect against stream of water during cleaning operations, etc.
NEMA 4X Watertight & Corrosion Resistant	Designed to exclude water applied in form of hose stream. To protect against stream of water during cleaning operations, etc. Corrosion Resistant.
NEMA 5 Dusttight	Constructed so that dust will not enter enclosed case. Being replaced in some equipment by Dust Tight NEMA 12.
NEMA 6 Watertight, Dusttight	Intended to permit enclosed apparatus to be operated successfully when temporarily submerged in water.
NEMA 7 Locations Class I	Designed to meet application requirements of National Electrical Code for Class 1, Hazardous Hazardous Locations (explosive atmospheres). Circuit interruption occurs in air.
NEMA 8 Hazardous Locations A, B, C or D Class II – Oil Immersed	Identical to NEMA 7 above, except the apparatus is immersed in oil.
NEMA 9 Class II – Locations	Designed to meet application requirements of National Electrical Code for Class II Hazardous Hazardous Locations (combustible dusts, etc.). E, F and G.
NEMA 10 Bureau of Mines Permissible	Meets requirements of U.S. Bureau of Mines. Suitable for use in coal mines.
NEMA 11 Dripproof Corrosion Resistant	Provides oil immersion of apparatus such that it is suitable for application where equipment is subject to acid or other corrosive fumes.
NEMA 12 Driptight, Dusttight	For use in those industries where it is desired to exclude dust, lint, fibers and flyings, or oil or Industrial coolant seepage.

Install 1/8" or 1/4" tubing long enough to be 10' to 15' below low water level. Measure the tubing length as it is lowered into the well.

Once the tubing is fixed in a stationary position at the top, connect an air line and pressure gauge. Add air to the tubing until the pressure gauge reaches a point that it doesn't read any higher. Take a gauge reading at this point.

- A. Depth to water (to be determined).
- B. Total length of air line (in feet).
- C. Water pressure on air tubing. Gauge reads in pounds. Convert to feet by multiplying by 2.31.

Example:

If the air tube is 100' long,
 and the gauge reads 20 lbs.
 $20 \text{ lbs.} \times 2.31 = 46.2 \text{ ft.}$
 Length of tube = 100 ft.
 minus 46.2 ft. = 53.8 ft.
 Depth to water (A) would
 be 53.8 ft.

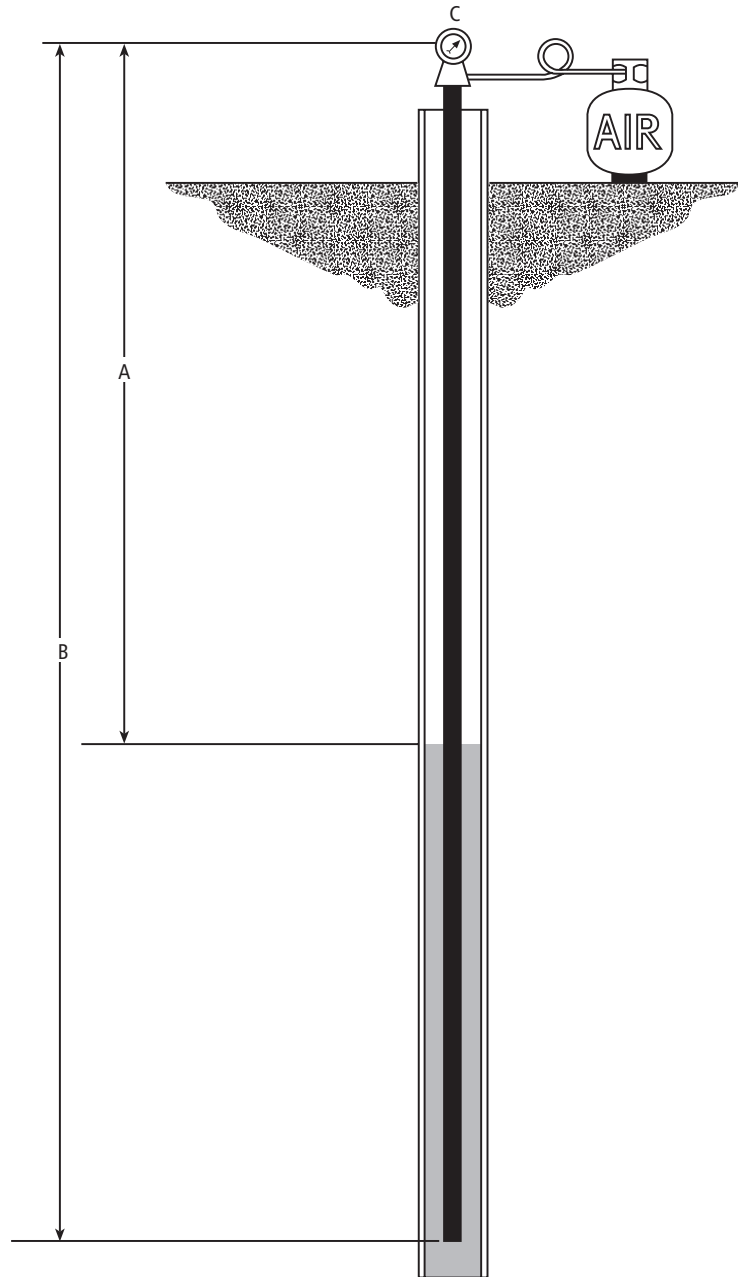

HOW TO USE TAIL PIPE ON DEEP WELL JET PUMPS

Pipe below the jet, or "tail pipe" as it is commonly known, is used when you have a weak deep well. Under normal conditions, the jet assembly with the foot valve attached is lowered into the well. You receive your rated capacity at the level you locate the jet assembly. On a weak well, as the water level lowers to the level of the foot valve (attached to the bottom of the jet assembly), air enters the system. By adding 34' of tail pipe below the jet assembly with the foot valve attached to the bottom of the 34' length of pipe, it will not be possible to pull the well down and allow air to enter the system. The drawing indicates the approximate percentage of rated capacity you will receive with tail pipe.

Using a tail pipe, the pump delivery remains at 100% at sea level of the rated capacity down to the jet assembly level. If water level falls below that, flow decreases in proportion to drawdown as shown in the illustration. When pump delivery equals well inflow, the water level remains constant until the pump shuts off. This rule can also be used when determining suction pipe length on shallow well systems.

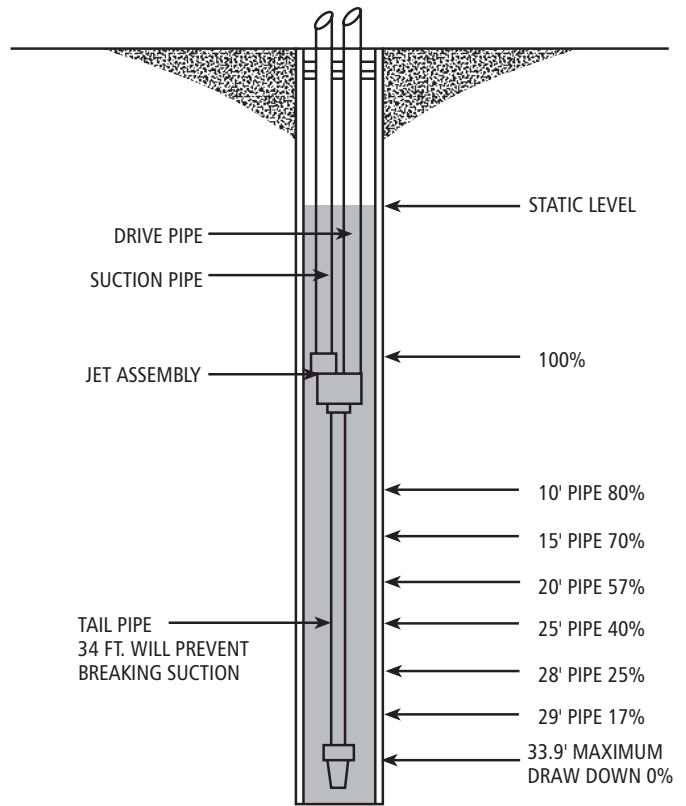

FULL PIPE FLOW – CALCULATION OF DISCHARGE RATE USING HORIZONTAL OPEN DISCHARGE FORMULA

An L-shaped measuring square can be used to estimate flow capacity, using the chart below. As shown in illustration, place 4" side of square so that it hangs down and touches the water. The horizontal distance shown "A" is located in the first column of the chart and you read across to the pipe diameter (ID) to find the gallons per minute discharge rate.

Example: A is 8" from a 4" ID pipe = a discharge rate of 166 GPM.

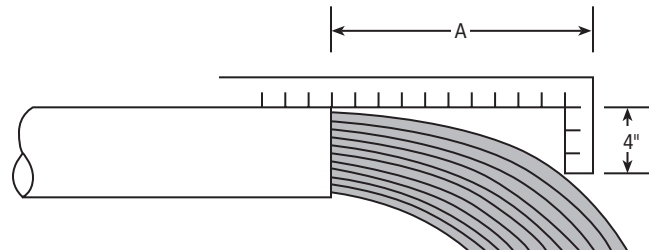

PIPE NOT RUNNING FULL – CALCULATION OF DISCHARGE RATE USING AREA FACTOR METHOD

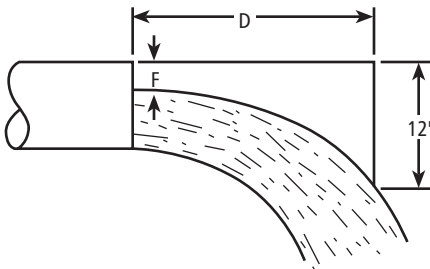

Flow From Horizontal Pipe (Not Full)

Flow (GPM) = $A \times D \times 1.093 \times F$
 A = Area of pipe in square inches
 D = Horizontal distance in inches
 F = Effective area factor shown below
 Area of pipe equals inside Dia.² x 0.7854

Example:
 D = 20 inches – Pipe inside diameter = 10 inches –
 F = 2 1/2 inches
 A = 10 x 10 x 0.7854 = 78.54 square inches
 R = 2 1/2 / 10 = 25%
 F = 0.805
 Flow = 78.54 x 20 x 1.039 x 0.805 = 1314 GPM

Ratio F/D = R %	Eff. Area Factor F	Ratio F/D = R %	Eff. Area Factor F
5	0.981	55	0.436
10	0.948	60	0.373
15	0.905	65	0.312
20	0.858	70	0.253
25	0.805	75	0.195
30	0.747	80	0.142
35	0.688	85	0.095
40	0.627	90	0.052
45	0.564	95	0.019
50	0.500	100	0.000

DISCHARGE RATE IN GALLONS PER MINUTE/NOMINAL PIPE SIZE (ID)

Horizontal Dist. (A) Inches	1"	1 1/4"	1 1/2"	2"	2 1/2"	3"	4"	5"	6"	8"	10"	12"
4	5.7	9.8	13.3	22.0	31.3	48.5	83.5					
5	7.1	12.2	16.6	27.5	39.0	61.0	104	163				
6	8.5	14.7	20.0	33.0	47.0	73.0	125	195	285			
7	10.0	17.1	23.2	38.5	55.0	85.0	146	228	334	380		
8	11.3	19.6	26.5	44.0	62.5	97.5	166	260	380	665	1060	
9	12.8	22.0	29.8	49.5	70.0	110	187	293	430	750	1190	1660
10	14.2	24.5	33.2	55.5	78.2	122	208	326	476	830	1330	1850
11	15.6	27.0	36.5	60.5	86.0	134	229	360	525	915	1460	2100
12	17.0	29.0	40.0	66.0	94.0	146	250	390	570	1000	1600	2220
13	18.5	31.5	43.0	71.5	102	158	270	425	620	1080	1730	2400
14	20.0	34.0	46.5	77.0	109	170	292	456	670	1160	1860	2590
15	21.3	36.3	50.0	82.5	117	183	312	490	710	1250	2000	2780
16	22.7	39.0	53.0	88.0	125	196	334	520	760	1330	2120	2960
17		41.5	56.5	93.0	133	207	355	550	810	1410	2260	3140
18			60.0	99.0	144	220	375	590	860	1500	2390	3330
19				110	148	232	395	620	910	1580	2520	3500
20					156	244	415	650	950	1660	2660	3700
21						256	435	685	1000	1750	2800	
22							460	720	1050	1830	2920	
23								750	1100	1910	3060	
24									1140	2000	3200	

THEORETICAL DISCHARGE OF NOZZLES IN U.S. GALLONS PER MINUTE

Head		Velocity of Discharge Feet Per Second	Diameter of Nozzle in Inches								
Pounds	Feet		1/16	1/8	3/16	1/4	3/8	1/2	5/8	3/4	7/8
10	23.1	38.6	0.37	1.48	3.32	5.91	13.3	23.6	36.9	53.1	72.4
15	34.6	47.25	0.45	1.81	4.06	7.24	16.3	28.9	45.2	65.0	88.5
20	46.2	54.55	0.52	2.09	4.69	8.35	18.8	33.4	52.2	75.1	102
25	57.7	61.0	0.58	2.34	5.25	9.34	21.0	37.3	58.3	84.0	114
30	69.3	66.85	0.64	2.56	5.75	10.2	23.0	40.9	63.9	92.0	125
35	80.8	72.2	0.69	2.77	6.21	11.1	24.8	44.2	69.0	99.5	135
40	92.4	77.2	0.74	2.96	6.64	11.8	26.6	47.3	73.8	106	145
45	103.9	81.8	0.78	3.13	7.03	12.5	28.2	50.1	78.2	113	153
50	115.5	86.25	0.83	3.30	7.41	13.2	29.7	52.8	82.5	119	162
55	127.0	90.4	0.87	3.46	7.77	13.8	31.1	55.3	86.4	125	169
60	138.6	94.5	0.90	3.62	8.12	14.5	32.5	57.8	90.4	130	177
65	150.1	98.3	0.94	3.77	8.45	15.1	33.8	60.2	94.0	136	184
70	161.7	102.1	0.98	3.91	8.78	15.7	35.2	62.5	97.7	141	191
75	173.2	105.7	1.01	4.05	9.08	16.2	36.4	64.7	101	146	198
80	184.8	109.1	1.05	4.18	9.39	16.7	37.6	66.8	104	150	205
85	196.3	112.5	1.08	4.31	9.67	17.3	38.8	68.9	108	155	211
90	207.9	115.8	1.11	4.43	9.95	17.7	39.9	70.8	111	160	217
95	219.4	119.0	1.14	4.56	10.2	18.2	41.0	72.8	114	164	223
100	230.9	122.0	1.17	4.67	10.5	18.7	42.1	74.7	117	168	229
105	242.4	125.0	1.20	4.79	10.8	19.2	43.1	76.5	120	172	234
110	254.0	128.0	1.23	4.90	11.0	19.6	44.1	78.4	122	176	240
115	265.5	130.9	1.25	5.01	11.2	20.0	45.1	80.1	125	180	245
120	277.1	133.7	1.28	5.12	11.5	20.5	46.0	81.8	128	184	251
125	288.6	136.4	1.31	5.22	11.7	20.9	47.0	83.5	130	188	256
130	300.2	139.1	1.33	5.33	12.0	21.3	48.0	85.2	133	192	261
135	311.7	141.8	1.36	5.43	12.2	21.7	48.9	86.7	136	195	266
140	323.3	144.3	1.38	5.53	12.4	22.1	49.8	88.4	138	199	271
145	334.8	146.9	1.41	5.62	12.6	22.5	50.6	89.9	140	202	275
150	346.4	149.5	1.43	5.72	12.9	22.9	51.5	91.5	143	206	280
175	404.1	161.4	1.55	6.18	13.9	24.7	55.6	98.8	154	222	302
200	461.9	172.6	1.65	6.61	14.8	26.4	59.5	106	165	238	323

Note:

The actual quantities will vary from these figures, the amount of variation depending upon the shape of nozzle and size of pipe at the point where the pressure is determined. With smooth taper nozzles the actual discharge is about 94 percent of the figures given in the tables.

THEORETICAL DISCHARGE OF NOZZLES IN U.S. GALLONS PER MINUTE (continued)

Head		Velocity of Discharge Feet Per Second	Diameter of Nozzle in Inches								
Pounds	Feet		1	1 ¹ / ₈	1 ¹ / ₄	1 ³ / ₈	1 ¹ / ₂	1 ³ / ₄	2	2 ¹ / ₄	2 ¹ / ₂
10	23.1	38.6	94.5	120	148	179	213	289	378	479	591
15	34.6	47.25	116	147	181	219	260	354	463	585	723
20	46.2	54.55	134	169	209	253	301	409	535	676	835
25	57.7	61.0	149	189	234	283	336	458	598	756	934
30	69.3	66.85	164	207	256	309	368	501	655	828	1023
35	80.8	72.2	177	224	277	334	398	541	708	895	1106
40	92.4	77.2	188	239	296	357	425	578	756	957	1182
45	103.9	81.8	200	253	313	379	451	613	801	1015	1252
50	115.5	86.25	211	267	330	399	475	647	845	1070	1320
55	127.0	90.4	221	280	346	418	498	678	886	1121	1385
60	138.6	94.5	231	293	362	438	521	708	926	1172	1447
65	150.1	98.3	241	305	376	455	542	737	964	1220	1506
70	161.7	102.1	250	317	391	473	563	765	1001	1267	1565
75	173.2	105.7	259	327	404	489	582	792	1037	1310	1619
80	184.8	109.1	267	338	418	505	602	818	1070	1354	1672
85	196.3	112.5	276	349	431	521	620	844	1103	1395	1723
90	207.9	115.8	284	359	443	536	638	868	1136	1436	1773
95	219.4	119.0	292	369	456	551	656	892	1168	1476	1824
100	230.9	122.0	299	378	467	565	672	915	1196	1512	1870
105	242.4	125.0	306	388	479	579	689	937	1226	1550	1916
110	254.0	128.0	314	397	490	593	705	960	1255	1588	1961
115	265.5	130.9	320	406	501	606	720	980	1282	1621	2005
120	277.1	133.7	327	414	512	619	736	1002	1310	1659	2050
125	288.6	136.4	334	423	522	632	751	1022	1338	1690	2090
130	300.2	139.1	341	432	533	645	767	1043	1365	1726	2132
135	311.7	141.8	347	439	543	656	780	1063	1390	1759	2173
140	323.3	144.3	354	448	553	668	795	1082	1415	1790	2212
145	334.8	146.9	360	455	562	680	809	1100	1440	1820	2250
150	346.4	149.5	366	463	572	692	824	1120	1466	1853	2290
175	404.1	161.4	395	500	618	747	890	1210	1582	2000	2473
200	461.9	172.6	423	535	660	790	950	1294	1691	2140	2645

Note:

The actual quantities will vary from these figures, the amount of variation depending upon the shape of nozzle and size of pipe at the point where the pressure is determined. With smooth taper nozzles the actual discharge is about 94 percent of the figures given in the tables.

CALCULATING SUCTION LIFT

Suction lift is measured with a vacuum gauge. The gauge can be calibrated in feet suction lift or inches vacuum.

A. 1 inch vacuum equals 1.13 feet suction lift.

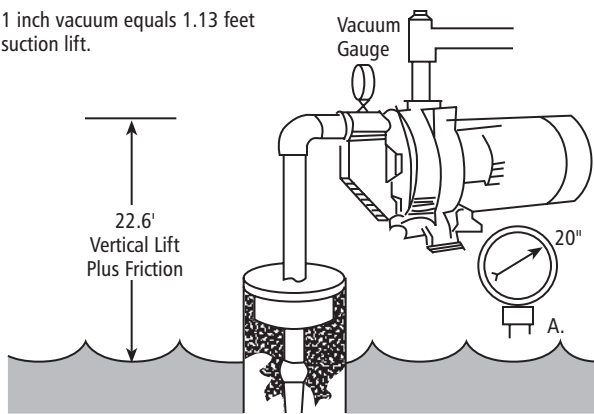

A reading of 20" on a vacuum gauge placed on the suction side of the pump would tell you that you had a vacuum or suction lift of 22.6 feet.

$$20" \times 1.13' = 22.6 \text{ feet}$$

C. Atmospheric pressure of $14.7 \times 2.31 = 33.9$ feet which is the maximum suction lift at sea level.

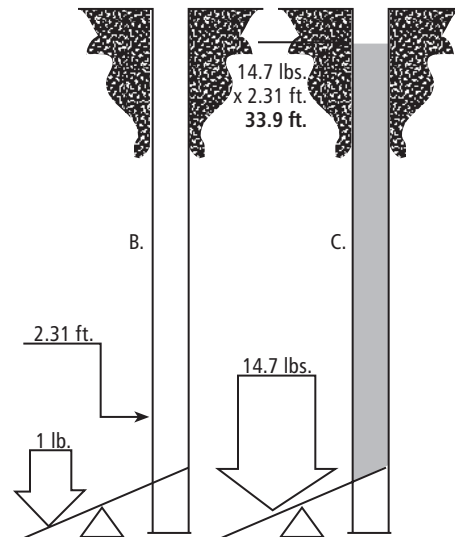

A vacuum gauge indicates total suction lift (vertical lift + friction loss = total lift) in inches of mercury. 1" on the gauge = 1.13 ft. of total suction lift (based on pump located at sea level).

RULE OF THUMB

Practical suction lift at sea level is 25 ft. Deduct 1 ft. of suction lift for each 1000 ft. of elevation above sea level.

Shallow Well System

Install vacuum gauge in shallow well adapter. When pump is running, the gauge will show no vacuum if the end of suction pipe is not submerged or there is a suction leak. If the gauge shows a

very high vacuum (22 inches or more), this indicates that the end of suction pipe is buried in mud, the foot valve or check valve is stuck closed or the suction lift exceeds capability of pump.

High Vacuum (22 inches or more)

- Suction pipe end buried in mud
- Foot valve or check valve stuck closed
- Suction lift exceeds capability of the pump

Low Vacuum (or 0 vacuum)

- Suction pipe not submerged
- Suction leak

The term "head" by itself is rather misleading. It is commonly taken to mean the difference in elevation between the suction level and the discharge level of the liquid being pumped. Although this is partially correct, it does not include all of the conditions that should be included to give an accurate description.

■ **Friction Head:**

The pressure expressed in lbs./sq. in. or feet of liquid needed to overcome the resistance to the flow in the pipe and fittings.

■ **Suction Lift:** Exists when the source of supply is below the center line of the pump.

■ **Suction Head:** Exists when the source of supply is above the center line of the pump.

■ **Static Suction Lift:** The vertical distance from the center line of the pump down to the free level of the liquid source.

■ **Static Suction Head:** The vertical distance from the center line of the pump up to the free level of the liquid source.

■ **Static Discharge Head:** The vertical elevation from the center line of the pump to the point of free discharge.

■ **Dynamic Suction Lift:** Includes static suction lift, friction head loss and velocity head.

■ **Dynamic Suction Head:** Includes static suction head minus friction head minus velocity head.

■ **Dynamic Discharge Head:** Includes static discharge head plus friction head plus velocity head.

■ **Total Dynamic Head:** Includes the dynamic discharge head plus dynamic suction lift or minus dynamic suction head.

■ **Velocity Head:** The head needed to accelerate the liquid. Knowing the velocity of the liquid, the velocity head loss can be calculated by a simple formula $Head = V^2/2g$ in which g is acceleration due to gravity or 32.16 ft./sec. Although the velocity head loss is a factor in figuring the dynamic heads, the value is usually small and in most cases negligible. See table.

BASIC FORMULAS AND SYMBOLS

Formulas

$$GPM = \frac{Lb./Hr.}{500 \times Sp. Gr.}$$

$$H = \frac{2.31 \times psi}{Sp. Gr.}$$

$$H = \frac{1.134 \times In. Hg.}{Sp. Gr.}$$

$$H_v = \frac{V^2}{2g} = 0.155 V^2$$

$$V = \frac{GPM \times 0.321}{A} = \frac{GPM \times 0.409}{(I.D.)^2}$$

$$BHP = \frac{GPM \times H \times Sp. Gr.}{3960 \times Eff.}$$

$$Eff. = \frac{GPM \times H \times Sp. Gr.}{3960 \times BHP}$$

$$N_s = \frac{N \sqrt{GPM}}{H^{3/4}}$$

$$H = \frac{V^2}{2g}$$

Symbols

- GPM = gallons per minute
- Lb. = pounds
- Hr. = hour
- Sp. Gr. = specific gravity
- H = head in feet
- psi = pounds per square inch
- In. Hg. = inches of mercury
- h_v = velocity head in feet
- V = velocity in feet per second
- g = 32.16 ft./sec.² (acceleration of gravity)

- A = area in square inches (πr²) (for a circle or pipe)
- ID = inside diameter in inches
- BHP = brake horsepower
- Eff. = pump efficiency expressed as a decimal
- N_s = specific speed
- N = speed in revolutions per minute
- D = impeller in inches

Approximate Cost of Operating Electric Motors

Motor HP	*Average kilowatts input or cost based on 1 cent per kilowatt hour		Motor HP	*Av. kw input or cost per hr. based on 1 cent per kw hour
	1 Phase	3 Phase		3 Phase
1/3	.408		20	16.9
1/2	.535	.520	25	20.8
3/4	.760	.768	30	26.0
1	1.00	.960	40	33.2
1 1/2	1.50	1.41	50	41.3
2	2.00	1.82	60	49.5
3	2.95	2.70	75	61.5
5	4.65	4.50	100	81.5
7 1/2	6.90	6.75	125	102
10	9.30	9.00	150	122
			200	162

BASIC FORMULAS AND SYMBOLS

Temperature conversion

DEG. C = (DEG. F – 32) x .555

DEG. F = (DEG. C x 1.8) + 32

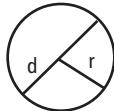

CIRCLE

Area of a Circle

A = area; C = circumference.

D = diameter

A = π r²; π = 3.14

r = radius

C = 2π r

Water Horsepower = $\frac{\text{GPM} \times 8.33 \times \text{Head}}{33000} = \frac{\text{GPM} \times \text{Head}}{3960}$

Where:

GPM = Gallons per Minute

8.33 = Pounds of water per gallon

33000 = Ft. Lbs. per minute in one horsepower

Head = Difference in energy head in feet (field head).

Laboratory BHP = $\frac{\text{Head} \times \text{GPM} \times \text{Sp. Gr.}}{3960 \times \text{Eff.}}$

Field BHP = Laboratory BHP + Shaft Loss

Total BHP = Field BHP + Thrust Bearing Loss

Where:

GPM = Gallons per Minute

Head = Lab. Head (including column loss)

Eff. = Lab. Eff. of Pump Bowls

Shaft Loss = HP loss due to mechanical friction of lineshaft bearings

Thrust Bearing Loss = HP Loss in driver thrust bearings

(See (1) below under Misc.)

Input Horsepower = $\frac{\text{Total BHP}}{\text{Motor Eff.}}$

Motor Eff. from Motor mfg. (as a decimal)

Field Efficiency = $\frac{\text{Water Horsepower}}{\text{Total BHP}}$

Water HP as determined above
Total BHP as determined above

Overall Plant Efficiency = $\frac{\text{Water Horsepower}}{\text{Input Horsepower}}$

(See (2) below under Misc.)
Water HP as determined above
Input HP as determined above

Electrical

Input Horsepower = $\frac{\text{BHP}}{\text{Mot. Eff.}} = \frac{4.826 \times \text{K} \times \text{M} \times \text{R}}{\text{T}} = \frac{1.732 \times \text{E} \times \text{I} \times \text{PF}}{746}$

BHP = Brake Horsepower as determined above

Mot. Eff. = Rated Motor Efficiency

K = Power Company Meter Constant

M = Power Company Meter Multiplier, or Ratio of Current and Potential Transformers connected with meter

R = Revolutions of meter disk

T = Time in Sec. for R

E = Voltage per Leg applied to motor

I = Amperes per Leg applied to motor

PF = Power factor of motor

1.732 = Factor for 3-phase motors. This reduces to 1 for single phase motors

Kilowatt input to Motor = $.746 \times \text{I.H.P.} = \frac{1.732 \times \text{E} \times \text{I} \times \text{PF}}{1000}$

KW-Hrs. Per 1000 Gallons of Cold Water Pumped Per Hour = $\frac{\text{HD in ft.} \times 0.00315}{\text{Pump Eff.} \times \text{Mot. Eff.}}$

Miscellaneous

(1) **Thrust Bearing Loss** = .0075 HP per 100 RPM per 1000 lbs. thrust.*
(2) **Overall Plant Efficiency** sometimes referred to as "Wire to Water" Efficiency
***Thrust (in lbs.)** = (thrust constant (k) laboratory head) + (setting in feet x shaft wt. per ft.)
Note: Obtain thrust constant from curve sheets

Discharge Head (in feet of fluid pumped) = $\frac{\text{Discharge Pressure (psi)} \times 2.31}{\text{Sp. Gr. of Fluid Pumped}}$

Goolds Pumps



<p>The affinity laws express the mathematical relationship between several variables involved in pump performance. They apply to all types of centrifugal and axial flow pumps. They are as follows:</p> <p>Q = Capacity, GPM H = Total Head, Feet BHP = Brake Horsepower N = Pump Speed, RPM D = Impeller Diameter (in.)</p>	<p>Use equations 1 through 3 when speed changes and impeller diameter remains constant</p> <ol style="list-style-type: none"> $\frac{Q_1}{Q_2} = \frac{N_1}{N_2}$ $\frac{H_1}{H_2} = \left(\frac{N_1}{N_2}\right)^2$ $\frac{BHP_1}{BHP_2} = \left(\frac{N_1}{N_2}\right)^3$ 	<p>Use equations 4 through 6 with impeller diameter changes and speed remains constant</p> <ol style="list-style-type: none"> $\frac{Q_1}{Q_2} = \frac{D_1}{D_2}$ $\frac{H_1}{H_2} = \left(\frac{D_1}{D_2}\right)^2$ $\frac{BHP_1}{BHP_2} = \left(\frac{D_1}{D_2}\right)^3$
---	---	---

To illustrate the use of these laws, let's look at a particular point (1) on a pump curve (figure 1). The diameter of the impeller for this curve is 6 inches. We will determine by the use of the Affinity Laws what happens to this point if we trim the impeller to 5 inches.

From the 6 inch diameter curve we obtain the following information:

- D₁ = 6" Dia. D₂ = 5" Dia.
- Q₁ = 200 GPM Q₂ = To be determined
- H₁ = 100 Ft. H₂ = To be determined
- BHP₁ = 7.5 HP BHP₂ = To be determined

The equations 4 through 6 above with speed (N) held constant will be used and rearranged to solve for the following:

Equation 4 $Q_2 = \frac{D_2}{D_1} \times Q_1$

Equation 5 $H_2 = \left(\frac{D_2}{D_1}\right)^2 \times H_1$

Equation 6 $BHP_2 = \left(\frac{D_2}{D_1}\right)^3 \times BHP_1$

The 6 inch information is put into the formulas and the new 5 inch diameter point is calculated:

$Q_2 = 5" \text{ dia.} \times 200 \text{ GPM} = 167 \text{ GPM}$
6" dia.

$H_2 = \left(\frac{5" \text{ dia.}}{6" \text{ dia.}}\right)^2 \times 100 \text{ Ft.} = 69 \text{ Ft.}$

$BHP_2 = \left(\frac{5" \text{ dia.}}{6" \text{ dia.}}\right)^3 \times 7.5 \text{ BHP} = 4.3 \text{ BHP}$

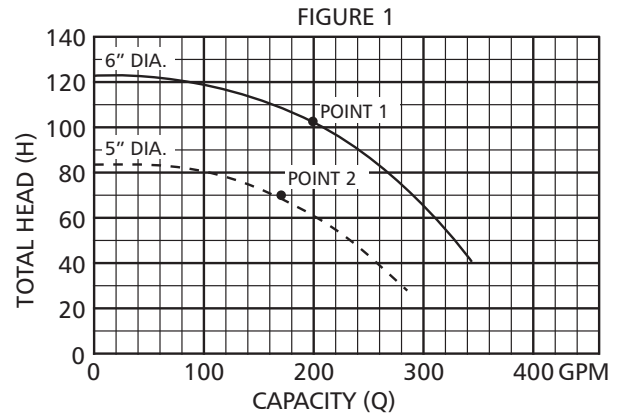

FIGURE 1
The 5 inch diameter Head/Capacity performance point can be plotted on the graph (figure 1; point 2). By taking additional Head/Capacity points on the 6" diameter curve line and using this procedure, a new Head/Capacity curve line can be produced for the 5 inch diameter impeller.

This same procedure and equations 1 through 3 can be used when pump speed changes and the impeller diameter remains constant.

Calculating impeller trim using Affinity Laws:

Example:

Assume a requirement of 225 GPM at 160' of Head (point 2, figure 2). Note this point falls between 2 existing curve lines with standard impeller diameters. To determine the trimmed impeller diameter to meet our requirement, draw a line from the required point (point 2) perpendicular to an existing curve line (point 1). Notice point 1 has an impeller diameter (D₁) of 6 3/4" and produces 230 GPM (Q₁) at 172' TDH (H₁).

Applying Affinity Law 5 to solve for our new impeller diameter (D₂).

Point 1 (Known)

- D₁ = 6 3/4" Dia. Impeller
- H₁ = 172' TDH
- Q₁ = 230 GPM

Point 2 (Unknown)

- D₂ = Unknown
- H₂ = 160' TDH
- Q₂ = 225 GPM

Rearranging law 5 to solve for D₂:

$$D_2 = D_1 \times \sqrt{\frac{H_2}{H_1}}$$

$$D_2 = 6.75 \times \sqrt{\frac{160}{172}}$$

$$D_2 = 6.55 = 6 \frac{9}{16}''$$

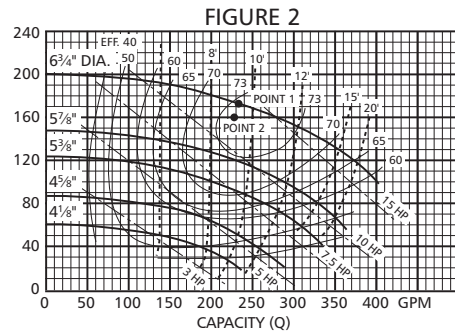

Determine that the new impeller will meet the required capacity:

Rearranging law 4 to solve for Q₂:

$Q_2 = \frac{D_2}{D_1} \times Q_1 = \frac{6.55}{6.75} \times 230 = 223$

DECIMAL AND MILLIMETER EQUIVALENTS OF FRACTION

Inches		Millimeters	Inches		Millimeters
Fractions	Decimals		Fractions	Decimals	
1/64	.015625	.397	33/64	.515625	13.097
1/32	.03125	.794	17/32	.53125	13.494
3/64	.046875	1.191	35/64	.546875	13.891
1/16	.0625	1.588	9/16	.5625	14.288
5/64	.078125	1.984	37/64	.578125	14.684
3/32	.09375	2.381	19/32	.59375	15.081
7/64	.109375	2.778	39/64	.609375	15.487
1/8	.125	3.175	5/8	.625	15.875
9/64	.140625	3.572	41/64	.640625	16.272
5/32	.15625	3.969	21/32	.65625	16.669
11/64	.171875	4.366	43/64	.671875	17.066
3/16	.1875	4.763	11/16	.6875	17.463
13/64	.203125	5.159	45/64	.703125	17.859
7/32	.21875	5.556	23/32	.71875	18.256
15/64	.234375	5.953	47/64	.734375	18.653
1/4	.250	6.350	3/4	.750	19.050
17/64	.265625	6.747	49/64	.765625	19.447
9/32	.28125	7.144	25/32	.78125	19.844
19/64	.296875	7.541	51/64	.796875	20.241
5/16	.3125	7.938	13/16	.8125	20.638
21/64	.328125	8.334	53/64	.828125	21.034
11/32	.34375	8.731	27/32	.84375	21.431
23/64	.359375	9.128	55/64	.859375	21.828
3/8	.375	9.525	7/8	.875	22.225
25/64	.390625	9.922	57/64	.890625	22.622
13/32	.40625	10.319	29/32	.90625	23.019
27/64	.421875	10.716	59/64	.921875	23.416
7/16	.4375	11.113	15/16	.9375	23.813
29/64	.453125	11.509	61/64	.953125	24.209
15/32	.46875	11.906	31/32	.96875	24.606
31/64	.484375	12.303	63/64	.984375	25.003
1/2	.500	12.700	1	1.000	25.400

ATMOSPHERIC PRESSURE, BAROMETER READING AND BOILING POINT OF WATER AT VARIOUS ALTITUDES

Altitude		Barometer Reading		Atmos. Press.		Boiling Pt. of Water °F
Feet	Meters	In. Hg.	Mm. Hg.	Psia	Ft. Water	
- 1000	- 304.8	31.0	788	15.2	35.2	213.8
- 500	- 152.4	30.5	775	15.0	34.6	212.9
0	0.0	29.9	760	14.7	33.9	212.0
+ 500	+ 152.4	29.4	747	14.4	33.3	211.1
+ 1000	304.8	28.9	734	14.2	32.8	210.2
1500	457.2	28.3	719	13.9	32.1	209.3
2000	609.6	27.8	706	13.7	31.5	208.4
2500	762.0	27.3	694	13.4	31.0	207.4
3000	914.4	26.8	681	13.2	30.4	206.5
3500	1066.8	26.3	668	12.9	29.8	205.6
4000	1219.2	25.8	655	12.7	29.2	204.7
4500	1371.6	25.4	645	12.4	28.8	203.8
5000	1524.0	24.9	633	12.2	28.2	202.9
5500	1676.4	24.4	620	12.0	27.6	201.9
6000	1828.8	24.0	610	11.8	27.2	201.0
6500	1981.2	23.5	597	11.5	26.7	200.1
7000	2133.6	23.1	587	11.3	26.2	199.2
7500	2286.0	22.7	577	11.1	25.7	198.3
8000	2438.4	22.2	564	10.9	25.2	197.4
8500	2590.8	21.8	554	10.7	24.7	196.5
9000	2743.2	21.4	544	10.5	24.3	195.5
9500	2895.6	21.0	533	10.3	23.8	194.6
10000	3048.0	20.6	523	10.1	23.4	193.7
15000	4572.0	16.9	429	8.3	19.2	184.0

HEAD AND PRESSURE EQUIVALENTS

1. Feet Head of Water and Equivalent Pressures
To change head in feet to pressure in pounds, multiply by .434

Feet Head	Pounds per Sq. In.	Feet Head	Pounds per Sq. In.	Feet Head	Pounds per Sq. In.	Feet Head	Pounds per Sq. In.
1	.43	30	12.99	140	60.63	300	129.93
2	.87	40	17.32	150	64.96	325	140.75
3	1.30	50	21.65	160	69.29	350	151.58
4	1.73	60	25.99	170	73.63	400	173.24
5	2.17	70	30.32	180	77.96	500	216.55
6	2.60	80	34.65	190	82.29	600	259.85
7	3.03	90	38.98	200	86.62	700	303.16
8	3.46	100	43.31	225	97.45	800	346.47
9	3.90	110	47.64	250	108.27	900	389.78
10	4.33	120	51.97	275	119.10	1000	433.09
20	8.66	130	56.30	-	-	-	-

2. Pressure and Equivalent Feet Head of Water
To change pounds pressure to feet head, multiply by 2.3

Pounds per Sq. In.	Feet Head	Pounds per Sq. In.	Feet Head	Pounds per Sq. In.	Feet Head	Pounds per Sq. In.	Feet Head
1	2.31	20	46.18	120	277.07	225	519.51
2	4.62	25	57.72	125	288.62	250	577.24
3	6.93	30	69.27	130	300.16	275	634.97
4	9.24	40	92.36	140	323.25	300	692.69
5	11.54	50	115.45	150	346.34	325	750.41
6	13.85	60	138.54	160	369.43	350	808.13
7	16.16	70	161.63	170	392.52	375	865.85
8	18.47	80	184.72	180	415.61	400	923.57
9	20.78	90	207.81	190	438.70	500	1154.48
10	23.09	100	230.90	200	461.78	1000	2309.00
15	34.63	110	253.98	-	-	-	-

CONVERSION CHARTS

English measures – unless otherwise designated, are those used in the United States.

Gallon – designates the U.S. gallon. To convert into the Imperial gallon, multiply the U.S. gallon by 0.83267. Likewise, the word ton designates a short ton, 2,000 pounds.

Properties of water – it freezes at 32°F, and is at its maximum density at 39.2°F. In the multipliers using the properties of water, calculations are based on water at 39.2°F in a vacuum, weighing 62.427 pounds per cubic foot, or 8.345 pounds per U.S. gallon.

Multiply	By	To Obtain
Acres	43,560	Square feet
Acres	4047	Square meters
Acres	1.562 x 10 ³	Square miles
Acres	4840	Square yards
Atmospheres	76.0	Cms. of mercury
Atmospheres	29.92	Inches of mercury
Atmospheres	33.90	Feet of water
Atmospheres	10,332	Kgs./sq. meter
Atmospheres	14.70	Lbs./sq. inch
Atmospheres	1.058	Tons/sq. ft.
Barrels-Oil	42	Gallons-Oil
Barrels-Beer	31	Gallons-Beer
Barrels-Whiskey	45	Gallons-Whiskey
Barrels/Day-Oil	0.02917	Gallons/Min-Oil
Bags or sacks-cement	94	Pounds-cement
Board feet	144 sq. in. x 1 in.	Cubic inches
B.T.U./min.	12.96	Foot-lbs./sec.
B.T.U./min.	0.02356	Horsepower
B.T.U./min.	0.01757	Kilowatts
B.T.U./min.	17.57	Watts
Centimeters	0.3937	Inches
Centimeters	0.01	Meters
Centimeters	10	Millimeters
Cubic feet	2.832 x 10 ⁴	Cubic cms.
Cubic feet	1728	Cubic inches
Cubic feet	0.02832	Cubic meters
Cubic feet	0.03704	Cubic yards
Cubic feet	7.48052	Gallons
Cubic feet	28.32	Liters
Cubic feet	59.84	Pints (liq.)
Cubic feet	29.92	Quarts (liq.)
Cubic feet/min.	472.0	Cubic cms./sec.
Cubic feet/min.	0.1247	Gallons/sec.
Cubic feet/min.	0.4719	Liters/sec.
Cubic feet/min.	62.43	Lbs. of water/min.
Cubic feet/sec.	0.646317	Millions gals./day
Cubic feet/sec.	448.831	Gallons/min.
Cubic inches	16.39	Cubic centimeters
Cubic inches	5.787 x 10 ⁻⁴	Cubic feet
Cubic inches	1.639 x 10 ⁻⁵	Cubic meters
Cubic inches	2.143 x 10 ⁻⁵	Cubic yards

Multiply	By	To Obtain
Cubic inches	4.329 x 10 ⁻³	Gallons
Cubic inches	1.639 x 10 ⁻²	Liters
Cubic inches	0.03463	Pints (liq.)
Cubic inches	0.01732	Quarts (liq.)
Cubic yards	764,544.86	Cubic centimeters
Cubic yards	27	Cubic feet
Cubic yards	46,656	Cubic inches
Cubic yards	0.7646	Cubic meters
Cubic yards	202.0	Gallons
Cubic yards	764.5	Liters
Cubic yards	1616	Pints (liq.)
Cubic yards	807.9	Quarts (liq.)
Cubic yards/min.	0.45	Cubic feet/sec.
Cubic yards/min.	3.366	Gallons/sec.
Cubic yards/min.	12.74	Liters/sec.
Fathoms	6	Feet
Feet	30.48	Centimeters
Feet	12	Inches
Feet	0.3048	Meters
Feet	1/3	Yards
Feet of water	0.0295	Atmospheres
Feet of water	0.8826	Inches of mercury
Feet of water	304.8	Kgs./sq. meter
Feet of water	62.43	Lbs./Sq. ft.
Feet of water	0.4335	Lbs./sq. inch
Feet/min.	0.5080	Centimeters/sec.
Feet/min.	0.01667	Feet/sec.
Feet/min.	0.01829	Kilometers/hr.
Feet/min.	0.3048	Meters/min.
Feet/min.	0.01136	Miles/hr.
Feet/sec.	30.48	Centimeters/sec.
Feet/sec.	1.097	Kilometers/hr.
Feet/sec.	0.5924	Knots
Feet/sec.	18.29	Meters/min.
Feet/sec.	0.6818	Miles/hr.
Feet/sec.	0.01136	Miles/min.
Feet/sec./sec.	30.48	Cms./sec./sec.
Feet/sec./sec.	0.3048	Meters/sec./sec.
Foot-pounds	1.286 x 10 ³	British Thermal Units
Foot-pounds	5.050 x 10 ⁷	Horsepower-hrs.
Foot-pounds	3.240 x 10 ⁴	Kilogram-calories

Goulds Pumps



ITT Industries

Multiply	By	To Obtain
Foot-pounds	0.1383	Kilogram-meters
Foot-pounds	3.766×10^7	Kilowatt-hours
Gallons	3785	Cubic centimeters
Gallons	0.1337	Cubic feet
Gallons	231	Cubic inches
Gallons	3.785×10^{-3}	Cubic meters
Gallons	4.951×10^{-3}	Cubic yards
Gallons	3.785	Liters
Gallons	8	Pints (liq.)
Gallons	4	Quarts (liq.)
Gallons-Imperial	1.20095	U.S. gallons
Gallons-U.S.	0.83267	Imperial gallons
Gallons water	8.345	Pounds of water
Gallons/min.	2.228×10^{-3}	Cubic feet/sec.
Gallons/min.	0.06308	Liters/sec.
Gallons/min.	8.0208	Cu. ft./hr.
Gallons/min.	.2271	Meters ³ /hr.
Grains/U.S. gal.	17.118	Parts/million
Grains/U.S. gal.	142.86	Lbs./million gal.
Grains/Imp. gal.	14.254	Parts/million
Grams	15.43	Grains
Grams	.001	Kilograms
Grams	1000	Milligrams
Grams	0.03527	Ounces
Grams	2.205×10^{-3}	Pounds
Horsepower	42.44	B.T.U./min.
Horsepower	33,000	Foot-lbs./min.
Horsepower	550	Foot-lbs./sec.
Horsepower	1.014	Horsepower (metric)
Horsepower	0.7457	Kilowatts
Horsepower	745.7	Watts
Horsepower (boiler)	33,493	B.T.U./hr.
Horsepower (boiler)	9.809	Kilowatts
Horsepower-hours	2546	B.T.U.
Horsepower-hours	1.98×10^6	Foot-lbs.
Horsepower-hours	2.737×10^5	Kilogram-meters
Horsepower-hours	0.7457	Kilowatt-hours
Inches	2.540	Centimeters
Inches of mercury	0.03342	Atmospheres
Inches of mercury	1.133	Feet of water
Inches of mercury	345.3	Kgs./sq. meter
Inches of mercury	70.73	Lbs./sq. ft.
Inches of mercury (32°F)	0.491	Lbs./sq. inch
Inches of water	0.002458	Atmospheres
Inches of water	0.07355	Inches of mercury
Inches of water	25.40	Kgs./sq. meter
Inches of water	0.578	Ounces/sq. inch
Inches of water	5.202	Lbs. sq. foot
Inches of water	0.03613	Lbs./sq. inch
Kilograms	2.205	Lbs.

Multiply	By	To Obtain
Kilograms	1.102×10^{-3}	Tons (short)
Kilograms	10^3	Grams
Kiloliters	10^3	Liters
Kilometers	10^5	Centimeters
Kilometers	3281	Feet
Kilometers	10^3	Meters
Kilometers	0.6214	Miles
Kilometers	1094	Yards
Kilometers/hr.	27.78	Centimeters/sec.
Kilometers/hr.	54.68	Feet/min.
Kilometers/hr.	0.9113	Feet/sec.
Kilometers/hr.	.5399	Knots
Kilometers/hr.	16.67	Meters/min.
Kilowatts	56.907	B.T.U./min.
Kilowatts	4.425×10^4	Foot-lbs./min.
Kilowatts	737.6	Foot-lbs./sec.
Kilowatts	1.341	Horsepower
Kilowatts	10^3	Watts
Kilowatt-hours	3414.4	B.T.U.
Kilowatt-hours	2.655×10^6	Foot-lbs.
Kilowatt-hours	1.341	Horsepower-hrs.
Kilowatt-hours	3.671×10^5	Kilogram-meters
Liters	10^3	Cubic centimeters
Liters	0.03531	Cubic feet
Liters	61.02	Cubic inches
Liters	10^{-3}	Cubic meters
Liters	1.308×10^{-3}	Cubic yards
Liters	0.2642	Gallons
Liters	2.113	Pints (liq.)
Liters	1.057	Quarts (liq.)
Liters/min.	5.886×10^{-4}	Cubic ft./sec.
Liters/min.	4.403×10^{-3}	Gals./sec.
Lumber Width (in.) x Thickness (in.) 12	Length (ft.)	Board feet
Meters	100	Centimeters
Meters	3.281	Feet
Meters	39.37	inches
Meters	10^{-3}	Kilometers
Meters	10^3	Millimeters
Meters	1.094	Yards
Miles	1.609×10^5	Centimeters
Miles	5280	Feet
Miles	1.609	Kilometers
Miles	1760	Yards
Miles/hr.	44.70	Centimeters/sec.
Miles/hr.	88	Feet/min.
Miles/hr.	1.467	Feet/sec.
Miles/hr.	1.609	Kilometers/hr.
Miles/hr.	0.8689	Knots

Goulds Pumps

ITT Industries

Multiply	By	To Obtain
Miles/hr.	26.82	Meters/min.
Miles/min.	2682	Centimeters/sec.
Miles/min.	88	Feet/sec.
Miles/min.	1.609	Kilometers/min.
Miles/min.	60	Miles/hr.
Ounces	16	Drams
Ounces	437.5	Grains
Ounces	0.0625	Pounds
Ounces	28.3495	Grams
Ounces	2.835×10^{-5}	Tons (metric)
Parts/million	0.0584	Grains/U.S. gal.
Parts/million	0.07015	Grains/Imp. gal.
Parts/million	8.345	Lbs./million gal.
Pounds	16	Ounces
Pounds	256	Drams
Pounds	7000	Grains
Pounds	0.0005	Tons (short)
Pounds	453.5924	Grams
Pounds of water	0.01602	Cubic feet
Pounds of water	27.68	Cubic inches
Pounds of water	0.1198	Gallons
Pounds of water/min.	2.670×10^{-4}	Cubic ft./sec.
Pounds/cubic foot	0.01602	Grams/cubic cm.
Pounds/cubic foot	16.02	Kgs./cubic meters
Pounds/cubic foot	5.787×10^{-4}	Lbs./cubic inch
Pounds/cubic inch	27.68	Grams/cubic cm.
Pounds/cubic inch	2.768×10^4	Kgs./cubic meter
Pounds/cubic inch	1728	Lbs./cubic foot
Pounds/foot	1.488	Kgs./meter
Pounds/inch	1152	Grams/cm.
Pounds/sq. foot	0.01602	Feet of water
Pounds/sq. foot	4.882	Kgs./sq. meter
Pounds/sq. foot	6.944×10^{-3}	Pounds/sq. inch
Pounds/sq. inch	0.06804	Atmospheres
PSI	2.307	Feet of water
PSI	2.036	Inches of mercury
PSI	703.1	Kgs./sq. meter
Quarts (dry)	67.20	Cubic inches
Quarts (liq.)	57.75	Cubic inches
Square feet	2.296×10^{-5}	Acres
Square feet	929.0	Square centimeters
Square feet	144	Square inches
Square feet	0.09290	Square meters
Square feet	3.587×10^{-4}	Square miles
Square feet	1/9	Square yards
$\frac{1}{\text{sq. ft./gal./min.}}$	8.0208	Overflow rate (ft./hr.)
Square inches	6.452	Square centimeters
Square inches	6.944×10^{-3}	Square feet
Square inches	645.2	Square millimeters

Multiply	By	To Obtain
Square kilometers	247.1	Acres
Square kilometers	10.76×10^6	Square feet
Square kilometers	10^6	Square meters
Square kilometers	0.3861	Square miles
Square kilometers	1.196×10^6	Square yards
Square meters	2.471×10^{-4}	Acres
Square meters	10.76	Square feet
Square meters	3.861×10^{-7}	Square miles
Square meters	1.196	Square yards
Square miles	640	Acres
Square miles	27.88×10^6	Square feet
Square miles	2.590	Square kilometers
Square miles	3.098×10^6	Square yards
Square yards	2.066×10^{-4}	Acres
Square yards	9	Square feet
Square yards	0.8361	Square meters
Square yards	3.228×10^{-7}	Square miles
Temp (°C)+273	1	Abs. temp. (°C)
Temp. (°C)+17.78	1.8	Temp. (°F)
Temp. (°F)+460	1	Abs. temp. (°F)
Temp. (°F)-32	5/9	Temp (°C)
Tons (metric)	10^3	Kilograms
Tons (metric)	2205	Pounds
Tons (short)	2000	Pounds
Tons (short)	32,000	Ounces
Tons (short)	907.1843	Kilograms
Tons (short)	0.89287	Tons (long)
Tons (short)	0.90718	Tons (metric)
Tons of water/24 hrs.	83.333	Pounds water/hr.
Tons of water/24 hrs.	0.16643	Gallons/min.
Tons of water/24 hrs.	1.3349	Cu. ft./hr.
Watts	0.05686	B.T.U./min.
Watts	44.25	Foot-lbs./min.
Watts	0.7376	Foot-lbs./sec.
Watts	1.341×10^{-3}	Horsepower
Watts	0.01434	Kg.-calories/min.
Watts	10^{-3}	Kilowatts
Watt-hours	3.414	B.T.U.
Watt-hours	2655	Foot-lbs.
Watt-hours	1.341×10^{-3}	Horsepower-hrs.
Watt-hours	0.8604	Kilogram-calories
Watt-hours	367.1	Kilogram-meters
Watt-hours	10^{-3}	Kilowatt-hours
Yards	91.44	Centimeters
Yards	3	Feet
Yards	36	Inches
Yards	0.9144	Meters

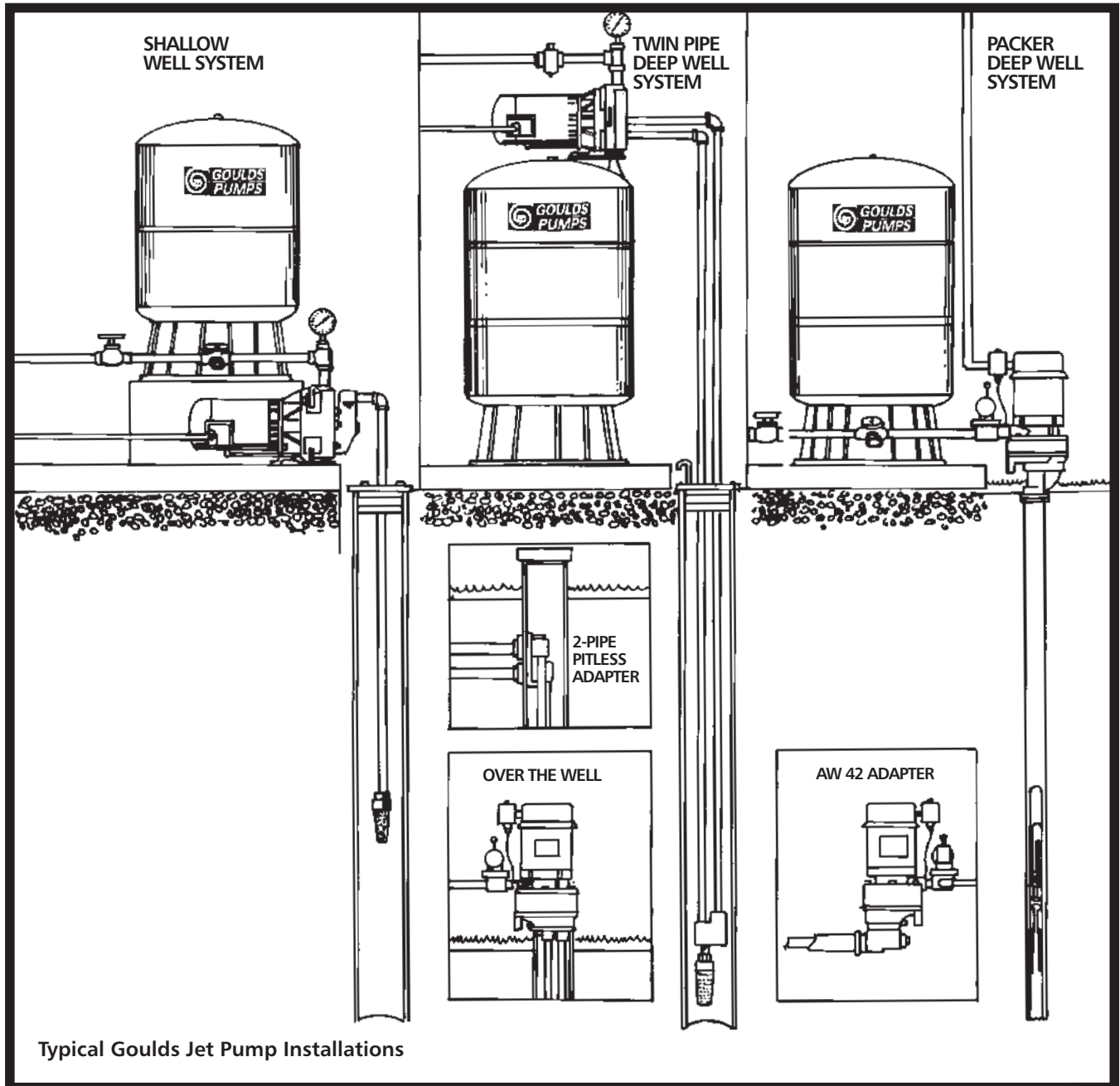

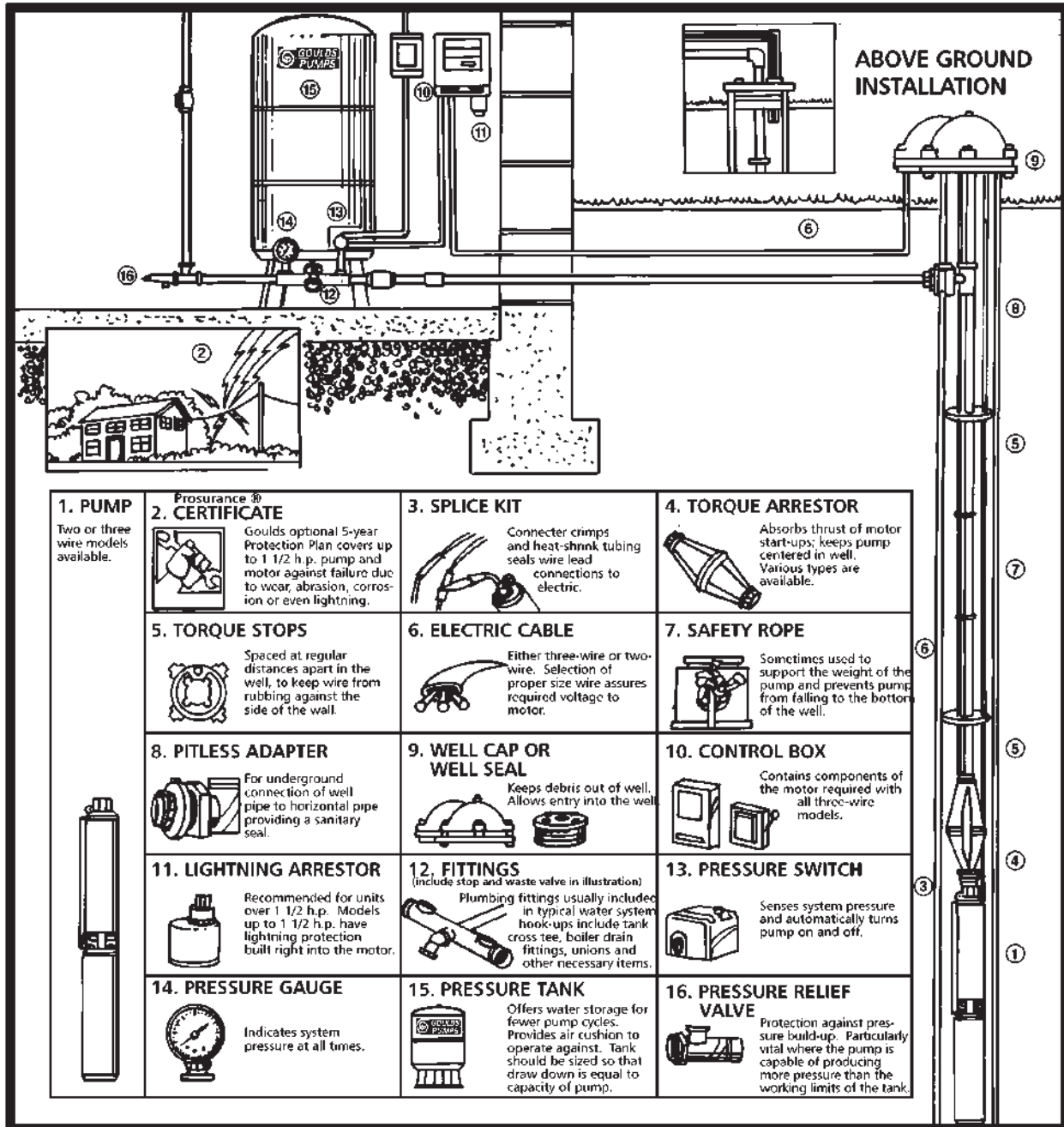

Typical Goulds Submersible Pump Installations

Goulds Pumps



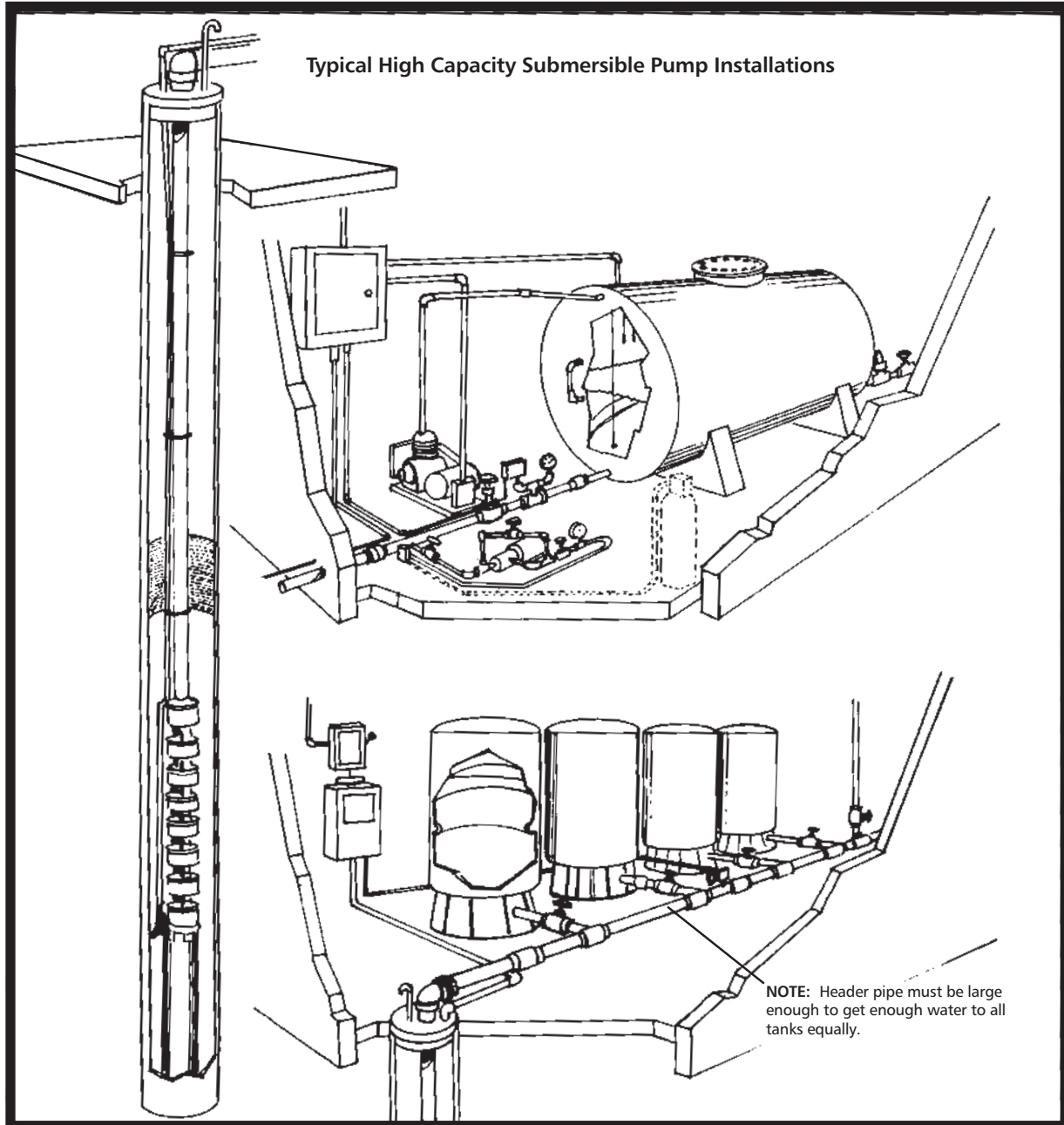

AUTOMATIC OPERATION

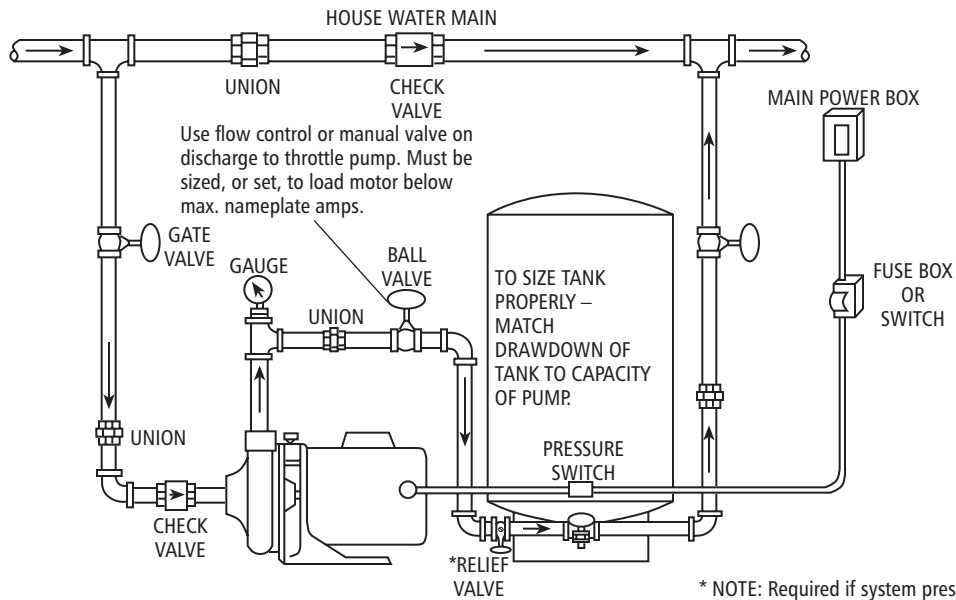

* NOTE: Required if system pressure can exceed 100 PSI.

MANUAL OPERATION

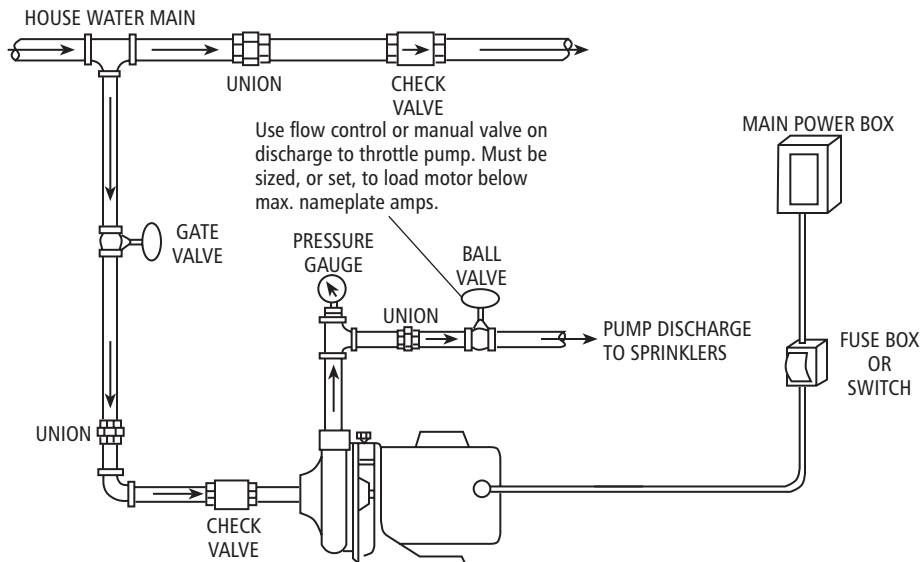

**AUTOMATIC OPERATION
JET PUMP - SHALLOW WELL OR CONVERTIBLE WITH INJECTOR**

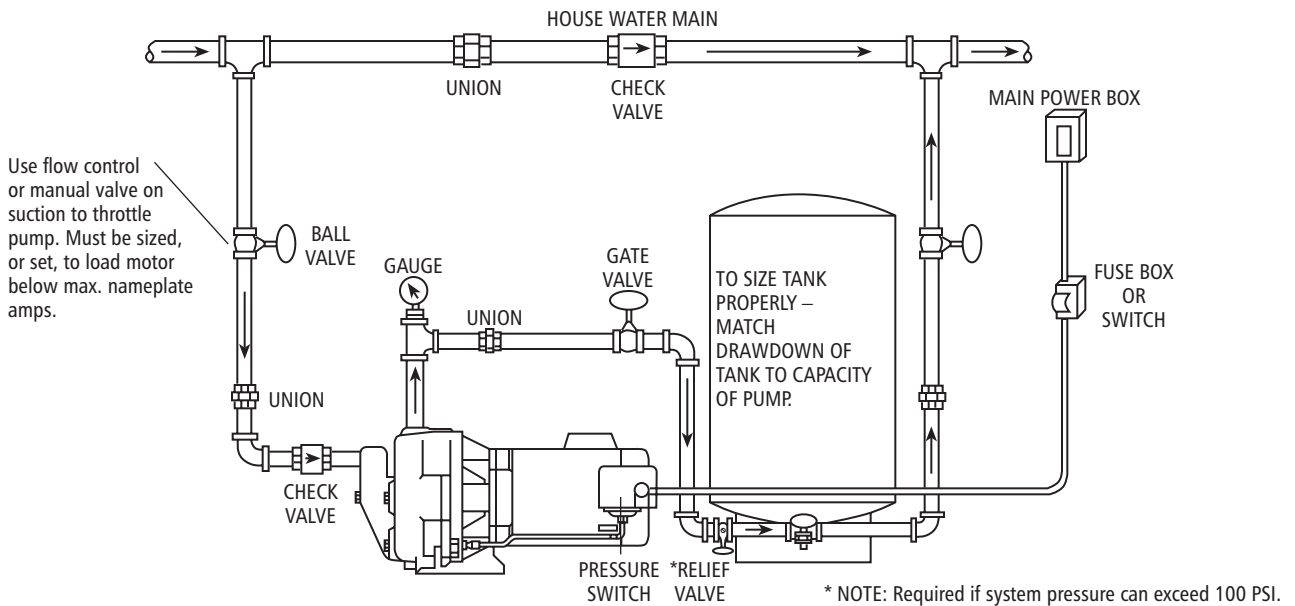

SIZING THE BOOSTER PUMP

Booster system pumps are sized the same as shallow well jet pumps with the exception being, we add the incoming city pressure to what the pump provides. The required flow is determined by the number of bathrooms or number of fixtures being used at any given time. City water is supplied under pressure, low incoming pressure is caused by undersized, crushed or severely corroded pipes or large elevation differences, such as a hill, between the city water line and the house.

Verify the incoming pressure with the water flowing to find the "dynamic suction pressure", static pressure is what you see with no water flowing. Use the dynamic suction pressure to calculate pump performance and selection. The J5S and the high pressure version, J5SH are very popular as booster pumps. The J5SH is a good choice for booster applications because of its narrow flow range and higher pressure capability. In the absence of performance data for 0' we use the 5' Total Suction Lift performance data. Add the incoming dynamic pressure to the pump's discharge pressure to find the total discharge pressure. Make a chart showing the flow, incoming dynamic pressure, pump discharge pressure and total discharge pressure for each job. It would look like this if using a J5SH pump with 15 PSI of incoming dynamic pressure:

Flow Rate GPM	Pump Discharge Pressure (PSI)	Incoming Dynamic Pressure (PSI)	Total Discharge Pressure (PSI)
11.5	20	15	35
11.3	30	15	45
11	40	15	55
7.7	50	15	65
4.8	60	15	75
0	83	15	98

STORAGE OF WATER IN VARIOUS SIZE PIPES

Pipe Size	Volume in Gallons per Foot	Pipe Size	Volume in Gallons per Foot
1¼	.06	6	1.4
1½	.09	8	2.6
2	.16	10	4.07
3	.36	12	5.87
4	.652		

MINIMUM FLOW TO MAINTAIN 2FT./SEC. *SCOURING VELOCITY IN VARIOUS PIPES

Pipe Size	Minimum GPM	Pipe Size	Minimum GPM
1¼	9	6	180
1½	13	8	325
2	21	10	500
3	46	12	700
4	80		

* Failure to maintain or exceed this velocity will result in clogged pipes. Based on schedule 40 nominal pipe.

STORAGE OF WATER IN VARIOUS SIZES OF WELLS

$$\frac{D^2}{24.5} = \text{Gals. of Storage per Foot}$$

Where: D = Inside diameter of well casing in inches

Examples:

2" Casing = .16 Gals. per ft. Storage	8" Casing = 2.6 Gals. per ft. Storage
3" Casing = .36 Gals. per ft. Storage	10" Casing = 4.07 Gals. per ft. Storage
4" Casing = .652 Gals. per ft. Storage	12" Casing = 5.87 Gals. per ft. Storage
5" Casing = 1.02 Gals. per ft. Storage	14" Casing = 7.99 Gals. per ft. Storage
6" Casing = 1.4 Gals. per ft. Storage	16" Casing = 10.44 Gals. per ft. Storage

Jet Pump Motor Data and Electrical Components

GOULDS PUMPS AND A.O. SMITH MOTOR DATA

GP Number	Where Used	A.O. Smith Number	HP	Volts	Phase	Service Factor	Max. Load Amps	Watts	Circuit Breaker
J04853	J05, HB705	C48J2DB11C3HF	½	115/230	1	1.6	10.8/5.4	880	25/15
J05853	JL07N, HSJ07, XSH07, HB	C48K2DB11A4HH	¾	115/230	1	1.5	14.8/7.4	1280	30/15
J06853	JL10N, HSJ10, SJ10, XSH10, HB	C48L2DB11A4HH	1	115/230	1	1.4	16.2/8.1	1440	30/20
J07858	HSJ15, SJ15, HB, XSH15	C48M2DB11A1HH	1½	115/230	1	1.3	20.0/10.0	1866	40/20
J08854	HSJ20, HSC20, XSH20	K48N2DB11A2HH	2	115/230	1	1.2	22.6/11.3	2100	25/15
② J09853	XSH30, GT30	C56P2U11A3HH	3	230	1	1.15	17.2	3280	30
② J04853L	J5(S), GB	C48A93A06	½	115/230	1	1.6	10.8/5.4	968	25/15
② J05853L	J7(S), GB, GT07, (H)SJ07, HSC07	C48A94A06	¾	115/230	1	1.5	14.8/7.4	1336	30/15
② J06853L	J10(S), GB, GT10, (H)SJ10, HSC10	C48A95A06	1	115/230	1	1.4	16.2/8.1	1592	30/20
② J07858L	J15(S), GB, GT15, HSJ15, HSC15	C48M2DC11A1	1½	115/230	1	1.3	21.4/10.7	1950	40/20
①② J08854L	HSJ20, GB, GT20, HSC20	K48A34A06	2	230	1	1.2	12.9	2100	25
SFJ04853	JB05	S48A90A06	½	115/230	1	1.6	9.4/4.7	900	20/10
SFJ05853	JB07	C48A77A06	¾	115/230	1	1.5	13.6/6.8	1160	25/15
SFJ06853	JB10	C48A78A06	1	115/230	1	1.4	15.8/7.9	1400	30/20
② SFJ04860	JRS5, JRD5, JB05	C48C04A06	½	115/230	1	1.6	12.6/6.3	990	25/15
② SFJ05860	JRS7, JRD7, JB07	C48C05A06	¾	115/230	1	1.5	14.8/7.4	1200	30/15
② SFJ06860	JRS10, JRD10, JB10	C48C06A06	1	115/230	1	1.4	16.2/8.1	1400	30/20

① Effective July, 1998, 230 V only. ② Current production motor

ELECTRICAL COMPONENTS

Goulds Pumps Motor Model	A.O. Smith Motor Model	Motor Overload with Leads			Run Capacitor and MFD	Start Capacitor MFD Rating	Switch⑤
		④ Old Number	③ New Number	T.I. Number			
J04853	C48J2DB11C3HF	614246 71		MET38ABN		610807 1: 124/148	629002 2
J05853	C48K2DB11A4HH	614246 20		CET63ABN		610807 2: 161/192	629002 2
J06853	C48L2DB11A4HH	614246 9		CET52ABN		610807 2: 161/192	629002 2
J07858	C48M2DB11A1HH	614246 79		CET38ABM		610807 2: 161/192	629002 2
J08854	K48N2DB11A2HH	611307 29		BRT44ABM	614529 4: 25	610807 1: 124/148	629002 2
J09853	C56P2U11A3HH	611106 22	611106 36	BRB2938		610807 32: 189/227	629002 2
J04853L	C48A93A06	614246 98	627121 43	MET39ABN-CL		610807 1:124/148	629002 2
J05853L	C48A94A06	614246 20	627121 38	CET63ABN		610807 2:161/192	629002 2
J06853L	C48A95A06	614246 9	627121 7	CET52ABN		610807 2:161/192	629002 2
J07858L	C48M2DC11A1HH	614246 153	627121 47	CET36WX		610807 2:161/192	629002 2
J08854L	K48A34A06	616861 10	627119 10	CET31ABN	623450 8: 30	610807 33: 64-77	629002 2
SFJ04853	S48A90A06	621863 1		MEJ38ABN		N/A	3945C91A01
SFJ05853	C48A77A06	621863 4		CET55ABN		610807 2: 161/192	3945C91A01
SFJ06853	C48A78A06	621863 5		CET49ABN		610807 2: 161/192	3945C91A01
SFJ04860	C48C04A06	614246 67	627121 48	MET36ABN		610807 2: 161/192	629002 2
SFJ05860	C48C05A06	614246 20	627121 38	CET63ABN		610807 2: 161/192	629002 2
SFJ06860	C48C06A06	614246 9	627121 7	CET52ABN		610807 2: 161/192	629002 2

③ These new overload part numbers are for use with the new plastic terminal board with the quick change voltage plug.

④ Use this suffix if your motor has the old style brown terminal board without quick change voltage plug.

⑤ 629002 2 replaces 614234 1, 2, and 6.

Goulds Pumps



**Jet Pump Motor Wiring
A.O. Smith Motors**

TERMINAL BOARD AND VOLTAGE CHANGE PLUG

A change has been made to use a new terminal board on the A.O. Smith two compartment motor models. This terminal board is used on both dual voltage and single voltage motors.

FEATURES

■ **Voltage Plug:** Dual voltage motors use a voltage plug that retains the terminals for the Black and Black Tracer leads. To change voltage, lift the black plug and align the arrow with the desired voltage on terminal board. See Figure 1 for an example of the dual voltage connection diagram.

■ **Screws with 1/4" drive:** The terminal screw accepts either a 1/4" nut driver or a slotted screw driver.

■ **Line Wire Connection:** The space under the screw will accept #16, #14, #12, #10, or #8 wire. The rib at the bottom edge of the screw allows the wire to be placed straight into the space under the screw. This rib retains the wire under the head of the screw and for #12, #10, or #8 wire it is not necessary to wrap the wire around the screw.

■ **1/2 HP wired 115 V, 3/4 HP and up wired 230 V at factory.**

■ **Quick Connect Terminals:** Each terminal has provision for 1/4" quick connect terminals in addition to the screw.

■ **Molded Plastic Material:** The terminal board is made from an extremely tough white plastic material with L1, L2, and A markings molded into the board.

■ **Lead Channel:** A channel adjacent to the conduit hole directs wiring to the top of the board.

■ **Governor Guard:** An integral backplate prevents leads from entering the area around the governor.

■ **Ground Guard:** To prevent the bare ground wire from touching the "live" L2 terminal, the ground wire must be placed above this guard.

VOLTAGE CHANGES ARE MADE INSIDE THE MOTOR COVER NOT IN THE PRESSURE SWITCH.

WARNING:

DISCONNECT POWER SOURCE BEFORE CHECKING. DO NOT MAKE ANY CHANGES WITH POWER ON.

**CAPACITOR START INDUCTION RUN – SINGLE SPEED
(NEW STYLE – AFTER APRIL, 1999)**

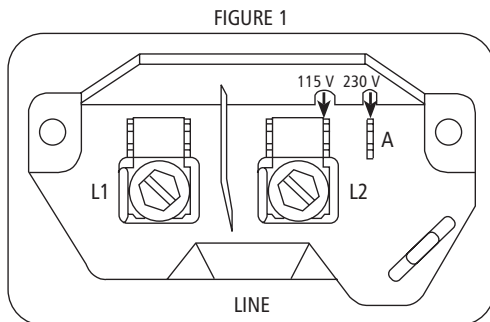

⊙ GRD ● Green (Ground)

Align black plug to 115 V or 230 V arrow.
1/2 HP wired 115 V, 3/4 HP and up wired 230 V at factory.

**CAPACITOR START INDUCTION RUN – SINGLE SPEED
(OLD STYLE – UP TO APRIL, 1999)**

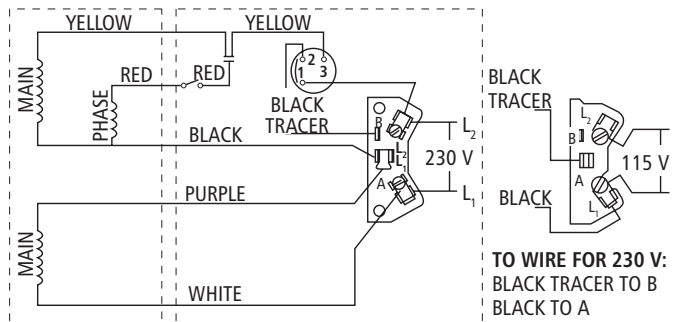

"Black Tracer" is a black and white wire

TO WIRE FOR 230 V:
BLACK TRACER TO B
BLACK TO A

TO WIRE FOR 115 V:
BLACK TRACER TO A
BLACK TO L₁

115/230 VOLTAGE CONNECTIONS

115 Voltage

Black — A
 Wht./Blk. Tracer — 1
 Line 1 — 2
 Line 2 — A
 (Blue — 3)

230 Voltage

Black — 1
 Wht./Blk. Tracer — B
 Line 1 — 2
 Line 2 — A
 (Blue — 3)

TO CHANGE MOTOR VOLTAGE:

Models without a Switch

115V to 230V

Move Wht./Blk. tracer to B
 Move Blk. to 1

230V to 115V

Move Blk. to A
 Move Wht./Blk. tracer to 1

Models with Voltage Change Switch

- Move toggle switch between 115V or 230V.

CONNECTIONS

115 VOLTAGE

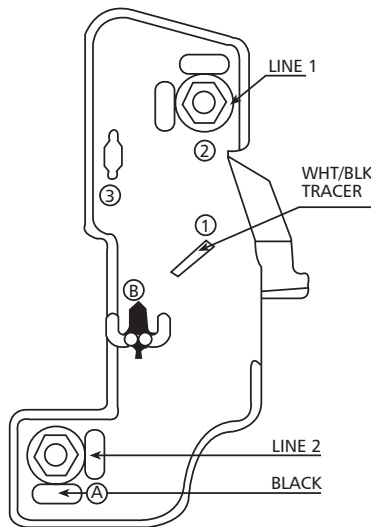

230 VOLTAGE

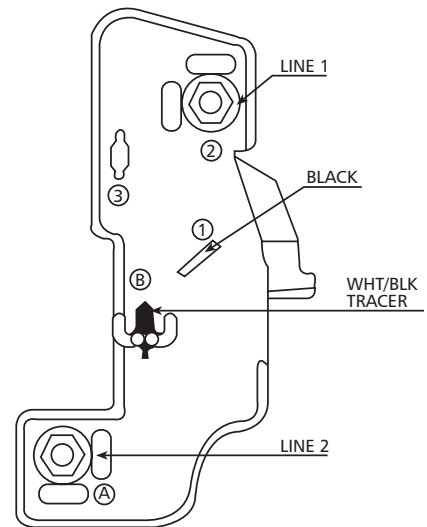

- A – has 2 male connectors and 1 screw connector
- 2 – has 2 male connectors and 1 screw connector
- B – is a dummy terminal used to hold the Wht./Blk. Tracer for 230V wiring

Motor is non-reversible CCW rotation shaft end.
 Supply connections, use wires sized on the basis of 60°C ampacity and rated minimum 90°C.

SQUARE "D" SWITCHES

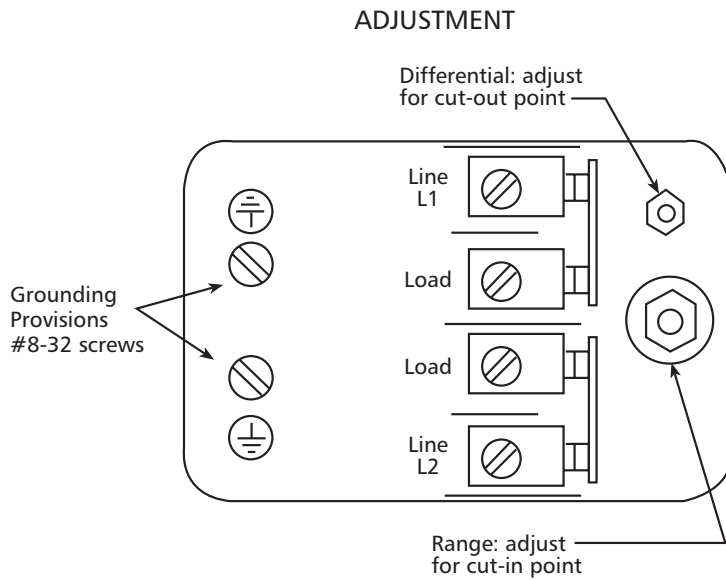

Adjust in proper sequence:

1. CUT-IN: Turn nut down for higher cut-in pressure, or up for lower cut-in.
2. CUT-OUT: Turn nut down for higher cut-out pressure, or up for lower cut-out.

CAUTION: TO AVOID DAMAGE, DO NOT EXCEED THE MAXIMUM ALLOWABLE SYSTEM PRESSURE. CHECK SWITCH OPERATION AFTER RESETTING.

FURNAS PRO CONTROL

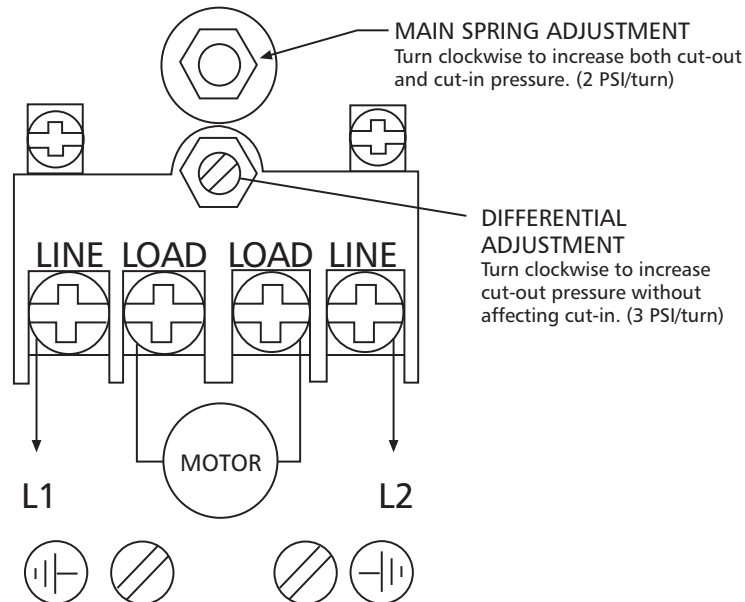

AWA501 / AWA502

FACTORY WIRED FOR 230 VAC.
FOR 115 VAC POWER SUPPLY,
WIRE HOT LEG TO (L1) AND
NEUTRAL TO (L2), JUMP
(L2) TO (N).

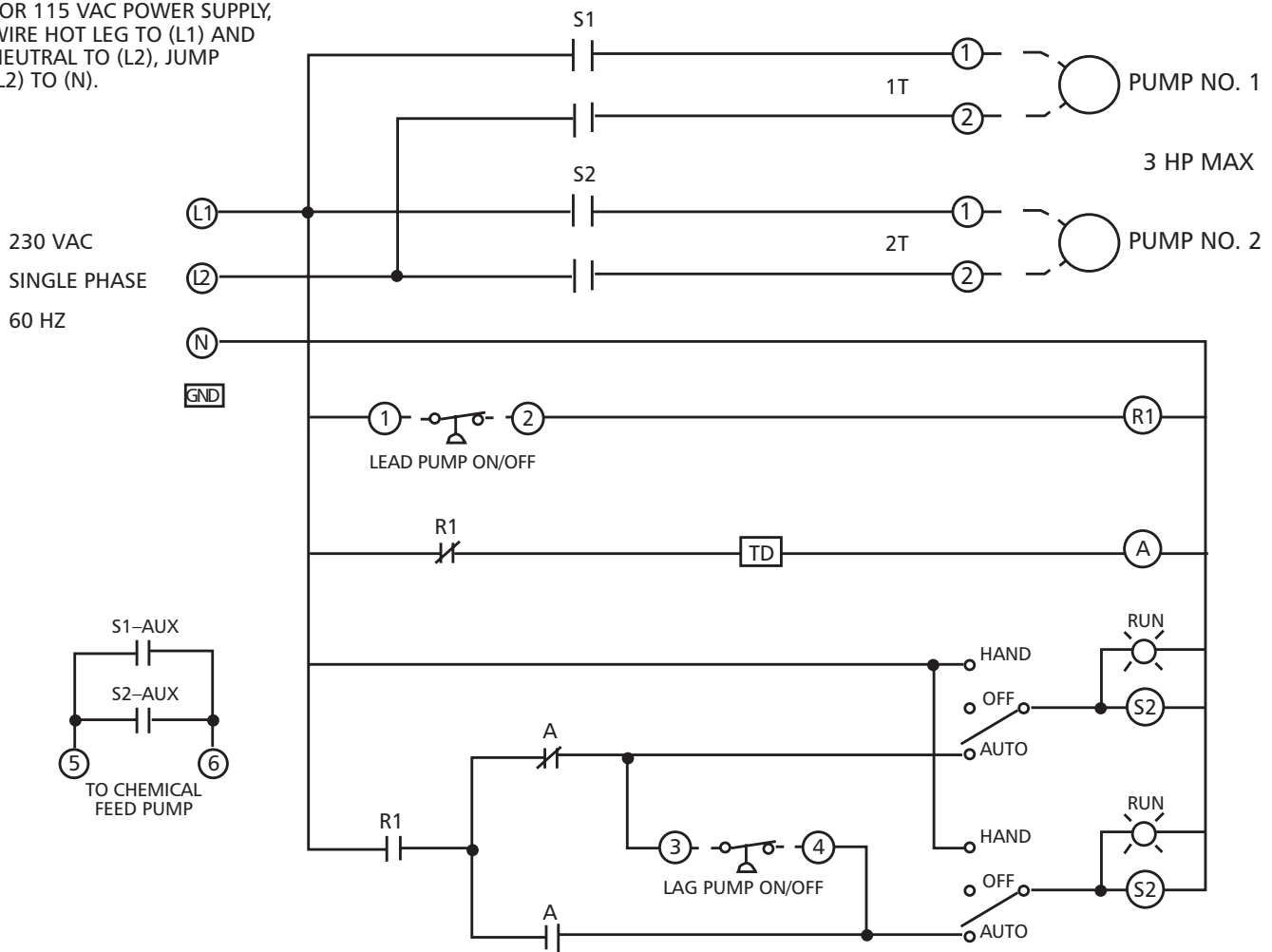

Power / Pump Connections: AWA501 / AWA502

POWER CONNECTION 230 VOLT AWA501, AWA502

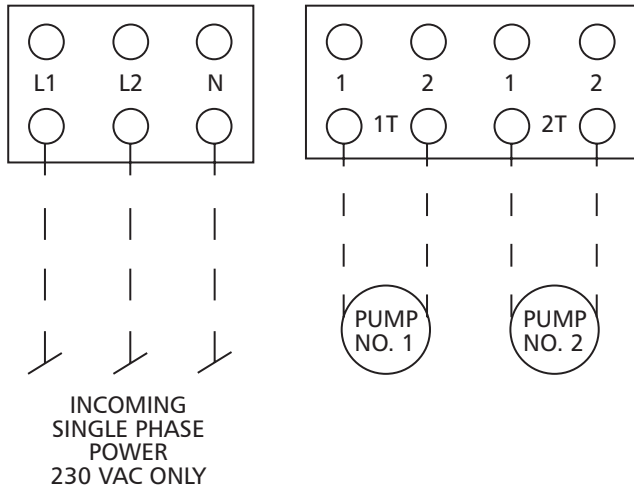

POWER CONNECTION AWA501 115 VOLT

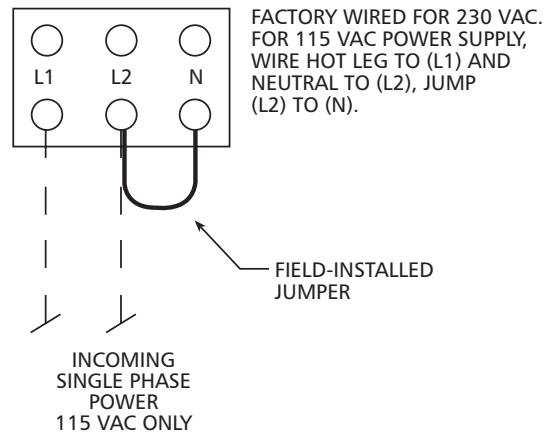

OPTIONAL FRANKLIN CONTROL BOX AND PUMPTEC WITH AWA501 AND AWA502 ONLY

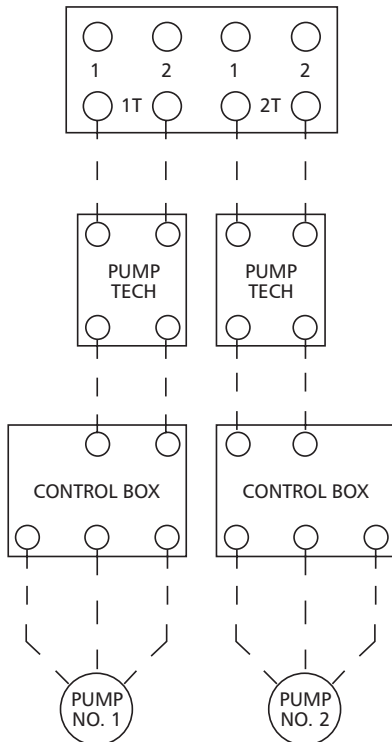

FIELD CONNECTIONS: AWA501, AWA502

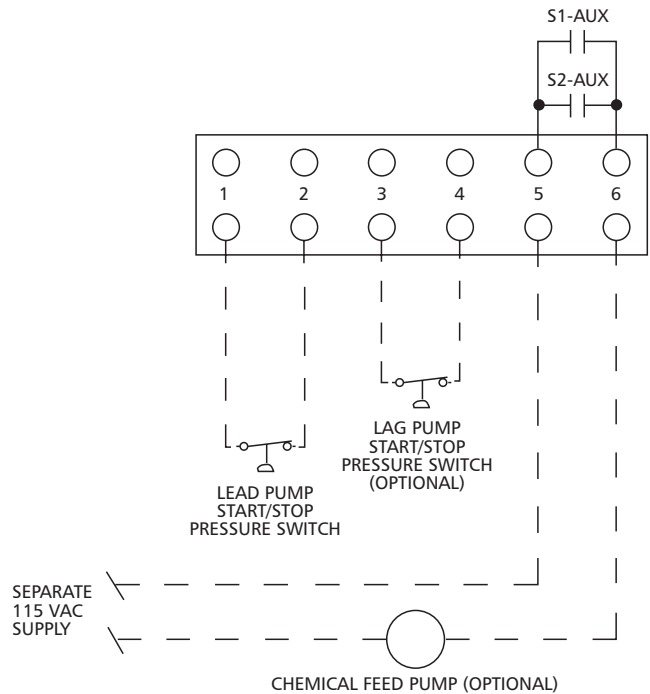

Goolds Pumps



COMPONENTS FOR A LOW YIELD WELL WITH A BOOSTER SYSTEM

- Submersible or jet pump to fill atmospheric tank
- Storage tank - usually at least a 500 gallon size
- Magnetic contactor - makes wiring simple and fast
- Normally closed float switch for automatic operation
- Booster pump - sub or jet to pressurize water from storage tank
- Pressure tank sized for 1 minute minimum pump cycle
- Pressure switch
- Check valve and gate valve between the open storage tank and jet pump, or a gate valve between the submersible and pressure tank

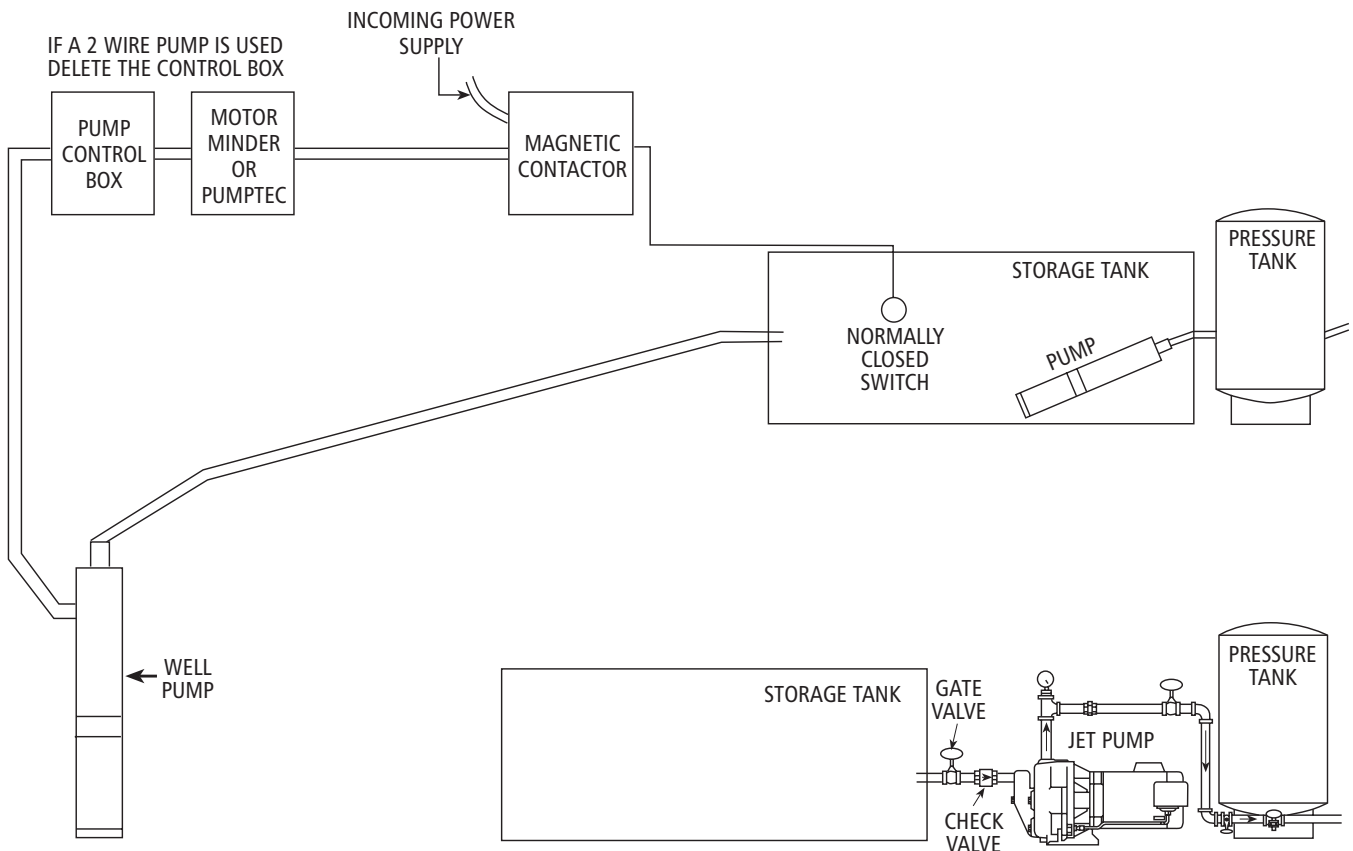

Goolds Pumps



Goulds Pumps is a brand of ITT Water Technology, Inc. – a subsidiary of ITT Industries, Inc.

Goulds Pumps and the ITT Engineered Blocks Symbol are registered trademarks and tradenames of ITT Industries.

Goulds Pumps



ITT Industries