

ITT

IM102

Residential Water

Goulds Pumps

Jet Pumps

Installation, Operation and Troubleshooting Manual

CLICK ANYWHERE on THIS PAGE to RETURN TO
WATER PUMP & TANK I/O & REPAIR MANUALS at
InspectApedia.com



 **GOULDS PUMPS**

Goulds Pumps is a brand of ITT Corporation.

www.goulds.com

Engineered for life

Table of Contents

<u>SUBJECT</u>	<u>PAGE</u>
Selecting the Correct Jet Pump System	3
Preparing for Installation	4
General Information - Piping.....	4
Shallow Well Installation	4
Deep Well Twin Pipe	5
Deep Well Packer System.....	5
Deep Well Discharge Piping.....	5
All Systems	6
Booster Systems.....	7
Seasonal Service	7
Recommended Deep Well Jet Assemblies and Control Valve Settings.....	8-9
Shallow Well Jet Assemblies For Convertible Pumps.....	9
Technical Data.....	10-11
Troubleshooting	12
Goolds Pumps Limited Warranty	12

SAFETY INSTRUCTIONS

TO AVOID SERIOUS OR FATAL PERSONAL INJURY OR MAJOR PROPERTY DAMAGE, READ AND FOLLOW ALL SAFETY INSTRUCTIONS IN MANUAL AND ON PUMP.

THIS MANUAL IS INTENDED TO ASSIST IN THE INSTALLATION AND OPERATION OF THIS UNIT AND MUST BE KEPT WITH THE PUMP.



This is a **SAFETY ALERT SYMBOL**. When you see this symbol on the pump or in the manual, look for one of the following signal words and be alert to the potential for personal injury or property damage.

⚠ DANGER Warns of hazards that **WILL** cause serious personal injury, death or major property damage.

⚠ WARNING Warns of hazards that **CAN** cause serious personal injury, death or major property damage.

⚠ CAUTION Warns of hazards that **CAN** cause personal injury or property damage.

NOTICE: INDICATES SPECIAL INSTRUCTIONS WHICH ARE VERY IMPORTANT AND MUST BE FOLLOWED.

THOROUGHLY REVIEW ALL INSTRUCTIONS AND WARNINGS PRIOR TO PERFORMING ANY WORK ON THIS PUMP.

MAINTAIN ALL SAFETY DECALS.

Important notice: Read safety instructions before proceeding with any wiring

⚠ WARNING All electrical work must be performed by a qualified technician. Always follow the National Electrical Code (NEC), or the Canadian Electrical Code, as well as all local, state and provincial codes. Code questions should be directed to your local electrical inspector. Failure to follow electrical codes and OSHA safety standards may result in personal injury or equipment damage. Failure to follow manufacturer's installation instructions may result in electrical shock, fire hazard, personal injury or death, damaged equipment, provide unsatisfactory performance, and may void manufacturer's warranty.

⚠ WARNING Standard units are not designed for use in hazardous liquids, or where flammable gases exist. Well must be vented per local codes. *See specific pump catalog bulletins or pump nameplate for all agency Listings.*

⚠ WARNING Disconnect and lockout electrical power before installing or servicing any electrical equipment. Many pumps are equipped with automatic thermal overload protection which may allow an overheated pump to restart unexpectedly.

⚠ WARNING Never over pressurize the tank, piping or system to a pressure higher than the tank's maximum pressure rating. This will damage the tank, voids the warranty and may create a serious hazard.

⚠ WARNING Protect tanks from excessive moisture and spray as it will cause the tank to rust and may create a hazard. See tank warning labels and IOM for more information.

SELECTING THE CORRECT JET PUMP SYSTEM

It is important to determine which jet pump system you need. A jet pump is a centrifugal pump with a jet (ejector) assembly. Goulds Pumps sells three types of jet pumps:

Shallow Well Jet Pumps with built-in jet assemblies for maximum lift of 25'. See Fig. 1

Convertible Jet Pumps can be used for Shallow wells (to 25'), with a bolt on shallow well adapter; or deep well (over 25') applications with a jet assembly in the well. See Fig. 1, 2 and 3.

Deep Well Jets should only be used on deep well (over 25') applications with the appropriate jet assembly. See Fig. 2 and 3

Use a shallow well pump or a convertible pump with a Shallow Well Adapter for wells with a maximum suction lift of 25'. This 25' includes actual vertical lift plus friction loss in the suction piping. Shallow well systems are identified by one (1) pipe going to the well, lake or river. They are good for city water booster systems and pumping from cisterns or tanks. See *Typical Installations, Figs. 1, 5 and 6.*

Deep well jet pumps are used for lifts greater than 25' and must have two pipes going to the well. There are two types of deep well jet assemblies, twin-pipe and packer systems. Deep well pumps come in both vertical and horizontal designs and in single and multi-stage models. See *Typical Installation Drawing, Fig. 2 and 3.*

Consult with your Professional Dealer or Distributor to select the best pump system for your application.

- Liquid temperature must not exceed 140° F (60°C).
- Protect unit from freezing

Typical Goulds Pumps Jet Pump Installations

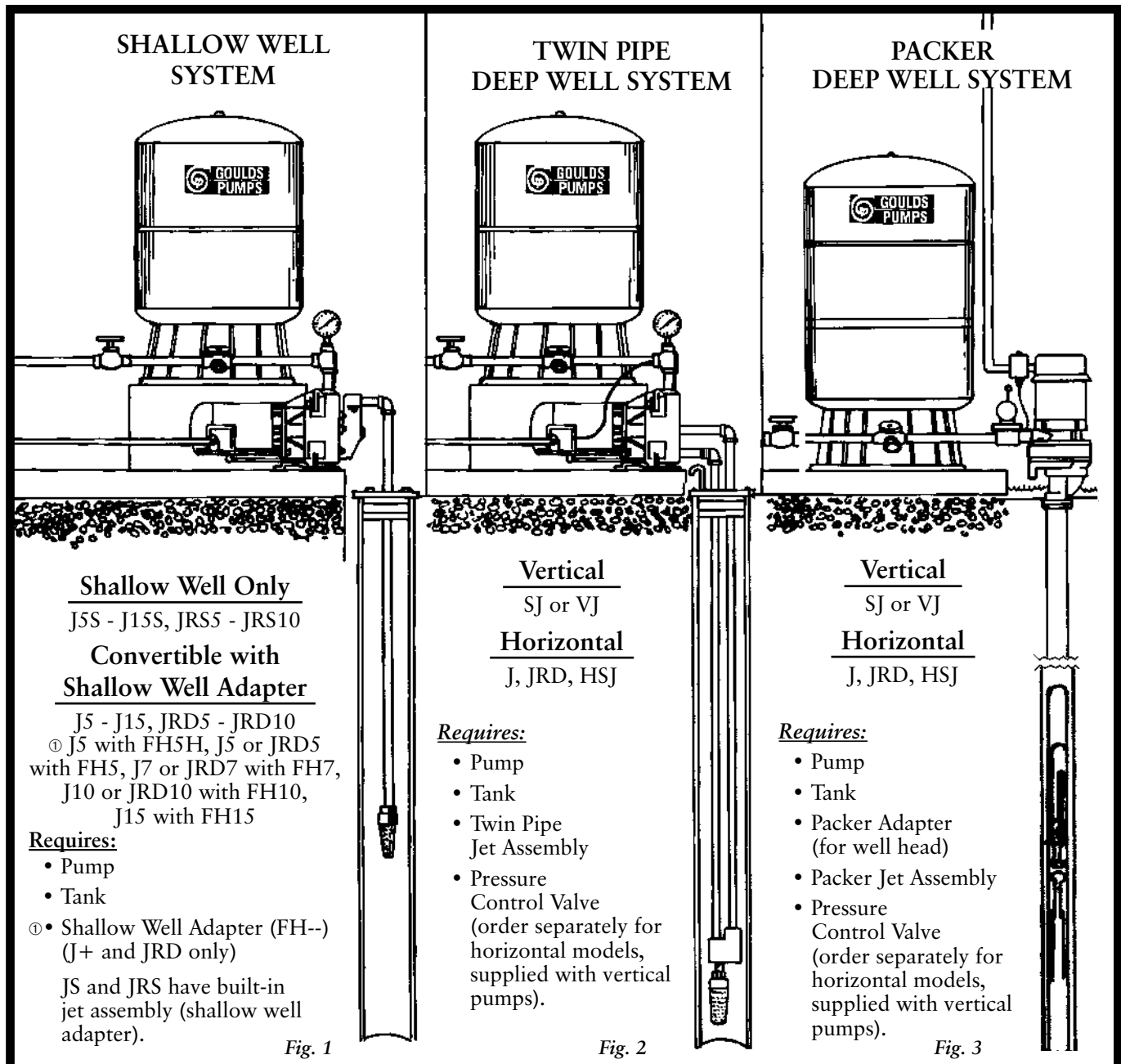

PREPARING FOR INSTALLATION

Inspect the pump and the motor assembly for shipping damage.

Insure that you have all of the parts required for a proper installation. See component lists for different system types. There are shallow well, convertible shallow well, convertible deep well – twin pipe, convertible deep well-packer, vertical deep well-twin pipe, vertical deep well-packer, and booster systems. *See Typical Installation Drawings and Chart 1.*

Check power supply voltage and select motor voltage. Goulds ½ hp Jet pumps are factory pre-wired for 115 volts while ¾ hp and larger are pre-wired for 230 volts. Motors from ½ hp to 1½ hp can operate on either 115 or 230 volts. The 2 hp motors operate only on 230 volts. *See Fig. 7.*

Select a site where the pump and tank will not freeze. The pump must be within 4' of the tank to prevent switch chatter. There should be no filters or valves, other than a wide open gate valve, between the pump and tank. Fluid temperature must not exceed 140° F (60°C).

GENERAL INFORMATION - PIPING

Always follow state and local plumbing codes. Goulds Pumps does not sell or specify pipe types or materials, consult with your pipe supplier to determine the best pipe for your installation. Pipes can be threaded, glued, soldered, or clamped to available fittings and adapters. If using poly pipe with barbed connectors we suggest you double clamp all fittings to prevent air leaks. It is very important to eliminate high spots and dips in suction piping as they will trap air and make the system very hard to prime. Never route the piping up above and then down to the pump suction. Suction piping should be either straight from the well to the pump or should slope upward to the pump. Pumps do not “hold” prime, piping systems and check valves do. Go to the specific section for your system type.

SHALLOW WELL INSTALLATION - *start here*

Suction Piping



The suction pipe should be at least as large as the pump suction, typically 1¼". Use of smaller pipe increases friction loss and increases effective suction lift. This will reduce flow and pressure. On offsets over 50' we recommend using pipe larger than the pump suction. This will reduce friction loss and improve performance.

Install a foot valve on the end of your drop pipe if the well is 2" or larger. Lower the drop pipe with foot valve into the well. It is best to keep it at least 5' off the bottom of a clean well. If you set it lower you increase the chance of pulling debris into the screen or into the pump.

On sand points or driven wells you can install an in-line check valve near the well head or at the pump and use the well casing as the suction pipe. The closer the check

valve is to the well the easier the system will prime. To prevent over pumping a low yield well you can throttle a jet pump using a ball valve in the suction line. You should install a compound pressure/vacuum gauge between the well and the valve. Do not throttle to more than 22" Hg (25' lift).

In areas where freezing occurs make the transition from vertical to horizontal below the frost line using a pitless adapter, consult with your plumbing supplier for pitless adapter information. In some areas they use a well seal and a 90° elbow.

We recommend not using filters on the suction side of a jet pump. Dirty filters increase the effective suction lift on the pump and can starve the pump of water. This will damage the impeller and diffuser which will affect performance.

Install Shallow Well Adapter On Convertible Pump Unpack the Goulds Pumps “Shallow Well Adapter”. Insure that the nozzle is installed in the adapter. Screw the venturi (long black tube) into the adapter. Install the gasket and bolt the adapter to the front of the pump using the four bolts provided. Tighten the bolts evenly to insure proper sealing and alignment of the venturi to the impeller. Do not over tighten the bolts. *See Chart 2.*

Shallow Well Pump – jet is built-in, proceed to next step.

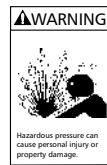

Attach Suction Piping To Pump

Install a barbed adapter into the 1¼" pump suction if using poly pipe and double clamp the fitting.

OR

Thread a pipe nipple and union into the suction port to make a threaded pipe connection. Make sure the union is clean and well seated. Any air leak will ruin performance and the pump will not make pressure!

Discharge Piping

Install a tee or cross tee in the pump discharge. (They are not supplied with the pump!) Install a pipe plug or a pressure gauge into a reducer bushing in the top port of the tee. This will be used as the priming port.

Cross Tee - the discharge line to the home attaches to one port and the tank attaches to the other. This is called an Off-Line Tank installation.

Tee - you can use one line to supply the house with the tank tee installed off the line. This is called an On-Line Tank Installation and is most common.

Note: Goulds Pumps HydroPro Water System tanks are shipped with a tank installation guide. Please refer to it for more detailed tank instructions.

Do not place valves or filters between the pump and tank, other than a fully open gate valve or “full port” ball valve. The most common ball valves are not full port! Most valves and filters will create excessive friction loss and cause “switch chatter”. Switch chatter is a rapid On-Off cycling of not only the pressure switch but also the motor. It will burn the points in the switch, the motor points, and cause motor damage if not corrected. If for

any reason you must have fittings or filters between the pump and tank and they cause switch chatter you should move the pressure switch to the tank cross tee. Go To “Install HydroPro Water Systems Tank” to Complete Shallow Well Installation.

DEEP WELL TWIN PIPE – *start here*

Twin Pipe Suction Piping

A twin pipe jet assembly is used in wells 4" and larger. Our 4" jet assemblies require a minimum 1¼" suction and 1" drive water pipe; 5" jets require a minimum 1½" suction and 1¼" drive water pipe. Use of smaller piping will reduce performance in gpm and pressure. Offsets over 50' require larger pipes to reduce friction loss and to obtain published performance.

Install Twin Pipe Jet Assembly



Check to make sure the nozzle is installed in the jet assembly. Install the venturi tube in line with the nozzle. On 4" jets attach the 1¼" suction and 1" pressure pipe to the jet assembly female threads. On 5" jets the pipes should be 1½" and 1¼". Install a foot valve on the male thread bottom port on the jet assembly or on the end of a 34' tail pipe. The tail pipe prevents over pumping a low yield well so the pump will not break suction. *See Tail Pipe in Technical Section.*

Lower the jet assembly into the well. It should be set at least 5' below the static water level. Keep the jet a few feet off the well bottom to lessen the possibility of sucking debris into the jet. The connections at the well head can be either a pitless adapter or a well seal. Priming will be easier if you fill the pipes with water before attaching the pump.

Connect the suction and pressure pipes to the threaded connections on the face of the pump. This can be done using unions and threaded pipe nipples, or barbed connectors with poly pipe. Always double clamp barbed connectors. Make sure that the piping slopes upward to the pump and that no point is above the pump suction. On long offsets it is easier to prime the system if you fill the pipes with water before connecting the pipes to the pump. *Go to Deep Well Discharge Piping.*

DEEP WELL PACKER SYSTEM – *start here*

Packer Suction Piping



Packers use the area between the well casing and the suction pipe as the drive water (pressure) pipe. The 2" or 3" well casing must be smooth and clean to insure a good seal with the packer leathers or the system will leak and not hold prime. The 2" packer requires 1¼" threaded suction pipe and the 3" requires 1½". On 2" packers only: Use the Goulds Pumps turned couplings part #64655 to connect the sections of 1¼" threaded pipe. This special diameter turned coupling increases the clearance between the 2" well I.D. and the O.D. of the coupling to allow the drive (pressure) water to easily pass the couplings. Failure to use them will have a negative impact on pump performance, both pressure and gpm will decrease. The pump may easily lose prime while pumping due to the restriction!

Using smaller than recommended pipe may reduce gpm output. The longer the pipe the worse the affect.

Install Packer Assembly

To ease installation soak the 2" or 3" packer assembly in warm water to make the leathers soft and pliable. DO NOT lubricate them with grease, oil, or petroleum jelly! The leathers must absorb water to seal the packer assembly against the well casing.

Check to make sure the nozzle is installed in the jet assembly. Install the venturi tube in line with the nozzle. Install a strainer (not supplied with packer assembly) on the bottom port of the packer assembly or on the end of a 34' tail pipe. The tail pipe prevents over pumping a low yield well so the pump will not break suction. Attach the packer assembly to the suction pipes using the Goulds Pumps' turned couplings to connect the sections. Insert the packer assembly into the well casing and push it down. Attach the other pipe sections as you lower the jet into the well. *See Tail Pipe in Technical Section.*

Attach Suction Pipe To Packer Adapter

Packer systems always require a Packer Adapter at the well head. The adapter makes the transition from vertical to horizontal for horizontal pumps, and it connects vertical pump casings to the well casing and suction pipe. See the list of Packer Adapters/Pump Models to see which one your pump system requires. *See Chart 1 for a list of Packer Adapters/Pump Models.*

After the jet assembly is inserted into the well, attach the Packer Adapter to the top of the suction pipe. Screw the top section of 1¼" male threaded suction pipe or a threaded adapter into the 1¼" NPT female threaded hole in the 2" packer adapter or a 1½" suction pipe into the 3" packer adapter.

Make sure that the O.D. of the well casing is free of dirt and burrs. With the gland bolts loosened the tapered seal ring on the packer adapter should slide over the well casing. After insuring that it is in place tighten the two gland nuts to compress the seal ring and seal it to the well casing O.D.

Install the pump by attaching it to the Packer Adapter using the bolts and gaskets provided. Vertical models use studs and nuts for ease of assembly.

DEEP WELL DISCHARGE PIPING

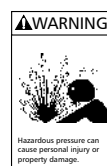

All deep well jet pumps require back pressure to operate the jet assembly. To insure we have the required back pressure or drive water pressure we must use a pressure control valve or some type of flow restrictor in the discharge line. The valve must be located between the pump and the first discharge port. It is best to locate it as close to the pump as possible. Failure to install and adjust a pressure control valve will result in loss of prime during peak usage such as filling a washing machine, bathtub or using outside hose bibs.

All ½ hp pumps can use a simple gas cock or full port ball valve, such as our AV15.

All other horizontal deep well jet pumps, ¾ hp and larger, should use an AV22KIT, or an AV22 and a JDW tubing kit. The AV22 has a tapping to which you connect the new, longer pressure switch tubing. This allows the pressure switch to read the pressure on the outboard side of the valve rather than in the pump casing. Remove the straight or elbow compression fitting from the pump casing. Use the pipe plug in the JDW or AV22KIT to plug the hole in the pump casing. Remove the fitting from the pressure switch. Cut the old tubing in half and slide the compression fittings off the old tubing. Note that the fitting will only slide in one direction. You can now reuse the elbow compression fitting with the new tubing at the pressure switch. Screw the new straight connector into the AV22 and attach the tubing from the switch to the AV22.

Vertical deep well pumps come with a built-in AV21 and only need to be adjusted.

After the pump is primed and flowing water at a steady pressure you should open a few faucets and adjust the pressure control valve to the pressure listed in the chart. To increase pressure close the valve, AV15 or AV22, or turn the AV21 screw clockwise. *See Chart 1.*

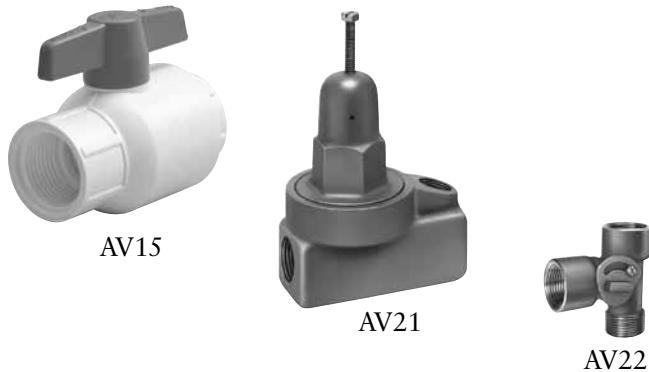

Fig. 4

ALL SYSTEMS

Install HydroPro Water Systems Tank



While the tank is empty check the pre-charge air pressure with a tire pressure gauge. The tank pre-charge should be set 2 psi lower than the pump cut-in (turn on) pressure. On Goulds Pumps HydroPro Water Systems tanks the valve cap is the primary seal so be sure to re-install the cap after checking air pressure.

Avoid frequent air checking as you lose 1 – 2 psi every time you check. Goulds Pumps jet pumps are all supplied with 30 – 50 psi standard pressure switch settings.

Locate the tank on a firm, level surface.

A pressure relief valve is recommended for all systems, and mandatory for systems producing over 100 psi. It should be rated less than 100 psi but greater than the system pressure near the tank.

Make the piping connection between the pump discharge and the tank. Complete the piping by connecting to the house plumbing.

Note: Goulds Pumps only sells the HydroPro Water System tanks. They are all shipped with a tank installation guide in the carton, please refer to it for more detailed

tank instructions. If you are using a tank from another manufacturer please contact that company for specific instructions on their tank.

Galvanized tanks are installed the same as pre-charged tanks except they require an Air Volume Control (AVC) to replenish air lost through absorption. The AVC requires connection to a vacuum port on the pump. The suction side of the AVC must have a minimum 3" vacuum for 15 seconds when the pump starts. Follow the instructions provided with the air volume control.

Priming a Shallow Well System

Priming means filling the pump and suction pipe with water. Most shallow well jet pumps handle air well and will evacuate air from the suction line but it may take several minutes to prime depending on depth to water, and pipe size and length.

VENT THE PUMP FOR EASIER PRIMING!

It is easier to prime a pump if you allow all the air to escape from the pump and the pipes, the water cannot go in unless the air can escape!

Remove the pipe plug or pressure gauge bushing in the discharge tee to fill the pump with water. On shallow well pumps you should remove the ⅛" pipe plug located between the suction and discharge ports to allow air to escape as you fill the casing with water. The port will be located on either the top of the casing or the top of the shallow well adapter. Fill the pump and as much of the suction pipe as possible with water through the discharge port.

Replace the ⅛" pipe plug and discharge gauge/bushing. Open the faucet closest to the pump/tank a small amount to allow air to escape the system. Do not open it too much or the pump will expel too much water and you will have to reprime the pump casing. On jobs with long suction pipes you may have to add water to the pump casing several times to complete the priming process. *Go to Power Motor.*

Priming a Deep Well System

Priming a deep well system means filling the pump and the suction/pressure pipes with water. Deep well single stage and multi-stage pumps require a complete prime before starting. Filling the pipes with water before installing the pump will make priming faster and easier.

VENT THE PUMP FOR EASIER PRIMING!

To insure a complete prime we recommend removing the angled ⅛" vent plug located just above the suction pipe on horizontal pumps. This will allow the air to easily escape as water enters. Our horizontal convertible deep well jets should be primed through a tee or the AV22 at the pump discharge. The tee is not supplied by Goulds Pumps.

Our vertical deep well jet pumps have built-in pressure control valves. Priming is done through the pressure gauge port on the pressure control valve. Most verticals have a vent plug located on the side of the motor adapter that vents the seal cavity which is the high point inside the pump. Removing this vent plug will make priming much easier.

Power the Motor



The electrical supply must be a separate branch circuit with a properly sized breaker or fuses. All wiring must conform to National (NEC), CSA, state, provincial, and local codes. Power supply voltage, phase and controls must match motor.

NEVER RUN A PUMP DRY, DAMAGE WILL RESULT, AND THE WARRANTY WILL BE VOIDED!



ALWAYS DISCONNECT AND LOCK-OUT ALL ELECTRICAL POWER WHEN INSTALLING OR WORKING ON PUMPS, MOTORS, OR SWITCHES. INSURE THE POWER SUPPLY BREAKER IS OFF OR THE DISCONNECT (WHERE USED) IS OFF.

Remove the pressure switch cover. Attach the power supply wires, either 115 or 230 depending on the motor voltage, to the Line terminals of the pressure switch.

Attach the green or bare ground wire to either green ground screw in the switch. It makes no difference which Line terminal you attach the hot- L1 (usually Black) and neutral- N (usually white) 115 volt wires to on the switch. The same goes for a 230 volt hook-up, either wire can go on either Line terminal. Re-install the switch cover. **NOTE:** Motor voltage is NOT changed in the pressure switch. See Fig. 7 in *Technical Data*.

Check to insure that the motor is wired to match the incoming voltage. All motors have a sticker near the pressure switch that identifies the pre-wired voltage. All ½ hp jet pumps are factory wired for 115 V, and ¾ hp and larger are wired for 230V. The motor voltage must be changed inside the motor cover, not in the pressure switch. Make sure the breaker or disconnect is OFF before entering the motor cover. All motors have a wiring diagram on the cover label and it is also found in this manual. See *Motor Wiring Diagram, Fig. 7, in Technical Data*.

BOOSTER SYSTEMS

Use the basic instructions for either a Shallow Well or Convertible with Shallow Well Adapter. If a city water booster system please plumb per Fig. 5

J, JS, JRS OR HSJ SERIES

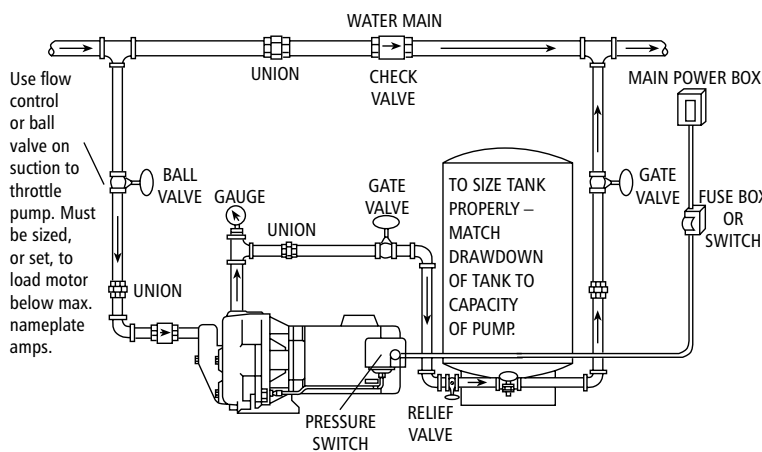

Fig. 5

If pumping from a cistern or water tank plumb per Fig. 6.

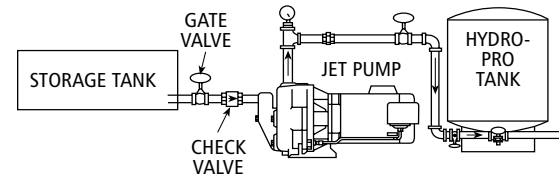

Fig. 6

SEASONAL SERVICE

It is necessary to drain the entire system where the pump, tank, and piping will be subjected to freezing. Vertical pumps have a drain plug located on the side of the pump casing near the bottom of the pump. Horizontal pumps may have two drain plugs, one on the casing (part where pipes attach) and another on the motor adapter. They are also located near the bottom of the pump. Multi-stage pumps also have 1 or 2 drain plugs and they may require you to tip the pump or blow compressed air in one hole to get all the water out of the stages.

CHART 1

RECOMMENDED DEEP WELL JET ASSEMBLIES AND CONTROL VALVE SETTINGS

PUMP MODEL	TWIN PIPE SYSTEMS (see fig. 2)				PACKER SYSTEMS (see fig. 3)					RECOMMENDED CONTROL VALVE (see fig. 4)
	JET ASSEMBLY	MIN. WELL DIAMETER	CONTROL VALVE SETTING (PSI)	DEPTH TO JET	JET ASSEMBLY	WELL DIAMETER	CONTROL VALVE SETTING (PSI)	DEPTH TO JET	PACKER ADAPTER	
J5	FT4-13	4"	30	30-40	FP2-13	2"	30	30-40	AWJ2	AV15 or AV22KIT
	FT4-31	4"	30	30-60	FP2-31	2"	30	30-60		
	FT4-08	4"	30	60-90	FP2-08	2"	30	60-80		
	FT5-14	4½"	30	50-90	FP3-36	3"	30	30-70	AWCJ3	
	—	—	—	—	FP3-24	3"	30	50-80		
J7	FT4-14	4"	28	30-60	FP2-40	2"	30	30-60	AWJ2	AV22KIT or AV22 and JDW
	FT4-34	4"	29	70-90	FP2-47	2"	32	60-90		
	FT4-18	4"	30	90-110	—	—	—	—	—	
	FT5-47	4½"	28	30-70	FP3-53	3"	27	30-70	AWCJ3	
	FT5-48	4½"	40	70-110	FP3-54	3"	30	70-110		
J10	FT4-44	4"	31	30-60	FP2-48	2"	35	30-60	AWJ2	AV22KIT AV22 and JDW
	FT4-43	4"	33	60-80	FP2-43	2"	36	60-100		
	FT4-18	4"	35	80-110	—	—	—	—	—	
	FT5-49	4½"	30	30-80	FP3-55	3"	28	30-80	AWCJ3	
	FT5-11	4½"	32	80-120	FP3-14	3"	32	80-120		
J15	FT5-12	4½"	35	30-70	FP3-16	3"	34	30-60	AWCJ3	AV22KIT AV22 and JDW
	FT5-11	4½"	40	70-140	FP3-18	3"	34	60-90		
	—	—	—	—	FP3-21	3"	34	90-150		
	—	—	—	—	FP3-24	3"	39	100-170		
SJ07 & HSJ07	FT4-48	4"	37	30-70	FP2-51	2"	40	30-70	AWD2	SJ - AV21 is built-in HSJ - use AV22KIT
	FT4-47	4"	40	70-90	FP2-50			70-90		
	FT4-06	4"		90-130	FP2-06			90-130		
					FP3-40	3"	36	30-80	AWD3	
				FP3-42	80-130					
SJ10 & HSJ10	FT4-47	4"	40	30-70	FP2-50	2"	45	30-60	AWD2	
	FT4-24	4"	43	70-110	FP2-07			60-110		
	FT4-08	4"		110-150	FP2-08			110-150		
					FP3-40	3"	40	30-90	AWD3	
				FP3-49	43			90-150		
SJ15 & HSJ15	FT4-45	4"	62	30-90	FP2-49	2"	62	30-90	AWD2	
	FT4-30	4"	65	90-130	FP2-30			90-130		
	FT4-29	4"	67	130-190	FP2-29			130-180		
					FP3-47	3"	62	30-100	AWD3	
					FP3-46			64		100-150
				FP3-34		66	150-210			
SJ20 & HSJ20	FT4-45	4"	76	30-100	FP2-49	2"	76	30-100	AWD2	
	FT4-30	4"	78	100-150	FP2-30			78		100-150
	FT4-29	4"	80	150-200	FP2-29			80		150-200
					FP3-47	3"	75	30-110	AWD3	
					FP3-46			78		110-170
				FP3-34		80	170-230			

NOTE: Offset adapters are available. See "Fittings" section of your Goulds Pumps Jet and Sub Catalog or consult your local distributor for information.

CHART 1 *(continued)*

RECOMMENDED DEEP WELL JET ASSEMBLIES AND CONTROL VALVE SETTINGS

PUMP MODEL	TWIN PIPE SYSTEMS <i>(see fig. 2)</i>				PACKER SYSTEMS <i>(see fig. 3)</i>					RECOMMENDED CONTROL VALVE <i>(see fig. 4)</i>	
	JET ASSEMBLY	MIN. WELL DIAMETER	CONTROL VALVE SETTING (PSI)	DEPTH TO JET	JET ASSEMBLY	WELL DIAMETER	CONTROL VALVE SETTING (PSI)	DEPTH TO JET	PACKER ADAPTER		
JRD5	FT3-09	3"	30	30-50	FP2-13	2"	30	30-50	AWJ2	AV15 or AV22KIT	
	FT4-13	4"	30	30-50							
	FT4-31	4"	30	30-70	FP2-31	2"	30	30-60			
	FT4-08	4"	30	60-90	FP2-08	2"	30	60-80			
	FT5-14	4½"	30	70-90							
JRD7	FT4-14	4"	27	30-60	FP2-40	2"	30	30-60	AWJ2	AV22KIT AV22 and JDW	
	FT4-34	4"	29	60-90	FP2-47	2"	32	60-90			
	FT4-18	4"	30	90-110							
	FT5-47	4½"	27	30-70	NA						
	FT5-48	4½"	30	70-110	NA						
JRD10	FT4-44	4"	31	30-60	FP2-48	2"	35	30-60	AWJ2	AV22KIT AV22 and JDW	
	FT4-43	4"	33	60-80	FP2-43	2"	36	60-100			
	FT4-18	4"	35	80-110							
	FT5-49	4½"	28	30-80	NA						
	FT5-11	4½"	32	80-120	NA						
VJ05	FT4-46	4"	23	30-60	FP2-38	2"	23	30-60	AWD2	AV21 is built-in	
	FT4-08	4"		60-90	FP2-08			60-90			
				30-60	FP3-42	3"	30-60	AWD3			
				60-100	FP3-09		60-100				
VJ07	FT4-47	4"	34	30-60	FP2-50	2"	34	30-60	AWD2		
	FT4-46	4"		60-90	FP2-47			60-100			
	FT4-06	4"	40	90-110	FP2-09			100-120			
					FP3-40			30-60	AWD3		
					FP3-43			60-130			
VJ10	FT4-14	4"	34	30-90	FP2-48	2"	36	30-60	AWD2		
	FT4-09	4"	36	90-120	FP2-43			60-100			
					FP2-08			100-120			
					FP3-40	3"	30-90	AWD3			
					FP3-49		36		90-140		

NOTE: Offset adapters are available. See "Fittings" section of your Goulds Pumps Jet and Sub Catalog or consult your local distributor for information.

CHART 2

SHALLOW WELL JET ASSEMBLIES FOR CONVERTIBLE PUMPS

PUMP MODEL	SHALLOW WELL ASSEMBLY ORDER NO.	INCLUDES	
		NOZZLE	VENTURI
J5	FH5 (std.)	AN017	AD3731
J5	FH5H (high pres.)	AN019	AD3528
JRD5	FH5JRD	AN018	AD3731
J7, JRD7	FH7	AN018	AD3536
J10, JRD10	FH10	AN018	AD3538
J15	FH15	AN022	AD3542
HSJ07N	FHSJ07	AN012	AD3432
HSJ10N	FHSJ10	AN012	AD3437
HSJ15N	FHSJ15	AN012	AD3439
HSJ20N	FHSJ20	AN012	AD3448

TECHNICAL DATA

WARNING: DISCONNECT POWER SOURCE BEFORE CHECKING. DO NOT MAKE ANY CHANGES WITH POWER ON.

VOLTAGE CHANGES ARE MADE INSIDE THE MOTOR COVER, NOT IN THE PRESSURE SWITCH.

VOLTAGE CHANGE PROCEDURE AND TERMINAL BOARD DESIGN

A.O. Smith jet pump motors have a voltage plug to facilitate simple voltage changes from 115V to 230V. All ½ HP motors are factory wired for 115V operation. If wired for 115V, operation at 230V will destroy the windings in a matter of seconds and will not be covered by warranty. Larger HP motors are factory wired at 230V.

Terminal Board Design:

- L1 has two (2) male terminals, one switch wire is attached to one terminal.
- L2 has two (2) male terminals, one switch wire is attached to one terminal and when set up for 115V operation the voltage plug is connected to the other.
- “A” has 1 male terminal, the voltage plug is always connected to “A”.

Voltage Change: *failure to follow these instructions may damage the windings*

- 115V - Place the Black voltage plug on the open L2 male terminal and the “A” terminal.
- 230V - Place the Black voltage plug only on the “A” male terminal. The 2nd L2 male terminal will be open.

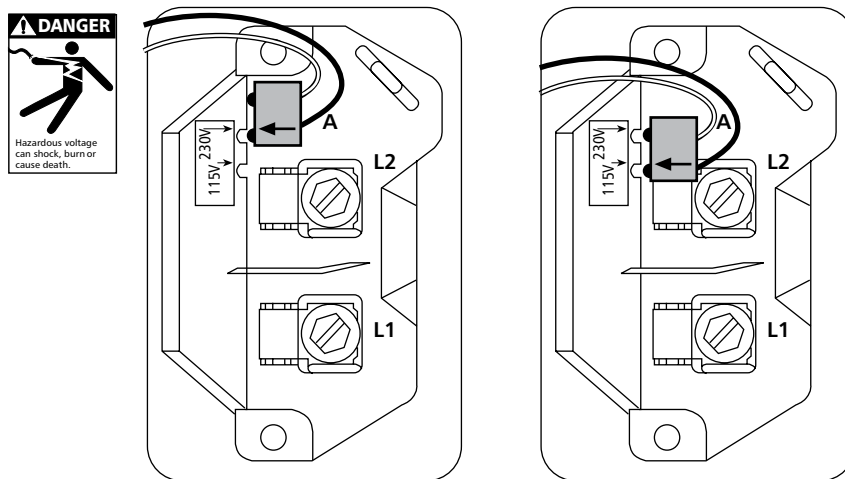

Fig. 7

A.O. SMITH MOTOR TERMINAL BOARD AND VOLTAGE CHANGE PLUG



■ Pumps are Pre-Wired by HP:

- ½ hp wired for 115 volts
- ¾ hp - 1½ hp and larger wired for 230 volts
- 2 hp is 230 volt only

A.O. SMITH MOTOR DATA

GP Number	Where Used	A.O. Smith Number	HP	Volts	Phase	Service Factor	Max. Load Amps	Watts	Circuit Breaker
J04853L	J5(S), GB	C48A93A06	½	115/230	1	1.6	10.8/5.4	968	25/15
J05853L	J7(S), GB, GT07, (H)SJ07, HSC07	C48A94A06	¾	115/230	1	1.5	14.8/7.4	1336	30/15
J06853L	J10(S), GB, GT10, (H)SJ10, HSC10	C48A95A06	1	115/230	1	1.4	16.2/8.1	1592	30/20
J07858L	J15(S), GB, GT15, HSJ15, HSC15	C48M2DC11A1	1½	115/230	1	1.3	21.4/10.7	1950	40/20
① J08854L	HSJ20, GB, GT20, HSC20	K48A34A06	2	230	1	1.2	12.9	2100	25
J09853	XSH30, GT30	C56P2U11A3HH	3	230	1	1.15	17.2	3280	30
SFJ04860	JRS5, JRD5, JB05	C48C04A06	½	115/230	1	1.6	12.6/6.3	990	25/15
SFJ05860	JRS7, JRD7, JB07	C48C05A06	¾	115/230	1	1.5	14.8/7.4	1200	30/15
SFJ06860	JRS10, JRD10, JB10	C48C06A06	1	115/230	1	1.4	16.2/8.1	1400	30/20

① Effective July, 1998, 230 V only.

USE OF TAILPIPE ON DEEP WELL JET PUMPS

If the capacity of a deep well jet pump exceeds the well production, well drawdown will allow your pump to break suction and lose prime. This can be overcome by using a 34' tailpipe between the jet assembly and the foot valve. Since the capacity of a pump falls off as the lift is increased your well inflow and pump output will equalize somewhere between the jet and foot valve. The drawing shows the percentage of rated capacity you will get at certain points. As in a normal situation the jet should be set 5' below the static water level.

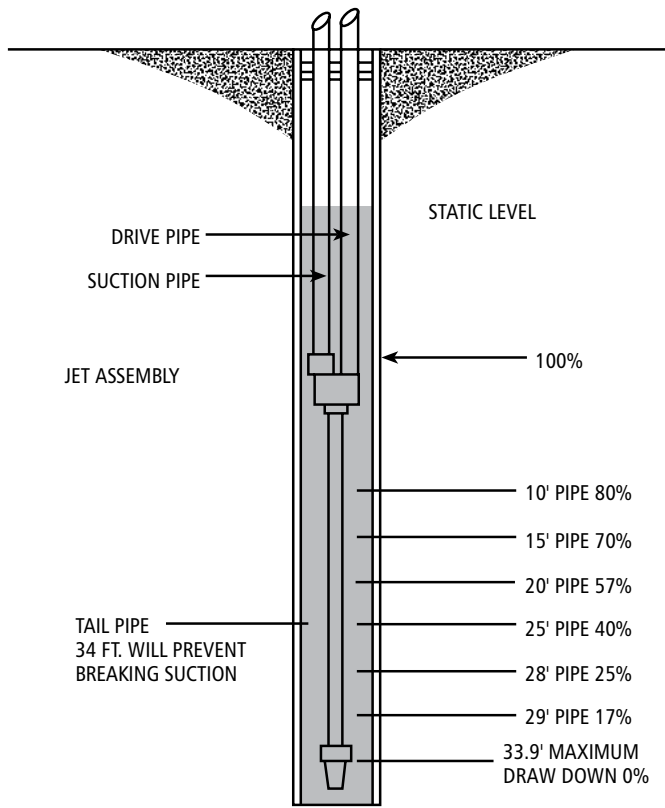

Fig. 8

CHECKING SUCTION LIFT ON A SHALLOW WELL

A vacuum gauge indicates Total Suction Lift (vertical lift + friction loss) in inches of mercury (Hg.). One inch (1") on the gauge = 1.13 feet of total suction lift (based on a pump at sea level). Practical suction lift at sea level is 25' or 22" Hg. Deduct 1 ft. for each 1000 ft. above sea level.

Install the compound vacuum/pressure gauge in the 1/8" hole in the shallow well adapter or the 1/8" hole between the suction and discharge pipes on a dedicated shallow well pump. This is the same hole that is used to connect an air volume control.

Interpreting the gauge readings:

High Vacuum (22" or more)

- Suction pipe buried in mud
- Foot valve or check valve stuck closed
- Suction lift exceeds lift capability of pump

Low Vacuum or 0 vacuum

- Suction pipe not submerged
- Suction leak (check joints and especially unions)

Gauge needle fluctuates rapidly

- Gaseous well
- Air leak in suction line
- Well producing less than pump capacity (throttle a ball valve in suction line do not exceed 22" Hg.) to reduce pump capacity

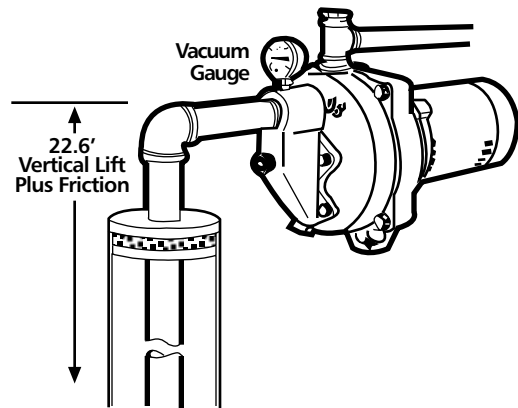
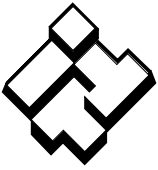

Fig. 9

A reading of 20" on a vacuum gauge placed on the suction side of the pump would tell you that you have a vacuum or suction lift of 22.6 ft.

$$20" \times 1.13' = 22.6 \text{ ft.}$$



ITT

TROUBLESHOOTING



FAILURE TO DISCONNECT AND LOCKOUT ELECTRICAL POWER BEFORE ATTEMPTING ANY MAINTENANCE CAN CAUSE SHOCK, BURNS OR DEATH.

SYMPTOM

MOTOR NOT RUNNING

See Probable Cause – 1 through 5

LITTLE OR NO LIQUID DELIVERED BY PUMP

See Probable Cause – 6 through 11

PUMP DELIVERS WATER – WILL NOT SHUT OFF

See Probable Cause – 9 through 13

PUMP CYCLES EXCESSIVELY

See Probable Cause – 14 through 17

PROBABLE CAUSE

1. Motor thermal protector tripped
2. Open circuit breaker or blown fuse
3. Impeller binding
4. Wiring incorrect/check motor voltage setting
5. Defective motor
6. Pump not primed, inadequate suction pipe submergence, air leak in suction pipe
7. Discharge or suction plugged, closed valve(s)
8. Low voltage causing reduced motor speed
9. Impeller worn or plugged, no jet assembly installed, or jet plugged
10. System head too high
11. Suction lift or suction losses excessive
12. Pressure switch plugged, incorrectly adjusted
13. Leaks in discharge piping or at house
14. Defective suction check or foot valve
15. Water logged pressure tank
16. Pump farther than 5 feet from tank
17. High friction loss valves between pump and tank. (Use only fully open gate valves)

GOULDS PUMPS LIMITED WARRANTY

This warranty applies to all water systems pumps manufactured by Goulds Pumps.

Any part or parts found to be defective within the warranty period shall be replaced at no charge to the dealer during the warranty period. The warranty period shall exist for a period of twelve (12) months from date of installation or eighteen (18) months from date of manufacture, whichever period is shorter.

A dealer who believes that a warranty claim exists must contact the authorized Goulds Pumps distributor from whom the pump was purchased and furnish complete details regarding the claim. The distributor is authorized to adjust any warranty claims utilizing the Goulds Pumps Customer Service Department.

The warranty excludes:

- (a) Labor, transportation and related costs incurred by the dealer;
- (b) Reinstallation costs of repaired equipment;
- (c) Reinstallation costs of replacement equipment;
- (d) Consequential damages of any kind; and,
- (e) Reimbursement for loss caused by interruption of service.

For purposes of this warranty, the following terms have these definitions:

- (1) "Distributor" means any individual, partnership, corporation, association, or other legal relationship that stands between Goulds Pumps and the dealer in purchases, consignments or contracts for sale of the subject pumps.
- (2) "Dealer" means any individual, partnership, corporation, association, or other legal relationship which engages in the business of selling or leasing pumps to customers.
- (3) "Customer" means any entity who buys or leases the subject pumps from a dealer. The "customer" may mean an individual, partnership, corporation, limited liability company, association or other legal entity which may engage in any type of business.

THIS WARRANTY EXTENDS TO THE DEALER ONLY.

Goulds Pumps is a registered trademark of ITT Corporation. ITT, the Engineered Blocks Symbol and Engineered for life are Registered trademarks of ITT Manufacturing Enterprises, Inc.

SPECIFICATIONS ARE SUBJECT TO CHANGE WITHOUT NOTICE.

IM102 Rev 3 June, 2009

Copyright (c) 2009 ITT Corporation

Engineered for life