

# USE AND CARE GUIDE

---

## CONVERTIBLE JET PUMP

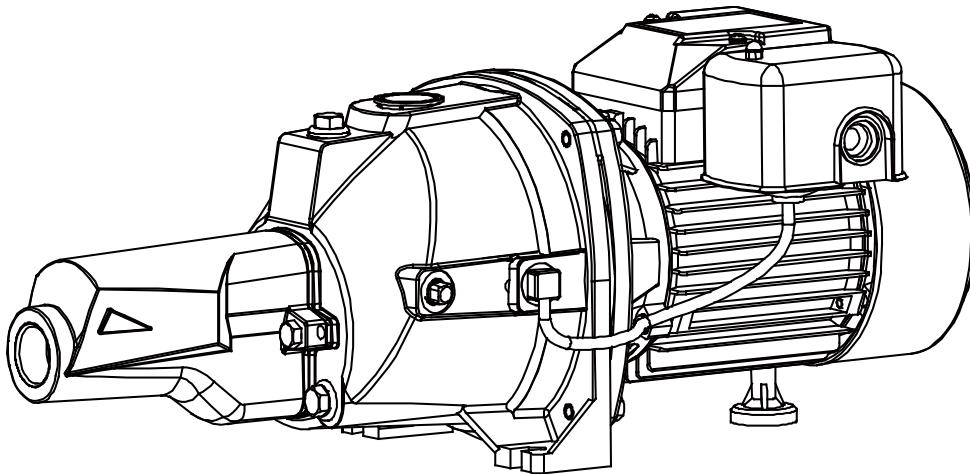

Questions, problems, missing parts? Before returning to the store call  
Everbilt Customer Service  
8 a.m. - 6 p.m., EST, Monday-Friday

**1-844-241-5521**

**WWW.HOMEDEPOT.COM**

---

### **THANK YOU**

*We appreciate the trust and confidence you have placed in Everbilt through the purchase of this convertible jet pump. We strive to continually create quality products designed to enhance your home. Visit us online to see our full line of products available for your home improvement needs. Thank you for choosing Everbilt!*

# Table of Contents

Table of Contents.....	2	Shallow Well Installation .....	5
Performance .....	2	Pressure Switch Assembly Instructions.....	10
Safety Information.....	2	Deep Well Installation.....	11
Warranty .....	3	Troubleshooting .....	17
Pre-Installation .....	4		

## Performance

SKU	HP	GPH of Water @ Total Discharge Pressure of 40 psi								Max. Pressure
		0 ft.	10 ft.	20 ft.	30 ft.	40 ft.	50 ft.	60 ft.	70 ft.	
1001480251	3/4	612	486	372	360	318	270	210	180	67 psi
1001480255	1	822	696	540	444	420	360	306	276	67 psi

## Safety Information



**DANGER:** Do not pump flammable or explosive liquids such as oil, gasoline, kerosene, ethanol, etc. Do not use in the presence of flammable or explosive vapors. Using this pump with or near flammable liquids can cause an explosion or fire, resulting in property damage, serious personal injury, and/or death.



**DANGER:** ALWAYS disconnect the power to the pump before servicing.



**DANGER:** Do not touch the motor housing during operation. The motor is designed to operate at high temperatures. Do not disassemble the motor housing.



**DANGER:** Do not handle the pump or pump motor with wet hands or when standing on a wet or damp surface, or in water.



**WARNING:** Wear safety goggles at all times when working with pumps.



**WARNING:** This is a dual voltage 115/230 V pump. VOLTAGE SELECTOR INSIDE PRESET TO 230V. For 115V selection, please open the terminal cover and set the switch to the proper voltage. All wiring should be performed by a qualified electrician.



**WARNING:** Protect the electrical cord from sharp objects, hot surfaces, oil, and chemicals. Avoid kinking the cord. Do not use damaged or worn cords.



**WARNING:** Failure to comply with the instruction and designed operation of this unit may void the warranty. ATTEMPTING TO USE A DAMAGED PUMP can result in property damage, serious personal injury, and/or death.



**WARNING:** The pump should be connected to a 230V/115V GFCI outlet protected with a 10 amp (230V)/20 amp(115V) fuse or circuit breaker.



**CAUTION:** Know the pump and its applications, limitations, and potential hazards.



**CAUTION:** Secure the pump to a solid base.



**CAUTION:** Periodically inspect the pump and system components. Disconnect the pump from the power supply before inspecting.

## Safety Information (continued)



**CAUTION:** Follow all electrical and safety codes, particularly the Canadian Electrical Code, and local codes and ordinances.



**IMPORTANT:** The motor of this pump has a thermal protector that will trip if the motor becomes too hot. The protector will reset itself once the motor cools down and an acceptable temperature has been reached. The pump may start unexpectedly if it is plugged in.



**IMPORTANT:** Ensure the electrical power source is adequate for the requirements of the pump.



**IMPORTANT:** This pump is made of high-strength, corrosion-resistant materials. It will provide trouble-free service for a long time when properly installed, maintained, and used. However, inadequate electrical power to the pump, dirt, or debris may cause the pump to fail. Please carefully read the manual and follow the instructions regarding common pump problems and remedies.

## Warranty

The manufacturer warrants the products to be free from defects in materials and workmanship for a period of one year from date of purchase. This warranty applies only to the original consumer purchaser and only to products used in normal use and service. If within one year this product is found upon examination by the manufacturer to be defective in materials or workmanship, the manufacturer's only obligation, and your exclusive remedy, is the repair or replacement of the product at the manufacturer's discretion, provided that the product has not been damaged through misuse, abuse, accident, modifications, alterations, neglect or mishandling. Your original receipt of purchase is required to determine warranty eligibility.

The purchaser must pay all labor and shipping charges necessary to replace the product covered by this warranty.

This Limited Warranty does not cover products which have been damaged as a result of an accident, misuse, abuse, negligence, alteration, improper installation or maintenance, or failure to operate in accordance with the instructions supplied with the products, or operational failures caused by corrosion, rust, or other foreign materials in the system.

Requests for service under this warranty shall be made by returning the defective product to the manufacturer as soon as possible after the discovery of any alleged defect. The manufacturer will subsequently take corrective action as promptly as reasonably possible.

The manufacturer does not warrant and especially disclaims any warranty, whether express or implied, of fitness for a particular purpose, other than the warranty contained herein. This is the exclusive remedy and any liability for any and all indirect or consequential damages or expenses whatsoever is excluded.

Some states do not allow the exclusion or limitation of incidental or consequential damages or limitations on how long an implied warranty lasts, so the above limitations or exclusions may not apply to you. This warranty gives you specific legal rights and you may also have other rights which vary from state to state.

Contact the Customer Service Team at 1-844-241-5521 or visit [WWW.HOMEDEPOT.COM](http://WWW.HOMEDEPOT.COM).

**For warranty registration please go to [www.gppumpsus.com](http://www.gppumpsus.com)**

# Pre-Installation

## APPLICATION

This unit is a convertible jet pump designed for pumping water where the water level is less than 70 ft. deep. If the water level to the pump is deeper than 70 ft., a deep well submersible pump should be selected. A pressure switch pre-set at 30 psi “on”/ 50 psi “off” has been installed on the pump. The pressure switch will automatically turn the pump on and off based on the system pressure.

## TOOLS REQUIRED

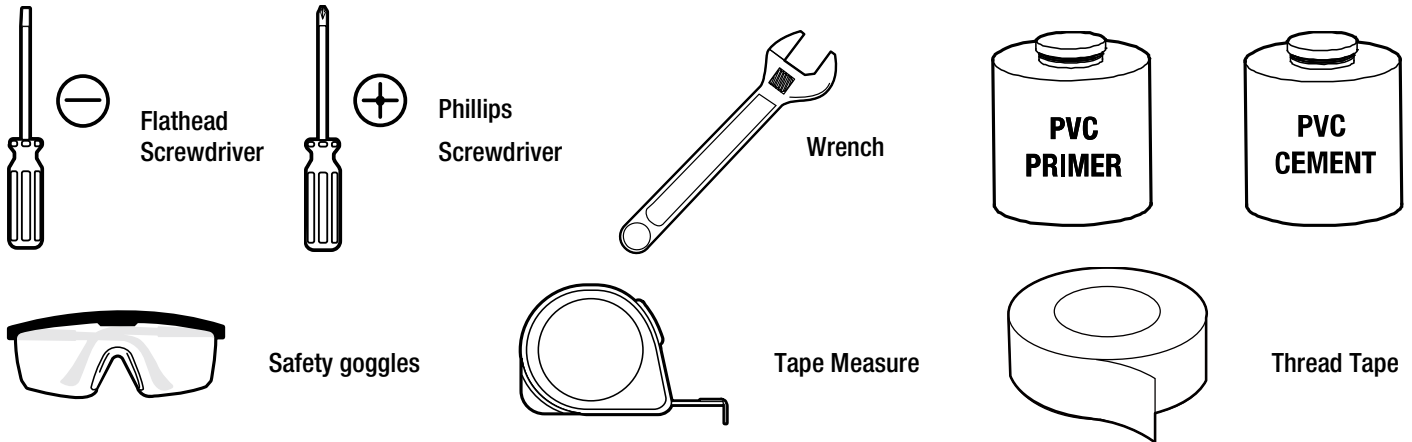

## PACKAGE CONTENTS

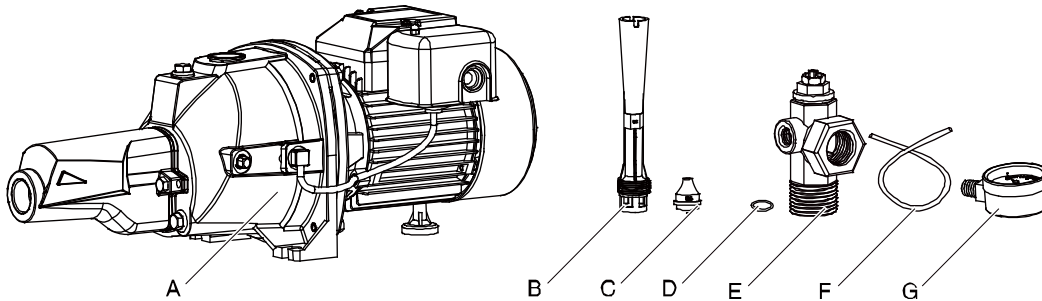

Part	Description
A	Pump
B	Venturi tube (J32P-18/#11)
C	Nozzle (#02)
D	O Ring

Part	Description
E	Pressure regulator
F	Pressure tube
G	Pressure gauge

## SPECIFICATIONS

<b>Power supply</b>	115V/230V, 60 HZ., 20/10 Amp Circuit
<b>Liquid temp. range</b>	32°F to 77°F (0°- 25°C)
<b>Discharge size</b>	1 in. FNPT
<b>Suction size</b>	1-1/4 in. FNPT
<b>Shallow well water level</b>	25 ft.
<b>Deep well water level</b>	70 ft.

# Pre-Installation (continued)

## DETERMINE THE DEPTH OF YOUR WELL

Tie a small but heavy weight such as a fishing weight to the end of a piece of cotton string. Lower the weight into the well until it reaches the bottom of the well. Make a mark on the string at ground level. Pull the weight out of the well and measure from the bottom of the weight to the ground level mark. This is the depth of your well. Subtract 5 ft. from the depth of your well. If this number is less than 25 ft., shallow well installation should be taken. If this number is more than 25 ft. and less than 70 ft., deep well installation should be taken. If this number is more than 70 ft., a deep well submersible pump should be selected. Measure the ground level mark to the mark where the cotton string is wetted. This number is your well's water level. It should also be at least 10 ft. below the well's water level while the pump is running in order to prevent the pump from sucking air due to water level drawdown.

## LOCATION OF THE PUMP

Decide on the area for the pump installation. Select a pump location with adequate space for future pump maintenance. It can be located in the basement or utility room of the house, at the well, or between the house and the well. If installed outside of the house, it should be protected by a pump house with auxiliary heat to prevent possible freezing. Protect the pump against flooding and excess moisture. The well also should be protected for sanitary reasons. Mount the pump as close to the well as possible.

## TANKS - PRE-CHARGED STORAGE

For best performance of the pump, it is recommended that you use a diaphragm pressure tank (sold separately). It is best to have this in place before installing the pump. A pre-charged storage tank has a flexible bladder or diaphragm that acts as a barrier between the compressed air and water. This barrier prevents the air from being absorbed into the water and allows the water to be acted on by compressed air at initially higher than atmospheric pressures (pre-charged). More usable water is provided than with a conventional type tank.



**CAUTION:** In order for the pump and tank to operate properly, the pressure tank needs to be drained of all water BEFORE INSTALLING THE NEW PUMP. After draining, if you are using the supplied 30/50 psi pressure switch at the pre-set settings, add or adjust the air pressure in the tank to 28 psi of pressure BEFORE startup.

**For wells 25 ft. or less in depth, shallow well installations should be adapted. The shallow well installations have only one single pipe between the pump and well water.**

## Shallow Well Installation

### MATERIALS REQUIRED (NOT INCLUDED)

One can PVC cement & primer (read instructions carefully)	One well seal with vent plug
One can thread compound (read instructions carefully)	Foot valve
Thread tape	Priming tee and plug
Rigid pipe	Relief valve
Check valve	Adaptor
Flexible plastic pipe/clamps	Tank
Tank tee	



**WARNING:** All joints and connections must be AIRTIGHT. A single leak will prevent the proper operation of the pump. Wrap thread tape clockwise on all threaded connections. For all non-threaded connections, you must use PVC Purple Primer and PVC Cement to ensure airtight seals. Measure all pipe lengths before attaching.



**NOTE:** A foot valve is a check valve that is used to keep the water from running back into the well from the pump and maintain hydraulic pressure when the pump is not running. If the foot valve does not hold the water the pump will lose its prime and will not pump water. If the foot valve open pressure is too high (the spring is too stiff), or the flow area is too small, the pump suction head and flow rate will significantly drop.



**NOTE:** The suction pipe size should not be less than 1-1/4 in. The suction size of this pump is 1-1/4 in. FNPT.

# Shallow Well Installation (continued)

## REPLACING AN EXISTING PUMP



**WARNING:** Risk of electric shock. Can shock, burn or kill. Disconnect power to pump before working on pump or motor.

1. Drain and remove the old pump. Check the old pipe for scale, lime, rust, etc., and replace it if necessary.
  2. Install the pressure gauge in the pump body.
  3. Install the pump in the system. Make sure that all pipe joints in the suction pipe are air-tight as well as water tight. If the suction pipe can suck air, the pump will not be able to pull water from the well.
  4. Adjust the pump mounting height so that the plumbing connections do not put a strain on the pump body. Support the pipe so that the pump body does not take the weight of piping or fittings.
- You have just completed the well plumbing for your new shallow well jet pump. Please go to discharge pipe and tank connections.

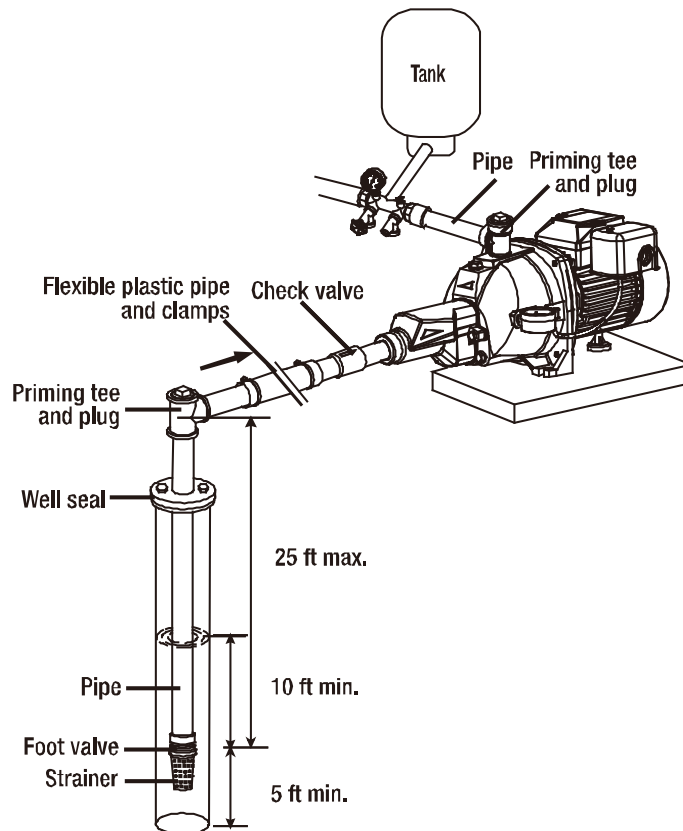

# Shallow Well Installation (continued)

## NEW SHALLOW WELL INSTALLATION



**CAUTION:** To avoid skin burns, unplug the pump and allow time for it to cool after periods of extended use.

### 1 Connecting a rigid pipe to the foot valve



**WARNING:** Read the cement instructions carefully and make sure the pipe connections are strong enough. This pump could build up to 70 psi pressure in the system. If the pipe joints are weak, the pipe and foot valve could pop out and fall into the well by the system high pressure.

- Subtract 5 ft. from the depth of your well. This is the total length of rigid pipe.
- Connect one section of rigid pipe to the foot valve.

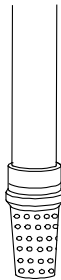

### 2 Sliding the pipe assembly into the well

- Before sliding the pipe assembly into the well, firmly clamp the assembly with a pipe clamp (not included) to prevent the assembly from sliding down into the well.



**NOTE:** DO NOT let the assembly slide down into the well.

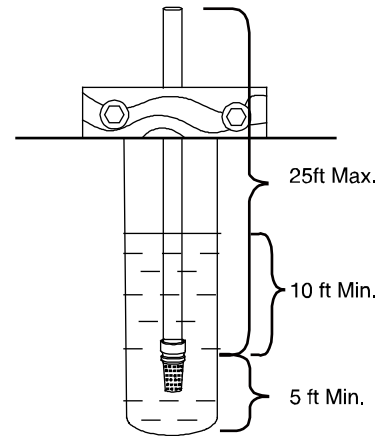

### 3 Sliding a well seal over the rigid pipe

- Remove the pipe clamp and slide a well seal (sold separately) over the rigid pipe and onto the well casing (not pictured).
- The rigid pipe should extend approximately 12 in. from the well seal, depending on the height of the pump.
- Tighten the well seal until the rubber gaskets are tight against the well casing and the rigid pipe.

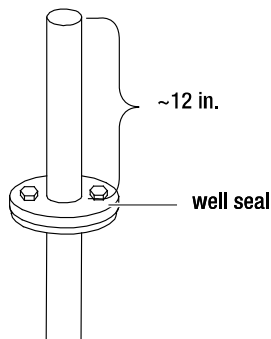

### 4 Attaching a tee to the rigid pipe

- Attach a 1-1/4 in. tee and plug (sold separately) onto the rigid pipe extending from the well seal.

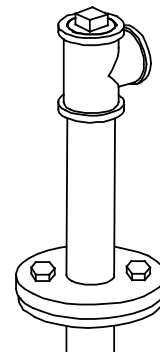

# Shallow Well Installation (continued)

## 5 Connecting the rigid pipe to the pump inlet

- Install pressure gauge in the pump body.
- Mount the pump as close to the well as possible.
- Connect a section of 1-1/4 in. rigid pipe to the pump inlet.
- Attach a check valve (sold separately) to the other end of the rigid pipe.
- Attach a section of 1-1/4 in. rigid pipe to the other end of the check valve.

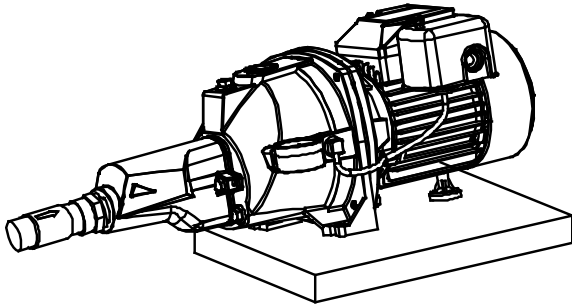

## 6 Connecting a flexible plastic pipe

- Connect a flexible plastic pipe to the 1-1/4 in. rigid pipe.
- Connect the other end of the plastic pipe to the rigid pipe extending from the well seal.
- Tighten the flexible plastic pipe two ends with clamps. Ensure the pipe slopes slightly toward the well (to prevent air trapping in the pipe).

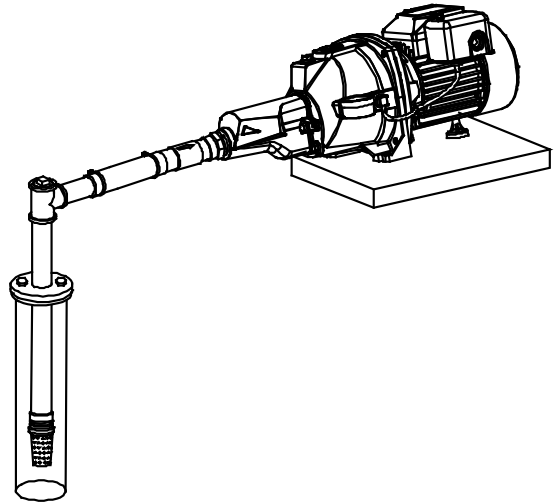

## 7 Connecting a discharge tee to the pump

- Wrap thread tape around threads of a 1 in. discharge tee (sold separately).
- Using a pipe wrench, thread the 1 in. discharge tee into the discharge hole on the top of the pump.

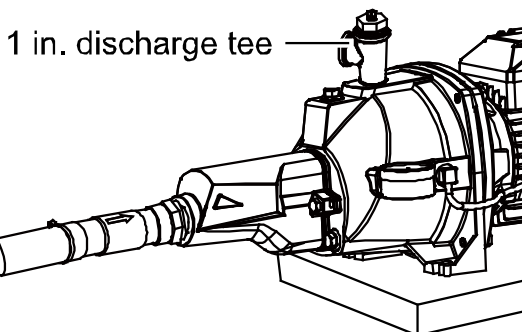

## 8 Connecting a PVC adaptor to the discharge tee

- Wrap thread tape around the threads of a 1 in. male PVC adaptor (sold separately).
- Thread the adaptor into the discharge tee.

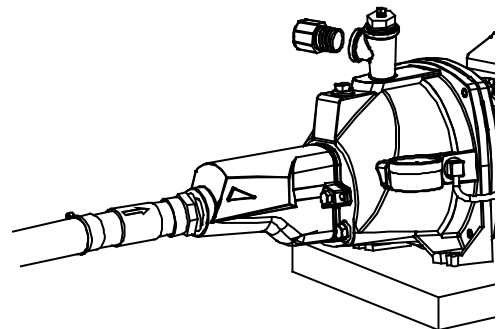



# Shallow Well Installation (continued)

## 9 Connecting a tank tee to the pressure tank

- Wrap all threads with thread tape.
- In order for the pump and the pressure tank (sold separately) to operate properly, the pressure tank needs to be drained of all water BEFORE INSTALLING IT TO THE PUMP.
- Thread a 10 in. tank tee (sold separately) or another necessary size tee into the pressure tank.
- Plug one outlet on top of the tank tee with a 1/4 in. plug (sold separately) and install a pressure gauge (sold separately) on the other outlet on top of the tank tee.
- Thread two 1 in. female PVC adaptors (sold separately) onto the two inlet sides of the tank tee.
- Thread a 1/2 in. relief valve and a 1/2 in. drain valve (both sold separately) to the front of the tank tee.

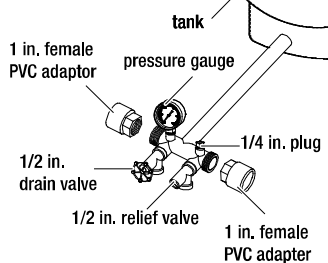

## 11 Connecting the pump with the water system



**CAUTION:** Never install a shut-off valve between the pump and the tank, as this can cause excessive friction loss and can damage the pressure switch and/or pump. If necessary, only install a fully open gate valve (sold separately).

- Using PVC purple primer and PVC cement, attach a section of 1 in. PVC pipe (sold separately) as needed to connect the 1 in. male PVC adaptor on the discharge tee to the 1 in. female PVC adaptor on the tank tee.
- Attach another section of 1 in. PVC pipe (sold separately) as needed to connect the other 1 in. female PVC adaptor on the tank tee to the water system from the house.

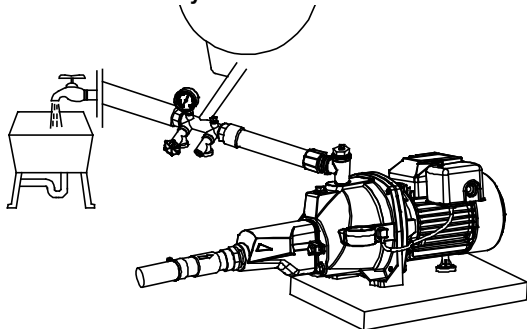

## 10 Checking the pressure in the tank

- Air pressure in the tank must be 2 psi lower than the "cut-in" of the pressure switch.



**NOTE:** The pump has a 30/50 psi pressure switch, which means the "cut-in" is 30 psi; therefore, the tank needs to be set to 28 psi. To check the pressure in the tank, use a tire pressure gauge (not included). If more air is needed, add air to the tank with a tire pump or air compressor. If less is needed, bleed out some air.

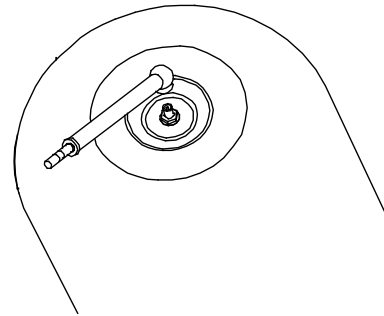

## 12 Priming the pump and rigid pipe



**WARNING:** If the pump's level is lower than the suction pipe, the air may trap in the pipe. The pump may not work properly.

- To prime, remove both:
  - a. The two plugs from the top of the two discharge tees (water will be filled in here), and;
  - b. The air plug in front of the discharge tee (this is to allow air to vent out while priming). Fill the two discharge tees with water until water overflows.



**NOTE:** It may take some time to fully fill the pipes and the pump completely. Keep watching the discharge tee water level and make sure the water level is stable and no air bubbles come out from the discharge tee.

- Wrap the two discharge tee plugs and air plug threads with thread tape and re-attach to the pump. Tighten with a wrench.

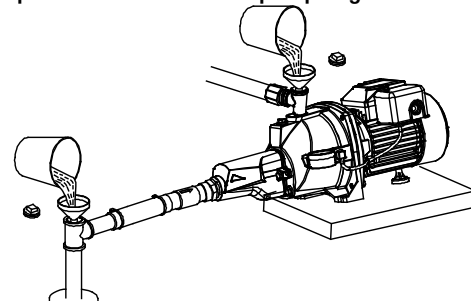

# Shallow Well Installation (continued)

## 13 Voltage setting



**WARNING:** All electrical work should be performed by a licensed electrician.

- This pump is pre-wired at 230 volts.
- If the power source is 115 volts, remove the electrical housing cover.
- Flip the switch to 115 volts.
- Replace the cover.

Proceed to the Pressure Switch Assembly Instructions section below.

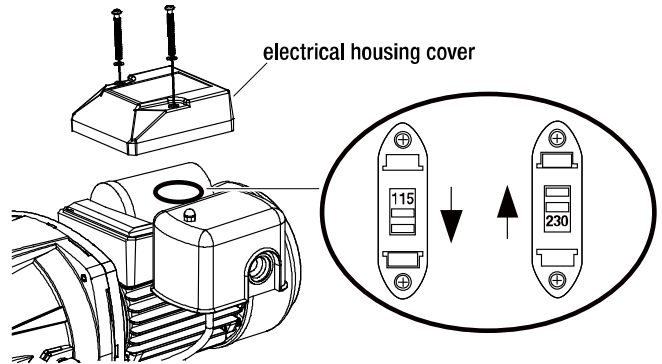

## Pressure Switch Assembly Instructions



**WARNING:** Before wiring the pressure switch, turn off the power source to which you are connecting to avoid potentially life threatening electrical shock.



**WARNING:** When wiring from the power source to the pressure switch, it is recommended that you use either a 14-gauge or 12-gauge cord.

To complete the installation, you must connect the power source to the pressure switch. A 30/50 psi pressure switch has been installed on the pump. The pressure switch allows for automatic operation; the pump starts when pressure drops to the “cut-in” setting (30 psi pre-set).

### To wire the pressure switch:

- Remove the pressure switch cover on pump to expose the wiring terminals.
- Connect the green ground wire of the power supply to the switch ground terminal.
- Connect the power supply wires to the two outside terminals marked “LINE” and replace the switch cover.



**CAUTION:** Do NOT use a pressure switch set at a pressure greater than 50 psi. The pump will not create pressures greater than 50 psi, if so the pump will never shut off, resulting in damage to the pump and voiding the warranty.



**WARNING:** It is recommended all electrical work be performed by a licensed electrician.

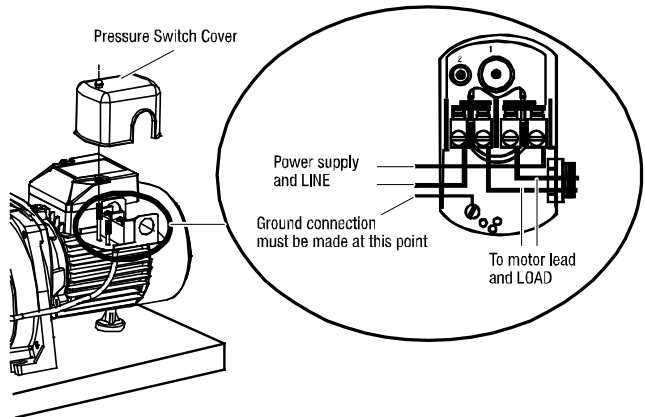

The pump is ready for use. Open a faucet near the pump. Turn on the pump. Water should come out from the faucet in a few minutes. If no water comes out, turn off the pump and re-prime water from the discharge tee.

**For wells between 25 and 70 ft. in depth, deep well installations should be adapted. The deep well installations have one 1-1/4 in. pipe and one 1 in. pipe between the pump and ejector.**

# Deep Well Installation

## MATERIALS REQUIRED (NOT INCLUDED)

One can PVC cement & primer (read instructions carefully)	One well seal with vent plug
One can thread compound (read instructions carefully)	Foot valve
Thread tape	Priming tee and plug
Rigid pipe	Relief valve
Check valve	Adaptor
Flexible plastic pipe/clamps	Tank
Elbow	Tank tee
Nipple	



**WARNING:** All joints and connections must be **AIRTIGHT**. A single leak will prevent the proper operation of the pump. Wrap thread tape clockwise on all threaded connections. For all non-threaded connections, you must use PVC purple primer and PVC cement to ensure airtight seals. Measure all pipe lengths before attaching.



**NOTE:** The ejector kit from the factory is for shallow well application. For deep well installation, the venturi tube (B) (J32P-18/#11) and nozzle (C) (#02) have to be installed.

## REPLACING AN EXISTING PUMP



**WARNING:** Risk of electric shock. Can shock, burn or kill. Disconnect power to pump before working on pump or motor.

1. Drain and remove the old pump and the ejector in the well. Check pipe for scale, lime, rust, etc., and replace it if necessary.



**NOTE:** Your old ejector (in the well) can't be properly matched to your new pump. You must use the included ejector to your new pump.

2. Refer the following instruction to finish the new pump installation.

## NEW DEEP WELL INSTALLATION (4" OR LARGER WELL)

### 1 Removing the pre-assembled nozzle and venturi

- Removing the pre-assembled ejector first then removing the pre-assembled nozzle and venturi.
- SKU 1001 480 251, Turn the venturi tube (#13) counter clockwise. Remove the venturi tube (#13) and nozzle (#04) with an O-ring from the ejector.
- SKU 1001 480 255, Turn the venturi tube (#14) counter clockwise. Remove the venturi tube (#14) and nozzle (#04) with an O-ring from the ejector.

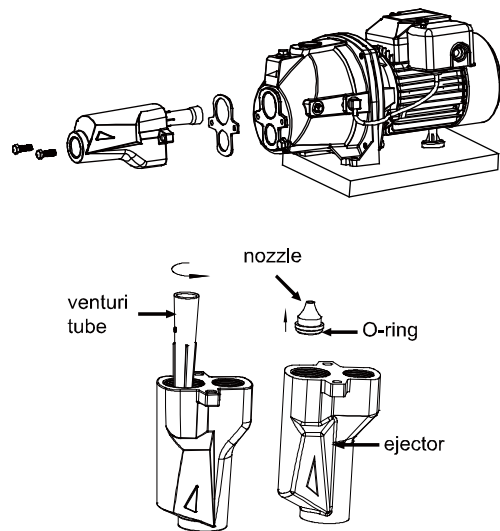

# Deep Well Installation (continued)

## 2 Attaching the nozzle and venturi to the ejector

- Wrap the threads of the venturi tube (B) (J32P-18/#11) with thread tape.
- Attach the O-ring (D) on the nozzle (C) (#02) and screw the nozzle (C) (#02) into the venturi tube (B) (J32P-18/#11).
- Attach the venturi tube (B) (J32P-18/#11) with the nozzle (C) and O-ring (D) to the Ejector.

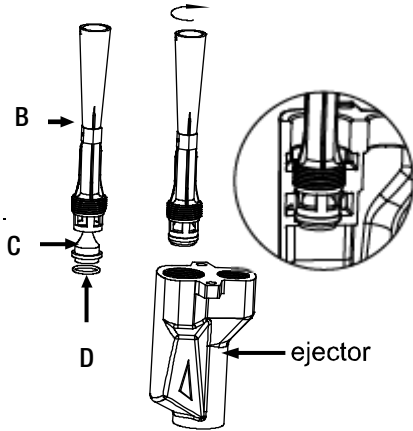

## 3 Connecting the foot valve to the ejector

- Wrap both ends of a 1-1/4 in. x 3 in. nipple (sold separately) with thread tape (sold separately).
- Thread the nipple into 1-1/4 in. foot valve (sold separately).
- Thread the other end of the nipple into the bottom of the ejector.
- Hand tighten, and then tighten 1-1/2 turn with a pipe wrench.

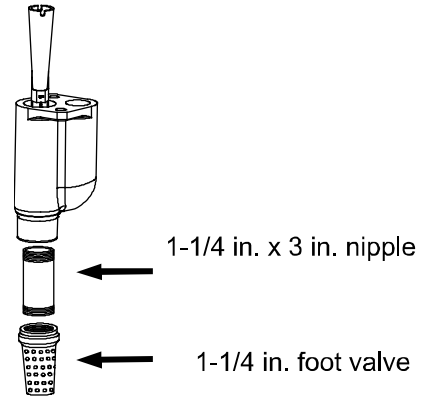

## 4 Connecting the rigid pipe to the ejector

- Connect two pipes (1 in. drive, 1-1/4 in. suction) to the ejector.



**NOTE:** If use PVC pipe to connect, a 1 in. x 3 in. nipple is required.

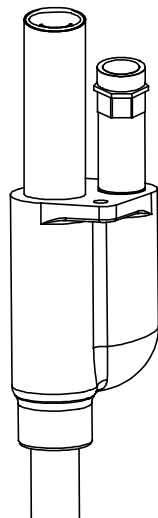

## 5 Sliding the pipe assembly into the well

- Before sliding the pipe assembly into the well, firmly clamp the assembly with a pipe clamp (not included) to prevent the assembly from sliding down into the well.
- Keep the 1 in. pipe 2 in. shorter than the 1-1/4 in. pipe.

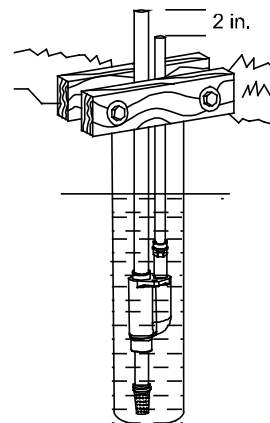

## Deep Well Installation (continued)

### 6 Sliding a well seal over the rigid pipe

- Remove the pipe clamp and slide a well seal (sold separately) over the rigid pipes and onto the well casing. The rigid pipe should extend approximately 12 in. from the well seal, depending on the height of the pump.



**NOTE:** DO NOT allow the assembly to slide down into the well. Tighten the well seal until rubber gaskets are tight against the well casing and the rigid pipes.

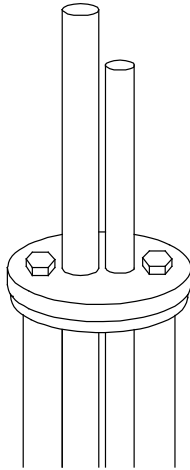

### 7 Attaching an elbow & tee to the rigid pipes

- Attach a 1 in. elbow and a 1-1/4 in. tee (both facing the pump) to the pipes extending from the well seal.
- Attach rigid pipes to 1 in. elbow and 1-1/4 in. tee separately.

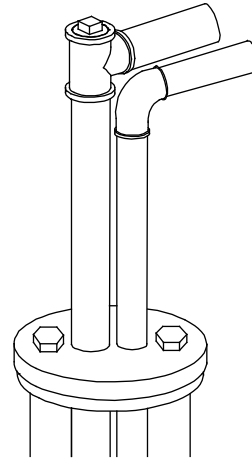

### 8 Connecting rigid pipe to the pump body

- Mount the pump as close to the well as possible.
- Attach two section of rigid pipes (1 in. drive, 1-1/4 in suction) to the pump body.



**NOTE:** If using PVC pipe to connect, a 1 in. x 3 in. nipple is required.

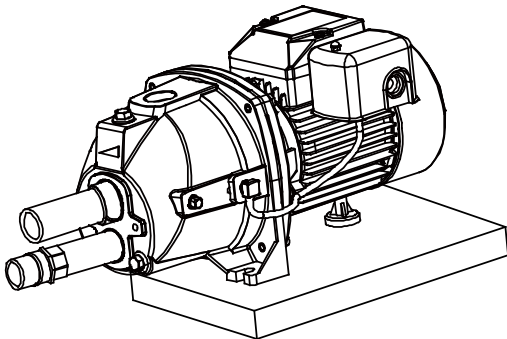

### 9 Connecting two flexible plastic pipes

- Connect a flexible plastic pipe (1-1/4 in.) to the 1-1/4 in. rigid pipe.
- Connect a flexible plastic pipe (1 in.) to the 1 in. rigid pipe.
- Connect the other end of the plastic pipes to the rigid pipes extending from the well seal.
- Tighten the flexible plastic pipe two ends with clamps. Ensure the pipe slopes slightly toward the well (to prevent air trapping in the pipe).

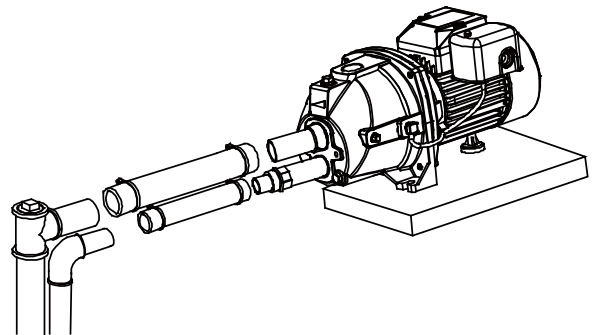

## Deep Well Installation (continued)

### 10 Removing the elbow insert from the pump body

- Pull out the pressure tube from the 90° elbow insert.
- Unthread and remove the elbow insert from the pump body.

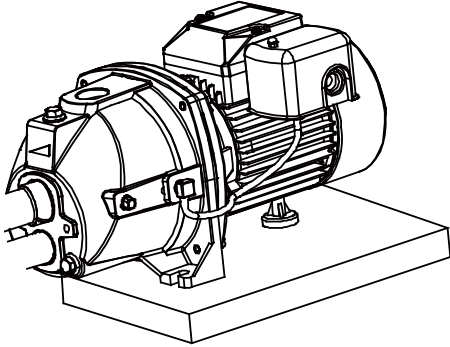

### 11 Connecting the pressure gauge to the elbow insert hole

- Wrap the threads of the 1/4 in. pressure gauge (included) with thread tape and thread it in the elbow insert hole.
- Cut off the expanded portion of the pressure tube.

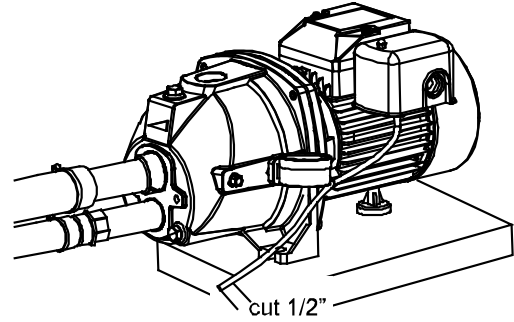

### 12 Priming the pipe & pump

- Fill the pipe with water until water overflows. Replace the plug back to the tee.
- Fill the pump with water until water overflows.



**NOTE:** It may take several minutes to fill the pipes and the pump completely.



**NOTE:** If the pump does not hold its prime, inspect all pipes and connections for leaks, and repair the leaks.

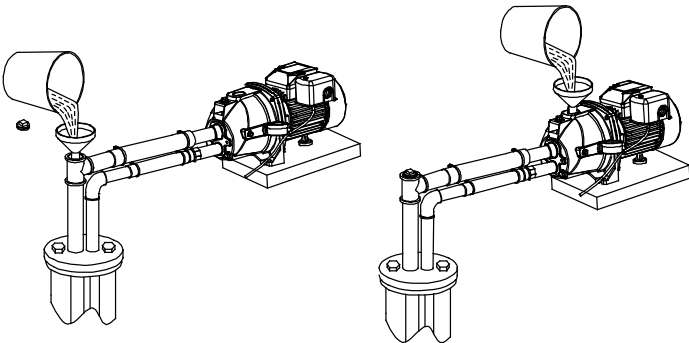

### 13 Connecting the pressure regulator to the pump

- Wrap thread tape around the threads of a 1 in. pressure regulator (E).
- Using a pipe wrench, thread the 1 in. pressure regulator (E) into the top of the pump.



**NOTE:** This pressure regulator is a normally-closed valve installed at the discharge of the pump to provide an obstruction to flow and thereby regulate the pump pressure and provide back pressure for the ejector. Failure to use this item may result in a loss of prime and/or a low pressure.

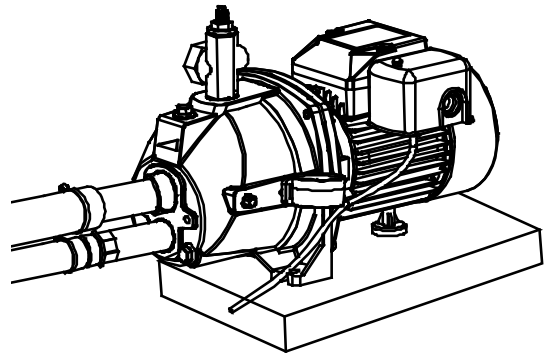

## Deep Well Installation (continued)

### 14 Connecting the brass elbow to the pressure regulator

- Thread the 1/4 in. disassembled elbow insert into the 1/4 in. hole on the side of the pressure regulator.
- Slide the pressure tubing (attached with the pump pressure switch or included in regulator kit) over the 1/4 in. brass elbow and the pressure switch connector.

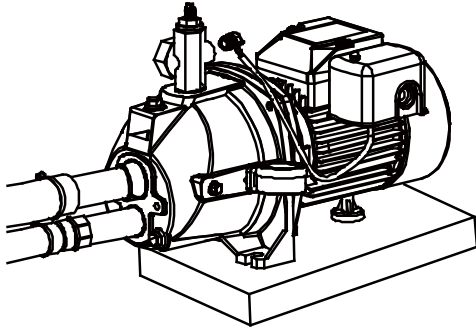

### 15 Connecting the PVC adaptor to the pressure regulator

- Wrap thread tape around the threads of a 3/4 in. MNPT x 1 in. slip PVC adaptor (sold separately).
- Thread the adaptor into the pressure regulator.

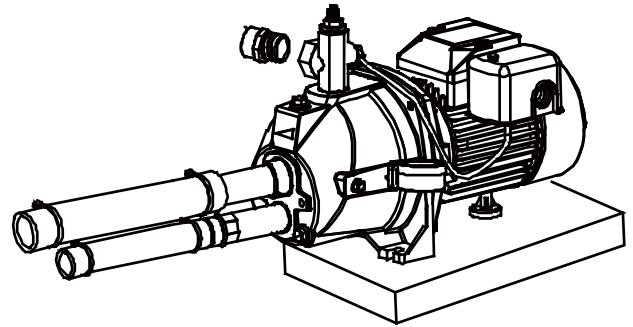

### 16 Connecting a tank tee to the pressure tank

- Wrap all threads with thread tape.
- In order for the pump and the pressure tank (sold separately) to operate properly, the pressure tank needs to be drained of all water **BEFORE INSTALLING IT TO THE PUMP**.
- Thread a 10 in. tank tee (sold separately) or another necessary size tee into the pressure tank.
- Plug one outlet on top of the tank tee with a 1/4 in. plug (sold separately) and install a pressure gauge (sold separately) on the other outlet on top of the tank tee.
- Thread two 1 in. female PVC adaptors (sold separately) onto the two inlet sides of tank tee.
- Thread a 1/2 in. relief valve and a 1/2 in. drain valve (both sold separately) to the front of the tank tee.

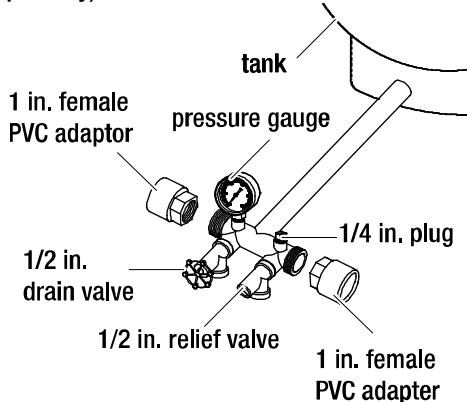

### 17 Checking the pressure in the tank

- Air pressure in the tank must be 2 psi lower than the "cut-in" of the pressure switch.



**NOTE:** The pump has a 30/50 psi pressure switch, which means the "cut-in" is 30 psi; therefore, the tank needs to be set to 28 psi. To check the pressure in the tank, use a tire pressure gauge (not included). If more air is needed, add air to the tank with a tire pump or air compressor. If less is needed, bleed out some air.

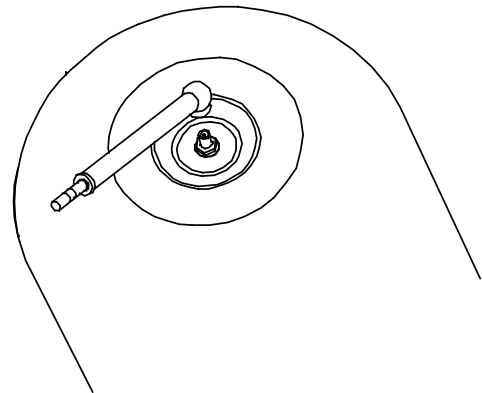

## Deep Well Installation (continued)

### 18 Connecting the pump with the water system



**CAUTION:** Never install a shut-off valve between the pump and the tank, as this can cause excessive friction loss and can damage the pressure switch and/or pump. If necessary, only install a fully open gate valve (sold separately).

- Using PVC purple primer and PVC cement, attach a section of 1 in. PVC pipe (sold separately) as needed to connect the 3/4 in. MNPT x 1 in. slip PVC adaptor in the pressure regulator.
- Attach another section of 1 in. PVC pipe (sold separately) as needed to connect the other 1 in. female PVC adaptor on the tank tee to the water system from the house.

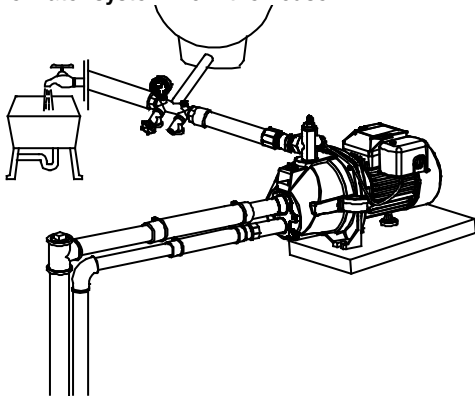

### 19 Voltage setting



**WARNING:** All electrical work should be performed by a licensed electrician.

- This pump is pre-wired at 230 volts.
- If the power source is 115 volts, remove the electrical housing cover.
- Flip the switch to 115 volts.
- Replace the cover.

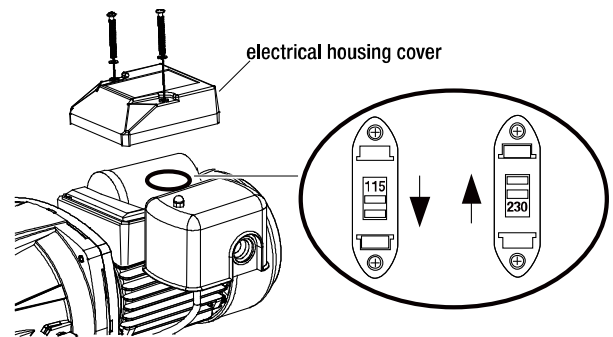

### 20 Setting pressure regulator

- Turn the regulator adjustment screw down tight.
- Turn on pump.
- If the pump is properly primed, a high pressure will immediately show on the pressure gauge.
- With the pump operating at high pressure, slowly unscrew the adjusting screw until maximum water flow is obtained without pressure dropping to zero.
- If pressure falls completely, retighten the screw and readjust it.
- If no pressure shows, stop the pump, remove the pressure regulator from pump, add more water, and try again.
- After the adjusted bolt is set up, lock the screw nut on the bolt.
- The pump is ready for use.



**NOTE:** The pressure regulator screw is very tight. A big screw driver needed.

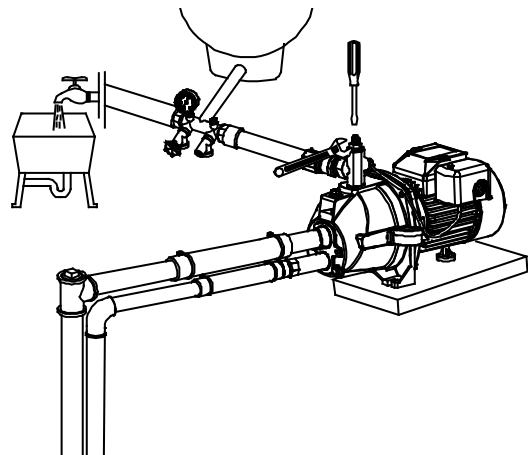

**Proceed to the Pressure Switch Assembly Instructions section on page 10 of this manual.**



# Troubleshooting

## Do

- Remove the drain plug (located on the front of the pump close to the inlet hole) and air plug (located on the top of the pump close to the outlet hole) to vent the system.
- Drain all piping to a point below the freeze line.



**NOTE:** While this will drain the pump, it will not necessarily drain all the unprotected parts of the piping system. To drain the tank, disconnect the piping at the tank outlet.

## Do Not

- Do not disassemble the motor housing. This motor has NO repairable internal parts, and disassembly may cause dangerous electrical wiring issues.

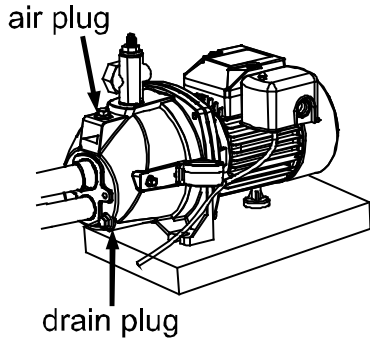

Problem	Possible Cause	Corrective Action
The pump does not start or run.	<ol style="list-style-type: none"> <li>1. The power is off.</li> <li>2. There is a blown fuse or tripped breaker.</li> <li>3. The pressure switch is faulty.</li> <li>4. The motor overload tripped.</li> <li>5. The wires are not connected correctly.</li> <li>6. The motor shaft stuck.</li> </ol>	<ol style="list-style-type: none"> <li>1. Turn the power on or call the power company.</li> <li>2. Replace the fuse or reset the circuit breaker.</li> <li>3. DISCONNECT THE POWER and then clean the switch contacts or replace the switch.</li> <li>4. Allow the pump to cool. Overload will automatically reset.</li> <li>5. Follow the instructions for wiring the pump.</li> <li>6. Please use a flat head screw driver to turn the motor shaft through the center hole on the motor cap. Then restart the pump.</li> </ol>
The pump does not prime.	<ol style="list-style-type: none"> <li>1. There is not enough water.</li> <li>2. Air is trapped in the pipe.</li> <li>3. The water level in the well is below the foot valve.</li> <li>4. The foot valve is plugged or leaks.</li> </ol>	<ol style="list-style-type: none"> <li>1. Stop the motor. Remove the pressure gauges or prime plug. Fill the housing pipes with water.</li> <li>2. Adjust the pump's height so that the pipe slopes away from the pump.</li> <li>3. Lower the suction pipe. If the water level is more than 25 ft., you need a deep well pump.</li> <li>4. Replace the foot valve or dig the well deeper.</li> </ol>

## Troubleshooting(continued)

Problem	Possible Cause	Corrective Action
The pump operates but pumps little or no water.	<ol style="list-style-type: none"> <li>1. The water level is below the pump intake.</li> <li>2. The discharge was not vented while priming.</li> <li>3. There is a leak in the piping on the well side of the pump.</li> <li>4. The well screen or inlet strainer is clogged.</li> <li>5. The foot valve may be clogged or stuck closed.</li> <li>6. The pump is not fully primed.</li> <li>7. The water level is below the maximum lift specification.</li> <li>8. The piping is undersized.</li> <li>9. The voltage is not correct.</li> </ol>	<ol style="list-style-type: none"> <li>1. Lower the suction pipe further into the well.</li> <li>2. Open the faucet and repeat the priming procedure.</li> <li>3. Repair the piping as needed.</li> <li>4. Clean or replace as necessary.</li> <li>5. Clean or replace as necessary.</li> <li>6. Follow the priming instructions.</li> <li>7. Return the pump and purchase a deep well jet pump.</li> <li>8. Increase the pipe size to a min. 1-1/4 in..</li> <li>9. Check the voltage switch.</li> </ol>
The pump starts and stops too often.	<ol style="list-style-type: none"> <li>1. The incorrect tank was pre-charged.</li> <li>2. There is a ruptured diaphragm/bladder (pre-charged tank).</li> <li>3. There is a leak in the house piping.</li> <li>4. The foot or check valve is stuck open.</li> <li>5. The pressure switch does not match the tank pressure.</li> </ol>	<ol style="list-style-type: none"> <li>1. Empty water from the tank. Add or release air as needed to reach 28 psi.</li> <li>2. Replace the tank.</li> <li>3. Locate and repair the leak or reconnect.</li> <li>4. Remove and replace.</li> <li>5. Readjust or replace the switch. Call customer service.</li> </ol>
The pump does not shut off.	<ol style="list-style-type: none"> <li>1. There is a leak in the house piping.</li> <li>2. The water level is lower than the estimate.</li> <li>3. The pressure switch is not properly set.</li> </ol>	<ol style="list-style-type: none"> <li>1. Locate and repair (usually a leaky toilet or faucet).</li> <li>2. Use a deep well jet pump if the water level is greater than 25 ft.</li> <li>3. Reset or replace the pressure switch.</li> </ol>



Questions, problems, missing parts? Before returning to the store call  
Everbilt Customer Service  
8 a.m. - 6 p.m., EST, Monday-Friday

**1-844-241-5521**

**[WWW.HOMEDEPOT.COM](http://WWW.HOMEDEPOT.COM)**