

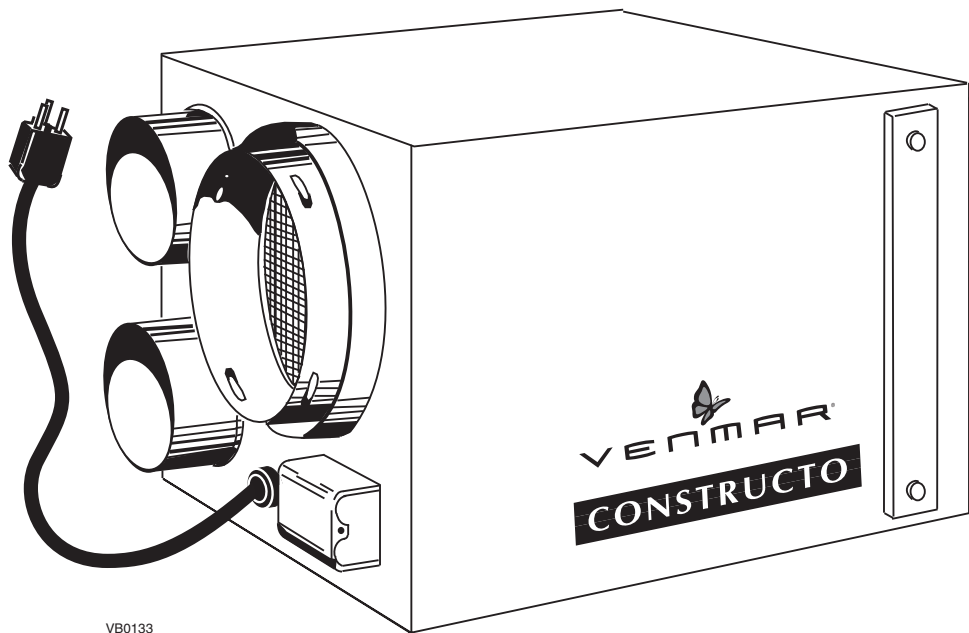

CONSTRUCTO AIR EXCHANGER

Venmar Constructo Air Exchanger Part no. 41000



A BASIC VENTILATION SYSTEM, ECONOMIC AND ROBUST, THAT CONTROLS EXCESS HUMIDITY. IDEAL FOR BUNGALOWS OR SMALL SURFACE AREAS.

- Air exchange with outdoors. Exhausts stale air out and brings fresh air in.
- Controls the excess humidity level in the house.
- Mechanical air filtration by a washable filter.
- 6"Ø (15.54 cm Ø) ambient air intake and air outlet to facilitate installation in new houses.
- Plug-in module, simplifying the installation.
- Dehumidistat wall control (120 V).
- Complete two-year warranty on parts.

Available at:

Dimensions

- Dimensions: 18¼" x 12¼" x 15"
(46.4 cm x 31.1 cm x 38.1 cm).
- Weight: 40 lb. (18 kg)
- Electrical characteristics:
 - Voltage: 120 V
 - Power: 200 watts
 - Amperage: 3.0 amperes

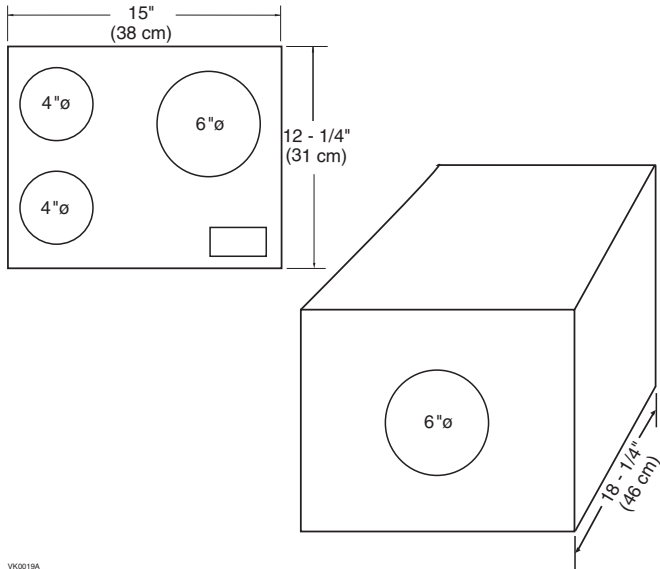

VK0019A

Air flow while exchanging

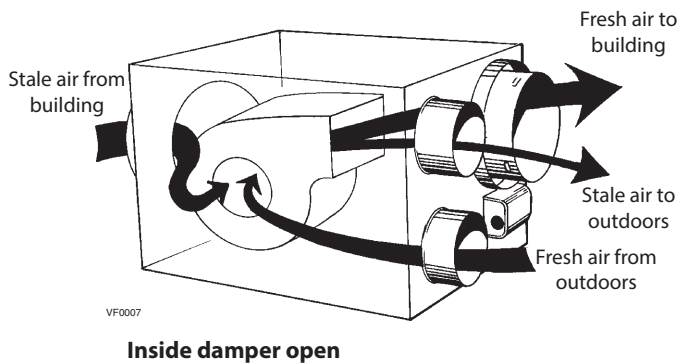

VF0007

Project:	REMARKS
Location:	
Part Number: 41000	
Quantity:	
Submitted by: _____ Date: _____	

Installation

BASEMENT INSTALLATION MODEL

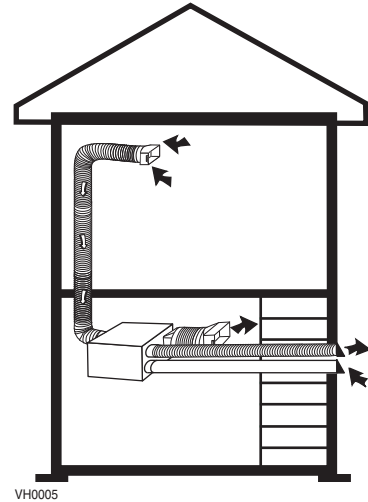

VH0005

Ventilation rates

- Fresh air intake: 60 cfm (30 l/s)
- Stale air exhaust: 80 cfm (40 l/s)
- Circulation rate: 250 cfm (125 l/s)

Warranty

Venmar Constructo air exchangers are covered by a full, two-year warranty on all parts or manufacturing defects which may affect the operation of the unit. The warranty applies where the damage is not the result of poor installation, improper use, mistreatment, negligence, act of God, or any other circumstance beyond the control of Venmar Ventilation ULC.



Residential Product Group, 550 Lemire Blvd., Drummondville, Qc, Canada J2C 7W9 - Tel.: 1-800-67-3855 Fax: 1-800-567-1715



www.venmar.ca

90335 (14_12)