

Installation Instructions

ROLL VENT®

STANDARD / METRIC

	Page
Installation Considerations	3
Roll Vent Standard General Installation	4
Roll Vent Metric General Installation	5
Steep Pitch Guidelines	6
Asphalt Shingles Detail	7
Ridge Beam Detail	8
Hip Roof Detail	9
Shed Roof Detail	10
Standing Seam Detail	10
Off Peak Detail	11
Cathedral Ceilings Detail	12
No-Slot Vent Detail	13
Fascia Vent & Drip Edge Vent Detail	14



ROLL VENT®

**C O N T I N U O U S
R I D G E V E N T**

Installation Considerations

DO NOT use multiple vent systems such as:

- Powered Fans
- Roof Pots
- Turbines
- Gable Vents

If continuous soffit or fascia vents and ridge vents are used, other vent systems should be removed or disconnected and gable vents should be closed. The use of mixed ventilation systems, such as soffit and ridge vents in combination with a power fan could result in reverse airflow that could result in water leakage into the attic.

Roll Vent Standard General Installation

Requirements:

- Install on pitches 3/12 to 18/12. See page 4 for pitches greater than 12/12.
- Must be used with an equal or greater amount of soffit vent.
- 3 1/2 inch slot required at ridge.
- Must be installed with minimum nail size of 2 1/2 inches.
- If installing on dimensional or architectural shingles on new construction, leave felt underlayment about 6 inches long at roof ridge and fold back under the vent. The vent should be installed on top of the felt over the shingles. If re-roofing, caulk between low areas of shingle and underside of ridge vent.

Step 1:

Snap chalk line and cut a slot 3 1/2 inches wide (1 3/4 inch on each side of ridge beam). Allow for a closed area of sheathing 18 inches at both ends of ridge.

Step 2:

No end cap is necessary if cap shingles are lapped over end of product and down onto ridge. In this case, run vent to 12 inches from gable ends. Cap shingles can be laid down over end of vent onto ridge out to gable ends. Optionally, Roll Vent can be installed right to gable ends using an integral end cap. To create end cap, loosen about 6 inches of matrix from fabric and cut out with snips. Fold bottom fabric in toward center of product so that it covers the end of vent. Start and end vent installation 1 inch from gable ends.

Step 3:

Center vent over slot at one end with printed logo side “up” and fasten with two nails (note: minimum nail length is 2 1/2 inches). Roll out along entire ridge, pull out slack, and fasten with two nails at opposite end (creating end cap at other end if using that method). Center cap shingles over vent and install with 2 1/2 inch nails provided. Use nail line as placement guide. If using fabric end cap, hang shingles 1 inch over vent at gable ends. Nails must penetrate into sheathing 3/4 inch or completely through the sheathing.

Step 4:

To splice, remove about 3 inches of matrix from fabric and lay end of new roll inside remaining fabric to create fabric overlap.

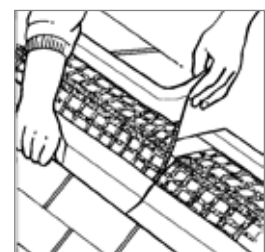
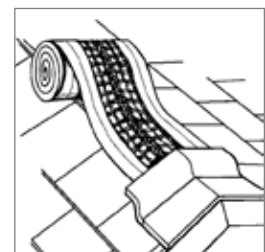
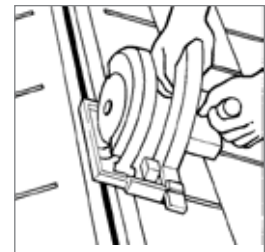

Roll Vent Metric General Installation

Requirements:

- Install on pitches 3/12 to 18/12. See page 4 for pitches greater than 12/12.
- Must be used with an equal or greater amount of soffit vent.
- 3 1/2 inch slot required at ridge.
- Must be installed with minimum nail size of 2 1/2 inches (6.4 cm).
- If installing on dimensional or architectural shingles on new construction, leave felt underlayment about 6 inches long at roof ridge and fold back under the vent. The vent should be installed on top of the felt over the shingles. If re-roofing, caulk between low areas of shingle and underside of ridge vent.

Step 1:

Snap chalk line and cut slot 3 1/2 inches (8.9 cm) wide (1 3/4 inches {4.4 cm} on each side of ridge beam). Allow for a closed area of sheathing 18 inches (46 cm) at both ends of the ridge.

Step 2:

No end cap is necessary if cap shingles are lapped over end of product and down onto ridge. In this case, run vent to 12 inches (30 cm) from the gable ends. Cap shingles can be laid down over end of vent onto ridge and out to gable ends. Optionally, Roll Vent can be installed right to gable ends using an integral end cap. To create end cap, loosen about 6 inches (16 cm) of matrix from fabric and cut out with snips. Fold bottom fabric in toward center of product so that it covers the end of vent. Start and end vent installation 1 inch (2.5 cm) from gable ends.

Step 3:

Center vent over slot at one end with printed logo side “up” and fasten with two nails (note: minimum nail length is 2 1/2 inches {6.4 cm}). Roll out along entire ridge, pull out slack, and fasten with two nails at opposite end (creating end cap at other end if using that method). Center cap shingles over vent and install with 2 1/2 inch (6.4 cm) collated nails provided. Use nail line as placement guide. If using fabric end cap, hang shingles 1 inch (2.5 cm) over vent at gable ends. Nails must penetrate into sheathing 3/4 inch (1.9 cm) or completely through the sheathing.

Step 4:

To splice, remove about 3 inches (7.6 cm) of matrix from fabric and lay end of new roll inside remaining fabric to create fabric overlap.

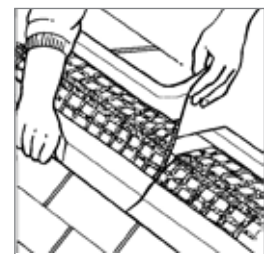
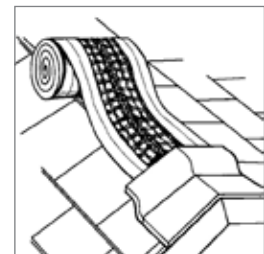
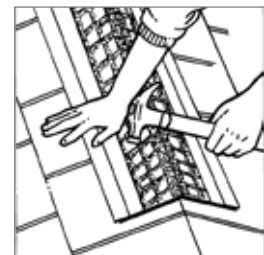
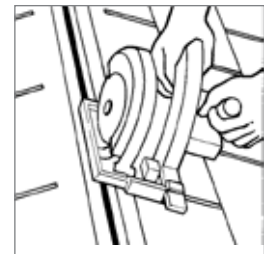

Steep Pitch Guidelines (**Standard, Metric**)

As a roof's pitch becomes steeper, the effective opening of the slot becomes smaller. To provide effective ventilation, the sheathing cut must be wider than normal.

CAUTION: on steep pitch roof conditions verify proper clearance from edge of sheathing prior to nailing.

The following chart gives the necessary measurements for steeper than 12/12 pitches:

PITCH	EACH SIDE (Standard, Metric)
13/12	2 5/8 in *(5 1/4 in total)
14/12	2 3/4 in *(5 1/2 in total)
15/12	2 7/8 in *(5 3/4 in total)
16/12	3 in *(6 in total)
17/12	3 1/8 in *(6 1/4 in total)
18/12	3 1/4 in *(6 1/2 in total)

Under no circumstances should Roll Vent be installed on pitches greater than 18/12.

The presence of a ridge beam may slightly reduce ventilation.

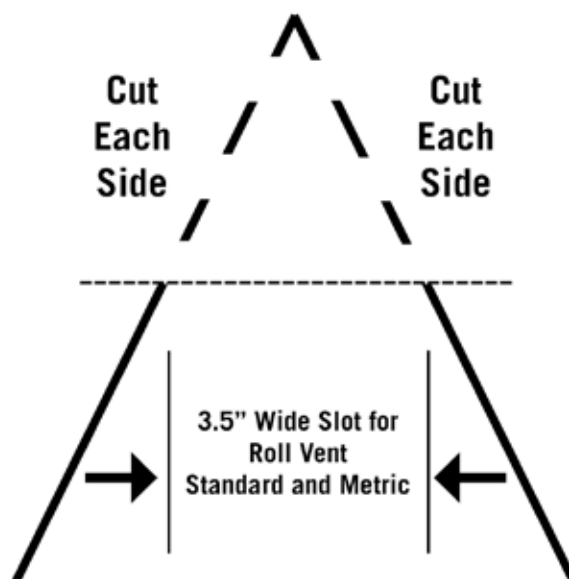

Asphalt Shingles Detail (Standard, Metric)

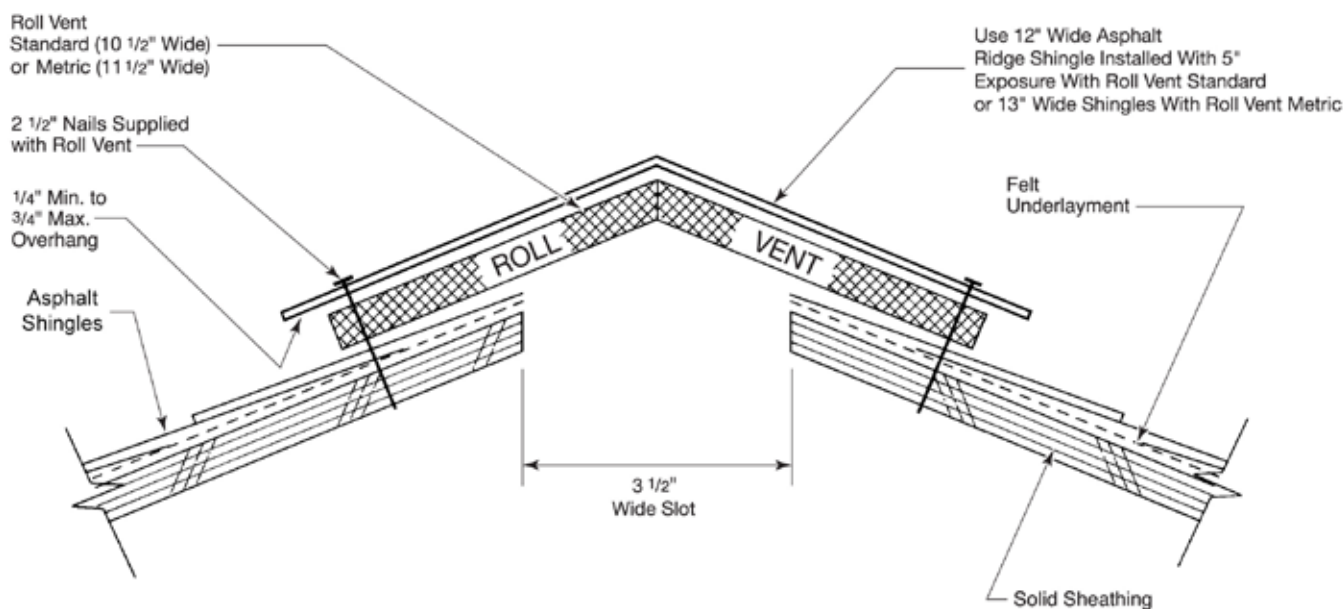

Note:

Install with continuous soffit ventilation at each eave equivalent to 9 sq. in. per linear foot. Installs on pitches 3/12 to 18/12. For pitches greater than 12/12, refer to page 4.

Use Roll Vent Standard (10 1/2 inches) for 12 inch cap shingles. Use Roll Vent Metric (11 1/2 inches) for metric shingles approximately 13 inches wide. If installing on dimensional or architectural shingles on new construction, leave felt underlayment about 6 inches long at roof ridge and fold back under the vent so that vent is essentially installed on top of felt over the shingles. If re-roofing, caulk between low areas of shingle and vent after installation.

1. Snap chalk line and cut slot 3 1/2 inches wide (1 3/4 inches on each side of ridge beam). Allow for a closed area of sheathing 18 inches at both ends of the ridge.

2. No end cap is necessary if cap shingles are lapped over end of product and down onto ridge. In this case, run vent to 12 inches from the gable ends. Cap shingles can be laid down over end of vent onto ridge and out to gable ends. Optionally, Roll Vent can be installed

right to gable ends using an integral end cap. To create end cap, loosen about 6 inches of matrix from fabric and cut out with snips. Fold bottom fabric in toward center of product so that it covers the end of vent. Start and end vent installation 1 inch from gable ends.

3. Center vent over slot at one end with printed logo side "up" and fasten with two nails (note: minimum nail length is 2 1/2 inches). Roll out along entire ridge, pull out slack, and fasten with two nails at opposite end (creating end cap at other end if using that method). Center cap shingles over vent and install with 2 1/2 inch nails provided. Use nail line as placement guide. If using fabric end cap, hang shingles 1 inch over vent at gable ends. Nails must penetrate 3/4 inch into sheathing or completely through the sheathing.

4. To splice, remove about 3 inches of matrix from fabric and lay end of new roll inside remaining fabric to create fabric overlap.

Ridge Beam Detail (Standard, Metric)

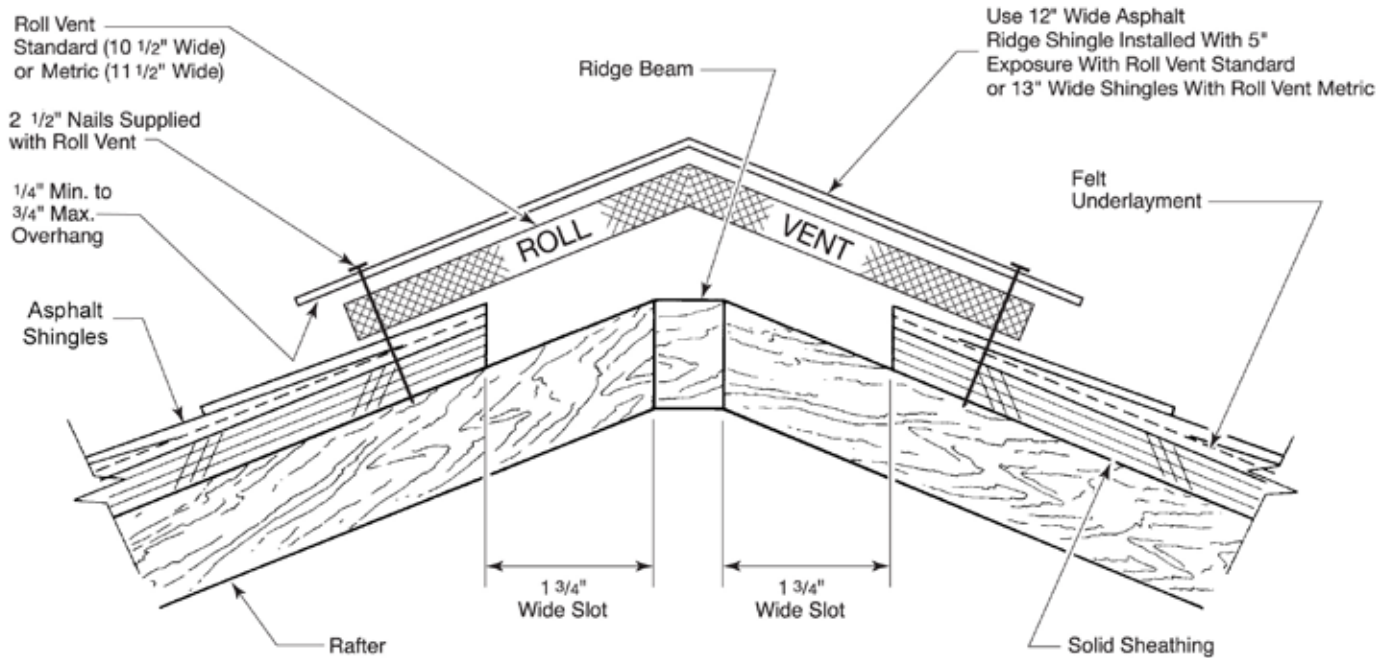

Note:

If ridge beam is wider than 2 inches, refer to Roll Vent Off Peak Installation.

Install with continuous soffit ventilation at each eave equivalent to 9 sq. in. per linear foot. Installs on pitches 3/12 to 18/12. For pitches greater than 12/12, refer to page 4. Use Roll Vent Standard (10 1/2 inches) for 12 inch cap shingles. Use Roll Vent Metric (11 1/2 inches) for metric shingles approximately 13 inches wide. If installing on dimensional or architectural shingles on new construction, leave felt underlayment about 6 inches long at roof ridge and fold back under the vent so that vent is essentially installed on top of felt over the shingles.

If re-roofing, caulk between low areas of shingle and vent after installation.

1. Snap chalk line and cut a slot 1 3/4 inches on each side of ridge beam. Allow for a closed area of sheathing with no slot 18 inches at both ends of ridge.

2. No end cap is necessary if cap shingles are lapped over end of product and down onto ridge. In this case, run vent to 12 inches from gable ends. Cap shingles

can be laid down over end of vent onto ridge and out of gable ends. Optionally, Roll Vent can be installed right to gable ends using an integral end cap. To create end cap, loosen about 6 inches of matrix from fabric and cut out with snips. Fold bottom fabric in toward center of product so that it covers the end of vent. Start and end vent installation 1 inch from gable ends.

3. Center vent over slot at one end with printed logo side "up" and fasten with two nails (note: minimum nail length is 2 1/2 inches). Roll out along entire ridge, pull out slack, and fasten with two nails at opposite end (creating end cap at other end if using that method). Center cap shingles over vent and install with 2 1/2 inch nails provided. Use nail line as placement guide. If using fabric end cap, hang shingles 1 inch over vent at gable ends. Nails must penetrate 3/4 inch into sheathing or completely through the sheathing.

4. To splice, remove about 3 inches of matrix from fabric and lay end of new roll inside remaining fabric to create fabric overlap.

Hip Roof Detail (Standard, Metric)

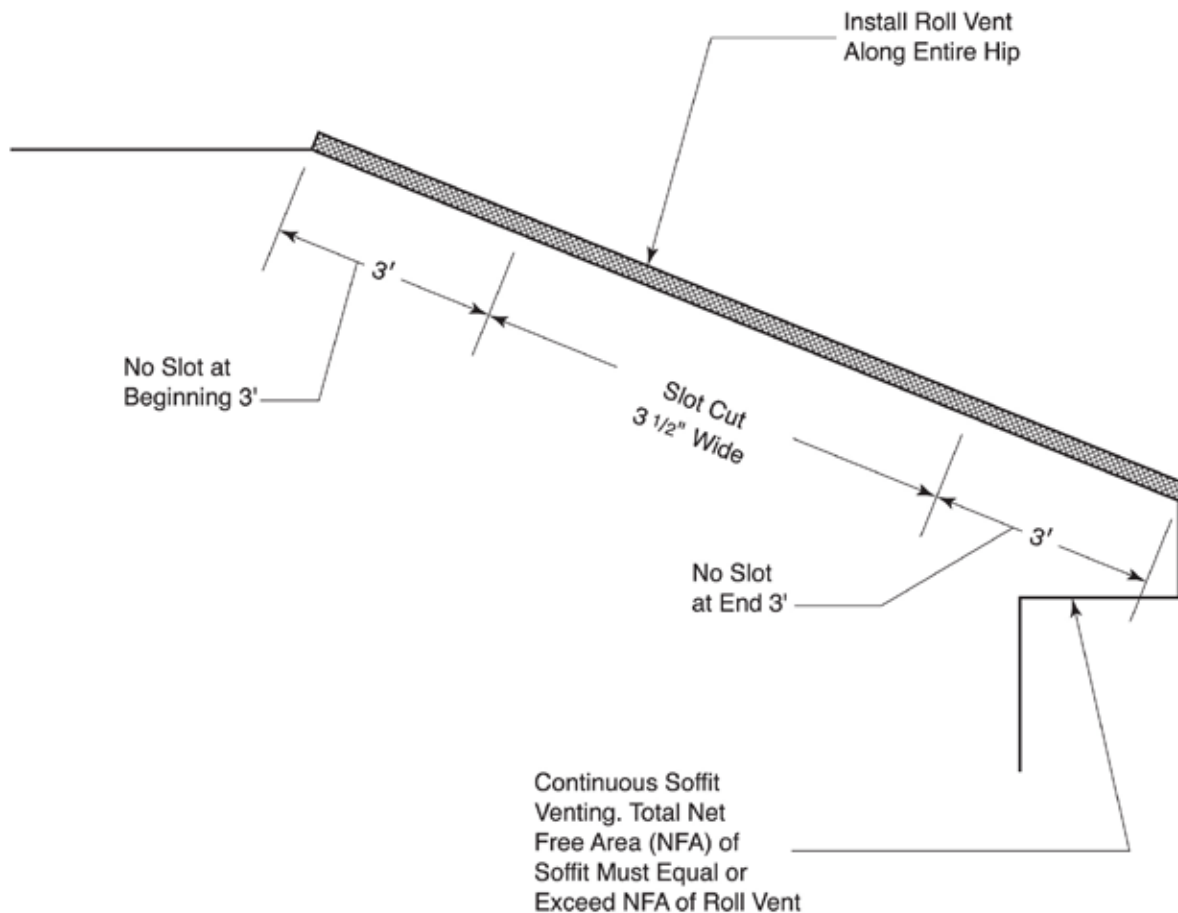

Note:

Hip Application not to exceed 12/12 pitch.

Cut slot in roof along hip 3 1/2 inches wide beginning 3' from peak and running to 3 feet of end of hip. Start Roll Vent a minimum of 1 inch from each end of the hip using end cap installation (pg 2). Center cap shingles over vent and use nail line as a placement guide. Install with 2 1/2 inch nails provided. Nails must penetrate into the sheathing 3/4 inch or completely through the sheathing. Cap shingles must overhang Roll Vent by 1 inch each hip end.

Run bead of sealant along bottom edge of Roll Vent where it meets shingles on roof deck. Hip application is for Roll Vent Standard (10 1/2 inches) or Roll Vent Metric (11 1/2 inches).

Shed Roof Detail (Standard, Metric)

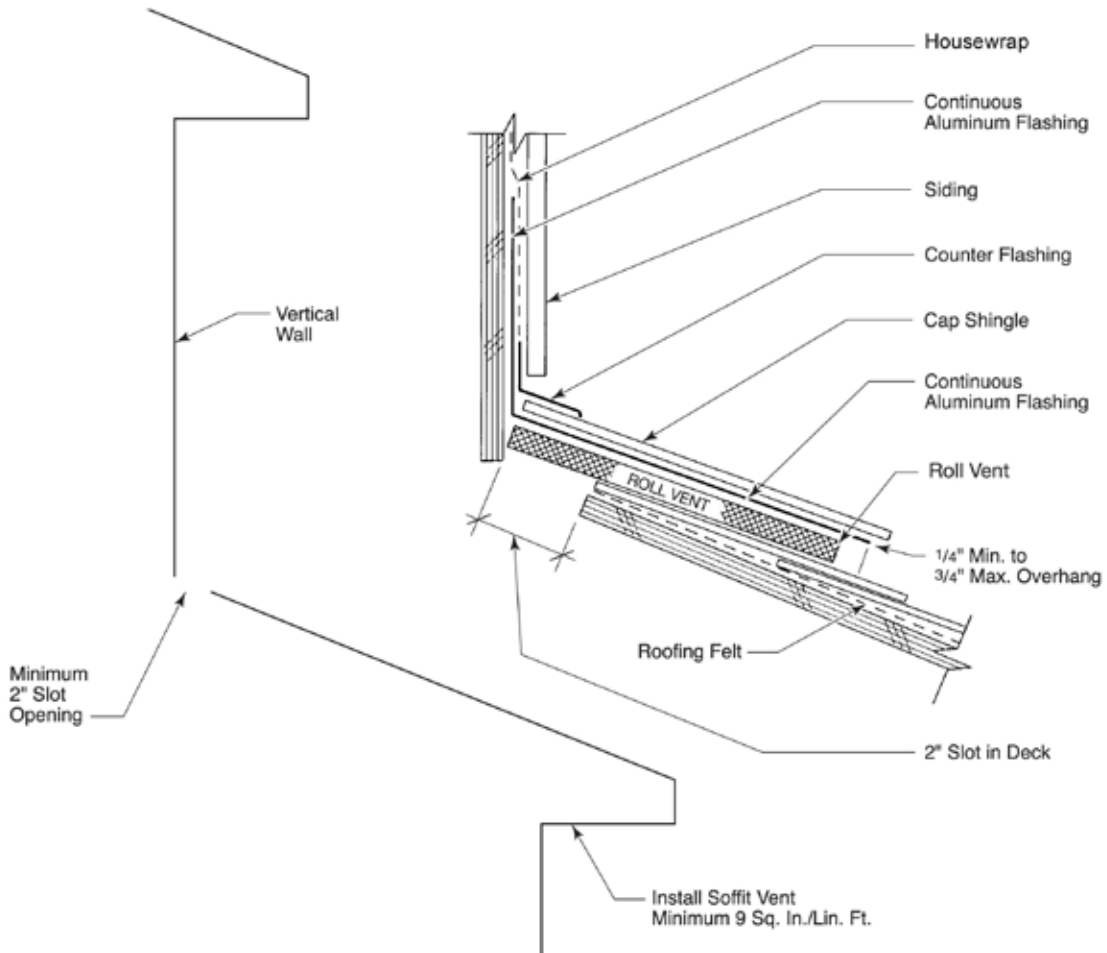

Note:

Roll Vent will only vent 9 sq. in. per linear foot in this application. The Venturi effect will be limited.

Start Roll Vent a minimum of 1 inch from each end of roof using the end cap installation (pg 5). Center cap shingles over vent and install with nails provided. Use nail line as placement guide. Nails must penetrate into the sheathing 3/4 inch or completely through the sheathing. Cap shingles must overhang Roll Vent by 1 inch minimum at each end of roof.

For added weather protection, install counter flashing behind siding and over top of cap shingle.

Standing Seam Detail (Standard, Metric)

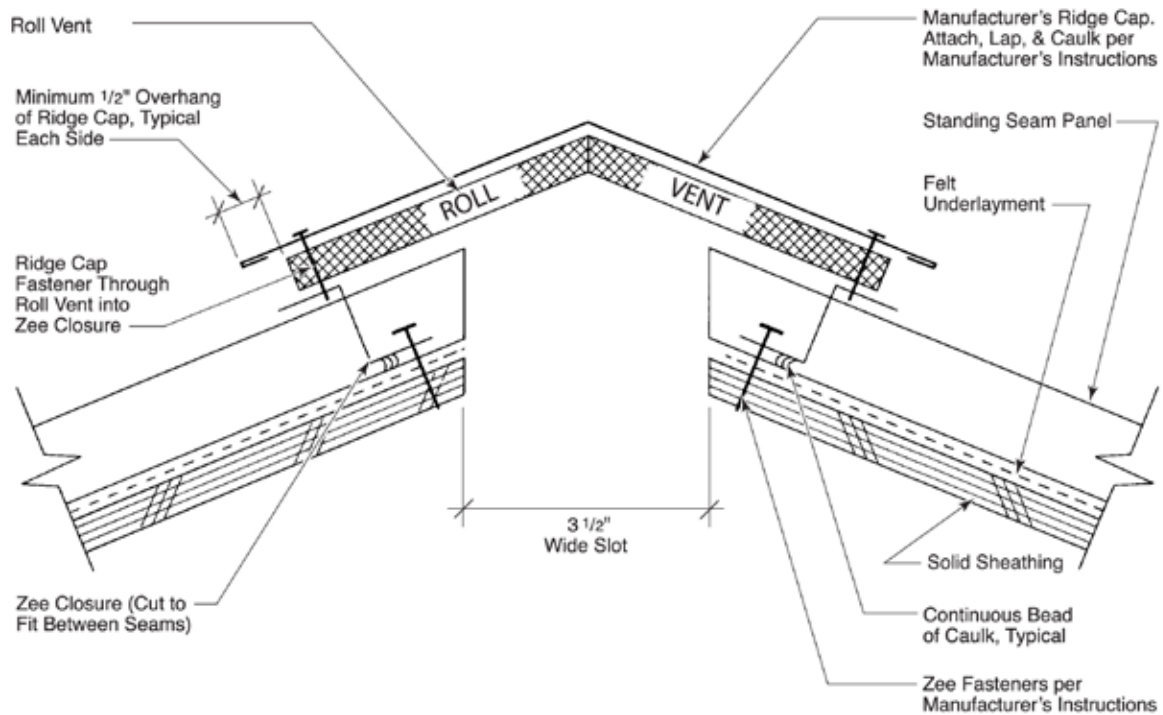

Note:

Install with continuous soffit ventilation at each eave equivalent to 7 sq. in. per linear foot.

Roll Vent available in Standard (10 1/2 inches) and Metric (11 1/2 inches) widths. Choose width that will allow ridge cap to overhang Roll Vent by 1/2 inch minimum on each side.

Off Peak Detail (Standard, Metric)

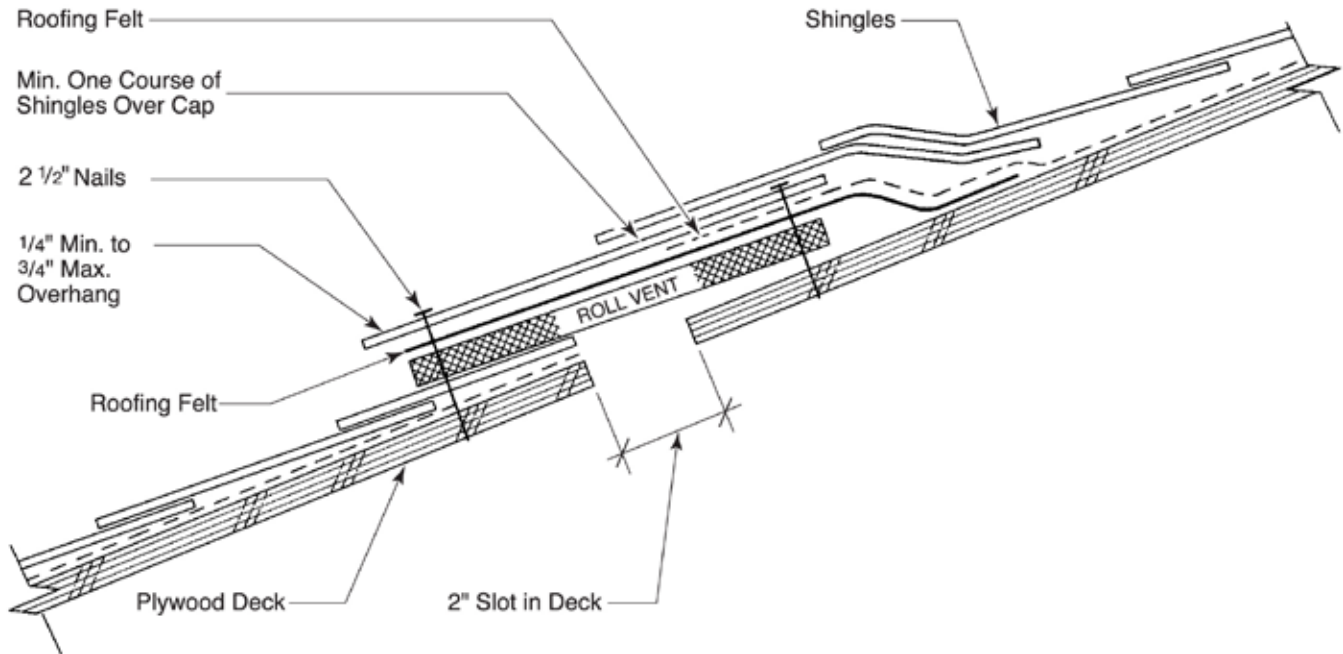

Note:

Roll Vent will only vent 9 sq. in. per linear foot in this application and must be installed with a soffit vent with a minimum of 9 sq. in. per linear foot net free area. It is recommended that Roll Vent and soffit vent be installed on both sides of the peak.

1. Cut 2 inches wide slot in deck no more than 4 feet from ridge and no closer than 4 feet from eave. Allow for closed area of sheathing with no slot approximately 6 inches at both ends.
2. Install felt per manufacturer's instructions onto deck leaving slot exposed. Do not nail or staple through felt within 8 inches of slot opening on high side of slot.
3. Shingle per manufacturer's instructions up to slot.
4. Center Roll Vent over slot, tack down at end and roll out. Start Roll Vent a minimum of 1 inch from each end of roof using the end cap installation (pg 5).

5. Install minimum 14 inches wide felt on top of Roll Vent and lap felt from deck on top of this course of felt.
6. Install one-tab cap shingles over felt and Roll Vent with 2 1/2 inch nails provided. Nail approximately 2 1/2 inches in from cap shingle edge on nailing rib indicated by nailing line. Nails must penetrate into the sheathing 3/4 inch or completely through the sheathing. Cap shingles must overhang Roll Vent by 1 inch at each gable end. Cap shingles should overhang Roll Vent by 1/4 inch minimum to 3/4 inch maximum on each side. Cap shingles can be used as this course provided 2 1/2 inch nails are placed on each tab 1 inch from lower edge of Roll Vent and nail heads are sealed in caulk.
7. Install minimum one course of shingles lapped on top of cap. Install rest of shingles per manufacturer's instructions.

Cathedral Ceilings (**Standard, Metric**)

Cathedral or vaulted ceilings present some unique ventilating situations that need to be addressed up front to avoid condensation problems down the road. A cathedral ceiling is typically constructed utilizing 2 x 8 rafters on 16 inch or 24 inch centers; plywood roof decking on top of the rafters; and drywall, which

becomes the ceiling of the room below, on the bottom of the rafters. Since this rafter space becomes the only separation between living space and outside temperatures, many builders want to install as much insulation as possible in this space. This causes a problem by restricting the air flow capability from soffit (intake) to ridge (exhaust) within these rafter spaces. This usually shows up in the form of condensation. The following are tips to follow when designing or installing Roll Vent for use in cathedral/vaulted ceilings:

- 1.** Be sure to properly “balance” the Roll Vent total net free area with soffit vent total net free area. Strip soffit vent with a net free area of at least 9 sq. in. per linear foot is necessary.
- 2.** Install Roll Vent and soffit venting continuously along the ridge and eave overhang, respectively. Each rafter space must have air flow.
- 3.** Install “vent chutes” between the rafters from the soffit to the ridge. This assures at least 1 1/2 inches of unobstructed air space between the bottom of the deck and top of the insulation.
- 4.** Install a vapor barrier on the “warm” side of the insulation to provide a block against living area moisture migrating into the rafter spaces. Following the above procedures will minimize the potential for condensation-related problems in cathedral or vaulted ceilings.

No-Slot Vent Detail (Standard, Metric)

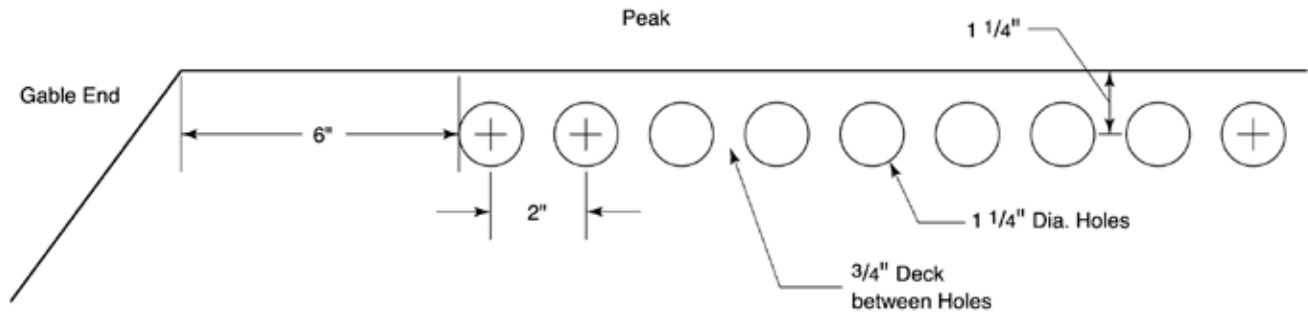

In certain areas of the United States, building codes do not allow for a continuous slot to be cut into the roof structure. This is especially true on the west coast and other earthquake prone areas. Roll Vent can be installed on a roof without a continuous slot.

Drill 1 1/4 inch holes every 2 inches on center (this will leave 3/4 inch of deck between each hole) and 1 1/4 inches on center from the peak of the roof. From each gable end, leave 6 inches with no holes cut.

This installation will work with/without the presence of a 2X ridge beam. Roll Vent will vent 6.1 sq. in. per linear foot in this application.

Fascia Vent & Drip Edge Vent Detail (Standard, Metric)

FASCIA VENT APPLICATION

1. Trim Roll Vent with utility knife to appropriate width to fit behind fascia board.
2. Install flush with bottom of fascia. Position fabric side outwards toward open air to prevent insect infiltration.
3. Roll Vent will provide 9 sq. in. of net free area per linear foot in this application.

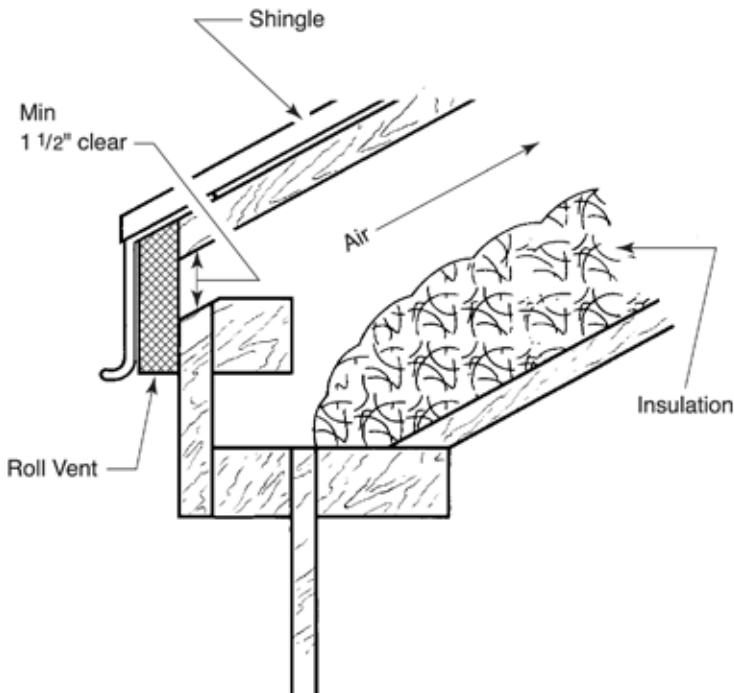
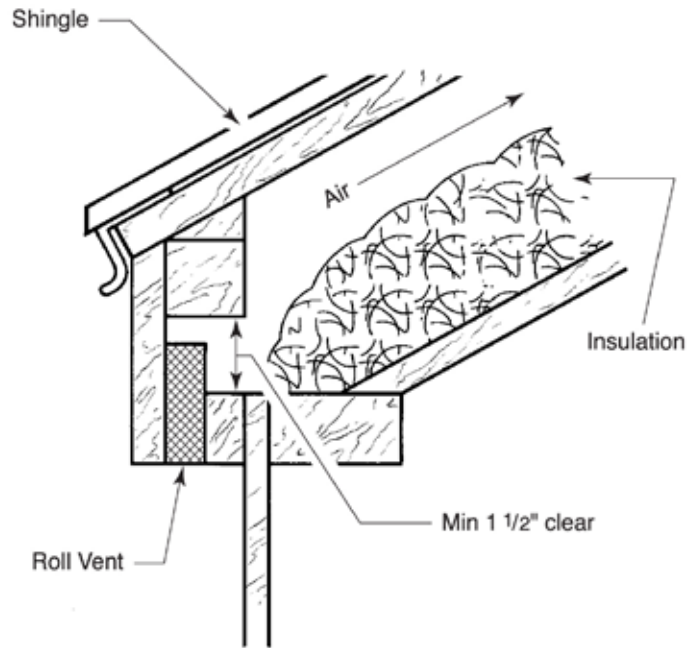

DRIP EDGE VENT APPLICATION

1. Trim Roll Vent with utility knife to appropriate width to fit under drip edge.
2. Install flush with bottom of drip edge. Position fabric side outwards toward open air to prevent insect infiltration.
3. Roll Vent will provide 9 sq. in. of net free area per linear foot in this application.

Note: Roll Vent is available in Standard (10 1/2 inches), and Metric (11 1/2 inches) widths. Please specify application requirements when ordering.