

U. S. FOREST SERVICE
RESEARCH PAPER
FPL 47
OCTOBER 1965

CLICK HERE TO RETURN TO
ASBESTOS IN FIBERBOARD SHEATHING INFORMATION
at InspectApedia.com

U. S. DEPARTMENT OF AGRICULTURE
FOREST PRODUCTS LABORATORY

FOREST SERVICE
MADISON, WIS.

DEVELOPMENT OF AN IMPROVED SYSTEM OF WOOD-FRAME HOUSE CONSTRUCTION

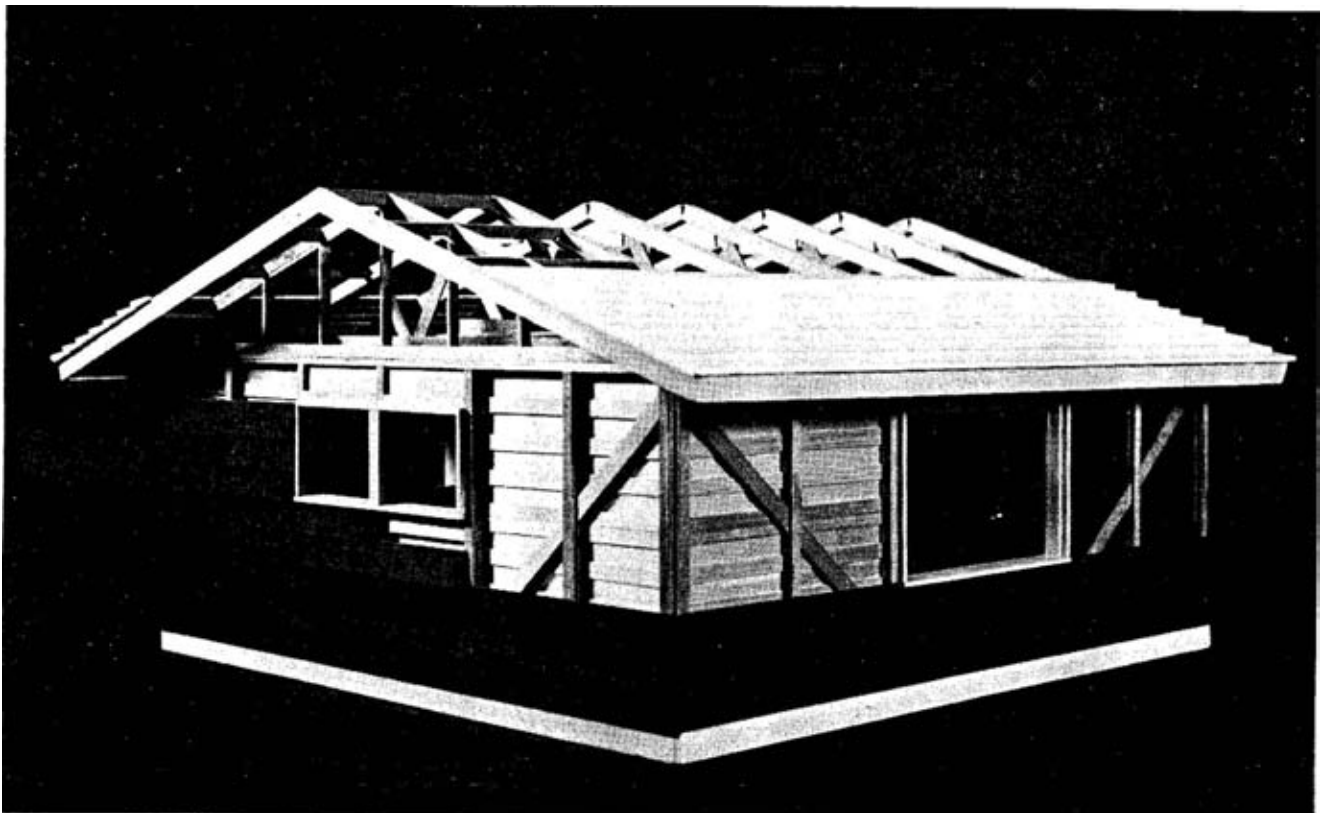

SUMMARY

A new system of wood-frame house construction has been developed which combines increased use of low-grade wood, prefinished components, and rapid field assembly methods without much divergence from conventional construction. Laboratory evaluations of the components of the Nu-frame system indicated that;

(a) 4-foot spacing of the W-trusses tested provides a safety factor of three over design load,

(b) the wall framing system with 4-foot spacing of double 2- by 4-inch studs (Nu-frame) is a reasonable method of construction,

(c) the use of a 1/2-inch fiberboard filler between studs (Insul-2) provides racking resistance as well as adequate thermal and sound insulation,

(d) the interior finish (Perm-board) has greater stiffness and strength over a 48-inch span than 3/8-inch gypsum board over a 16-inch span, and

(e) the prefinished roof covering (Plastic-plank) provides excellent resistance to moisture entry.

The use of both mechanical fasteners and adhesives assures rapid on-the-job assembly of framing and covering materials and low site-labor costs. This laboratory evaluation will be followed by construction of an experimental unit for further study.

DEVELOPMENT OF AN IMPROVED SYSTEM OF WOOD-FRAME HOUSE CONSTRUCTION

by L. O. Anderson, Engineer

FOREST PRODUCTS LABORATORY~
FOREST SERVICE
U. S. DEPARTMENT OF AGRICULTURE

INTRODUCTION

Construction methods for wood-frame houses have changed very little during the past 50 years or more. The changes in framing or sheathing systems that have occurred usually resulted in the use of less wood. Substitute materials have made large gains during the last few decades and have resulted in the use of several thousand fewer board feet of lumber in today's house. In addition, the use of sheet materials for subfloors and wall and roof sheathing has resulted in a surplus of 1-inch boards in the lower softwood grades. Except for special processing, there is little use for such material in the present-day wood-frame house.

In order to effectively use some of the lower grade wood products, increase the use of wood in each house, and reduce the overall cost, it was necessary to develop some new type of con-

struction system. However, such a system must generally comply with local building regulations as well as be acceptable to the carpenter and other craftsmen. Thus, it was important that materials and general assembly methods remain somewhat conventional.

A new system of construction consisting of six wood or wood product components was developed at the Forest Products Laboratory. The materials used and the assembly methods adopted generally comply with the requirements a new system must meet to be acceptable. The following sections include descriptions of the various components and the laboratory evaluations and outdoor exposures which were conducted. The results of this analysis have indicated that a full-size experimental unit should be constructed for further study.

¹Maintained at Madison, Wis., in cooperation with the University of Wisconsin

DESCRIPTION OF COMPONENTS

Initial development of a new framing system, "Nu-frame," and its various components covered a period of more than a year. It began by the evolution of a laminated siding-sheathing material. This prefinished covering material was capable of spanning 4 feet because of its thickness, and thus the new wall framing system and later the roof system were based on 4-foot spacing of the frame members. Interior covering and prefinished roof planking were further developments which included all main house components except the floor and floor framing. Consequently, this method can be used for houses constructed over concrete slabs, crawl spaces, or basements.

At present, there are five major parts in the system plus a sixth acoustical and thermal insulating sheet material which can be used in interior or exterior walls.

Wall Framing

All wall framing members: of the Nu-frame system including studs, plates, and headers, are based on 1-1/2- by 3-5/8-inch members. Although exact dimensions are not critical, a constant thickness is desirable.

The wall framing consists of double studs with 4-foot spacing. Studs are placed with wide faces in the plane of the wall, and nailed so that faces are flush with the edges of top and bottom plates, figure 1. A space of 1/2 to 5/8 inch between inner and outer studs allows for diagonal bracing, header web combinations over window and door openings, or the 1/2-inch-thick acoustical sheet material. The top or connecting plates may be nominal 1 by 4 or 2 by 4 random length members. Plate splices are made at the studs.

Headers over door and window openings consist

Figure 1.--Detail of Nu-frame wall framing system.

M 129 529

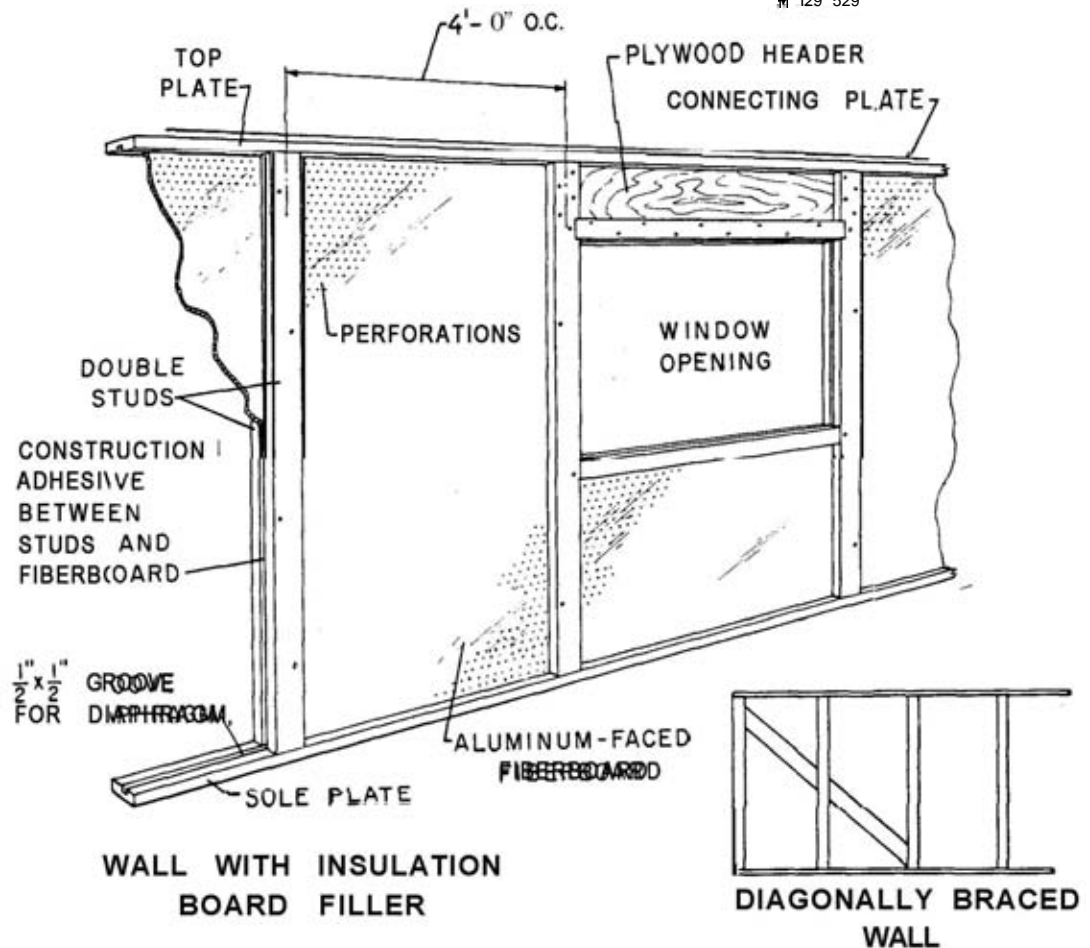

of a 1/2- or a 5/8-inch-thick plywood web member placed between the studs above the opening. Nominal 2- by 4-inch members are placed in prenotched studs and nailed to the bottom edge of the plywood web. This forms the flange and provides added stiffness and strength to the header, figure 2. The 2- by 4-inch members also provide nailing surfaces for window and door frames and exterior and interior covering materials. For wide openings a slotted top plate or double 2- by 4-inch members will assure adequate stiffness and strength.

Corner bracing of 5/8- by 6-inch or wider boards is used in one system of framing, figure 1. The boards are inserted between studs and fastened by nailing through the studs and the brace with twelpenny nails. The second method of providing rigidity to the wall has more promise as it also incorporates acoustical and thermal insulation, figure 1. This new type of material, "Insul-2," is basically 1/2-inch fiberboard in 4- by 8-foot. sheets. Each face is covered with an aluminum foil which provides reflective insulation

with a total resistance equal to about 1-1/2 inches of flexible insulation. Each side of the sheet material has punched holes 3/16 inch deep which allow passage of water vapor and also provide sound absorption qualities, figure 3.

Assembly of the new wall framing is accomplished with nails and a construction adhesive applied by means of a caulking gun. The inner studs are placed in a flat position and nailed to top and bottom plates. Plywood headers are nailed in place at doors and windows and the acoustic fiberboard (Insul-2) placed vertically over a ribbon of adhesive. The top or outer studs are then fastened to the plates and to the studs beneath, after adhesive has been applied to the Insul-2.

Roof Framing

Roof framing consists of special wood trusses spaced 4 feet on center. They are constructed of double top and bottom chords with web members

Figure 2.--Detail of door and window header.

M 129 528

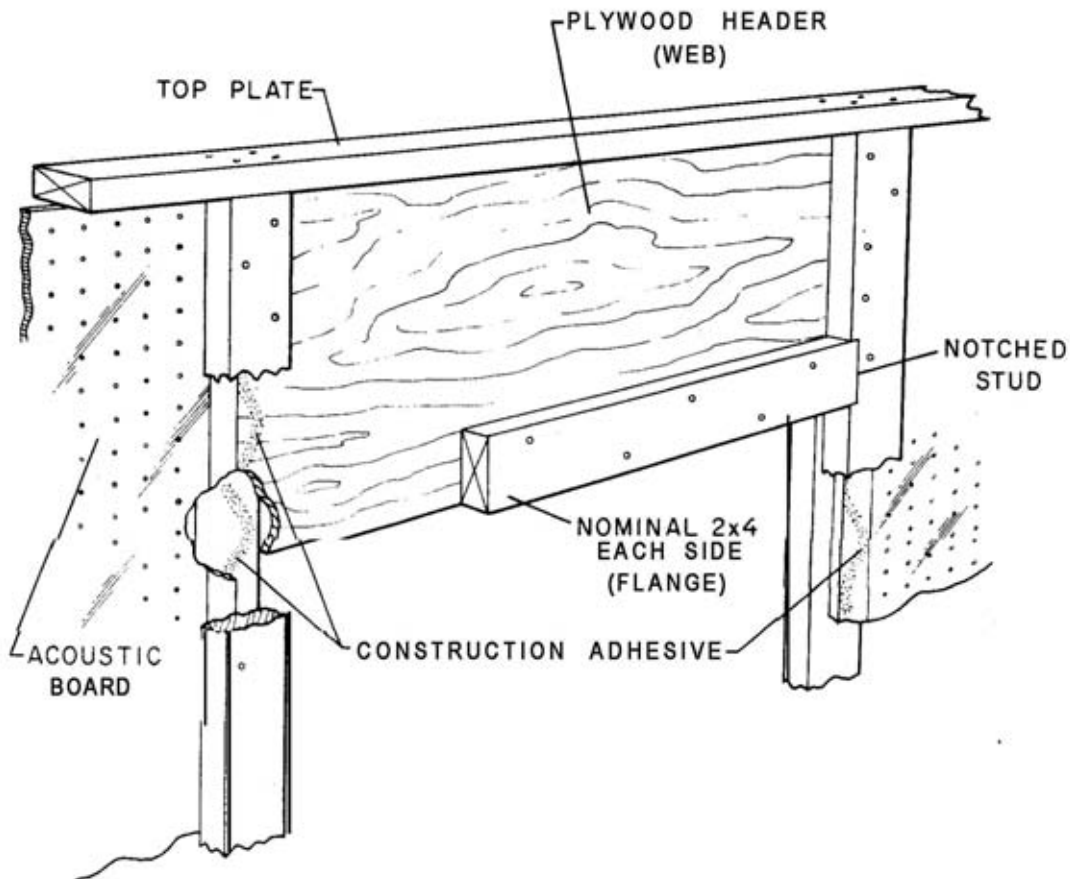

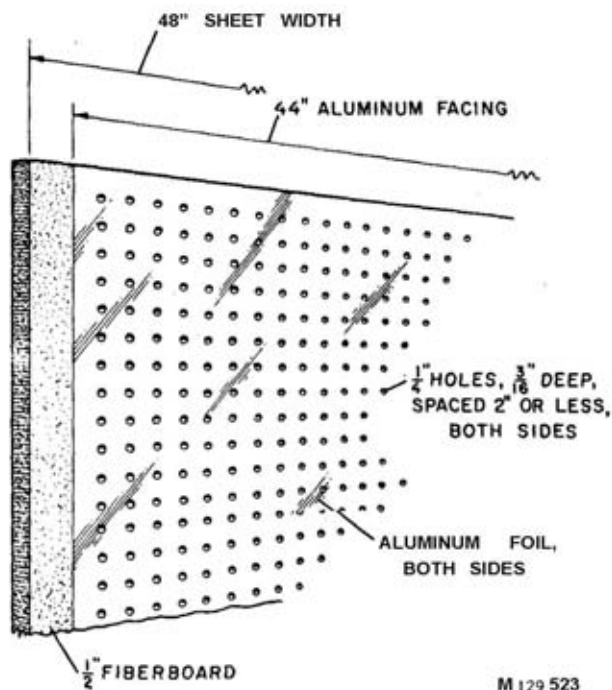

Figure 3.--Detail of acoustic-insulating fiberboard (Insul-2).

and plywood gussets between. Conventional glued-plywood gusset trusses are usually made of single members with gussets on each side of the joints and are commonly designed for 2-foot spacing. Thus, although the gussets are larger and thicker, the double truss members of the Nu-frame system have only one-fourth the number of gussets of conventional wood trusses.

Two types of trusses were constructed, the conventional "W" or Fink truss with a 4:12 slope using 2- by 4-inch chord members and the "king-post" truss with a 2:12 slope using 2- by 6-inch chord members, figure 4, A and D.

The W-trusses were constructed in two manners. In one, the web or diagonal members were nominal 2 by 4 inches in size and were fastened to upper and lower chord members with plywood gussets which were nail-glued to the diagonal and between the double-chord members, figure 4B. Other connections were made by means of nail-glued plywood gussets between truss members. The other type of W-truss was arranged so that both the 5/8-inch plywood connecting gussets and diagonal members were nail-glued between the double upper and lower chords, figure 4C.

The king-post trusses were made in the same general manner as the W-trusses. Upper and lower chords were doubled, connecting plywood gussets were nail-glued between the members,

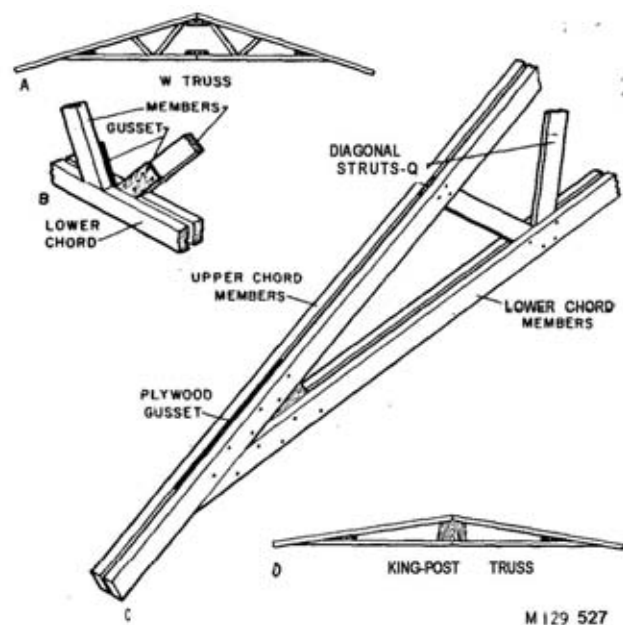

Figure 4.--Construction details of trusses

and the post or vertical center member served also as a splicing member between lower chords and as a ridge connection.

Assembly of the double truss was somewhat difficult in low-pitch trusses of the king-post type. This occurred when there was a twist in the 2- by 6-inch members. Under these conditions clamps or other pressure systems were required when trusses were assembled. The W-truss, commonly used for slopes of 4:12 and greater, required 2 by 4 members and thus twist was normally not a problem. However, both the king-post and the W-truss, figure 4, were constructed and tested.

Precut truss members were positioned in a prepared jig. The 5/8-inch-thick plywood gussets and contact areas of the frame members were then spread with glue and upper and lower frame members were fastened in place. Twelve penny annular groove nails were used and were quite effective, if members were straight, in providing pressure until glue had set. However, the following system using screws would probably be more positive and require less time:

(a) Top frame members could be predrilled at gusset and diagonal locations before assembly.
 (b) After glue spreading, 3- or 3-1/2-inch-long wood screws could be turned in place with a clutched power-driven screwdriver. This method would probably eliminate the need for clamps. In production line assembly, however, power clamping would assure an even better product.

Interior Covering Material

Because both wall and roof framing members were spaced 4 feet on center, the material used to finish interior walls and ceilings must also be designed for this spacing. This was accomplished by combining low-grade softwood boards with a gypsum sheet product to form "Perm-board" panels. Foil-backed 1/4-inch gypsum board in 4-by-8-foot sheets was used as a base material and 5/8-by-5-1/2-inch boards were spaced about 6 inches apart and glued lengthwise to the foil side of the sheet, figure 5. Edge boards were

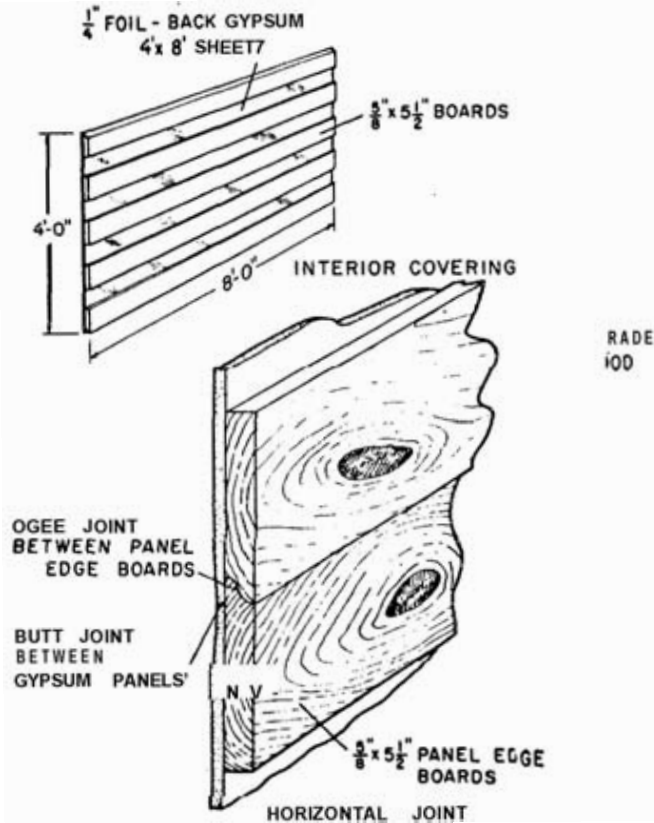

Figure 5.--Interior drywall covering for walls and ceilings (Perm-board).

molded to provide a lock joint and horizontal stability. This was required because the 4-by-8-foot sheets are applied lengthwise across two 4-foot spaces with staggered vertical joints. Application to frame members was accomplished with a bead of construction adhesive on each stud or bottom truss member. Two eightpenny annular groove nails were used at each board. Joints are taped and spackled as in conventional gypsum drywall construction.

It is important that a moisture content of about

9 to 10 percent for the wood boards be reached before gluing to the gypsum board. This will minimize the tendency of the boards to twist or cup which would occur if a board of high moisture content were used.

Roof Covering

The roof sheathing and roofing were combined into one laminated plank, "Plastic-plank," designed to span the 4 feet between each rooftruss. The Plastic-plank was manufactured by laminating a nominal 1 inch or thicker board between two pieces of plywood, resawing to a bevel shape, and machining to form a locking pattern, figure 6. Two planks were formed from one board. The exposed face and edge surfaces of the plank were covered with an asbestos-backed polyvinyl fluoride film providing a prefinished, long-lived surface. Lengths of the planks were 8, 12, or 16 feet to correspond with the 4-foot spacing of the trusses.

Fastening the prefinished roof plank to the trusses was accomplished with adhesive and nails. A bead of construction adhesive on the truss member and one eightpenny annular groove nail per board for each intersection with a framing member fastened the plank in place, figure 6. The lap of the following plank covered

Figure 6.--Details of prefinished roof plank (Plastic-plank).

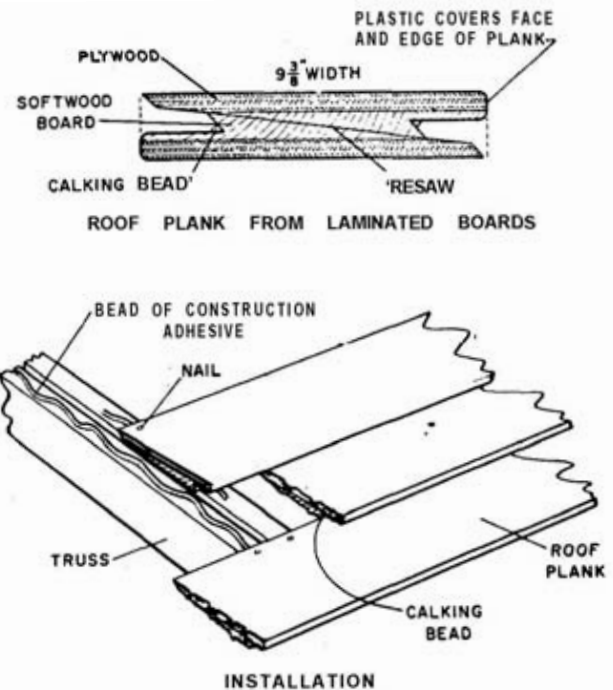

the nails. To provide a positive seal laterally between boards, a bead of rubber-based calking compound was used. Butt joints were made over a roof member, sealed, and taped with a poly-vinyl fluoride tape.

Siding-Sheathing Coverage

The combination siding-sheathing material, "Twin-board," which was the original material developed for the Nu-frame system of construction, was made of vertical grain redwood in combination with low-grade softwood boards. The Plastic-plank previously described can also be used as a combination siding material.

Redwood boards were resawn to form bevel drop siding, and two such pieces were glued to a backing of low-grade pine boards to make up the Twin-board units, figure 7. The pine backing consisted of edge-glued random-width boards.

The finished siding-sheathing material provided a locking double-lapped horizontal joint with interlocking end joints. All joints were made over the studs. Lengths were 8, 12, and 16 feet to conform to the 4-foot stud spacing. The plank width was made so that it produced a 12-inch face width when installed. The resawn outer surface of the siding was prestained.

Ribbons of construction adhesive and blind nailing at each stud were used to fasten the siding material in place. After the adhesive was applied, the groove of the siding was placed in the tongue of the lower piece and nailed to the stud, figure 7.

In combinations such as the Twin-board and the Plastic-plank roof boards, it is important that the moisture content of the two materials be about equal at the time of gluing. An average moisture content of about 9 to 10 percent should be satisfactory for most parts of the country except the dry Southwest.

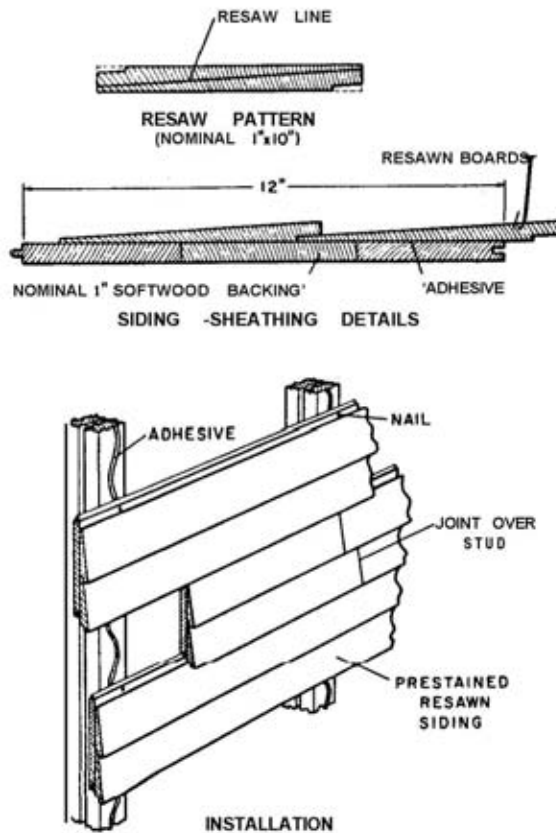

Figure 7. --Details of siding-sheathing component (Twin-board).

M 129 526

RESULTS OF EVALUATIONS

Strength and rigidity tests were made on wall panels and roof trusses as well as on several other of the components used in the newly developed framing system. An exposure test is also being conducted on a roof panel made up of the laminated roof planking. The following sections outline results of the stiffness and strength tests and the roof exposure study.

Wall Framing

Racking tests were made on 8- by 8-foot wall panels with several variations in construction. Panels with one, two, or three diagonal braces in three sizes were tested as well as several panels containing 1/2-inch fiberboard between the studs. Fiberboard was used in 4-foot-wide full-height sheets and applied with adhesive and nails as previously described,

The testing procedures outlined in ASTM Designation E 72, "Standard Methods of Conducting Structural Tests of Segments of Wall, Floor, and Roof Construction," were generally followed in testing the panels to determine their resistance to racking.

The wall panels were subjected to a racking load applied horizontally to an upper corner of the panel. The racking test equipment consisted of a rigid steel frame with the load applied by a hydraulic jack, figure 8.

Results of the racking tests made with various sizes and numbers of diagonal braces and combined with fiberboard are shown in table 1. All tests were made with the braces in compression.

For the purpose of comparison, the performance of a horizontally sheathed wall panel with 1- by 8-inch southern pine sheathing and with studs spaced 16 inches on center was used as a control, design A of table 1. This might be considered a minimum wall but most building regulations require some type of bracing in addition. As noted in table 1, all panels were more rigid than the control panel except the type with two half braces, design E. The most rigid panels were those with three braces of 1- by 10-inch size, design H, and the fiberboard panels, design I. Both types, with 48-inch stud spacing, were more than two times as rigid as the control panel,

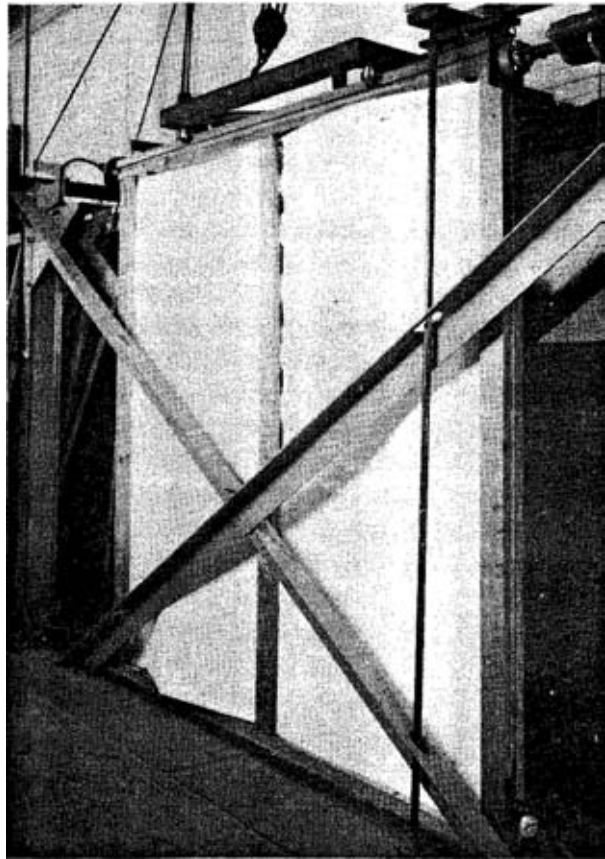

Figure 8.--Wall panels of the Nu-frame system were subjected to racking tests in a rigid steel frame. Duckling of fiberboard and shear at the center studs are apparent.







M 128 102

design A, with 16-inch stud spacing.

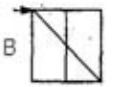
Most diagonally braced panels, designs B to F, did not equal the horizontally sheathed control panel in strength. However, panels with one full diagonal and two half diagonals in 1- by 8- and 1- by 10-inch size, designs G and H, sustained higher maximum loads before failure. The fiberboard panel was about equal in strength to the best diagonally braced panels and about 40 percent greater in strength than the control panel. Figure 8 shows the fiberboard panel, design I, after reaching maximum load.

It is likely that the Nu-frame wall with 4-foot spacing of double studs and the use of properly applied 1/2-inch insulation board (Insul-2) between studs would provide more than sufficient rigidity and strength when the siding-sheathing material is in place. Furthermore, the addition

Table 1.--Results of racking tests of Nu-frame wall panels

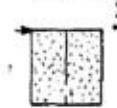
Design	Diagonal braces		Load at 0.5-inch deflection	Relative rigidity	Maximum load	Relative strength
	No.	Size				
		In.	Lb.		Lb.	
 A.	None	Control panel	690	1.0	1,310	1.0
 B.	1	1 x 6	850	1.2	1,175	.7
 C.	1	1 x 8	860	1.2	880	.7
 D.	1	1 x 10	1,060	1.5	1,127	.9
 E.	2	1 x 10	375	.6	1,100	.6
 F.	3	1 x 6	990	1.4	1,150	.9
 G.	3	1 x 8	1,240	1.8	1,665	1.3
 H.	3	1 x 10	1,450	2.1	2,013	1.5
 I.	None	Fiberboard between studs	1,530	2.2	1,845	1.4

¹Control panel--2 x 4 studs 16 inches on center, 1 x 8 horizontal sheathing, two eightpenny nails per stud crossing.
²Insul--2 1/2-inch fiberboard.

of large sheets of the interior Perm-board would provide even greater rigidity and strength.

Roof Trusses

Roof trusses were designed for a roof load of 30 pounds per square foot over a 26-foot span on 4-foot spacing. Trusses were evaluated in accordance with the procedures outlined in ASTM

Designation E 73, "Methods of Testing Truss Assemblies." Loads were applied by means of hydraulic jacks and deflections were measured at load increments of approximately 300 pounds. Tests were initially carried to design load, about 3,100 pounds. The load was then released and again applied until failure occurred.

Table 2 lists the results of the bending tests made on the W-trusses. When initial failure consisted only of shear of the glue-line of the

Table 2.--Results of bending tests of W-trusses¹

Truss No.	Size of diagonals (web member)		Lower chord splice gusset	Stiffness at design load ²	Maximum load	
	Compression	Tension			Pounds	Times design load
	In.	In.		In. per In.		
W-2/4-1	2 x 4	2 x 4	Small	1/1600	6,320	2.1
W-2/4-2	2 x 4	2 x 4	Medium	1/1460	7,400	2.5
W-P-1	5/8 x 5-1/2	5/8 x 4-1/2	Small	1/1500	6,270	2.1
WP2	5/8 x 5-1/2	5/8 x 4-1/2	Medium	1/1500	5,500	1.8
W-B-	5/8 x 5-1/2	5/8 x 5-1/2	Small	1/1200	1,670	2.5
N-B-2	5/8 x 5-1/2	5/8 x 5-1/2	Medium	1/1850	8,820	2.9

¹Trusses constructed for 26-foot span, 4/12 slope, with double,

²2- by 4-inch upper and lower chords.

³Deflection-span ratio at design load of 3,100 pounds.

lower chord splice plate, the truss was repaired with additional reinforcing and rerun. As noted, the stiffness of the trusses under a variety of conditions was more than adequate. Deflection-span ratios varied from an average of 1/1200 to 1/1850. Some individual trusses were even stiffer. Wood or plywood web members, with a reinforced splice gusset to resist bending of the lower chord as well as shear stresses, and double 2- by 4-inch upper and lower chord members (W-B-2) resulted in a truss capable of resisting nearly three times the design load of 30 pounds per square foot.

Table 3 lists the results of the bending tests made on the king-post trusses. As noted, the stiffness of the trusses was more than adequate, averaging 1/1100. The 5/8-inch plywood post member of this type of truss also served as a splice and connecting gusset for the upper and lower chords. Reinforcing this member with

Table 3.--Results of bending tests of king-post trusses¹

Truss No.	Connections			Stiffness at design load ²	Maximum load	
	Heel gusset	Center post	Alterations		Pounds	Times design load
	Sq. in.	Sq. in.		In. per In.		
K-W ³	90	450	None	1/1070	6,020	2.0
K-W ⁴	175	900	None	1/1180	6,025	2.0
K-W-R ⁵	175	900	King-post reinforced: with 650 square inches of 1/2-inch plywood	1/1100	7,475	2.5

¹Trusses constructed for 26-foot span, 2/12 slope, with double,

²2- by 4-inch upper and lower chords.

³Deflection-span ratio at design load of 3,100 pounds.

⁴Narrow--15-inch-wide, 5/8-inch-thick plywood post.

⁵Wide--30-inch-wide, 5/8-inch-thick plywood post.

⁶Wide--30-inch-wide, 5/8-inch-thick plywood post reinforced with 1/2-inch plywood each side.

1/2-inch plywood on each side, truss K-W-R, increased the average maximum load by about 25 percent.

Exposure of Roof Panel

In order to determine the ability of the Plastic-plank roof board system to resist water entry, a 6- by 8-foot roof section was mounted on a simulated truss framework designed for variable roof slopes, figure 9. Exposure since erection in April 1964 has been at a 6/12 slope and toward the southwest for maximum exposure to rains. Assembly of the roof planking conformed to the details previously outlined except that one 8-foot-long horizontal joint was protected by brush coating the edges of the boards with a water-repellent preservative rather than using a synthetic rubber calking seal. The back side of the roof panel was examined after each significant rainfall. After a 1-year exposure, each horizontal joint treated with the synthetic rubber calking bead was free of visible moisture. The joint treated with water-repellent preservative had a very slight trace of moisture but only after a heavy rainfall when wind velocities were more than 40 miles per hour.

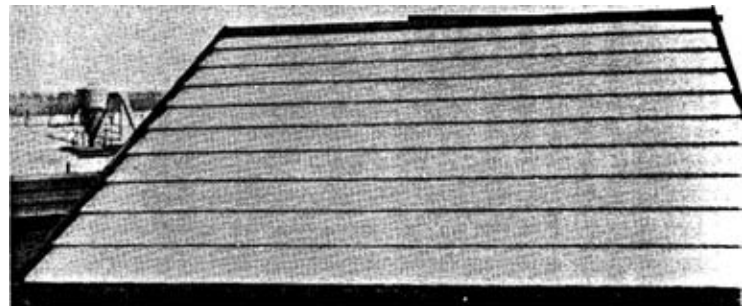

Figure 9.--The roof planking overlaid with plastic film shows no deterioration after 1 year of exposure.

M 128 107

Strength Tests of Perm-board

Concentrated load and impact drop tests were made on (a) 4- by 8-foot sections of the wood reinforced gypsum (Perm-board), and on (b) 3/8-inch gypsum board which was used as a control. Support members were spaced 4 feet on center for the Perm-board and 16 inches on center for the 3/8-inch gypsum.

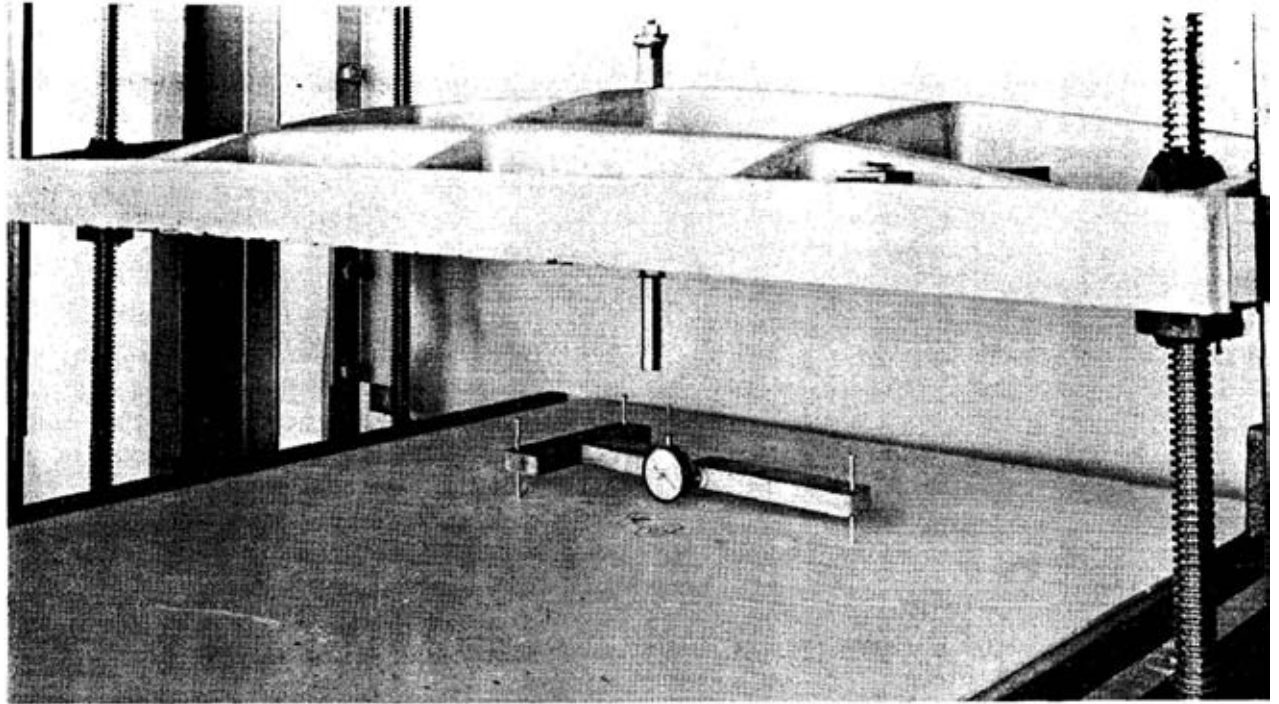

Figure 10.--Concentrated load test with 1-inch-diameter cylinder

Two types of tests were conducted (a) a concentrated load consisting of a 1-inch-diameter round steel bar located at midpoint between supports, figure 10, and (b) a drop test with a 60-pound bag, figure 11.

Concentrated load test.--Examination of the performance of the Perm-board and the 3/8-inch gypsum board control panel were made at a

Figure 11.--Drop test with 60-pound bag. Gypsum board was fractured by the bag in this control panel.

M 128 103

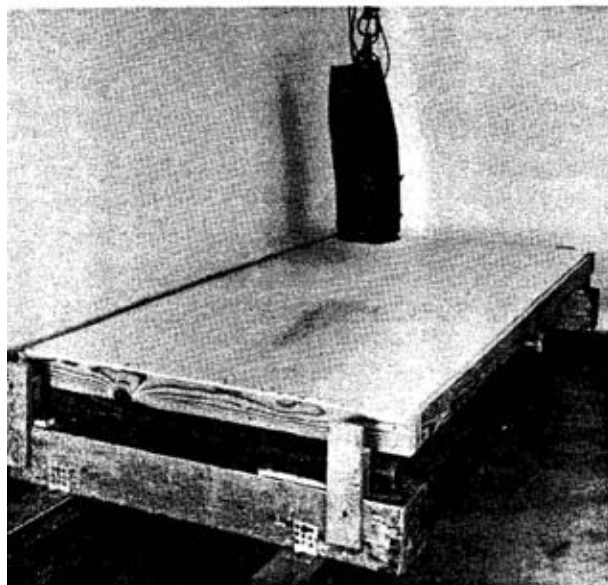

deflection-span ratio of 1/240 for each panel. The load on the 3/8-inch gypsum panel at this ratio with a deflection of 0.067 inch (16-in. span) was about 40 pounds. The load on the Perm-board panel at this ratio with a deflection of 0.20 inch (48-in. span) was 110 pounds. The load at a deflection of 0.1 inch was about 60 pounds for each panel. At a 0.25-inch deflection, loads were 108 pounds for the control panel and 150 pounds for the Perm-board panel,

Maximum load was 125 pounds for the control panel and 388 pounds for the Perm-board panel. Deflections at maximum load were 0.31 and 0.66 inch, respectively. Final failure consisted of punching through the gypsum.

Drop test.--The 60-pound bag was dropped on the face of the panels from an initial height of 6 inches, figure 11. The panels were supported at each end and the bag dropped on the center of the face of the panel.

The gypsum control panel failed at the 6-inch drop with a maximum deflection of 1.3 inches. The Perm-board panel sustained the 6-inch drop but failed at the 12-inch drop with a maximum deflection of 2.3 inches. Failure consisted of fracture of the gypsum board.

Based on the results of the concentrated load and the drop tests, the Perm-board with 4-foot spacing of studs performed better than the standard 3/8-inch gypsum board control panel with 16-inch stud spacing.

PROTOTYPE STRUCTURE

A model building incorporating the principles of the Nu-frame construction system is shown in figure 12. Simplicity of construction is the most evident feature. The number of pieces to handle during assembly and the need to cut and fit 2-inch dimension material has been considerably reduced. The exterior roof and wall components

are composed of interlocking units that require only one nail for each 3- to 4-square-foot area; the fastening load is shared by construction adhesive. Relatively low-cost materials are used throughout with no compromise in structural quality.

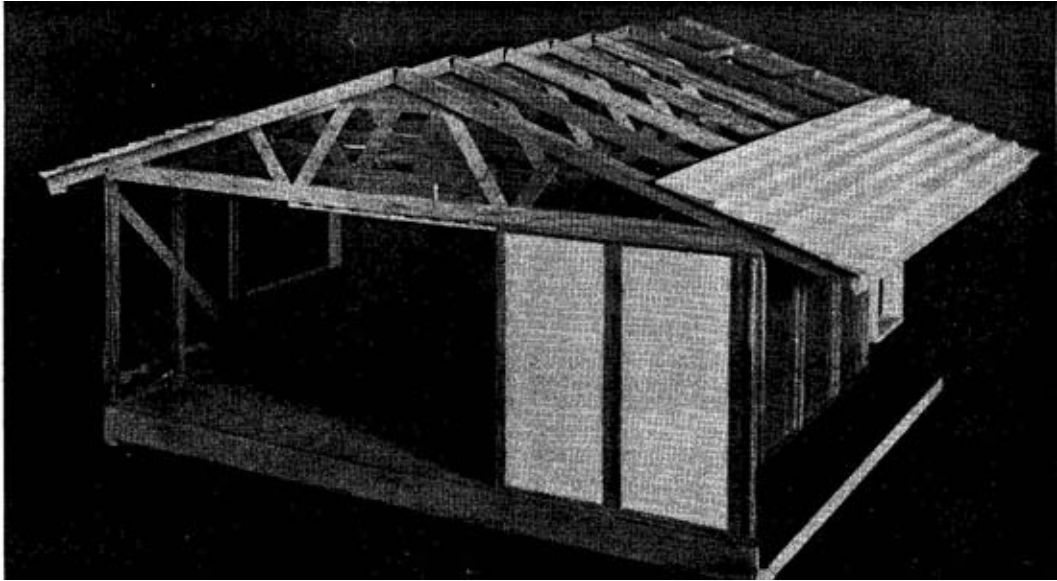

M 129 403

Figure 12.--Views of the Nu-frame model showing: A, the W-truss roof framing overlaid with Plastic-plank roofing; and B, the braced walls covered on the outside with Twin-board and on the inside with Perm-board.

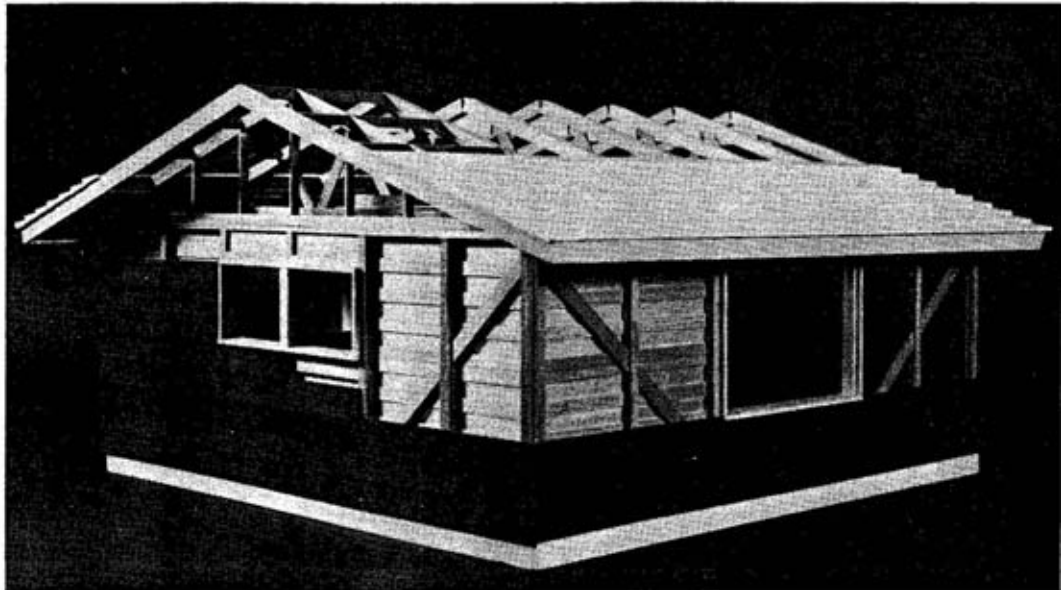

CONCLUSIONS AND RECOMMENDATIONS

The Nu-frame construction system with factory assembled, prefinished components lends itself well to rapid assembly and requires a minimum of on-site labor. The system combines economical wood products in panel-type units which are fastened to wall and roof framing with both construction adhesive and nails. Strength and exposure studies have shown that the components of the system compare favorably with conventional construction.

Based on the laboratory evaluation of the Nu-frame construction system, it appears that a full-scale experimental building is justified. Detailed recommendations for such a unit have been prepared. A 28- by 40-foot building is proposed which will incorporate not only the various components of the Nu-frame system but also moisture, temperature, ventilation, and acoustical studies.

