



2014

Considering the Use of Epoxies in the Repair of Historic Structural Timber

Ryan Cleary
University of Pennsylvania

Follow this and additional works at: http://repository.upenn.edu/hp_theses

 Part of the [Historic Preservation and Conservation Commons](#)

Cleary, Ryan, "Considering the Use of Epoxies in the Repair of Historic Structural Timber" (2014). *Theses (Historic Preservation)*. 568.
http://repository.upenn.edu/hp_theses/568

Suggested Citation:

Cleary, Ryan (2014). *Considering the Use of Epoxies in the Repair of Historic Structural Timber*. (Masters Thesis). University of Pennsylvania, Philadelphia, PA.

This paper is posted at ScholarlyCommons. http://repository.upenn.edu/hp_theses/568
For more information, please contact libraryrepository@pobox.upenn.edu.

Considering the Use of Epoxies in the Repair of Historic Structural Timber

Abstract

Wood is one of the earliest and most common building materials on the planet. However wood also quickly decays under normal service conditions, and thus the repair of historic structural elements pose a difficult challenge to preservation professionals who aim to also preserve the authenticity of the element. Since the 1970s, numerous studies have looked at the use of epoxy with respect to historic timber repair. Epoxy, for the purposes of structural repair, serves as a substitution type repair for deteriorated wood. In this study focuses on the compatibility of historic structural timber members and epoxy repairs by the means of a reviewing and analyzing the state of the art of epoxy and wood durability and structural functional performance over the past couple of decades as a means to reconsider epoxy use in the preservation of historic structural timber members. Epoxy repairs to historic timber members are categorized by their application; consolidation, structural adhesive and gap-filling structural adhesive. The intent of this approach is designed to consider how the increase in the unit volume of epoxy to wood ratio affects the properties that affect the structural performance and compatibility of such repairs.

Keywords

epoxy, wood, timber, repair, compatibility

Disciplines

Historic Preservation and Conservation

Comments

Suggested Citation:

Cleary, Ryan (2014). *Considering the Use of Epoxies in the Repair of Historic Structural Timber*. (Masters Thesis). University of Pennsylvania, Philadelphia, PA.

CONSIDERING THE USE OF EPOXIES
IN THE REPAIR OF HISTORIC STRUCTURAL TIMBER

Ryan Cleary

A THESIS

In

Historic Preservation

Presented to the Faculties of the University of Pennsylvania
In Partial Fulfillment of the Requirements of the Degree of

MASTER OF SCIENCE IN HISTORIC PRESERVATION

2014

Advisor
Michael C. Henry, PE, AIA
Adjunct Professor of Architecture

Program Chair
Randall F. Mason, Ph.D.
Associate Professor

To My Family, Friends & Mentors.

Acknowledgements

First and foremost, I would like to thank my advisor, Michael Henry, for all his time and patience for working with me on the development and writing of this of this thesis. Without his input, guidance and mentoring this thesis would not have been possible.

Thanks to Donald Friedman and Marie Ennis for their support and thoughts on this topic. I would also like to thank Rick Ortega and Ronald Anthony for discussing this topic and helping spark the interest to pursue it as a thesis.

Thanks to the rest of the faculty and staff of the Historic Preservation department for teaching me the skills to see this to completion.

And finally, a huge thank you to my family and friends for supporting me on my journey back to school and providing the inspiration to see this to completion.

Table of Contents

Table of Contents.....	iv
List of Figures.....	vii
List of Tables.....	vii
Chapter 1 - Introduction	1
Historic Wood	1
Historic Timber Repair Methods.....	3
Epoxy Resin as an Adhesive.....	4
Epoxy Resin as a Consolidant.....	5
Epoxy Resin as a Structural Gap-Filling Adhesive	7
The Durability of Epoxy Repairs.....	8
Summary and Thesis	9
Chapter 2 –Historic Timber Restoration and Epoxy Repairs	11
Options for Structural Repair of Historic Timber	12
Conservation Guidance and Timber Repairs	13
The Development and Types of Epoxy Repairs for Historic Structural Timber	15
Epoxy as a Structural Adhesive	15
Epoxy as a Consolidant	18
Epoxy as a Structural Gap-Filling Adhesive.....	19
Chapter 3 –Material Composition and Properties: Wood	23
Wood Composition	23
Wood Properties.....	25
Mechanical Properties.....	25
Physical Properties	31
Surface Properties.....	33
Property Values of Historic Woods Commonly Used in Historic Structural Framing in the United States	35
Physical and Working Properties	38
Mechanical Properties.	40
Properties of Epoxy Products for Wood Repair.....	41
Chapter 5 –Structural Compatibility of Wood and Epoxy	45

Compatibility with Respect to Epoxy Consolidants.....	46
Micro Morphology of Southern Pine, White Oak & American Chestnut	47
Factors Affecting Epoxy When Used as a Structural Adhesive	50
Structural Adhesive Bonds with Respect to Historic Timber	55
Factors affecting Epoxy When Used as a Structural Gap-Filling Adhesive	56
Summary of Factors Affecting Epoxy –Wood Structural Compatibility	58
Chapter 6 –Conclusions & Recommendations	60
Conclusions.....	61
Assessment of Structural Compatibility with Regards to Epoxy Use as a Consolidant	61
Assessment of Compatibility with Regards to Epoxy Use as a Structural Adhesive	63
Assessment of Compatibility with Regards to Epoxy Use Structural Gap-Filling Adhesive... ..	65
Summary of Conclusions regarding Compatibility with Respect to Epoxy Application	67
Appendix A: Abatron LiquidWood & WoodEpoxy Technical Specifications	73
Appendix B: Araldite 1253 Technical Specifications	78
Appendix C: ART Flex-TEC Technical Specifications.....	83
Appendix D: Conserve 100 Technical Specifications	86
Appendix E: PC Rot Terminator Technical Specifications	89
Appendix F: Rotafix Resiwood TG6 Technical Specifications	95
Appendix G: Sikadur 32 Hi Mod Technical Specifications	97
Appendix H: Smith System CPES Product Literature	100
Appendix I: Triton Trimol 36 Technical Specifications	106
Appendix J: West System 105/205 Technical Specifications.....	110
Index	112

List of Figures

Figure 1: Plywood Reinforcement of a Deteriorated Beam	19
Figure 2: Resin-Bonded Timber Repair.....	20
Figure 3: Wood Epoxy Reinforcement System Repair with Steel Reinforcement.....	23
Figure 4: BETA System Epoxy Repair.....	24
Figure 5: Physical structure and composition of a wood cell.....	26
Figure 6: Chemical composition of a cell wall.....	27
Figure 7: The three principal and orthogonal axes of wood.....	28
Figure 8: (a) Tensile load parallel to the grain and perpendicular to the grain.....	29
Figure 9: (a) Compressive load parallel to the grain and perpendicular to the grain.....	30
Figure 10: Shear load parallel to the grain.....	31
Figure 11: Flexural load.....	32
Figure 12: Adhesive Bondlines in (A) a sound wood surface and (B) a poor, crushed, wood surface.....	36
Figure 13: Epoxide Functional Group.....	39
Figure 14: Working Times of Epoxy Wood Repair Products.....	44
Figure 15: Cure Time of Epoxy Wood Repair Products.....	45
Figure 16: Tensile Strengths of Epoxy Wood Repair Products.....	45
Figure 17: Compressive Strengths of Epoxy Wood Repair Products.....	46
Figure 18: Flexural Strengths of Epoxy Wood Repair Products.....	46
Figure 19: Cross section views of American Chesnut, Southern Yellow Pine and White Oak...50	
Figure 20: Longitudinal/radial plane in pine sapwood showing the effect of flow through distorted window pit membranes.....	51
Figure 21: Fractional retention of epoxy in ray tracheids in both pine and spruce sapwood and heartwood.....	52
Figure 22: Idealized layers of a bonded wood joint in schematic form.....	53
Figure 23: General effect of conditions on adhesive penetration.....	55
Figure 24: Effect of grain orientation on failure shear stress	57
Figure 25: Typical beam-end repair with reinforcing bars	58
Figure 26: Structural compatibility with regards to consolidation and wood species.....	64

List of Tables

Table 1: Comparison of Repair Approach and Conservation Criteria	15
Table 2: Properties of Wood Species Found in Historic Structures in the United States (Source: Wood Handbook: Wood as an Engineering Material, 2010)	35
Table 3: Epoxy Products for Wood Repair	41
Table 4: List of variables that affect the bond performance of wood assemblies bonded with adhesives. <i>Source: Handbook of Wood Chemistry and Wood Composites</i>	46
Table 5: Summary of Structural Compatibility and Durability Assessment with regards to Epoxy Based Repairs for Wood and Service Condition	67
Table 6: Summary of Historic Wood Species Bonding Compatibility.	69

Chapter 1 - Introduction

The objective of this thesis is to assess the compatibility of historic structural timber members and epoxy repairs by the means of a reviewing and analyzing the state of the art of epoxy and wood durability and structural functional performance over the past couple of decades as a means to reconsider epoxy use in the preservation of historic structural timber members. Epoxy repairs to historic timber members are categorized by their application; consolidation, structural adhesive and gap-filling structural adhesive. The intent of this approach is designed to consider how the increase in the unit volume of epoxy to wood ratio affects the properties that affect the structural performance and compatibility of such repairs. The first chapter provides a literature review of the state of the art. Next, a review of the history of epoxy repairs to structural timber is provided. The following two chapters examine the properties of historic structural timber and epoxy, respectively. Finally, the last two chapters present both a discussion of the how these material properties perform with respect to both epoxy application category and environmental conditions in order to provide a conclusion on their compatibility.

Historic Wood

Wood is one of the earliest and most common building materials on the planet. It is particularly interesting because, unlike many building materials, it is orthotropic, meaning that its properties vary based on the direction of the considered axis. However, at the chemical level all wood is composed of wood cells which are made of lignin, which binds the fibers together,

and cellulose, a linear polymer that comprises the cell walls.¹ In addition to lignin and cellulose other chemicals such as hemi-cellulose, extractives and ash vary with species and add to its chemical, mechanical and physical properties. However, the major determinant of chemical composition is a tree's subdivision, which is classified as either a hardwood or softwood.² Hardwoods are generally higher in cellulose than softwoods. However, softwoods have a greater amount of lignin. A wood species' chemical composition is the primary contributing factor to the resistance to decay. This is of importance because decay negatively affects mechanical properties, resulting in loss of functional performance.³ Although there are hundreds of wood species in the northeastern United States, Hoadley found that the majority of historic structures in this region were built of either oak, chestnut or hard pine.⁴

For historic structural timber, the chemical composition, state of decay, and functional performance are not the only considerations that define historical value. Graham identified eight characteristics associated with historic timber and categorized them as either an emotional value or a matter of historical record. Under emotional values, he identified "delight of an authentic structure retaining a maximum of historic fabric", "patina and aesthetics", "color/finish", and "historic graffiti." He identified "carpenters' marks", "timber conversion methods", "carpentry methods", and "dating by dendrochronology" as items that are a matter of historical record.⁵ Although there appears to be some overlap in his categories, he has done a good job of distinguishing between features that add age value versus those that reveal the

¹ Keith F. Faherty, Thomas G. Williamson, and Harry E. Humphreys Book Fund., *Wood engineering and construction handbook*, 3rd ed., 1 vols. (New York: McGraw-Hill, 1997).

² Thomas Nilsson and Roger Rowell, "Historical wood – structure and properties," *Journal of Cultural Heritage* 13, no. 3, Supplement (2012).

³ Ibid.

⁴ R. Bruce Hoadley, *Identifying wood : accurate results with simple tools* (Newtown, CT: Taunton Press, 1990).

⁵ Tony Graham, "Resin Bonded Timber Repair and the Preservation of Historic Timber Surfaces" (University of Bath, 2004).

structure's building technology. Graham goes on to argue that "the timber surface articulates these values." Thus, he is ultimately arguing that the conservation of that surface wood is more valuable than wood beneath the surface. Regardless of this argument, Graham correctly identifies that historic wood, as opposed to new wood, not only tells the structure's story but adds to the age value of the structure. Graham's thesis notably omits structure as contributing to the historic value; however, his thesis attempts to find a solution to reestablish functional performance while maintaining the aforesaid historic values. Although, he doesn't identify the epoxy bonded pieces of salvaged veneer as contributing to the structure, they would, in fact, add additional section to the replacement timber and thus contribute to the structural performance.

Historic Timber Repair Methods

Wheeler and Hutchinson (1998) summarized available timber repair methods into the following three categories: (1) Traditional/Vernacular Repairs, (2) Mechanical Methods and (3) Resin Repair.⁶ In a traditional repair, carpentry of the age is replicated with new wood to repair a timber structural member. In mechanical repair methods, another structural element is typically attached or bolted to the decayed timber. And in resin repair, epoxies are used to augment the damaged or deteriorated timber in order to reinstate its mechanical properties. Epoxies were initially patented in the 1930s.⁷ However, it was not until the 1960s and 1970s did the technology of epoxy resins was applied to timber repairs. In 1978, Morgan Phillips and Dr. Judith Selwyn, both from the Society for the Preservation of New England Antiquities, completed a report on the use of epoxy for the repair of wood on historic structures. The

⁶ A. S. Wheeler and A. R. Hutchinson, "Resin repairs to timber structures," *International Journal of Adhesion and Adhesives* 18, no. 1 (1998).

⁷ H.Q; Marks Pham, M.J., "Epoxy Resins," in *Ullmann's Encyclopedia of Industrial Chemistry* (Freeport, TX: Dow Chemical, 2012).

objective of their study was to research and carry out a preliminary testing program on epoxies. Their research was primarily focused on epoxy formulations for consolidation and patching timber. However, they identified the following as possible areas where epoxies might be used in the field of architectural conservation: plaster consolidant, flexible adhesive, clamp-free adhesive, gap-filling adhesive, elastomeric sealant, glazing compounds or as a soil consolidant. Although these 'possible' uses of epoxies were never tested, they attest that Phillips and Selwyn valued epoxy's consolidation and adhesive properties.

Epoxy repairs to timber can be categorized by the ratio of epoxy by volume compared to the wood volume restored. In order of increasing epoxy to wood volumetric ratio, these epoxy repair categories are: as a consolidant, as an adhesive, and as a gap-filling (patching) adhesive.⁸

Epoxy Resin as an Adhesive

In his paper on the application of epoxy resins for historic structures, Paul Stumes (1971) claimed that "epoxy by itself is a fairly good adhesive with 100 to 150 psi shear strength and perfect weather resistance."⁹ However, by the time that Stumes' made such claims, the Gougeon Brothers, Inc., founders of the West System®, had been already using epoxies as a structural adhesive in the wooden boat industry for over a decade. Wheeler and Hutchinson (1998) found that epoxy resins were capable of bonding wood with moisture contents up to 22% without any negative effect to bond strength.¹⁰ Of greater interest, they stated their tests could not prove that epoxy bonds would be as durable as other timber repair methods or were appropriate for fully exposure to environmental conditions. Broughton (2001) reported a similar

⁸ Morgan W. Phillips and Judith E. Selwyn, *Epoxies for Wood Repairs in Historic Buildings* (Washington: Office of Archeology and Historic Preservation, Heritage Conservation and Recreation Service, U.S. Dept. of the Interior, Technical Preservation Services Division : for sale by the Supt. of Docs., U.S. Govt. Print. Off., 1978).

⁹ Paul Stumes, "The Application of Epoxy Resins for the Restoration of Historic Structures," *Bulletin of the Association for Preservation Technology* 3, no. 1 (1971).

¹⁰ Wheeler and Hutchinson, "Resin repairs to timber structures."

conclusion that “high, strength joints can be made with epoxy resins adhesives” and “that the effect of high timber moisture contents, both prior and following bonding, has minimal effect on the integrity of epoxy-bonded joints.”¹¹ Lavisci, Berti, Pizzo, Triboulot and Zanuttini (2001) tested the shear strength of timber joints with 10 different adhesives and varying joint thicknesses prior to, and after, accelerated weathering. By comparing these values to solid wood shear strengths they were able to comment on the ratio of dry (un-weathered) to wet (weathered) strength. They found only two adhesives that exhibited both a wet strength and dry strength greater than that of a comparable solid wood specimen, thus contradicting the claim made by Broughton and Hutchinson and giving proof that weathering may have a significant negative effect on structural performance of an epoxy repair.¹² Lavisci, Berti, Pizzo, Triboulot and Zanuttini stopped sort of making any recommendation for requirements for structural wood adhesives.

Epoxy Resin as a Consolidant

When epoxy was used in a manner to consolidate historic timber, Phillips and Selwyn (1978) determined that an epoxy should exhibit low shrinkage, a reliable curing mechanism, durability, reversibility, adjustable strength, low toxicity, low viscosity and good paint retention.¹³ Although they acknowledged that thermosetting compounds, such as epoxies, are not reversible to any practical extent, they conceded that the ‘greater strength and increased resistance to some aspects of weathering’ were advantages that allowed for its use in historic timber. They stated that the high viscosity of epoxies was the primary drawback when used to consolidate timber. Phillips and Selwyn did not quantify their research results regarding the use of epoxies

¹¹ J. Broughton, Hutchinson, A., "Adhesive systems for structural connections in timber," *International Journal of Adhesion & Adhesives* 21(2001).

¹² P. Lavisci et al., "A shear test for structural adhesives used in the consolidation of old timber," *Holz als Roh- und Werkstoff* 59, no. 1-2 (2001).

¹³ Phillips and Selwyn, *Epoxies for Wood Repairs in Historic Buildings*.

to consolidate timber. However, they provided the following guidelines for application: exploit the end grain, avoid trapping air, prevent leakage of the epoxy, use slow curing epoxies to prevent heat buildup and take care to use compatible wood preservatives with an epoxy consolidator.¹⁴ Unfortunately, Phillips and Selwyn did not conduct extensive weathering tests or load tests on their consolidated samples as it appeared they were primarily concerned with the effect that epoxy consolidation would have on the durability of painted surfaces.

Munnikendam (1972) explored the dilution of mono-functional and bi-functional epoxy compounds in order to lower the viscosity of epoxies and thereby improving flow and penetration into the wood and improving consolidation. Mono-functional epoxy compounds have only one epoxide group while bi-functional epoxies have two. Because mono-functional epoxy compounds only have one reactive epoxide group, they are unable form cross links. Thus Munnikendam concluded that mono-functional dilution compounds reduce the cured strength of the epoxy if the dilution with mono-functional epoxy compounds is greater than 10% by volume.¹⁵ He did, however, find the best success using a bi-functional dilution compound mixed with both a slow-curing amine agent and a flexible plasticizer. Neither Phillips and Selwyn nor Munnikendam tested the effects of weathering, humidity, wood moisture content, or consolidation depth of the epoxy resins. Stumes (1971) stated that it is "very difficult to saturate woods with epoxy" and "equally difficult to measure the uniformity of saturation."¹⁶ However, Sadd and Curran (1982) tested the effect of epoxy impregnation of wood on its Mode I fracture toughness. In fracture mechanics there are three modes of failure with regards to fracture toughness. Mode I toughness deals with tensile forces perpendicular to the crack;

¹⁴ Ibid.

¹⁵ R. A. Munnikendam, "Low Molecular Weight Epoxy Resins for the Consolidation of Decayed Wooden Objects," *Studies in Conservation* 17, no. 4 (1972).

¹⁶ Stumes, "The Application of Epoxy Resins for the Restoration of Historic Structures," 63.

Mode II deals with resistance to crack opening under shear forces; and Mode III deals with resistance to crack opening with tearing forces. Materials with high fracture toughness will resist crack opening whereas low fracture toughness denotes very little resistance to crack propagation. They concluded that epoxy consolidation at the leading edge of a crack increased the fracture toughness, or the resistance to opening, of the crack.¹⁷ However, these tests were only limited to Mode I failure.

Epoxy Resin as a Structural Gap-Filling Adhesive

The use of gap-filling and prosthetic epoxy repairs for historic timber began in the early 1970s and remains in use. Wheeler and Hutchinson (1998) summarized the available techniques by repair situation as follows: (1) beam end repair, (2) trussed rafter and foot repair, (3) column repair, (4) fissure repair, and (5) upgrading beam.¹⁸

Early use of epoxy for augmenting structural wood elements was codified by Paul Stumes in the Association for Preservation Technology (1979) publication on the Wood Epoxy Reinforcement (WER) method, which was developed from the testing Stumes conducted on wood epoxy reinforcement systems in the early 1970s.¹⁹ Klapwijk's (1975) BETA method for restoring a beam was developed and patented in the same period as the WER method. Stumes' WER method presented techniques for beam end repair as well as for upgrading the structural capacity of the beam by means of embedded rods or flitch plates. Klapwijk's BETA method was limited to the repair of beam ends and accomplished this through the replacement of decayed wood with cast epoxy and embedded rods to transfer the loads between new cast epoxy and

¹⁷ Martin H. Sadd and Daniel R. Curran, "Mode I fracture toughness of epoxy impregnated wood," *Mechanics Research Communications* 9, no. 5 (1982): 334.

¹⁸ Wheeler and Hutchinson, "Resin repairs to timber structures," 6.

¹⁹ Paul Stumes, "Testing the Efficiency of Wood Epoxy Reinforcement Systems," *Bulletin of the Association for Preservation Technology* 7, no. 3 (1975).

remaining sound wood.²⁰ The use of epoxy mortar to reconstitute beam ends was also examined by Van Gemert and Bosch in the 1980s. They found that bond strength between the epoxy and wood depended on the moisture content of the wood and even stated that “the bond between wood and epoxy mortar is limited and generally does not reach the cohesion strength of the wood.”²¹ Based on their findings, they questioned the durability of epoxy/wood bonds under varying temperature and humidity and recommended such repairs only be “executed with a sufficient degree of safety.”²² Interestingly, from the field of object conservation, Grattan and Barclay (1988) recommended that “the surface of the wood to be filled is always coated to allow easy removal of the filler should the need arise.”²³ Apparently driven by the desire for reversibility of the repair, this recommendation almost immediately calls into any question the effectiveness of the bond between wood and epoxy, without which such a repair would be rendered useless in a load-bearing application.

The Durability of Epoxy Repairs

All of the previously cited literature on the epoxy repair of wood raises the question of durability. In order to address this question, Richard Avent published his results in the late 1980s and early 1990s. In one of his first studies regarding the weathering of epoxy-repaired timber, Avent tested two types of weathered joints, sound timber joints that were repaired with epoxy and also weathered wood joints that were repaired with epoxy concluded that “in both

²⁰ Dick Klapwijk. Method of Restoring a Wooden Beam. United States Patent 3,900,541, filed June 18 1975, and issued August 19,1975.

²¹ D.;Vanden Bosch Van Gemert, M., "Structural restoration of wooden beams by means of epoxy resin," *Materials and Structures* 20(1987).

²² Ibid.

²³ D. W. Grattan and R. L. Barclay, "A Study of Gap-Fillers for Wooden Objects," *Studies in Conservation* 33, no. 2 (1988).

cases, the epoxy repair responded well.”²⁴ Although he also stated that “when practical, it usually better to replace seriously weathered and decayed timber.”²⁵ A couple of years after his study on the effects of weathering, he published research regarding the factors affecting the strength of epoxy repaired timber. He concluded in this study that the parallel grain shear strength of the wood, lap length and grain orientation had the greatest effect on the strength of epoxy bonded members.²⁶ In the same year Aven also published design criteria in order to aid engineers compute the actual stresses and the allowable stresses after repair. More recently, Custódio, Broughton et al. (2009) published their review of factors affecting the durability of bonded joints in timber. They summarized a bonded joint essentially a “system of layered interfaces, all of which respond in different ways to externally applied load and environmental conditions .”²⁷

Summary and Thesis

Over the past 40 years various researchers have been studying the compatibility of epoxy and wood repairs. A review of the literature indicates that the durability of epoxy-repaired timber has not been rigorously assessed since its introduction to the field of preservation of timber structures. The lack of assessment of the long-term performance of epoxy-repaired timber and the significant differences between the properties of wood, a hygroscopic organic material, and those of epoxy, an impermeable plastic should raise concern. The question of mechanical compatibility of the two materials has been researched, but there are disconcerting results of the effects of temperature and moisture on epoxy’s bulk properties. This thesis sets to examine

²⁴ R. Richard Aven, "Decay, Weathering and Epoxy Repair of Timber," *Journal of Structural Engineering* 111, no. 2 (1985): 340.

²⁵ Ibid.

²⁶ R. Aven, "Factors Affecting Strength of Epoxy-Repaired Timber," *Journal of Structural Engineering* 112, no. 2 (1986).

²⁷ João Custódio, James Broughton, and Helena Cruz, "A review of factors influencing the durability of structural bonded timber joints," *International Journal of Adhesion and Adhesives* 29, no. 2 (2009).

this adhesive relationship between wood and epoxy in order to answer this question of compatibility based on the current knowledge. In order to accomplish this task, the thesis focuses on the structural compatibility of these two materials. Furthermore, it narrows the wood species in question to white oak, American chestnut, and southern yellow pine or those determined by Hoadley as being the dominant species used in historical structural timber elements in the United States.

Chapter 2 –Historic Timber Restoration and Epoxy Repairs

“Where traditional techniques prove inadequate, the consolidation of a monument can be achieved by the use of any modern technique for conservation and construction, the efficacy of which has been shown by scientific data and proved by experience.” – Article 10, The Venice Charter 1964

The use of epoxy in the restoration of structural properties of deteriorated structural timber elements is only one of the several repair options available. Other repair methods include replacement in kind with new timber, substitution of the timber with new material such as steel, and circumventing the load path by the insertion of a new structural support system. The debate for the or against their use in timber structures stirs strong opinions about their appropriateness and durability that polarizes architects, engineers, craftsmen, and preservationists. The professional attitudes towards epoxy repair methods reflect its lack of acceptance as a modern repair method combined with a healthy dose of skepticism with regards to its long term performance. Although epoxies were first developed in the 1930s, it was not until 1958 that Gougeon Brothers, Inc. introduced epoxy resins into the wood industry as structural adhesives.^{28,29} However, it was not until the 1971 that conservation professionals, such as Elizabeth Schaffer and Paul Stumes, began to test their use in historic timber structures.^{30,31} By 1994, epoxy use in historic timber structures distressed the professional preservation community so much that ICOMOS specifically adopted the following principle at the 12th General Assembly,

“Contemporary materials, such as epoxy resins, and techniques, such as structural steel reinforcement, should be chosen and used with the greatest caution, and only in cases where the durability and structural behavior of the materials and construction techniques have been satisfactorily proven over a sufficiently long period of time.”

²⁸ Meade Gougeon, *The Gougeon Brothers on Boat Construction: Wood and West System Materials*, 5th ed. (Bay City, Michigan: Gougeon Brothers, Inc., 2005). 1.

²⁹ Pham, "Epoxy Resins."

³⁰ E. Schaffer, "Consolidation of Softwood Artifacts," *Studies in Conservation* 16, no. 3 (1971).

³¹ Stumes, "The Application of Epoxy Resins for the Restoration of Historic Structures."

Despite this cautionary note, there are preservation professionals who continue to promote its use and thus continue to test its performance over time and under adverse conditions to determine its effectiveness.

Options for Structural Repair of Historic Timber

Repair of structural timber can be broken down into six different approaches:

Abstention, Mitigation, Reconstitution, Substitution, Circumvention, and Acceleration.³²

Abstention is straightforward and means electing to not undertake any repair.³³ Mitigation includes attempts alter the environment supporting the deterioration mechanism.³⁴ Mitigative treatments focus on the environment and not on the actual structural element, and may include actions such as attempting to control the relative humidity or removing a structural load.

Reconstitution focuses on the replacing the fabric of the timber element “in kind, size and location.”³⁵ Under this repair approach the decayed or failed element is removed and replaced with timber. Substitution, on the other hand, is “the direct replacement of a material with another material for the purposes of enhancing its performance.”³⁶ This approach aims to reestablish of the load capacity of the original member, but with a new and possibly different material. Epoxy repairs of historic structural timber typically fall under the approach of substitution. Circumvention requires focuses on changing “the manner in which the original material functioned” and thus disregards the both the original material and its structural performance.³⁷ This approach entails the installation of new structural support to completely or

³² Samuel Y. Harris, *Building Pathology : Deterioration, Diagnostics, and Intervention* (New York: J. Wiley, 2001). 39-40.

³³ *Ibid.*, 40.

³⁴ *Ibid.*, 41.

³⁵ *Ibid.*, 42.

³⁶ *Ibid.*

³⁷ *Ibid.*, 43.

partially bypass the original member. In effect, this option allows the timber member to remain in its current state while redirecting the load path. The last type of approach, acceleration, includes the structural demolition and essentially entails “doing a controlled manner what will happen in an uncontrolled and potentially catastrophic, dangerous manner.”³⁸ This approach aims to prevent harm to the public when a structure or element has been declared structurally unsafe and no resources are available for repair. Based on its finality, this approach is typically resisted with historic structures. The selection of the appropriate approach from the above listed options is dependent upon of the desired level of authenticity, intervention, reversibility and durability .

Conservation Guidance and Timber Repairs

The authenticity of an object is derived from the credibility and truthfulness it imparts as an information source of the values attributed to a particular cultural heritage. Values associated with historic timber are primarily attributed to their aesthetic, historic and age values. Specifically, as noted by Graham, historic timber is valued for its (1 patina and aesthetic, (2) color/finish, (3) markings and symbols, (4) joinery, (5) age (as determined by dendrochronology) . As discussed above, the degree of intervention with an historic structure can range from full dismantling to repairing in situ . The acceptable level of intervention is typically a function of desired authenticity, budget and the guiding conservation philosophy for the historic resource as a whole. From proceedings of the 12th General Assembly on historic timber structures, the International Council on Monuments and Sites (ICOMOS) recommends that “any proposed intervention should (i) follow traditional means, (ii) be reversible, (iii) at least not prejudice or impede future work whenever this may be necessary and (iv) not hinder

³⁸ Ibid., 44.

the possibility of later access to evidence incorporated in the structure.”³⁹ ICOMOS also encourages that all interventions should consider the timber structure as a whole and “that the minimum intervention in the fabric of a historic structure is ideal.” In contrast, they recognize that sometimes the minimum intervention sometimes requires partial or full dismantling and reinstallation. The ideal intervention is fully reversible; however, a fully reversible repair is very difficult to achieve in practice. Furthermore, ICOMOS recommends that materials such as epoxy resins should “be chosen and used with greatest caution and only in cases where the durability and structural behavior of the materials ...have been satisfactorily proven.”⁴⁰ Thus reversibility along with authenticity, degree of intervention and durability are criteria that guide the selection of the repair approach.

Taking into account the aforementioned approaches and conservation guidance applied, the available types of repair options can be compared. Table 1 compares the repair approaches with the conservation guidance and provides some context for the choice of repair types. Comparing and analyzing the different repair approaches based on the four aforesaid guidance favors methods such as either reconstitution or circumvention as those methods are able to achieve a consistent and high degree of authenticity, reversibility, and durability. Abstention and acceleration, as noted above, are generally not considered because they preservation focused. Epoxy repairs, which fall under the substitution approach, are typically approached with caution due to the lack of consistency when it comes to taking into account the guidance criteria. For example, they are not reversible and, as discussed in the first chapter, their functional performance and durability has not been rigorously assessed to provide to be considered satisfactorily proven. This thesis focuses on rigorously assessing epoxy repairs to

³⁹ International Council on Monuments and Sites, "Principles for the Preservation of Historic Timber Structures" (paper presented at the 12th General Assembly, Mexico, 1999).

⁴⁰ Ibid.

structural historic structural timber with respect to the current state of the art and as such it is focused on the substitution repair approach.

<u>Conservation Guidance</u>					
Repair Approaches		<i>Authenticity</i>	<i>Reversibility</i>	<i>Level of Intervention</i>	<i>Durability</i>
	<i>Abstention</i>	High	N/A	N/A	Low
	<i>Mitigation</i>	High	N/A	N/A	Medium
	<i>Reconstitution</i>	Medium	High	Medium	Medium
	<i>Substitution</i>	Varies	Varies	Varies	Varies
	<i>Circumvention</i>	High	High	High	High
	<i>Acceleration</i>	Low	Low	High	N/A

Table 1: Comparison of Repair Approach and Conservation Criteria

The Development and Types of Epoxy Repairs for Historic Structural Timber

From their development in the 1930s, epoxy resins were introduced into a variety of industries, including as construction, aerospace and electronics industries.⁴¹ As epoxies came into use for fabrication of wooden boats, preservation professionals took notice and investigated epoxy repair methods for historic structural timbers in the 1970s. From the early introduction of epoxy as a structural adhesive in the wooden boat-building industry, today use of epoxy for structural timber repair have expanded and can be categorized as a consolidant, structural adhesive, or structural gap-filling adhesive.

Epoxy as a Structural Adhesive

The development of the West System® by the Gougeon Brothers, Inc. is one of the earliest applications of epoxy in the wood industry. Jan and Meade Gougeon were introduced

⁴¹ Pham, "Epoxy Resins," 157-58.

to epoxy when Jan apprenticed under Vic Carpenter as a boat builder in 1958. By the 1960s, they experimented with epoxies in wood fabrication, and although they experienced mixed results, they were impressed by epoxy's ability to bond with wood, metal, and fiberglass reinforcement. The possible advantages were sufficient that the brothers continued to work with epoxy. Eventually, working with Dow Chemical Company, they developed their own epoxy formula for use as a water-resistant coating for their boats.⁴² Shortly after the Gougeon brothers introduced their product on the market other professionals, such as Canadian structural engineer Paul Stumes, began exploring the use of the as a repair strategy for timber elements.

As Paul Stumes began publishing his tests on the W.E.R. system, a reinforcing beam with epoxy embedded steel was not thought to be necessarily economical. Tivadar Szabo, in discussion with Paul Stumes, developed an alternative method in which plywood would serve as the reinforcement.⁴³ In this variation, a dado is cut into the decayed wood and a piece of one-half inch thick plywood is inserted and adhered to the original member with epoxy (Figure 1). The beam is then capped with more plywood, which is also adhered via epoxy. This method is attractive in comparison to the W.E.R. method because it reduces the amount of structural epoxy adhesive as well as replaces costly tensile reinforcement. Szabo's testing reported that such a method increased the modulus of elasticity by 22% and modulus of rupture by 17.7% and therefore concluded that "this plywood design may be considered" in actual application.⁴⁴

⁴² Gougeon, *The Gougeon Brothers on Boat Construction: Wood and West System Materials*: 2.

⁴³ T. Szabo, "Plywood Reinforcement for Structural Wood Members with Internal Defects," *Bulletin of the Association for Preservation Technology* 9, no. 1 (1977): 12.

⁴⁴ *Ibid.*, 15.

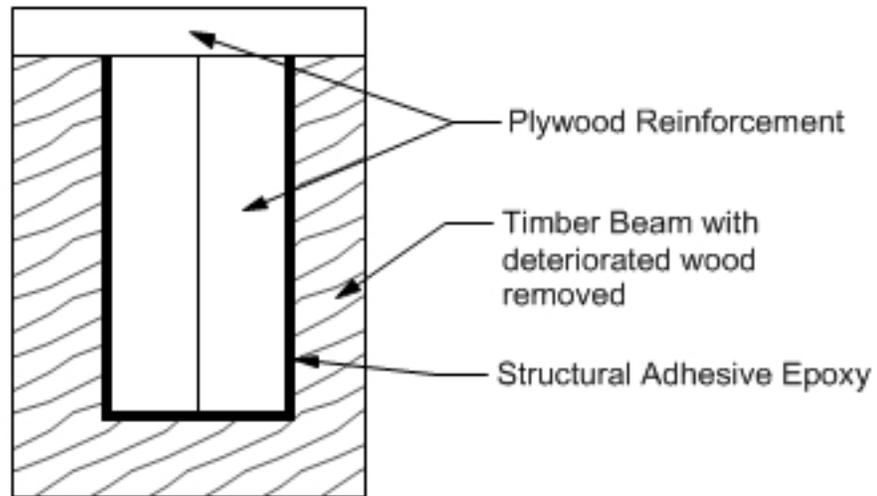

Figure 1: Plywood Reinforcement of a Deteriorated Beam with Structural Epoxy Adhesive

In 1999, a technique called Resin Bonded Timber Repair was developed the Weald and Downland Open Air Museum in the United Kingdom and has subsequently been implemented with reported success. In this method, the deteriorated timber's veneer is salvaged and adhered to new structural timber and replaces the old timber. Thus, the principle of the resin bonded timber repair "is to splice in sufficient timber behind the historic timber surfaces to restore structural performance." . This repair is interesting because the authenticity of the visible surface of a timber member can be preserved (Figure 2).

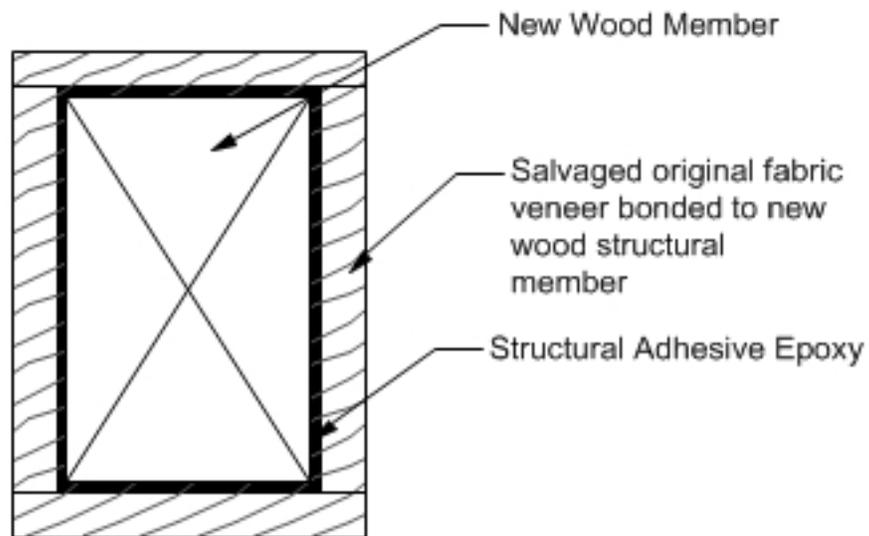

Figure 2: Resin-Bonded Timber Repair. The thick veneer of the original fabric is preserved and adhered to a new structural piece of wood. Method attempts to preserve authenticity of the member by retaining its visible surfaces while replacing the deteriorated timber with a new piece of structural timber.

Epoxy as a Consolidant

While building professionals were experimenting with epoxies as gap-filling adhesives, objects conservators had already begun to explore the possibilities of epoxies for wood consolidation. Wood consolidants fill the voids in decayed timber and thus restore all the mechanical properties of the original piece to some extent. Paul Stumes was introduced to the possibilities epoxy resins through Erika Schaffer, a conservation chemist.⁴⁵ Prior to the testing of epoxies as consolidants, a number of other materials were used as consolidants such as animal glue, molten wax, drying oil and natural resin. In 1971, Schaffer tested a low viscosity epoxy manufactured by Union Carbide; she diluted the resin with 10% butyl glycidyl ether and applied it to pine wood and was able to satisfactorily conclude that “depending on the size of the object

⁴⁵ Stumes, "The Application of Epoxy Resins for the Restoration of Historic Structures," 59.

and the depth of the decayed area, the composition of the liquid can be chosen ... that the required penetration, and thus consolidation, will be attained.”

In 1978, epoxy’s potential as consolidant was explored by Dr. Judith Selwyn and Morgan Phillips as part of a commission they received from U.S. Department of the Interior. Their study aimed to “present the results of a preliminary research and testing program on epoxy consolidants and patching compounds.” As a basis of their evaluation, they determined that a satisfactory architectural wood consolidant shall (i) exhibit low shrinkage, (ii) have a controllable curing mechanism, (iii) be durable, (iv) be reversible, (v) have adjustable strength properties, (vi) exhibit a low viscosity, (vii) be of a low toxicity and (viii) be able to retain paint . As a consolidant, the epoxy resin and hardener impregnate the wood by filling the voids; however, because epoxies they begin to cure as soon as they are applied which limits the depth of penetration. Because of this, low viscosity epoxies are desirable and diluents are typically added to extend the curing time and thereby maximizing the depth of impregnation of the epoxy consolidant.⁴⁶

Epoxy as a Structural Gap-Filling Adhesive

The third category of epoxy repairs to historic structural timber is as a gap-filling adhesive. In this type of repair, cast epoxy serves as an integral, large volume, cast-in-place part of the timber element. This category of repair is best represented by both the W.E.R and BETA Systems. Paul Stumes, in 1971, wrote that “the discovery of the new synthetic resins in the past decade changed the technology of wood restoration decisively.” He attributed his exposure to epoxy resins to Erika Schaffer, a conservation chemist from the National Museum of Canada that was testing the viability of epoxy resins as a wood consolidant. Stumes saw great potential

⁴⁶ Schaffer, "Consolidation of Softwood Artifacts," 110-11.

in epoxy further by lauding its potential as a “preservative, a structural stabilizer, a protective coating, a paint substrate, artificial wood, etc., with no other limit but our own resourcefulness.” Encouraged by potential, Stumes led research and testing throughout the 1970s in order to determine the weak points of reinforcing timber with epoxy and to establish design parameters for other engineers and restoration professionals.

At this point, Stumes had already conceived the W.E.R (Wood Epoxy Reinforcement) system as a valid repair methodology. The W.E.R system, as he described it, was “the replacement of the disintegrated parts of the wood with epoxy resin, and reinforcement with high tensile inserts.” The high tensile inserts conceived by Stumes included rebar, metal plate and fiberglass rods. By 1979, Stumes published the W.E.R System Manual detailing several variations of a W.E.R repair. The manual not only detailed the repairs but provided engineers with a methodology to calculate the required size and amount of tensile reinforcement needed. In his manual, Stumes described the role of epoxy as two-fold, (i) replacement of decayed wood and (ii) adhesive between wood and reinforcement material. Although he claimed that the epoxy had two to three times the strength of wood and thus made a good replacement material, the additional strength was not accounted for in his calculations. Based on the design methodology, the epoxy functioned as structural gap-filling adhesive between a new piece of embedded structural reinforcement and sound wood as depicted in Figure 3.

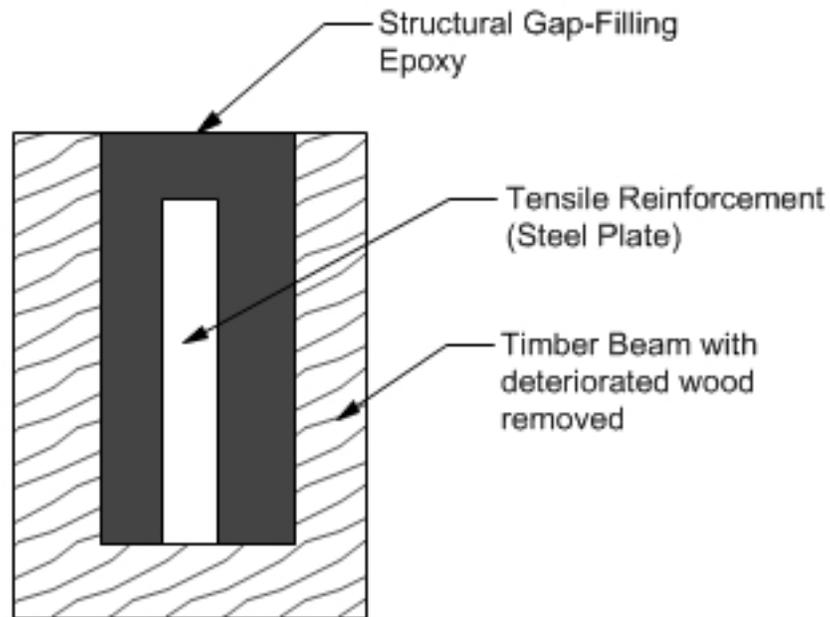

Figure 3: Wood Epoxy Reinforcement System Repair with Steel Plate Tensile Reinforcement

In the BETA system repair, developed in the Netherlands by Dick Klapwijk, the decayed and rotten end of a member is removed and replaced with cast epoxy that is tied to the sound wood by means of reinforcing rods comprised of either steel or fiberglass. Although the epoxy also doubles as an adhesive around the reinforcing bars, a large section of cast epoxy forms the bearing surface for the repaired beam. The BETA system and the W.E.R. system are very similar in approach. The W.E.R. provides two things that the BETA system does not. First, it covers several repair situations including the replacement of the middle and end sections of a structural beam. Additionally, the W.E.R. provided designers with quantitative way in which to calculate the required tensile reinforcement. The BETA system focused primarily on replacing a beam end with a standard design (Figure 4)

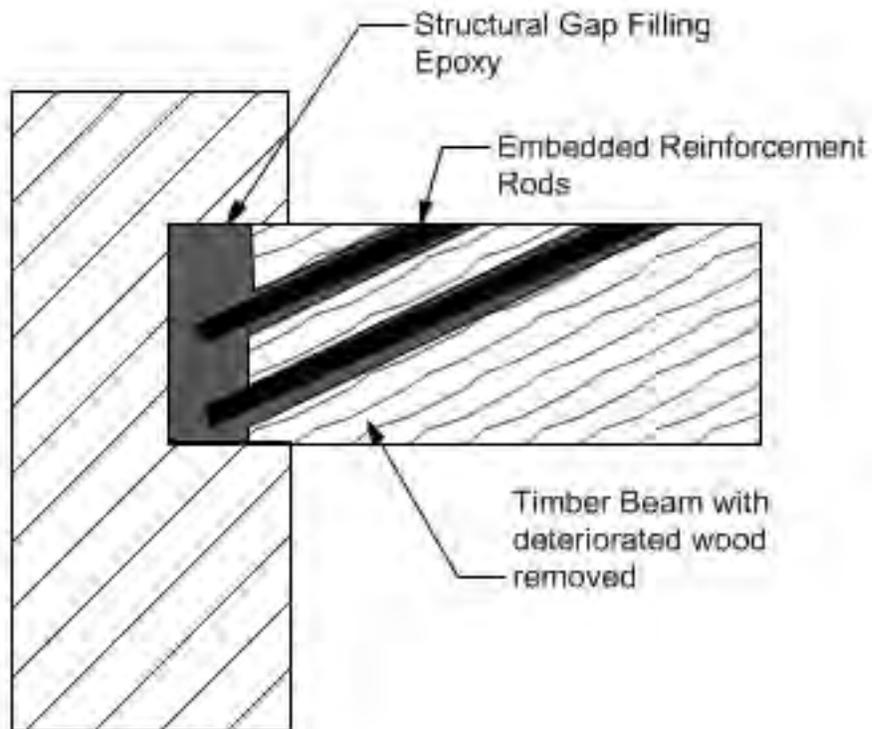

Figure 4: BETA System Epoxy Repair

Interestingly, Klapwijk, a plastics research chemist, invented this repair system because of issues he experienced during the restoration of his own home in Brielle, Netherlands in the early 1970s. Shortly after he had purchased his home he quickly discovered that it was in need of stabilization as the majority of the enormous wooden roof beams had rotten ends. At that time, he did not want to proceed with the costly removable and replacement of the beam ends with new wood, so by combining his knowledge of plastics and epoxies his BETA system was conceived and then patented.⁴⁷

⁴⁷ Dick Klapwijk, "Bureau Beta, Restoration techniques in the plastic age," *Netherlands American Trade*, no. November (1977): 11.

Chapter 3 –Material Composition and Properties: Wood

Timber is a building material that has been long valued for its comparable strength in both tension and compression which gives it the distinction of being one of the only natural building materials suitable for use in beams. However, its mechanical properties vary significantly by species, grade, moisture content, and grain orientation. With regard to epoxy-wood repairs, Paul Stumes recommended epoxies because they could be easily and safely transported, it could be applied with simple utensils, and “epoxy can perform a wide variety of tasks” including use as a “preservative, a structural stabilizer, a protective coating, a paint substitute, artificial wood, glue, etc., with no other limit but our own resourcefulness.”⁴⁸ Ultimately, the compatibility of wood with adhesive-bonded materials such as epoxies requires the mechanical, physical, and surface properties of wood to be examined in detail. The scope of this thesis is limited to the species to white oak, American chestnut and southern yellow pine, which were the species of wood primarily used in framing of historic timber structures in the United States.⁴⁹

The following sections of this chapter present the wood’s composition and its aforementioned properties. The last section of this chapter presents these properties as they apply to the aforementioned historic timber species under consideration.

Wood Composition

The basic building block of all species is the wood cell, which is typically comprised of a cell wall and cell cavity.⁵⁰ The arrangement and chemical composition of the wood cells impart the overall physical and mechanical properties of the wood member. A wood cell can be described

⁴⁸ Stumes, "The Application of Epoxy Resins for the Restoration of Historic Structures," 59.

⁴⁹ Hoadley, *Identifying wood : accurate results with simple tools*: 178.

⁵⁰ *Ibid.*, 7. The discussion of wood composition does not include a discussion of the gross anatomical features such as growth rings. The reader is directed to the cited sources for a detailed discussion on such macro identification features and their significance.

in the context of its three components: a middle lamina, a primary wall, and three layers comprising the secondary wall (Figure 5), all enclosing a space referred to as the lumen.

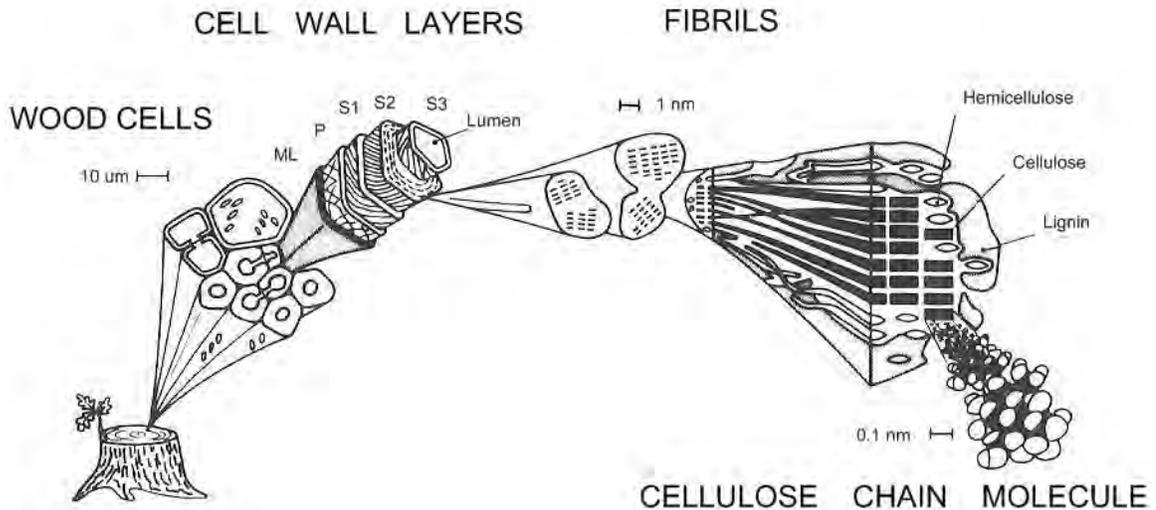

Figure 5: Physical structure and composition of a wood cell. The cell wall is comprised of a middle lamina (ML), which separates individual cells; a primary wall (P) and a secondary wall made up of three layers (S1, S2, S3). Fibrils comprise the cell walls. Cellulose orientation and wall thickness varies between layers depending on the orientation and volume of fibrils present. The hemicellulose and cellulose are bound together with lignin. (Source: Chapter 2, *Archeological Wood*; Original figure redrawn by author for clarity)⁵¹.

Chemical Composition. Cellulose, hemicellulose and lignin are the primary chemical compounds that comprise the fibrils which make up the wood cell layers. The content of each of these chemical compounds varies based on the tree genus and species and the cell's location within the tree (i.e. latewood/earlywood, heartwood/sapwood). Cellulose and hemicellulose, organic polymers of sugars, make up the carbohydrate content of the wood, with values typically ranging between 55-65% by volume of the wood cell.⁵² Lignin, another highly complex organic

⁵¹ Per Hoffmann and A. Jones Mark, "Structure and Degradation Process for Waterlogged Archaeological Wood," in *Archaeological Wood, Advances in Chemistry* (American Chemical Society, 1989). An in-depth discussion of wood chemistry is outside the scope of this thesis but the reader is directed to the cited source for detailed chemical content and descriptions of the types of lignin, cellulose and hemicellulose found in wood cells.

⁵² Forest Products Laboratory (U.S.) and Benjamin Franklin Library Fund., *Wood handbook : Wood as an Engineering Material*, 1 vols., General Technical Report (Madison, WI: Forest Products Laboratory ; Madison Washington, D.C. : Supt. of Documents, U.S. GPO, 2010).

polymer, bonds the cellulose and hemicellulose together. Lignin comprises approximately 20-30% by volume of the wood cell.⁵³ Figure 6 depicts the molecular relationship among the hemicellulose, cellulose and lignin within the fibrils that comprise the cell walls.

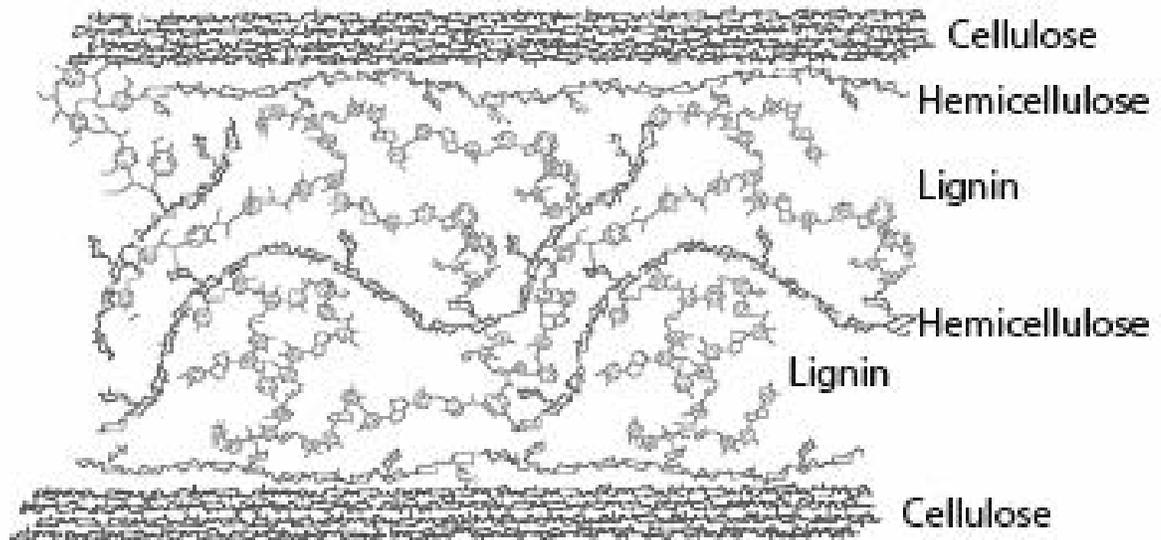

Figure 6: Chemical composition of a cell wall (Source: *Journal of Cultural Heritage*, 2012)⁵⁴

Finally a small percentage of extractives are found in the wood cell's lumens and are primarily responsible for the distinctive color, smell and durability (resistance to decay) of a species.⁵⁵

Wood Properties

Mechanical Properties

Because wood is an orthotropic material, its mechanical properties vary with each of its principal orthogonal directions; longitudinal, radial, and tangential (Figure 7). The mechanical properties vary in value depending on whether the wood is loaded parallel or perpendicular to

⁵³ Ibid.

⁵⁴ Nilsson and Rowell, "Historical wood – structure and properties," 58.

⁵⁵ Roger M. Rowell, *Handbook of wood chemistry and wood composites* (Boca Raton, Fla.: CRC Press, 2005). 53. An in-depth discussion of wood chemistry is outside the scope of this thesis but the reader is directed to the cited source for detailed chemical content and descriptions of the types of lignin, cellulose and hemicellulose found in wood cells.

the grain (or fiber direction). The major mechanical properties that are considered include: tensile strength, compressive strength, shear strength, flexural strength, the modulus of elasticity and the shear modulus. All units of measurement regarding properties are reported in the US customary units.

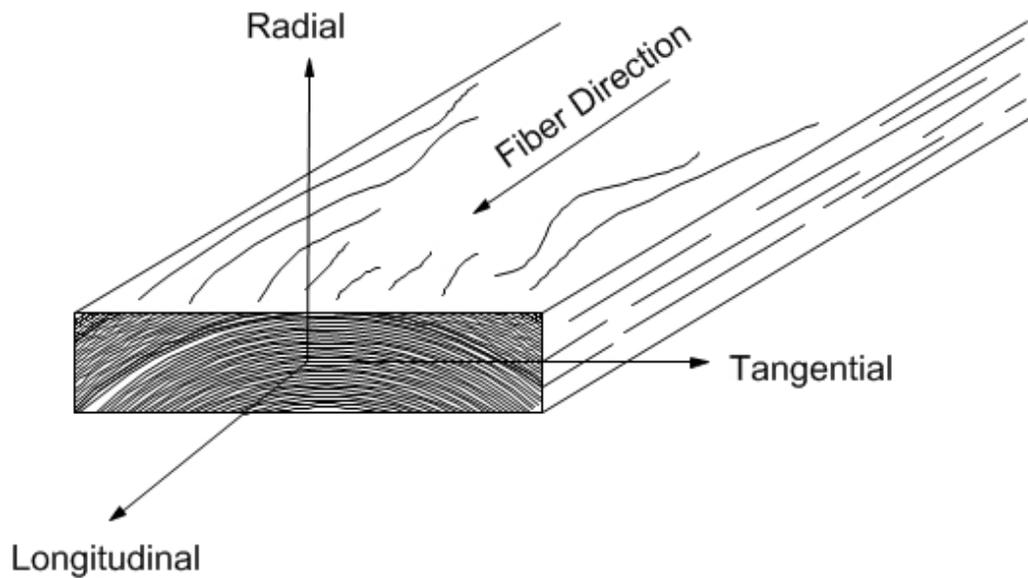

Figure 7: The three principal and orthogonal axes of wood. (Source: *Wood Handbook: Wood as an Engineering Material*; Redrawn by author for clarity)⁵⁶

Tensile Strength. The tensile strength of wood is defined as its resistance to opposing forces that act in one direction away from each other that tend to split or pull the wood apart. Wood's tensile strength parallel to the grain is one of its strongest properties while its tensile strength

⁵⁶ Forest Products Laboratory (U.S.) and Benjamin Franklin Library Fund., *Wood handbook : Wood as an Engineering Material*: 5-1.

perpendicular to the grain is one wood's weakest.⁵⁷ It is expressed as pounds per square inch (psi) and determined in accordance with ASTM 143(Standard Test Methods for Small Clear Specimens of Timber).

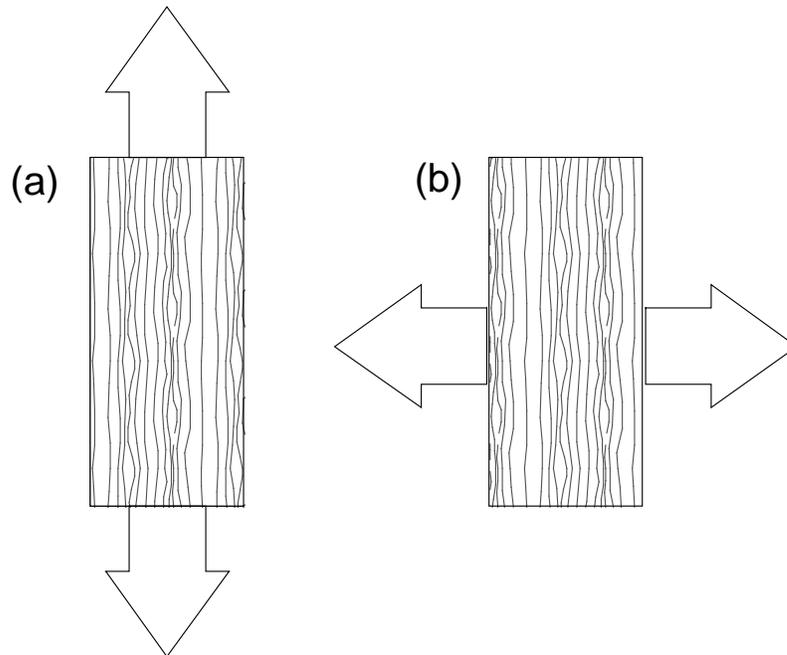

Figure 8: (a) Tensile load parallel to the grain (b) Tensile load perpendicular to the grain

Compressive Strength. The compressive strength is defined as its resistance to opposing forces that act in one direction toward each other and tend to crush the wood. Like the tensile strength, the compressive strength is expressed in terms of pounds per square inch (psi) and determined in accordance with ASTM 143 (Standard Test Methods for Small Clear Specimens of Timber).

⁵⁷ Faherty, Williamson, and Harry E. Humphreys Book Fund., *Wood engineering and construction handbook*: 1.14.

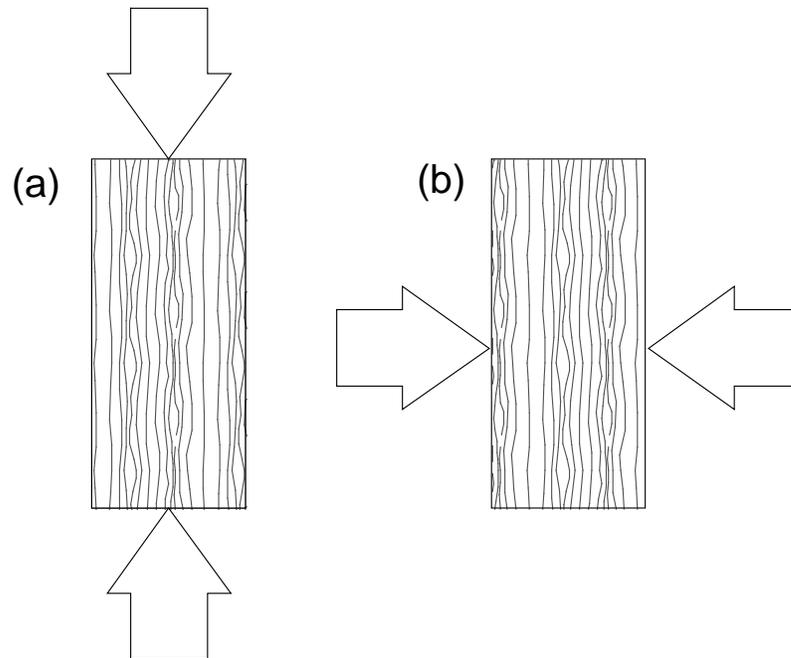

Figure 9: (a) Compressive load parallel to the grain (b) Compressive load perpendicular to the grain.

Shear Strength. Shear strength is defined as wood's resistance against internal slippage along a plane parallel to the direction of loading. Shear strength of a wood across the grain is not considered in design, because shear failure will always occur parallel to the grain.⁵⁸ Again it is expressed in pounds per inch (psi) and determined in accordance with ASTM 143 (Standard Test Methods for Small Clear Specimens of Timber).

⁵⁸ Ibid., 1.15.

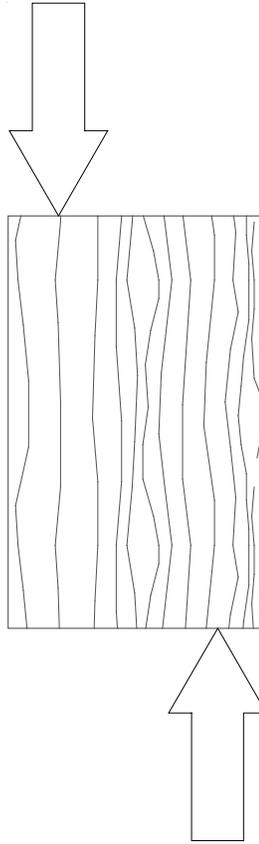

Figure 10: Shear load parallel to the grain.

Flexural Strength. Flexural strength is defined as resistance to bending loads and is also known as the modulus of rupture. Flexural strength values are limited to the elastic range of deformation under load.⁵⁹ It is expressed in pounds per square inch (psi) and determined in accordance with ASTM 143 (Standard Test Methods for Small Clear Specimens of Timber).

⁵⁹ Forest Products Laboratory (U.S.) and Benjamin Franklin Library Fund., *Wood handbook : Wood as an Engineering Material*: 5-3.

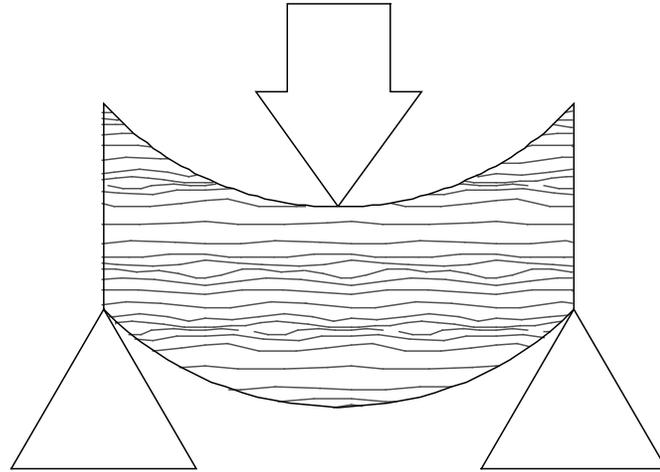

Figure 11: Flexural load

Modulus of Elasticity. The modulus of elasticity (E) is the relationship of load to deformation within the elastic range of a material. The elastic region is the range in which the material will return to its original position once a load is removed. Because of wood's orthotropic nature, there are three moduli of elasticity associated with any given species. Wood experiences a unique condition called creep. Thus the unlike isotropic materials, like steel, it will continue to deform under a long term load yielding permanent deformation.⁶⁰ The modulus of elasticity is the ratio of the axial stress over strain and expressed in kips per square inch (ksi). The three moduli of elasticity are determined from the compressive tests in accordance with ASTM 143 (Standard Test Methods for Small Clear Specimens of Timber).

Shear Modulus. The Shear Modulus represents the resistance to deflection due to shear forces. Like the modulus of elasticity, there are three shear moduli per wood species, one per orthogonal axis. The shear modulus is also referred to as the modulus of rigidity (MOR). Qualitatively, the shear modulus is the ratio of shear stress to strain and typically expressed in

⁶⁰ Faherty, Williamson, and Harry E. Humphreys Book Fund., *Wood engineering and construction handbook*: 1.15.

pounds per square inch (psi). The shear modulus parallel to the grain is calculated from the results of the shear strength; while the tangential and radial shear moduli are typically calculated using the respective modulus of elasticity.

Physical Properties

Density & Specific Gravity. The density of a material is defined as the ratio of the mass to the volume. Specific Gravity, typically denoted by G or SG, is typically calculated as the oven-dry mass to the volume of the material normalized by the density of water. However, because wood's volume and mass depend on its moisture content, as reference values for density are typically reported for the following moisture contents of a species: oven-dry(0%), green(30%) and 12% moisture content. It is also important to note that other factors such proportion of a latewood to earlywood and presence of juvenile wood can affect density within the same species. In general, however, higher density woods have a greater amount of wood cells and less cell cavity space.

Coefficient of Thermal Expansion. Wood, like other materials, expands when heated and contracts when cooled. The rate at which this expansion and contraction occur is expressed in the coefficient of thermal expansion. CoTE values parallel to the grain typically range from 1.7 to 2.5 X10⁻⁶ in per degree Fahrenheit.⁶¹ Like its mechanical properties, the CoTE varies with each orthogonal axis. The CoTE in the radial and tangential directions is proportional to the oven-dry specific gravity of the wood and related by the following equations⁶²:

$$\text{Radial CoTE} \quad \alpha_r = (18G_{\text{oven-dry}} + 5.5)10^{-6} \frac{\text{in}}{\text{°F}}$$

$$\text{Tangential CoTE} \quad \alpha_t = (18G_{\text{oven-dry}} + 10.2)10^{-6} \frac{\text{in}}{\text{°F}}$$

⁶¹ Forest Products Laboratory (U.S.) and Benjamin Franklin Library Fund., *Wood handbook : Wood as an Engineering Material*: 4-14.

⁶² Ibid., 4-15.

CoTE values in the radial or tangential are significantly greater than the CoTE parallel to the grain by an order of magnitude of up to 10 times. However, unless the subject timber is dry, the shrinkage and swelling that wood experiences due to changes in moisture content, rather than temperature, will dominate the magnitude of dimensional change.

Moisture Content & Dimensional Stability. As a hygroscopic material, wood absorbs water vapor from the air as well as absorbing liquid water in contact with it. It is important to recognize that the moisture content of wood directly affects its other mechanical and physical properties. However, this dimensional instability when exposed to environmental moisture does have its limits. Once all of the wood fibers (and on a molecular level the wood cells) have become saturated, no further volumetric change occurs. This point, known as the fiber saturation point, varies with species but on average is reached at a moisture content of 30%.⁶³ Any additional moisture content past this point is held as free water in the cell cavities; however, it will be limited by the volume of voids. Species with higher specific gravities have less void spaces and thus lesser maximum capacity to hold water and vice versa.

The dimensional, or volumetric, change that wood undergoes is not experienced equally amongst wood's principal orthogonal axes. Wood experiences the least volumetric change, on a magnitude of 0.1 to 0.2% in direction of the fibers, or the longitudinal axis. It experiences the greatest change along the tangential axis with the radial shrinkage and swelling roughly half of the tangential.⁶⁴ These differing rates of shrinkage and swelling among the tangential, radial and longitudinal axes result from the thickness and layer orientation of the secondary cell wall structure. The significant effects of moisture content on the mechanical properties occur at moisture contents up to the fiber saturation point in which the bound water in the cell walls

⁶³ Ibid., 4-2.

⁶⁴ Ibid., 4-5.

interfere with bonding of the organic polymers.⁶⁵ High density woods, which contain a larger number of cells per unit volume than low density woods, are more greatly affected by changes in moisture content than lower density woods.

Grain Orientation. As it applies to mechanical properties, grain refers the orientation of the fibers. Not all wood is sawn with perfectly straight grain, nor does all wood grow with perfectly straight grain. Therefore, in structural application, an important consideration is the slope of the grain of a piece of wood, because that the direction of the loading of a timber will not be parallel or perpendicular to its longitudinal axis, thus negatively affect the value of its mechanical properties. As will be discussed in Chapter 5, the slope of the grain also affects bonding performance of wood when it is adhered with another structural member.

Surface Properties.

The surface properties of a wood member play a significant role in determining how well it is able to form an adhesive bond. Surface properties can be divided into two categories: physical and chemical. The primary physical properties include morphology, roughness, smoothness, specific surface area and permeability, while their chemical properties consist of the elemental and molecular composition of the exposed or surface wood cells.⁶⁶ The timber specie is the primary factor that determines the surface properties.⁶⁷ Specifically, higher density woods have thicker cell walls and thus smaller lumen limiting the ability of adhesives to form a mechanical interlock with the wood substrate or surface. Additionally, higher concentrations of extractives tend to be found in higher density woods and may chemically interfere with the bonding⁶⁸.

However, the amount and type of extractives is a function of the timber species. Finally, the

⁶⁵ Rowell, *Handbook of wood chemistry and wood composites*: 312.

⁶⁶ Ibid.

⁶⁷ Forest Products Laboratory (U.S.) and Benjamin Franklin Library Fund., *Wood handbook : Wood as an Engineering Material*: 16-2.

⁶⁸ Ibid., 10-6.

surface finish and condition greatly affect the bond performance with adhesives by either enabling or prohibiting the flow of the adhesive into the wood cells (Figure 12).

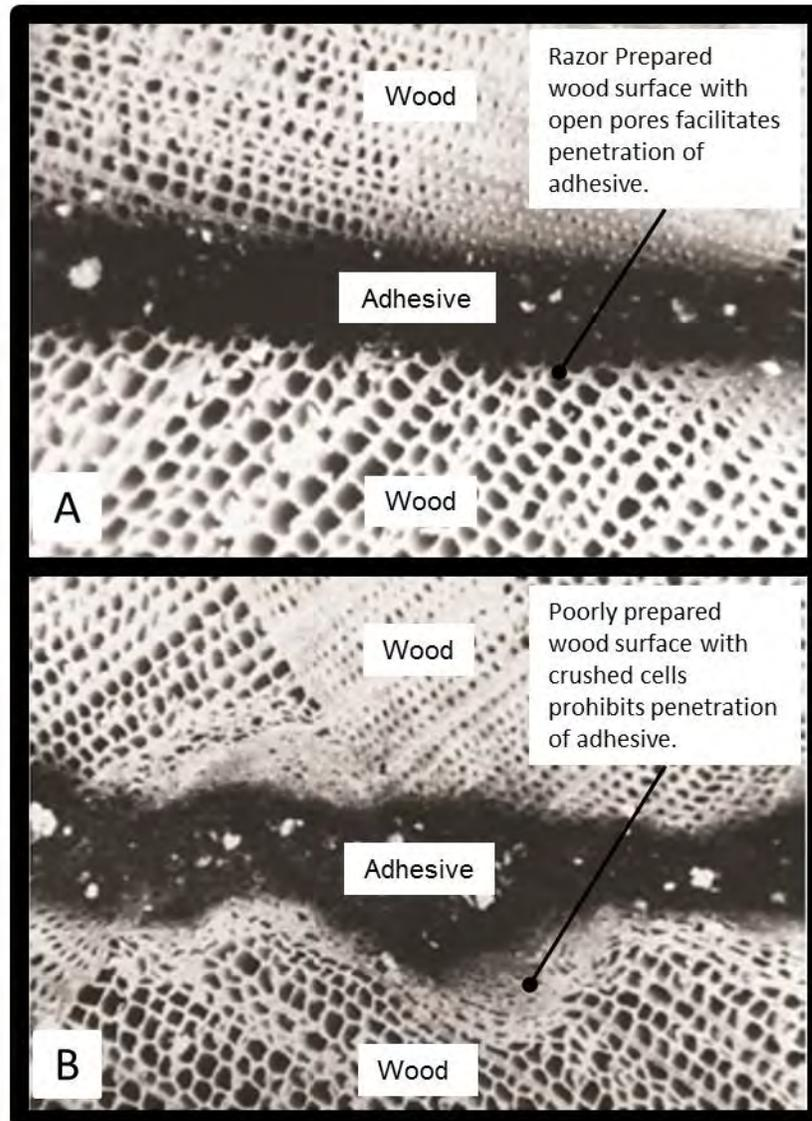

Figure 12: Adhesive Bondlines in (A) a sound wood surface and (B) a poor, crushed, wood surface. The depth of adhesive penetration is significantly affected by type of surface finish or condition. Source: Handbook of Wood Chemistry and Wood Composites, 2005⁶⁹

⁶⁹ Rowell, *Handbook of wood chemistry and wood composites*: 231.

Property Values of Historic Woods Commonly Used in Historic Structural Framing in the United States

This final section provides a summary of the mechanical and physical properties of wood species typically found in structural framing within historic structures within the United States. These property values enable a comparison of the compatibility of materials in the chapters that follow. All values were obtained using the 2012 edition of the Forest Products Laboratory's *Wood Handbook: Wood as an Engineering Material*.

Properties of Wood Species found in Historic Structures in the United States				
Wood Species	<i>Scientific Name</i> Common Name	<i>Pinus Palustris</i> Longleaf Pine	<i>Quercus Alba</i> White Oak	<i>Castanea Dentata</i> American Chestnut
<i>Tensile Strength, psi</i>	Perpendicular to Grain	470	800	460
	Parallel to Grain	ND	ND	ND
<i>Compressive Strength, psi</i>	Perpendicular to Grain	960	1070	620
	Parallel to Grain	8470	7440	5320
<i>Shear Strength, psi</i>	Parallel to Grain	1510	2000	1080
<i>Flexural Strength, psi</i>	Modulus of Rupture	14500	15200	8600
<i>Modulus of Elasticity (E), ksi</i>	Longitudinal	1980	1780	1230
	Radial	202	290	ND
	Tangential	109	128	ND
<i>Shear Modulus (G), psi</i>	G _{LR}	141	153.08	ND
	G _{LT}	119	ND	ND
	G _{RT}	24	ND	ND
<i>Specific Gravity</i>	Oven-Dry	0.62	0.68	0.43
<i>Coefficient of Thermal Expansion, in/°F</i>	Longitudinal	See Note 2	See Note 2	See Note 2
	Radial	0.000017	0.000018	0.000013
	Tangential	0.000021	0.000022	0.000018
<i>Dimensional Change (from Green to Owendry MC)</i>	Radial	5.1	5.6	3.4
	Tangential	7.5	10.5	6.7
	Volumetric	11	16.4	11.6
Notes				
1 All Strength Values are at 12% MC				
2 Coefficient of Thermal Expansion parallel to the grain ranges from 1.7 to 2.5 X10 ⁻⁶ in/°F				
3 ND = No Data Available				

Table 2: Properties of Wood Species Found in Historic Structures in the United States (Source: Wood Handbook: Wood as an Engineering Material, 2010⁷⁰)

⁷⁰ Forest Products Laboratory (U.S.) and Benjamin Franklin Library Fund., *Wood handbook : Wood as an Engineering Material*.

Chapter 4 –Material Properties: Epoxy

In the United States, production of epoxies soared from 10 million tons in 1955 to more than 433 million tons in 1994.⁷¹ This boom highlights that epoxies have become highly useful in industry for their properties such as their “toughness, low shrinkage, high adhesion and good alkali resistance.” As such, epoxies are used today for surface coatings, adhesives, electronic component encapsulation, laminates and road surfacing. Of note, the adhesive industry use of epoxy comprises approximately 35% of the market production.⁷² Other industries that utilize epoxy resins include electrical and electronic, laminate and glass-fiber reinforced plastics, aerospace, and tool manufacturing. As discussed in Chapter Two, epoxy’s functionality as an adhesive makes it effective in repairs for wood. This chapter discusses the properties that allow epoxy to obtain high adhesion with wood.

Epoxies are compounds formed by the chemical reaction between a resin and curing or hardening agent which results in a polymer. The term polymer refers to a chemical structure of “a compound in which a large number of identical or similar atoms or groups of atoms are united by primary chemical bonds.”⁷³ Specifically, an epoxy must also contain a functional group called an *epoxide* (Figure 13) which is composed of a triangular structure of one oxygen atom and two carbon atoms. The two lines “projected from the two carbon atoms indicate bonds to other atoms in the molecule.”⁷⁴ As opposed to thermoplastic polymers which can be melted down, epoxies undergo a thermosetting reaction forming cross-linked polymers which cannot be either dissolved or melted. Due to this chemical-set or curing, epoxies exhibit little to no shrinkage unlike other polymerization processes.

⁷¹ Pham, "Epoxy Resins," 159.

⁷² Ping L. Ku, "Epoxy resins: Their manufacture and applications," *Advances in Polymer Technology* 8, no. 1 (1988): 88.

⁷³ Phillips and Selwyn, *Epoxies for Wood Repairs in Historic Buildings*: 3.

⁷⁴ *Ibid.*, 4.

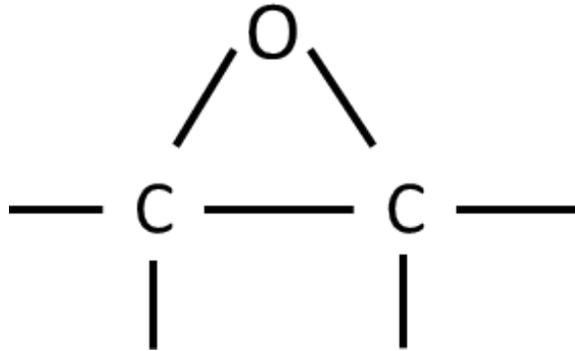

Figure 13: Epoxide Functional Group. As the epoxy cures the carbon atoms bond with nitrogen atoms in the amines (hardeners) which 'opens' up the epoxy ring. When the nitrogen atom bonds with the carbon atom it gives up a hydrogen atom which bonds with the oxygen. The number of hydrogen atoms that an amine has available to lose corresponds to the number of available sites for the epoxide to bond to. Thus amines with higher numbers of hydrogen atoms can achieve a greater degree of cross linked polymerization.

The mechanical, physical, and working properties of an epoxy can be varied by varying the number of polymer groups between epoxides. For example, a large number of polymer groups between epoxides yields a higher viscosity and a higher heat deflection temperature.

With regards to adhesive bonding in structural applications, there are several variables that affect the overall durability and overall performance of the epoxy bond. These variables can be grouped as properties that relate to the epoxy resin and the conditions during adhesive process including the required service conditions.⁷⁵ The first category of epoxy resin properties can be summarized as those that are internal to the actual resins which include both its physical, mechanical and working properties. Critical epoxy resin physical and working properties include the type, viscosity, molecular weight, hardener, pot life, cure time, fillers, and any solvent system if applicable. Mechanical properties include those such as the strength, shear modulus, swell-shrink resistance, and ultraviolet resistance of the cured epoxy. The other category of variables relates to the adhesive process. These factors are properties external to the epoxy

⁷⁵ Rowell, *Handbook of wood chemistry and wood composites*: 222.

resin such as adhesive amount, distribution, and environmental conditions such as relative humidity and temperature.

This chapter focuses on the properties that relate to the epoxy resin. The next chapter will consider the variables associated with adhesive process and required service conditions within the context of compatibility with historic wood conservation and repair.

Physical and Working Properties

Resin Type: Typically, the resin type is selected to suit a specific application. Liquid epoxy resin, or DGEBA (Diglycidyl Ether of Bisphenol A), is the type of resin used for wood conservation. Moreover, it is the base for which 75% of all other resins are derived.⁷⁶ DGEBA is product of the reaction of epichlorohydrin with bisphenol A. This basic resin can be modified further with diluents, fillers and other resins to vary its cured both cured and working properties.

Viscosity. Viscosity is the resistance to flow of the resin. Epoxies with low molecular weights have lower viscosity and thus flow more easily than those with higher viscosities. Viscosity's unit of measurement is the centipoise (Cps). For context, the viscosity of water is 1 Cps while peanut butter has a viscosity of 250,000 Cps.⁷⁷ Viscosity is an important property to consider as consolidation repairs require very low viscosities in order to penetrate the wood cells in contrast to gap-filling adhesives that require a high viscosity to maintain shape and form.

Hardener Type. Epoxy resins harden when they are reacting with a curing agent which enables crosslinking of the epoxy molecules. Amines are the most common curing agents used with epoxy resins. In this process the nitrogen of the amine group forms a bond with one of the carbons of the epoxy groups.⁷⁸

⁷⁶ Pham, "Epoxy Resins," 156.

⁷⁷ Mike Barnard, "Determining Epoxy's Physical Properties," *Epoxyworks* 2012, 1.

⁷⁸ Phillips and Selwyn, *Epoxies for Wood Repairs in Historic Buildings*: 6.

Pot Life. Pot life, or working life is the time interval between mixing resin and hardener and the gel formation of the material as it hardens. Specifically, West Systems defines pot life as “the amount of time you have to work with 100 grams of epoxy in a small container at room temperature (72 °F).”⁷⁹ This property is also defined by ASTM D1338. This property is dependent on the type of hardener used, size of container, volume of mixed and temperature.⁸⁰

Cure Time. The cure time of epoxy is generally accompanied by temperature and is the approximate time that it takes the epoxy to fully set and reach its maximum strength values.

Heat Deflection Temperature / Glass Transition Temperature. Both the heat deflection temperature (HDT) and the glass transition temperature are indications of the point at which the cured epoxy resin “changes from a glassy (solid) state to a soft, rubbery state.” When exposed to increasing temperature after hardening.⁸¹ The heat deflection temperature is determined through mechanical methods by means of flexure in accordance with ASTM D648. The glass transition temperature, represented by the symbol T_g , is a computerized measurement conducted in accordance with either ASTM E2602 (Digital Scanning Calorimetry), ASTM E1545 (Thermomechanical Analysis), and ASTM E1640 (Dynamic Mechanical Analysis). The heat deflection temperature and the glass transition temperature are related, so the value of one can easily be converted to the other. In practice, the determination of the HDT takes much longer than the determination of the glass transition temperature. For this reason, the glass transition temperature is reported for most products.

⁷⁹ Barnard, "Determining Epoxy's Physical Properties," 1.

⁸⁰ Ibid., 2.

⁸¹ Ibid., 3.

Mechanical Properties.

Unlike wood, properly mixed and cured epoxies are homogeneous and thus their mechanical properties are the same in all directions. However, these properties can vary significantly based on the resin composition, hardener and other modifications that manufacturers may make.

Tensile Strength. The tensile strength of epoxy is defined as its resistance to forces that act in one direction that tend to split or pull the epoxy apart. It is generally expressed as pounds per square inch (psi) and determined in accordance with ASTM D638 (Standard Test Method for Tensile Properties of Plastics).

Compressive Strength. The compressive strength is defined as its resistance to forces that act in one direction and tend to crush the epoxy. Like the tensile strength, the compressive strength is determined in accordance with ASTM D695 (Standard Test Method for Compressive Properties of Rigid Plastics).

Shear Strength. The shear strength is defined as wood's resistance against internal slippage along a plane parallel to the direction of loading. It is determined in accordance with ASTM D732 (Standard Test Method for Shear Strength of Plastics by Punch Tool).

Lap Shear Strength. The lap shear strength is a more specific service condition loading when bonding two substrates in a single lap joint. It is generally reported by the manufacturers as a measure of the strength of a joint and is typically determined in accordance with either ASTM D3163/3164 or ISO 4587.

Flexural Strength. The flexural strength defined as epoxy's resistance to bending loads and is also known as the modulus of rupture. It is determined in accordance with ASTM D-790

(Standard Test Methods for Flexural Properties of Unreinforced and Reinforced Plastics and Electrical Insulating Materials).

Modulus of Elasticity/Tensile Modulus. The modulus of elasticity (MOE), denoted by E in engineering equations, represents the tendency a material to deform under load. Epoxy manufacturers will also report this value as the tensile modulus. A high tensile modulus indicates the stiffness of the material. The MOE is determined from the tensile tests in accordance with ASTM D638 (Standard Test Method for Tensile Properties of Plastics).

Tensile Elongation. Tensile elongation is defined as the “change in length of a sample when loaded to failure.”⁸² A higher tensile elongation value indicates that the epoxy will ‘stretch’ more as it is deformed. Tensile elongation is expressed as a percentage and determined in accordance with ASTM D638 (Standard Test Method for Tensile Properties of Plastics).

Properties of Epoxy Products for Wood Repair.

There are numerous products on that are marketed for wood conservation and repair. Table 3 lists a range of products along with their intended use.

Epoxy Resin/Hardener	Structural	Type of Use
Araldite 1253	Maybe	Adhesive
Sikdatur 32 Hi-Mod	Yes	Adhesive
West 105/205	Maybe	Adhesive
Abatron LiquidWood	Yes	Consolidant
ConServ 100	No	Consolidant
PC-Rot Terminator	Yes	Consolidant
Smith System CPES	Yes	Consolidant
ART FLEX-TEC HV	Maybe	Filler
Abatron WoodEpoxy	Maybe	Filler
Triton Trimol 36	Yes	Filler
Rotafix Resiwood TG	Yes	Filler

Table 3: Epoxy Products for Wood Repair

⁸²Ibid., 2..

In order to demonstrate the variance in the range of properties, the following charts depict the reported properties from the epoxy products listed in Table 3.⁸³ These values will be used in the next chapter to assess compatibility by repair category. Of note from Figure 14 through Figure 18 is the significant variation in both working and mechanical properties. Moreover, not all manufacturers report the fundamental mechanical properties of their products. ConServ 100 is marketed to the wood conservation industry, but the product literature states that it is not intended for structural purposes, so it is logical that mechanical properties are omitted.

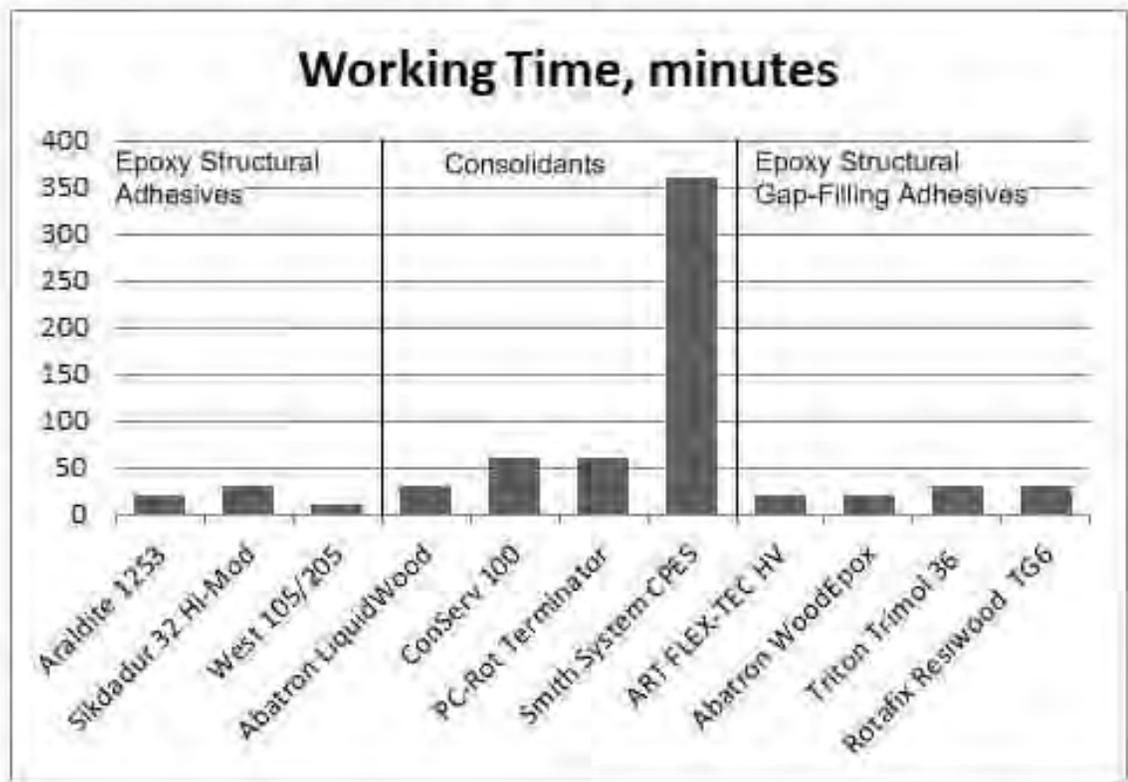

Figure 14: Working Times of Epoxy Wood Repair Products

⁸³ Product data sheets used to compile these charts have been consolidated in the Appendices.

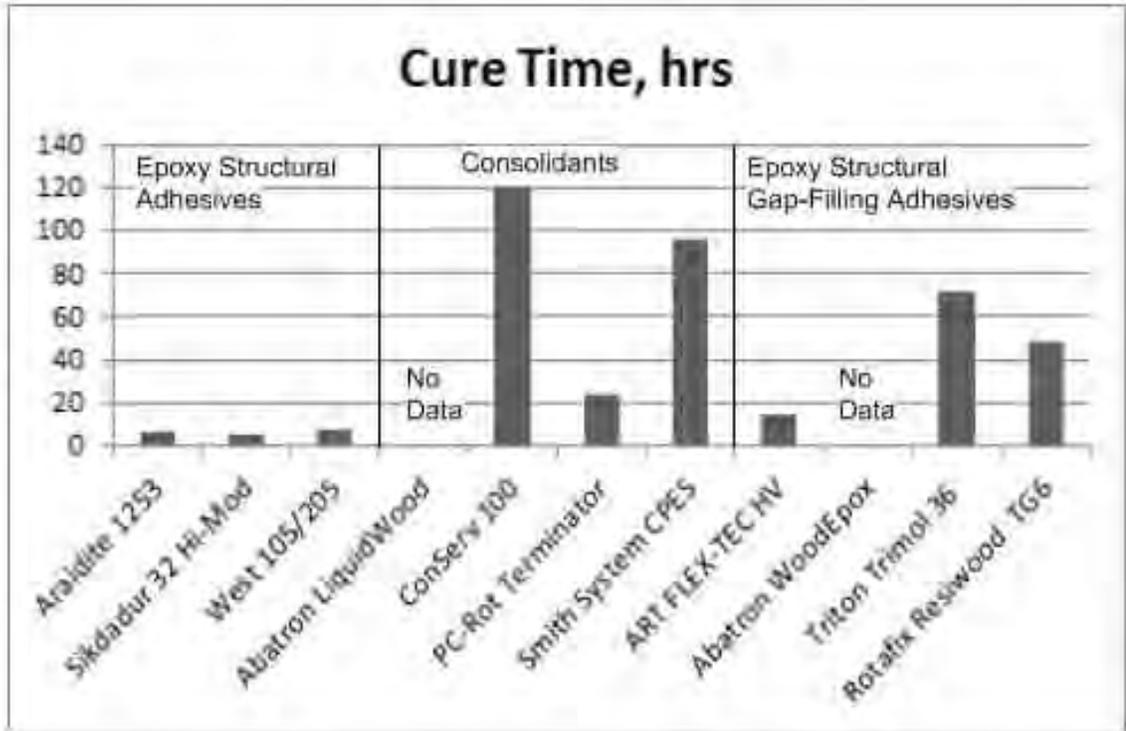

Figure 15: Cure Time of Epoxy Wood Repair Products

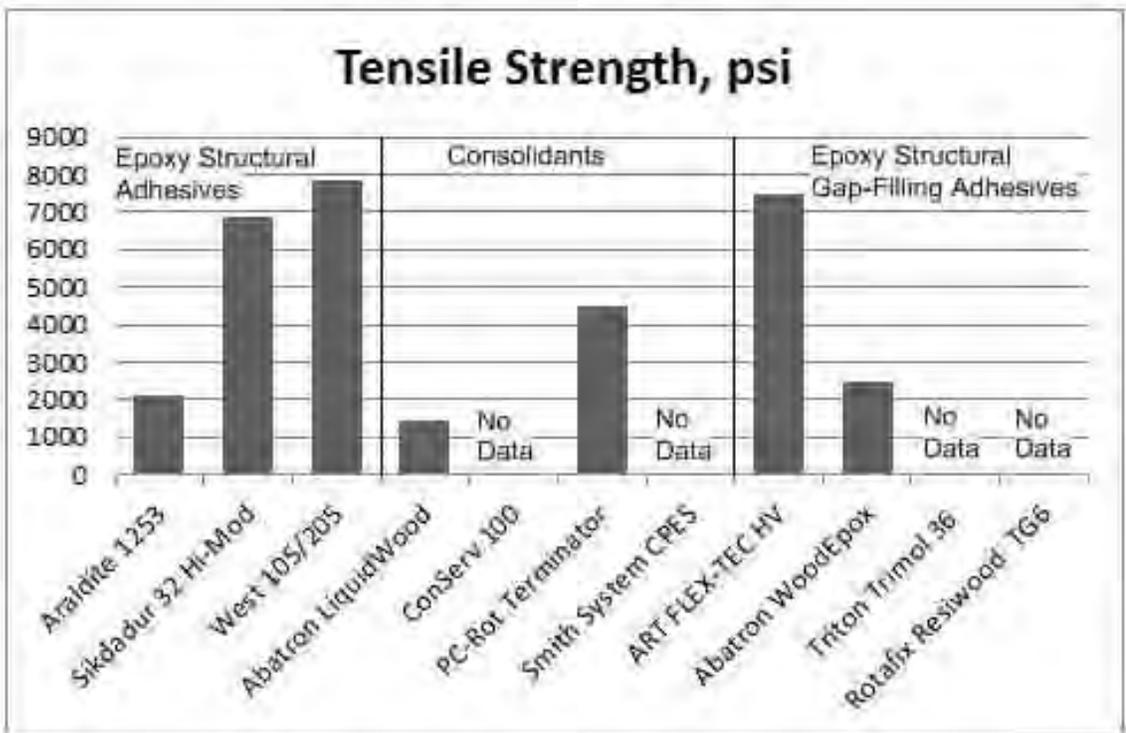

Figure 16: Tensile Strengths of Epoxy Wood Repair Products

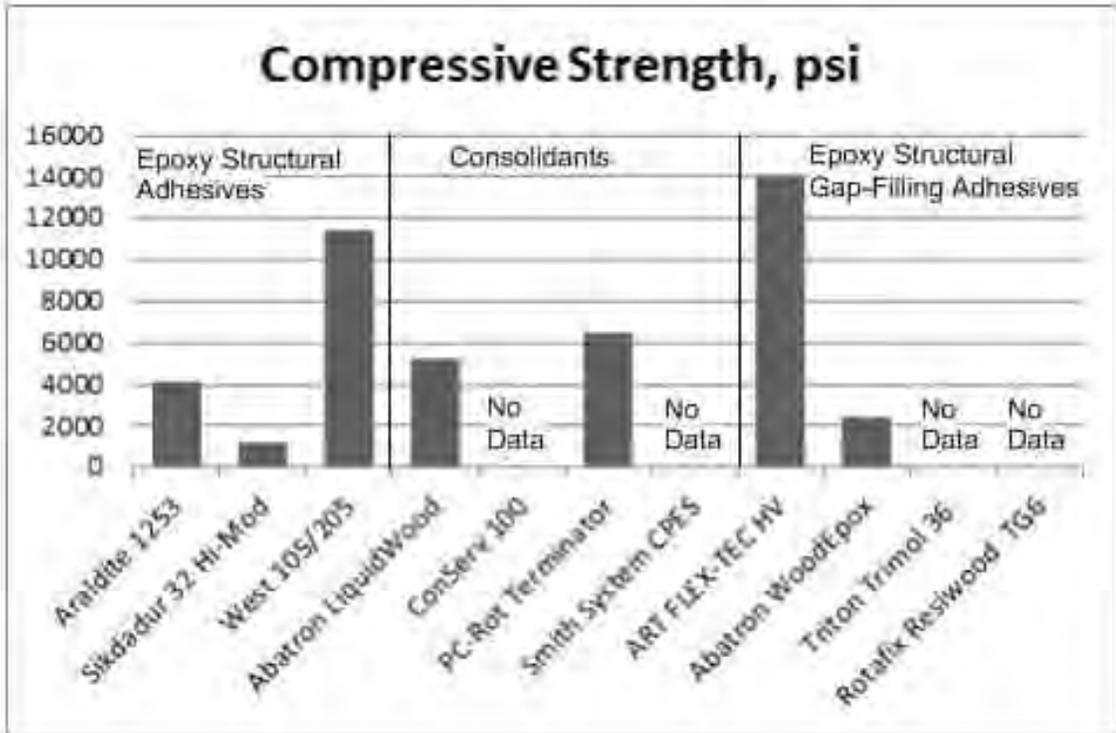

Figure 17: Compressive Strengths of Epoxy Wood Repair Products

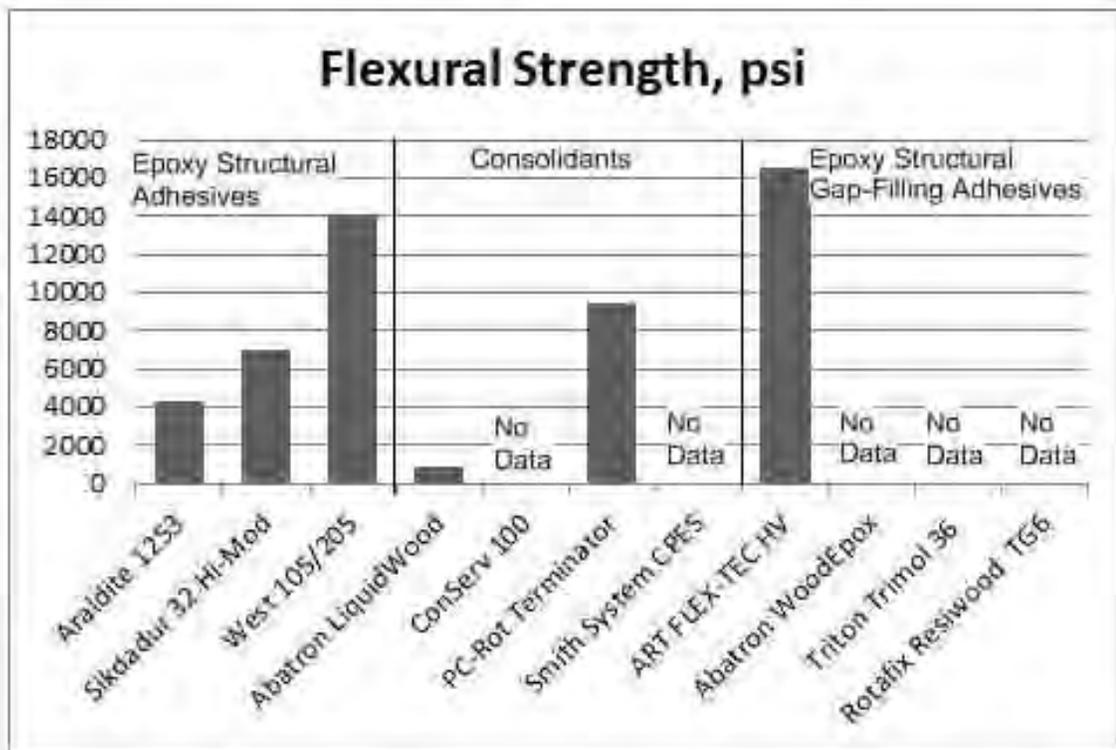

Figure 18: Flexural Strengths of Epoxy Wood Repair Products

Chapter 5 –Structural Compatibility of Wood and Epoxy

The compatibility of two materials is a measure of how well they perform together in an intended service application without any their dissimilarities having a negative effect on overall performance. Thus compatibility is essentially the probability of success between the marriage of two materials. The primary relationship of importance between epoxy and wood in all repairs of historic wood is the quality of the adhesive bond. The adhesive interface is where the structural compatibility of epoxy with wood must be assessed. However, assessing the performance of adhesively bonded wood assemblies requires an understanding of interrelation of the mechanical and chemical aspects of the bond strength. Furthermore, the compatibility of the two components of this adhesive relationship depends on variables such as the epoxy resin, the wood species, the adhesive process and the conditions and loads of service where and how the adhesive is employed. Table 4 lists the mechanical and chemical factors that affect each of the primary variables. Assessing compatibility epoxy and wood therefore requires isolating the dominant factors for a specific service application.

Previous chapters explored the variables related to the resin, wood and some service considerations. The following sections consider the compatibility of historic timber and epoxy when used as either a consolidant, adhesive, or gap-filling adhesive. This methodology allows for the assessment of this wood-epoxy relationship based on the volume of epoxy used and the intended service application. This methodology considers each category of epoxy repair in order in order to understand how the compatibility of the historic woods and epoxy affected by bulk material properties and environmental conditions based on the application.

Wood Bonding Variables			
Resin	Wood	Process	Service
Type	Species	Adhesive amount	Strength
Viscosity	Density	Adhesive distribution	Shear modulus
Molecular weight distribution	Mositure Content	Relative Humidity	Swell-shrink resistance
Mole Ratio of reactants	Plane of cut	Temperature	Creep
Cure rate	Heartwood vs. Sapwood	Open assembly time	Percentage of wood failure
Total Solids	Juvenile vs. mature Wood	Closed assembly time	Failure type
Catalyst	Earlywood vs. latewood	Pressure	Dry vs. wet
Mixing	Reaction Wood	Adhesive penetration	Modulus of Elasticity
Tack	Grain Angle	Gas-through	Temperature
Filler	Porosity	Press time	Hydrolysis resistance
Solvent System	Surface roughness	Pretreatments	Heat resistance
Age	Drying damage	Posttreatments	Biological resistance
pH	Machining damage	Adherend temperature	Finishing
Buffering	Dirt, contaminants		Ultraviolet resistance
	Extractives		
	pH		
	Buffering capacity		
	Chemical surface		

Table 4: List of variables that affect the bond performance of wood assemblies bonded with adhesives. Source: Handbook of Wood Chemistry and Wood Composites⁸⁴

Table 4 can be summarized with the following general equation⁸⁵:

Glued Product Performance

$$\begin{aligned}
 &= \text{Potential adhesion force} \pm \sum \text{Adhesive composition factors} \pm \sum \text{Wood property forces} \pm \sum \text{Wood preparation factors} \\
 &\pm \sum \text{Adhesive application factors} \pm \sum \text{Wood geometry factors} \pm \sum \text{Product service factors}
 \end{aligned}$$

Compatibility with Respect to Epoxy Consolidants

In the case of consolidation, the performance and compatibility of epoxy consolidant depends upon the extent of epoxy penetration within the wood structure.

This relationship can be quantified by the following equation⁸⁶:

$$Q = \frac{K \times A \times \rho \times g}{\mu} \times \left(\frac{\partial h}{\partial s} \right) \quad \text{(Equation 1)}$$

⁸⁴ Rowell, *Handbook of wood chemistry and wood composites*: 24.

⁸⁵ Custódio, Broughton, and Cruz, "A review of factors influencing the durability of structural bonded timber joints," 174.

⁸⁶ Schaffer, "Consolidation of Softwood Artifacts," 111.

Where Q is the volumetric flow of a fluid with a viscosity, μ , and density, ρ through a cross-section with an area, A , having a permeability of K under a gravitational acceleration, g with a hydraulic gradient pressure in the direction of the flow, $\left(\frac{\partial h}{\partial s}\right)$. Because the performance of consolidation repairs depends upon the ratio of the volume of epoxy that fills to the volume of the voids in the deteriorated and sound sections of wood, understanding the variables that maximize the ratio is critical.

As indicated by Equation 1, the permeability, or porosity, of the wood and the viscosity of the epoxy are critical parameters. Either an increase in wood porosity or a decrease in epoxy viscosity will increase the epoxy/void ratio in the repair. .

The porosity of the wood "is related to how internal cavities at the microscopic level communicate with each other."⁸⁷ Therefore, the primary determinant of compatibility depends on the micromorphology and anatomical features of the wood species and the .

Micro Morphology of Southern Pine, White Oak & American Chestnut

The anatomical features of wood structure vary widely between wood species. Softwoods are somewhat simple in structure and are comprised of only of longitudinal tracheids and rays. These structures enable the wood to transport water both longitudinally up the tree and transversely. Moreover, southern yellow pine also contains large resin canals. Hardwoods are more complex in their structure, comprised of vessels, tracheids and fibers. The vessels serve as the primary fluid transport conduit through the tree and vary in size with earlywood vessels being greater in size than latewood vessels. Although the tracheids and fibers allow for fluid transport, their cell walls are much thicker and thus limit such transport. Pitting occurs between vessels and tracheids and the pit apertures vary in both shape and size depending on

⁸⁷ Tomas Olsson et al., "Study of the transverse liquid flow paths in pine and spruce using scanning electron microscopy," *Journal of Wood Science* 47, no. 4 (2001): 282.

the wood species. These anatomical features transport fluid laterally between vessels and tracheids. However, both softwoods and hardwoods primary lateral fluid transport occurs through the rays which cross the tracheids, fibers and vessels. These sub-anatomical features also serve as the primary transport pathways for epoxy consolidants as well as adhesives. The depth of consolidation and penetration of any such consolidant is thus largely dependent upon these features.

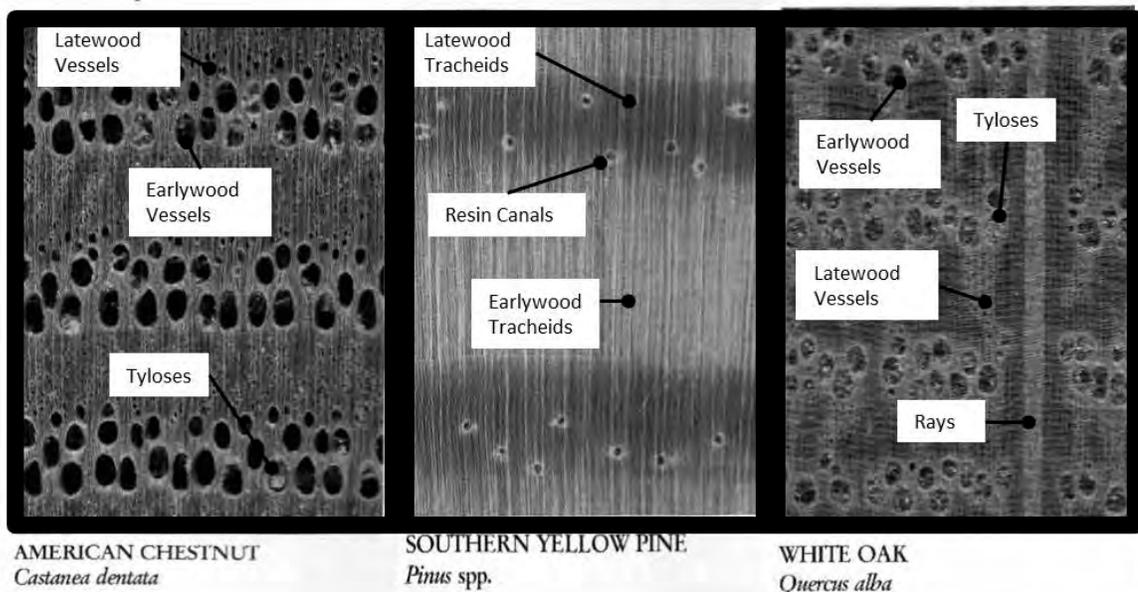

Figure 19: Cross section views of American Chestnut, Southern Yellow Pine and White Oak. The comparison shows the relative sizes of the vessels (chestnut/oak) and the tracheids and resin canals (southern pine). Source: Identifying Wood, Bruce Hoadley, 1998.⁸⁸

Figure 19 depicts cross-sectional views of each of the three historic woods and allows for quick visual comparison of the available cross-sectional area available for fluid and epoxy flow. Of note, both the American chestnut and the white oak have tyloses (or extractives present), the abundance in the white oak severely limits the flow of fluids and epoxy consolidants. Olsson et al examined the transverse liquid flow paths in pine with epoxy under the scanning electron microscope. They found the fluid retention in the ray tracheids in pine sapwood to

⁸⁸ R. Bruce Hoadley, *Identifying wood : accurate results with simple tools* (Newtown, CT: Taunton Press, 1998).

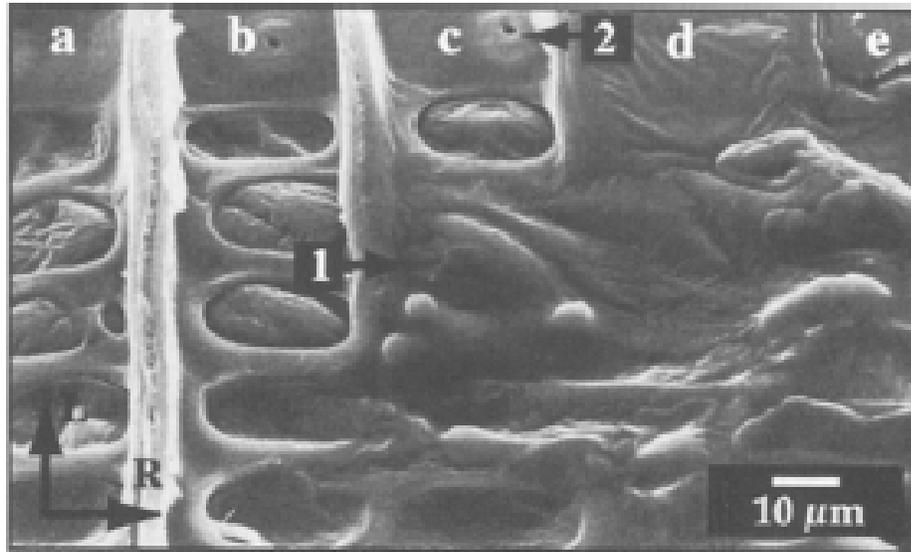

Figure 20: Longitudinal/radial plane in pine sapwood showing the effect of flow through distorted window pit membranes. The tracheids marked a and b are unfilled, whereas the tracheids marked c-e contain varying amounts of epoxy. The uppermost window pit membrane in tracheid c is intact, whereas the middle (1) and right pits apparently provide a path for the flow through distorted window pit membranes. The cross-field pit between ray tracheids and longitudinal tracheids are marked by 2; No evidence of transverse flow from ray tracheids is found in this micrograph. Source: Journal of Wood Science Volume 47, 2001.⁸⁹

be significantly greater than that found in pine heartwood as shown in Figure 21. "The main mechanism accounting for the reduced permeability of the pine heartwood is believed to be deposits of higher molecular weight substances (extractives) on the cell walls."⁹⁰ Although spruce is not a considered wood species in this thesis, Olsson's conclusion that thicker ray cells combined with smaller pits severely reduce the permeability of transverse flow is applicable. Thicker cell walls and a higher specific gravity are directly proportional, thus wood species with higher specific gravities generally have thicker cell walls. Therefore a comparison of the specific gravities of the historic wood species will indicate a very general assessment of their

⁸⁹ Olsson et al., "Study of the transverse liquid flow paths in pine and spruce using scanning electron microscopy," 285.

⁹⁰ Ibid., 288.

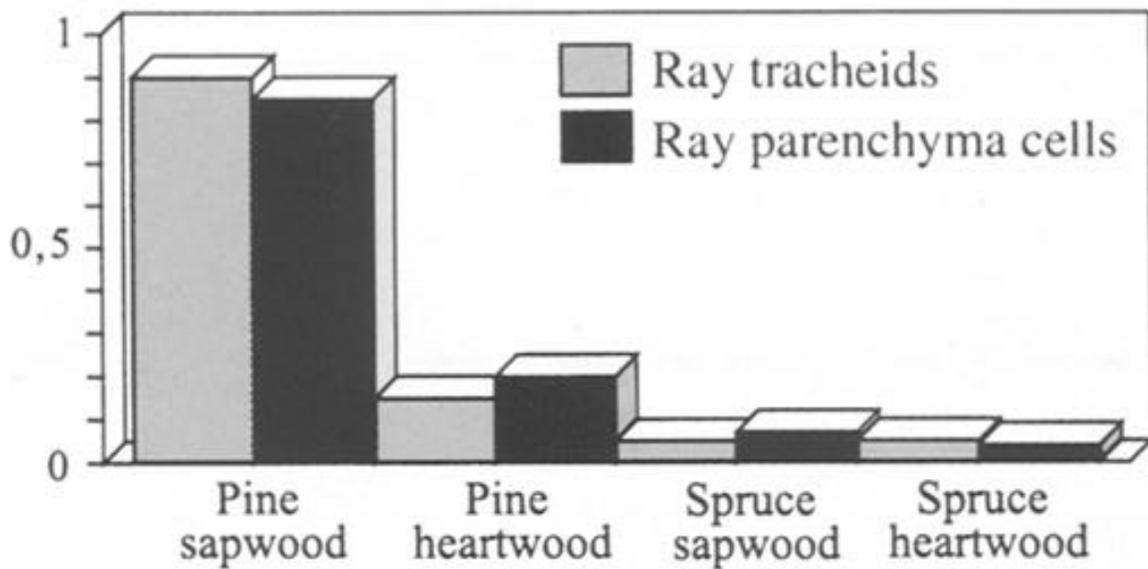

Figure 21: Fractional retention of epoxy in ray tracheids in both pine and spruce sapwood and heartwood. Source: : Journal of Wood Science Volume 47, 2001⁹¹

permeability and their compatibility with epoxy consolidants. In decreasing order of ease of consolidation is American chestnut with an specific gravity of 0.43, followed by southern yellow pine with a specific gravity range between 0.51 and 0.61 followed by white oak with a specific gravity of 0.68.

Factors Affecting Epoxy When Used as a Structural Adhesive

An epoxy bonded joint represents “a layer system comprising different materials and interfaces, all of which respond in different ways to an externally applied load and/or change in environmental conditions.”⁹² The adhesive bond system can be idealized as shown in Figure 22, which is comprised of eight layers: two wood layers; one adhesive layer; two adhesive interphase layers; two wood interphase layers; and two wood-adhesive interface layers.

⁹¹ Ibid., 284.

⁹² Custódio, Broughton, and Cruz, "A review of factors influencing the durability of structural bonded timber joints," 184.

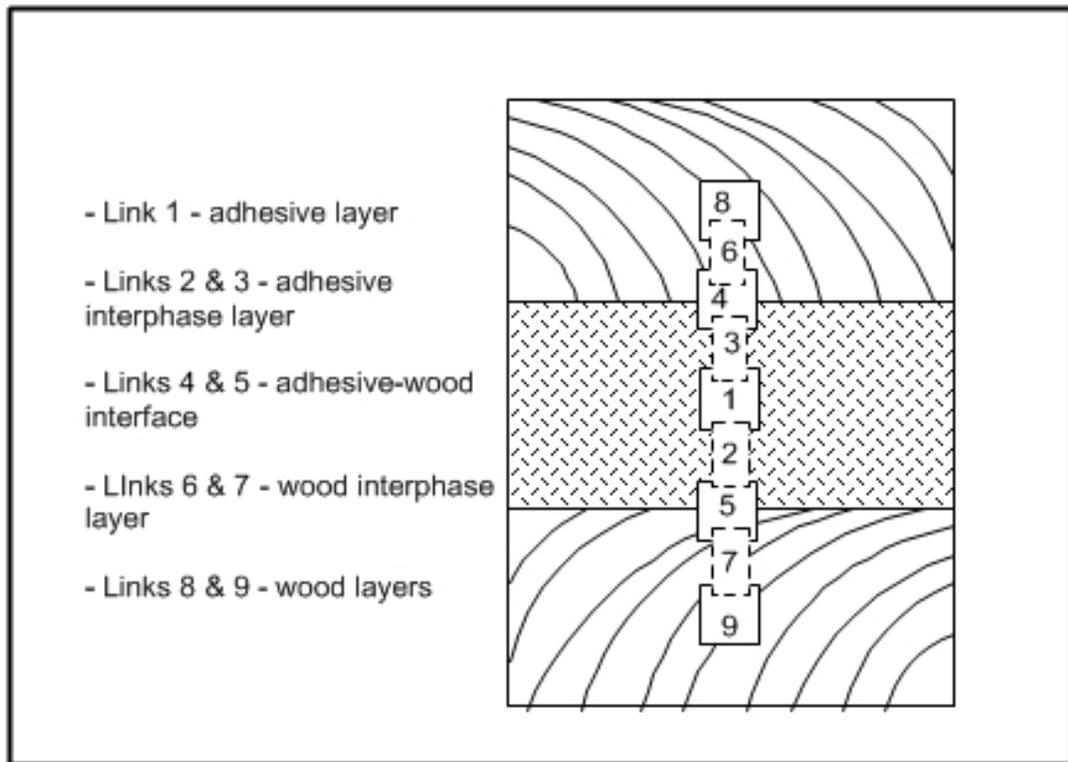

Figure 22: Idealized layers of a bonded wood joint in schematic form. Source: The Wood Handbook⁹³ (Figure redrawn and modified by Author for clarity)

The glueline thickness is the summation of the thicknesses from all the adhesive phase layers minus any wood portions. The current understanding of adhesion is based on the theory that “adhesion will occur between the adhesive and adherend because of physical forces established at the interface, as long as intimate contact is achieved.”⁹⁴ It is generally accepted that “mechanical interlocking and valence forces” are now the “main mechanisms by which bonds between adhesive polymers and molecular structures of wood are formed.”⁹⁵

⁹³ Forest Products Laboratory (U.S.) and Benjamin Franklin Library Fund., *Wood handbook : Wood as an Engineering Material*: 10-2.

⁹⁴ Custódio, Broughton, and Cruz, "A review of factors influencing the durability of structural bonded timber joints," 174.

⁹⁵ Ibid.

At the wood-adhesive phase layer, the variation in bulk and surface characteristics of different species of timber can significantly affect adhesion.⁹⁶ Specifically, these characteristics include: (1) wettability; (2) lack of contaminants/extractives; (3) surface roughness and porosity; (4) surface soundness; (5) surface uniformity; (6) adhesive compatibility; and (7) stability in the operating environment.⁹⁷ Because mechanical interlocking is essential to the wood-epoxy bond penetration of the epoxy into the wood interphase layer is important and is affected by the same factors discussed for epoxy-wood compatibility in consolidation.

In addition to the wood surface factors, the process and product service conditions must be taken into account. Of critical importance “in the design of a structurally bonded connection is the moisture content of the members.”⁹⁸ The primary concern with moisture deals with “the movement [dimensional change] in the timber resulting from this change in moisture content [that] will induce stresses in the glue line.”⁹⁹ Another critical factor in bond performance is temperature. Temperature produces several comorbid negative effects. First, because wood is hygroscopic, its equilibrium moisture content is dependent on both temperature and relative humidity. In service, the structural wood member may see varying temperatures and relative humidity conditions. As the temperature and relative humidity rise, the amount of moisture the wood cells absorb from the air will increase and they will swell. In regards to application of epoxy, applying epoxy at a service temperature and relative humidity will result in less penetration as there will be less void space due to the swelling of the wood fibers. Conversely, apply it at a low temperature and relative humidity will induce significant compressive stresses on the epoxy as the wood swells as the temperature and relative humidity rise throughout the

⁹⁶ Broughton, "Adhesive systems for structural connections in timber," 180.

⁹⁷ G. Davis, "The performance of adhesive systems for structural timbers," *International Journal of Adhesion and Adhesives* 17, no. 3 (1997): 249.

⁹⁸ *Ibid.*, 253.

⁹⁹ *Ibid.*, 251.

year. Service temperature also directly affects structural performance; tests conducted by Cruz and Custódio found that “temperature may well limit the performance and durability of bonded structural joints if adhesives with low glass transition temperatures are used” and that even temperatures not higher than 45°C had effects that “may be critical for structural safety.”¹⁰⁰ The ultimate consideration is how these variables affect the penetration of the epoxy adhesive into the wood at the wood-adhesive interphase layer. A greater depth of penetration yields a stronger mechanical interlock between the two materials. The general effects of these factors as well as cure rate of the epoxy and bond pressure are depicted in Figure 23.

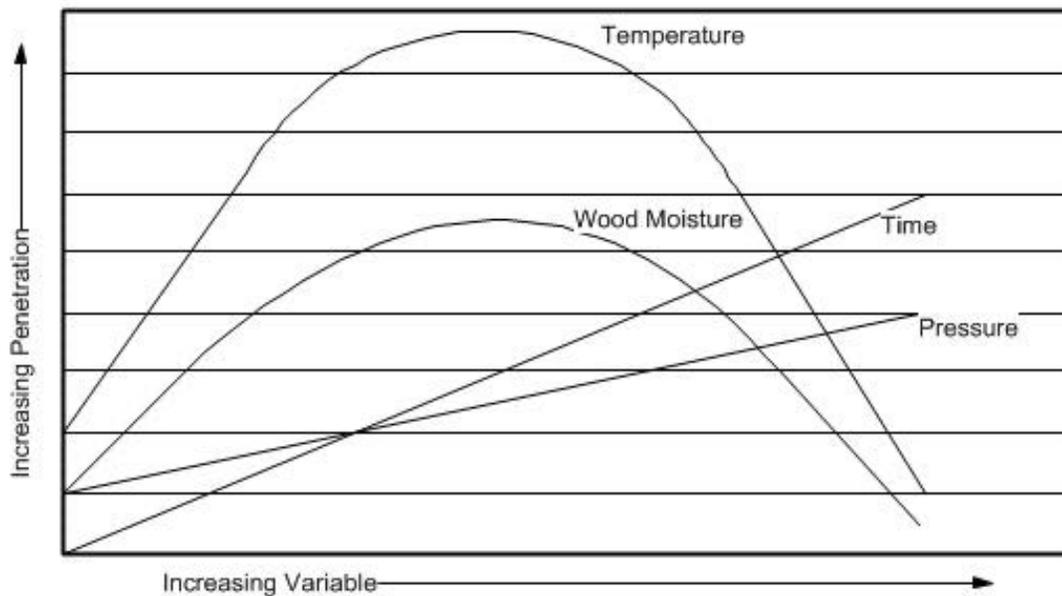

Figure 23: General effect of conditions on adhesive penetration. Increasing temperature makes the adhesive more fluid until too much causes polymerization. At low wood moisture content the epoxy is able to easily fill the wood cell voids, while at high wood moisture content, water retards the penetration because the wood fibers swell and eventually free water in the voids prevents epoxy penetration. Both an increase in bond pressure and a longer [cure] time promote adhesive penetration. Source: Handbook of Wood Chemistry and Wood Composites¹⁰¹ (Figure re-drawn and modified by Author for clarity)

¹⁰⁰ Helena; Custodio Cruz, Joao, "Thermal performance of epoxy adhesives in timber structural repair" (paper presented at the 9th World Conference on Timber Engineering, Portland, OR, USA, 2006).

¹⁰¹ Rowell, *Handbook of wood chemistry and wood composites*: 239.

Wheeler and Hutchinson examined epoxy resin-bonded timber with the respect to various species and moisture contents and concluded that “epoxy resins were able to bond timber of up to 22% moisture content without any significant depreciation in bond strength or change in locus of failure.”¹⁰²

The grain angle of the epoxy-bonded wood has a significant impact on the joint performance. Avent (1986) examined the effect of grain angle on epoxy by testing samples of southern pine in a double shear test. In order to assess the effect of the grain angle on the bond strength, the center piece was always loaded parallel to the fibers; however, the angle of the member was varied.

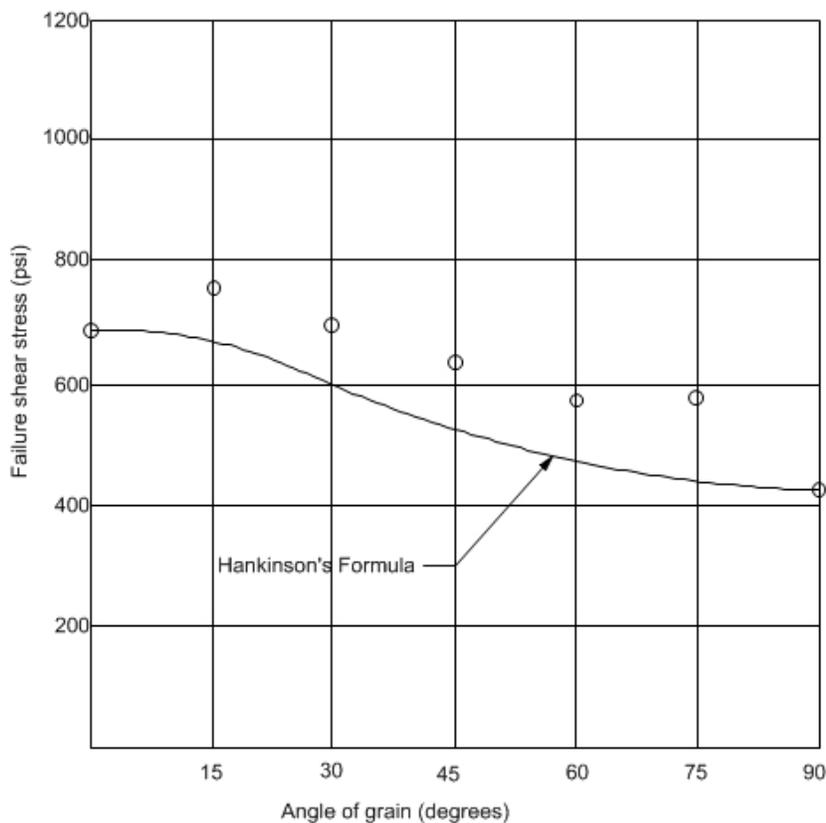

¹⁰² Wheeler and Hutchinson, "Resin repairs to timber structures," 12-13.

Figure 24: Effect of grain orientation on failure shear stress for No. 2 Southern Pine double shear joints (circles indicate average value for each test series). Source: Journal of Structural Engineering 112, Issue 2, 1986. (Figure redrawn by Author for clarity).¹⁰³

Avent discovered that the effect of grain angle on bond strength could be approximated using Hankinson's formula.¹⁰⁴

$$N = \frac{P \times Q}{P \times \sin^2 \theta + Q \times \cos^2 \theta} \quad (\text{Equation 2})$$

Where N is the shear strength at angle θ , and P is the shear strength of the member parallel to the grain and Q is the shear strength of the member perpendicular to the grain. Figure 24 depicts the results of his testing along with the line predicted by Hankinson's formula. Based on these tests, an increase in the grain angle yields a decrease in bond shear strength.

Structural Adhesive Bonds with Respect to Historic Timber

Independent of epoxy adhesives, the wood species will affect the ability to achieve an adhesive bond. Recent testing of structurally bonded wood has focused primarily on White Oak. Specifically, the research is in agreement that acidic extractives that leach out of over time will negatively affect bond performance.¹⁰⁵ However, because the performance of the bond is primarily a factor of mechanical interlocking at the adhesive-wood interphase layer, the surface characteristics discussed as part of the compatibility for historic wood and consolidation also apply to epoxy bonds with historic timber. Of note, the Wood Handbook classifies American chestnut as a species that bonds easily, southern pine as a species that bonds well and white oak as a species that bonds satisfactorily.¹⁰⁶ 'Bonds easily' means indicates the species bonds easily with adhesives of a wide range of properties and a wide range of bonding conditions.

Bonding well indicates that the species bonds well with a fairly wide range of adhesives under a

¹⁰³ Avent, "Factors Affecting Strength of Epoxy-Repaired Timber," 219.

¹⁰⁴ Ibid., 218.

¹⁰⁵ Broughton, "Adhesive systems for structural connections in timber," 180.

¹⁰⁶ Forest Products Laboratory (U.S.) and Benjamin Franklin Library Fund., *Wood handbook : Wood as an Engineering Material*: 10-7.

moderately wide range of bonding conditions. A satisfactory bond indicates that the wood species will bond well with good-quality adhesives under well controlled bonding conditions.

Factors affecting Epoxy When Used as a Structural Gap-Filling Adhesive

Gap-filling epoxies must not only be able to form a good bond with the wood, but must also

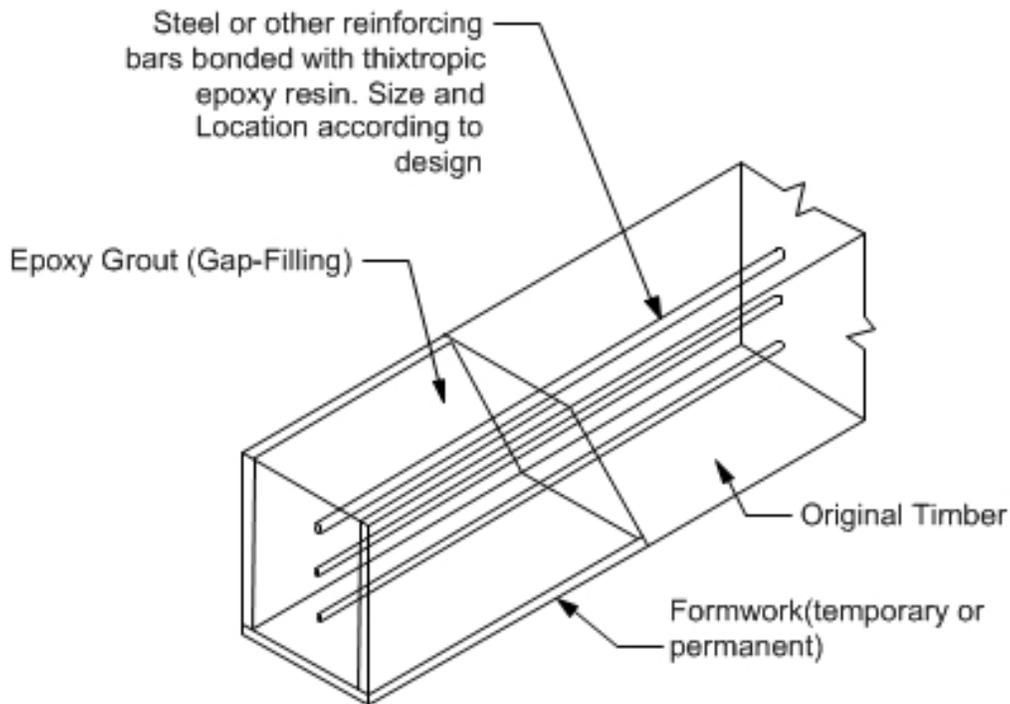

Figure 25: Typical beam-end repair with reinforcing bars inserted in holes drilled into end grain and bonded with epoxy resin. Epoxy grout replaces removed timber. Source: Internatinal Journal of Adhesion and Adhesives Volume 17 Number 3¹⁰⁷ (Figure redrawn by Author for clarity)

must have a high viscosity to maintain shape during curing and sufficient mechanical strength to serve as a replacement for the wood that has been removed. Because the structural load must be transferred from the sound wood to the epoxy, typically some sort of embedded reinforcement is present to provide surface area for load transfer other than at the wood/epoxy interface. "This requires the adhesive to bond to different substrates together, each of which

¹⁰⁷ Davis, "The performance of adhesive systems for structural timbers," 253.

has considerably different strength properties and other characteristics.”¹⁰⁸ Such a repair is depicted by Figure 25, and are characterized by large volumes of epoxy; in these applications, the epoxies are commonly referred to as epoxy grouts, presumably because of the inclusion of aggregates to reduce epoxy volume and exothermic curing temperatures.¹⁰⁹ The addition of reinforcement, in the form of plates or rods, relieves the epoxy from having to form a perfect adhesive bond at the wood interface, because the load transfer can also occur through the reinforcement. Research and testing by Stumes concluded in cases where the wood member had lost its structural strength “the entire load can be transferred to the epoxy and reinforcement.”¹¹⁰

Similar to epoxy adhesives applications, wood moisture content and service temperature can both negatively affect the performance of the epoxy-wood repair. Testing by Stumes indicated that “the great structural strength of epoxy quickly diminishes above normal room temperature” further noting that such temperatures can easily occur “in the vicinity of heating conduits, high wattage lighting fixtures or under an acute exposure to the sun.”¹¹¹ More recently, testing by Hutchinson and Broughton has focused on the effect of wood moisture content on the bonded-in reinforcement rods, finding timber specimens, and more specifically white oak, exhibited reduced pull-out strengths, regardless of epoxy or rod type used at higher moisture contents.¹¹² Specimens above 30% moisture content, corresponding to saturated wood, exhibited significantly reduced pull-out strength in the order of 60-65%.¹¹³ They also found that as the moisture content increased the locus and mode of failure “relocated from

¹⁰⁸ Ibid., 252.

¹⁰⁹ Broughton, "Adhesive systems for structural connections in timber," 178.

¹¹⁰ Stumes, "Testing the Efficiency of Wood Epoxy Reinforcement Systems."

¹¹¹ Ibid., 34.

¹¹² J.G.; Hutchinson Broughton, A.R, "Effect of timber moisture content on bonded-in rods," *Construction and Building Materials* 15(2001): 24.

¹¹³ Ibid.

within a thin layer of the adhesive close to the rod/adhesive interface, to that of a mixed timber/adhesion failure or an apparent failure at the adhesive/timber interface.”¹¹⁴ Their findings indicate several points related to the performance of gap-filling epoxy adhesives. First, when in a dry service state, the bond between the epoxy and the reinforcement dominates performance; second, as the wood becomes saturated, the bond between the wood and the epoxy begins to dominate the performance.

With regard to service temperature, Custódio et al. “that the commercial epoxy adhesives displayed significantly different viscoelastic responses over the temperature range attained during normal service” and therefore “temperature-induced creep is a risk factor that needs to be considered cautiously.”¹¹⁵ This is especially significant for gap filling epoxy adhesives where they not only perform as an adhesive but also as a structural prosthetic.

Summary of Factors Affecting Epoxy –Wood Structural Compatibility

Structural epoxy-bonded connections with historic timber are affected by numerous factors. The compatibility between wood and epoxy begins with an understanding of the adhesive relationship, which occurs primarily through mechanical interlock from the penetration of the epoxy fluid into the wood’s cell structure. By examining the current state of knowledge with respect to epoxy applied as a consolidant, adhesive and gap-filling adhesive, the critical factors influencing the performance and ultimately the compatibility of the two materials is better understood. With regards to consolidation, the viscosity of the epoxy as well as the surface morphology and anatomical structure of the individual wood species determines the performance. When used as an adhesive, the critical factors include the surface properties and

¹¹⁴ Ibid.

¹¹⁵ João Custódio, James Broughton, and Helena Cruz, "Rehabilitation of timber structures – Preparation and environmental service condition effects on the bulk performance of epoxy adhesives," *Construction and Building Materials* 25, no. 8 (2011): 3581.

anatomical structure of the wood species but both moisture content and service temperature become critical factors. And when used in bulk as a gap-filling adhesive, service temperature and wood moisture content dominate the performance of the repair.

Chapter 6 –Conclusions & Recommendations

This thesis has focused on examining the current state of knowledge of epoxy repairs for historic structural timber. The woods species were limited to American Chestnut, White Oak, and Southern Pine because they were determined to be dominant in historic timber construction. Epoxy was examined with respect to its compatibility with these timber species in structural repair applications. Epoxy, for the purposes of structural repair, serves as a substitution type repair for deteriorated wood. Thus, this thesis has endeavored to answer the question of compatibility between these two materials, one organic and the other plastic. Compatibility, as defined in this thesis, is an indication of how well the two materials perform together in an intended service application without allowing their dissimilarities to negatively affect overall performance. In his building pathology textbook, Samuel Y. Harris succinctly defined the problem with compatibility of substitution repairs in the following passage,

‘The disadvantage of substitution is that the rate and deterioration mechanism of the replacement material is something of a gamble. Despite best efforts to predict performance, the peculiarities of the substitution condition are idiosyncratically specific, meaning that the substitute material brings with it a level of uncertainty as to performance.’¹¹⁶

Therefore, this thesis sought to identify the peculiarities that both encourage and hinder the compatibility of wood and epoxy in repairs to historic structural timber. In order to accomplish this assessment, epoxy repairs have been categorized as consolidation, structural adhesive or gap-filling adhesive. The intent was to assess the compatibility of the two materials with respect to ratio of the volume of epoxy to the volume of wood void with consolidation with the lowest ratio and gap-filling adhesive with highest ratio.

¹¹⁶ Harris, *Building Pathology : Deterioration, Diagnostics, and Intervention*: 43.

At its most fundamental level, the governing relationship between epoxy and wood is that of an adhesive. This relationship is complicated because an “understanding how an adhesive works is difficult since adhesive performance is not one science of its own, but the combination of many sciences.”¹¹⁷ Furthermore, the interface between the wood substrate and the epoxy is best modeled as a system of layers. The theories across the sciences for describing adhesive performance focus on some combination of mechanical and chemical aspects of bonding. This thesis ascertained that within the framework of the current state of knowledge, mechanical interlock is the primary bonding mechanism.¹¹⁸ This framework thus refined the paradigm through which the compatibility between wood and epoxy would be assessed. At the global level compatibility would be assessed based on repair type followed by an examination at the micro or molecular level focused on the ability to obtain adequate mechanical interlocking. Finally, the external effects of the environment, including temperature and moisture, were examined to determine their effects on the compatibility.

Conclusions

Assessment of Structural Compatibility with Regards to Epoxy Use as a Consolidant

With respect to consolidation, the porosity of the wood and viscosity of the epoxy dominate performance. Wood species porosity is determined by the macro and micro features of the wood cell structure. However, because all wood cells have the same density, the porosity of a species can be derived from its specific gravity. Thus wood samples with lower specific gravities have more voids and therefore greater porosity. Figure 26 illustrates the relative compatibility of the three historic wood species based on specific gravity.

¹¹⁷ Rowell, *Handbook of wood chemistry and wood composites*: 220.

¹¹⁸ Custódio, Broughton, and Cruz, "A review of factors influencing the durability of structural bonded timber joints," 174.

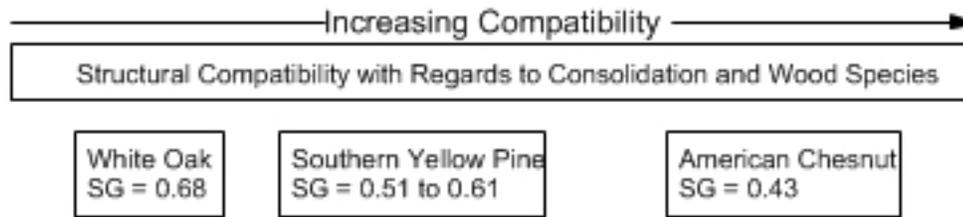

Figure 26: Structural compatibility with regards to consolidation and wood species

There are other micro anatomical wood cell features that may cause a variance in the porosity of a specific species such as the presence of extractives and features such as the shape and size the pitting between vessels and tracheid which allow transverse fluid flow. However, specific gravity is still the best measure of porosity. The research shows that epoxy viscosities in the range of 500-700 centipoises are adequate to allow the resin to penetrate the cell structure and achieve satisfactory consolidation. In addition to viscosity, the working and curing times of an epoxy must also be taken into account. Longer working and curing times result in greater penetration as the epoxy is able to flow deeper into the cell structure before it begins to polymerize. Of the products reviewed in this thesis, the ones marketed as consolidants had the greatest working and curing times which is consistent with this conclusion. Furthermore, depth of penetration and thus performance is enhanced by application through the end grain which maximizes penetration through maximizing the exposure to the largest voids and natural uptake direction of the wood cells.

Although a low viscosity epoxy and porous wood are compatible structurally, their durability is negatively affected by consolidation. As the decayed and surrounding sound wood is consolidated, the voids in the wood cells are filled. Thus a member that once allowed the free transport of water and water vapor throughout its structure becomes plugged, creating a moisture dam at the limit of epoxy consolidation. Because rot fungi require moisture, the creation of such a dam will eventually encourage rot at the interface of the consolidated wood and the sound wood. Because as higher moisture contents negatively affect the mechanical properties of the wood, this damming effect of the consolidation will actually lead to localized areas of decreased structural capacity. Even though structural compatibility, or the ability for epoxy to penetrate the wood's cell structure, is possible; the overall durability, or long-term performance, is actually decreased as new rot takes hold at the interface. Because of the lack of reversibility of the previous treatment which now serves to plug one end of the structural timber element, future treatments will have to be more invasive and destructive to the fabric. As a final note, the durability of consolidated wood would actually be the inverse of the structural compatibility with regards to specific gravity. Because high specific gravities result a lesser degree of consolidation, they would then maintain some a greater degree of porosity in comparison to woods with lower specific gravities. Accordingly, as the structural compatibility is increased based on wood species the long term durability is decreased.

Assessment of Compatibility with Regards to Epoxy Use as a Structural Adhesive

ASTM D 907-12a: Standard Terminology for Adhesives defines a "structural adhesive as a bonding agent used for transferring required loads between adherends exposed to service

environments typical for the structure involved.”¹¹⁹ As the unit volume of epoxy to wood increases a shift from the surface and mechanical of properties of the wood to the bulk properties of the epoxy and environmental service conditions occurs. Whereas in consolidation the wood cell structure of a species in combination with the epoxy viscosity determined the degree of consolidation, the bond performance when epoxy is used as a structural adhesive depends primarily upon the preparation of the wood surface, wood grain angle orientation, wood moisture content and service temperature. Although other factors such as pressure during epoxy application and cure time affect the performance, the primary detriment to epoxy bond performance is water exposure. In studies “examining bondline failure for epoxy adhesives from both ASTM 2559 [Standard Specification for Adhesives for Bonded Structural Wood Products for Use Under Exterior Exposure Conditions] and D 905 (wet) [Standard Test Method for Strength Properties of Adhesive Bonds in Shear by Compression Loading], failure was often in the epoxy interphase layer.”¹²⁰ Due to wood’s hygroscopic nature, it absorbs more water than the epoxy, and the resultant hygroscopic dimensional change in wood at the interface can cause stresses at the rigid epoxy bondline which eventually exceed the strength of the epoxy.¹²¹ The structural compatibility is negatively affected by the rigid cross-linked structure of the epoxy bondline which is unable to distribute the stress throughout the adhesive. Thus in humid and wet environments the application of epoxy as a structural adhesive can exhibit poor structural compatibility with wood.

However, at moisture contents less than 22%, moisture does have any detrimental effects on the bond strength. Under these dry service conditions the surface preparation, grain

¹¹⁹ ASTM International., D907 Standard Terminology of Adhesives, (West Conshohocken, PA: American Society for Testing and Materials ,, 2012). 9.

¹²⁰ Frihart Charles R, "Are Epoxy-Wood Bonds Durable Enough?" (paper presented at the Wood adhesives 2005, Holiday Inn on the Bay, San Diego, California, 2006 2005), 242.

¹²¹ Ibid., 243.

orientation and service temperature are the critical factors and determinants of bond performance and durability. Because wood adhesive bonds are dependent on the mechanical interlocking of the epoxy into the cell structure, the surface preparation is critical to establishing a bond. Like consolidation, the macro and micro cell structure features determine the depth of penetration and consequently the degree of mechanical interlock. Wood bonded at an angle greater than parallel exhibited a decrease in bond strength that could be approximated with Hankinson's formula. However, it is the dissimilarities between wood and epoxy with response to service temperatures that leads to their structural incompatibility. Recent testing by Cruz and Custódio found that "temperature may well limit the performance and durability of bonded structural if adhesives with glass transition temperatures are used" with effects that "may be critical for structural safety" in service temperatures not higher than 113°F. The mechanical properties of wood increase as it dries under increasing temperatures and thus the wood become more rigid while the epoxy tends to plasticize, or become more flexible, as glass transition temperature is approached. Therefore, it may be concluded that when used as a structural adhesive, epoxy exhibits poor structural compatibility even in dry conditions when service temperatures approach glass transition temperature.

Assessment of Compatibility with Regards to Epoxy Use Structural Gap-Filling Adhesive

When used as a structural gap filling adhesive, the epoxy is paired with reinforcement in order to transfer the structural load from sound wood to the epoxy filler. The reinforcement is embedded in the epoxy filler as well as the sound wood. Additionally if the epoxy replaces an embedded beam end, the epoxy shear strength must be taken into account as a load bearing element. The epoxy also serves as the adherent between the embedded reinforcement and wood, each with different bulk properties. Thus the adhesive relationship is further complicated

by the addition of a third structural material. In this form of substitution, a significant portion of wood is removed and substituted with the epoxy adhesive. As such, epoxy's bulk property, the glass transition temperature, becomes the critical limitation in this type of repair.

In the same respect as structural adhesives, the replacement of timber with epoxy is negatively affected by both humid or wet service conditions as well as high service temperature. Hutchinson and Broughton has focused on the effect moisture content on the bonded-in reinforcement rods, finding timber specimens, and more specifically white oak, exhibited reduced pull-out strengths, regardless of epoxy or rod type used at higher moisture contents.¹²² With regard to wet or humid service conditions, Hutchinson and Broughton tested on the effect moisture content on the bonded-in reinforcement rods, finding timber specimens, and more specifically white oak, exhibited reduced pull-out strengths, regardless of epoxy or rod type used at higher moisture contents.¹²³ Even more significant was the finding that at wood moisture contents above 30% the pull-out strength was reduced by up to 65% and the failure of the epoxy bond moved from the rod/epoxy interface to the wood/epoxy interface. Additionally, absorption of water moisture due to high levels of humidity can decrease the glass transition temperature of the epoxy. Also in terms of initial epoxy curing, testing found that "the higher the percentage of relative humidity of exposure, the lower the residual heat of reaction."¹²⁴ This means that higher levels of humidity at time of application can actually retard the cure and prevent complete polymerization yielding lower than expected strength. In regards to temperature, testing by Custódio et al., found that the significantly different viscoelastic properties of commercial epoxies combined with the expected temperature range during

¹²² Broughton, "Effect of timber moisture content on bonded-in rods," 24.

¹²³ Ibid.

¹²⁴ M; Frigione Lettieri, M., "Effects of humid environment on thermal and mechanical properties of a cold-curing structural epoxy adhesive," *Construction and Building Materials* 30(2012).

normal service made temperature-induced creep a critical risk factor.¹²⁵ For the large scale replacement of whole timber sections, including beam ends, this potential of slow and permanent deformation poses structural safety issues.

Summary of Conclusions regarding Compatibility with Respect to Epoxy Application

<u>Application</u>	<u>Service Condition</u>	<u>Critical Wood Properties</u>	<u>Critical Epoxy Properties</u>	<u>Structural Compatibility</u>	<u>Durability / Long Term Performance</u>	<u>Structural Compatibility /Durability Concern</u>
Consolidation	Dry (MC <10%)	Wood Cell Structure, Specific Gravity	Viscosity, Cure Time	Good	Good	No concerns as long as keep dry
Consolidation	Wet/Humid	Wood Cell Structure, Specific Gravity	Viscosity, Cure Time	Good	Poor	Impermeable moisture dam at limit of consolidation
Structural Adhesive	Dry (MC <10%)	Wood Cell Structure, Surface Properties, Grain Orientation, Moisture Content	Glass Transition Temperature , Shear Strength	Poor	Poor	Reduced Bond performance/strength based on normal service temperature range
Structural Adhesive	Wet/Humid	Wood Cell Structure, Surface Properties, Grain Orientation, Moisture Content	Glass Transition Temperature , Shear Strength	Poor	Poor	Incomplete cure of epoxy / Rigid epoxy not able to distribute stresses due to swelling of wood
Structural Gap-Filling Adhesive	Dry (MC <10%)	Wood Cell Structure, Surface Properties, Moisture Content	Glass Transition Temperature , Shear Strength,	Poor	Poor	Reduced Bond performance/strength based on normal service temperature range
Structural Gap-Filling Adhesive	Wet/Humid	Wood Cell Structure, Surface Properties, Moisture Content	Glass Transition Temperature , Shear Strength, Compressive Strength	Poor	Poor	Reduced bond performance with embedded reinforcement / Decreased glass transition temperature

Table 5: Summary of Structural Compatibility and Durability Assessment with regards to Epoxy Based Repairs for Wood and Service Condition

Table 5 summarizes the assessment of the structural compatibility and durability in line with the current state of the art of knowledge regarding epoxy wood repairs. The table illustrates that as

¹²⁵ Custódio, Broughton, and Cruz, "Rehabilitation of timber structures – Preparation and environmental service condition effects on the bulk performance of epoxy adhesives," 3581.

the ratio of epoxy volume to wood void volume is increased there is a shift from wood adhesion factors such as surface preparation and wood cell structure to the bulk properties of the epoxy. This is significant in the case of structural gap filling epoxies, where the epoxy becomes a separate structural element. In all cases, epoxies with low glass transition temperatures, as is the case with the current commercial epoxy products on the market, cause both significant structural compatibility and durability concerns. Because epoxy repairs are marketed to consolidate, repair or replace rotted and deteriorated sections of wood, they are typically being used in locations of high moisture content. Furthermore, the compounding effects of both moisture and temperature compound the compatibility concerns as both negatively affect the bulk properties of epoxy. In order to increase the bulk properties of the epoxy, the molecular weight and consequently the size of the cross-linked polymer chains increase. Thus epoxies with higher glass transition temperatures would be less capable of penetrating the wood cell structure and creating a satisfactory mechanical bond. Therefore, based on the current research and marketed products epoxy repairs are not recommended for wood repairs, especially where structural loading requirements exist.

Only in the case of consolidation with epoxy in a dry environment, was a positive conclusion supported, as long as there is no chance of the wood getting wet. This would only be applicable to the consolidation of wooden artifacts in environmentally controlled environments, such as museums. However, in these cases there is no requirement for structural strength to support additional loading. Research in this field has been carried out successfully by conservators; however, there has not been sufficient research to recommend the use of epoxy consolidants in cases where structural requirements were present.

Finally, the compatibility of the historic wood species with consolidants and adhesive products is summarized in Table 6. American chestnut as a species bonds easily; southern pine

as a species that bonds well and white oak as a species bonds satisfactorily.¹²⁶ 'Bonds easily' means indicates the species bonds easily with adhesives of a wide range of properties and a wide range of bonding conditions. Bonding well indicates that the species bonds well with a fairly wide range of adhesives under a moderately wide range of bonding conditions. And a satisfactory bond indicates that the wood species will bond well with good-quality adhesives under well controlled bonding conditions. These observations are tied to the wood species'

<i>Application</i>	<i>Historic Wood Species Compatibility</i>
<i>Consolidation</i>	American Chestnut - Best Southern Yellow Pine = Satisfactory White Oak = Poor
<i>Structural Adhesive</i>	American Chestnut - Bonds Easily Southern Yellow Pine = Bonds Well White Oak = Bonds Satisfactorily
<i>Structural Gap-Filling Adhesive</i>	American Chestnut - Bonds Easily Southern Yellow Pine = Bonds Well White Oak = Bonds Satisfactorily

Table 6: Summary of Historic Wood Species Bonding Compatibility.

cellular anatomy and they take into account other factors such as the presence and abundance of extractives. For example, in addition to the abundance of tyloses that block the vessels in white oak, it also contains acidic extractives that leach out of over time negatively affecting bond performance.¹²⁷ The best predictor of compatibility with either consolidants or adhesives used with wood species is the species specific gravity as it is an indicator of porosity. The conclusions regarding bonding compatibility are exclusive of the epoxy applications. Although these historic wood species exhibit bonding potential, the dissimilarities in how both wood and epoxy react to the environmental factors of moisture and temperature are cause not to recommend epoxy as a valid repair method for historic structural wood elements.

¹²⁶ Forest Products Laboratory (U.S.) and Benjamin Franklin Library Fund., *Wood handbook : Wood as an Engineering Material*: 10-7.

¹²⁷Broughton, "Adhesive systems for structural connections in timber," 180.

BIBLIOGRAPHY

- ASTM International. *D907 Standard Terminology of Adhesives*. West Conshohocken, PA: American Society for Testing and Materials, 2012.
- Avent, R. "Design Criteria for Epoxy Repair of Timber Structures." *Journal of Structural Engineering* 112, no. 2 (1986/02/01 1986): 222-40.
- . "Factors Affecting Strength of Epoxy-Repaired Timber." *Journal of Structural Engineering* 112, no. 2 (1986/02/01 1986): 207-21.
- Barnard, Mike. "Determining Epoxy's Physical Properties." *Epoxyworks*, 2012.
- Broughton, J., Hutchinson, A. "Adhesive Systems for Structural Connections in Timber." *International Journal of Adhesion & Adhesives* 21 (2001): 177-86.
- Broughton, J.G.; Hutchinson, A.R. "Effect of Timber Moisture Content on Bonded-in Rods." *Construction and Building Materials* 15 (2001): 17-25.
- "Bureau Beta: Restoration Techniques in the Plastic Age." *Netherlands American Trade*, 1977, 7-13.
- Cruz, Helena; Custodio, Joao. "Thermal Performance of Epoxy Adhesives in Timber Structural Repair." Paper presented at the 9th World Conference on Timber Engineering, Portland, OR, USA, 2006.
- Custódio, João, James Broughton, and Helena Cruz. "Rehabilitation of Timber Structures – Preparation and Environmental Service Condition Effects on the Bulk Performance of Epoxy Adhesives." *Construction and Building Materials* 25, no. 8 (2011): 3570-82.
- . "A Review of Factors Influencing the Durability of Structural Bonded Timber Joints." *International Journal of Adhesion and Adhesives* 29, no. 2 (2009): 173-85.
- Davis, G. "The Performance of Adhesive Systems for Structural Timbers." *International Journal of Adhesion and Adhesives* 17, no. 3 (1997): 247-55.
- Faherty, Keith F., Thomas G. Williamson, and Harry E. Humphreys Book Fund. *Wood Engineering and Construction Handbook*. 3rd ed. 1 vols New York: McGraw-Hill, 1997.
- Forest Products Laboratory (U.S.), and Benjamin Franklin Library Fund. *Wood Handbook : Wood as an Engineering Material*. General Technical Report. 1 vols Madison, WI: Forest Products Laboratory ; Madison Washington, D.C. : Supt. of Documents, U.S. GPO, 2010.
- Gougeon, Meade. *The Gougeon Brothers on Boat Construction: Wood and West System Materials*. 5th ed. Bay City, Michigan: Gougeon Brothers, Inc., 2005.
- Graham, Tony. "Resin Bonded Timber Repair and the Preservation of Historic Timber Surfaces." University of Bath, 2004.
- Grattan, D. W., and R. L. Barclay. "A Study of Gap-Fillers for Wooden Objects." *Studies in Conservation* 33, no. 2 (1988): 71-86.
- Harris, Samuel Y. *Building Pathology : Deterioration, Diagnostics, and Intervention*. New York: J. Wiley, 2001.
- "History: West System Epoxy." West System, <http://www.westsystem.com/ss/history/>.
- Hoadley, R. Bruce. *Identifying Wood : Accurate Results with Simple Tools*. Newtown, CT: Taunton Press, 1998.
- . *Identifying Wood : Accurate Results with Simple Tools*. Newtown, CT: Taunton Press, 1990.
- Hoffmann, Per, and A. Jones Mark. "Structure and Degradation Process for Waterlogged Archaeological Wood." Chap. 2 In *Archaeological Wood*. Advances in Chemistry, 35-65: American Chemical Society, 1989.
- ICOMOS. "The Nara Document on Authenticity." Nara, 1994.

- Klapwijk, Dick. "Bureau Beta, Restoration Techniques in the Plastic Age." *Netherlands American Trade*, no. November (1977): 7-13.
- . "Method of Restoring a Wooden Beam." In *United States Patent*, 4. United States: Bouweconomisch en Technologisch Adviesbureau B.V., 1975.
- Ku, Ping L. "Epoxy Resins: Their Manufacture and Applications." *Advances in Polymer Technology* 8, no. 1 (1988): 81-91.
- Larson, Knut. "A Note on the Authenticity of Historic Timber Buildings with Particular Reference to Japan." In *World Heritage Convention: ICOMOS*, 1992.
- Lavisci, P., S. Berti, B. Pizzo, P. Triboulot, and R. Zanuttini. "A Shear Test for Structural Adhesives Used in the Consolidation of Old Timber." [In English]. *Holz als Roh- und Werkstoff* 59, no. 1-2 (2001/04/01 2001): 145-52.
- Lettieri, M; Frigione, M. "Effects of Humid Environment on Thermal and Mechanical Properties of a Cold-Curing Structural Epoxy Adhesive." *Construction and Building Materials* 30 (2012): 753-60.
- Munnikendam, R. A. "Low Molecular Weight Epoxy Resins for the Consolidation of Decayed Wooden Objects." *Studies in Conservation* 17, no. 4 (1972): 202-04.
- Nilsson, Thomas, and Roger Rowell. "Historical Wood – Structure and Properties." *Journal of Cultural Heritage* 13, no. 3, Supplement (2012): S5-S9.
- Olsson, Tomas, Modris Megnis, Janis Varna, and Henrik Lindberg. "Study of the Transverse Liquid Flow Paths in Pine and Spruce Using Scanning Electron Microscopy." [In English]. *Journal of Wood Science* 47, no. 4 (2001/08/01 2001): 282-88.
- Pham, H.Q; Marks, M.J. "Epoxy Resins." In *Ullmann's Encyclopedia of Industrial Chemistry*. Freeport, TX: Dow Chemical, 2012.
- Phillips, Morgan W., and Judith E. Selwyn. *Epoxies for Wood Repairs in Historic Buildings*. Washington: Office of Archeology and Historic Preservation, Heritage Conservation and Recreation Service, U.S. Dept. of the Interior, Technical Preservation Services Division : for sale by the Supt. of Docs., U.S. Govt. Print. Off., 1978.
- R, Frihart Charles. "Are Epoxy-Wood Bonds Durable Enough?" Paper presented at the Wood adhesives 2005, Holiday Inn on the Bay, San Diego, California, 2006 2005.
- Richard Avent, R. "Decay, Weathering and Epoxy Repair of Timber." *Journal of Structural Engineering* 111, no. 2 (1985/02/01 1985): 328-42.
- Rowell, Roger M. *Handbook of Wood Chemistry and Wood Composites*. Boca Raton, Fla.: CRC Press, 2005.
- Sadd, Martin H., and Daniel R. Curran. "Mode I Fracture Toughness of Epoxy Impregnated Wood." *Mechanics Research Communications* 9, no. 5 (1982): 331-36.
- Schaffer, E. "Consolidation of Softwood Artifacts." *Studies in Conservation* 16, no. 3 (1971): 110-13.
- Sites, International Council on Monuments and. "Principles for the Preservation of Historic Timber Structures." Paper presented at the 12th General Assembly, Mexico, 1999.
- Stumes, Paul. "The Application of Epoxy Resins for the Restoration of Historic Structures." *Bulletin of the Association for Preservation Technology* 3, no. 1 (1971): 59-63.
- . "Testing the Efficiency of Wood Epoxy Reinforcement Systems." *Bulletin of the Association for Preservation Technology* 7, no. 3 (1975): 2-35.
- Stumes, Paul, and Association for Preservation Technology. *W.E.R. -- System Manual : Structural Rehabilitation of Deteriorated Timber*. Ottawa: Association for Preservation Technology, 1979.

- Szabo, T. "Plywood Reinforcement for Structural Wood Members with Internal Defects." *Bulletin of the Association for Preservation Technology* 9, no. 1 (1977): 11-15.
- Van Gemert, D.;Vanden Bosch, M. "Structural Restoration of Wooden Beams by Means of Epoxy Resin." *Materials and Structures* 20 (1987): 165-70.
- Wang, Y., and A. P. Schniewind. "Consolidation of Deteriorated Wood with Soluble Resins." *Journal of the American Institute for Conservation* 24, no. 2 (1985): 77-91.
- Wheeler, A. S., and A. R. Hutchinson. "Resin Repairs to Timber Structures." *International Journal of Adhesion and Adhesives* 18, no. 1 (1998): 1-13.
- Zuener, Diana. "Daft Idea." *Weald & Downland Open Air Museum* 2003, 34-37.

Appendix A: Abatron LiquidWood & WoodEpoxy Technical Specifications



ISO 9001/2008 Registered

Restore Rotted Wood in Three Easy Steps

1 Prepare Wood

Remove old paint, dirt, and debris. Clean oily surfaces with detergent, water, or solvents.

2 Apply LiquidWood



To strengthen the wood, apply LiquidWood with a brush, or pour directly on the surface. LiquidWood penetrates and hardens.

3 Apply WoodEpoxy



To rebuild missing pieces of wood and fill cracks and holes, apply WoodEpoxy. When hard, it can be sanded, stained, painted, and nailed.



LiquidWood® and WoodEpoxy®

Wood Restoration System

The Standard to Restore and Replace Wood

LiquidWood® Reinforces, rebuilds and waterproofs wood by hardening after penetrating. Regenerates rotted window-sills, frames, structural and decorative parts, furniture, columns, boats, floors. Primer for WoodEpoxy.

WoodEpoxy® Structural adhesive putty. Most versatile, high-strength, no-shrink adhesive paste to fill, repair and replace wood and other materials in structures, walls floors, furniture, sculptures. A standard in workshops, plants, buildings, museums, shipyards and homes.

Specified by U.S Government agencies, state and national restoration centers, museums, architects and other professionals, LiquidWood and WoodEpoxy represent the greatest advance in wood restoration history. They give new life to rotted, severely damaged wood, and are the only hope for parts that cannot be replaced because of size, shape or artistic reasons. Restored pieces are fully functional and often stronger and more durable than the original. Repairs are permanent.

LiquidWood®

Deep penetrating wood consolidant that regenerates and waterproofs rotted, dried-out, or spongy wood. Restores structural strength and durability to wood fibers. With LiquidWood, a piece of deteriorated wood that could crumble under finger pressure can be impregnated and restored to a rigid, durable, water and weather resistant wood superior to the original. The hardened mass can be sawed, planed, routed, carved, drilled, nailed, sanded, glued, and painted. LiquidWood is also a primer for WoodEpoxy.

Uses: LiquidWood is ideal for regenerating and waterproofing rotted, dried-out or spongy window sills, thresholds, window and door frames, columns, stair steps, balustrades, floors, capitals, moldings, doors, shutters, indoor and outdoor furniture, archaeological and art restoration, boats, and millwork of all kinds.

Features & Benefits: LiquidWood has exceptional adhesion, structural strength, versatility, permanence, dimensional stability, and water resistance. LiquidWood A and B are easy to use, are 100% reactive compounds, and contain no VOC's or noxious odors.

Technical Characteristics: Contents: LiquidWood consists of 2 clear, epoxy liquids: resin (A) and hardener (B). When A and B are mixed together in equal volumes, by simple stirring, a blend is formed with unique properties to impregnate and restore wood and other porous masses. Application: pour or brush on the wood where it penetrates the fibers and hardens into a water-resistant, distortion-free, high-strength mass in hours or minutes. 100% solids. 1/1 ratio. 30 minute pot life.

		Kg/cm ²	Mpa	Psi
Tensile Strength		103	10.1	1460
Compressive Strength		366	36	5210
Flexural Strength		63	6.2	900
Hardness Shore D	42			
Elongation	84%			

"I purchased your wood restoration kit this summer and used LiquidWood and WoodEpoxy in order to repair damaged windowsills that I thought were beyond repair. I had rotted, wet, spongy windows in multiple spots throughout my home. I was absolutely amazed at how well your wood restoration kit worked, and I'm especially astonished by the properties of WoodEpoxy."

*P.S., Homeowner
Fayetteville, North Carolina*



WoodEpoxy[®]

Shrink-free adhesive putty **wood replacement compound** that can be used in any thickness in structural and decorative applications to replace, repair, extend, or fill wood and other materials.

Uses: WoodEpoxy is ideal for repairing, replacing, or adding to wood and most rigid surfaces, as well as to dried out, rotted or spongy wood consolidated with LiquidWood. Use on windowsills, thresholds, window and door frames, columns, stair steps, balustrades, floors, capitals, moldings, doors, shutters, indoor and outdoor furniture, statues, archaeological and art restoration.

Features & Benefits: WoodEpoxy bonds permanently with high strength to most surfaces. It fills cracks, holes, and voids of any size without the shrinking and crumbling of common wood fillers. It can replace or add missing or new sections in window frames and sills, furniture, sculptures, structural and decorative components, indoors and outdoors. Because of its strength and durability, it is a truly permanent solution where alternatives would surely fail.

WoodEpoxy succeeds because it can be painted, stained, wood-grained, sawed, nailed, planed, sanded, carved, and machined like wood. Can be cast into shapes and sculpted by hand before hardening. It can also be carved after hardening. Bonds equally well to ceramics, concrete, metal, glass, fiberglass, and most rigid surfaces. Contains no VOC's or noxious odors. It has a light, neutral color that can be changed, while mixing with stains, dyes, or pigments. Has a no slump paste consistency that allows it to be applied like a putty to fill gaps, holes, or to build-up virtually any thickness and shape.

Technical Characteristics: Contents: WoodEpoxy is a light-weight epoxy adhesive system consisting of 2 components: resin paste (A) and hardener paste (B). When A and B are mixed in equal volumes, the blend hardens within 1-2 hours into a light-weight, non-shrinking, tough adhesive mass with high dimensional stability, chemical, water, heat and weather resistance. 100% solids. 1/1 ratio. 20 minute pot life.

		Kg/cm ²	Mpa	Psi
Tensile Strength		176	17.5	2500
Compressive Strength		389.8	37.92	2300-2800
Hardness Shore D	53-55			
Elongation	4%			



LiquidWood and WoodEpoxy are ideal for log home repair and restoration



Related Products

Abosoly™: Solvent for LiquidWood. Use for thinning LiquidWood and cleaning up.

Abocure 7912-1™: Cold weather hardener for use with LiquidWood (A) that can be applied in sub-freezing weather with excellent results. When combined with LiquidWood (A), Abocure 7912-1 permits LiquidWood to harden overnight, even in subfreezing weather conditions. Recommended for exterior use only.

Abocure 8512-1™: Paste-like cold weather hardener for use with WoodEpox (A). It can be applied in sub-freezing weather with excellent results. When combined with WoodEpox (A), Abocure 8512-1 permits WoodEpox to harden without an external heat source. Recommended for exterior use only.

Pigments: A variety of pigments that can be blended into WoodEpox while mixing uniformly to match wood tones. One or more can be blended to create depth of color and varying tones. Pigments include (from left to right): Dark Brown, Brick Red, Dark Yellow and Black.



Clearstrip™: Environmentally friendly paint remover designed to remove multiple layers in one action. Will not mar normal wood patina. It is biodegradable, nonflammable and very low odor. Contains no caustic or methylene chloride. Can be used on most varieties of paints and varnishes.

For a complete description of ABATRON's products and accessories related to wood restoration visit the company's website below or call for a free catalog.

Follow These Simple Instructions:

- 

1. Apply to clean and dry surface after removing contaminants, oil, grease, wax, old paint and debris.
- 

2. Mix a volume of LiquidWood A with an equal volume of LiquidWood B for at least one minute with blade or paddle.
- 

3. Apply LiquidWood mix to deteriorated wood by brushing, pouring or injecting.
- 

4. For deeper penetration into wood, drill small holes through side grain and across end grain, and pour LiquidWood into holes. Repeat process until wood is saturated.
- 

5. Mix thoroughly a volume of WoodEpox A with an equal volume of WoodEpox B.
- 

6. Apply WoodEpox to wood primed with LiquidWood while LiquidWood is still "tacky" to fill cracks, holes and replace missing wood.
- 

7. Sand, plane, shape, paint and stain restored wood as desired.



5501 95th Ave.
Kenosha, WI 53144
800-445-1754
www.abatron.com
info@abatron.com



© 11/2020 ABATRON CORP.

Appendix B: Araldite 1253 Technical Specifications

Advanced Materials**Araldite® AV 1253 Resin
Hardener HV 1253 Adhesive****CARVABLE EPOXY PASTE FOR WOOD****DESCRIPTION :**

Araldite® AV 1253 resin/hardener HV 1253 epoxy adhesive is a carvable paste especially suited for bonding and repairing wood. Mahogany in color, it is easy to saw, carve, drill, tap and work with woodworking tools. The two-component epoxy system is color coded to facilitate thorough mixing and has easy-to-use, one-to-one (by volume) mixing ratio. Although it is recommended for repairing and bonding wood products, the epoxy system can also be used to bond metals and other substrates.

TYPICAL PROPERTIES :

<u>Property</u>	<u>Test Method</u>	<u>Test Values⁽¹⁾</u>	
		<u>Resin</u>	<u>Hardener</u>
Color/Form	Visual	Brown Paste	Light Purple Paste
Specific Gravity	ASTM D-792	0.82	0.64
Resistance @ 77 °F (25 °C)		Pass 1 in. (2.5cm)	Pass 0.5 in. (1.25cm)
		Fail 1.25 in. (3.2 cm)	Fail 0.75 in. (1.92 cm)

TYPICAL MIXED PROPERTIES :

<u>Property</u>	<u>Test Method</u>	<u>Test Values⁽¹⁾</u>
Resin/Hardener Ratio (by weight)	ASTM D-2471	100/82
Resin/Hardener Ratio (by volume)		100/100
Pot Life @ 77 °F (25 °C)		20 min.
Sag Resistance @ 77 °F (25 °C)		Pass 0.5 in. (1.25 cm)
		Fail 1 in. (2.5 cm)

CURE SCHEDULE :

<u>Temperature</u>	<u>Cure Time</u>
77 °F (25 °C)	6 hours
140 °F (60 °C)	30 minutes
212 °F (100 °C)	10 minutes
302 °F (150 °C)	10 minutes

TYPICAL CURE PROPERTIES :

Lap shear strength Effect of Time and Temperature

<u>Cure Temperature</u>	<u>Exposure Time</u>	<u>Shear Strength</u>	
		<u>psi</u>	<u>MPa</u>
77 °F (25 °C)	4 hours	1560	11
	8 hours	1990	14
	24 hours	2280	16
140 °F (60 °C)	10 min	1560	11
	20 min	1990	14
	30 min	1990	14
212 °F (100 °C)	5 min	1710	12
	10 min	1850	13
	20 min	1850	13
	30 min	1990	14
302 °F (150 °C)	5 min	1710	12
	10 min	1850	13
	20 min	1850	13
	30 min	1850	13

TYPICAL CURE PROPERTIES :

Effect of Temperature

Load applied 10 minutes after joint test temperature – cured 20 min at 212 °F (100 °C)

<u>Cure Temperature</u>	<u>psi</u>	<u>Shear Strength</u>	
		<u>MPa</u>	
-76 °F (-60 °C)	1710	12	
77 °F (25 °C)	1990	14	
176 °F (80 °C)	140	1	

Properties of Araldite® AV 1253 resin / Hardener HV 1253 adhesive

Cured 7 days @ 77 °F (25 °C)

Deflection Temperature, °F (°C) (ASTM D-648) @ 66 psi 124 (51)

<u>Property</u>	<u>Test Method</u>	<u>psi</u>	<u>MPa</u>
Compressive Properties	(ASTM D-695) @ 77 °F (25 °C)		
Strength – ultimate		4120	29
Strength – 0.02 % offset		2840	20
Modulus of elasticity		161000	1130
Tensile Properties	(ASTM D-638) @ 77 °F (25 °C)		
Strength – ultimate		2130	15
Strength – 0.02 % offset		1850	13
Modulus of elasticity		140000	985
Flexural Properties	(ASTM D-790) @ 77 °F (25 °C)		
Strength – ultimate		4270	30
Modulus of elasticity		149000	1050

Tested @ 77 °F (25 °C), unless otherwise noted.

CAUTION :

Huntsman Advances Materials Americas Inc. maintains up-to-date Material Safety Data Sheet (MSDS) on all of its products. These sheets contain pertinent information that you may need to protect your employees and customers against any known health or safety hazards associated with our products. Users should review the latest MSDS to determine possible health hazards and appropriate precautions to implement prior to using this material. Copies of the latest MSDS may be requested by calling our customer service group at 800-367-8793 or emailing your request to adhesives_group@huntsman.com

To protect against any potential health risks presented by our products, the use of proper personal protective equipment (PPE) is recommended. Eye and skin protection is normally advised. Respiratory protection may be needed if mechanical ventilation is not available or is insufficient to remove vapors.

For detailed PPE recommendations and exposure control options consult the product MSDS or a Huntsman EHS representative.

FIRST AID :

Eyes and skin : Flush eyes with water for 15 minutes. Contact a physician if irritation persists. Wash skin thoroughly with soap and water. Remove and wash contaminated clothing before reuse.

Inhalation : Remove subject to fresh air.

Swallowing : Dilute by giving water to drink and contact a physician promptly. Never give anything to drink to an unconscious person.

KEEP OUT OF REACH OF CHILDREN

FOR PROFESSIONAL AND INDUSTRIAL USE ONLY

IMPORTANT LEGAL NOTICE

Huntsman Advanced Materials warrants only that its products meet the specifications agreed with the user. Typical properties, where stated, are to be considered as representative of current production and should not be treated as specifications.

The manufacture of materials is the subject of granted patents and patent applications; freedom to operate patented processes is not implied by this publication.

WHILE ALL THE INFORMATION AND RECOMMENDATIONS IN THIS PUBLICATION ARE, TO THE BEST OF HUNTSMAN ADVANCED MATERIAL'S KNOWLEDGE, INFORMATION AND BELIEF, ACCURATE AT THE DATE OF PUBLICATION, nothing herein is to be construed as a warranty, whether express or implied, including but without limitation, as to merchantability or fitness for a particular purpose. In all cases, it is the responsibility of the user to determine the applicability of such information and recommendations and the suitability of any product for its own particular purpose.

The behavior of the products referred to in this publication in manufacturing processes and their suitability in any given end-use environment are dependent upon various conditions such as chemical compatibility, temperature, and other variables, which are not known to Huntsman Advanced Materials. It is the



Enriching lives through innovation

responsibility of the user to evaluate the manufacturing circumstances and the final product under actual end-use requirements and to adequately advise and warn purchasers and users thereof.

Products may be toxic and require special precautions in handling. The user should obtain Safety Data Sheets from Huntsman Advanced Materials containing detailed information on toxicity, together with proper shipping, handling and storage procedures, and should comply with all applicable safety and environmental standards.

Hazards, toxicity and behavior of the products may differ when used with other materials and are dependent on manufacturing circumstances or other processes. Such hazards, toxicity and behavior should be determined by the user and made known to handlers, processors and end users.

Except where explicitly agreed otherwise, the sale of products referred to in this publication is subject to the general terms and conditions of sale of Huntsman Advanced Materials LLC or of its affiliated companies including without limitation, Huntsman Advanced Materials (Europe) BVBA, Huntsman Advanced Materials Americas Inc., and Huntsman Advanced Materials (Hong Kong) Ltd. Huntsman Advanced Materials is an international business unit of Huntsman Corporation. Huntsman Advanced Materials trades through Huntsman affiliated companies in different countries including but not limited to Huntsman Advanced Materials LLC in the USA and Huntsman Advanced Materials (Europe) BVBA in Europe.

Araldite is a registered trademark of Huntsman Corporation or an affiliate thereof in one or more, but not all, countries.

Copyright © 2007 Huntsman Corporation or an affiliate thereof. All rights reserved.

Main Offices :

Huntsman Corporation
10003 Woodloch Forest Dr.
The Woodlands
Texas 77380
(281) 719-6000

**Huntsman Advanced Technology
Center**

8800 Gosling Rd.
The Woodlands
Texas 77381
(281) 719-7400
Website :
www.huntsman.com/advanced_materials

Appendix C: ART Flex-TEC Technical Specifications



FLEX-TEC HV® Flexible Repair Compound

MANUFACTURER

Advanced Repair Technology, Inc.

PO Box 510 Cherry Valley, New York 13320
607.264.9040

PRODUCT DESCRIPTION

Flex-Tec HV is a two component epoxy material designed specifically for strength and flexibility. Engineered to move with the natural expansion and contraction of various natural and synthetic materials, Flex-Ease offers outstanding long-term performance. Excellent modeling and tooling properties make Flex-Ease the ideal choice for the professional or casual user.

Flex-Tec HV can be used on both vertical and horizontal surfaces. Common applications are on exterior column bases, window sills and sashes, and architectural wood ornaments. It is also suitable for various manufacturing uses, the repair of natural wood imperfections such as knots or checks, and the sealing of end-grain. Flex-Tec HV is ideal for synthetic materials such as cellular PVC trim boards and fiberglass.

APPLICATION LIMITATIONS

- A** Do not apply over damp or contaminated/decayed surfaces.
- B** Designed to be used in concert with Prime-A-Trate Flexible Cell bonding primer.
- C** Always apply varnish or paint after completing the repair.

COLOR

Controlled mixing system turns amber after proper blending. Staining can be achieved by adding dry pigment during the mixing process. Gel stains can be used after curing.

INSTALLATION

(See separate application instructions for complete details.)

TECHNICAL DATA

*Refer to table below for typical properties**

**For information only. Not for specification purposes.*

Performance Properties	Results	Test Method
Mix Ratio, by volume	2 to 1	
Mixed Viscosity, cps	Paste	
Tensile Strength, psi	7,500	ASTM D-638
Flexural Strength, psi	16,500	ASTM D-790
Compression Strength, psi	14,000	ASTM D-695
Elongation, %	6.0	
Hardness, Shore D	7.5	
Coefficient of Thermal Exp., in/in	60 x 10 ⁻⁶	ASTM D-1674
Linear Shrinkage, %	<1%	ASTM D-2566
Peel Strength, psi	30	ASTM D-1876
Moisture Absorption, %	1.0	ASTM D-570
Pot Life, Minutes, 200 gm	20-30	
Specific Gravity, g/cc	1.02	ASTM D-1475
VOC Content, lb/gal	0	
Chemical/Fuel Resistance	Excellent	
Cure Schedule	Room Temp for 24 hours	

PACKAGING

Flex-Tec HV is available in 450ml dual cartridge dispensing system using a heavy or light duty dispensing gun. 150ml single cartridge fits into a standard caulk gun and dispenses both A & B components. Both dispensing systems are re-sealable.

MIXING

A disposable static mixing nozzle blends the resin and hardener automatically and thoroughly to facilitate proper dispensing. The automatic proportioning in the mixing nozzle assures precise, consistent formulation. Material can also be dispensed on to a flat surface and mixed by hand using a putty knife.

WORKING TEMPERATURES

45 to 95 degrees Fahrenheit. Avoid working in direct sun light. Curing time will be extended in temperatures below 45 degrees. *(See graph on back.)*

VISIT US ON THE WEB!

WWW.ADVANCEDREPAIR.COM FOR TECH SUPPORT & HOW TO DEMOS



Advanced Repair Technology, Inc.

The Science of Repair

How Thickness and Temperature Effect Cure Times
(times are approximate)

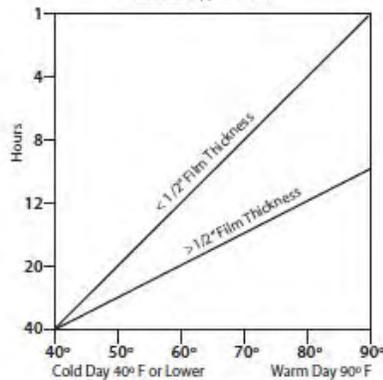

TOOLING

The unique modeling characteristics of Flex-Tec HV allows for both vertical and horizontal applications without the requirement for "dams" or molds to contain the material while curing. In most cases, a simple putty knife can properly position the material to desired shape. After mixing, Flex-Tec HV has an open time of 20 to 30 minutes. After a curing time of 16 hours, Flex-Tec HV can be sanded, chiseled or drilled. Shrinkage during curing is less than 1%.

SAFETY AND HANDLING

Flex-Tec HV contains no VOCs. Avoid direct contact with skin. Do not take internally. Consult Material Safety Data Sheets for complete information.

CLEANING

Immediately remove all excess material from adjacent areas. Properly mask all adjacent porous surfaces to avoid penetration. For skin contact, wash with soap and water, household vinegar or citrus oil.

SHELF LIFE

3 years when stored in unopened, original container. 2 years once opened. Store in cool, dry area.

TECHNICAL SERVICES

Advanced Repair Technology is committed to offering the best technical support available. Existing condition assessments, cost estimates, repair vs. replacement options, Contractor Workshops, site surveys and core sample testing are all services offered by ART or their Sales Representatives. Specification assistance also available.

AVAILABILITY AND COST

All Products and services are available throughout the United States via UPS shipments from the home office or by contacting your local retailer.

WARRANTY

All recommendations, statements and technical data contained herein are based on tests we believe to be reliable and correct, but accuracy and completeness of said tests are not guaranteed and are not to be construed as a warranty, either expressed or implied. User shall rely on his own information and tests to determine suitability of the product for intended use, and user assumes all risk and liability resulting from the use of the product. Manufacturer and its representatives sole responsibility shall be to replace that portion of the product of the manufacturer which proves to be defective. Manufacturer shall not be liable to the buyer or any third party for injury, loss, or damage directly or indirectly resulting from the use of, or inability to use the product. Recommendations or statements other than those contained in a written agreement signed by an officer of the manufacturer shall not be binding upon the manufacturer.

STRUCTURAL APPLICATIONS

Due to the high flexural modulus of the Advanced Repair Technology's repair products, we recommend consulting a structural engineer to design a specific load bearing recommendation.

PRODUCT REVERSIBILITY

For conservation projects that require the products specified to be "reversible" in nature, Flex-Tec HV can be fully removed at any time using a Methylene-Chloride based paint stripping compound.

AGE CURING PROPERTIES

Flex-Tec HV is formulated with age curing inhibitors. ACT'S block continued cross-linking common in flexible epoxy systems. ACT'S prohibit Flex-Tec HV from becoming brittle over time, protecting the property of flexural strength (ASTM-D-790)

Revised April 2013

ADVANCED REPAIR TECHNOLOGY • P.O. Box 510 • Cherry Valley, NY 13320
Phone: 607-264-9040 • Tech Support: 866-859-2787 • Fax: 607-264-8307
Email: contactadvancedrepair@gmail.com

VISIT US ON THE WEB! WWW.ADVANCEDREPAIR.COM FOR TECH SUPPORT & HOW TO DEMOS

Appendix D: Conserve 100 Technical Specifications



"From hands-on professionals...For hands-on preservationists"

P.O. Box 454 Northford, CT 06472 phone (203) 484-4123 fax (203) 484-2398 www.conservepoxy.com

INSTRUCTIONS

FLEXIBLE EPOXY CONSOLIDANT **100** & **W100**

ConServ 100 FLEXIBLE EPOXY CONSOLIDANT is a non-structural, slow curing, low viscosity epoxy system designed for saturating and encapsulating wood decay, or priming damaged areas. **W100** is a faster curing version designed especially for cold weather applications. The properties are ideally suited for consolidating and stabilizing pockets of wood decay, checks, fissures and other surface imperfections likely to sustain damage due to exposure, infestation or minor charring from fire damage. Applications include end grain, window and door sills, sash, jambs, trim, siding, porch elements, stairs, framing, and log and timber elements. Use as a stabilizing primer for **ConServ 200** Flexible Epoxy Patch.

NOTICE: Labels & literature are *color coded* for proper identification. *Please take time* to acquaint yourself with *all* labels, instructions & precautions *before* mixing. View instructional videos at www.conservepoxy.com. Due to the variety of uses, methods of application & types of conditions, results of this product cannot be anticipated. No warranty is written or implied.

WOOD PREPARATION normally involves removing most of the loose and soft decay close to good wood prior to the application of the epoxy consolidant. If serious decay exists and if possible, drill 1/8" to 3/8" holes close together in the decay zone to provide for better penetration. Wood to be consolidated should be *clean* and *dry* with a moisture content below 20%.

MIXING EPOXY: *Put the A resin can on ice* & keep in shade to slow the curing process and increase pot life. *This is recommended for the 100, but especially important for the W100 or either in large batches which cure faster.* Pour the contents of bottle B (curing agent) into container A (epoxy resin). Blend *thoroughly* for three minutes by hand with a firm flat stick or use a power mixer. If you intend to use less than a full set, the preferred method is to break down components A & B into sets of equal parts & return A into metal cans & B into plastic bottles. A simple break down video is on our website. Or, see the Technical Data sheet for more options.

CAUTION: Stored Resin (A) may *crystallize* in cool temp. causing a white *waxy* substance to form on the bottom of the can. This condition can easily be corrected & *does not* in any way alter or inhibit the effectiveness of the epoxy. *Dissolve* by gradually warming in direct sun, use a hair dryer, heat gun or carefully place the A can in boiling water or a double boiler and stir gently until the material is almost clear. **Do not over heat.** Allow epoxy to regain normal room temperature before using.

APPLYING CONSOLIDANT is best done in temperature range of 50°-90°F. When temperature is out of range, special accommodations are required to increase the rate of cure for colder conditions (use **W100**). Our original 100 formula is our slowest curing product, so it *can* be used in warmer temperatures, but if possible, avoid applying epoxy in direct sunlight with extremely hot weather, or rain. Apply **100** by funneling into a narrow mouth bottle capped with a spout for squirting & pouring, to *saturate* areas like checks and fissures. Or brush on directly from the can or a wide mouth bottle. Spraying is only recommended for professionals. Consolidate repeatedly until the wood glosses over and accepts no more epoxy. Remember, the objective is *deep penetration* to encapsulate and stabilize any remaining decay. Protect treated areas using poly wrapped/ tented over work to keep materials warm & dry until epoxy has set. Protect unaffected areas from overspray or spills.

CURING: **ConServ 100 Consolidant** cures in 3-5 days, and **W100** in 2-3 days at 72° F or room temperature. The **100** cures slowly in hot weather and **W100** cures slow enough in cold for maximum penetration. Heat causes epoxy to cure faster. Before applying **ConServ 200 Patch**, consolidants *need not* be fully cured. Apply **200** immediately (preferred) or at a later date.

CLEAN-UP AND STORAGE: **ConServ 100** series epoxy consolidant has a one year shelf life when stored at room temperature in closed containers. Tools may be wiped clean with dry paper towels before full cure. Deposit paper towels and containers in a plastic bag and discard with trash for incineration. White vinegar will soften cured epoxy on tools or equipment if allowed to soak for an extended period of time. Acetone, Methylene chloride and MEK softens the epoxy for easy removal, but should be avoided due to their toxicity.

EPOXY SAFETY is a function of common sense and good housekeeping. *Wear disposable nitrile or latex gloves, eye protection, and old clothing.* Don't get epoxy on your skin or clothes. Work with good ventilation.

(see reverse side for TECHNICAL DATA)

Revised 07/2013



"From hands-on professionals...For hands-on preservationists"
 P.O. Box 454 Northford, CT 06472 phone (203) 484-4123 fax (203) 484-2398 www.conservepoxy.com

TECHNICAL DATA

FLEXIBLE EPOXY CONSOLIDANT **100** & **W100**

ConServ 100 FLEXIBLE EPOXY CONSOLIDANT is a non-structural, slow curing, low viscosity epoxy system designed for saturating and encapsulating wood decay, or priming damaged areas. **W100** is a faster curing version designed especially for cold weather applications. The properties are ideally suited for consolidating and stabilizing pockets of wood decay, checks, fissures and other surface imperfections likely to sustain damage due to exposure, infestation or minor charring from fire damage. Applications include end grain, window and door sills, sash, jambs, trim, siding, porch elements, stairs, framing, and log and timber elements. Use as a stabilizing primer for **ConServ 200** Flexible Epoxy Patch.

MEASURING EPOXY: Breakdown Video shows one method, or by volume and weight as follows:

<u>By Volume</u>		<u>By Weight</u>	
100	ratio of 4 A : 1 B	100	ratio of 4.5 A : 1 B
W100	ratio of 3.25 A : 1 B	W100	ratio of 3.5 A : 1 B

CURE SCHEDULE

Pot life **100** 4 fl oz - approx. 4-6 hrs. @ 72° F
 Gel time 4 fl oz - approx. 1½-3 days @ 72° F
 Final cure 3-5 days @ 72° F (approx. 75% cured)

Pot life **W100** 4 fl oz - approx. 1-2 hrs. @ 72° F
 Gel time 4 fl oz - approx. 12-24 hrs. @ 72° F
 Final cure 2-3 days @ 72° F (approx. 75% cured)

DO NOT use below 50° F.
AVOID exposure to intense sunlight until final cure is complete.

PROPERTIES

Color Clear
 Viscosity Consistency of vegetable oil @ 72° F
 Operating range -30° F to 160° F
 Mixing temp. range 50° F to 90° F
 Shelf life 1 year in unopened original containers

PACKAGING & YIELD

ConServ 100 & **W100** are supplied in ½ gallon, 1 quart, 1 pint, ½ pint, ¼ pint and 2 fl oz quantities. **Coverage is variable** depending on the extent of the decay and subsequent degree of saturation. Sufficient saturation to stabilize the damaged material is imperative for proper protection and preparation for the **ConServ 200** patch.

(See reverse side for INSTRUCTIONS)

Revised 07-2013

Appendix E: PC Rot Terminator Technical Specifications



PC-Rot Terminator

Restore / Repair Severely Rotted & Insect Damaged Wood



Description:

PC-Rot Terminator® is structural wood hardener designed to strengthen decayed or rotted wood. The mixture is a low viscosity liquid that penetrates porous surfaces filling and sealing voids with an epoxy that cures to a hard but durable component. PC-Rot Terminator® is useful for replacement of missing wood fibers or wood resin. PC-Rot Terminator® fills the voids in the wood with an elastomer that has strength greater than wood. PC-Rot Terminator® acts as a binder that glues the wood fibers together. The wood fibers become much stronger in combination with the epoxy elastomer.

Solvent Free: PC-Rot Terminator® contains 100% active ingredients and does not contain solvents which may evaporate and cause shrinkage.

Directions:

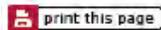

Wood Hardening: Worn and weathered wood can be rejuvenated with PC-Rot

Terminator®. The surface can be made harder and less crumbly. A desk surface or hardwood floors can be made harder and wear resistant if the wood is ready to accept the epoxy consolidate. Seal the wood from the effect of wear and weather.

Adhesive: PC-Rot Terminator® can be used as an adhesive on non porous surfaces. The mixture becomes thicker after 90 minutes of working time allowing for higher build and increased glue lines.

Penetration: PC-Rot Terminator® will readily follow the grain of rotted wood. Removal of paint and varnish will increase the acceptance of the consolidant. For maximum penetration poke or drill holes into the wood or expose the grain of the wood by cutting into the wood. For vertical surfaces drill holes on an angle to hold PC-Rot Terminator®. Reapply the PC-Rot Terminator® prior to cure if needed.

Applicators: The epoxy consolidant can be applied using and acid or paint brush or a paint roller until the area is fully saturated. The applicator bottle can be used to inject into drilled holes or larger openings in the wood. Do not attempt to spray outside of a paint spray booth.

Painting: Stain sealing primer or oil based primer are recommended.

Additional Information

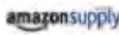
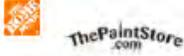
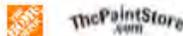
<p>Available Sizes - Links to Purchase:</p> <ul style="list-style-type: none"> • UNIT SIZES • PART # • PURCHASE LINKS <p>• 3.25 Fl OZ • 350614</p> <p>•    24 Fl OZ • 240618</p> <p>•  </p> <p>• 1.5 Gallon • 192610</p> <p>•    </p>
<p>Cure Rate:</p> <p>The cure rate in the thicker sections is faster than in the thin sections. The greater the temperature, the faster the cure time. PC-Rot Terminator® cure can be accelerated using a light bulb or other gentle heat source. The cure rate is halved for every 20°F increase. After cure (roughly 24 hours) fill in missing pieces with PC Woody® paste epoxy.</p>
<p>Coverage:</p> <p>One unit of 24 ounces will seal 50 to 100 square feet of deck as a sealer. For severely rotted wood, one unit will treat 500 to 2500 cubic inches. The amount of usage depends on the porosity of wood. Damp wood that is heavy with water will not accept the maximum amount of the mixture. PC-Rot Terminator® can not displace water in wood.</p>
<p>Chemical Resistance:</p> <p>PC-Rot Terminator® can be used as a protective coating. The epoxy has an excellent resistance to solvents such as xylene, toluene, ethanol, water and caustics. PC-Rot Terminator® is not recommended for M.E.K. butylocellusolve or acids.</p>
<p>PC-Rot Terminator® - versatile uses.</p> <p>Masonry uses: PC-Rot Terminator® can be used to seal and protect concrete, brick and stone surfaces. Use for chemically resistant linings, mortar and secondary containment linings. Excellent for flooring and repairing cracked plaster.</p> <p>Sealer: Protect drywall from water and moisture. Seal particle board and plywood around plumbing fixtures. Protect where there is condensation or leaks. Seal wood posts and end grain. Seal garage floors (floor should be clean and dry before application).</p>

Marine: PC-Rot Terminator® can be used to repair fiberglass boats. Repair holes and punctures using PC-Rot Terminator® to wet out the surface and PC-11® and PC-7® paste epoxy as a filler. Use as a barrier coating for repaired hull. Secure loose hardware. Repair areas of delaminating fiberglass or wood. Seal cracks and scratches.

DO NOT ATTEMPT TO GEL COAT OVER EPOXY REPAIRS.

Epoxy Repairs: Repair dry rot on a wooden boats surface, deck, trim, hull and planking. Repair docks. Remove splinters from rails and board walks.

[View All Uses](#)

What Causes Wood Rot

The microscopic organisms that discolor and decay wood belong to a group of primitive plants known as fungi. Unable to produce their own food, fungi feed instead on natural substances (symbiosis) that make up organic materials like leather, cloth, paper, and of course wood.

These organisms release millions of dust-size spores that are distributed by air movement. These spores germinate, producing thread-like filaments called hyphae. The enzymes secreted by hyphae break down organic matter so fungi can feed on it.

Before this fungi can attack wood, certain requirements must be met: oxygen must be present, temperatures must be in the 40 to 100 degree Fahrenheit range, there must be a supply of sufficient moisture, and there has to be a food source. Infection can be prevented by eliminating any one of these requirements.

The most effective "method" of preventing fungal deterioration of wood is to keep it dry. The decay of the wood is caused by the chemicals dissolving nutrients in the wood, the nutrients are then absorbed by the fungal hyphae, enabling the growth to take place. If the moisture content is high enough the growth extends through the wood via a network of fine threads called mycelium. As with any fungus, the spores are ever present in the dormant stage, awaiting proper conditions to grow. At this time, some of the filaments penetrate below the surface, first softening and then destroying the wood.

Types of Wood Rot

Decay fungi fall into three major groups: brown rots, white rots, and soft rots.



Brown rots are so-named because infected wood turns dark brown. When dried, wood previously infested will turn to powder when crushed. Many times, old infestations of brown rot which have dried out are labeled as "dry rot." This is really a deceiving term since wood will not decay when dry.

White rots show a white, gray-white, yellow-white, or bleached appearance to wood. Most often infecting hardwoods. In advanced stages of decay, white-rotted wood is spongy, has a stringy texture, and lacks the checking of brown-rotted wood. A thin black line often marks the advancing edge of white rot in hardwoods.



Soft Rots: Most decay fungi are unable to conduct water very far and can only attack moist wood. However, *Poria incrassata*, called dry rot or the water-conducting fungus, will decay wood which would not be attacked by typical decay fungi. *Poria* infested wood is often mistakenly identified as subterranean termite damage. This type of fungus can transport water for several feet through large root-like structures called rhizomorphs. Once established, it can quickly spread through a building and destroy large areas of flooring and walls in as little as a year or two.

Insect Damage



Subterranean termites are the most destructive insect pests of wood in the United States. They cause more than \$2 billion in damage each year: more property damage than is caused by fire and windstorm combined. Several species of subterranean termites are found in the United States; they live in every state except Alaska.

Carpenter ants damaged wood by hollowing it out for nesting. Their excavated galleries in the wood have a smooth, sandpapered appearance. Wood which has been damaged by carpenter ants contains no mud-like material, as is the case with termites. Shredded fragments of wood, similar in appearance to coarse sawdust, are ejected from the galleries through preexisting cracks

or slits made by the ants.



Powderpost beetles are so called because in high numbers they are able to turn the inside of a piece of wood into nothing more than a mass of fine powder. These wood destroying beetles can do significant damage to log homes, furniture, wood floors and structural timbers in your home. Powderpost beetles are small (1/8 inches) and the adult beetles are seldom seen. Most of the life cycle is spent in the grub or larvae stage eating wood. Damage is done by the larvae as they create narrow, meandering tunnels in wood as they feed.

Physical Properties

- Work Time:
- 80 minutes
- Thin Film Set:
- 12 Hours
- Cure for Service:
- 24 Hours
- Maximum Cure:
- 7 Day
- Compressive Modulus:
- 230000 Psi
- Compressive Yield Strength:
- 6500 PSI
- Tensile Strength:
- 4500 PSI
- Tensile Modulus:
- 210000 PSI
- Tensile Enlongation at Break:
- 12%
- Flexural Strength:
- 9500 PSI
- Flexural Modulus:

- 300000 PSI
- Hardness Shored:
 - 78
- Mar Resistance:
 - 1.05 Kg

Technical Data

[Rot Terminator, Hardener MSDS Sheet](#)
[Rot Terminator, Resin MSDS Sheet](#)

Spanish/French

[Info Sheet](#)

Appendix F: Rotafix Resiwood TG6 Technical Specifications



RESIWOOD® SYSTEM TG6 TIMBER GROUT

PRODUCT CODE: 3480 - 2.5 litre pack: 3482 – 7.5 litre (multi pack)
DESCRIPTION: TG6 TIMBER GROUT is one of a series of specially developed epoxy resin systems for the structural repair of timber.

PACKAGING: TG6 TIMBER GROUT is supplied in 5 litre or 20 litre plastic pails. Each pail contains the correct amount of filler, resin and curing agent for the appropriate pack size. (See mixing instructions)

PREPARATION: Timber surfaces should be clean, free from dust and loose or friable particles.
 TG6 TIMBER GROUT is free flowing and very searching. Any cracks or apertures must be adequately sealed with Rotafix P7 BONDING PASTE before mixing and pouring. Where timber preservatives are involved, please consult our Technical Department.



MIXING: The contents of the base resin container/s and the curing agent container/s should be thoroughly mixed in the outer container. The total amount of the filler is then added to the liquid and mixed for 2-3 minutes. Mechanical mixing using the appropriate Rotafix paddle is strongly advised for the 2.5 litre pack and essential for the 7.5 litre pack. The 7.5 litre pack is made up of 3 x 2.5 litre units. If the full 7.5 litres is to be used then all packs need to be mixed in one container. The 2.5 litre units can also be mixed individually if a smaller amount of material is required.

APPLICATION: The volume of material required for a particular pour should be pre-calculated. The mixed TG6 TIMBER GROUT should then be poured or pumped in such a way that there is a continuous head.



COVERAGE: When mixed both pack sizes of TG6 TIMBER GROUT will give the stated volumes of finished grout. As a guide, an 7.5 litre pack would fill a void of 100mm x 100mm x 750mm

CURE SCHEDULE: Rate of cure and exotherm will be related to ambient temperature, material temperature, volume of material poured and the aspect ratio of the pour. For specific information on individual placements in excess of 50 litres please consult our Technical Department.

Workability:	Cure Schedule	Peak Exotherm	
		Not insulated	Insulated
90 mins at +10°C	3 Days at + 10°C	At 10°C to 20°C	30°C
50 mins at + 20°C	2 Days at + 20°C	At 20°C to 25°C	40°C
30 mins at + 30°C	2 Day at + 30°C	At 30°C to 45°C	60°C

CURED PROPERTIES:



Compressive strength >50N/mm². Tensile strength 17N/mm²) Provisional
 Specific Gravity 1.6 Flexural strength 32N/mm²)
 Static Modulus of Elasticity E_c 8.3 9KN/mm²)
 Standard colour - Dark Green Colour stable
 Minimum application temperature +5°C.

SPECIFIC USES: Replacement of decayed timber, timber beam upgrading.

CLEANING TOOLS: Uncured TG6 TIMBER GROUT may be readily removed with Rotafix \$200 PC Solvent Cleaner. Mechanical methods are required to remove cured material.

The requirements for a Rotafix product(s) may be specific for an individual project.
 Advice given by Rotafix can only be considered as part of the contract if it is provided in writing.
 Epoxy resins and their associated curing agents can cause irritation to some people.
 Please take the necessary precautions indicated in the COSHH details available from our offices.
 Please read our Users Safety Guide on the Handling of Resin and Polymer products.

The information in this document is based on practical tests, but given without guarantee inasmuch as methods of use by others is beyond our control. Due to continuing development and improvements, it may be necessary to change without notice the material specification. All goods are sold subject to our Standard Conditions of Sale.

RESIWOOD is a Registered Trade Mark of Rotafix (Northern) Ltd



ROTAFIX, ROTAFIX HOUSE, ABERCRAF,
 SWANSEA SA9 1UR. U.K.
 TEL: +44 (0)1639 730481 FAX: +44 (0)1639 730858
 e.mail: sales@rotafix.co.uk web site: www.rotafix.co.uk

SOUTHERN AREA CONTACT:
 TEL: +44 (0)1442 243169 FAX: +44 (0)1442 234901
 PD3480-3/version 3

Appendix G: Sikadur 32 Hi Mod Technical Specifications

Product Data Sheet
Edition 8.1.2011
Sikadur 32, Hi-Mod

Sikadur® 32, Hi-Mod

High-modulus, high-strength, epoxy bonding/grouting adhesive

Description	Sikadur 32, Hi-Mod, is a multi-purpose, 2-component, 100% solids, moisture-tolerant structural epoxy adhesive. It conforms to the current ASTM C-881, Types I, II, and V, Grade-2, Class C and AASHTO M-235 specifications.
Where to Use	<ul style="list-style-type: none"> ■ Bond fresh, plastic concrete to hardened concrete and steel. ■ Grout horizontal cracks in structural concrete and wood by gravity feed. ■ Machinery and robotic base-plate grout. ■ Structural adhesive for concrete, masonry, metal, wood, etc.
Advantages	<ul style="list-style-type: none"> ■ Super-strength bonding/grouting adhesive. ■ Tolerant to moisture before, during and after cure. ■ Excellent adhesion to most structural materials. ■ Convenient easy-to-mix ratio A:B = 1:1 by volume. ■ Easy-to-use for bonding/grouting applications. ■ Fast initial set; rapid gain to ultimate strengths. ■ USDA-certified for use in food plants.
Coverage	<p>Bonding Adhesive - 1 gal. covers approximately 80 sq. ft. on smooth surface.</p> <p>Base Plate Grout - 1 gal. mixed with 1.5 parts oven-dried aggregate by loose volume yields approximately 420 cu. in. of grout.</p> <p>Anchoring grout - 1 gal. yields 231 cu. in. of grout.</p>

Typical Data (Material and curing conditions @ 73°F (23°C) and 50% R.H.)

RESULTS MAY DIFFER BASED UPON STATISTICAL VARIATIONS DEPENDING UPON MIXING METHODS AND EQUIPMENT, TEMPERATURE, APPLICATION METHODS, TEST METHODS, ACTUAL SITE CONDITIONS AND CURING CONDITIONS.

Shelf Life	2 years in original, unopened containers.			
Storage Conditions	Store dry at 40°-95°F (4°-35°C). Condition material to 65°-75°F (18°-24°C) before using.			
Color	Concrete gray			
Mixing Ratio	Component 'A': Component 'B' = 1:1 by volume.			
Viscosity	Approximately 3,000 cps.			
Pot Life	Approximately 30 minutes. (60 gram mass). Approximately 22 minutes. (350 gram mass, 8 oz.)			
Contact Time	40°F (4°C)*: 12 hrs.	73°F (23°C)*: 3-4.5 hrs.	90°F (32°C)*: 1.5-2 hrs	
Compressive Modulus, psi	7 day	2.1 X 10 ⁶ psi (1,449 MPa)		
Tensile Properties (ASTM D-638)				
	7 day	Tensile Strength	6,000 psi (48 MPa)	
		Elongation at Break	1.9%	
	14 day	Modulus of Elasticity	5.4 X 10 ⁶ psi (3,726 MPa)	
Flexural Properties (ASTM D-790)				
	14 day	Flexural Strength (Modulus of Rupture)	7,000 psi (48.3 MPa)	
		Tangent Modulus of Elasticity in Bending	6.9 X 10 ⁶ psi (4,800 MPa)	
Shear Strength (ASTM D-732)	14 day	Shear Strength	6,200 psi (43 MPa)	
Water Absorption (ASTM D-570)	7 day	(24 hour immersion)	0.21%	
Heat Deflection Temperature (ASTM D-648)				
	7 day	[fiber stress loading 264 psi (1.8 MPa)]	122°F (50°C)	
Bond Strength (ASTM C-882):				
	2 day (moist cure)	Plastic Concrete to Hardened Concrete	1,700 psi (11.7 MPa)	
		Hardened Concrete to Hardened Concrete	2,000 psi (13.8 MPa)	
		Hardened Concrete to Steel	1,900 psi (13.1 MPa)	
	14 day (moist cure)	Plastic Concrete to Hardened Concrete	2,200 psi (15.1 MPa)	
		Plastic Concrete to Steel	2,000 psi (13.8 MPa)	
		Hardened Concrete to Hardened Concrete	2,000 psi (13.8 MPa)	
Compressive Properties (ASTM D-695)				
Compressive Strength, psi (MPa)		40°F* (4°C)	73°F* (23°C)	90°F* (32°C)
	8 hour	-	140 (1.0)	1,700 (11.7)
	16 hour	-	4,800 (33.1)	7,300 (50.3)
	1 day	30.0 (0.2)	5,700 (39.3)	7,300 (50.3)
	3 day	5,300 (36.6)	11,300 (77.9)	10,400 (71.7)
	7 day	9,600 (66.2)	11,800 (81.4)	10,400 (71.7)
	14 day	11,900 (82.1)	12,200 (84.1)	10,400 (71.7)
	28 day	12,600 (86.9)	12,200 (84.1)	10,500 (72.4)

*Material cured and tested at the temperatures indicated.



Packaging	1, 2 and 4 gal. units.
How to Use	Surface must be clean and sound. It may be dry or damp, but free of standing water. Remove dust,
Surface Preparation	laitance, grease, curing compounds, impregnations, waxes and any other contaminants. Preparation Work: Concrete - Should be cleaned and prepared to achieve a laitance and contaminant free, open textured surface by blastcleaning or other equivalent mechanical means. Steel - Should be cleaned and prepared thoroughly by blastcleaning.
Mixing	Pre-mix each component. Proportion equal parts by volume of Component 'A' and Component 'B' into clean pail. Mix thoroughly for 3 minutes with Sika paddle on low-speed (400-600 rpm) drill until blend is a uniform color. Mix only that quantity that can be applied within its pot life.
Application	To bond fresh concrete to hardened concrete - Apply by brush, roller, broom or spray. Place fresh concrete while Sikadur 32, Hi-Mod, is still tacky. If coating becomes glossy and loses tackiness, remove any surface contaminants then recoat with additional Sikadur 32 Hi-Mod, and proceed. To grout baseplates - Add up to 1 1/2 parts of oven-dried aggregate to 1 part of mixed Sikadur 32, Hi-Mod, by volume. Place grout under baseplate. Avoid contact with the underside of the plate. A 1/4 to 3/8 in. (6 to 10 mm) space should remain between the top of the grout and the bottom of the plate. Maximum thickness of grout per lift is 1.5 in. (38 mm) If multiple lifts are needed, allow preceding layer to cool to touch before applying additional layer. The remaining 1/4 to 3/8 in. (6 to 10 mm) space should be filled with neat Sikadur 32 Hi-Mod. Pour a sufficient quantity of neat epoxy to allow the level to rise slightly higher than the underside of the bearing plate. To gravity feed cracks - Pour neat material into vee-notched crack. Continue placement until completely filled. Seal underside of slab prior to filling if cracks reflect through.
Limitations	<ul style="list-style-type: none"> ■ Minimum substrate and ambient temperature 40°F (4°C). ■ For spray applications, consult Technical Service at 800-633-7452. ■ Use only oven-dry aggregate. ■ Material is a vapor barrier after cure. ■ For applications on exterior, on-grade substrates, consult Technical Services at 800-633-7452. ■ Do not apply over wet, glistening surface. ■ Not an aesthetic product. Color may alter due to variations in lighting and/or UV exposure.
Warning	Component 'A' - IRRITANT; SENSITIZER - Contains epoxy resin, nonyl phenol. Can cause skin sensitization after prolonged or repeated contact. Eye irritant. May cause respiratory irritation. Harmful if swallowed. Component 'B' - CORROSIVE; IRRITANT; SENSITIZER - Contains amines, silica (quartz), and benzylalcohol nonyl phenol. Contact with eyes or skin causes severe burns. Can cause skin sensitization after prolonged or repeated contact. Skin/respiratory/eye irritant. Harmful if swallowed. Deliberate concentration of vapors of Component A or B for purposes of inhalation is harmful and can be fatal. Cured material, if sanded, may result in exposure to a chemical known to the state of California to cause cancer.
First Aid	Eyes: Hold eyelids apart and flush thoroughly with water for 15 minutes. Skin: Remove contaminated clothing. Wash skin thoroughly for 15 minutes with soap and water. Inhalation: Remove person to fresh air. Ingestion: Do not induce vomiting. In all cases, contact a physician immediately if symptoms persist.
Clean Up	Wear chemical resistant gloves/goggles/clothing. Ventilate area. In absence of adequate general and local exhaust ventilation, use a properly fitted NIOSH respirator. Confine spill. Collect with absorbent material. Dispose of in accordance with current, applicable local, state and federal regulations. Uncured material can be removed with solvent. Strictly follow manufacturer's warnings and instructions for use. Cured material can only be removed mechanically.
Handling & Storage	Avoid direct contact with skin and eyes. Wear chemical resistant gloves/goggles/clothing. Use only with adequate ventilation. In absence of adequate general and local exhaust ventilation, use a properly fitted NIOSH respirator. Wash thoroughly after handling product. Launder clothing before reuse. Store in a cool dry well ventilated area.



KEEP CONTAINER TIGHTLY CLOSED • KEEP OUT OF REACH OF CHILDREN • NOT FOR INTERNAL CONSUMPTION • FOR INDUSTRIAL USE ONLY

All information provided by Sika Corporation ("Sika") concerning Sika products, including but not limited to, any recommendations and advice relating to the application and use of Sika products, is given in good faith based on Sika's current experience and knowledge of its products when properly stored, handled and applied under normal conditions in accordance with Sika's instructions. In practice, the differences in materials, substrates, storage and handling conditions, actual site conditions and other factors outside of Sika's control are such that Sika assumes no liability for the provision of such information, advice, recommendations or instructions related to its products, nor shall any legal relationship be created by or arise from the provision of such information, advice, recommendations or instructions related to its products. The user of the Sika product(s) must test the product(s) for suitability for the intended application and purpose before proceeding with the full application of the product(s). Sika reserves the right to change the properties of its products without notice. All sales of Sika product(s) are subject to its current terms and conditions of sale which are available at www.sikausa.com or by calling 800-633-7452.

Prior to each use of any Sika product, the user must always read and follow the warnings and instructions on the product's most current Technical Data Sheet, product label and Material Safety Data Sheet which are available online at www.sikausa.com or by calling Sika's Technical Service Department at 800-633-7452. Nothing contained in any Sika materials relieves the user of the obligation to read and follow the warnings and instructions for each Sika product as set forth in the current Technical Data Sheet, product label and Material Safety Data Sheet prior to product use.

LIMITED WARRANTY: Sika warrants this product for one year from date of installation to be free from manufacturing defects and to meet the technical properties on the current Technical Data Sheet if used as directed within shelf life. User determines suitability of product for intended use and assumes all risks. Buyer's sole remedy shall be limited to the purchase price or replacement of product exclusive of labor or cost of labor. **NO OTHER WARRANTIES EXPRESS OR IMPLIED SHALL APPLY INCLUDING ANY WARRANTY OF MERCHANTABILITY OR FITNESS FOR PARTICULAR PURPOSE. SIKASHALL NOT BE LIABLE UNDER ANY LEGAL THEORY FOR SPECIAL OR CONSEQUENTIAL DAMAGES. SIKASHALL NOT BE RESPONSIBLE FOR THE USE OF THIS PRODUCT IN A MANNER TO INFRINGE ON ANY PATENT OR ANY OTHER INTELLECTUAL PROPERTY RIGHTS HELD BY OTHERS.**

Visit our website at www.sikausa.com 1-800-633-SIKA NATIONWIDE

Regional Information and Sales Centers. For the location of your nearest Sika sales office, contact your regional center.

<p>Sika Corporation 201 Polito Avenue Lyndhurst, NJ 07071 Phone: 800-633-7452 Fax: 201-933-6225</p>	<p>Sika Canada Inc. 501 Delmar Avenue Pointe Claire Quebec H9R 4A8 Phone: 514-897-2510 Fax: 514-934-2792</p>	<p>Sika Mexicana S.A. de C.V. Carretera Libre Celaya Km. 8.5 Fracc. Industrial Balvanera Comisariado, Queretaro C.P. 76520 Phone: 52 442 2366800 Fax: 52 442 2250537</p>
--	---	---

Sika and SikaDur are registered trademarks. Printed in Canada.

Appendix H: Smith System CPES Product Literature

CPES™-Wood based epoxy products to repair and resist wood rot.

apply. It's that simple.

Minwax makes a wood hardener which is acrylic-based. This is not epoxy, is not nearly as strong, its long-term endurance is questionable, and in our experience its penetration is spotty. The solvents tend to leave the acrylic hardener behind, and it doesn't penetrate as well as CPES™. We do not recommend it.

What if you have resin on hand that you want to use? Will it bond with the CPES™? The answer is yes. Any epoxy or urethane resin/paint/coating will make a tight molecular bond with the CPES™. If you have resin on hand that you want to use, it'll work. It is also been suggested that you can heat a standard resin and possibly even the wood itself for greater penetration. We believe that heating polymer resins and wood is not a good idea -- for obvious reasons. It can be dangerous, the penetration will be much less than CPES™, and it will dry hard and brittle. Rocks in your wood again.

This stuff is very easy to use . . .

CPES™ is a two-component product with the consistency of diesel fuel, mixed 1:1, part A and part B. Apply by brush, solvent-resistant roller, sprayer, or inject by syringe until wood is completely saturated and will accept no more epoxy. Allow approximately 1-3 days for solvents to evaporate before applying paints, urethanes, varnishes, Fill-It™ Epoxy Filler or regular epoxy resin (see cure time chart below). Unmixed CPES, kept in closed cans and at above freezing temperatures, has a shelf life of over 5 years.

NOTE: Use disposable natural-bristle brushes (Foam brushes melt). For an excellent syringe, order Dr. Rot's [CPES Injection Kit](#) which also includes everything you'll need for the injection method. [Spray bottles w/funnels](#) are also available.

CLEAR PENETRATING EPOXY SEALER™ • CURE TIME CHART

Pot Life At Temperature	Warm Weather Formula	Cold Weather Formula
86°F/30°C	4 hours	Not Recommended
68°F/20°C	8 hours	2 hours
50°F/10°C	16 hours	4 hours
32°F/0°C	Not Recommended	8 hours
Full Cure Time Required		
86°F/30°C	2 days	Not Recommended
68°F/20°C	4 days	2 days
50°F/10°C	8 days	2 days
32°F/0°C	Not Recommended	4 days

The different temperature formulations are only applicable during application and for a few days while it is curing.

***WARNING:** This product is inherently unsafe. It cannot be made safe. That's why it works so well. We recommend the use of a respirator capable of filtering organic solvent fumes and vinyl gloves during application.*

Product Coverage and Shelf Life

Unmixed CPES, kept in closed cans and at above freezing temperatures, has a shelf life of over 5 years. If

<http://www.rotdoctor.com/products/cpes.html>[5/8/2014 5:11:10 AM]

you mix it, though, you must use it.

The coverage of CPESTM will depend entirely on the surface to which it is being applied. On rotted logs in log homes it can take a gallon every three to four feet to soak bad wood, yet for surface application on clean, sanded hardwood it can go about 300 sq. feet per gallon (7 sq. meters/liter). In any application of CPESTM the key is to allow the wood to absorb all that it can. It is especially important that CPESTM be applied generously to edges and end-grain areas because this is where the rot likes to get started.

To determine how much CPESTM you might need, use your best judgment based on the type, finish and condition of the wood. On new wood you can plan between 200 and 300 sq ft per gallon (5-7 sq meters/liter), although on rough, porous woods such as Cedar the coverage can go down to 100 sq ft per gallon (2.5 sq meters/liter). If the wood is rotted or deteriorated, or if there are large areas of end-grain, then it's pretty much a guess. Just look at the area that is going to be treated, imagine how much water it would absorb if generously applied, and that's going to be close to the amount of CPESTM you will require.

And remember -- the drier the wood the better the absorption. If you press the wood and water emerges then it's too wet for CPESTM treatment. If it's slightly damp application is okay, but you should always try to apply CPESTM to wood which is in the normal range, 12% to 20% moisture in average humidity conditions.

CPESTM USES & TECHNIQUES

For restoring rotted wood:

If the bad wood is accessible, we recommend tearing out all of the rot that can be reached. While you should remove all you can, there is no need to be obsessive about it. Large timbers may require drilled holes about 1/4", sloping downward, for the injection of the CPESTM. If there is a substantial amount of moisture present, the wood should be allowed to air dry, or, a technique we have used successfully on many occasions when time was important, use a hair dryer full blast to remove the moisture from the wood. We often simply prop the dryer into position and go about other tasks until the wood is moisture-free. Please be careful of nearby combustible materials. We have also used an air compressor blowing into drilled holes for the same effect. For large areas we've used the commercial kerosene heater/blowers rented by rent-all stores. The wood will get the dry, cracked, brittle surface appearance that bad wood has when the moisture has been removed.

Next, apply CPESTM by brush and/or syringe *generously* until the wood will accept no more and it pools or dribbles out of the rotted area. Allow the epoxy to fully cure (see time chart above). Next, depending on the situation, we do one of two things:

- (1) If the rotted area is on a horizontal surface so that the epoxy flows into it by gravity or you're saturating through drilled holes, we follow the cured CPESTM with our thicker Layup and Laminating™ Epoxy Resin. This is flowed into the area until it too begins to leak or flow out of the wood. After this has cured, we follow up with Fill-It™ Epoxy Filler. After curing, the filler/resins can be painted over as desired.
- (2) If the rotted area is on a vertical surface with no pockets for gravity flow, we simply follow up the CPESTM with a generously brushed coating of the Layup and Laminating™ Epoxy Resin and then the Fill-It™ Epoxy Filler. Fill-It™ filler applied directly over the CPESTM will work well, too. In either case, the wood fibers saturated with the CPESTM will form a bond with the resin or filler that cannot be achieved with either alone.

Sometimes the deteriorated wood is in such a location that tearing away at the wood is not practical. In this case, we use a long-shank 1/4" bit to drill downward sloping holes and determine the extent, type and degree of rot present. If the whole piece of wood is gone, then there's nothing to do but replace it. CPESTM is good but it won't work miracles. More often than not, there is still good wood around and the rot is reasonably dry.

A compressor with air hoses can be used to blow dry air through the wood if necessary. We then inject the CPES™ until it flows out the holes or runs out of the wood somewhere else. After curing, we follow this up with Layup and Laminating™ Epoxy Resin until the wood will accept no more. This sometimes must be done in multiple sequences until the void is effectively filled with cured resin. Occasionally there are pockets of "black mush", wood so far gone and wet that there is nothing to do but chisel through and scoop it all out. Dry with a hair dryer or blower and then follow the epoxy sequence outlined above.

The Use of Borates:

It is our opinion that anywhere that you are applying CPES, you don't really need to apply borates. However, if you wish to do so, some borate products can be used as a pre-treatment of deteriorated wood prior to the application of CPES -- as long as the borate is the *pure disodium octaborate tetrahydrate powder*. This powder is sold under several trade names. It is dissolved in water, applied to the wood, and then allowed to dry. After the wood is dry the CPES can be applied.

NOTE: DO NOT USE the disodium octaborate tetrahydrate in an ethylene glycol base. The glycols inhibit the ability of the CPES to penetrate. For more information on this, [click here](#)

As a primer on wood:

No matter what you plan as your finish coat on wood, CPES™ is a superior base. It not only dissolves any moisture and sap present, but penetrates the surface fibers like no other product on the market for a secure bond which will last for years. Paint (including Latex), varnish and one or 2-part polyurethane finishes will adhere better and last longer.

One generous coating of CPES™ is usually sufficient, although in areas that require additional protection multiple coats can be applied. CPES™ can be used over wood stains once they are completely dry. The CPES™ will not redistribute the stain in any way. *CPES™ is a light amber color and it's effect on the color of wood is about the same as normal varnish - it will darken it.*

When applied as a paint/varnish primer outdoors, apply early enough in the day to prevent evening dew/condensation from contaminating a wet CPES™ application.

CPES™ Application:

Choose warm or cold weather formula according to *the temperature at the time and place of application/cure.*

- Warm Weather Formula: 50°F (10°C) and higher
 - Cold Weather Formula: 28°F (-2°C) to 70°F (21°C)
- After curing the temperature variations do not matter.*

Mixing Containers: CPES™ can be mixed in polyethylene and polypropylene containers (plastic paint buckets, margarine tubs, cottage cheese tubs, etc.), and metal containers. Do not use paper containers (cardboard paint buckets), polystyrene (foam) containers, or any disposable drink containers.

Brushing: Use only natural bristle brushes, such as the disposable brushes sold by the home stores. Do not use foam brushes!

Rolling: CPES can be easily rolled on any flat surface. Use a solvent-resistant roller with a medium nap.

Spraying: Use high quality insecticide spray bottles/equipment or the spray bottle we sell, which has been tested for handling strong carrier solvents. When spraying the nozzle should be set to coarse spray, and a cartridge respirator should be worn to protect against inhaling the solvent fumes.

Injecting: Use our special nylon-bushing syringe, or a high quality medical or solvent syringe.

Cleaning: All brushes/equipment can be cleaned with our Epoxy Clean-up Solvent or lacquer thinner.

CPES™-Wood based epoxy products to repair and resist wood rot.

Pouring CPES™: The initial pouring of CPES™ from gallon cans can be difficult unless it is done correctly. We supply free pour spouts with all our gallon units. If you have a pour spout, do this: tilt can on broad side bottom wide edge with the opening at the top. Tip carefully with the container lip under the edge of the can opening/pour spout. CPES™ will pour freely without gurgling or splashing.

As a general purpose sealant and preservative:

We apply CPES™ generously to any exposed wood that is in an area that is subject to heat and moisture. We inject it into nooks, cracks and crannies that are exposed when prepping for painting. We apply it to the end grain of all wood, especially in corner locations. Such as into cracks between the rub rail and the hull. We use it for any nailed or screwed wood interfacings, such as decking planks to joists. We inject it into fastening holes when hardware is removed or replaced. If there is bare wood around, it gets soaked in CPES™.

ALWAYS MIX THOROUGHLY!

Improper mixing is the greatest cause of epoxy systems failure.

CPES™ is a hazardous product. Check the [shipping options](#) on the order form for details on shipping hazardous items. For additional information refer to the CPES [Material Safety Data Sheet](#).

Have fun! This stuff is true magic!

www.rotdoctor.com Wood Treatment and Preservation Products

Ordering & Support	Product Information	Using Our Epoxies	Using Our Polyurethanes	Product Testing	Wooden Boats	Fiberglass Boats	Homes	Log Homes	Doc's Q & A
Product Line & Price List		Product MSDS		Application Guide					

The Rot Doctor, Inc.
P.O. Box 30612 • Seattle, WA 98113
Voice: 206.364.2155 • Fax: 206.364.4744
E-mail: drrot@rotdoctor.com

Order by phone, fax, mail, or e-mail.

© 1997-2014 The Rot Doctor, Inc.

Most products ship same day from both coasts!
Our business hours are 6:30 AM to 5:30 PM Pacific Time, Monday-Friday.
Tech support is available over weekends.

<http://www.rotdoctor.com/products/cpes.html>[5/8/2014 5:11:10 AM]

Appendix I: Triton Trimol 36 Technical Specifications



Triton TRIMOL 36 STRUCTURAL GROUT

Description

Triton TRIMOL 36 is a three component, pourable epoxy resin system for use as a structural grout. The resin is of a light golden colour which is mixed in the ratio of 100 parts by weight (p.b.w) with 20 p.b.w of the hardener - an almost colourless liquid - to provide a base for the addition of the filler component which consists of graded siliceous aggregates. The system is either cold or warm setting to give a structurally discreet back-fill, principally for timber repairs.

Characteristics

Triton TRIMOL 36 mixtures are, by reason of site control over filler concentration, capable of being used to provide a pourable grout or back-fill for a wide range of temperatures. The cured product creeps sufficiently under loading to accommodate movement in complex timber joints.

Uses

Triton TRIMOL 36 structural grout is a versatile product for site repairs to rotten, insect or fire damaged timbers to re-make joints, breaks or shakes; the system is recommended for use with Triton TRIMOL 50 epoxy glass pultruded rods where their strength, corrosion resistance and compatibility with the epoxy grout makes them superior to mild or stainless steel reinforcement.

Trimol System

Product	Appearance	Density at 25°C
Trimol 36 Resin	Clear, pale golden colour liquid	1.14 mg/mm ³
Trimol 36 Hardener	Clear, colourless liquid	1.01 mg/mm ³

Pretreatment

Contaminated surfaces can inhibit both subsequent bonding and appearance. Remove any loose surface deposits or rotten timber: visible surfaces may be left natural or cut off to leave a clean interface between timber and synthetic repair. Prop where necessary. Shutter the repair area using melamine faced chipboard e.g. contiboard; render the pre-waxed shuttered box leakproof with the aid of one component silicone sealant and allow this to cure.

Where the pour is to be into masonry make a good seal by utilising a compatible product e.g Triton TRIMOL 54 epoxy wood, which may be used as a putty. Lay Triton TRIMOL 50 rods across any gap between either rotten timber or from timber to masonry, always ensuring that the rods are seated into good timber.

Product	Parts by weight
Trimol 36 Resin	100
Trimol 36 Hardener	20

Mixing

- Pour resin and hardener into the pail supplied and mix thoroughly with a palette knife or similar until a clear, non-striated mix is achieved.
- Add filler slowly until a pourable viscosity is reached.



Usable life

The following times hold for 20°C. In bulk an 8 Kg mix is usable for about thirty minutes. Breaking down to smaller quantities of mix will help extend the life to about forty-five minutes. The usable life at higher temperatures will be shortened.

Application

To avoid excessive build-up of exothermic heat the mixed system is poured to a depth of 50mm when working at 20°C - less at higher temperatures. Allow the system to gel before continuing in 50mm layers until completion of the fill. Strike shuttering after 12 hours at 20°C.

Curing

After 3 days at 20°C any propping may be removed; any loading may now be imposed.

Working temperature

The usable life and other published times hold for R.T.,(20°C) they will be shortened by higher temperatures.

Storage

The separate components, stored at 5°C. to 25°C in dry conditions, have shelf life of 2 years.

Cleaning Equipment

Clean before the mixture has hardened with Triton RESIN CLEANER

Physical Properties

STRUCTURAL GROUT		
Usable Life of 5kg	At 20°C	30 min
	At 5°C	90 min
Gel time	At 20°C	8 hours
	At 5°C	36 hours
Specific Gravity	At 20°C	1.8

Mechanical properties after curing 21 days 20°C
Test temperature: 20°C



CRACK INJECTION SYSTEM - FILLED		
Tensile strength ISO/R.527	MPa	30
Tensile modulus ISO/R.527	Gpa	-
Elongation at break ISO/R.527	%	1
Flexural strength* ISO 178	MPa	40
Flexural modulus ISO 178	Gpa	-
Compressive strength* ISO 604	MPa	110
Coefficient of expansion ASTM D696	Linear/°C	-

Health & Safety

For full information consult the relevant Material Safety Data Sheet.

For further information please contact:

Triton Chemical Manufacturing Co Ltd T/a Triton Systems

Units 3 – 5 Crayford Commercial Centre, Greyhound Way, Crayford, Kent DA1 4HF

Tel: 01322 318830

Fax: 01322 524017

Email: info@tritonsystems.co.uk

www.tritonsystems.co.uk

Ref: Triton Triton 95 07/11

Appendix J: West System 105/205 Technical Specifications



Technical Data Sheet

105 System

105/205

105 Epoxy Resin® / 205 Fast Hardener®

General description

105/205 Epoxy is used for general coating and bonding applications at lower temperatures and to produce a rapid cure that develops its physical properties quickly at room temperature.

105/205 forms a high-strength, moisture-resistant solid with excellent bonding and barrier coating properties. It will wet out and bond to wood fiber, fiberglass, reinforcing fabrics, foam and other composite materials, and a variety of metals.

105/205 Epoxy can be thickened with WEST SYSTEM fillers to bridge gaps and fill voids and can be sanded and shaped when cured. With roller applications, it has excellent thin-film characteristics, allowing it to flow out and self-level without "fish-eyeing." Multiple coats of 105/205 Epoxy create a superior moisture barrier and a tough, stable base for paints and varnishes. It is formulated without volatile solvents resulting in a very low VOC content. It has a relatively high flash point, no strong solvent odor and does not shrink after curing. It is not intended for clear coating natural finished wood.

Handling characteristics

Mix ratio by volume (300 Mini Pump ratio)	5 parts resin : 1 part hardener
by weight	5.19 : 1
Acceptable ratio range by weight	4.84 : 1 to 6.20 : 1
Mix viscosity (at 72°F) ASTM D-2393	975 cps
Pot life (100g at 72°F)	9 to 12 minutes
Working time, thin film*	60 to 70 minutes
Cure to a solid, thin film*	6 to 8 hours
Cure to working strength	1 to 4 days
Minimum recommended temperature	40°F (4°C)

*Epoxy cures faster at higher temperatures and in thicker applications.

Physical properties of cured epoxy

Specific gravity	1.18
Hardness (Shore D) ASTM D-2240	83
Compression yield ASTM D-695	11,400 psi
Tensile strength ASTM D638	7,900 psi
Tensile elongation ASTM D-638	3.4%
Tensile modulus ASTM D-638	4.08E+05
Flexural strength ASTM D-790	14,100 psi
Flexural modulus ASTM D-790	4.61E+05
Heat deflection temperature ASTM D-648	118°F
Onset of T _g by DSC	129°F
Ultimate T _g	142°F
Annular shear fatigue @ 100,000 cycles	10,600 lb

Storage/Shelf life

Store at room temperature. Keep containers closed to prevent contamination. With proper storage, resin and hardeners should remain usable for many years. After a long storage, verify the metering accuracy of the pumps. Mix a small test batch to assure proper curing.

Over time, 105 Resin will thicken slightly and will therefore require extra care when mixing. Repeated freeze/thaw cycles during storage may cause crystallization of 105 Resin. Warm resin to 125°F and stir to dissolve crystals. Hardener may darken with age, but physical properties are not affected by color. Be aware of a possible color shift if very old and new hardener are used on the same project.

Manufactured for
WEST SYSTEM by:



Gougeon Brothers Inc.
P.O. Box 908
Bay City, MI 48707

866-937-8797

www.westsystem.com

March, 2013

Index

Abstention	20, 22, 23
Acceleration.....	20, 23
American chestnut.....	18, 31, 59, 61, 67, 81
authenticity	21, 22, 26
BETA system	29, 31
bond strength	13, 16, 56, 65, 66, 77
Cellulose	32, 33
Circumvention	20, 23
coefficient of thermal expansion.....	40
compatibility.....	6, 9, 18, 31, 44, 48, 52, 56, 57, 58, 61, 63, 67, 70, 72, 73, 74, 75, 76, 77, 80, 81, 82
Consolidant.....	4, 5, 14, 26, 73
consolidation	9
<i>Cure Time</i>	49
durability	9, 14, 16, 17, 18, 19, 21, 22, 34, 47, 57, 62, 64, 73, 75, 77, 80
<i>epoxide</i>	46
Epoxy repairs	9, 12, 20, 23
gap-filling structural adhesive	9
glass transition temperature	See heat deflection temperature
grain angle	65, 66, 67, 76
heat deflection temperature	49
hemicellulose.....	32, 33, 34
International Council on Monuments and Sites	22
lignin.....	9, 10, 33, 34
mechanical properties	
tensile, compressive, shear, flexural.....	10, 11, 27, 31, 32, 34, 40, 42, 50, 52, 75, 77, 79
Mitigation	20, 23
modulus of elasticity	25, 35, 39, 51
moisture content	15, 16, 31, 40, 41, 42, 63, 65, 69, 70, 76, 78, 81
porosity	58, 63, 73, 74, 75, 82
Pot life	49
Reconstitution	20, 23
relative humidity.....	20, 48, 63, 79
Resin Bonded Timber Repair	11, 25, 83
reversibility.....	14, 16, 21, 22, 75
shear modulus	35, 39, 47
southern yellow pine	18, 31, 58, 61
Specific Gravity	40
structural adhesive	9
Structural Gap-Filling Adhesive	4, 5, 15, 28, 67, 78
structural timber elements	18, 19
Substitution	20, 23
surface properties of a wood	42
Viscosity	48
W.E.R. system	24, 29
white oak.....	18, 31, 59, 61, 67, 69, 78, 81, 82

wood cell	6, 32, 33, 34, 65, 73, 74, 76, 80
wood structure	57, 58