

Notice to installing contractor: Instructions must remain with installation.

"QUALITY PUMPS SINCE 1939"

SECTION: 6.10.001

FM0447

Rev. A

1009

Supersedes

0809

Product information presented here reflects conditions at time of publication. Consult factory regarding discrepancies or inconsistencies.

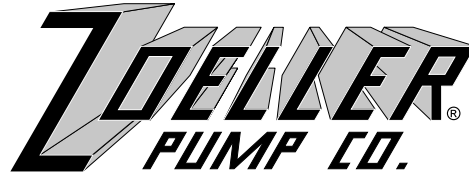

MAIL TO: P.O. BOX 16347 • Louisville, KY 40256-0347
 SHIP TO: 3649 Cane Run Road • Louisville, KY 40211-1961
 (502) 778-2731 • 1 (800) 928-PUMP • FAX (502) 774-3624

visit our web site:
www.zoeller.com

NOTICE: VENT HOLE FOR CHECK VALVE SEE #3 IN CAUTION SECTION BELOW AND #4 ON PAGE 3

INSTALLATION INSTRUCTIONS RECOMMENDED MODELS

DATE INSTALLED:
MODEL NUMBER:



EFFLUENT*/SUMP/DEWATERING	SEWAGE
49, 50 Series, 70 Series, 98 Series	211 Series, 264 Series
130 Series, 140/4140, 145/4145 Series, 150 Series, 160/4160 Series	260 Series, 270/4270 Series
180/4180 Series, 191, 371, 372, 373	280/4280 Series, 290/4290 Series

P/N 006355

*Effluent systems should specify that pumps should not handle solids exceeding three fourths inch (¾") in order to prevent large solids from entering leeching fields, mound systems etc. (Model 49 and 70 Series have 3/8" solids capability, 50, 90, 140, 145/4145, 151, 371 and 372 Series have ½", 130 Series has 5/8", 152, 153, and 160/4160/180/4180, 373 Series have ¾".) Where codes permit, sewage pumps can be used for effluent systems. Nonautomatic pump(s) with external level control recommended for septic tank effluent applications.

PREINSTALLATION CHECKLIST - ALL INSTALLATIONS

1. **Inspect your pump.** Occasionally, products are damaged during shipment. If the unit is damaged, contact your dealer before using. **DO NOT** remove the test plugs in the cover nor the motor housing.
2. **Carefully read the literature** provided to familiarize yourself with specific details regarding installation and use. These materials should be retained for future reference.

 WARNING SEE BELOW FOR LIST OF WARNINGS	 CAUTION SEE BELOW FOR LIST OF CAUTIONS
<ol style="list-style-type: none"> 1. Make certain that the receptacle is within the reach of the pump's power supply cord. DO NOT USE AN EXTENSION CORD. Extension cords that are too long or too light do not deliver sufficient voltage to the pump motor. But, more important, they could present a safety hazard if the insulation were to become damaged or the connection end were to fall into the sump. 2. Make sure the pump electrical supply circuit is equipped with fuses or circuit breakers of proper capacity. A separate branch circuit is recommended, sized according to the "National Electrical Code" for the current shown on the pump nameplate. 3. Testing for ground. As a safety measure, each electrical outlet should be checked for ground using an Underwriters Laboratory Listed circuit analyzer which will indicate if the power, neutral and ground wires are correctly connected to your outlet. If they are not, call a qualified licensed electrician. 4. For Added Safety. Pumping and other equipment with a 3-prong grounded plug must be connected to a 3-prong grounded receptacle. For added safety the receptacle may be protected with a ground-fault circuit interrupter. When a pump needs to be connected in a watertight junction box, the plug can be removed and spliced to the supply cable with proper grounding. For added safety this circuit may be protected by a ground-fault circuit interrupter. The complete installation must comply with the National Electrical Code and all applicable local codes and ordinances. 5. FOR YOUR PROTECTION, ALWAYS DISCONNECT PUMP FROM ITS POWER SOURCE BEFORE HANDLING. Single phase pumps are supplied with a 3-prong grounded plug to help protect you against the possibility of electrical shock. DO NOT UNDER ANY CIRCUMSTANCES REMOVE THE GROUND PIN. The 3-prong plug must be inserted into a mating 3-prong grounded receptacle. If the installation does not have such a receptacle, it must be changed to the proper type, wired and grounded in accordance with the National Electrical Code and all applicable local codes and ordinances. Three phase pumps require motor starting devices with motor overload protection. See FM0486 for duplex installations. 6. The tank is to be vented in accordance with local plumbing code. Pumps must be installed in accordance with the National Electrical Code and all applicable local codes and ordinances. Pumps are not to be installed in locations classified as hazardous in accordance with National Electrical Code, ANSI/NFPA 70. 7. "Risk of electrical shock" Do not remove power supply cord and strain relief or connect conduit directly to the pump. 8. Installation and servicing of electrical circuits and hardware should be performed by a qualified licensed electrician. 9. Pump installation and servicing should be performed by a qualified person. 10. Risk of electric shock - These pumps have not been investigated for use in swimming pool and marine areas. 11. According to the state of California (Prop 65), this product contains chemicals known to the state of California to cause cancer and birth defects or other reproductive harm. 	<ol style="list-style-type: none"> 1. Check to be sure your power source is capable of handling the voltage requirements of the motor, as indicated on the pump name plate. 2. The installation of automatic pumps with variable level float switches or nonautomatic pumps using auxiliary variable level float switches is the responsibility of the installing party and care should be taken that the tethered float switch will not hang up on the pump apparatus or pit peculiarities and is secured so that the pump will shut off. It is recommended to use rigid piping and fittings and the pit be 18" or larger in diameter. 3. Information - vent hole purpose. It is necessary that all submersible sump, effluent, and sewage pumps capable of handling various sizes of solid waste be of the bottom intake design to reduce clogging and seal failures. If a check valve is incorporated in the installation, a vent hole (approx. 3/16") must be drilled in the discharge pipe below the check valve and pit cover to purge the unit of trapped air. Trapped air is caused by agitation and/or a dry basin. Vent hole should be checked periodically for clogging. The 50 or 90 Series pumps have a vent located in the pump housing opposite the float, adjacent to a housing lug, but an additional vent hole is recommended. The vent hole on a High Head application may cause too much turbulence. You may not want to drill one. If you choose not to drill a vent hole, be sure the pump case and impeller is covered with liquid before connecting the pipe to the check valve and no inlet carries air to the pump intake. NOTE: THE HOLE MUST ALSO BE BELOW THE BASIN COVER AND CLEANED PERIODICALLY. Water stream will be visible from this hole during pump run periods. 4. Pump should be checked frequently for debris and/or build up which may interfere with the float "on" or "off" position. Repair and service should be performed by Zoeller Pump Company Authorized Service Station only. 5. Dewatering and effluent sump pumps are not designed for use in pits handling raw sewage. 6. Maximum operating temperature for standard model pumps must not exceed 130°F (54°C). Model 49 max. temperature must not exceed 104°F (40°C). The 70 and 211 Series max. temperature must not exceed 110°F (43°C). 7. Pump models 188/4188, 189/4189, and 295/4295 nonautomatic pump must run totally submerged and CSA certified pumps must be operated submerged with "off - on" level controls. 8. Pump models 266, 267, 268, 137 and 139 must be operated in an upright position. Do not attempt to start pump when tilted or laying on its side. 9. Do not operate a pump in an application where the Total Dynamic Head is less than the minimum Total Dynamic Head listed on the Pump Performance Curves. 10. Model 49 is for indoor use only. <p>NOTE: Pumps with the "UL" mark and pumps with the "US" mark are tested to UL Standard UL778. CSA Certified pumps are certified to CSA Standard C22.2 No. 108.</p>

REFER TO WARRANTY ON PAGE 2.

Limited Warranty

Manufacturer warrants, to the purchaser and subsequent owner during the warranty period, every new product to be free from defects in material and workmanship under normal use and service, when properly used and maintained, for a period of one year from date of purchase by the end user, or 18 months from date of original manufacture of the product, whichever comes first. Parts that fail within the warranty period, one year from date of purchase by the end user, or 18 months from the date of original manufacture of the product, whichever comes first, that inspections determine to be defective in material or workmanship, will be repaired, replaced or remanufactured at Manufacturer's option, provided however, that by so doing we will not be obligated to replace an entire assembly, the entire mechanism or the complete unit. No allowance will be made for shipping charges, damages, labor or other charges that may occur due to product failure, repair or replacement.

This warranty does not apply to and there shall be no warranty for any material or product that has been disassembled without prior approval of Manufacturer, subjected to misuse, misapplication, neglect, alteration, accident or act of God; that has not been installed, operated or maintained in accordance with Manufacturer's installation instructions; that has been exposed to outside substances including but not limited to the following: sand, gravel, cement, mud, tar, hydrocarbons, hydrocarbon derivatives (oil, gasoline, solvents, etc.), or other abrasive or corrosive substances, wash towels or feminine sanitary products, etc. in all pumping applications. The warranty set out

in the paragraph above is in lieu of all other warranties expressed or implied; and we do not authorize any representative or other person to assume for us any other liability in connection with our products.

Contact Manufacturer at, 3649 Cane Run Road, Louisville, Kentucky 40211, Attention: Customer Service Department to obtain any needed repair or replacement of part(s) or additional information pertaining to our warranty.

MANUFACTURER EXPRESSLY DISCLAIMS LIABILITY FOR SPECIAL, CONSEQUENTIAL OR INCIDENTAL DAMAGES OR BREACH OF EXPRESSED OR IMPLIED WARRANTY; AND ANY IMPLIED WARRANTY OF FITNESS FOR A PARTICULAR PURPOSE AND OF MERCHANTABILITY SHALL BE LIMITED TO THE DURATION OF THE EXPRESSED WARRANTY.

Some states do not allow limitations on the duration of an implied warranty, so the above limitation may not apply to you. Some states do not allow the exclusion or limitation of incidental or consequential damages, so the above limitation or exclusion may not apply to you.

This warranty gives you specific legal rights and you may also have other rights which vary from state to state.

In those instances where damages are incurred as a result of an alleged pump failure, the Homeowner must retain possession of the pump for investigation purposes.

EASY DO'S & DON'T'S FOR INSTALLING A SUMP PUMP

1. **DO** read thoroughly all installation material provided with the pump.
2. **DO** inspect pump for any visible damage caused by shipping. Contact dealer if pump appears to be damaged.
3. **DO** clean all debris from the sump. Be sure that the pump will have a hard, flat surface beneath it. **DO NOT** install on sand, gravel or dirt.
4. **DO** be sure that the sump is large enough to allow proper clearance for the level control switch(es) to operate properly.
5. **DO Always Disconnect Pump From Power Source Before Handling.** **DO** always connect to a separately protected and properly grounded circuit. **DO NOT** ever cut, splice, or damage power cord (Only splice in a watertight junction box). **DO NOT** carry or lift pump by its power cord. **DO NOT** use an extension cord with a sump pump.
6. **DO** install a check valve and a union in the discharge line. **DO NOT** use a discharge pipe smaller than the pump discharge.
7. **DO NOT** use a sump pump as a trench or excavation pump, or for pumping sewage, gasoline, or other hazardous liquids.
8. **DO** test pump immediately after installation to be sure that the system is working properly.
9. **DO** cover sump with an adequate sump cover.
10. **DO** review all applicable local and national codes and verify that the installation conforms to each of them.
11. **DO** consult manufacturer for clarifications or questions.
12. **DO** consider a two pump system with an alarm where an installation may become overloaded or primary pump failure would result in property damages.
13. **DO** consider a D.C. Backup System where a sump or dewatering pump is necessary for the prevention of property damages from flooding due to A.C. power disruptions, mechanical or electrical problems or system overloading.
14. **DO** inspect and test system for proper operations at least every three months.

SERVICE CHECKLIST



▲ WARNING **ELECTRICAL PRECAUTIONS-** Before servicing a pump, always shut off the main power breaker and then unplug the pump - making sure you are wearing insulated protective sole shoes and not standing in water. Under flooded conditions, contact your local electric company or a qualified licensed electrician for disconnecting electrical service prior to pump removal.

▲ WARNING Submersible pumps contain oils which becomes pressurized and hot under operating conditions - **allow 2½ hours after disconnecting before attempting service.**

CONDITION	COMMON CAUSES
A. Pump will not start or run.	Check fuse, low voltage, overload open, open or incorrect wiring, open switch, impeller or seal bound mechanically, defective capacitor or relay when used, motor or wiring shorted. Float assembly held down. Switch defective, damaged, or out of adjustment.
B. Motor overheats and trips overload or blows fuse.	Incorrect voltage, negative head (discharge open lower than normal) impeller or seal bound mechanically, defective capacitor or relay, motor shorted.
C. Pump starts and stops too often.	Float tight on rod, check valve stuck or none installed in long distance line, overload open, level switch(s) defective, sump pit too small.
D. Pump will not shut off.	Debris under float assembly, float or float rod bound by pit sides or other, switch defective, damaged or out of adjustment.
E. Pump operates but delivers little or no water.	Check strainer housing, discharge pipe, or if check valve is used vent hole must be clear. Discharge head exceeds pump capacity. Low or incorrect voltage. Incorrect motor rotation. Capacitor defective. Incoming water containing air or causing air to enter pumping chamber.
F. Drop in head and/or capacity after a period of use.	Increased pipe friction, clogged line or check valve. Abrasive material and adverse chemicals could possibly deteriorate impeller and pump housing. Check line. Remove base and inspect.

If the above checklist does not uncover the problem, consult the factory - Do not attempt to service or otherwise disassemble pump. Service must be performed by Zoeller Authorized Service Stations. Go to www.zoeller.com/zcopump/TechSupport/authsslisting.htm to find the Authorized Service Station in your area.

RECOMMENDED INSTALLATION FOR ALL APPLICATIONS

- (1) Electrical wiring and protection must be in accordance with National Electrical Code and any other applicable state and local electrical requirements.
 - (2) Install proper Zoeller unichek (combination union and check valve), preferably just above the basin to allow easy removal of the pump for cleaning or repair. On sewage, effluent or dewatering, if high head or below cover installation is required use 30-0164 on 1½" pipe, 30-0152 on 2" pipe and 30-0160 on 3" pipe. See (4) below.
 - (3) All installations require a basin cover to prevent debris from falling into the basin and to prevent accidental injury.
 - (4) When a Unichek is installed, drill a 3/16" dia. hole in the discharge pipe even with the top of the pump. **NOTE: THE HOLE MUST ALSO BE BELOW THE BASIN COVER AND CLEANED PERIODICALLY.** (High Head unit see #3 under "Caution" on front page). Water stream will be visible from this hole during pump run periods.
 - (5) Securely tape or clamp power cord to discharge pipe, clear of the float mechanism(s).
 - (6) Use full-size discharge pipe.
 - (7) Basin must be in accordance with applicable codes and specifications.
 - (8) Pump must be level and float mechanism(s) clear of sides of basin before starting pump.
 - (9) Basin must be clean and free of debris after installation.
 - (10) Gate Valve or Ball Valve to be supplied by installer and installed according to any and all codes.
 - (11) Locate float switches as shown in sketches. The best place for the "off" point is above the motor housing and positioned 180° from the inlet. Never put "off" point below discharge on pump (Sewage & Effluent only). **NOTE: FOR AUTOMATIC PUMPS, USE DEWATERING INSTALLATION SKETCH.**
 - (12) Gas tight seals required to contain gases and odors.
 - (13) Vent gases and odors to the atmosphere through vent pipe (Sewage & Dewatering only).
 - (14) Install Zoeller Pump Stand (Model 10-2421) under pump to provide a settling basin. (Effluent & Dewatering only).
- For Effluent Only:**
- (15) Wire pump to power through a Zoeller watertight junction box or watertight splice. **NOTE: Watertight enclosure is a must in damp areas. See No. 8 on front page of FM0732.**
 - (16) Refer to SSPMA Effluent Sizing Manual for determining "on" - "off" switches.
 - (17) Septic tank risers must be used for easy pump and filter access.
- NOTE: Double seal pumps offer extra protection from damage caused by seal failure.**

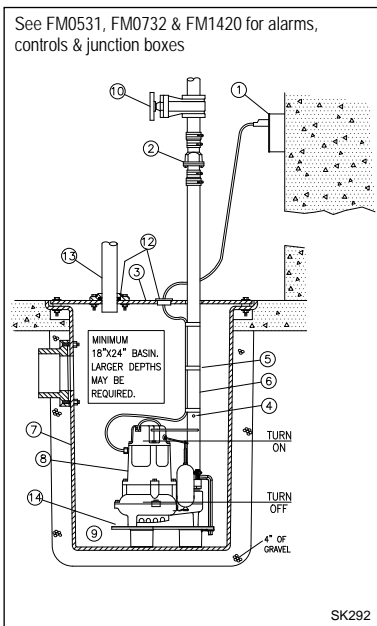

TYPICAL DEWATERING INSTALLATION

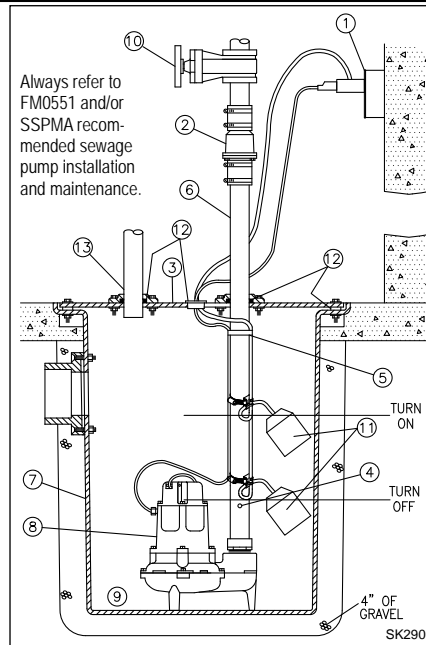

TYPICAL SEWAGE INSTALLATION

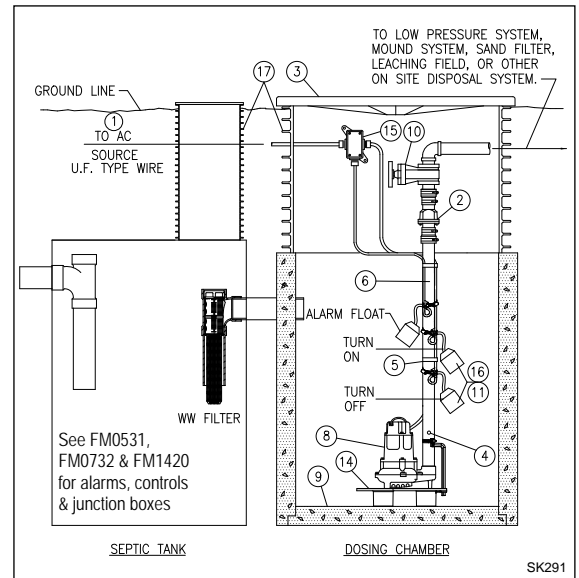

TYPICAL EFFLUENT INSTALLATION

All installations must comply with all applicable electrical and plumbing codes, including, but not limited to, National Electrical Code, local, regional, and/or state plumbing codes, etc. Not intended for use in hazardous locations.

SUGGESTED METHODS OF FLOAT INSTALLATION

On some installations it may be desirable to install an independent hanger for the level control switches to avoid possible hang ups on the pumps, piping, valves, etc. Float hangers are available from Zoeller Company on Catalog Sheet FM0526 or can be fabricated from standard pipe and fittings.

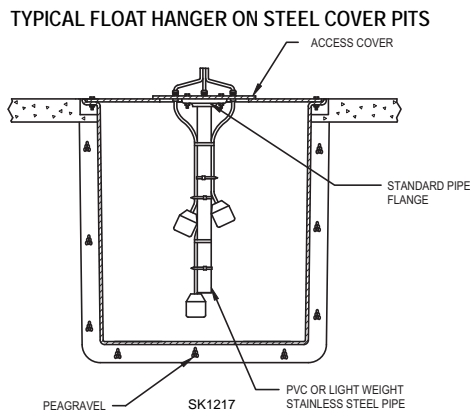

SK1217

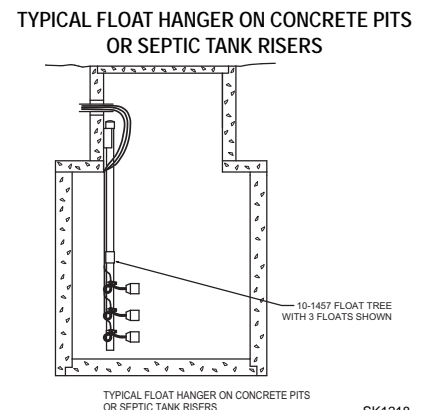

SK1218

WD & WH MODEL INSTALLATION

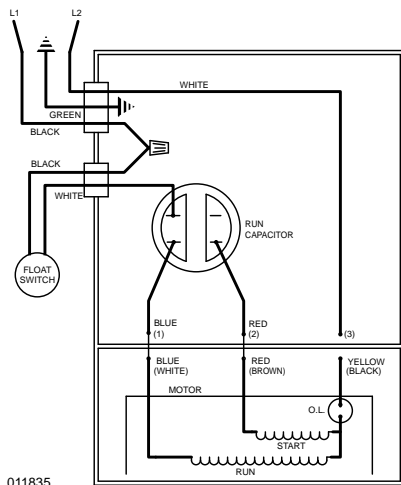

011835
WIRING DIAGRAM FOR MODELS
 WD - 230V, 1 Ph, 60 Hz.
 WH - 200/208V, 1 Ph, 60 Hz.

Determining Pumping Range in Inches (1 inch - 2.5 cm)

Tether Length	5	10	15	20	22
	min.				max.
Pumping Range	9	13.5	18	22	24

Use only as a guide. Due to weight of cable, pumping range above horizontal is not equal to pumping range below horizontal. Ranges are based on testing in nonturbulent conditions. Range may vary due to water temperature and cord shape. As tether length increases, so does the variance of the pumping range.

Models WD & WH are fully automatic. A float switch is included and factory wired in the pump circuit to provide automatic operation once the float switch is secured properly to the outlet pipe. Use the diagram above to secure the float switch properly and obtain the proper tether to customize the on-off cycle to each application.

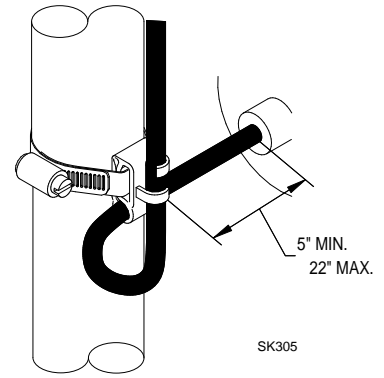

20 AMP SWITCH (WD & WH MODELS)

Note: Failure to keep within proper tether limits may prevent reliable switch operation.

Note: Cable must be mounted in horizontal position.

SINGLE PHASE WIRING INSTRUCTIONS



⚠ WARNING FOR YOUR PROTECTION, ALWAYS DISCONNECT PUMP FROM ITS POWER SOURCE BEFORE HANDLING. Single phase pumps are supplied with a 3-prong grounded plug to help protect you against the possibility of electrical shock. **DO NOT UNDER ANY CIRCUMSTANCES REMOVE THE GROUND PIN.** The 3-prong plug **must** be inserted into a mating 3-prong grounded receptacle. If the installation does not have such a receptacle, it must be changed to the proper type, wired and grounded in accordance with the National Electrical Code and all applicable local codes and ordinances.



⚠ WARNING "Risk of electrical shock" Do not remove power supply cord and strain relief or connect conduit directly to the pump.
⚠ WARNING Installation and checking of electrical circuits and hardware should be performed by a qualified licensed electrician.
⚠ WARNING Units supplied without a plug (single and three phase) and single phase nonautomatic units with a 20 amp plug must have a motor control and liquid level control provided at time of installation. The control device should have suitable voltage, ampere, frequency, grounding and horsepower rating for the pump to which it is connected.

THREE PHASE WIRING INSTRUCTIONS



⚠ WARNING FOR YOUR PROTECTION, ALWAYS DISCONNECT PUMP FROM ITS POWER SOURCE BEFORE HANDLING.

To automatically operate a nonautomatic three phase pump, a control panel is required. Follow the instructions provided with the panel to wire the system. For automatic three phase pumps see automatic 3 phase wiring diagram located to the far right.

Before installing a pump, check the pump rotation to ensure that wiring has been connected properly to power source, and that the green lead of power cord (See wiring diagram), is connected to a valid ground. Momentarily energize the pump, observing the directions of kick back due to starting torque. Rotation is correct if kick back is in the opposite direction of rotation arrow on the pump casing. If rotation is not correct, switching of any two power leads other than ground, should provide the proper rotation.

All three phase pumps require motor starting devices with motor overload protection. See FM0486 for duplex installations. Pumps **must** be installed in accordance with the National Electrical Code and all applicable local codes and ordinances. Pumps are not to be installed in locations classified as hazardous in accordance with National Electrical Code, ANSI/NFPA 70.

NONAUTOMATIC 3 PHASE

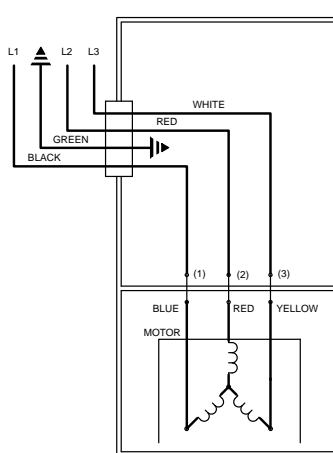

006848

AUTOMATIC 3 PHASE

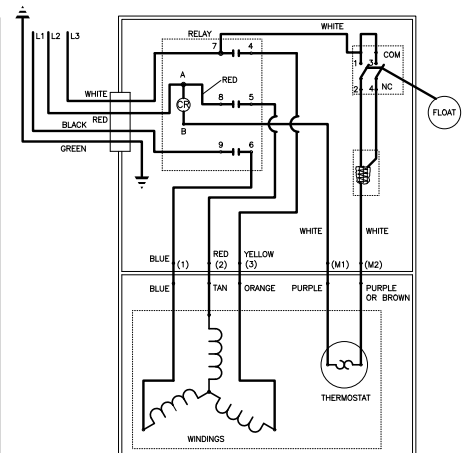

013071

IMPORTANT NOTICE: Some insurance policies, both commercial and residential, extend coverage for damages incurred by product failure. You will need to have possession of the product to support your claim in most cases. Zoeller Pump Co. will exchange the unit or refund the original purchase price once the claim is settled with the insurer in the case where you need to retain possession of the product to support a damage claim you submit to your insurance company.