

Homeowner's Guide

for Maintenance and Care of On-Site Sewage Systems

It's Your Septic System

Here's How to Take Care of It



Properly maintaining your septic system will help reduce the possibility of health risks and ensure the quality of the environment. This homeowner's guide is intended to assist you with the responsibility of keeping your system operating properly.

Components of Your On-Site Sewage Disposal System

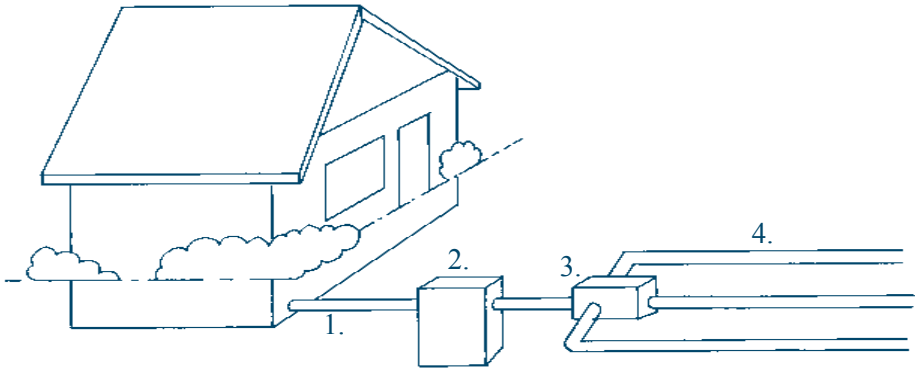

1. Conveyance or piping
2. Septic tank
3. Distribution/retention
4. Drainfields/lateral lines

Figure A

On-Site Treatment Systems Explained

On-site sewage disposal systems, more commonly known as septic systems, are individually owned and operated wastewater treatment systems which treat the wastewater from homes or small commercial facilities. They are typically used in rural areas where large lots are common and community or public wastewater treatment facilities are not available or are impractical.

While there are several types of septic systems available today, all are designed using the same standards including consideration of such factors as projected water usage, how well the soil absorbs water (permeability), location of groundwater and the slope of each proposed location. Water consumption is critical since all septic systems are designed to treat specific and limited quantities of water. All of these factors must be considered in order to ensure trouble free operation of your septic system. It should be noted that, even with the best design, septic systems will not last forever and will need repair and/or replacement some time in the future.

How does my Septic System Work?

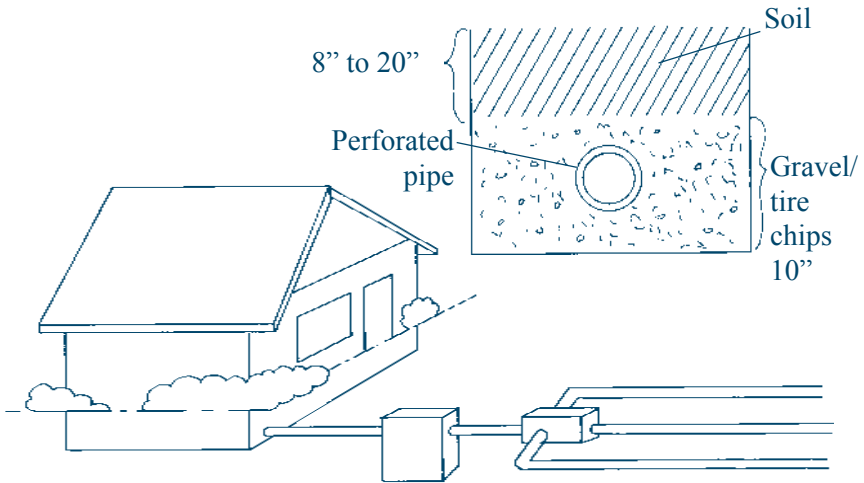

Figure B

Figures A and B illustrate the parts of your septic system and will help you to understand how your system works.

Your septic system treats the wastewater from your home or business by using a two-step treatment process. In the first step, the wastewater, along with all solid material, flows from your house into a septic tank where it is retained for various amounts of time depending on how much wastewater is flowing to the tank. While the wastewater is being held in the septic tank, the heavier solids settle to the bottom of the tank and the lighter solids rise to form a scum on the surface of the liquid. The solid layer in the bottom of the tank and the scum on the surface of the liquid remain in the tank and are both partially broken down by bacteria.

The second step begins as the partially treated wastewater flows from the septic tank into the drainfield or lateral field. The drainfield or lateral field is made up of distribution or retention boxes and perforated pipes that are surrounded by gravel and buried in trenches. The first structure that the wastewater encounters is the distribution or retention box. These boxes are designed to evenly distribute the wastewater among the lateral lines. The wastewater then flows from the distribution boxes into the lateral lines and is allowed to leak into the surrounding gravel through holes in the bottom and on the sides of the pipe. As the wastewater then moves through the gravel, it comes in contact with the

Continued on next page

soil and is absorbed. Some of the water is used by grasses growing on the surface on top of the lateral field. When the wastewater is used by plants or is absorbed by the soil, the second treatment step is completed. A properly designed and properly operating system will not pollute groundwater or allow sewage to pool on the surface, where it can present a health hazard.

More About Drainfields or Lateral Lines

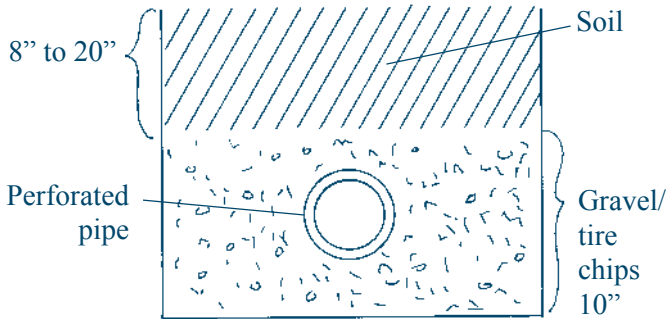

Figure C

Figure C provides additional details about the construction of lateral lines.

As previously mentioned, a drainfield is made up of distribution boxes and a network of trenches that contain lateral lines. The total depth of the trenches are 18" to 30" deep. Each of the lateral lines contains a pipe perforated with holes in the bottom and on the sides of the pipe. The perforated pipe is surrounded by gravel or some other equally porous material. The length of lateral line is primarily determined by how well the soil absorbs water. As we all know, sandy soils absorb water at a faster rate than clay type soils. Therefore, more lateral lines will be required to treat wastewater in clay soils.

It is important to remember that all septic systems are designed to treat a specific amount of wastewater. The type of soil where your lateral lines are located and the amount of water that you will use are the two most important factors in predicting how well and for how long your septic system will function. Water conservation is the most important thing you can do to ensure good service and a long life from your septic system.

Maintenance and Care of Your Septic Tank

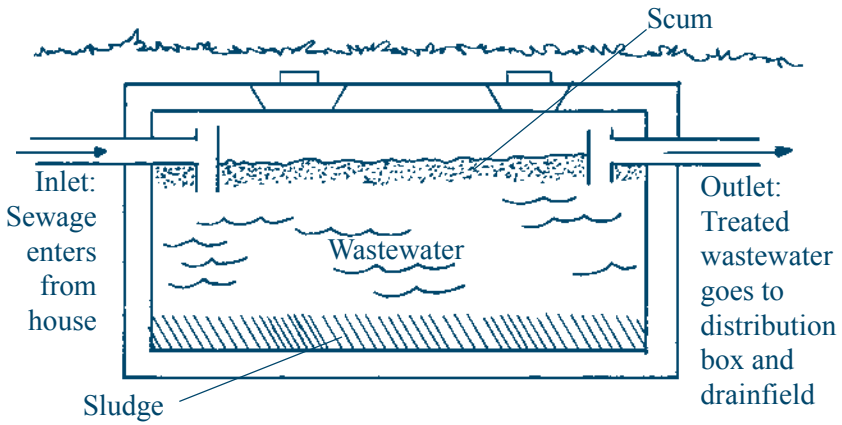

Figure D

Figures D and E will help you to better familiarize yourself with your septic system as you consider the care and maintenance of the septic tank.

Earlier, we said that the most important step you can take to take care of your septic system is to conserve water. Repairing all dripping/leaking faucets and toilets is often the best way to decrease water usage. However, running dishwashers and washing machines only when you have a full load is another way to save water. Avoiding long showers and using water saving devices on faucets, showers and toilets are also good ways to save water and extend the life of your system. The next most important thing you can do to help your septic system operate properly is to have your septic tank cleaned out, when necessary. As the heavy solids that are contained in wastewater settle out and are partially decomposed, a sludge begins to build up on the bottom of the tank. If not removed, this sludge will continue to accumulate and will eventually cause a malfunction. Under average conditions, you should have your septic tank pumped every three to five years. However, a number of factors impact the frequency of pumping. Heavy usage of a garbage disposal or the use of plastic materials or heavy paper materials can dramatically increase the amount of sludge and therefore, the frequency of pumping. Additionally, the use of harsh chemicals such as cleaning fluids, pesticides, petroleum products or drain cleaners can kill the bacteria that are breaking down the solid materials in your septic tank. Without bacterial decomposition, sludge will build up at a faster rate and pumping will be necessary more often. Another concern that is often expressed about septic tank care is the use of additives. Properly designed and properly sized septic tanks do not require the use of septic tank additives. Even when a tank is new, it is not necessary to add anything to get the bacteria working in the tank. The naturally occurring bacteria in the wastewater is all that is needed to insure the proper operation of the septic tank.

Measuring the depth of the sludge is another good way to decide when you

Continued on next page

Maintenance and Care of Your Septic Tank

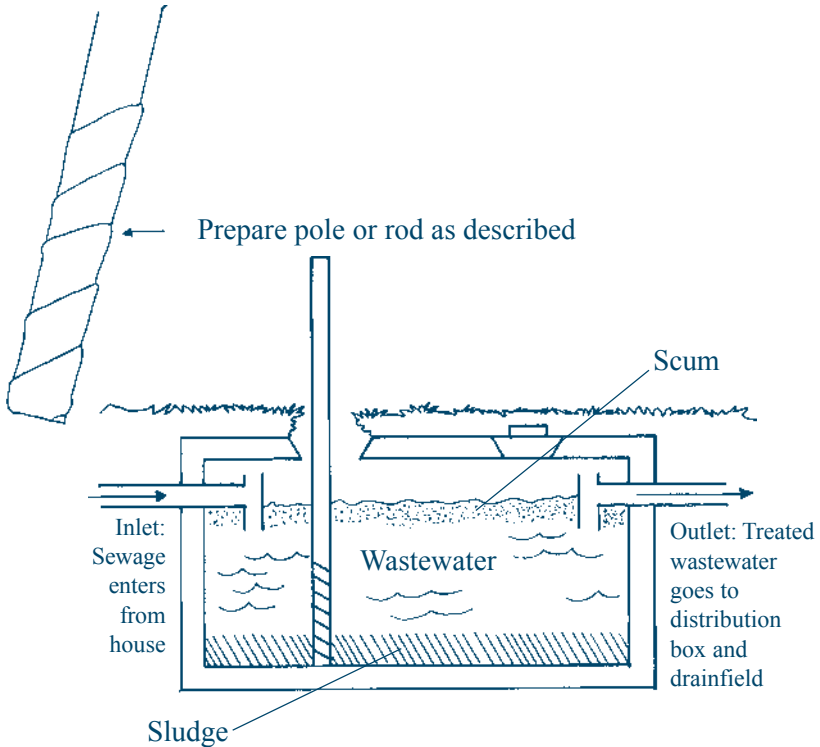

Figure E

need to have your septic tank pumped. You can measure the sludge depth yourself by using the following easy technique. Locate a pipe, rod or pole about six feet in length and cover the pole with white cotton cloth or any other white material. After you have prepared the pole, open the inspection port on the septic tank. Slowly insert the pole into the tank, taking care to keep the pole straight. Allow the pole to rest on the bottom of the tank for a couple of minutes and then slowly remove the pole. Determine the depth of the sludge by measuring the length of the darkened or stained area. Generally speaking, the tank should be pumped when the sludge depth reaches 40 percent of the tank depth or about 20 inches.

It is important to remember that having your tank pumped is one of two things you can do to help your septic system continue to function properly. Water conservation will minimize the possibility of a surfacing sewage malfunction while pumping the septic tank will keep sludge from getting into your lateral lines.

If you have questions about your septic system, you can contact your local DEQ office for assistance or information.

Tips to Avoid Trouble

DO have your tank pumped out every three to five years or as needed by a licensed contractor (septic tank pumpers are listed in the yellow pages and you should ask to see their license to insure that your waste is disposed of properly).

DO keep a record of each time you have the septic tank pumped.

DO practice water conservation. Repair all dripping/leaking faucets and toilets. Run washing machines and dishwashers only when a full load is ready to be washed. Avoid long showers and use water saving devices on faucets, shower heads and toilets.

DO divert roof drains and surface water from driveways and hillsides away from your system. This will help keep your system from becoming saturated by rain water.

DON'T allow anyone to park or drive over any part of your system. The area over the drainfield/lateral lines should be left undisturbed with only a mowed grass cover. Roots from nearby trees or shrubs clog and/or damage the lateral field.

DON'T make or allow repairs to your on-site system unless you are certain the repairs are consistent with current DEQ regulations.

DON'T do all of the laundry on the same day of the week; spread it out over a week's time. Large doses of wash water itself combined with detergents and bleaches can reduce your septic tank's performance by flooding the tank and washing out the bacteria upon which decomposition depends.

DON'T use your toilet as a trash can by dumping materials down your toilet or drains that will not be easily broken down in the septic tank. Also, do not poison your system and possibly groundwater by pouring harmful chemicals down the drain; they can kill the beneficial bacteria.

Homeowner's Guide

for Maintenance and Care of On-Site Sewage Systems

On-site sewage disposal systems are not public facilities. As a homeowner with an on-site sewage disposal system, you should always practice water conservation. If you experience problems with your system, please contact your local DEQ office for guidelines and assistance.

For more information about maintenance or construction regarding your on-site sewage disposal system, contact your local DEQ office.

Oklahoma Department of Environmental Quality Environmental Complaints and Local Services

707 N. Robinson

Oklahoma City, OK 73102

(405) 702-6100

Visit Our Web Site at:
www.deq.state.ok.us

REMEMBER, THE SINGLE MOST IMPORTANT THING YOU CAN DO
FOR YOUR SEPTIC SYSTEM IS WATER CONSERVATION.

