



Install A Hoot Don't Pollute

# HOOT SYSTEMS, LLC.

[www.hootsystems.com](http://www.hootsystems.com)

2885 Highway 14 East Lake Charles, Louisiana 70607  
(337) 474-2804 phone (337) 477-7904  
[www.hootsystems.com](http://www.hootsystems.com)

## Hoot H-Series Installers & O&M Manual

This manual covers the H-500A, H-600A, H-750A and H-1000A

This manual contains recommendations which are only suggestions. Local regulations, if more restrictive, must be followed, regardless of our recommendations. Installers must follow the design of the Designer or Professional Engineer who has designed the system for the specific application.

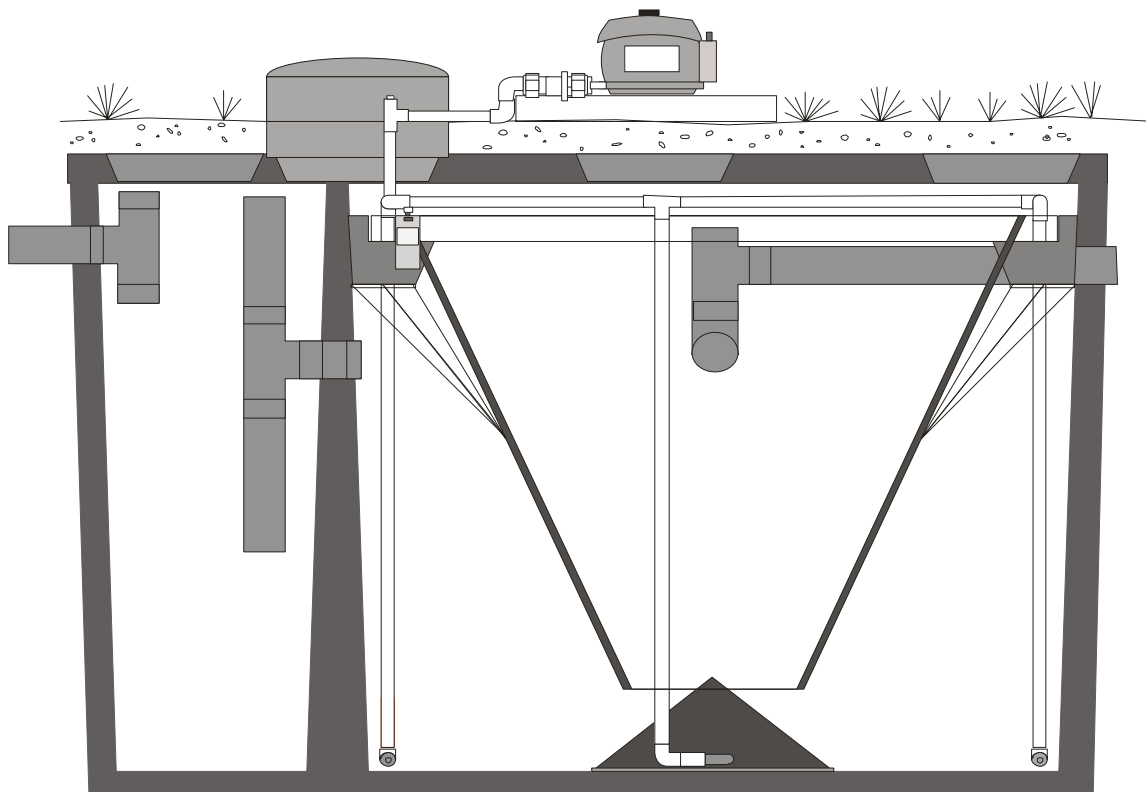

## **Declaration of Warnings**

**WARNING!** TO FUNCTION PROPERLY, THE HOOT SYSTEM MUST BE MAINTAINED BY A QUALIFIED PROFESSIONAL AT LEAST EVERY SIX (6) MONTHS FOR THE LIFE OF THE SYSTEM. FAILURE TO MAINTAIN THE HOOT SYSTEM VOIDS THE LIMITED WARRANTY AND MAY CAUSE SERIOUS BODILY INJURY OR ILLNESS TO PEOPLE AND PETS AND MAY CAUSE SERIOUS DAMAGE TO THE HOOT SYSTEM OR OTHER PROPERTY.

**DANGER!** ONLY A QUALIFIED PROFESSIONAL SHOULD ATTEMPT TO REPAIR OR FIX THE HOOT SYSTEM. ATTEMPTED REPAIR BY ANYONE OTHER THAN A QUALIFIED PROFESSIONAL MAY CAUSE SERIOUS BODILY INJURY OR DEATH TO THE HOMEOWNER OR OTHER PERSONS AND MAY CAUSE SERIOUS DAMAGE TO THE HOOT SYSTEM AND OTHER PROPERTY.

**DANGER!** DO NOT DISCONNECT THE POWER TO THE HOOT SYSTEM. DISCONNECTION OF THE POWER FROM THE SYSTEM MAY CAUSE SERIOUS ILLNESS OR DEATH TO THE HOMEOWNER AND OTHER PERSONS AND MAY CAUSE SERIOUS DAMAGE TO THE HOOT SYSTEM AND OTHER PROPERTY.

**WARNING!** IN CASE OF IMMINENT FLOOD, IMMEDIATELY TURN OFF THE ELECTRICAL POWER TO THE HOOT SYSTEM AT THE INDEPENDENT BREAKER LOCATED ON THE HOUSE. FAILURE TO TURN OFF THE ELECTRICAL POWER MAY CAUSE SERIOUS INJURY OR DEATH TO THE HOMEOWNER AND OTHER PERSONS AND MAY CAUSE SERIOUS DAMAGE TO THE HOOT SYSTEM AND OTHER PROPERTY.

**WARNING!** IF THE UNIT FAILS TO FUNCTION PROPERLY, DO NOT USE THE BATHROOM FACILITIES UNTIL QUALIFIED PERSONNEL FIX THE PROBLEM. USE OF THE BATHROOM FACILITIES DURING A SYSTEM FAILURE MAY CAUSE SERIOUS INJURY, ILLNESS, OR DEATH TO PERSONS AND MAY CAUSE SERIOUS DAMAGE TO THE HOOT SYSTEM AND OTHER PROPERTY.

**WARNING!** DO NOT ALLOW CHILDREN TO PLAY ON OR AROUND THE AEROBIC TREATMENT SYSTEM.. ALLOWING CHILDREN TO PLAY IN THESE AREAS MAY CAUSE SERIOUS BODILY INJURY, ILLNESS, OR DEATH TO THE CHILDREN AND OTHER PERSONS AND MAY CAUSE DAMAGE TO THE HOOT SYSTEM AND OTHER PROPERTY.

**DANGER!** THE BLOWER AND CONTROLLER CONTAIN NO USER SERVICABLE PARTS. DO NOT OPEN CONTROL PANEL WITHOUT ELECTRICITY DISCONTINUED AND LOCKED OUT ON THE SYSTEM. FAILURE TO DO SO COULD CAUSE SEVERE INJURY OR DEATH.

## **Recommended Prohibitions in a Hoot Aerobic System**

### **Inert Materials:**

Plastic, Rubber, Scouring Pads, Dental Floss, Cigarette Filters, Bandages, Hair, Mop Strings, Lint, Rags, Cloth and Towels do not degrade in an on-site treatment system. Inert Materials will build up solids, and lead to system malfunction, clogging or increased pump out frequency.

### **Paper Products:**

Disposable Diapers, Paper Towels, Baby Wipes, Facial Tissues, Moist Toilet Paper are not designed to dissolve in an on-site treatment system. Excessive Amounts of toilet tissue will also not decompose. All can lead to system malfunction, back-up or increased pump out frequency.

### **Food Wastes:**

Do not put Animal Fats & Bones, Grease, Coffee Grounds, Citrus & Mellon Rinds, Corn Cobs, Egg Shells, down the sink. Garbage disposal use should limited to waste that cannot be scooped out and thrown in the trash. Spoiled Dairy Products and Yeasts from home Brewery or Baking may cause excessive growth of microbes that do not degrade sewage.

### **Medicinals:**

Do not flush Baby Wipes, Lotioned or Scented Toilet tissue, Female Sanitary Products, Cotton Balls or Swabs, Condoms or expired Medicines/Antibiotics. Septic Tank additives generally do more harm than good. Automatic Disinfection Tablets (blue, clear or otherwise) will kill the organisms needed to consume waste.

### **Chemicals & Toxins:**

Can kill the microbes necessary for Treatment. Paint, Thinner, Solvents, Volatile Substances, Drain Cleaners, Automotive Fluids, Fuels, Pesticides, Herbicides, Fertilizers, Metals, Disinfectants, Sanitizers, Bleach, Mop Water, Excessive use of Household chemicals, and Backwash from Water Softener regeneration.

### **Laundry Practices:**

On-site systems must process the water as it enters the system. Laundry should be spread out over the week, not all run at one time. Excessive use of Detergents, especially those containing bleach, can affect system performance. Liquid detergents are recommended over powders. Fabric Softener sheets are recommended over liquid softeners. Bleach should be used sparingly and at half the rate indicated on the container.

### **Clear Water Waste:**

From A/C Discharge lines, Floor Drains, Gutters, Whole House Water Treatment Systems and Sump Pumps can increase the flow to your treatment system. These flows can at least disrupt, if not destroy your treatment process.

## Table of Contents

Declaration Of Warnings.....	Page 1
Items to Avoid.....	Page 2
Table of Contents.....	Page 3
HOOT Tank Diagram.....	Page 4
Tank Installation Instructions.....	Page 5
Tank Installation Checklist.....	Page 6
HOOT Trouble Shooting .....	Page 7
HOOT Operation and maintenance.....	Page 8
Stone Flush Instructions.....	Page 9 & 10
Engineering Drawings Section.....	Page 11
H-500 A.....	Page 12
H-600 A.....	Page 13
H-750 A.....	Page 14
H-750 AN.....	Page 15
H-1000 A.....	Page 16
H-1000 AN.....	Page 17
Sample Service Report.....	Page 18

# The HOOT Aerobic Treatment System Diagram

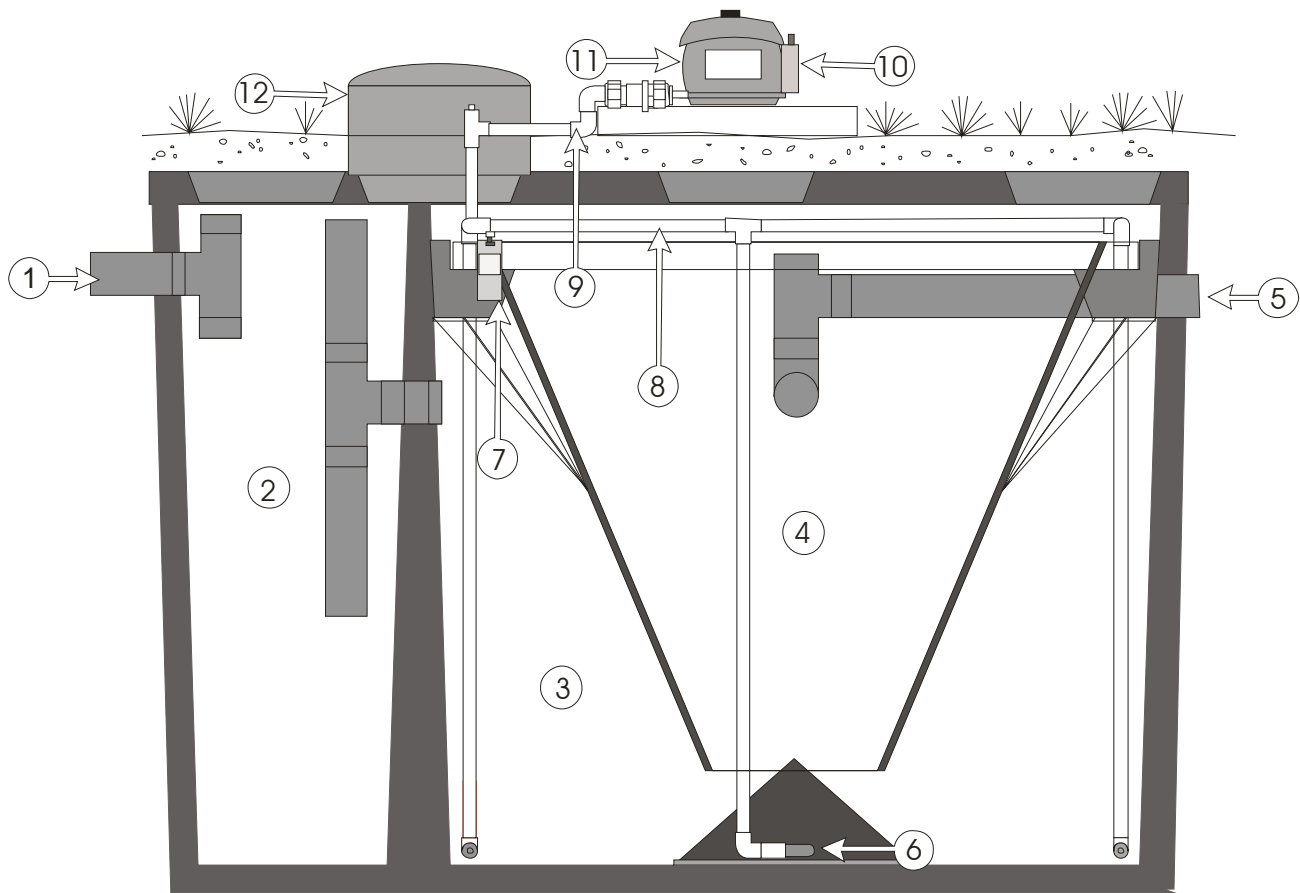

1. **Inlet:** Where sewage enters the system
2. **Pretreatment Tank:** Or Trash Trap, for Settling and Floating of non liquid waste.
3. **Aeration Chamber:** Where air is introduced to digest organic waste.
4. **Clarifier:** a still chamber where a clear, odorless, effluent rises.
5. **Outlet:** Where the treated effluent leaves the system.
6. **Diffuser:** How dissolved oxygen is added to the system.
7. **High Water Alarm:** Float that activates the high water alarm.
8. **Aeration Manifold:** How compressed air is delivered to the Diffusers.
9. **Air Line:** Delivers air to the aeration manifold and eventually the diffusers.
10. **Intergraded Alarm Panel:** Provides both High water and compressor failure alarms.
11. **Linear Air Compressor:** Provides the compressed air to operate the system.
12. **At Grade Access Riser:** Provides access to the Pre-Treatment, Aeration and Clarifier chambers for servicing and pump out.

# Tank Installation Instructions

## Tank Installation:

1. Soil cover depth: a minimum of 6" inches and no greater than 30". Systems that need to be at deeper burial should be serviced through the use of a lift station.
2. Prepare an excavation approximately one foot larger than the tank all around with a firm, level bottom. Be sure to check the depth of the excavation to the bottom of the inlet to ensure tank will be deep enough for your inlet to flow into the tank.
3. Place Tank on a level gravel bed at least 4 inches thick.
4. Fill out Hoot Installation and Delivery Tracking Form. Driver should not leave tank at job-site until this form is filled out.
5. Delivery driver will place tank in hole - and confirm it is level within 1 inch from center of tank to any corner.
6. Begin filling the tank with water to perform visual water tight integrity test.
7. Bring in 4" Schedule 40 Pipe into the inlet end of tank through one or more openings to the Pre-Treatment Tank, and Schedule 40 - 4" line out to drainfield.
8. Follow local guidance for proper backfilling of remainder of system.
9. Bring required access ports to final grade.
10. Provide power to hook up the blower/alarm system (20 Amp Service for Gravity, 30 for Pumped Effluent System)
11. Hook up blower plumbing, 1 ¼" from Blower through grommet into riser.
12. Place Blower on concrete pad, Place cover over aerator.
13. Power up system - it is ready to accept sewage.
14. Fill in Warranty Registration and Service Policy, and give to homeowner.

## **.SPECIAL INSTRUCTIONS - PLEASE NOTE!**

The depth of cover is recommended to be a minimum of 6" inches and no greater than 30". Systems that need to be at deeper burial should be serviced through the use of a lift station. Soil used for backfill should be capable of flowing, be watered in or compacted to reduce settling.

HOUSE WIRING MUST HAVE 20 AMP (30 AMP FOR PUMPED EFFLEUNT SYSTEMS) INDEPENDENT BREAKER AND MUST MEET NATIONAL - STATE - AND LOCAL REGULATIONS. INSTALLATION AND OPERATION MUST BE IN COMPLIANCE WITH STATE WATER REGULATIONS, COUNTY AND LOCAL PLUMBING AND ELECTRICAL CODES.

FAILURE TO COMPLY TO THE INSTRUCTIONS FOR THE INSTALLATION OF THE TANK AND THE SYSTEM CONTROLLER WILL VOID ANY AND ALL WARRANTIES PROVIDED BY HOOT AEROBIC SYSTEMS, INC., AND WILL PLACE THE BURDEN OF WARRANTY COVERAGE ON THE INSTALLER. FAILURE TO FOLLOW INSTALLATION INSTRUCTIONS PROPERLY MAY CAUSE SERIOUS INJURY, ILLNESS, OR DEATH TO PERSONS AND MAY CAUSE SERIOUS DAMAGE TO THE HOOT SYSTEM AND OTHER PROPERTY

# Hoot Installation Checklist

## System Information

Homeowner: \_\_\_\_\_ Home: \_\_\_\_\_  
Address: \_\_\_\_\_ Cell: \_\_\_\_\_  
City: \_\_\_\_\_ Zip: \_\_\_\_\_ e-mail: \_\_\_\_\_  
Installer: \_\_\_\_\_  
Inspector: \_\_\_\_\_  
Startup: \_\_\_\_\_  
Model Number (Top Data Plate): \_\_\_\_\_ Serial Number: \_\_\_\_\_

## Treatment System Installation

### Lines into System and Out of System

\_\_\_\_\_ Inlet Pipe into Seal (1/8" Slope), no more than 15 Degrees in any direction  
\_\_\_\_\_ Outlet Pipe into Seal (1/8" Slope), no more than 15 Degrees in any direction  
\_\_\_\_\_ 1 1/4" Airline from Blower to System

### Fill and Level

\_\_\_\_\_ Make Sure Tank is Level within 1" on Top of Aeration Chamber Portion of Tank  
\_\_\_\_\_ Is Tank Filled with Water (from Front of System to Aeration Chamber)

### Risers

\_\_\_\_\_ Risers To Grade (or Above)  
\_\_\_\_\_ Screws in each hole of each riser (Cannot Seal without them)  
\_\_\_\_\_ Lids Screwed Down (All 6 Holes)

### Blower

\_\_\_\_\_ Blower Above Finished Grade on Pad  
\_\_\_\_\_ Air Line & Pressure Connected  
\_\_\_\_\_ Cover (Dog House) over Blower  
\_\_\_\_\_ Angle "Blower Alarm" Towards Home or Driveway

### Control Panel

\_\_\_\_\_ Make sure it can be seen under Dog House  
\_\_\_\_\_ Test Alarm Switch  
\_\_\_\_\_ Test Alarm Float

# HOOT Trouble Shooting Section

## Problems at Start Up or After Power Loss

If **AERATION PROBLEM** occurs on Power up - Check Aerobic Chamber. The center tank should be full to the point where the pre-treatment tank is full and water flows into the pump tank. If it is not filled within 1 foot of the top in the Aeration tank, a **AERATION PROBLEM** will occur on start up. This occurs because there is not enough back pressure being developed, fill the tank and re-start. If there is still a problem, check air line for leaks, black line and compression fittings, check valve, and inside tank for a lose or broken diffuser line or blown out/broken stone.

## Installer Self Test - All systems

This is a simple test designed to prevent you from needing to return because of a faulty installation. As you know, you install the finest product available, to ensure you get off to a good start with the system owner, go through the following test. Failure to follow these procedures will normally result in a SYSTEM ALARM within the first 12 hours of operation.

1. Confirm that the water level in the Aeration (Center) Tank is less than 12" from the lid of the tank.
2. Power up - connect power to unit, you will hear a short beep and all the alarm light will come on for a few seconds. If the system is full with water, then this should stop and normal operation will occur.
3. Check diffuser operation over each of the openings on the aeration chamber. If air is only coming out of one opening, then there is a missing or damaged stone. If no air is coming out, confirm check valve is in the right direction, then listen for air inside tank.
4. If enough air is being supplied, and there are no leaks, then you should continue to have operation. If not, and alarm will sound.

## To Create A High Water Alarm for Inspection

To create a high water alarm for inspection purposes is a simple operation. Make sure system is on. Open the riser when the air line enters and locate the float that come in contact with the air line break. Depress up the air line break. This will release the air and create an aeration alarm.



## System Operation and Maintenance (Every 6 Months)

Every 6 months for the lifetime of the system the following need to be tested on each system.

**Check Blower**—The blower must be checked for proper operation, confirm that it is not running hot. Remove cover and clean the air filter by knocking off debris, then rinse with water, re-install. If blower is hot, check back pressure. If the back pressure in water column inches is greater than 100, then a **Stone Flush** is needed to bring the system back into performance range of :

60-70 for 500/600 GPD Systems

70-80 for 750 GPD Systems

75-90 for 1000 GPD Systems

(Items Needed: Pressure gauge that measures in water column inches.)

**Solids In Aeration Chamber**—Take sample using sludge judge from the aeration chamber while the blower is operating. Look at column as you withdraw it from the chamber. There should be a consistent color throughout the column. If it is not, and there are stratifications within the column there is a problem. Deliver the effluent to a graduated cylinder or a clear glass or jar. Let settle for 15 minutes. If the percentage of solids is more than 70% after 15 minutes, the tank should be pumped to reduce the potential for solids carry over. (Items Needed: Sludge Judge, Graduated Cylinder or glass jar or bottle)

**Pump Tank Observation and Maintenance** is the most important part of your service visit. It can tell you in just a few seconds more information than any other part of the treatment system.

**Water Quality and Clarity** An observation of the water quality should be made upon arrival to the system. Pay attention to the time of day. Is it first thing in the morning and the pump tank is near the high point in the pump tank? Is there a constant stream of water into the system and no one appears to be home? A properly functioning system should have a non-offensive odor, normally described as musty

**Solids Carry over** observe the D-box for solids carry over. Floating debris is an indication of a system that may need to be pumped out, but further testing of the settleable solids level in the aeration chamber is the only way to tell for sure- See Above If the settleable solids level is within an acceptable range (below 70% after 15 minutes) then carry over can be for a multitude of other reasons, among these are: Surge flows into the system (from garden/Jacuzzi tubs or heavy washing days)

# Stone Flush Instructions

All Aerobic systems use microorganisms, present in human sewage, to degrade household waste. There are two types of systems, Fixed Media, and Suspended Growth. Fixed Media Systems have surfaces for the bacteria to grow on and the water either flows over or through them to break down the sewage. Suspended Growth systems, have the growth suspended in the tank, and the mixing process keeps it agitated. What none of us in the industry were aware of until recently was that all suspended growth systems start off as fixed media. The growth takes place on the walls of the tank, the hopper, drop lines, etc until there is so much on the walls that it can no longer hold on. Once it begins to "sluff off" the sewage acts as an abrasive and causes it to all go into suspension and clear off of the walls of the tank.

Systems that are underused can take a long time to develop enough flock to go into suspension. Also, systems with little to no use, can grow algae, that will grow into its only available food source, the oxygen being provided by the aerator. This problem is worsened by high water temperatures. Systems with little or no cover will be more susceptible to the heat.

The Dead Head alarm goes off on our system when the pressure reaches 160 Water Column Inches in the tank. This indicates an air flow into the system so compromised that the system will fail to treat the sewage and turn septic. A properly functioning system should run between 56 and 65 for a 500 GPD system and 70 and 80 for a 1000 GPD. To read out the air pressure, put the system into the 3<sup>rd</sup> Beep mode (described in the Flash Codes Handout.) To enter this mode, restart the controller by depressing the Silence Alarm button for 16 seconds, release after the double beep and press again. Continue to hold and you will hear a single beep, followed 8 seconds later by one chirp, then two chirps, then three chirps release the switch. The controller will turn on the aeration problem lamp to indicate the air pressure test mode and chirp/flash the air pressure in inches of water. For example 65in/water 6 chirps pause 5 chirps long pause repeat. A zero is indicated by a beep instead of a chirp. For example 102in/water 1 chirp pause 1 beep pause 2 chirps long pause repeat. Ignore the first reading, it is inaccurate. If the pressure exceeds 100, then it is recommended to clean the stones to reduce the back pressure to the system. It will be necessary to use a Water Column Inch gauge if this is an old style controller.

In the past, the only way to reduce the pressure on the system was to change out the stones on the system. We have developed a method of cleaning the stones out, that is as effective as replacing the stones, and can be done from the top of the tank. The entire procedure will take less than 10 minutes and can be done during a regular scheduled service visit, particularly in the spring (before the hot weather) on under used systems.

You need to make a solution that will cleanse all of the stones, so it is necessary to pour a large volume of solution down the aeration tubing all at once. A solution can be made in a five gallon bucket. Add 2 oz. of pH down or pH minus to 4 gallons of water. Always add the powder to the water, not water to the powder and mix.

To flush the stones it will be necessary to remove the check valve from the blower air assemble as pictured to the right. If you have a remotely mounted the system, it will be necessary to get next to the tank and cut the line right before it goes into the system. This procedure will not work if you are filling more than 4 feet of pipe outside the tank.

Slide on the funnel attachment pictured to the right. It can be made using a 1 1/4" 90, 1 foot of 1/4" pipe a 4" to 2" Reducer bushing and a 2" to 1 1/4" bushing. Pour the entire contents of the 5 gallon bucket into the funnel. When the funnel fills, wait for the level to go down, and fill again.

Prop up underneath the 90 so a trap formed is not formed. Another piece of pipe, or a shim of some type will do the trick. Empty the entire bucket into the system. Once it has completely drained into the system, re-install the check valve and power up the system, putting it into the 3<sup>rd</sup> mode - Aeration Pressure. The pressure should drop almost immediately to the 60 to 80 inch range.

Once it reaches that level, again disconnect the check valve, allowing the pipe to aging fill with water, and then re-connect the check valve and power up. This will move out any additional remaining solution.

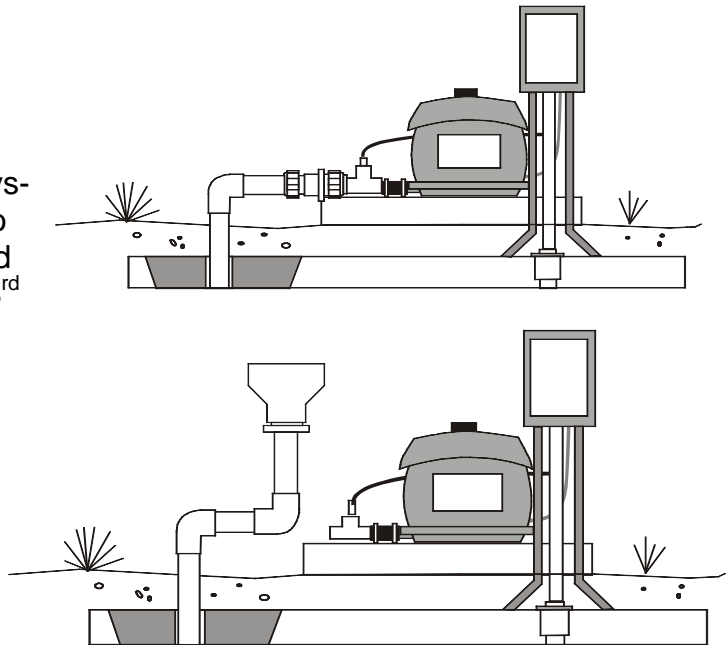

Always use caution when using chemicals of any type. Use Caution to prevent contact with skin and clothing. Eye Protection and Gloves must be used when handling the chemicals or the solution. Do not mix with any other chemicals or solutions.

hth pH Minus is available at Wal-Mart and pool supply stores. pH Down is available at Home Depot. The product should contain at least a Sodium Bisulfate content of 90%.



**HOOT SYSTEMS, LLC.**  
[www.hootsystems.com](http://www.hootsystems.com)

2885 Highway 14 East Lake Charles, Louisiana 70607  
(337) 474-2804 phone (337) 477-7904  
[www.hootsystems.com](http://www.hootsystems.com)

## Hoot H-Series Engineered Drawings

This manual covers the H-500A, H-600A, H-750A, H-750AN, H-1000A and H-1000AN

Every attempt to make the following drawings to scale has been made, however some components may have been exaggerated to show additional detail. Local regulations, if more restrictive, must be followed, regardless of our recommendations. The Designer or Professional Engineer must follow any local rules when designing a system.

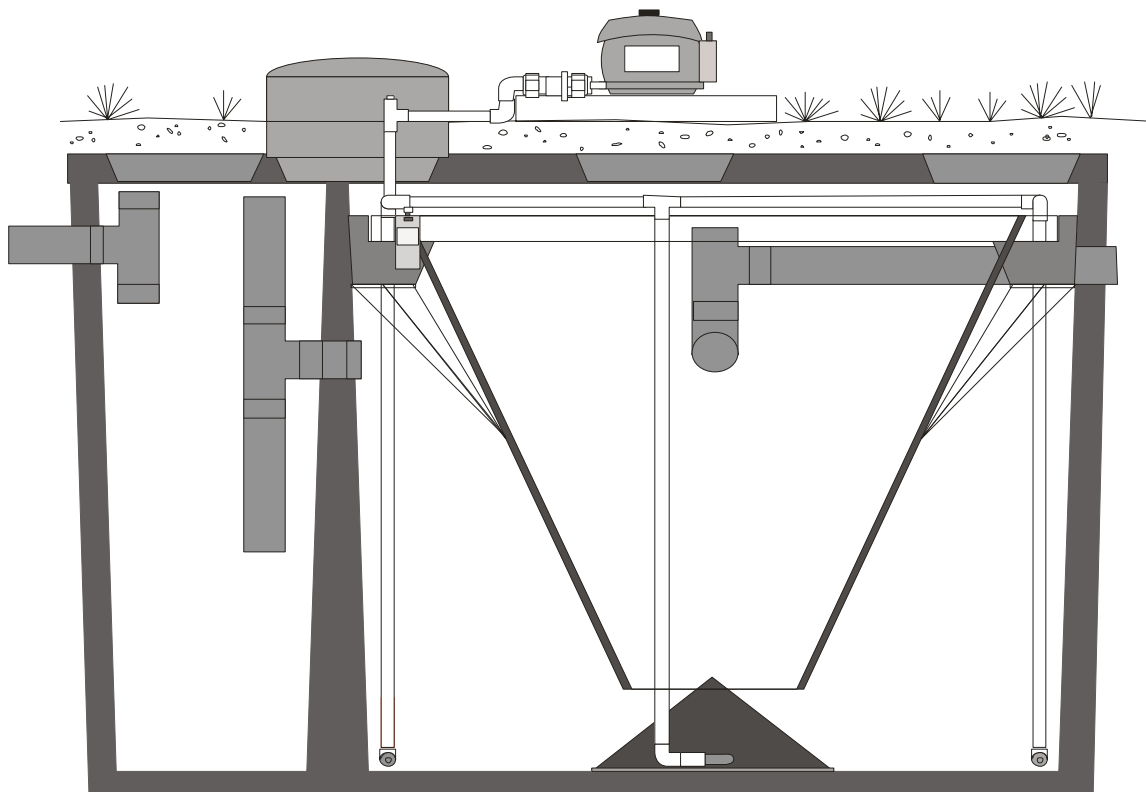

REVISIONS	DESCRIPTION	DATE

CRITICAL DIMENSIONS	
A	69.00"
B	57.00"
C	52.00"
D	3.00"
E	74.50"
F	106.00"
G	65.50"
H	97.00"

TROY AIR BLOWER

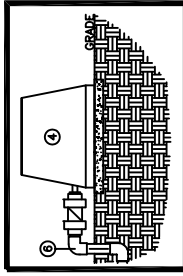

- THE H-SERIES HOOT AEROBIC TREATMENT SYSTEM
- 1) PRETREATMENT TANK- WHERE ANAEROBIC DIGESTION OCCURS AND STORAGE FOR NON-BIODEGRADABLE MATERIALS.
  - 2) AERATION CHAMBER- WHERE AIR IS INTRODUCED INTO SEWAGE FOR DIGESTION.
  - 3) CLARIFIER- A STILL CHAMBER WHERE SOLIDS SETTLE OUT AND THE CLEAR EFFLUENT RISES.
  - 4) TROY AIR LINEAR AIR BLOWERS- LONG LIFE, EFFICIENT LINEAR AIR BLOWERS WHICH COMPRESS AIR UNDER PRESSURE DELIVERS IT TO THE TANK. MUST BE REMOTELY MOUNTED UP TO 50' FROM SYSTEM. MUST MAINTAIN 1/8" SLOPE TOWARDS TANK FOR DRAINAGE.
  - 5) AIR MANIFOLD- DELIVERS THE AIR FROM THE LINE TO THE STONES FOR DIFFUSION INTO THE SEWAGE.
  - 6) AERATION LINE- DELIVERS THE AIR FROM THE PUMP TO THE MANIFOLD. CHECK VALVE INCLUDED.
  - 7) AERATION STONE- AIR IS FINELY DIFFUSED FROM THE STONE INTO THE AERATION CHAMBER.
  - 8) 15" COVERS- PROVIDE ASSEMBLY PORT ACCESS INSIDE OF THE SYSTEM. (NOT REQUIRED FOR REGULAR SERVICE)

**HOOT SYSTEMS, LLC**  
www.hootsystems.com

THIS DRAWING IS THE PROPRIETARY PROPERTY OF HOOT SYSTEMS LLC. REPRODUCTION, DISCLOSURE OR USE OF ANY PART OF THIS DRAWING OR ANY INFORMATION THEREIN IS EXPRESSLY PROHIBITED WITHOUT PRIOR WRITTEN CONSENT OF HOOT SYSTEMS LLC.

**DESCRIPTION:** 500 GPD GRAVITY DISCHARGE SYSTEM  
H-500 A (2- RISER POLYLOK ACCESS)

**PART #**  
H-500A (2R)

**DATE:** 9-7-09  
**DRAWN BY:** AY  
**CHECK BY:** RS  
**SCALE:** N.T.S.

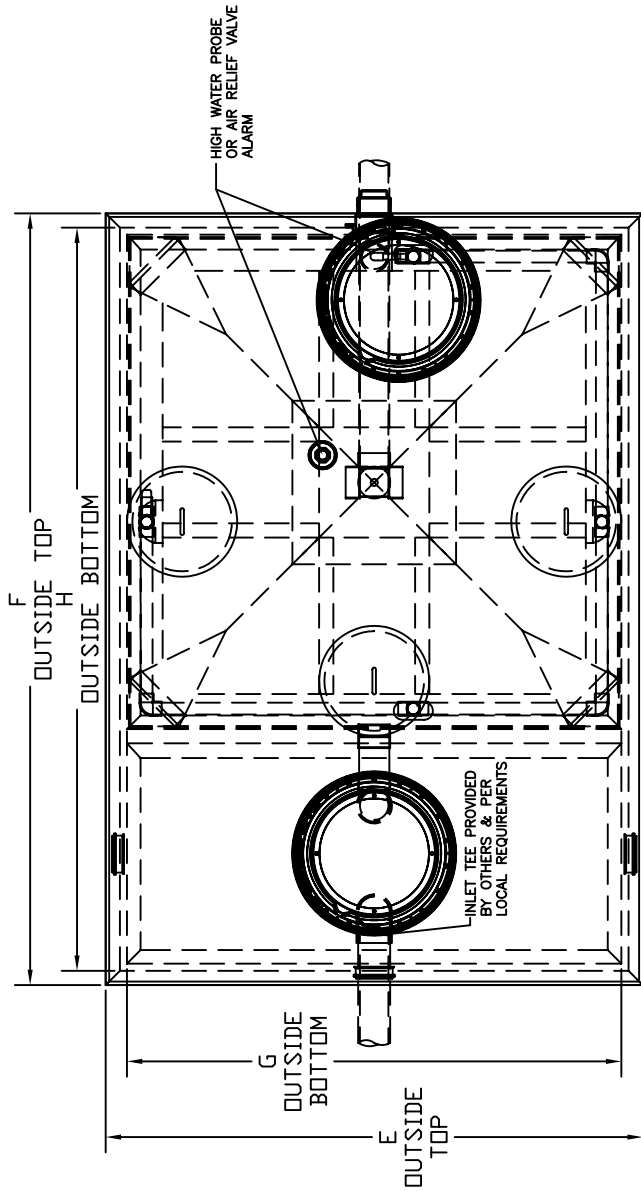

PLAN VIEW

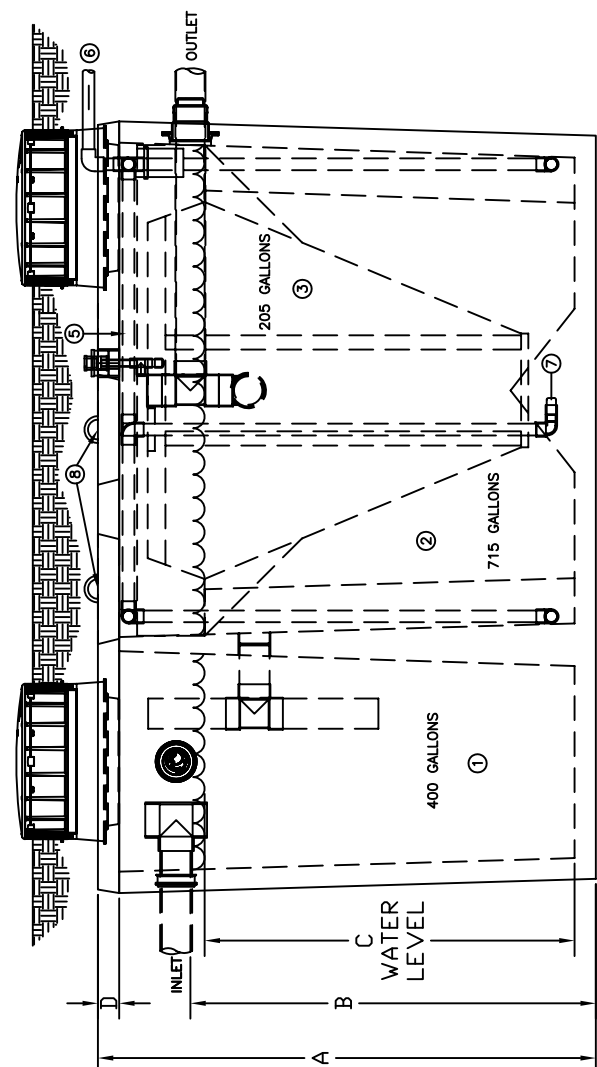

SIDE ELEVATION

REVISIONS	DESCRIPTION	DATE

CRITICAL DIMENSIONS	
A	69.00"
B	57.00"
C	52.00"
D	3.00"
E	74.50"
F	106.00"
G	65.50"
H	97.00"

TROY AIR BLOWER

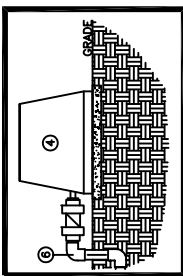

THE H-SERIES HOOT AEROBIC TREATMENT SYSTEM

- 1) PRETREATMENT TANK- WHERE ANAEROBIC DIGESTION OCCURS AND STORAGE FOR NON-BIODEGRADABLE MATERIALS.
- 2) AERATION CHAMBER- WHERE AIR IS INTRODUCED INTO SEWAGE FOR DIGESTION.
- 3) CLARIFIER- A STILL CHAMBER WHERE SOLIDS SETTLE OUT AND THE CLEAR EFFLUENT RISES.
- 4) TROY AIR LINEAR AIR BLOWERS- LONG LIFE, EFFICIENT UNDER PRESSURE, COMPRESSED AIR DELIVERED TO THE TANK. MUST BE REMOTELY MOUNTED UP TO 50' FROM SYSTEM. MUST MAINTAIN 1/8" SLOPE TOWARDS TANK FOR DRAINAGE.
- 5) AIR MANIFOLD- DELIVERS THE AIR FROM THE LINE TO THE STONES FOR DIFFUSION INTO THE SEWAGE.
- 6) AERATION LINE- DELIVERS THE AIR FROM THE PUMP TO THE MANIFOLD. CHECK VALVE INCLUDED.
- 7) AERATION STONE- AIR IS FINELY DIFFUSED FROM THE STONE INTO THE AERATION CHAMBER.
- 8) 15" COVERS- PROVIDE ASSEMBLY PORT ACCESS INSIDE OF THE SYSTEM. (NOT REQUIRED FOR REGULAR SERVICE)



**HOOT SYSTEMS, LLC**  
www.hootsystems.com

THIS DRAWING IS THE PROPRIETARY PROPERTY OF HOOT SYSTEMS LLC. REPRODUCTION, DISCLOSURE OR USE OF ANY PART OF THIS DRAWING OR ANY INFORMATION THEREIN IS EXPRESSLY PROHIBITED WITHOUT PRIOR WRITTEN CONSENT OF HOOT SYSTEMS LLC.

PART #

DESCRIPTION: 600 GPD GRAVITY DISCHARGE SYSTEM  
H-500 A (2- RISER POLYLOK ACCESS)

H-600A (2R)

DATE: 9-7-09  
DRAWN BY: AY  
CHECK BY: RS  
SCALE: N.T.S.

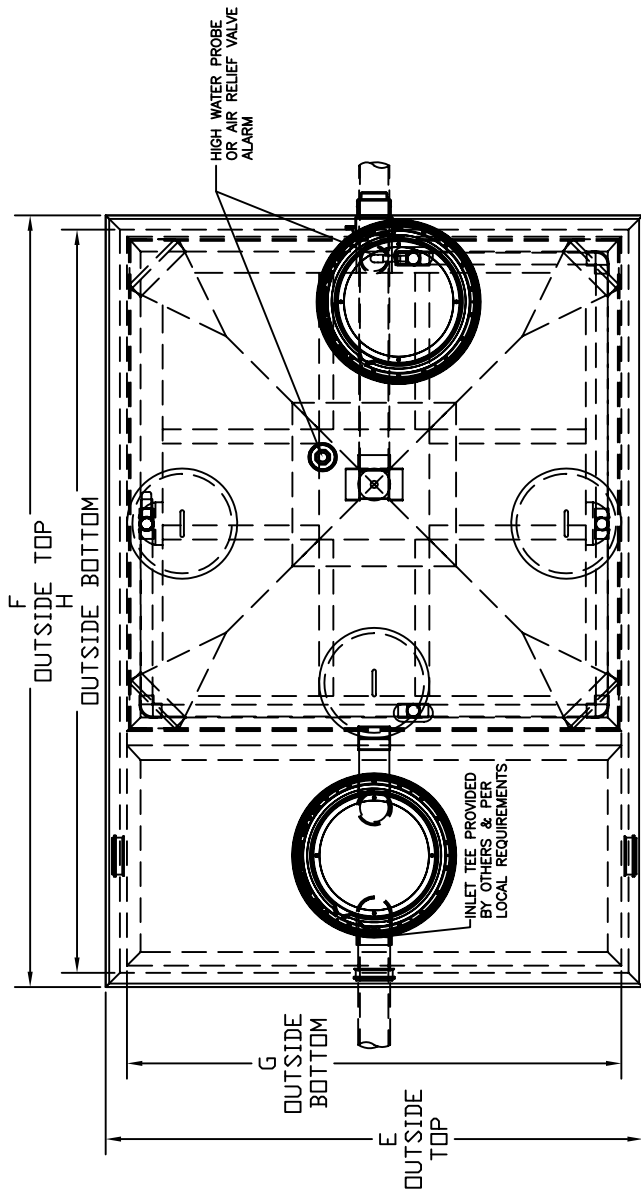

PLAN VIEW

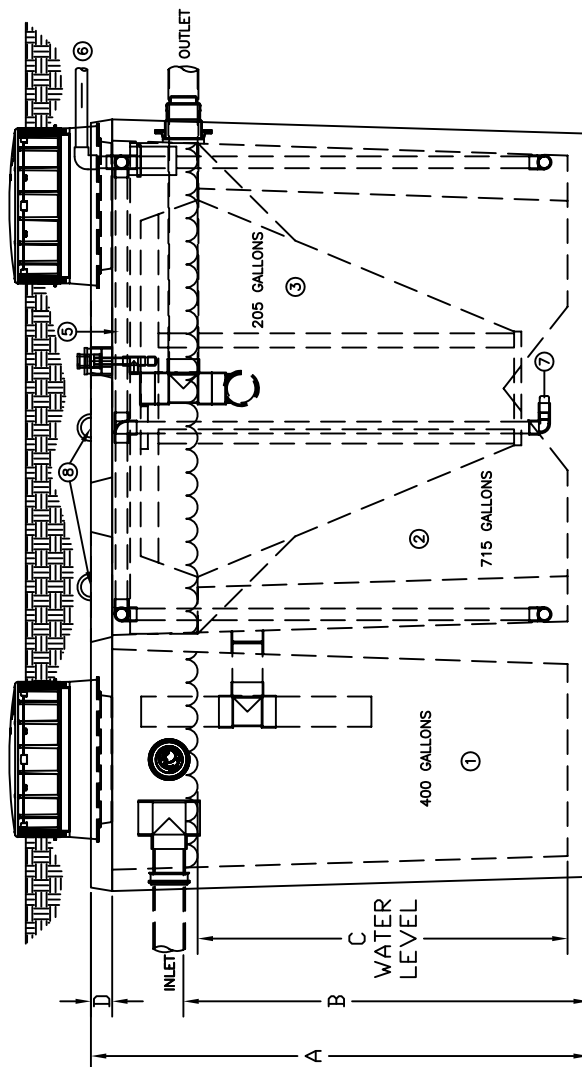

SIDE ELEVATION

REVISIONS	DESCRIPTION	DATE

CRITICAL DIMENSIONS	
A	72.00"
B	62.00"
C	57.00"
D	3.00"
F	83.50"
F	179.00"
G	78.50"
H	174.00"
J	89.50"
K	15.00"
L	25.50"
M	16.50"

TROY AIR BLOWER

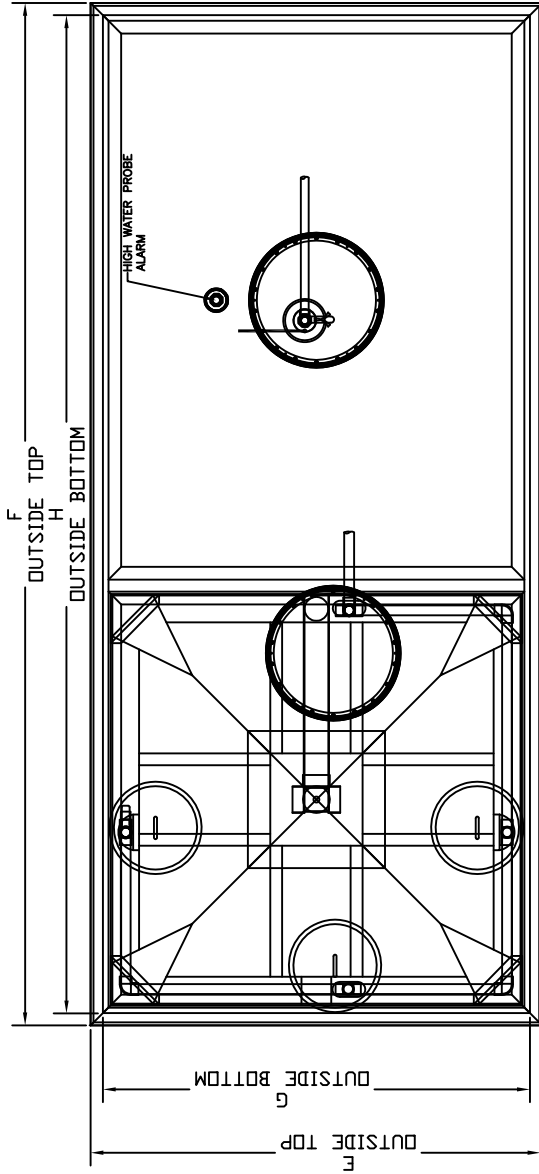
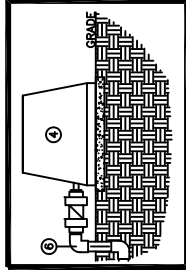

PLAN VIEW

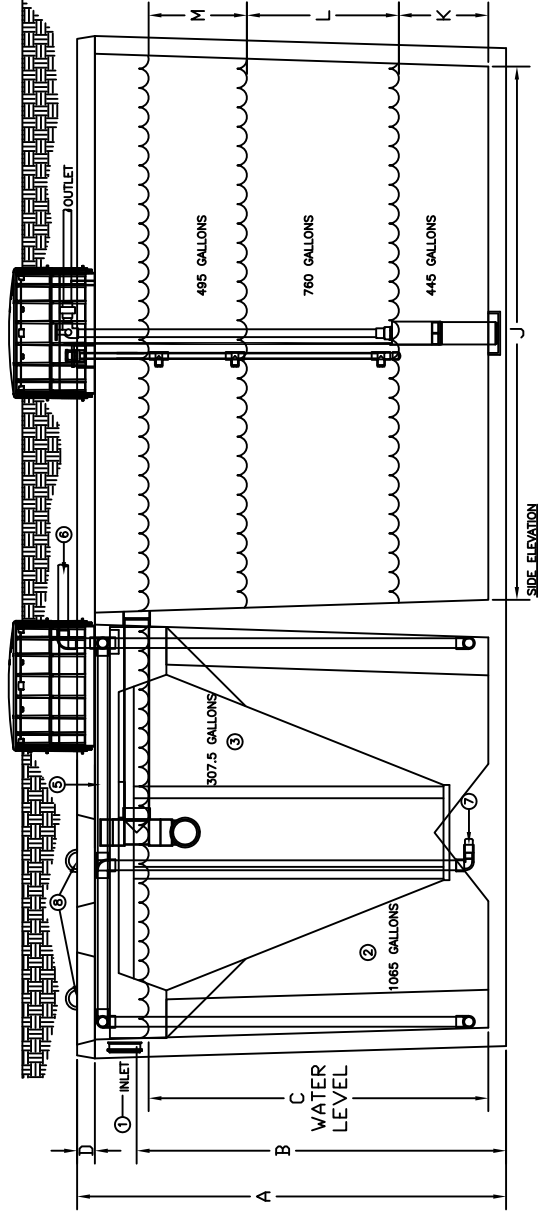

SIDE ELEVATION

THE HOOT AEROBIC TREATMENT SYSTEM

- 1) SEPARATE PRETREATMENT TANK REQUIRED (MIN. 600 GALLONS) WHERE ANAEROBIC DIGESTION OCCURS AND STORAGE FOR NON-Biodegradable MATERIALS.
- 2) AERATION CHAMBER- WHERE AIR IS INTRODUCED INTO SEWAGE FOR DIGESTION.
- 3) CLARIFIER- A STILL CHAMBER WHERE SOLIDS SETTLE OUT AND THE CLEAR EFFLUENT RISES.
- 4) TROY AIR LINEAR AIR BLOWER- LONG LIFE, EFFICIENT LINEAR BLOWER WHICH COMPRESSES ATMOSPHERIC AIR AND UNDER PRESSURE DELIVERS IT TO THE TANK. MAY BE REVERSELY MOUNTED UP TO 50' FROM SYSTEM. MUST MAINTAIN 1/8" SLOPE TOWARDS TANK FOR DRAINAGE TO TANK.
- 5) AIR MANIFOLD- DELIVERS THE AIR FROM THE LINE TO THE STONES FOR DIFFUSION INTO THE SEWAGE.
- 6) AERATION LINE- DELIVERS THE AIR FROM THE PUMP TO THE MANIFOLD. CHECK VALVE INCLUDED.
- 7) AERATION STONE- AIR IS FINELY DIFFUSED FROM THE STONE INTO THE AERATION CHAMBER.
- 8) 15" COVERS- PROVIDE ACCESS TO EACH COMPONENT OF THE SYSTEM FOR SERVICE AND REPAIR. MUST BE BROUGHT TO GRADE AS REQUIRED PER LOCAL CODE.



**HOOT SYSTEMS, LLC**

www.hootsystems.com

THIS DRAWING IS THE PROPRIETARY PROPERTY OF HOOT SYSTEMS LLC. REPRODUCTION, DISCLOSURE OR USE OF ANY PART OF THIS DRAWING OR ANY INFORMATION THEREIN IS EXPRESSLY PROHIBITED WITHOUT PRIOR WRITTEN CONSENT OF HOOT SYSTEMS LLC.

PART #

DESCRIPTION: 750 GPD SYSTEM w/ 1750 PUMP TANK  
H-750 AN 2 RISER (AER. & P. TANK)

DATE: 9-07-09

DRAWN BY: AY

CHECK BY: RS

SCALE: N.T.S.

H-750-AN

REVISIONS	DESCRIPTION	DATE

CRITICAL DIMENSIONS	
A	78.00"
B	69.25"
C	65.00"
D	3.00"
F	89.00"
F	89.00"
G	80.00"
H	80.00"

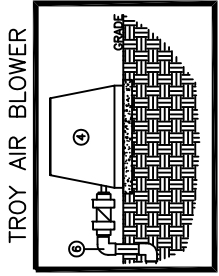

TROY AIR BLOWER

**THE HOOT AEROBIC TREATMENT SYSTEM**

- 1) SEPARATE PRETREATMENT TANK REQUIRED (MIN. 800 GALLONS) - WHERE ANAEROBIC DIGESTION OCCURS AND STORAGE FOR NON-BIODEGRADABLE MATERIALS.
- 2) AERATION CHAMBER- WHERE AIR IS INTRODUCED INTO SEWAGE FOR DIGESTION.
- 3) CLARIFIER- A STILL CHAMBER WHERE SOLIDS SETTLE OUT AND THE CLEAR EFFLUENT RISES.
- 4) TROY AIR BLOWER- LONG LIFE, EFFICIENT UNIT WHICH COMPRESSES AIR AND DELIVERS IT TO THE TANK UNDER PRESSURE. DELIVERS IT TO THE TANK MANIFOLD REMOTELY MOUNTED UP TO 50' FROM SYSTEM. MUST MAINTAIN 1/8" SLOPE TOWARDS TANK FOR DRAINAGE TO TANK.
- 5) AIR MANIFOLD- DELIVERS THE AIR FROM THE LINE TO THE STONES FOR DIFFUSION INTO THE SEWAGE.
- 6) AERATION LINE- DELIVERS THE AIR FROM THE PUMP TO THE MANIFOLD. CHECK VALVE INCLUDED.
- 7) AERATION STONE- AIR IS FINELY DIFFUSED FROM THE STONE INTO THE AERATION CHAMBER.
- 8) 15" COVERS- PROVIDE ACCESS TO EACH COMPONENT OF THE SYSTEM FOR SERVICE. ARE BROUGHT TO GRADE IE. REQUIRED PER LOCAL CODE.



**HOOT SYSTEMS, LLC**  
www.hootsystems.com

THIS DRAWING IS THE PROPRIETARY PROPERTY OF HOOT SYSTEMS LLC. REPRODUCTION, DISCLOSURE OR USE OF ANY PART OF THIS DRAWING OR ANY INFORMATION THEREIN IS EXPRESSLY PROHIBITED WITHOUT PRIOR WRITTEN CONSENT OF HOOT SYSTEMS LLC.

DESCRIPTION: 1000 GPD GRAVITY DISCHARGE SYSTEM  
H-1000-A w/ POLYLOK ACCESS

PART #  
H-1000-A

DATE: 9-7-09  
DRAWN BY: AY  
CHECK BY: RS  
SCALE: N.T.S.

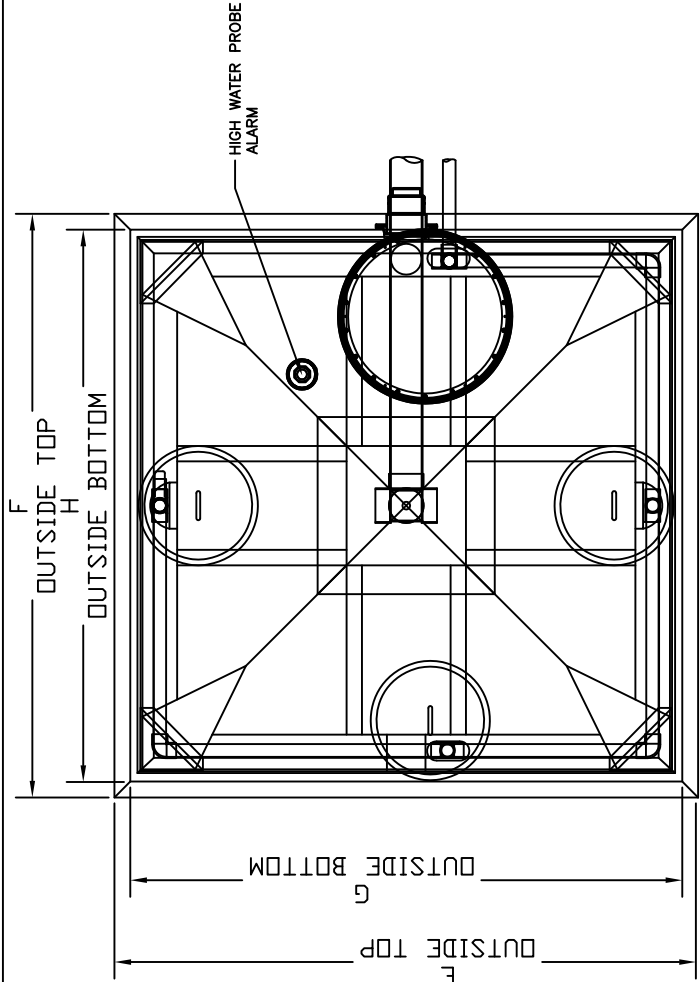

PLAN VIEW

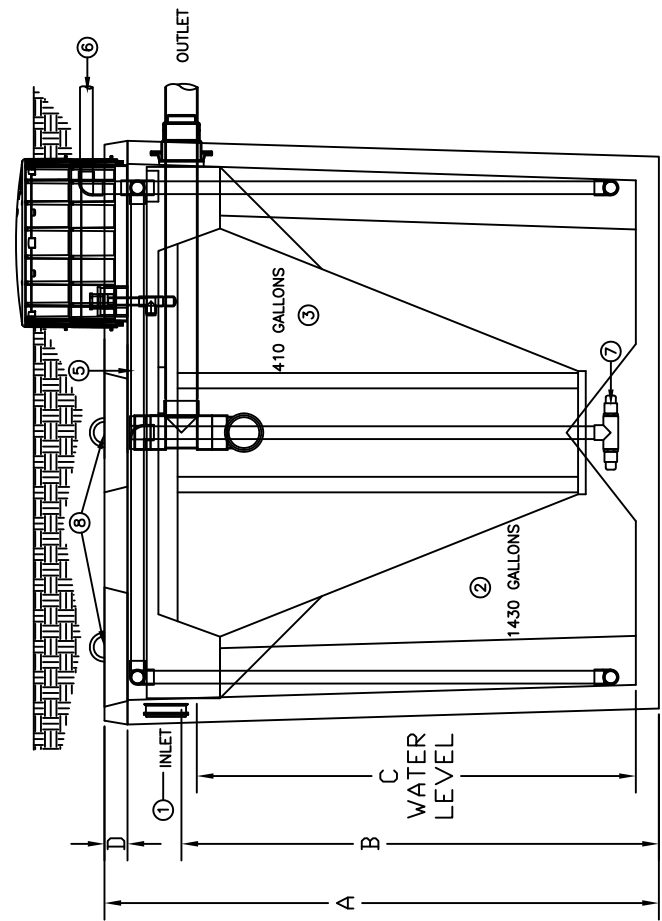

SIDE ELEVATION



REVISIONS	DESCRIPTION	DATE

CRITICAL DIMENSIONS	
A	76.00"
B	69.25"
C	65.00"
D	3.00"
E	89.00"
F	157.00"
G	80.00"
H	148.00"
J	89.50"
K	15.00"
L	32.00"
M	14.00"

TROY AIR BLOWER

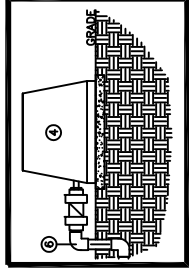

PLAN VIEW

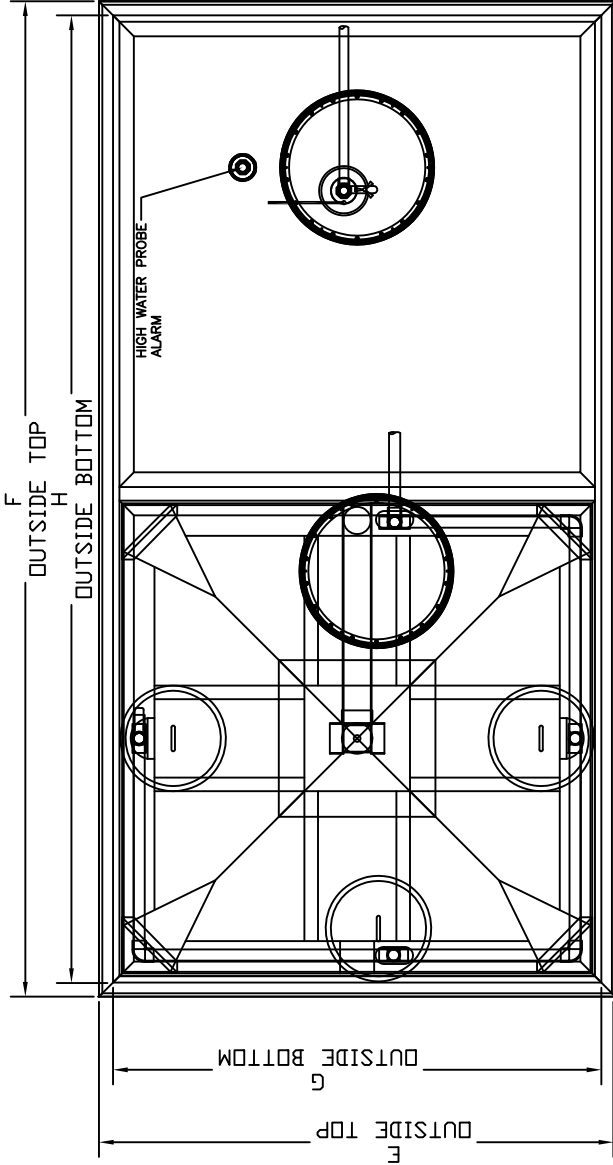

SIDE ELEVATION

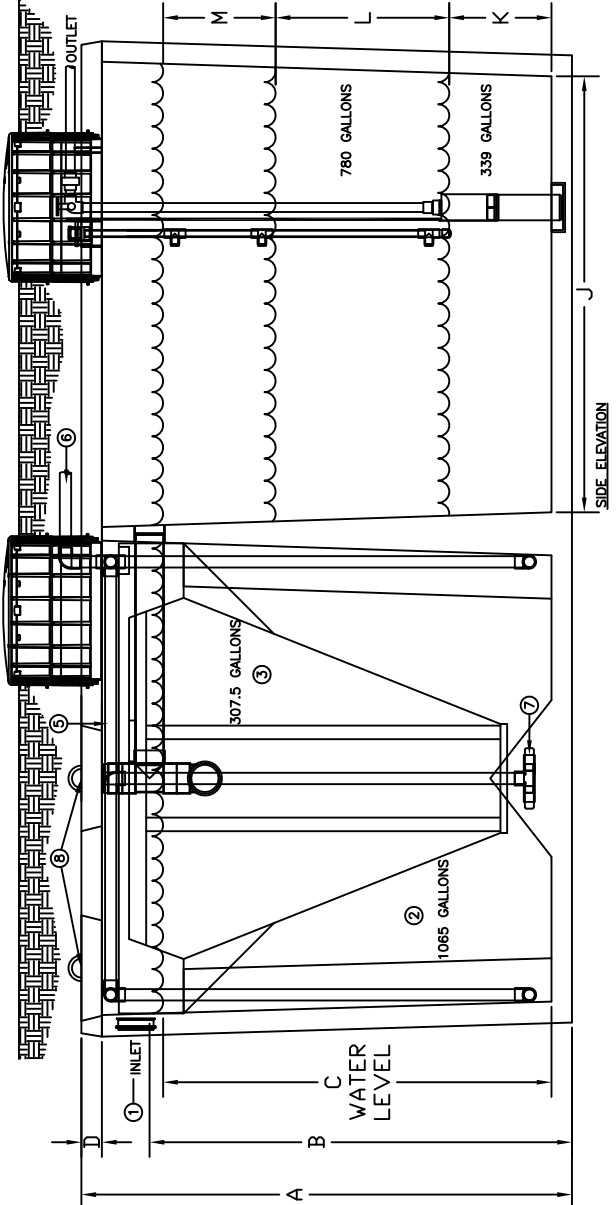

THE HOOT AEROBIC TREATMENT SYSTEM

- 1) SEPARATE PRETREATMENT TANK REQUIRED (MIN. 800 GALLONS) - WHERE ANAEROBIC DIGESTION OCCURS AND STORAGE FOR NON-BIOGRADEABLE MATERIALS.
- 2) AERATION CHAMBER- WHERE AIR IS INTRODUCED INTO SEWAGE FOR DIGESTION.
- 3) CLARIFIER- A STILL CHAMBER WHERE SOLIDS SETTLE OUT AND THE CLEAR EFFLUENT RISES.
- 4) TROY AIR LINEAR AIR BLOWER- LONG LIFE, EFFICIENT AND QUIET. COMPRESSOR AND MOTOR ARE REMOTELY MOUNTED UP TO 50' FROM SYSTEM. MUST MAINTAIN 1/8" SLOPE TOWARDS TANK FOR DRAINAGE TO TANK.
- 5) AIR MANIFOLD- DELIVERS THE AIR FROM THE LINE TO THE STONES FOR DIFFUSION INTO THE SEWAGE.
- 6) AERATION LINE- DELIVERS THE AIR FROM THE PUMP TO THE MANIFOLD. CHECK VALVE INCLUDED.
- 7) AERATION STONE- AIR IS FINELY DIFFUSED FROM THE STONE INTO THE AERATION CHAMBER.
- 8) 15" COVERS- PROVIDE ACCESS TO EACH COMPONENT OF THE SYSTEM FOR SERVICE. ARE BROUGHT TO GRADE IE. REQUIRED PER LOCAL CODE.



**HOOT SYSTEMS, LLC**  
www.hootsystems.com

THIS DRAWING IS THE PROPRIETARY PROPERTY OF HOOT SYSTEMS LLC. REPRODUCTION, DISCLOSURE OR USE OF ANY PART OF THIS DRAWING OR ANY INFORMATION THEREIN IS EXPRESSLY PROHIBITED WITHOUT PRIOR WRITTEN CONSENT OF HOOT SYSTEMS LLC.

DESCRIPTION: 1,000 GPD NIGHT PUMPING SYSTEM

H-1000 AN - 2 RISER (AER. & P. TANK)

DRAWN BY: AY CHECK BY: RS

SCALE: N.T.S.

DATE: 9-07-09

PART #

H-1000-AN



## Hoot H-Series Service and Inspection Form

This testing and reporting shall be completed, signed and dated after each inspection. One copy shall be retained by the maintenance company. The second copy is sent to the local permitting authority and the third copy is sent to the system owner along with an invoice for services by the maintenance company.

1. Actual Date of Visit: \_\_\_\_\_
2. System Inspection of \_\_\_\_\_
- Owner: \_\_\_\_\_
- Address: \_\_\_\_\_
- City, St., Zip: \_\_\_\_\_

Inspected Items:	Operational	Inoperative	Not Applicable
Aerator.....	<input type="checkbox"/>	<input type="checkbox"/>	
Aeration Plumbing.....	<input type="checkbox"/>	<input type="checkbox"/>	
Air Filter.....	<input type="checkbox"/>	<input type="checkbox"/>	
Effluent Pump (if applicable).....	<input type="checkbox"/>	<input type="checkbox"/>	<input type="checkbox"/>
OK System Light.....	<input type="checkbox"/>	<input type="checkbox"/>	<input type="checkbox"/>
Alarm Operation.....	<input type="checkbox"/>	<input type="checkbox"/>	<input type="checkbox"/>
D-Box .....	<input type="checkbox"/>	<input type="checkbox"/>	<input type="checkbox"/>

Air Filter must be cleaned each service visit. Operation of effluent disposal system must be made each visit (if pumped effluent system). A system with greater than 70% Settleable Solids in the aeration chamber must be pumped to avoid solids leaving the tank for the drainfield.

3. Repairs to system (list all components replaced): \_\_\_\_\_

4. Tests Required and Results:

Test	Required	Results	Test Method
BOD (Grab)	<input type="checkbox"/>	_____	_____
TSS (Grab)	<input type="checkbox"/>	_____	_____
pH (Grab)	<input type="checkbox"/>	_____	_____

5. Comments: \_\_\_\_\_

Signature of Inspector: \_\_\_\_\_ Operator License # \_\_\_\_\_

For Additional Information, Please Contact:



**HOOT Aerobic Systems, Inc.**

2885 Highway 14 East Lake Charles, LA 70607  
(337) 474-2804 phone (337) 477-7904 fax

[www.hootsystems.com](http://www.hootsystems.com)