

WEINMAN®

INSTALLATION and OPERATION MANUAL Submersible Sewage Ejector

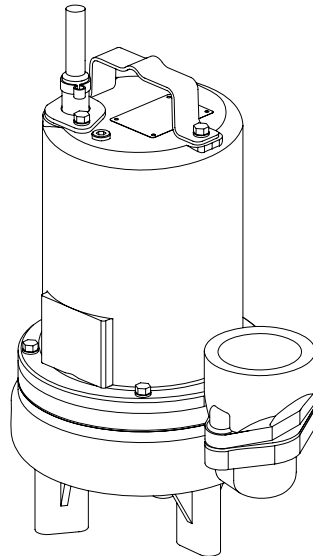
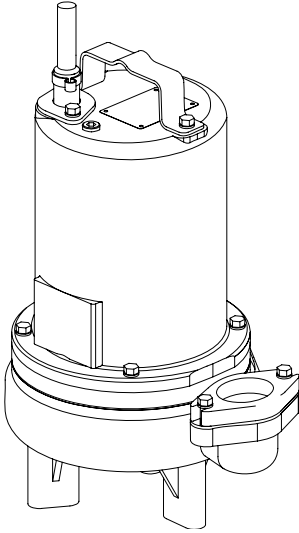

Series: WE & 3WE
.5, .75 & 1 HP, 1750RPM, 60 Hz.

IMPORTANT!

Read all instructions in this manual before operating pump.

As a result of Crane Pumps & Systems, Inc., constant product improvement program, product changes may occur. As such Crane Pumps & Systems reserves the right to change product without prior written notification.

CRANE[®]

A Crane Co. Company

PUMPS & SYSTEMS

420 Third Street
Piqua, Ohio 45356
Phone: (937) 778-8947
Fax: (937) 773-7157
www.cranepumps.com

83 West Drive, Bramton
Ontario, Canada L6T 2J6
Phone: (905) 457-6223
Fax: (905) 457-2650

Form No. 108038-Rev. N

TABLE OF CONTENTS

SAFETY FIRST	3
A. PUMP SPECIFICATIONS	4 - 5
B. GENERAL INFORMATION	6
C. INSTALLATION	6 - 7
ELECTRICAL DATA	8
D. START-UP OPERATION	8
E. PREVENTATIVE MAINTENANCE	8
F. SERVICE and REPAIR	9 - 13
G. REPLACEMENT PARTS.....	12
TRUBLE SHOOTING	14
CROSS-SECTION (Fig. 15).....	15
EXPLODED VIEW (Fig. 16).....	16
PARTS LIST	17 - 18
RETURNED GOODS POLICY.....	19
WARRANTY	20
START-UP REPORT	21 - 22
WARRANTY REGISTRATION	
SPECIAL TOOLS AND EQUIPMENT	
INSULATION TESTER (MEGGER)	
DIELECTRIC TESTER	
SEAL TOOL KIT (see parts list)	
PRESSURE GAUGE KIT (see parts list)	

SAFETY FIRST!

Please Read This Before Installing Or Operating Pump.
This information is provided for **SAFETY and to PREVENT EQUIPMENT PROBLEMS**. To help recognize this information, observe the following symbols:



IMPORTANT! Warns about hazards that can result in personal injury or Indicates factors concerned with assembly, installation, operation, or maintenance which could result in damage to the machine or equipment if ignored.

CAUTION ! Warns about hazards that can or will cause minor personal injury or property damage if ignored. Used with symbols below.

WARNING ! Warns about hazards that can or will cause serious personal injury, death, or major property damage if ignored. Used with symbols below.



Hazardous fluids can cause fire or explosions, burnes or death could result.



Extremely hot - Severe burnes can occur on contact.



Biohazard can cause serious personal injury.



Hazardous fluids can Hazardous pressure, eruptions or explosions could cause personal injury or property damage.



Rotating machinery Amputation or severe laceration can result.



Hazardous voltage can shock, burn or cause death.

Only qualified personnel should install, operate and repair pump. Any wiring of pumps should be performed by a qualified electrician.



WARNING ! - To reduce risk of electrical shock, pumps and control panels must be properly grounded in accordance with the National Electric Code (NEC) or the Canadian Electrical Code (CEC) and all applicable state, province, local codes and ordinances.



WARNING! - To reduce risk of electrical shock, always disconnect the pump from the power source before handling or servicing. Lock out power and tag.



WARNING! Operation against a closed discharge valve will cause premature bearing and seal failure on any pump, and on end suction and self priming pump the heat build may cause the generation of steam with resulting dangerous pressures. It is recommended that a high case temperature switch or pressure relief valve be installed on the pump body.



CAUTION ! Never operate a pump with a plug-in type power cord without a ground fault circuit interrupter.



CAUTION! Pumps build up heat and pressure during operation-allow time for pumps to cool before handling or servicing.



WARNING! - DO NOT pump hazardous materials (flammable, caustic, etc.) unless the pump is specifically designed and designated to handle them.



Do not block or restrict discharge hose, as discharge hose may whip under pressure.



WARNING! - DO NOT wear loose clothing that may become entangled in the impeller or other moving parts.



WARNING! - Keep clear of suction and discharge openings. **DO NOT** insert fingers in pump with power connected.



Always wear eye protection when working on pumps.



Make sure lifting handles are securely fastened each time before lifting. **DO NOT** operate pump without safety devices in place. Always replace safety devices that have been removed during service or repair. Secure the pump in its operating position so it can not tip over, fall or slide.



DO NOT exceed manufacturers recommendation for maximum performance, as this could cause the motor to overheat.



DO NOT remove cord and strain relief. Do not connect conduit to pump.



WARNING! Cable should be protected at all times to avoid punctures, cut, bruises and abrasions - inspect frequently. Never handle connected power cords with wet hands.



WARNING! To reduce risk of electrical shock, all wiring and junction connections should be made per the NEC or CEC and applicable state or province and local codes. Requirements may vary depending on usage and location.



WARNING! Submersible Pumps are not approved for use in swimming pools, recreational water installations, decorative fountains or any installation where human contact with the pumped fluid is common.



WARNING! Products Returned Must Be Cleaned, Sanitized, Or Decontaminated As Necessary Prior To Shipment, To Insure That Employees Will Not Be Exposed To Health Hazards In Handling Said Material. All Applicable Laws And Regulations Shall Apply.



Bronze/brass and bronze/brass fitted pumps may contain lead levels higher than considered safe for potable water systems. Lead is known to cause cancer and birth defects or other reproductive harm. Various government agencies have determined that leaded copper alloys should not be used in potable water applications. For non-leaded copper alloy materials of construction, please contact factory.



IMPORTANT! - Crane Pumps & Systems, Inc. is not responsible for losses, injury, or death resulting from a failure to observe these safety precautions, misuse or abuse of pumps or equipment.

SECTION: A - PUMP SPECIFICATIONS: 2" Pumps

DISCHARGE2" NPT, Female, Vertical, Bolt-on Flange
LIQUID TEMP104°F (40°C) Continuous
VOLUTECast Iron ASTM A-48, Class 30
MOTOR HOUSING ...Cast Iron ASTM A-48, Class 30
SEAL PLATECast Iron ASTM A-48, Class 30
IMPELLER:
Design2 Vane, open, with pump out vanes on back side. Dynamically balanced, ISO G6.3
MaterialCast Iron ASTM A-48, Class 30
SHAFT.....416 Stainless Steel
SQUARE RINGS.....Buna-N
HARDWARE300 Series Stainless Steel
PAINTAir Dry Enamel
SEAL:
DesignSingle Mechanical
Material.....Carbon/Ceramic/Buna-N
 Hardware -300 Series Stainless
CORD ENTRY20 ft. (6.1m) Cord with plug on 120 volt Quick connect custom molded for sealing and strain relief
SPEED1750 RPM (Nominal)

UPPER BEARING.....Single Row, Ball, Oil lubricated
Load.....Radial
LOWER BEARING.....Single Row, Ball, Oil lubricated
Load.....Radial & Thrust
MOTOR:
DesignNEMA L -Single Phase, NEMA B -Three phase Torque Curve, Oil Filled, Squirrel Cage Induction
Insulation.....Class B
SINGLE PHASE.....Permanent Split Capacitor (PSC) Includes Overload Protection in Motor
THREE PHASE.....200-240/480 is Tri-Voltage motor 600V. Requires overload Protection to be included in control panel
LEVEL CONTROL "A" - Wide Angle, PVC, Mechanical, 15 ft (5m) cord with Piggy-Back Plug, N/O
OPTIONAL EQUIPMENT Seal Material, Impeller Trims, Additional cord

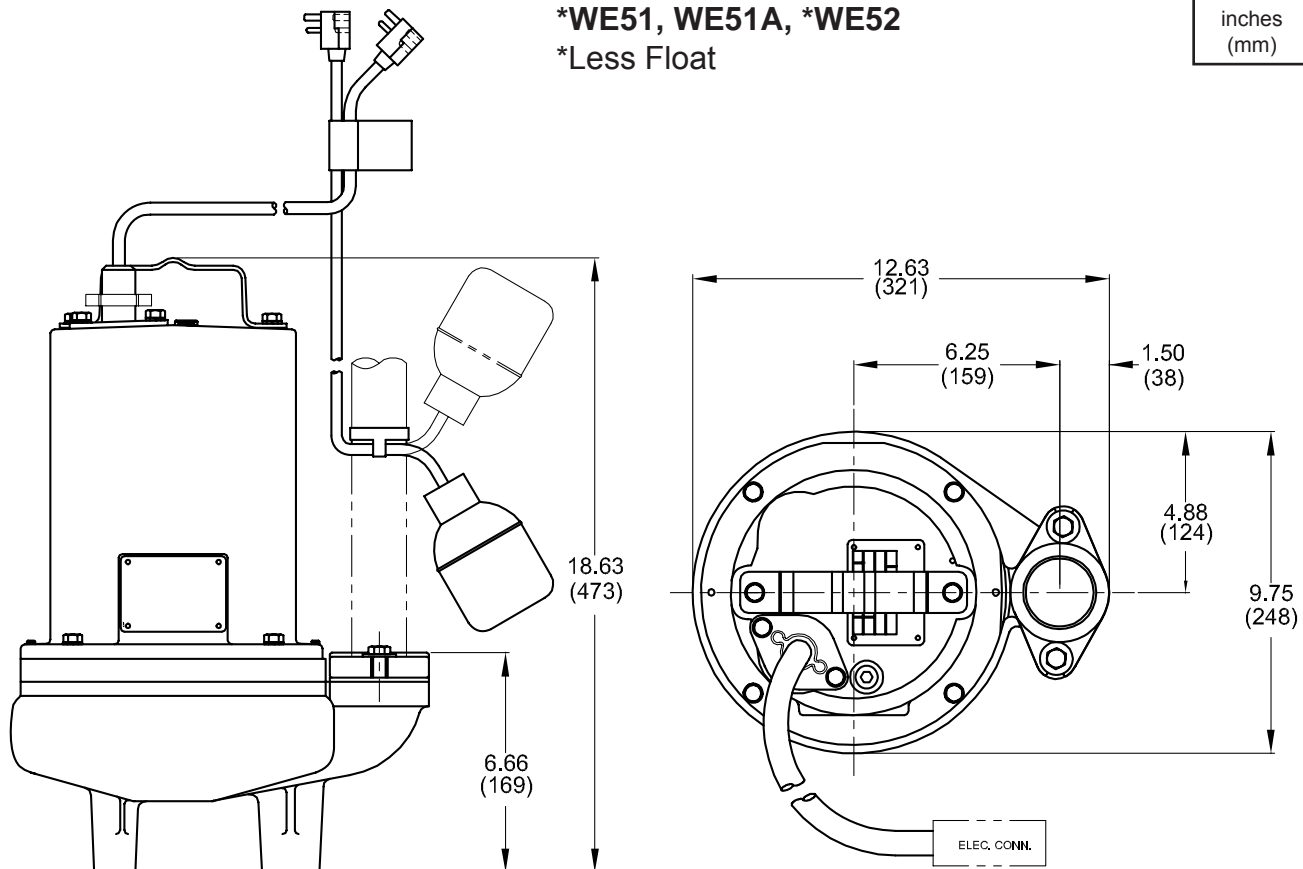

IMPORTANT !

- 1.) PUMP MAY BE OPERATED "DRY" FOR EXTENDED PERIODS WITHOUT DAMAGE TO MOTOR AND/OR SEALS.
- 2.) THIS PUMP IS APPROPRIATE FOR THOSE APPLICATIONS SPECIFIED AS CLASS I DIVISION II HAZARDOUS LOCATIONS.
- 3.) THIS PUMP IS NOT APPROPRIATE FOR THOSE APPLICATIONS SPECIFIED AS CLASS I DIVISION I HAZARDOUS LOCATIONS.
- 4.) INSTALLATIONS SUCH AS DECORATIVE FOUNTAINS OR WATER FEATURES PROVIDED FOR VISUAL ENJOYMENT MUST BE INSTALLED IN ACCORDANCE WITH THE NATIONAL ELECTRIC CODE ANSI/NFPA 70 AND/OR THE AUTHORITY HAVING JURISDICTION. THIS PUMP IS NOT INTENDED FOR USE IN SWIMMING POOLS, RECREATIONAL WATER PARKS, OR INSTALLATIONS IN WHICH HUMAN CONTACT WITH PUMPED MEDIA IS A COMMON OCCURRENCE.

SECTION: A - PUMP SPECIFICATIONS: 3" Pumps

DISCHARGE3" NPT, Female, Vertical, Bolt-on Flange
LIQUID TEMP 104°F (40°C) Continuous
VOLUTECast Iron ASTM A-48, Class 30
MOTOR HOUSING ...Cast Iron ASTM A-48, Class 30
SEAL PLATECast Iron ASTM A-48, Class 30
IMPELLER:
Design2 Vane, open, with pump out vanes on back side. Dynamically balanced, ISO G6.3
MaterialCast Iron ASTM A-48, Class 30
SHAFT416 Stainless Steel
SQUARE RINGS.....Buna-N
HARDWARE300 Series Stainless Steel
PAINTAir Dry Enamel
SEAL:
DesignSingle Mechanical or Tandem Mechanical with Oil Filled Reservoir
Material.....Carbon/Ceramic/Buna-N
 Hardware -300 Series Stainless
CORD ENTRY..... 30 ft. (9.1m) Cord. Plug on 120 Volt Quick connect custom molded for sealing and strain relief

SPEED1750 RPM (Nominal)
UPPER BEARING.....Single Row, Ball, Oil lubricated
Load.....Radial
LOWER BEARING....Single Row, Ball, Oil lubricated
Load.....Radial & Thrust
MOTOR:
DesignNEMA L -Single Phase, NEMA B -Three phase Torque Curve, Oil Filled, Squirrel Cage Induction
InsulationClass B
SINGLE PHASE.....Permanent Split Capacitor (PSC) Includes Overload Protection in Motor
THREE PHASE200-240/480 is Tri-Voltage. 600V. Requires Overload Protection to be included in control panel
OPTIONAL EQUIPMENT..... Seal Material, Impeller Trims, Additional cord

3WE Pumps

inches
(mm)

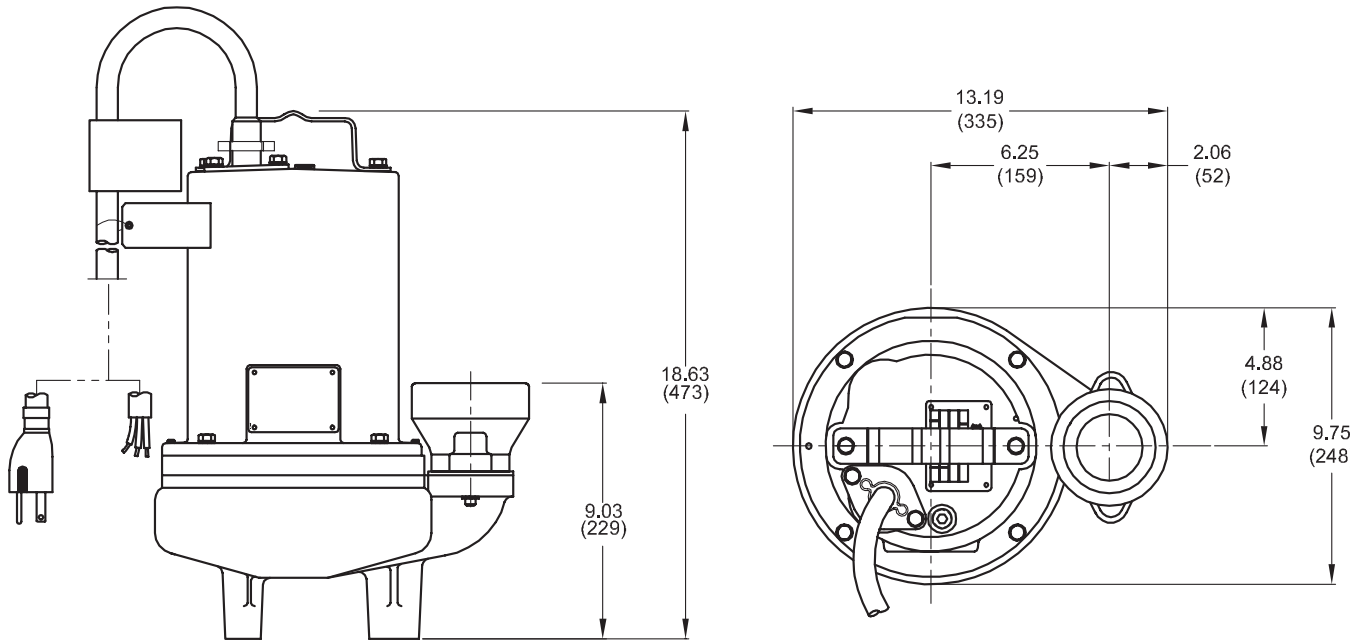

IMPORTANT !

- 1.) PUMP MAY BE OPERATED "DRY" FOR EXTENDED PERIODS WITHOUT DAMAGE TO MOTOR AND/OR SEALS.
- 2.) THIS PUMP IS APPROPRIATE FOR THOSE APPLICATIONS SPECIFIED AS CLASS I DIVISION II HAZARDOUS LOCATIONS.
- 3.) THIS PUMP IS NOT APPROPRIATE FOR THOSE APPLICATIONS SPECIFIED AS CLASS I DIVISION I HAZARDOUS LOCATIONS.
- 4.) INSTALLATIONS SUCH AS DECORATIVE FOUNTAINS OR WATER FEATURES PROVIDED FOR VISUAL ENJOYMENT MUST BE INSTALLED IN ACCORDANCE WITH THE NATIONAL ELECTRIC CODE ANSI/NFPA 70 AND/OR THE AUTHORITY HAVING JURISDICTION. THIS PUMP IS NOT INTENDED FOR USE IN SWIMMING POOLS, RECREATIONAL WATER PARKS, OR INSTALLATIONS IN WHICH HUMAN CONTACT WITH PUMPED MEDIA IS A COMMON OCCURRENCE.

SECTION B: GENERAL INFORMATION

B-1) To the Purchaser:

Congratulations! You are the owner of one of the finest pumps on the market today. CP&S pumps are products engineered and manufactured of high quality components. Over one hundred years of pump building experience along with a continuing quality assurance program combine to produce a pump which will stand up to the toughest applications. This manual will provide helpful information concerning installation, maintenance, and proper service guidelines.

B-2) Receiving:

Upon receiving the pump, it should be inspected for damage or shortages. If damage has occurred, file a claim immediately with the company that delivered the pump. If the manual is removed from the packaging, do not lose or misplace.

B-3) Storage:

Short Term- CP&S Pumps are manufactured for efficient performance following short inoperative periods in storage. For best results, pumps can be retained in storage, as factory assembled, in a dry atmosphere with constant temperatures for up to six (6) months.

Long Term- Any length of time exceeding six (6) months, but not more than twenty-four (24) months. The unit should be stored in a temperature controlled area, a roofed over walled enclosure that provides protection from the elements (rain, snow, wind-blown dust, etc.), and whose temperature can be maintained between +40 deg. F and +120 deg. F. (4.4 - 49°C). Pump should be stored in its original shipping container. On initial start up, rotate impeller by hand to assure seal and impeller rotate freely. If it is required that the pump be installed and tested before the long term storage begins, such installation will be allowed provided:

- 1.) The pump is not installed under water for more than one (1) month.
- 2.) Immediately upon satisfactory completion of the test, the pump is removed, thoroughly dried, repacked in the original shipping container, and placed in a temperature controlled storage area.

B-4) Service Centers:

For the location of the nearest Weinman Service Center, check your Weinman representative or Crane Pumps & Systems, Inc., Service Department in Piqua, Ohio, telephone (937) 778-8947 or Crane Pumps & Systems Canada, in Brampton, Ontario, (905) 457-6223.

SECTION C: INSTALLATION

C-1) Location:

These pumping units are self-contained and are recommended for use in a sump, lift station or basin. The sump, lift station or basin shall be vented in accordance with local plumbing codes. This pump is designed to pump sewage, effluent, or other nonexplosive or noncorrosive wastewater. and shall **NOT** be installed in locations classified as hazardous in accordance with the National Electrical Code (NEC), ANSI/NFPA 70 or the Canadian Electrical Code (CEC). Never install the pump in a trench, ditch or hole with a dirt bottom; the legs will sink into the dirt and the suction will become plugged.

C-1.1) Submergence:

It is recommended that the pump be operated in the submerged condition and the sump liquid level should never be less than 10 inches above the pump bottom (see Fig. 1).

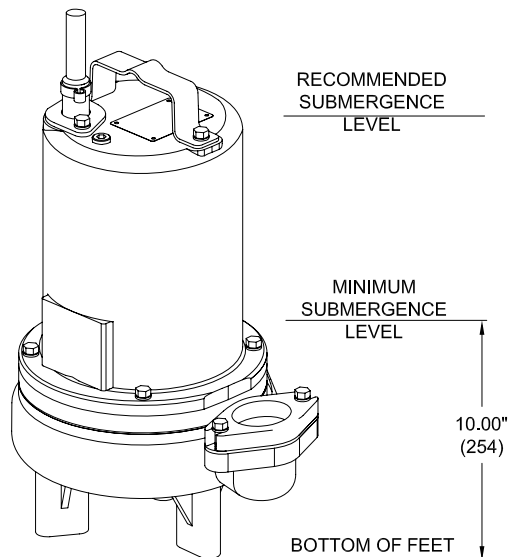

FIGURE 1

C-2) Discharge:

Discharge piping should be as short as possible. Both a check valve and a shut-off valve are recommended for each pump being used. The check valve is used to prevent backflow into the sump. Excessive backflow can cause flooding and/or damage to the pump. The shut-off valve is used to stop system flow during pump or check valve servicing.

Weinman supplies a variety of break-away fitting discharge systems designed to allow the submersible wastewater pump to be installed or removed without requiring personnel to enter the wet well. Contact your local Weinman distributor for complete details.

C-3) Liquid Level Controls:

The level controls are to be supported by a mounting bracket that is attached to the sump wall, cover or junction box. Cord grips are used to hold the cords in place on the mounting bracket. The control level can be changed by loosening the grip and adjusting the cord length as per the plans and specifications. Be certain that the level controls cannot hang up or foul in it's swing and that the pump is completely submerged when the level control is in the "Off" mode.

Figure 2 shows a typical installation of an "A" version float, (an "AU" version will attach to the pump), using a piggy-back plug.

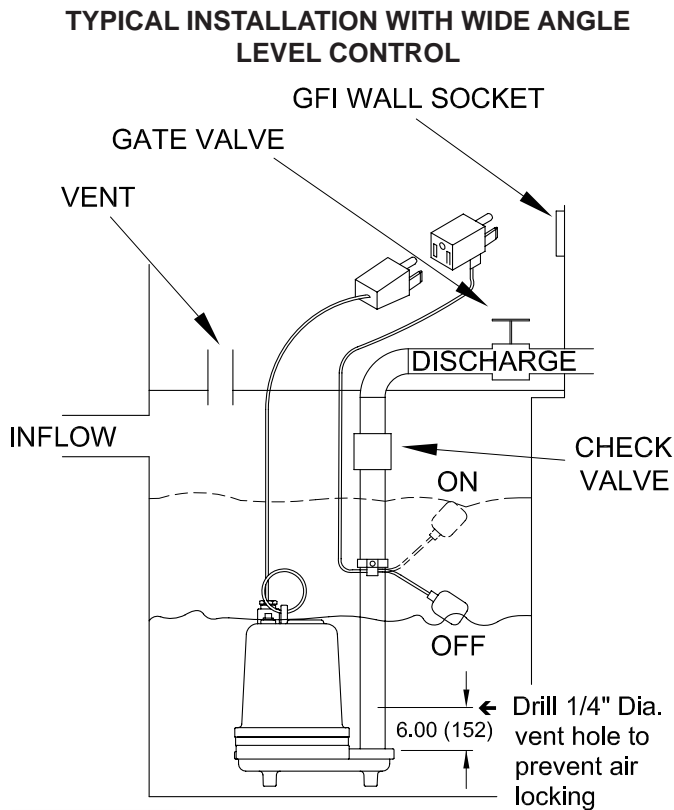

FIGURE 2

General Comments:

- 1) Never work in the sump with the power on.
- 2) Level controls are factory set for a pumping differential of 9 inches. If that is the cycle desired, simply circle the discharge pipe with the pipe mounting strap, feed the end through the worm drive, and tighten with a screwdriver. Be certain that the level control cannot hang up or foul in it's swing. Also, make certain the pump impeller is still submerged when the level control is in the 'off' mode.
- 3) If a higher pump differential is needed, grip the cord near the neck of the float, then using the other hand, exert a steady force on the lower edge of the cable clamp. The cable clamp should slide up to the new pivot point. Attach the level control to the discharge hose in the manner described above.
- 4) Plug the level control plug into the receptacle, then plug the pump into the piggyback plug. One cycle of operation should be observed, so that any potential problems can be corrected.
- 5) It is recommended that the float should be set to insure that the sump well liquid level never drops below the top of the motor housing.
- 6.) Figure 3 shows a typical connection for pumps with the wide angle float and piggy-back plug. For manual and automatic operations.

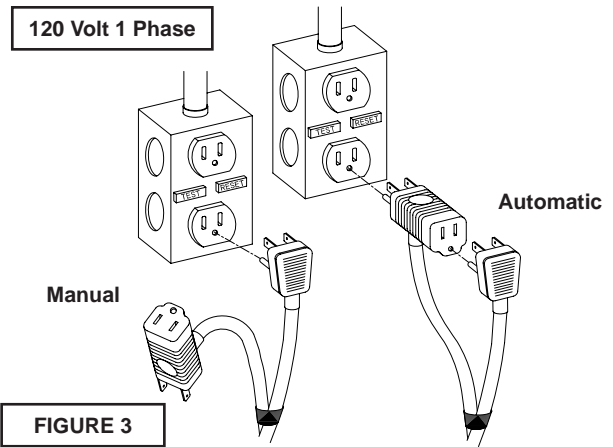

FIGURE 3

- Automatic -** Plug float cord into outlet, then plug pump cord into float cord.
- Manual -** Plug pump cord directly int outlet.

C-4) Electrical Connections:

C-4.1) Power and Control Cable:

The cord assembly mounted to the pump must not be modified in any way except for shortening to a specific application. Any splice between the pump and the control panel must be made in accordance with all applicable electric codes. It is recommended that a junction box, if used, be mounted outside the sump or be of at least Nema 4 (EEMAC-4) construction if located within the wet well. **Do not use the power or control cable to lift pump. NOTE: The white wire is NOT a neutral or ground lead, but a power carrying conductor.**

C-4.2) Overload Protection :

C-4.2-1) Single Phase (Standard) - The type of in-winding overload protector used is referred to as an inherent overheating protector and operates on the combined effect of temperature and current. This means that the overload protector will trip out and shut the pump off if the windings become too hot, or the load current passing through them becomes too high. It will then automatically reset and start the pump up after the motor cools to a safe temperature. In the event of an overload, the source of this condition should be determined and rectified immediately. **DO NOT LET THE PUMP CYCLE OR RUN IF AN OVERLOAD CONDITION OCCURS !**

If current through the temperature sensor exceeds the values listed, an intermediate control circuit relay must be used to reduce the current or the sensor will not work properly.

TEMPERATURE SENSOR ELECTRICAL RATINGS		
Volts	Continuous Amperes	Inrush Amperes
110-120	3.00	30.0
220-240	1.50	15.0
440-480	0.75	7.5
600	0.60	6.0

C-4.3) Wire Size:

Consult a qualified electrician for proper wire size if additional power cord length is required. See table on pages 9 and 10 for electrical information.

MODEL NO	HP	VOLT/PH	Hz	RPM (Nom)	NEMA START CODE	FULL LOAD AMPS	LOCKED ROTOR AMPS	CORD SIZE	CORD TYPE	CORD O.D inch (mm)	WINDING RESISTANCE		
											Emerson Main-Start	Franklin Main-Start	G.E. Main-Start
WE51	0.5	120/1	60	1750	F	11.6	21.3	14/3	SJTOW	0.375 (9.5)			1.51 - 16.10
WE51A	0.5	120/1	60	1750	F	11.6	21.3	14/3	SJTOW	0.375 (9.5)			1.51 - 16.10
WE52	0.5	240/1	60	1750	J	5.9	14.9	14/3	SOW	0.530 (13.5)	3.38 - 9.30		5.69 - 18.74
3WE514L	0.5	120/1	60	1750	F	11.6	21.3	14/3	SJTOW	0.375 (9.5)			1.51 - 16.10
3WE524L	0.5	240/1	60	1750	J	5.9	14.9	14/3	SOW	0.530 (13.5)	3.38 - 9.30		5.69 - 18.74
3WE594L	0.5	200-240/3	60	1750	H/L	3.2/3.0	9.8/11.0	14/4	SOW	0.570 (14.5)	10.20	13.00	
3WE544L	0.5	480/3	60	1750	K	1.5	5.3	14/4	SOW	0.570 (14.5)	40.80	52.00	
3WE554L	0.5	600/3	60	1750	H	1.0	3.4	14/4	SOW	0.570 (14.5)		77.60	89.76
3WE774L	0.75	200-240/1	60	1750	G/K	7.4/7.0	21.5/25.8	14/3	SOW	0.530 (13.5)	1.86 - 10.20		2.74 - 10.56
3WE794L	0.75	200-240/3	60	1750	H/K	4.8/4.5	13.7/15.4	14/4	SOW	0.570 (14.5)		5.49	6.28
3WE744L	0.75	480/3	60	1750	K	2.2	7.7	14/4	SOW	0.570 (14.5)		21.96	24.51
3WE754L	0.75	600/3	60	1750	L	1.5	7.2	14/4	SOW	0.570 (14.5)		34.36	36.60
3WE1074L	1.0	200-240/1	60	1750	D/G	8.8/8.3	21.5/25.8	14/3	SOW	0.530 (13.5)	1.86 - 10.20		2.74 - 10.56
3WE1094L	1.0	200-240/3	60	1750	E/H	5.14/4.9	13.7/15.4	14/3	SOW	0.570 (14.5)		5.49	6.28
3WE1044L	1.0	480/3	60	1750	H	2.4	7.7	14/4	SOW	0.570 (14.5)		21.96	24.51
3WE1054L	1.0	600/3	60	1750	J	1.9	7.2	14/4	SOW	0.570 (14.5)		34.36	36.60

Winding Resistance \pm 5%, measured from terminal block.
Pump rated for operation at \pm 10% voltage at motor.

2" Pumps ONLY:

Mechanical Switch on WE51A, Cable 16/2, SJOW, 0.320 (8.1 mm) O.D. Piggy-Back Plug.

SECTION: D START-UP OPERATION

D-1) Check Voltage and Phase:

Before operating pump, compare the voltage and phase information stamped on the pump identification plate to the available power.

D-2) Check Pump Rotation:

Before putting pump into service for the first time, the motor rotation must be checked. Improper motor rotation can result in poor pump performance and can damage the motor and/or pump. To check the rotation, suspend the pump freely, momentarily apply power and observe the "kickback". "Kickback" should always be in a counter-clockwise direction as viewed from the top of the pump motor housing.

D-2.1) Incorrect Rotation for Three-Phase Pumps:

In the event that the rotation is incorrect for a three-phase installation, interchange any two power cord leads at the control box. **DO NOT** change leads in the cord housing in the motor. Recheck the "kickback" rotation again by momentarily applying power.

D-2.2) Incorrect Rotation for Single-Phase Pumps:

In the unlikely event that the rotation is incorrect for a single phase pump, contact a Weinman Service Center.

D-3) Start-Up Report:

Included at the end of this manual is a start-up report form, this form is to be completed as applicord. Return one copy to Crane Pumps & Systems, Inc., and store a copy in the control panel or with the pump manual if no control panel is used. It is important to record this data at initial start-up since it will be useful to refer to should servicing the pump be required in the future.

D-3.1) Identification Plate:

Record the numbers from the pump identification plate on both START-UP REPORT provided at the end of the manual for future reference.

D-3.2) Insulation Test:

Before the pump is put into service, an insulation (megger) test should be performed on the motor. The resistance values (ohms) as well as the voltage (volts) and current (amps) should be recorded on the start-up report.

D-3.3) Pump-Down Test:

After the pump has been properly wired and lowered into the basin, sump or lift station, it is advisable to check the system by filling with liquid and allowing the pump to operate through its pumping cycle. The time needed to empty the system, or pump-down time along with the volume of water, should be recorded on the start-up report.

SECTION E: PREVENTATIVE MAINTENANCE

As the motor is oil filled, no lubrication or other maintenance is required, and generally will give very reliable service and can be expected to operate for years on normal sewage pumping without failing. However as with any mechanical piece of equipment a preventive maintenance program is recommended and suggested to include the following checks:

- 1) Inspect motor chamber for oil level and contamination and repair as required per section F-1.
- 2) Inspect impeller and body for excessive build-up or clogging and repair as required per section F-2.
- 3) Inspect motor and bearings and replace as required per section F-3.
- 4) Inspect seal for wear or leakage and repair as required per section F-4.

SECTION F: SERVICE AND REPAIR

NOTE: All item numbers in () refer to Figures 15 and 16.

F-1) Lubrication:

Anytime the pump is removed from operation, the cooling oil in the motor housing (5) should be checked visually for oil level and contamination.

F-1.1) Checking Oil:

Motor Housing - To check oil, set unit upright. Remove pipe plug (27) from housing (5). With a flashlight, visually inspect the oil in the motor housing (5) to make sure it is clean and clear, light amber in color and free from suspended particles. Milky white oil indicates the presence of water. Oil level should be just above the motor when pump is in vertical position.

F-1.2) Testing Oil:

- 1.) Place pump on it's side, remove pipe plug (27), from motor housing (5) and drain oil into a clean, dry container.
- 2.) Check oil for contamination using an oil tester with a range to 30 Kilovolts breakdown.
- 3.) If oil is found to be clean and uncontaminated (measuring above 15 KV. breakdown), refill the motor housing as per section F-1.4.
- 4.) If oil is found to be dirty or contaminated (or measures below 15 KV. breakdown), the the pump must be carefully inspected for leaks at the shaft seal (24), cable assembly (13), square ring (23) and pipe plug (27), before refilling with oil. To locate the leak, perform a pressure test as per section F-1.3. After leak is repaired, dispose of old oil properly, and refill with new oil as per section F-1.4.

F-1.3) Pressure Test:

Pumps that have been disassembled, Motor Housing - If the pump has been disassembled, the oil should be drained before a pressure test, as described in section F-1.1. Remove pipe plug (23) from motor housing (5). Apply pipe sealant to pressure gauge assembly and tighten into hole (See Figure 4). Pressurize motor housing to 10 P.S.I. Use soap solution around the sealed areas and inspect joints for "air bubbles".

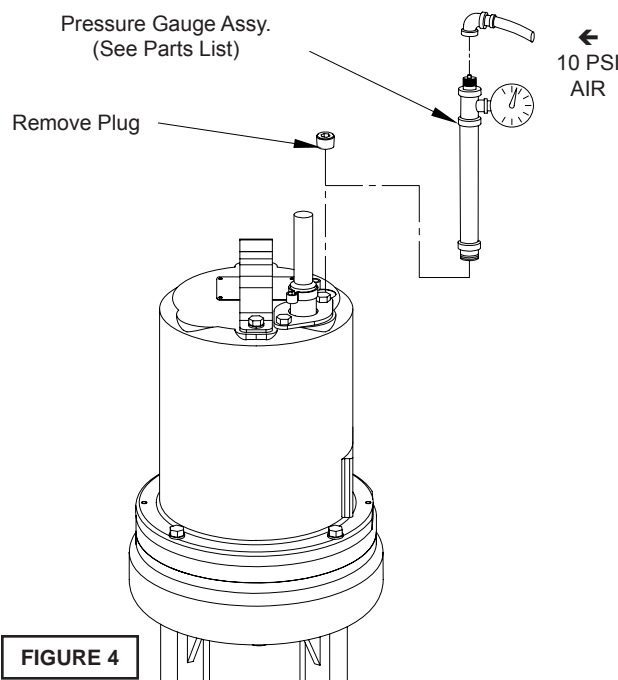

FIGURE 4

If, after five minutes, the pressure is still holding constant, and no "bubbles" are observed, slowly bleed the pressure and remove the gauge assembly. Replace oil as described in section F-1.4. If the pressure does not hold, then the leak must be located and repaired.

Pumps that have NOT been disassembled, Motor Housing

- The pressure test may be done with the oil at its normal level. Remove pipe plug (27) from motor housing (5). Apply pipe sealant to pressure gauge assembly and tighten into hole (see Figure 4). Pressurize motor housing to 10 P.S.I. Use soap solution around the sealed areas above the oil level and inspect joints for "air bubbles". For sealed areas below the oil level, leaks will seep oil.

If, after five minutes, the pressure is still holding constant, and no "bubbles"/oil seepage is observed, slowly bleed the pressure and remove the gauge assembly. If the pressure does not hold, then the leak must be located and repaired.



CAUTION ! - Pressure builds up extremely fast, increase pressure by "TAPPING" air nozzle. Too much pressure will damage seal. DO NOT exceed 10 P.S.I.

F-1.4) Replacing Oil:

Motor Housing- Set unit upright and refill with new cooling oil as per Table 1 (see parts list for amount). Fill to just above motor as an air space must remain in the top of the motor housing to compensate for oil expansion (see Fig 15). Apply pipe thread compound to threads of pipe plug (27) then assemble to motor housing (5).



IMPORTANT! - For single phase units, oil level should be below capacitor.



WARNING ! - DO NOT overfill oil. Overfilling of motor housing with oil can create excessive and dangerous hydraulic pressure which can destroy the pump and create a hazard. Overfilling oil voids warranty.

TABLE 1 - COOLING OIL - Dielectric	
SUPPLIER	GRADE
BP	Enerpar SE100
Conoco	Pale Paraffin 22
Mobile	D.T.E. Oil Light
G & G Oil	Circulating 22
Imperial Oil	Voltesso-35
Shell Canada	Transformer-10
Texaco	Diala-Oil-AX
Woco	Premium 100

F-2) Impeller and Volute Service:

F-2.1) Disassembly and Inspection:

To clean out volute (1) or replace impeller (25), disconnect power, remove hex bolts (22), and lockwashers (11), vertically lift motor and seal plate assembly from volute (1) see Figure 5. Clean out body if necessary. Clean and examine impeller (25), for pitting or wear and replace if required, inspect gasket (26) and replace if cut or damaged. If the impeller (25) needs replacing, place a flat screwdriver in the slot of the end of the shaft to hold the shaft stationary while unscrewing the jam nut (37) and impeller (25).

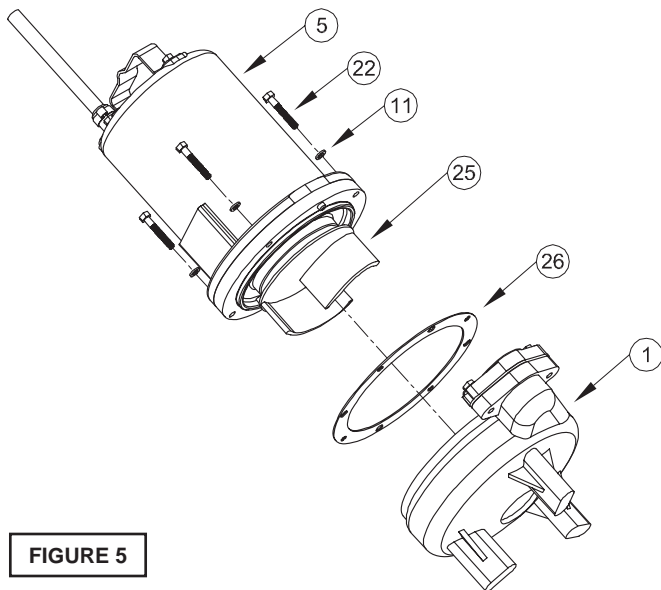

FIGURE 5

F-2.2) Reassembly:

To install impeller (25), clean the threads with thread locking compound cleaner. Apply removable Loctite® 603 or equivalent to shaft threads. Screw impeller onto the shaft hand tight while using a screwdriver in the slot at the end of the shaft to hold it stationary. Apply thread locking compound (34) to shaft threads. Then install jam nut (37) and torque to 40 ft. lbs. It is important that the spring of the lower shaft seal (24) seats in the hub of the impeller (25). Rotate impeller to check for binding. Position gasket (26) on volute flange and position impeller and motor housing on volute (1). Position lockwasher (11) on cap screw (22) and screw into volute (1). Torque to 100 in-lbs. Check for free rotation of motor and impeller.

F-3) Shaft Seal Service:

CAUTION ! - Handle seal parts with extreme care. DO NOT scratch or mar lapped surfaces.

F-3.1) Disassembly and Inspection:

To expose shaft seal (24) for examination, disassemble volute and impeller as outlined in paragraph F-2.1. If further repair is required, remove retaining ring (24d), spring (24c) and rotating member (24b) from shaft (see Figures 6 & 7). Examine all seal parts and especially contact faces. Inspect seal for signs of wear such as uneven wear pattern on stationary members, chips and scratches on either seal face. **DO NOT** interchange seal components, replace the entire shaft seal (24). If replacing seal, remove stationary (24a) by prying out with flat screwdriver.

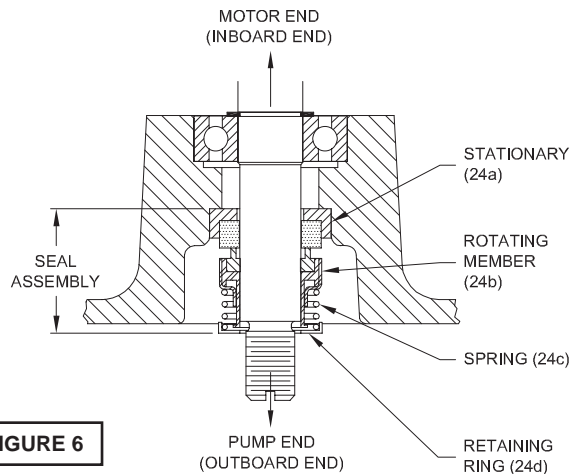

FIGURE 6

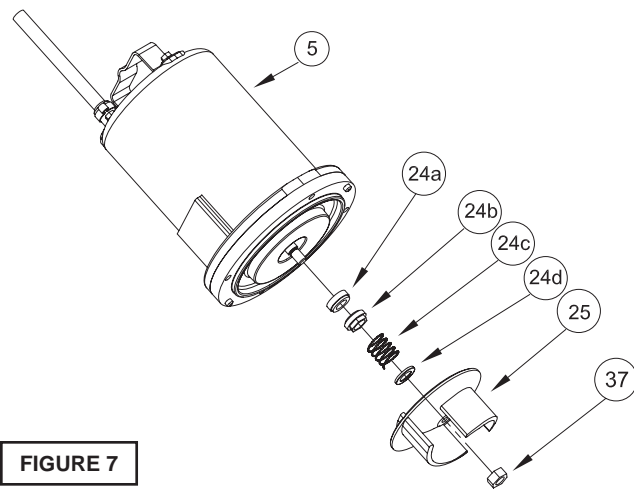

FIGURE 7

F-3.2) Reassembly:

IMPORTANT ! - DO NOT hammer on the seal pusher- it will damage the seal face.

Clean and oil seal cavities in seal plate (4). Lightly oil (**DO NOT use grease**) outer surface of stationary member (24a). Press stationary member (24a) firmly into seal plate (4), using a seal pusher (see parts list - seal tool kit). Nothing but the seal pusher is to come in contact with seal face (see Fig 8). Make sure the stationary member is in straight. Slide a bullet (see parts list - seal tool kit) over motor shaft. Lightly oil (**DO NOT use grease**) shaft, bullet and inner surface of bellows on rotating member (24b) see Figure 9. With lapped surface of rotating member (24b) facing inward toward stationary member, slide rotating member over bullet and onto shaft, using seal pusher, until lapped faces of (24a) and (24b) are together (see Figure 6).

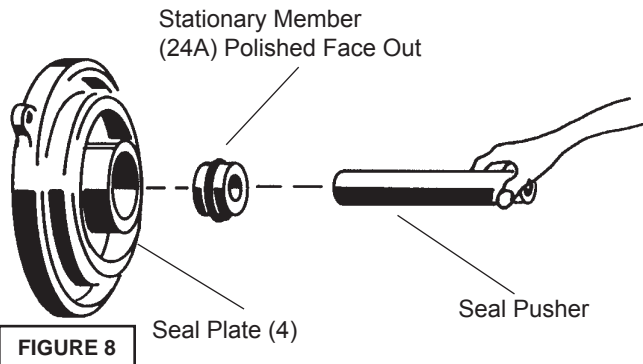

FIGURE 8

It is extremely important to keep seal faces clean during assembly. Dirt particles lodged between these faces will cause the seal to leak. Place spring (24c) over shaft and in place on rotating member (24b), making sure it is seated on retainer and not cocked or resting on bellows tail. Slide retaining ring (24d) over shaft and let rest on spring (24c). Place spring (24c) and retaining ring (24d) onto rotating member (24b). Assemble impeller and volute as outlined in paragraph F-2.2. Replace oil as outlined in paragraph F-1.4.

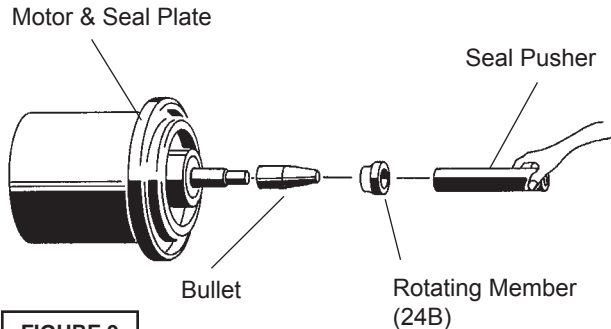

FIGURE 9

F-4) Motor and Bearing Service

F-4.1) Disassembly and Inspection:

To examine or replace the motor (6), capacitor (8, single phase units), and bearing (21), drain oil from motor as outlined in paragraph F-1.1. Disassemble volute and impeller as outlined in paragraph F-2.1 and disassemble shaft seal as outlined in paragraph F-3.1.

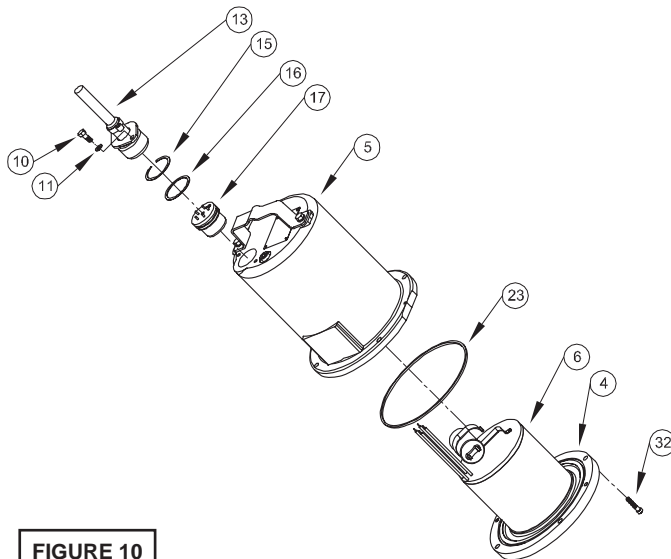

FIGURE 10

Position unit upright, using blocks to avoid resting unit on shaft. Unscrew cable hex bolts (10) and remove compression flange (14) and power cord (13). Remove snap ring (15) with a flat head screwdriver. Pull the terminal block (17) out of the housing (5) using a T-bolt or pair of pliers and a .25-20 screw in the threads of the terminal block (17). Be sure to leave slack on the motor leads connected underneath. Use needle nose pliers to pull each female connector off of the pins on the underside of the terminal block (17) see Figure 11. The unit voltage should be noted. Remove socket head cap screws (32).

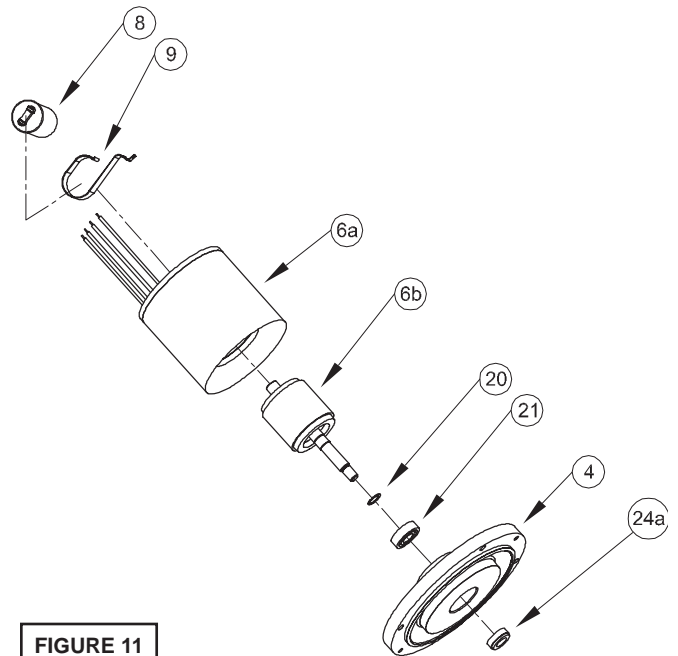

FIGURE 11

Vertically lift the motor housing (5) from seal plate (4) by lifting handle (12). Inspect square ring (23) for damage or cuts. Remove the motor bolts and lift motor stator from seal plate (4). Disconnect capacitor leads from capacitor (8, single phase units). Examine bearing (21) and replace if required. If replacement is required, remove bearing (21) from motor shaft using a wheel puller or arbor press, see Figure 12.

Check motor capacitor (8, single phase units) with an Ohm meter by first grounding the capacitor by placing a screwdriver across both terminals and then removing screwdriver. Connect Ohm meter (set on high scale) to terminals. If needle moves to infinity (∞) then drifts back, the capacitor is good. If needle does not move or moves to infinity (∞) and does not drift back, replace capacitor (8). Inspect motor winding for shorts and check resistance values. Check rotor for wear. If rotor or the stator windings are defective, the complete motor must be replaced.



IMPORTANT! - All parts must be clean before reassembly.

F-4.2) Reassembly:

Bearings - When replacing bearing, be careful not to damage the rotor or shaft threads. Clean the shaft thoroughly. Press bearing (21) on the motor shaft, position squarely onto the shaft applying force to the inner race of the bearing only, until bearing seats against the retaining ring (20) (Included with motor).

Motor - Slide lower bearing (21) and motor shaft squarely into the seal plate (4) until bearing seats on the bottom. Place stator over rotor, lining up motor bolts with holes in seal plate (4). Position capacitor (8, single phase units) so that it will lay on the opposite side of the cable entry boss of the motor housing (5). Reconnect capacitor leads. Torque motor tie bolts to 17 in-lbs. Set square ring (23) in groove on seal plate (4).

F-4.3) Wiring Connections:

Check power cable (13) for cracks or damage and replace if required (see Figure 13). Make internal wiring connections which are independent of the terminal block as shown, using connectors (36) as required. Do not use wire nuts. Slip motor leads and ground wire through fiberglass sleeve. Lower motor housing (5) down onto seal plate (4) while aligning holes and stringing motor leads through the cable entry bore. (Slipping cord inside a 1 ft. length of .5" conduit makes this easier). Place socket head cap screws (32) through seal plate (4) into motor housing (5) and torque to 60 in-lbs. Reconnect motor and leads to the underside of the terminal block (17), as shown in Figure 13. Note that the pins are numbered underneath the terminal block. Place o-ring (16) into groove in terminal block and lubricate with dielectric oil. Press the terminal block (17) into the housing so it seats completely below the snap ring groove. Place snap ring (15) into groove

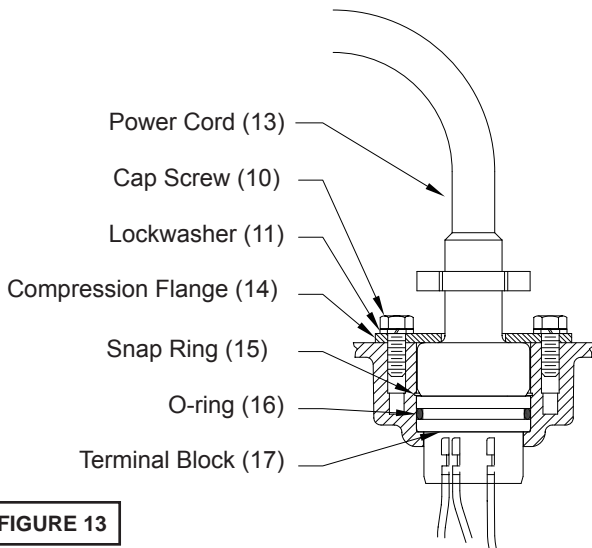

FIGURE 13

in cable entry bore of housing.

F-4.4) Cable Assemblies:

Power/Control Cable - Refill the cooling oil as outlined in paragraph F-1.3. Make wire connections as outlined in paragraph F-4.3. Insert female end of cable plug into housing bore aligning timing mark with hole in terminal block (17) see Figure 14. Compress cable plug with compression flange (14) by tightening hex bolts (01) into the housing (5). Torque

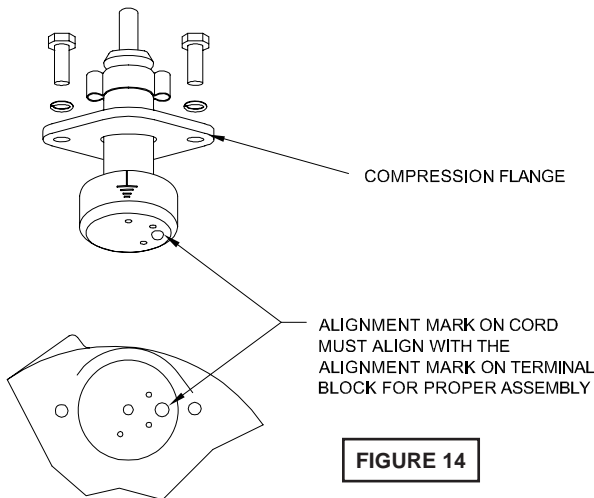

FIGURE 14

to 132 in-lbs.

SECTION: G REPLACEMENT PARTS

G-1 ORDERING REPLACEMENT PARTS:

When ordering replacement parts, ALWAYS furnish the following information:

1. Pump serial number and date code. (Paragraph G-4)
2. Pump model number. (Paragraph G-3)
3. Pump part number. (Paragraph G-2)
4. Part description.
5. Item part number.
6. Quantity required.
7. Shipping instructions.

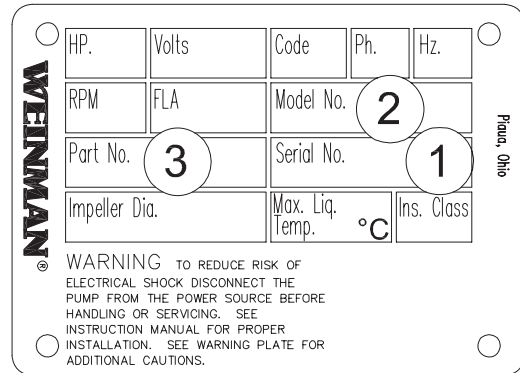

8. Billing Instructions.

G-2 PART NUMBER:

The part number consists of a six (6) digit number, which appears in the catalog. A one or two letter suffix may follow this number to designate the design configuration. This number is used for ordering and obtaining information.

G-3 MODEL NUMBER:

This designation consists of numbers and letters which represent the discharge size, series, horsepower, motor phase and voltage, speed and pump design. This number is used for ordering and obtaining information.

G-4 SERIAL NUMBER:

The serial number block will consist of a six digit number, which is specific to each pump and may be preceded by an alpha character, which indicates the plant location. This number will also be suffixed with a four digit number, which indicates the date the unit was built (Date Code). **EXAMPLE: A012345 0490.**

Reference the six digit portion (Serial Number) of this number when referring to the product.

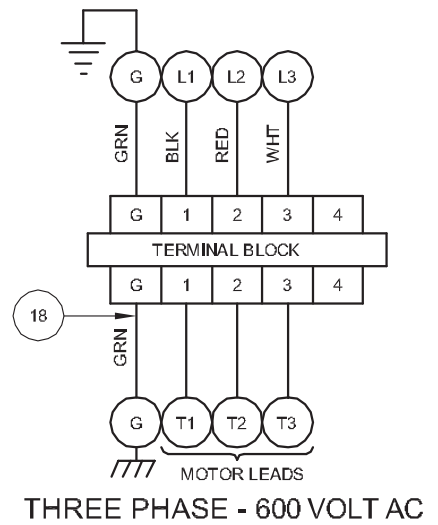
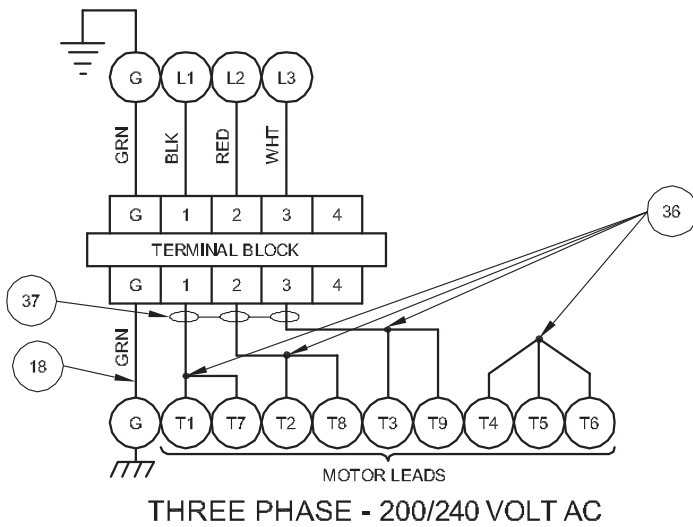
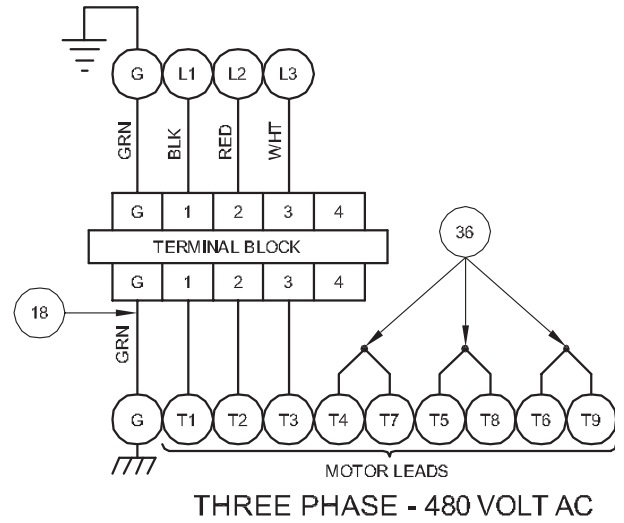
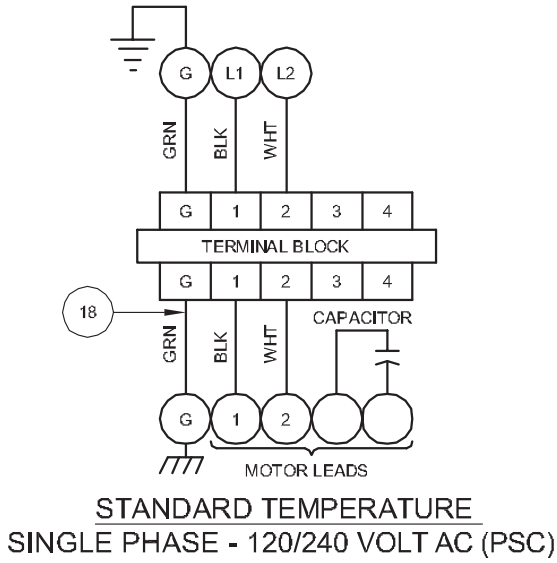

FIGURE 14

TROUBLE SHOOTING

CAUTION ! Always disconnect the pump from the electrical power source before handling.
 If the system fails to operate properly, carefully read instructions and perform maintenance recommendations.
 If operating problems persist, the following chart may be of assistance in identifying and correcting them:
 MATCH "CAUSE" NUMBER WITH CORRELATING "CORRECTION" NUMBER.

NOTE: Not all problems and corrections will apply to each pump model.

PROBLEM	CAUSE	CORRECTION
Pump will not run	<ol style="list-style-type: none"> 1. Poor electrical connection, blown fuse, tripped breaker or other interruption of power, improper power supply. 2. Motor or switch inoperative (to isolate cause, go to manual operation of pump). 2a. Float movement restricted. 2b. Switch will not activate pump or is defective. 3. Insufficient liquid level. 	<ol style="list-style-type: none"> 1. Check all electrical connections for security. Have electrician measure current in motor leads, if current is within $\pm 20\%$ of locked rotor Amps, impeller is probably locked. If current is 0, overload may be tripped. Remove power, allow pump to cool, then recheck current. 2a. Reposition pump or clean basin as required to provide adequate clearance for float. 2b. Disconnect level control. Set ohmmeter for a low range, such as 100 ohms full scale and connect to level control leads. Actuate level control manually and check to see that ohmmeter shows zero ohms for closed switch and full scale for open switch. (Float Switch). 3. Make sure liquid level is at least equal to suggested turn-on point.
Pump will not turn off	<ol style="list-style-type: none"> 2a. Float movement restricted. 2b. Switch will not activate pump or is defective. 4. Excessive inflow or pump not properly sized for application. 9. Pump may be airlocked. 14. H-O-A switch on panel is in "HAND" position 	<ol style="list-style-type: none"> 4. Recheck all sizing calculations to determine proper pump size. 5. Check discharge line for restrictions, including ice if line passes through or into cold areas. 6. Remove and examine check valve for proper installation and freedom of operation. 7. Open valve. 8. Check cutter for freedom of operation, security and condition. Clean cutter and inlet of any obstruction. 9. Loosen union slightly to allow trapped air to escape. Verify that turn-off level of switch is set so that the suction is always flooded. Clean vent hole.
Pump hums but does not run	<ol style="list-style-type: none"> 1. Incorrect voltage 8. Cutter jammed or loose on shaft, worn or damaged, inlet plugged. 	<ol style="list-style-type: none"> 10. Remove & examine for damage. Replace pump stator if required. 11. Repair fixtures as required to eliminate leakage.
Pump delivers insufficient capacity	<ol style="list-style-type: none"> 1. Incorrect voltage. 4. Excessive inflow or pump not properly sized for application. 5. Discharge restricted. 6. Check valve stuck closed or installed backwards. 7. Shut-off valve closed. 8. Cutter jammed or loose on shaft, worn or damaged, inlet plugged. 9. Pump may be airlocked. 10. Pump stator damaged/torn. 	<ol style="list-style-type: none"> 12. Check pump temperature limits & fluid temperature. 13. Replace portion of discharge pipe with flexible connector. 14. Turn to automatic position. 15. Check for leaks around basin inlet and outlets.
Pump cycles too frequently or runs periodically when fixtures are not in use	<ol style="list-style-type: none"> 6. Check valve stuck closed or installed backwards. 11. Fixtures are leaking. 15. Ground water entering basin. 	
Pump shuts off and turns on independent of switch, (trips thermal overload protector). CAUTION! Pump may start unexpectedly. Disconnect power supply.	<ol style="list-style-type: none"> 1. Incorrect voltage. 4. Excessive inflow or pump not properly sized for application. 8. Cutter jammed, loose on shaft, worn or damaged, inlet plugged. 12. Excessive water temperature. 	
Pump operates noisily or vibrates excessively	<ol style="list-style-type: none"> 4. Operating at too high a pressure. 5. Discharge restricted. 8. Cutter broken. 13. Piping attachments to building structure too rigid or too loose. 	

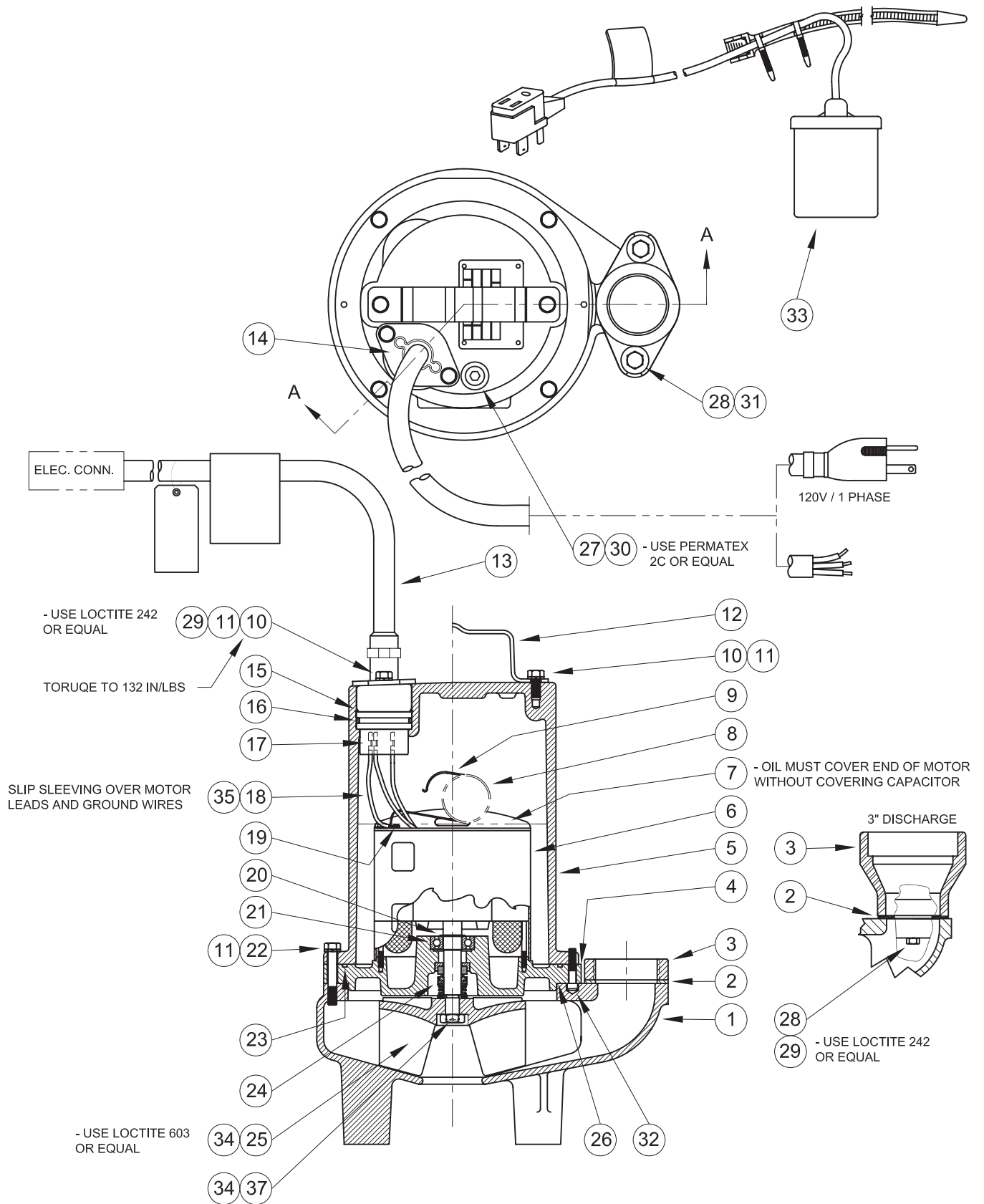

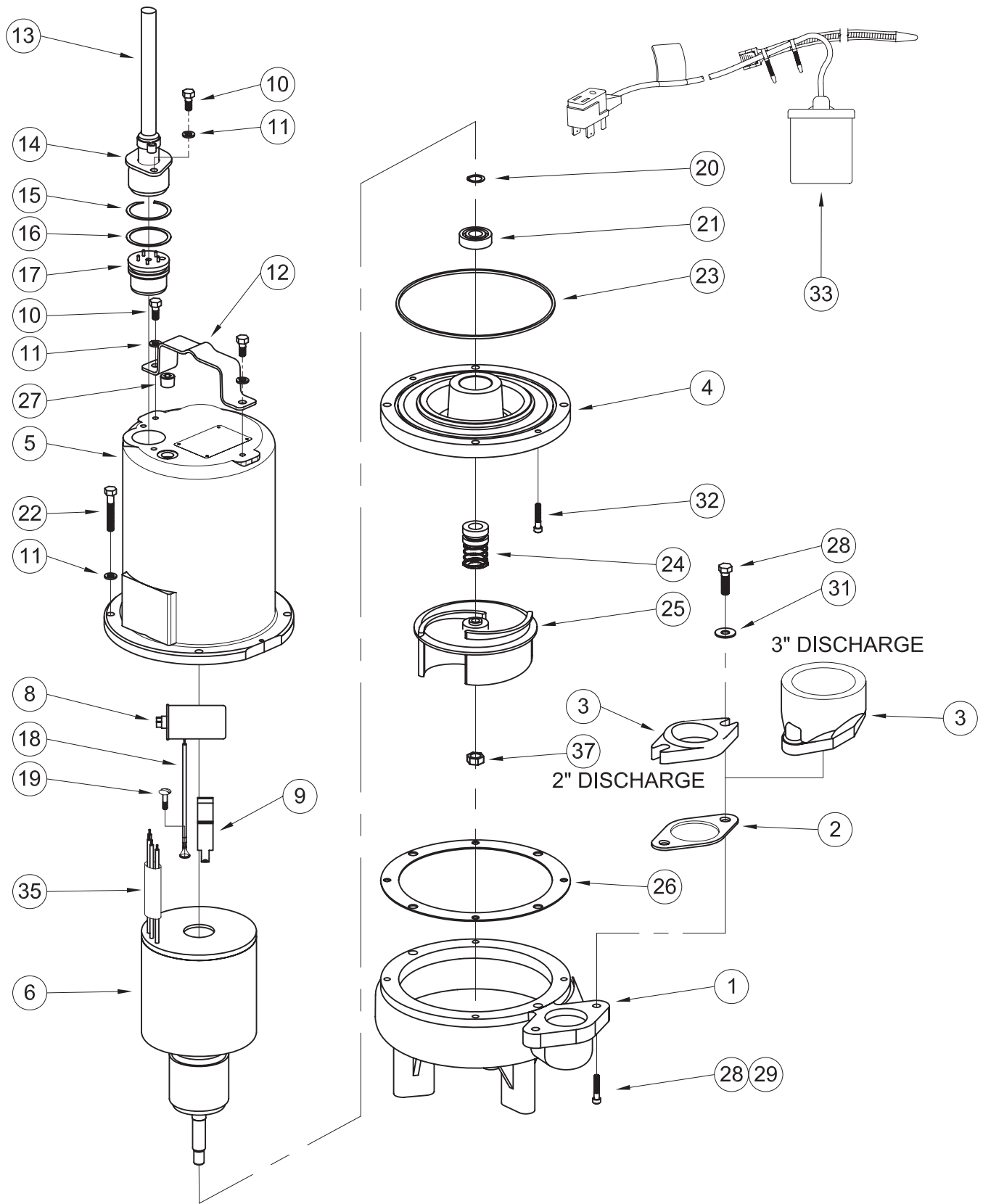

FIGURE 16

PARTS KITS

Seal Repair KitsP/N - 107272 (†) 2, 23, 24, 26

Seal Tool KitP/N - 107271

Pressure Gauge KitP/N - 085343

PARTS LIST

ITEM	QTY.	PART NO.	DESCRIPTION
1	1	055400	Volute
2	1	069140	† Gasket
3	1	026210	Flange
		074498	2" Discharge 3" Discharge
4	1	084532	Seal Plate
5	1	105196	Motor Housing
6	1	Motor:	Capacitor (item 8):
		030369BS	034964 WE51, WE51A, 3WE514L
		030370BS	070963 WE52, 3WE524L
		071352BS	None 3WE594L, 3WE544L
		092854BS	None 3WE554L
		029792BS	070963 3WE724L, 3WE1024L
		071354BS	None 3WE794L, 3WE744L, 3WE1094L, 3WE1044L
		092855BS	None 3WE754L, 3WE1054L
7	96 oz	029034	Oil
8	1	034964*	Capacitor (30MFD) 1 Phase
	1	070963	Capacitor (20 MFD)
9	1	039858	Capacitor Bracket 1 Phase
10	4	1-156-1	Hex. Hd. Cap Screw 5/16-18 x 1.00" Lg., Stainless
11	8	026322	Lockwasher 5/16, Stainless
12	1	103503	Handle
13	1	See Table 2	Power Cable Set
14	1	103582	Compression Flange Included with Cable Set
15	1	105197	Snap Ring
16	1	2-31051-224	O-ring
17	1	103584	Terminal Block 1 Phase
		103583	3 Phase
18	1	105111	Ground Wire Assembly
19	1	016660	Screw, Self Tapping #8-32 x .375" Lg.
20	1	085326	Retaining Ring Included with motor
21	1	017414	Bearing
22	4	1-135-1	Cap Screw 5/16-18 x 1.75" Lg., Stainless
23	1	027269	† Square Ring
24	1		† Shaft Seal
		005080	Carbon/Ceramic/Buna-N (STD)
		005080SB	Tungsten/Tungsten/Buna-N
		005080SD	Silicon Carbide/Silicon Carbide/Buna-N
		005080SF	Carbon/Ceramic/Viton
		005080SH	Tungsten/Tungsten/Viton
		005080SK	Silicon Carbide/Silicon Carbide/Viton
		005080SM	Silicon Carbide/Tungsten/Buna-N
		005080SN	Carbon/Ni-Resistant/Buna-N
		005080SP	Carbon/Ni-Resistant/Neoprene
		082850	Carbon/Ni-Resistant/Viton

* Units with build code date (see section G-4) before -0901 may use capacitor part number, 070963 or the 034964 part number.

25	1			Impeller, Cast Iron	
		084346		6.00 Dia. (STD for 1 HP)	
		084346TA		5.88 Dia.	
		084346TB		5.75 Dia.	
		084346TC		5.63 Dia. (STD for .75 HP)	
		084346TD		5.50 Dia.	
		084346TE		5.38 Dia.	
		084346TF		5.25 Dia. (STD for .5 HP)	
		084346TG		5.13 Dia.	
		084346TH		5.00 Dia.	
		084346TJ		4.88 Dia.	
		084346TK		4.75 Dia.	
		084346TL		4.63 Dia.	
		084346TM		4.50 Dia.	
		084346TN		4.38 Dia.	
		084346TP		4.25 Dia.	
		084346TQ		4.13 Dia.	
		084346TR		4.00 Dia.	
26	1	027344	†	Gasket	
27	1	014270		Pipe Plug	.375" NPT
28	2	1-36-1		Hex. Hd. Cap Screw	2" Discharge, 3/8-16 x 1.25" Lg., Stainless
		1-131-1		Hex. Hd. Cap Screw	3" Discharge, 5/16-18 x 1.25" Lg., Stainless
29	A/R	-----		Loctite 242	
30	A/R	-----		Permatex 2C	
31	2	082727		Washer	2" Discharge, 3/8" Stainless
32	2	084948		Socket Head Cap Screw	1/4-20 x 1.25" Lg., Stainless
33	1	See Table 2		Float Switch w/Plug Piggyback	
34	A/R	-----		Loctite 603	
35	1	625-02117		Sleeve, Fiberglass	
36	3	105150		Terminal Connector	200-240V, 3Ph
	3	625-00163		Terminal Connector	480V, 3PH
37	1	030068		Jam Nut	1/2 - 20, S.S.

TABLE 2 - POWER & SENSOR CORD SETS				
CABLE LENGTH	ITEM #16 240 VOLT 1 PHASE	ITEM #16 240 VOLT 1 PHASE	ITEM #16 3 PHASE	ITEM #55 (OPTIONAL) Piggy-Back Float Switch "A" Series
8 FT	103756A	103741A	103742A	---
15 FT	103756	103741	103742	101758
20 FT (Std)	103756XA	103741XA	103742XA	101758XA
30 FT (Std)	103756XC	103741XC	103742XC	101758XC
50 FT	103756XF	103741XF	103742XF	101758XF
75 FT	103756XJ	103741XJ	103742XJ	
100 FT	103756XL	103741XL	103742XL	

BARNES®

BARNES®
PRESSURE **PS** SYSTEMS



burks®

WEINMAN®

DEMING®

PROSSER®

Limited 24 Month Warranty

Crane Pumps & Systems warrants that products of our manufacture will be free of defects in material and workmanship under normal use and service for twenty-four (24) months after manufacture date, when installed and maintained in accordance with our instructions. This warranty gives you specific legal rights, and there may also be other rights which vary from state to state. In the event the product is covered by the Federal Consumer Product Warranties Law (1) the duration of any implied warranties associated with the product by virtue of said law is limited to the same duration as stated herein, (2) this warranty is a LIMITED WARRANTY, and (3) no claims of any nature whatsoever shall be made against us, until the ultimate consumer, his successor, or assigns, notifies us in writing of the defect, and delivers the product and/or defective part(s) freight prepaid to our factory or nearest authorized service station. Some states do not allow limitations on how long an implied warranty lasts, so the above limitation may not apply. **THE SOLE AND EXCLUSIVE REMEDY FOR BREACH OF ANY AND ALL WARRANTIES WITH RESPECT TO ANY PRODUCT SHALL BE TO REPLACE OR REPAIR AT OUR ELECTION, F.O.B. POINT OF MANUFACTURE OR AUTHORIZED REPAIR STATION, SUCH PRODUCTS AND/OR PARTS AS PROVEN DEFECTIVE. THERE SHALL BE NO FURTHER LIABILITY, WHETHER BASED ON WARRANTY, NEGLIGENCE OR OTHERWISE.** Unless expressly stated otherwise, guarantees in the nature of performance specifications furnished in addition to the foregoing material and workmanship warranties on a product manufactured by us, if any, are subject to laboratory tests corrected for field performance. Any additional guarantees, in the nature of performance specifications must be in writing and such writing must be signed by our authorized representative. Due to inaccuracies in field testing if a conflict arises between the results of field testing conducted by or for user, and laboratory tests corrected for field performance, the latter shall control. **RECOMMENDATIONS FOR SPECIAL APPLICATIONS OR THOSE RESULTING FROM SYSTEMS ANALYSES AND EVALUATIONS WE CONDUCT WILL BE BASED ON OUR BEST AVAILABLE EXPERIENCE AND PUBLISHED INDUSTRY INFORMATION. SUCH RECOMMENDATIONS DO NOT CONSTITUTE A WARRANTY OF SATISFACTORY PERFORMANCE AND NO SUCH WARRANTY IS GIVEN.**

This warranty shall not apply when damage is caused by (a) improper installation, (b) improper voltage (c) lightning (d) excessive sand or other abrasive material (e) scale or corrosion build-up due to excessive chemical content. Any modification of the original equipment will also void the warranty. We will not be responsible for loss, damage or labor cost due to interruption of service caused by defective parts. Neither will we accept charges incurred by others without our prior written approval.

This warranty is void if our inspection reveals the product was used in a manner inconsistent with normal industry practice and/or our specific recommendations. The purchaser is responsible for communication of all necessary information regarding the application and use of the product. **UNDER NO CIRCUMSTANCES WILL WE BE RESPONSIBLE FOR ANY OTHER DIRECT OR CONSEQUENTIAL DAMAGES, INCLUDING BUT NOT LIMITED TO TRAVEL EXPENSES, RENTED EQUIPMENT, OUTSIDE CONTRACTOR FEES, UNAUTHORIZED REPAIR SHOP EXPENSES, LOST PROFITS, LOST INCOME, LABOR CHARGES, DELAYS IN PRODUCTION, IDLE PRODUCTION, WHICH DAMAGES ARE CAUSED BY ANY DEFECTS IN MATERIAL AND/OR WORKMANSHIP AND/OR DAMAGE OR DELAYS IN SHIPMENT. THIS WARRANTY IS EXPRESSLY IN LIEU OF ANY OTHER EXPRESS OR IMPLIED WARRANTY, INCLUDING ANY WARRANTY OF MERCHANTABILITY OR FITNESS FOR A PARTICULAR PURPOSE.**

No rights extended under this warranty shall be assigned to any other person, whether by operation of law or otherwise, without our prior written approval.



A Crane Co. Company

PUMPS & SYSTEMS

420 Third Street
Piqua, Ohio 45356
Phone: (937) 778-8947
Fax: (937) 773-7157
www.cranepumps.com

83 West Drive, Brampton
Ontario, Canada L6T 2J6
Phone: (905) 457-6223
Fax: (905) 457-2650

**IMPORTANT!
WARRANTY REGISTRATION**

Your product is covered by the enclosed Warranty.
To complete the Warranty Registration Form go to:

<http://www.cranepumps.com/ProductRegistration/>

If you have a claim under the provision of the warranty, contact your local
Crane Pumps & Systems, Inc. Distributor.

RETURNED GOODS

**RETURN OF MERCHANDISE REQUIRES A "RETURNED GOODS AUTHORIZATION".
CONTACT YOUR LOCAL CRANE PUMPS & SYSTEMS, INC. DISTRIBUTOR.**



**Products Returned Must Be Cleaned, Sanitized,
Or Decontaminated As Necessary Prior To Shipment,
To Insure That Employees Will Not Be Exposed To Health
Hazards In Handling Said Material. All Applicable Laws
And Regulations Shall Apply.**