



CLEARSTREAM[®]

WASTEWATER SYSTEMS, INC.

P. O. Box 7568 • Beaumont, Texas 77726-7568
(409) 755-1500 • Fax: (409) 755-6500 • www.clearstreamsystems.com

[CLICK ANYWHERE ON THIS PAGE TO RETURN TO AEROBIC
WASTEWATER SYSTEMS INFORMATION at \[InspectApedia.com\]\(http://InspectApedia.com\)](#)

**OWNER'S MANUAL • PARTS LIST • OPERATING MANUAL
FLOW DIAGRAM • INSTALLATION INSTRUCTIONS
DESIGN DRAWINGS AND SPECIFICATIONS
SERVICE POLICY • LIMITED WARRANTY**

MODEL 500N
MODEL 600N
MODEL 750N
MODEL 1000N
MODEL 1500N

500 G.P.D.
600 G.P.D.
750 G.P.D.
1000 G.P.D.
1500 G.P.D.



**CLASS I
ANSI/NSF 40**

INTRODUCTION

The Clearstream System is one of the finest aerobic wastewater systems available today. Our system converts the sewage from your residence or business into a clear, odorless liquid. This high degree of treatment is accomplished at a remarkable low operating cost per month. The system has been simplified over the years to make it as inexpensive to operate and as low in long term maintenance as possible. Homeowners who have lived with the nuisance of a septic odor lingering in their neighborhood will truly appreciate the pleasure of owning a Clearstream System. Clearstream Model N and NC* Systems used without or, in conjunction with, Clearstream Model 1100 Spin Filter comply with NSF Standard 40 for Class I systems.

PROCESS DESCRIPTION

The Clearstream Wastewater Treatment System operates in the extended aeration mode of the activated sludge process.

Wastewater enters the aeration chamber of the system through a 4" Sch. 40 PVC inlet pipe. The wastewater is then mixed throughout the aeration chamber by releasing compressed air near the bottom of the chamber through a fine bubble diffuser. The rising air bubbles transfer oxygen to the wastewater which allows aerobic organisms to thrive and ultimately decompose the incoming waste matter.

The turbulence caused by the rising air bubbles also creates a mixing pattern which keeps the sludge in suspension. As incoming wastewater enters the aeration chamber, existing "mixed liquor" from the aeration chamber is displaced into the bottom of the cone-shaped clarifier.

The clarifier chamber allows the water to still so that suspended solids in the "mixed liquor" can settle back into the aeration chamber for further biological breakdown.

The remaining clear water in the upper zone of the clarifier chamber is then discharged through the surge control weir and out the 4" Sch. 40 outlet pipe.

When properly loaded and maintained, the aforementioned process allows the Clearstream Wastewater Treatment System to provide years of satisfactory service for the consumer. Clearstream Models N and NC* systems meet the performance requirements of NSF Standard 40 Class I with a 30 day average of <25 mg/l CBOD and <30 mg/l TSS. Actual NSF test results used to determine if Clearstream met Standard 40 requirements averaged 6 mg/l BOD and 9 mg/l TSS. When Clearstream Model 1100 Spin Filter Assembly was utilized in the Standard 40 Test the results averaged 5 mg/l BOD and 6 mg/l TSS.

*NC models are concrete

OPERATING MANUAL

In the event you experience a problem with your Clearstream Aerobic Wastewater Treatment System or if service is required, you may reference the Clearstream Control Panel Cover for the name, address and phone number of a local service person that can provide service for your Clearstream Unit. After the expiration of your initial two year service policy provided by the system installer, you may obtain a continuing service policy on a yearly basis which will include terms comparable to the initial service policy from a local service person that is trained and certified by Clearstream.

In order for the Clearstream System to function at optimum performance levels, the system will require periodic service. The normally expected service that is associated with the system includes:

1. Repair or replace aerator	2 to 10 years
2. Clean filters on aerator	6 mos. to 2 years
3. Break up scum in clarifier	6 mos. to 2 years
4. Pump sludge from aeration tank	2 to 5 years*
5. Pump sludge from pretreatment tank	2 to 5 years*
6. Check aeration diffusers	annually
7. Check surge control weir	6 mos.

* Any sludge removed from pretreatment tank or Clearstream Unit must be disposed of according to all state, local, and federal regulatory requirements.

To remove solids from pretreatment tank drop pump hose through access opening on top of tank all the way through to the bottom of the tank. Pump out the whole tank volume, then fill the tank back up immediately. To remove solids from aeration chamber, drop hose through access opening in tank all the way to the bottom of the tank. Pump only 1/2 of the total tank volume and fill tank back up with water immediately.

To determine if all system components are functioning properly, look and/or listen to see if the visual/audio alarm system is illuminated or making a buzzing sound. If the alarm is activated, then either the aerator has thrown its breaker or the high level float inside the clarifier is indicating a high water level condition. Verification of either condition can be made by visually monitoring the push button breaker to see if it is in the out position indicating it has been thrown and opening the access opening to the treatment unit to see if the water level inside the clarifier is at alarm level. After inspection of the clarifier, be sure to securely fasten the access cover back in place and tighten the tamper resistant bolt or bolts firmly.

To determine if the system has the desirable "mixed liquor" and effluent characteristics, first remove the access cover. Monitor for odors coming from the tank. If the odor is a sweet or a musty smell, the system is operating in a desirable aerobic condition. If the odor is foul or smells like a rotten egg, then the system is operating in an undesirable anaerobic condition. Visually monitor the "mixed liquor" for color. If the color is a brownish color, then it is operating in a desirable aerobic condition. If it is grey or black in color, it is operating in an undesirable anaerobic condition. The system effluent should be clear with very few noticeable light brown solids suspended in the effluent. The effluent should not be dark or turbid in color or clear with great numbers of light brown suspended solids noticeable. After inspection of the system's interior, be sure to securely fasten the access cover back in place and tighten the tamper resistant bolt or bolts firmly.

In the event the alarm panel light and buzzer activated, call your local servicing dealer whose name, address, and phone number should be affixed to the face of the panel.

To collect effluent samples from a system, a sample port must be added downstream of the effluent discharge. The sample port should be installed so that effluent cannot remain below the discharge water line and build up solids. A sample bottle should be capable of being lowered into the port on a string and laid on its side in the direct flow line of the discharge and removed when full of effluent.

The expected effluent from the system should be less than 25 mg/l CBOD and less than 30 mg/l TSS with a PH range of 6-9.

For the first two (2) years from the date of installation, your local servicing dealer (from whom you purchased your Clearstream System) will make periodic inspections of your system to make sure it is functioning properly. The dealer will perform necessary maintenance to the system at no charge unless the required maintenance is not warranty related. Pumping of the system is not included. After the first two (2) years, the dealer will offer a continuing service policy for a nominal annual fee. The two (2) year service policy and the continuing service policy are minimum requirements of the NSF International. If local service requirements are greater than those of NSF, or if the local regulations require others to perform the service on these units, Clearstream's limited warranty will still be honored.

For the Clearstream Aerobic Wastewater Treatment Unit to function properly it must be used for the treatment of domestic wastewater from residences or other waste flows with similar loading characteristics. Typical domestic wastewater consists of the flow from toilets, lavatories, sinks, bathtubs/showers, and washing machines. To prevent malfunctions of your Clearstream Unit, the following guidelines should be followed:

1. Any sewage system, whether aerobic or septic, should not have inorganic materials (plastics, cigarette butts, throwaway diapers, feminine napkins, condoms, etc.), that the bacteria cannot consume, discharged into the system.
2. Large amounts of harsh chemicals, oil, grease, high sudsing detergents, discharge from water softeners, disinfectants or any other chemical or substance that kills bacteria should not be discharged into the system.
3. Excessive use of water, over the design flow of the system, or organic overloading in excess of design parameters will cause the system not to perform to its fullest capabilities.
4. The proper operation of this or any other sewage treatment system depends upon the proper organic loading and the life of the micro-organisms inside the system. Clearstream is not responsible for the in-field operation of a system, other than the mechanical and structural workings of the system itself. Field abuse and overloading of the system can only be cured by the user of the system.
5. When wastewater discharge, into a Clearstream Unit, is seasonal or intermittent to a point that the owner wishes to turn off the electricity (for more than three (3) months) to the aerator, the aerator inlet and outlet should be sealed to keep out moisture until the unit is ready to be restarted.

CLEARSTREAM INSTALLATION INSTRUCTIONS

Before installation of the Clearstream Treatment Tank, first install a pretreatment tank (septic tank) with a volume of not less than 50% of the gallon per day rating of the Clearstream Unit. Pretreatment tanks shall comply with minimum sizing specifications outlined in the Clearstream specifications section.

CLEARSTREAM TANK INSTALLATION

1. Prepare an excavation having minimum dimensions of at least one (1) foot larger than the diameter of the tank. Make sure the depth of the excavation is deep enough to allow gravity flow to the inlet of the system and that the excavation bottom is level. Never install the Clearstream tank deeper than a depth that will require more than a maximum of 18 inches of riser depth. The access cover shall always be above final grade after tank installation. In applications where more than the maximum 18 inches of riser is required, install a lift pump upstream of the Clearstream tank in order to pump the pretreatment tank effluent to the Clearstream tank at normal grade. In these special applications where a lift pump is required, contact Clearstream for more details as to pump size, maximum dosages and maximum flow rates.
2. Set the Clearstream tank in a prepared excavation that has a solid, level bottom that will eliminate tank settling. The excavation bottom should have no rocks or sharp objects present.
3. When lowering a fiberglass tank into the prepared excavation use the lifting eyes, which are bolted into the tank top. When lowering a concrete tank into the prepared excavation use a spreader bar or nylon sling. Only spreader bars and other lifting devices, that have been designed and tested for lifting Clearstream concrete tanks, should be used. Never lift fiberglass or concrete Clearstream tanks unless they are empty of all liquids.
4. Make sure the inlet 4" Sch. 40 PVC pipe is aligned properly to incoming sewage line and that the outlet 4" Sch. 40 PVC pipe is aligned to the downstream discharge line. Before setting the tank in the prepared excavation, open the access cover and verify that the inlet and outlet pipes are aligned correctly.
5. For the Clearstream Unit to function properly, the tank must be level. To properly level the tank, remove the access cover and lay a three (3) foot level across the access opening in several directions. Shift the tank in the hole, as necessary, to make the tank level in all directions. The tank may be slightly out of level, but it should not be out of level enough to cause tank malfunctions.
6. Fill the tank with water, checking periodically to make sure the tank remains level.
7. Connect the 4" Sch. 40 PVC Clearstream inlet pipe to the outlet pipe from the pretreatment tank. Make sure the pretreatment tank outlet pipe is level with or higher than the inlet pipe to the Clearstream Unit. The 4" Sch. 40 PVC outlet pipe from the Clearstream Unit should now be connected to the discharge line. The Clearstream Unit should only be connected to a plumbing system from a wastewater source which has been properly trapped and vented in compliance with State and Local plumbing codes.

8. Back fill the excavation in layers with back fill material that will settle properly around the tank. Tamp the back fill material as each layer is placed around the tank. If necessary, use water to help settle the soil around the tank. Special care should be taken to either tamp soil under where inlet and outlet pipes are bridging the excavation or use some other method of supporting pipes across the excavation. Do not back fill with heavy clay or large rocks.
9. Before completing the back fill, be sure the signal wire conduit from the alarm float to the Control Panel has been laid underground.
10. For below normal grade installations a Clearstream 20 inch diameter riser may be used on all models except the 1500 G.P.D. unit. The 1500 G.P.D. unit must use a 32 inch diameter riser. In no case shall more than 12 inches of additional riser depth be used on a single Clearstream Unit to bring the access cover above final grade. All risers must be sealed with silicone to prevent ground water intrusion before back fill is completed.
11. Before leaving excavation site, be sure to securely fasten the Clearstream access cover in place with the tamper resistant bolt(s). Tighten bolts firmly to keep unauthorized personnel from gaining access to the inside of tank.

CLEARSTREAM AERATOR AND CONTROL PANEL INSTALLATION

1. Mount one of the Clearstream Control Panel Model series CS-114 in a location that can be easily noticed by the occupants.
2. Wire 115 Volt, 60Hz power from an electrical disconnect to Clearstream Control Panel. Wire from Control Panel to Aerator and High Level Alarm Float. When discharge pump is used, wire power to pump tank and pump tank alarm float. Use wiring diagram provided for each version of the Clearstream Control Panel Model series. All electrical wiring should be installed by a qualified person in compliance with applicable section of the National Electrical Code or other more stringent local codes.
3. Install Aerator Model CD-103 as close as practical to the tank, but in no case greater than one hundred (100) feet away (50' on 1500 G.P.D. unit). Run 3/4" Sch. 40 PVC air line from aerator connector to air line connection at Clearstream tank. Be careful to back fill underground air line in manner which will not cause air line to leak. Aerator must be installed in a location that is dry, non-dusty, and highly ventilated.
4. Turn power on at electrical disconnect and check for proper system operation.

COMPLIANCE WITH LAWS

The Clearstream Unit must never be installed without first obtaining all permits and approval from the local regulatory body. In areas that do not have local control over environmental activities, all applicable State and Federal environmental codes must be adhered to as well. Only properly licensed and trained individuals should install Clearstream equipment.

DESIGN DRAWINGS

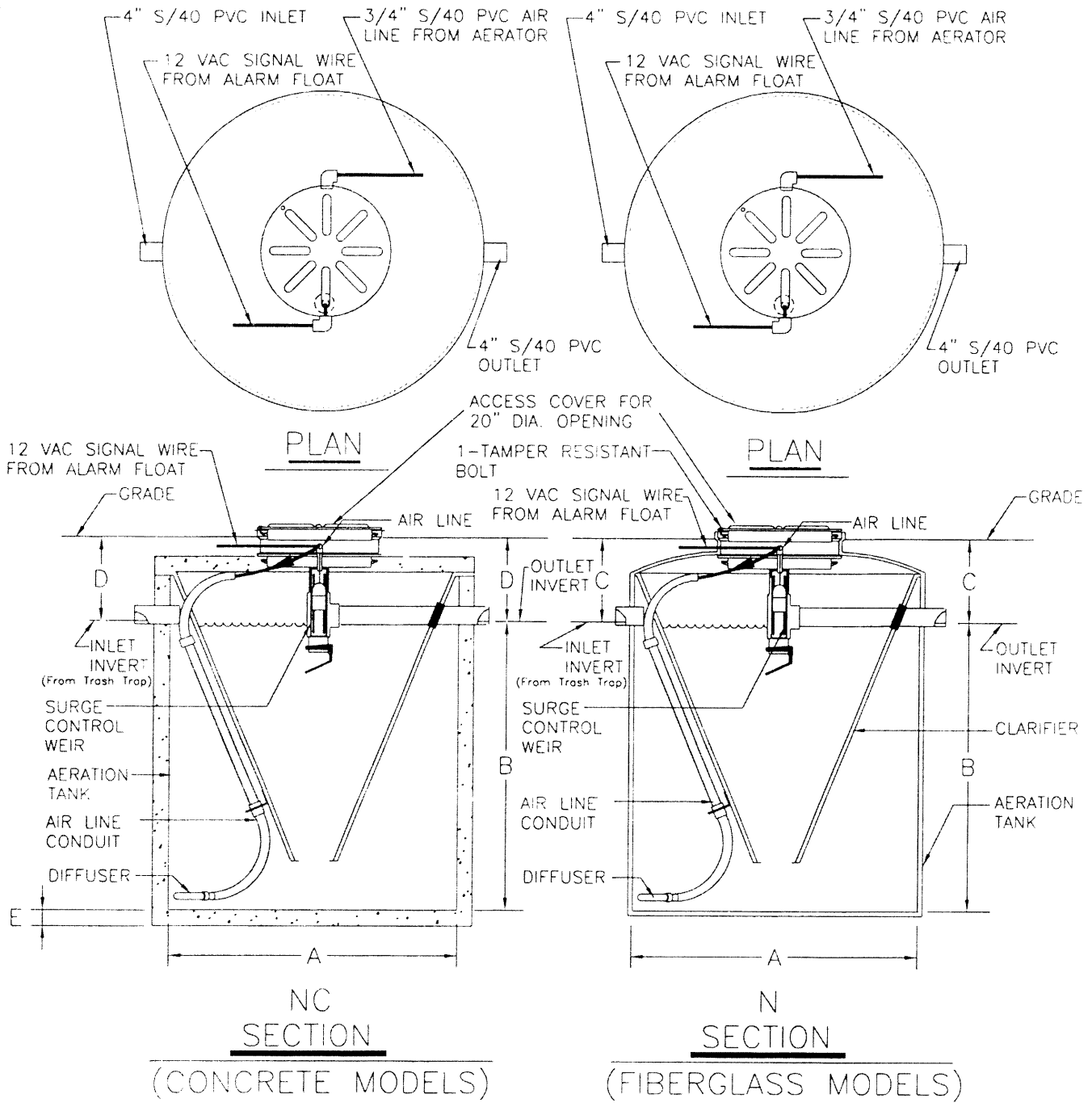

MODEL	A	B	C	D	E
500N/NC	5'-3"	5'-3"	1'-7½"	1'-4¾"	3"
600N/NC	6'-4"	4'-7"	1'-5½"	1'-5¾"	3"
750N/NC	6'-4"	5'-5"	1'-7½"	1'-5¾"	3"
1000N/NC	6'-4"	7'-3"	1'-5¾"	1'-5¾"	3"
1500N/NC	8'-0"	6'-10"	2'-0"	1'-7¾"	4"

U.S. Patent Numbers
 5,221,470
 5,770,081
 5,785,854

SPECIFICATIONS

Clearstream Units

Model 500N

Treatment Capacity	500 G.P.D.
BOD Loading	1.25 lbs. BOD
Aerator (Model CS-103EL)	2.4 scfm
*Aerator (Model CS-103E)	2.4 scfm
Control Panel (Model CS-114A,AP,AT,AN)	Raintight
Electrical	115v./60Hz/.75 amps/82 watts
*Electrical	115v./60Hz/3.8 amps/151 watts

Model 600N

Treatment Capacity	600 G.P.D.
BOD Loading	1.5 lbs. BOD
Aerator (Model CS-103EL)	2.8 scfm
*Aerator (Model CS-103E6)	2.8 scfm
Control Panel (Model CS-114B,BP,BT,BN)	Raintight
Electrical	115v./60Hz/.75 amps/82 watts
*Electrical	115v./60Hz/3.8 amps/157 watts

Model 750N

Treatment Capacity	750 G.P.D.
BOD Loading	1.85 lbs. BOD
Aerator (Model CS-103FL)	3.6 scfm
*Aerator (Model CS-103F)	3.6 scfm
Control Panel (Model CS-114C,CP,CT,CN)	Raintight
Electrical	115v./60Hz/1.05 amps/120 watts
*Electrical	115v./60Hz/4.7 amps/195 watts

Model 1000N

Treatment Capacity	1000 G.P.D.
BOD Loading	2.5 lbs. BOD
Aerator (Model CS-103G)	4.8scfm
Control Panel (Model CS-114D,DP,DT,DN)	Raintight
Electrical	115v./60Hz/4.7 amps/220 watts

Model 1500N

Treatment Capacity	1500 G.P.D.
BOD Loading	3.75 lbs. BOD
Aerator (Model CS-103H)	7.2 scfm
Control Panel (Model CS-114E,EP,ET,EN)	Raintight
Electrical	115v./60Hz/6.58 amps/425 watts

Pretreatment Tank

Minimum Capacity	½ Plant design flow
Minimum Liquid Depth	30 inches
Four Inch Inlet Tee Baffle Discharge	6 inches below liquid level
Four Inch Outlet Tee Baffle Intake	25% to 50% of liquid level
Inlet flow line must be a minimum of two (2) inches higher than the outlet flow line.	

*Alternate aerator option

PARTS LIST AND FLOW DIAGRAM

PART NAME

1. AIR SUPPLY HOSE ASSEMBLY
2. ALARM FLOAT
3. ROTARY VANE AERATOR (OPTIONAL)
4. LINEAR AERATOR
5. EXTERNAL AIR FILTER
6. INTERNAL AIR FILTER
7. TINNEMAN FASTENER (1500N ONLY)
8. FRP 32" DIA. EXTENSION (1500N ONLY)
9. NAMEPLATE
10. ACCESS COVER
11. TAMPER RESISTANT BOLT
12. CHECK VALVE
13. FLOW CONTROL WEIR
14. TANK
15. DIFFUSER
16. ALARM PANEL
17. POLY 20" DIA. EXTENSION

PART NUMBER

- CS-101
- CS-102
- CS-103(E,E6,F,G,H)
- CS-103(EL,FL)
- CS-104
- CS-106
- CS-110
- CS-115
- CS-107
- CS-108
- CS-109
- CS-105
- CS-111(A,B,C,D,E)
- CS-112
- CS-113
- CS-114(A,B,C,D,E)
- CS-116(A,B,C)

COMPONENT PARTS MAY BE OBTAINED FROM:
YOUR LOCAL SERVICING DEALER:

OR

CLEARSTREAM WASTEWATER SYSTEMS, INC.
PO BOX 7568
BEAUMONT, TEXAS 77726-7568
409-755-1500 FAX: 409-755-6500

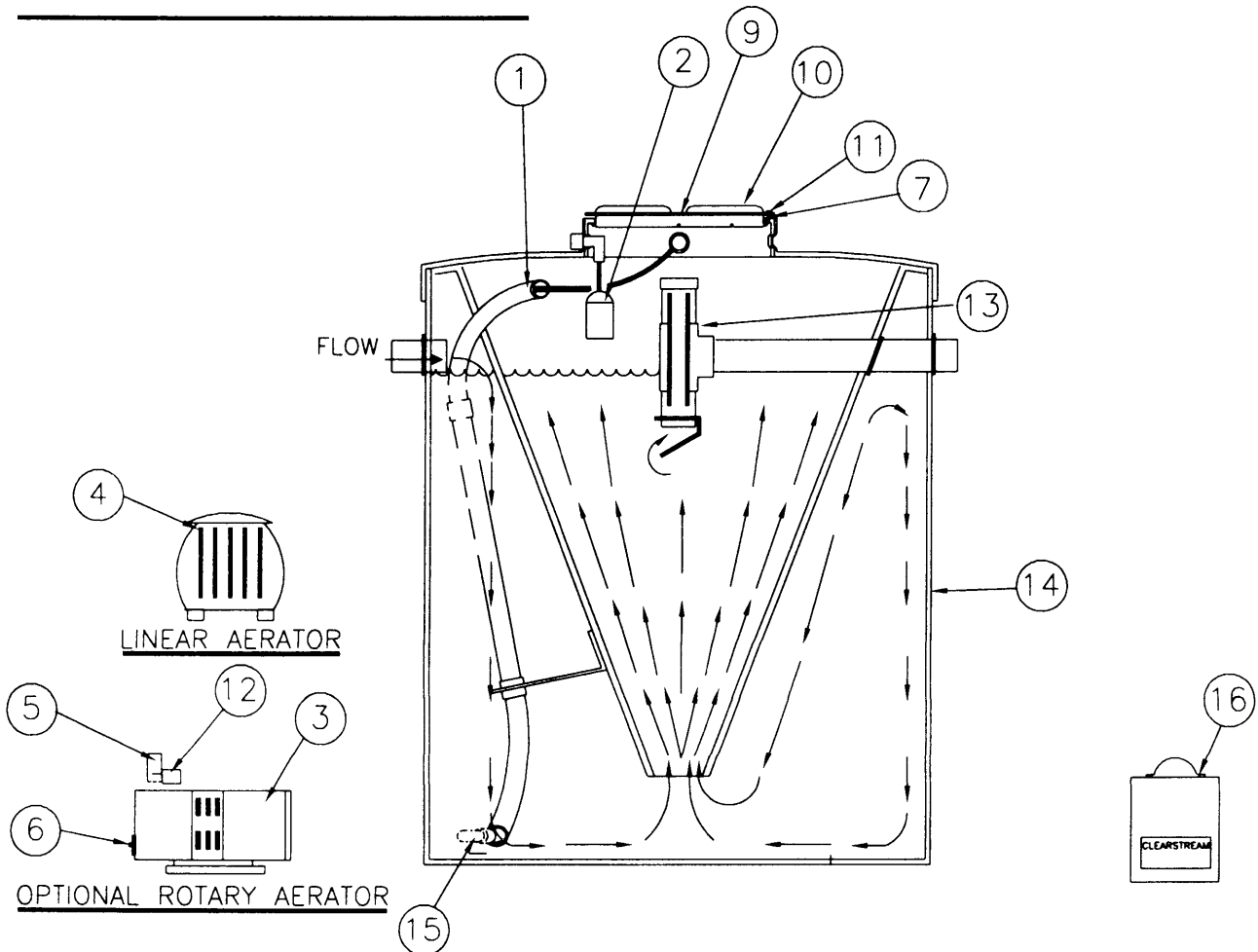

TWO YEAR INITIAL SERVICE POLICY

Date _____

Our firm, _____, will inspect and service your Clearstream System for the first two years from the date of installation. There will be _____ inspections made each year for this initial two year period. Effluent quality inspection will include a visual inspection for color, turbidity, sludge build up, scum overflow, and odor. Mechanical and electrical inspection and service include: inspecting aerator, air filter, and alarm panel and replacing or repairing any component not found to be functioning correctly.

Upon expiration of this policy, our firm will offer a continuing service policy on a yearly basis to cover labor for normal maintenance and repairs on a year by year basis.

Violations of warranty include: shutting off the electric current to the system for more than 24 hours, disconnecting the alarm system, restricting ventilation to the aerator, overloading the system above its rated capacity, or introducing excessive amounts of harmful matter into the system, or any other form of unusual abuse.

THIS POLICY DOES NOT INCLUDE PUMPING
SLUDGE FROM UNIT IF NECESSARY.

Service Dealer:

Owner:

LIMITED WARRANTY

Clearstream Wastewater Systems, Inc. warrants each Clearstream Aerobic Wastewater Treatment System to be free from defects in material and workmanship for a period of two (2) years from the date of sale to the original retail consumer when properly registered with Clearstream. Clearstream's sole obligation under this warranty is as follows: Clearstream shall fulfill this warranty by repairing or exchanging any component part, F.O.B. Factory, that shows evidence of defects, provided said component part has been paid for, warrantee has notified Clearstream of the defect complained of and the component is returned through an authorized Purchaser, transportation prepaid. There is no informal dispute settlement available under this LIMITED WARRANTY.

No warranty is made as to the field performance of any system. This LIMITED WARRANTY applies only to the parts manufactured by Clearstream and does not include any portion of the plumbing, drainage, disposal system, or installation of the systems. Accessories supplied by Clearstream, but manufactured by others, are warranted only to the extent of and by the terms and conditions of the original manufacturer's warranty. In no event shall Clearstream be responsible for delay, or damages of any kind or character resulting from, or caused directly or indirectly by, defective components or materials manufactured by others.

Recommendations for special applications will be based on the best available expertise of Clearstream and published industry information. Such recommendations do not constitute a warranty of satisfactory performance.

The LIMITED WARRANTY extends to the original retail consumer of the product. As herein, "original retail consumer" is defined as the purchaser who first has the plant installed, or in the case of a system designed for non-permanent installation, the purchaser who first uses the system. It is the purchaser's, or any sub-vendee's obligation to make known to any other consumer the terms and conditions of this warranty.

This warranty is a LIMITED WARRANTY and no claim of any nature shall be made against Clearstream unless and until the original retail consumer, or his legal representative, notifies Clearstream in writing of the defect complained of and delivers the product and/or defective part(s), freight prepaid, to Clearstream or an authorized service station.

Clearstream reserves the right to revise, change, or modify the construction and/or design of Clearstream aerobic treatment systems, or any component part or parts thereof, without incurring any obligation to make such changes or modifications in equipment previously sold. Clearstream also reserves the right, in making replacements of component parts under this warranty, to furnish a component which, in its judgment is equivalent to the part replaced.

To the extent that the LIMITED WARRANTY statements herein are inconsistent with the locality where Purchaser uses the Clearstream system, the warranties shall be deemed to be modified consistent with such local law. Under such local law, certain limitations may not apply. For example, some states in the United States and some jurisdictions outside the United States may: (i) preclude the disclaimers and limitations of these warranties from limiting the rights of a consumer; (ii) otherwise restrict the ability of a manufacturer to make such disclaimers or to impose such limitations; or (iii) grant the consumer additional legal rights, specify the duration of implied warranties which the manufacturer cannot disclaim, or prohibit limitations on how long an implied warranty lasts.

In no event and under no legal theory, including without limitation, tort, contract, or strict product liability, shall Clearstream or any of its suppliers be liable to the other party for any indirect, special, incidental, or consequential damages of any kind, including without limitation, damages for loss of goodwill, or any other kind of commercial damage, even if the other party has advised Clearstream of the possibility of such damages.