



ROOFER'S GUIDE TO ROOF INSTALLATION





Dear Owens Corning Roofing Contractor Network Member:

Thank you for your business with Owens Corning. As America's most trusted brand* we take pride in providing homeowners the peace of mind that they have chosen the right roofing system and the right professional contractor for the job. Customers trust their homes and business to Owens Corning Roofing Contractor Network members because they have the confidence in the quality of your work and products you install – all backed by one of the most trusted names in the building materials industry.

To that end, we're pleased to provide you with the new Owens Corning Roofer's Guide to Roof Installation. The purpose of this guide is to provide you with quality instructions and detailed procedures on roof application and product installations following the Asphalt Roofing Manufacturers Association (ARMA) guidelines. This guide is part of Owens Corning Roofing's Quality Assurance Initiative which was carefully developed to enhance our ability to support warranty obligations, improve the overall homeowner experience and achieve accountability across the Owens Corning Roofing Contractor Network for upholding high standards on every job.

Please keep this reference guide handy on the job site as a resource for the correct – and safe – installation of all Owens Corning Roofing products. It is no accident that everything we do begins with safe work conditions.

Thank you,
Quality Assurance Initiative Team



ROOFING FUNDAMENTALS & APPLICATION

	PG #
Roofing Safety	6
Roofing System Inspections	7
Roofing Applications	8-18
Deck Requirements	8
Metal Drip Edge	8
Fastener Requirements	9
Underlayment: Slopes \geq 4:12	11
Underlayment Low Slope: 2:12 < 4:12	12
Ice Dam Protection	13
Valley Constructions	14
Open Valleys	15
Shingle Application	16
Flashing Details	19-24
Flashing against Vertical Sidewalls	19
Flashing around Chimneys	20
Roofing Ventilation	25-27
Proper Ventilation: Intake Low, Exhaust High	25
Roofing Failures	28-30
How to Estimate Roofs	31-35
Installation Instructions: Shingles	36-89
Berkshire®	36-39
Woodmoor®/Woodcrest®	40-44
TruDefinition® Duration® Series	45-49
TruDefinition® Duration STORM®	50-54
TruDefinition® Duration MAX®	55-59
Duration® Premium	60-64
TruDefinition® WeatherGuard® HP	65-69
TruDefinition® FLEX™	70-74
Oakridge®/TruDefinition® Oakridge®	75-79
Supreme®	80-83
2" & 4" Selvage Mineral Surfaced	84-85

	PG #
Installation Instructions: Low Slope	86-91
DeckSeal Low Slope	86-91
Installation Instructions: Components	92-163
Self-Adhered Ice & Water	
WeatherLock® Mat	92-93
WeatherLock® FLEX™	94-95
WeatherLock® G	96-97
WeatherLock® Specialty Tile & Metal	98-99
RhinoRoof® Granulated	100-101
Titanium® PSU30	102-103
Underlayment	
FIBERGLAS™ Reinforced Felt	104
Synthetic Underlayment	
ProArmor®	105-106
Deck Defense®	107-108
RhinoRoof® U20	109
Titanium® UDL25, UDL30 and UDL50	110-112
Starter	
Starter Shingle Roll	113
Starter Strip	114-115
Starter Strip Plus	116-117
Woodstart® Starter	118-119
Hip & Ridge	
DuraRidge® Hip & Ridge	120-121
RIZERidge® Hip & Ridge	122-123
DecoRidge® Hip & Ridge	124
ProEdge® Hip & Ridge	125-126
ProEdge STORM® AR Hip & Ridge	127-128
ProEdge FLEX™	129-130
Berkshire® Hip & Ridge/Berkshire® AR Hip & Ridge	131-132
WeatherGuard® HP Hip & Ridge	133-134

	PG #
Ventilation	
VentSure® 4 ft Strip	135-137
VentSure® 4 Ft Strip with Weather PROtector®	138-140
VentSure® Rigid Roll with Weather PROtector®	141-145
VentSure® Sky Runner LTE®	146-148
VentSure® RidgeCat®	149-151
VentSure® Plastic Slant Back Roof Vent	152-153
VentSure® High Profile Slant Back Roof Vent	154-155
VentSure® Low Profile Slant Back Roof Vent	156-157
VentSure® InFlow® Vent	158-163
Technical Bulletins	164-168
Preventing Damage from Ice Dams	164-165
Decorative Rake Trim as an Alternative to Drip Edge	166
Sidewall and Front Wall Flashing	167
Extended Warranty Coverage	168
Resources	169
Glossary	170-174

ROOFING SAFETY

SAFETY

The best form of accident insurance is accident prevention. It's important to do the following with each new job:

- Inspect each job site before the work begins for possible hazards
 - Overhead electrical lines
 - Unstable ground conditions for ladders or scaffolding
 - Others
- Make sure all workers are aware of any hazards before beginning the job
- Adhere to OSHA safety and fall-protection standards

OSHA

1926.501(b)(10)

- "Roofing work on Low-slope roofs." Except as otherwise provided in paragraph (b) of this section, each employee engaged in roofing activities on low-slope roofs, with unprotected sides and edges 6 feet (1.8 m) or more above lower levels shall be protected from falling by guardrail systems, safety net systems, personal fall arrest systems, or a combination of warning line system and guardrail system, warning line system and safety net system, or warning line system and personal fall arrest system, or warning line system and safety monitoring system. Or, on roofs 50-feet (15.25 m) or less in width (see Appendix A to subpart M of this part), the use of a safety monitoring system

1926.500(a)(1)

- This subpart sets forth requirements and criteria for fall protection in construction workplaces covered under 29 CFR part 1926. Exception: The provisions of this subpart do not apply when employees are making an inspection, investigation, or assessment of workplace conditions prior to the actual start of construction work or after all construction work has been completed.

Safety is everyone's responsibility

- Have a safety plan and checklist and use them
- Create policies and procedures to ensure safe roofing practice
- Help employees know what to do in case of an accident
- Help your roofing business reduce costs by preventing accidents
- Wear footwear that provides good traction such as rubber-soled shoes with good ankle support
- Do not attempt to work in bad weather or on a wet roof
- Do not touch wires crossing over the roof.
- Extension ladders should have proper locking devices and be in good condition
- Place the ladders at safe angles (1 ft out per 4 ft up) on stable foundations
- **Ladders must extend past the edge of the roof by 3' minimum**
- Brace ladders used on the roof deck to the roof structure
- Avoid leaning away from a ladder to work. Move the ladder as required
- As the work proceeds, keep the deck clear of unnecessary debris to avoid tripping hazards
- Always use the proper tools for each segment of the work

ROOFING SYSTEM INSPECTIONS

Remember – Safe roofing is no accident!

- A quality job is dependent on roofing system inspections:
 - Before the job, with the homeowner
 - During the job while installation is in progress
 - After the job is completed – a final walk through with the home owner
- Develop an inspection checklist
- Before the job
 - Inspect the roofing system with the homeowner
 - Document what you see (photos or written notes)
 - Check the roof (measurements, projections, flashings, slope, vents, etc.)
 - Check the attic (sheathing, ventilation, insulation)
 - Rotten wood, stains, mold, rust on nail tips, blocked soffit vents, other vents, bathroom or kitchen exhaust vents properly terminated, insulation type and level, etc.)
 - Check the ceilings (stains, mold, cracking)
 - Check the yard (plants, shrubs, trees, decks, etc.)
 - Prepare your estimate, discuss with owner
- During the job
 - Safety – set-up, ladders, fall protection, etc.
 - Tear-off and waste disposal, cleanliness
 - Roof loading, equipment/tools, hoses, etc
 - Underlayment, measurements, chalk lines, drip edges, starter strips
 - Shingle application, bundle staging, alignment, fastening, hip and ridge caps, vents, etc.
 - Flashing details, use of roofing cements
- After the job, Final Inspection
 - Does the roof look good?
 - Debris cleaned up
 - Roof lays flat (fix “fishmouths”)
 - Replace broken or scuffed shingles
 - Shingles are sealed down
 - Flashings are secure
 - With the homeowner, check out the roof and the grounds – get his/her approval before leaving
 - Photos: Take photos of the finished roof installation for future reference
 - Neighbors: Leave your business cards with the neighbors on either side, across the street and behind the home if appropriate. Offer to have someone return if they should find any debris in their yard from your recent work. This is a goodwill and may lead to future business.

ROOFING APPLICATIONS

DECK REQUIREMENTS

- Minimum 6" width, 25/32" minimum thickness wood sheathing
- Minimum 3/8" plywood sheathing or 7/16" OSB
- Sheathing spaced minimum 1/8" and maximum 1/4"
- Check local building codes

"Sumping" or Deck Deflection (Sag)



METAL DRIP EDGE

2012 International Residential Code (IRC) requires drip edge at the eaves and rake edge of the roof. The IRC has required drip edge since the 2009 edition.

- Apply directly to deck along eave unless otherwise specified by local codes
- Apply over underlayment along rake
- With drip edge—shingles could be flush to edge or overhang 1/4" to 3/4"
- Drip edge is a requirement for Platinum and Preferred Contractor warranties

Drip Edges provide efficient water shedding at the rakes and eaves and protect the underlying wood from rotting. Drip edges should be made of a corrosion-resistant material that extends approximately 3" back from the roof edges and bends downward over the decking. Apply the drip edge underneath the underlayment along the eaves and over the underlayment on the rakes. Figure 3-5 details the placement and fastening of drip edges in combination with underlayment. The use of a drip edge may be required by local building codes.

Figure 1 Application of Drip Edge at Rake and Eaves

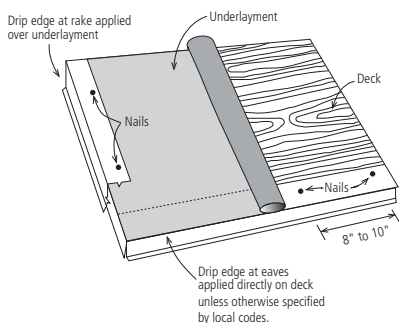

On Rake Edge:

1. All regular underlayments go under the drip edge.
2. When a style D drip edge is used shingles can be flush with the drip edge or overhang by ¼" to ¾".
3. When a starter shingle is used on the rake edge it should also overhang the drip edge ¼" to ¾".

On Eaves:

1. All underlayment goes on top of drip edge unless otherwise specified by local codes.
2. Shingles should overhang the drip edge ¼" to ¾".
3. Shingles can be flush with the drip edge if D style.

Figure 2 Recommended Drip Edge

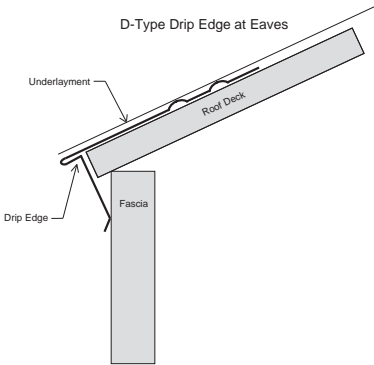
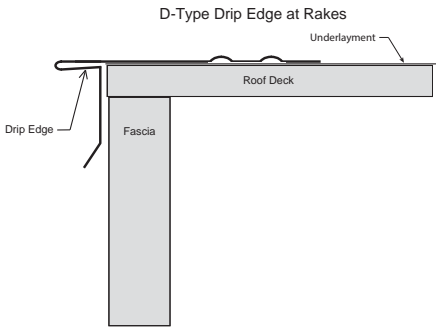

Figure 3 Acceptable Drip Edge



FASTENER REQUIREMENTS

- Use galvanized steel, stainless steel, or aluminum nails with minimum 12 gauge shank and ⅜" diameter head
- Fasteners should comply with ASTM F1667
- Check local building codes.
- Fasteners must penetrate ¾" into wood decking
- Decks less than ¾" thick—fastener must penetrate completely through minimum ⅛"



Figure 4 Fastening

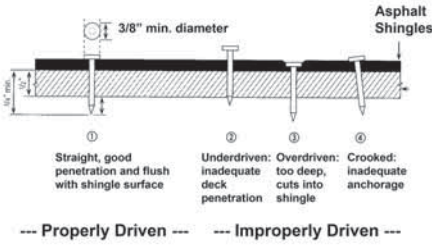

Quantity of Fasteners:

- The number of fasteners as shown in printed installation instructions
- Six fasteners required for mansard-hand sealing is also required
- Check local building codes

Figure 5 Mansard Roof Hand Sealing Example

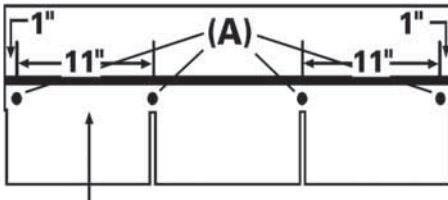
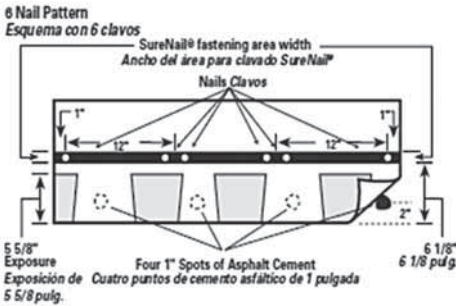

5" Exposure

Figure 6

Oakridge®/Trudefinition® Oakridge® Shingles

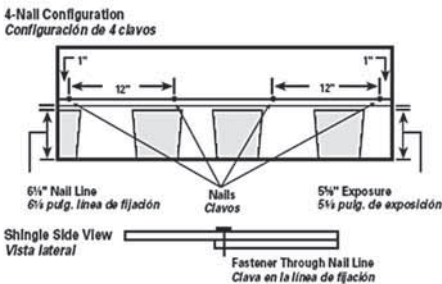
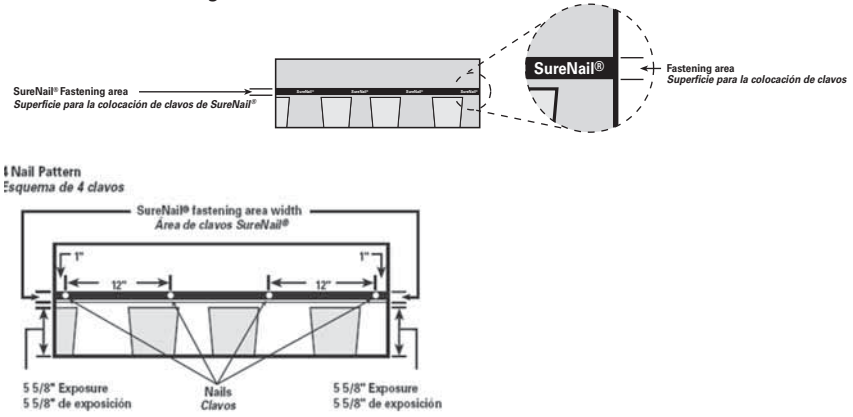

Figure 7

Duration® Series shingles



Shingle Exposure

- Imperial 3 Tab – 5" exposure
- Metric 3 Tab – 5 5/8" exposure
- Laminates - 5 5/8" exposure
- Acceptable tolerance: Plus or minus 1/8"

PROPER UNDERLAYMENT APPLICATION: SLOPES ≥ 4:12

Some building codes have specific requirements for underlayment and/ice dam protection. The requirements of these codes must be followed.

No roof is better than the quality of its installation. Asphalt roofing materials are no exception. They are designed to give years of service when applied carefully and correctly.

Underlayment material used beneath roofing shingles is recommended to comply with one of the following: ASTM D226, ASTM D4869, ASTM D6757, ASTM D1970, or as recommended by the individual shingle manufacturer.

Figure 8

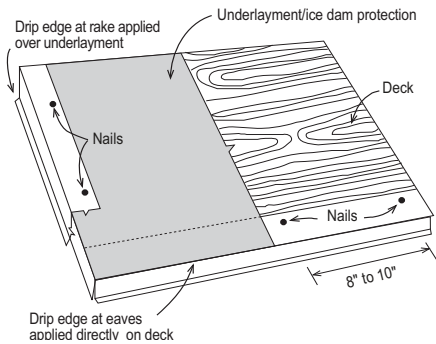
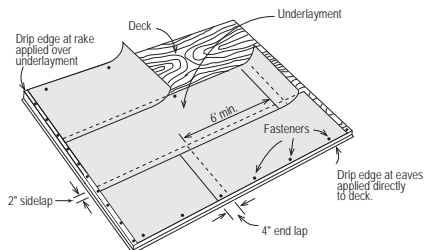

Figure 9 Application of Underlayment or Inclines 4/12" or Greater



UNDERLAYMENT LOW SLOPE: 2:12 < 4:12

Asphalt shingles may be used on slopes ranging from 2"-4" per foot if special procedures are followed. Never use shingles on slopes lower than 2" per foot. Low slopes can lead to problems because water drains slowly from these slopes, creating the greater possibility of water backup and damage from ice dams. The special application method described below for applying shingles on low slopes ensures that the roof remains weather-tight.

Underlayment

On low slope applications, cover the deck with two layers of non-perforated asphalt saturated felt or two layers of a synthetic underlayment. One layer of an appropriate self-adhering modified bitumen membrane can also be used in place of a double layer of felt or synthetic. When using a double layer of felt or synthetic the starter course should be one half of the wide of the underlayment plus 1". Example: a 36" wide roll of felt will have a starter course of 19" while a 48" wide roll of synthetic will have a starter course of 25". Place a full width sheet over the starter, with the long edge placed along the eaves and completely overlapping the initial starter course. All succeeding courses will be a minimum of the full roll wide and should be positioned to overlap the preceding course by one half the roll width plus 1". Secure each course by using only enough fasteners to hold it in place until the shingles are applied. End laps should be 12" wide and located at least 6 feet from end laps in the preceding course. Instructions are different for self-adhering products because they are not required to be installed in two layers.

Figure 10 Application of Underlayment on Low Slopes Where Ice Damming Along the Eaves is Anticipated

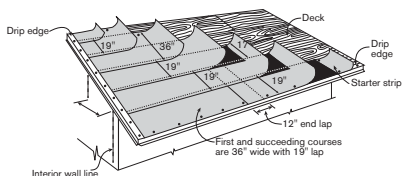
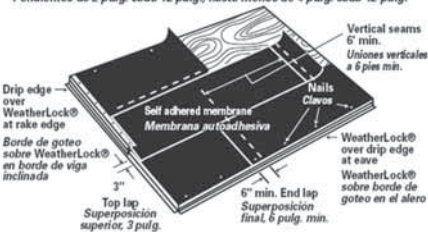

Figure 11 Low Slope WeatherLock® over the entire roof deck

Slopes 2" in 12" to less than 4" in 12"
 Pendientes de 2 pulg. cada 12 pulg., hasta menos de 4 pulg. cada 12 pulg.



One layer of an approved ice and water barrier may be used in lieu of a double layer of felt or synthetic.



ICE DAM PROTECTION

Ice Dams are formed by the continual thawing of snow over the warmer portions of the roof and refreezing over the cold eaves. The ice dams can cause the back up of water and slush under the exposed roofing material and cause damage to the structure. An ice barrier that consists of at least two layers of underlayment cemented together or of a self-adhering polymer modified bitumen sheet shall be used in lieu of normal underlayment and extend from the lowest edge of all roof surfaces to a point at least 24 inches inside the exterior wall line of the building.

Check local building codes. Some local codes may require a distance greater than 24".

Exception: Detached accessory structures that contain no conditioned floor area.

The recommended method is to use self-adhering modified bitumen membrane that complies with ASTM D1970, or as approved by the shingle manufacturer or local code. The self-adhered membrane is applied directly to the deck and is applied at a width to extend up the roof from the eaves or rake edge to a point at least 24" inside the interior wall line (heated space). If the membrane is not wide enough to reach that point, install additional course(s) of membrane as needed, overlapping the previous course by 2" or as specified by manufacturer.

Note: When a self-adhered eave flashing membrane is used as underlayment, no additional eave flashing application is required.

Self-adhered membranes are also excellent for use on ridges, hips, flashings and valleys, as well as around dormers, skylights and chimneys. Because most self-adhering underlayments are vapor retarders, they should not be used beyond recommended areas without proper ventilation. Lack of proper ventilation in these cases will result in the possibility of water vapor condensation under the roof deck.



Figure 12 Application of Self-Adhered Eave and Flashing Membrane

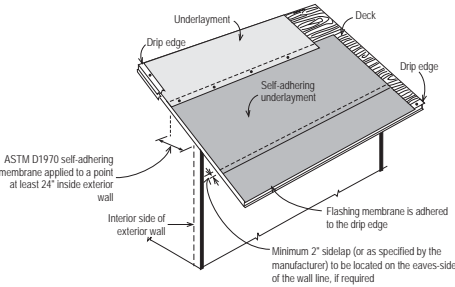
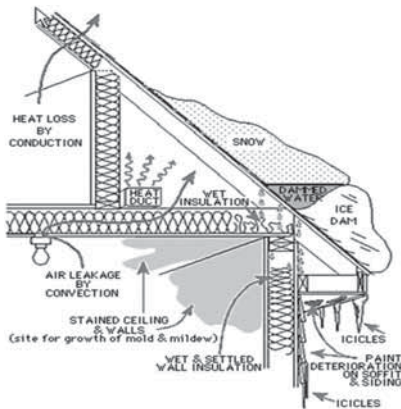

Figure 13 Cross section of a home with an Ice Dam



VALLEY CONSTRUCTIONS

Valleys are formed where two sloping roof planes meet at an angle. The sloping planes direct water toward the valley, concentrating the drainage along the joint and making it especially vulnerable to leakage. As a result, one of the most important installation details for good roof performance is proper valley flashing. Consult the appropriate roofing manufacturers for recommendations on a particular applications

To install underlayment in a valley, first center a 36" wide strip of the appropriate underlayment in the valley and secure it with only enough nails to hold it in place or place a 36" wide strip of self-adhered membrane directly to the deck. Then trim the horizontal courses of felt underlayment applied on the roof to overlap the valley strip at least 6". (See Figure 14). In all valleys the underlayment or self-adhered membrane should be tight in the valley but not creased or wrinkled following application of the underlayment, roofs with multiple planes require the construction of one of four types of valleys: open, woven, no cut or closed out. Regardless of the type of valley used, it must be smooth, unobstructed, of sufficient capacity to carry water away rapidly and capable of withstanding occasional backing up of water.

Following application of the underlayment, roofs with multiple planes require the construction of one of three types of valleys: open, woven or closed cut. Regardless of the type of valley used, it must be smooth, unobstructed, of sufficient capacity to carry water away rapidly and capable of withstanding occasional backing up of water.

Figure 14 Application of Underlayment in a Valley

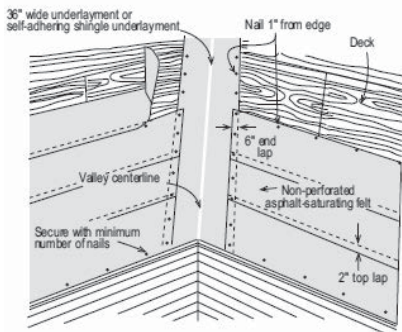

OPEN VALLEYS

The recommended flashing material is a 26-gauge galvanized metal or an equivalent corrosion resistant, non-staining material (check with shingle manufacturer and local code). The width should be no less than 24", but local building codes or shingle manufacturer may require a greater width. (See Figure 15)

Figure 15 Application of Corrosion Resistant Metal Flashing for an Open Valley

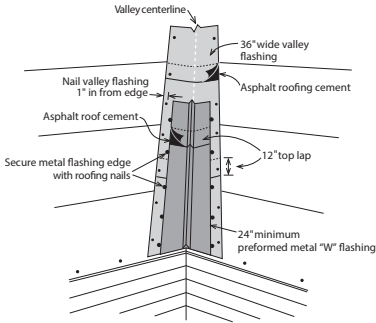
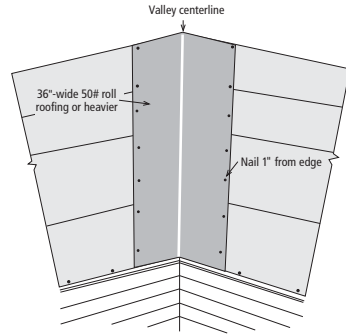

Figure 16 Application of Flashing for a Woven or Closed-Cut Valley



If the valley is covered with a minimum 36" wide self-adhered membrane that complies with ASTM D1970, adhered directly to the deck the valley is ready for the metal valley flashing. If the valley is covered with felt underlayment and additional layer of, #50 or heavier valley underlayment is required before the metal flashing is applied.

Center the strip in the valley, securing the non-self-adhered materials with only enough nails to hold it in place (See Figure 16). Nail the strip along a line 1" from the edges, first on one edge all the way up, then on the other while pressing the flashing strip firmly and smoothly into the valley. Laps should be 12" and cemented.

Center the metal flashing in the valley. Trim the lower edge flush with the eaves drip edge. Install it up the entire length of the valley. If two or more strips of flashing are required, lap the upper piece over the lower so that drainage will be carried over the joint, not into it. The overlap should be 12" and fully bonded with asphalt roofing cement.

Use only enough nails to hold the strip in place. Nail along a line 1" from each edge. Start at one edge and work all the way up. Then return to nail the other side, pressing the flashing strip firmly into the valley at the same time. In areas of heavy rainfall it may be desirable to use a layer of self-adhered eave and flashing membrane (ice dam membrane) beneath the valley and over the initial valley flashing.

After the underlayment has been secured, install the recommended corrosion resistant metal in the valley. Secure the valley metal to the roof deck without puncturing, with roofing nails spaced 8"-12" apart. Overlaps should be 12" and cemented. The valley will be completed with shingle application.

SHINGLE APPLICATION

Starter Strip

Prior to installing shingles a precut starter shingle must be installed. The starter strip protects the roof by filling in the spaces under the shingle joints of the first course of shingles. It should overhang the eaves and rake edges by $\frac{1}{4}$ " to $\frac{3}{4}$ ". Where the drip edge extends out from the eaves and rakes, the shingles may be cut flush with the drip edge with D style drip edge or extend out no more than $\frac{3}{4}$ ".

If self-sealing shingles are used for the starter strip, remove the tab portion of each shingle and position the remaining strip with the factory applied adhesive face up along the eaves. Trim at least 4" [Figure 17 shows 6" removed] from the end of the first shingle in the starter strip. Fasten the starter strips parallel to the eaves along a line $1\frac{1}{2}$ "-3" above the eaves. Position the fasteners so that they will not be exposed under the shingle ends in the first course (See Figure 17).

Figure 17 Application of Starter Strip

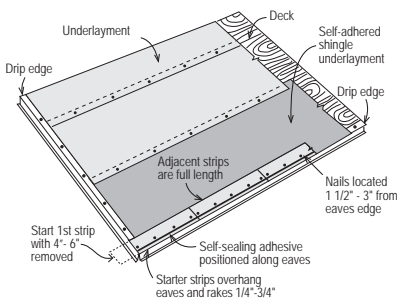

Applying the Shingles

The first course starts with a full shingle, while succeeding courses start with portions removed according to the style of shingle being applied.

By removing different amounts from the first shingle in each course, shingle joints or multiple thickness areas in one course do not line up directly with those of the course below, creating the desired pattern.

Figure 18 - 3 Course Repeat Pattern and Offset

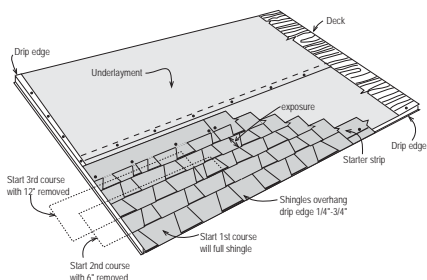

Note: As an alternative method trimming laminates as showing in the figure 18-3 is also acceptable.

Racking



- Installer must work from several bundles of shingles to help reduce shade variation
- Installer must ensure that each shingle has the correct number of nails per the manufactures requirements
- Check local building codes.
- No racking installation premitted for Duration® or Oakridge® shingles

Shading (Racking)



Valleys

Several different methods of treating valleys are possible including the open, no cut and closed cut methods. Open, no cut or closed cut valleys are the preferred method for laminated shingles. Open valleys are preferred for heavy weight and very thick shingles, because of the difficulty in forming the shingles to the valley to make a cosmetically appealing appearance with the woven, no cut or closed cut construction. For all the methods, valley flashing should be in place before shingle application is begun (See page 15) except for open valleys around dormers where the valley flashing must overlap the top courses of shingles along the dormer sidewalls. Thoroughly working all valley materials well into the break of the valley prior to fastening is recommended.

Open Valleys

Snap two chalk lines, one on each side of the valley centerline over the full length of the valley flashing. Locate the upper ends of the chalk lines 6" apart at the ridge (i.e. 3" to either side of the valley centerline). The lower ends of the valley the chalk lines should diverge from each other at a rate of $\frac{1}{8}$ " per foot of valley length. Thus, for an 8' long valley, the chalk lines should be 7" apart at the eaves; for a 16' valley, they should be 8" apart. The minimum shingle overlap on each side of the metal valley is 6". (See Figure 18)

Figure 19 Application of Shingles in an Open Valley

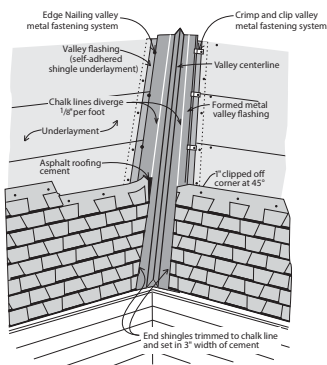

As shingles are applied toward the valley, trim the last shingle in each course to fit on the chalk line. Never use a shingle trimmed to less than 12" in length to finish a course running into a valley. If necessary, trim a section off the adjacent shingle in the course to allow a longer portion to be used. Clip 1" from the upper corner of the shingle on a 45o angle to direct water into the valley and prevent it from penetrating between the courses. Finally, to form a tight seal, cement the shingle to the valley lining with a 3" width of asphalt roofing cement (conforming to ASTM D 4586). There should be no exposed nails along the valley flashing.

Closed Cut Valleys

Note: The first course and only the first course of shingles from the intersecting roof surface should be woven with the first course of shingles on the starting tool.

With valley flashing already in place, apply the first course of shingles along the eaves of one of the intersecting roof planes and across the valley. The first course and only the first course of shingles from the intersecting roof surface should be woven with the first course of shingles on the starting roof. For proper flow of water over the trimmed shingle, always start applying the shingles on the roof plane that has the lower slope or lesser height. Extend the end shingle at least 12" onto the adjoining roof. Do not make a joint in the valley. If a shingle falls short, add in section so that the joint occurs outside the line of the valley. Apply succeeding courses in the same manner, extending them across the valley and onto the adjoining roof. Press the shingles tightly into the valley. Use normal shingle fastening methods except that no fastener should be within 6" of the valley centerline and two fasteners should be placed at the end of each shingle crossing the valley

Figure 20 Shingle application in a closed cut valley

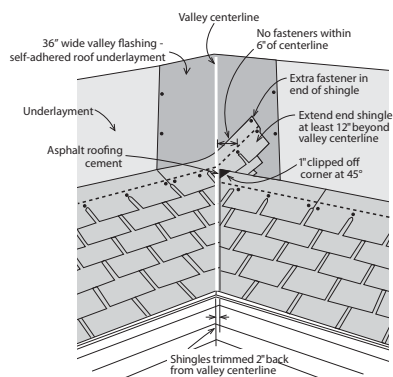
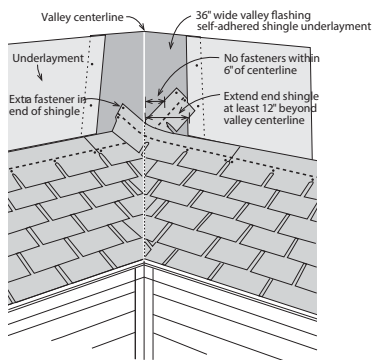

Figure 21 Woven Valley



All

FLASHING DETAILS

areas on the roof surface where there is an intersection of roof planes or a projection through the roof surface (i.e., chimneys, vent stacks, dormer walls, etc.) require “flashing.” Flashing is the construction procedure necessary to make these areas watertight. Careful attention to flashing details is essential for proper leak-free roof performance. Some of the figures showing details may be shown as a strip shingle and/or as a laminated shingle. In most cases the application techniques are identical.

FLASHING AGAINST VERTICAL SIDEWALLS

Roof planes that butt against vertical walls at the end of shingle courses are best protected by metal “flashing shingles” placed over the end of each course. The method is called “step flashing.”

The metal flashing shingles are rectangular, 8” long and 2” wider than the expected exposure of the roofing shingles. For example, when used with laminate shingles 5 $\frac{5}{8}$ ” exposure, they are 8”x4”x4”. The 8” length is to extend 4” and up to 4” above the all surface. Each flashing unit is placed up-roof from the exposed edge of the shingle that will overlap it so that it is not visible when the overlapping shingle is in place. (See Figure 22 & 23)

To install step flashing, place the first flashing unit over the end of the starter strip and position it so that the end shingle in the first course covers it completely. Secure the horizontal flange to the roof with two nails. Do not nail flashing to the wall as differential movement of the wall and roof could damage the seal. Then apply the first course of shingles up to the wall. Position the second step flashing strip over the end shingle in the first course 5 $\frac{5}{8}$ ” up from the butt or the same distance as the shingle exposure so that the end shingle in the second course covers it completely. Fasten the horizontal flange to the roof.

Figures 22 & 23 Application of Step Flashing

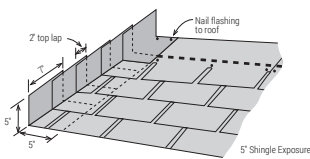

Figure 22

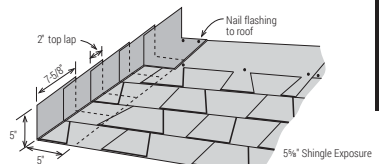
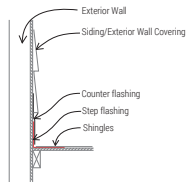

Figure 23

The second course of shingles follows; the end is flashed as in preceding courses and so on to the top of the intersection. Because the metal strip is 8” wide, when the roof shingles are laid with a 5 $\frac{5}{8}$ ” exposure, each flashing unit will overlap the one on the course below by at least 2”.

Bring wall siding down over the vertical sections of the step flashing to serve as counter flashing. Keep wood siding far enough away from the roof shingles so that it may be painted. (See Figure 23)



Figure 24 Application of Step Flashing Against Vertical Sidewall

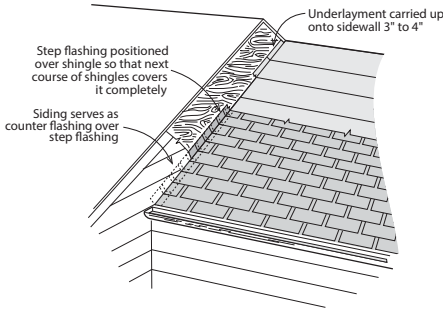

Flashing Against Vertical Front Walls

Apply shingles up the roof until a course must be trimmed to fit at the base of the vertical wall. Apply a continuous piece of metal flashing over the last course of shingles by embedding it in asphalt roof cement and nailing it to the roof. The metal flashing strip should be bent to extend at least 5" up the vertical wall and at least 4" onto the last shingle course. Do not nail the strip to the wall.

Optional method: Apply an additional row of shingles in asphalt roof cement, (conforming to ASTM D 4586) over the metal flashing strip, trimmed to the width of the strip. (See Figure 24)

Figure 25 Application of Flashing Against Vertical Front Wall

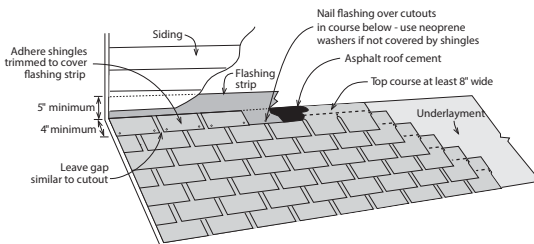

[Caution] Excessive use of asphalt cement may cause blistering.

Bring siding down over the vertical flashing to serve as cap flashing. Keep wood siding far enough away from the roof shingles so that it may be painted. Do not nail siding into the vertical flashing.

If the vertical front wall meets a sidewall, as in dormer construction, cut flashing so that it extends at least 7" around the corner. Then continue up the sidewall with step flashing as described earlier.

FLASHING AROUND CHIMNEYS

To prevent problems that uneven settling can cause, chimneys on older homes were usually built on a separate foundation from that of the main structure. This does not eliminate possible differential settling between the chimney and the main structure. It only frees the chimney from the stresses and distortions that would be imposed on it if both were on the same foundation.

Because of these differential movements, flashings at the point where the chimney projects through the roof calls for a construction that will allow movement without damage to the water seal. To accomplish this, it is necessary to apply apron flashings that are secured to the roof deck and counter flashings that are secured to the masonry. If movement occurs, the counter flashing slides over the apron flashing without affecting water runoff.



NRCA recommends that when a chimney is more than 24" wide a cricket be installed, while the 2015 IRC requires a cricket or saddle be installed on any chimney greater than 30".

Chimneys that project through the roof surface should have a cricket installed at the intersection of the back face of the chimney and the roof deck. The cricket (or wood saddle) is an important element in preserving the integrity of the flashing that will be installed because it prevents the buildup of ice and snow at the rear of the chimney and diverts water runoff around the chimney. (See Figure 26) The cricket should be in place from the start because all roofing materials from the felt underlayment to the roofing shingles are carried over it. If it is not in place, build one as part of the deck preparation prior to applying underlayment and shingles.

Figure 26 Location and Configuration of Chimney Cricket

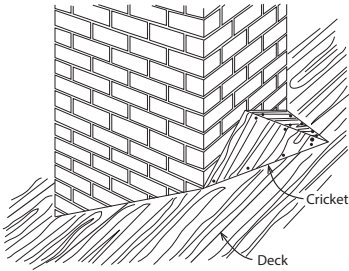

Commonly, a cricket consists of two triangular sections of sheathing supported by appropriate framing members, joined to form a level ridge that extends from the centerline of the chimney back to the roof deck. Nail the sections to the deck and to each other along their meeting edge.

Apply shingles up to the front edge of the chimney before any flashings are installed. In addition, apply a coat of asphaltic masonry primer (conforming to ASTM D 41) to the chimney's brickwork to seal the surface and to provide good adhesion at all points where asphalt roof cement will later be applied.

Begin the flashing construction with the installation of 26-gauge corrosion-resistant metal apron flashing between the chimney and the roof deck on all sides. To provide good adhesion at all points where asphalt roof cement will later be applied.

Figure 27 Pattern for Cutting Front Apron Flashing

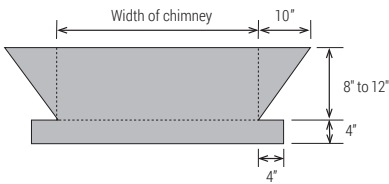

Apply the apron flashing to the front first as shown in Figures 27 and 28. Bend the apron flashing so that the lower section extends at least 4" over the shingles and the upper section extends at least 8" to 12" up the vertical face of the chimney. Work the flashing firmly and smoothly into the joint between the shingles and chimney. Set both the roof and chimney overlaps in asphalt roof cement placed over the shingles and on the chimney face. The flashing may be secured against the chimney with one or two nails driven into the mortar joints to hold it in place until the cement sets.

Figure 28 & 29 Application of Apron & Flashing at Front of Chimney

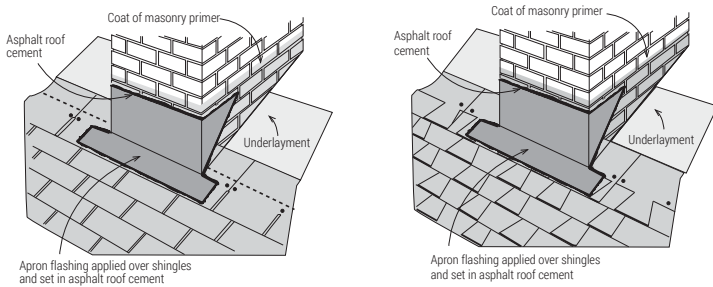

Use metal step flashing for the sides of the chimney, positioning the units in the same manner as flashing a vertical sidewall. Cut, bend and apply the step flashing as shown in Figure 30. Secure each flashing unit to the masonry with asphalt roof cement and to the deck with nails. Embed the end shingles in each course that overlaps the flashing in asphalt roof cement.

Figure 30 Application of Step Flashing at Side of Chimney

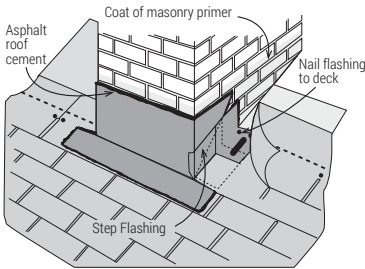

Place the rear cricket flashing over the base and the back of the chimney as shown in Figures 31 through 33. Cut and bend the metal cricket flashing to cover the cricket and extend onto the roof surface at least 6". It should also extend at least 6" up the brickwork and far enough laterally to lap the step flashing on the sides.

Figure 31 Application of corner flashing at rear of chimney

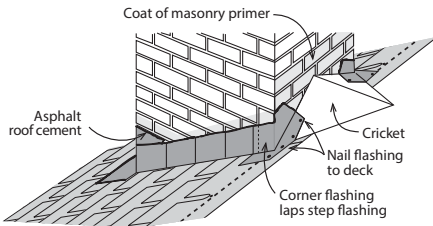
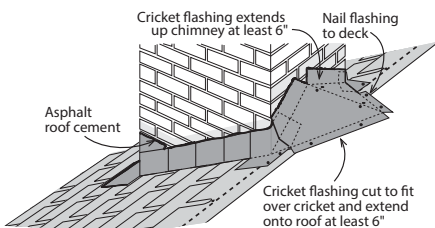
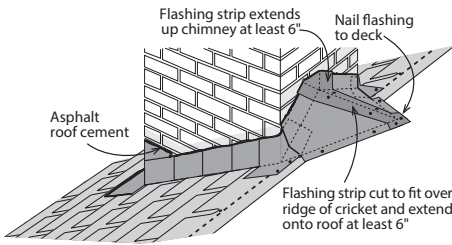

Figure 32 Application of Flashing Over Cricket



If large enough, the base may be covered with shingles. Otherwise, apply the rear apron flashing, bring the end shingles in each course up to the cricket and cement them in place.

Figure 33 Application of Flashing Over Ridge of Cricket



Counter flashings must now be placed over all apron, cricket and step flashings for positive exclusion of water from the joint. Begin by setting the metal counter flashing into the brickwork as shown in Figure 34. This is done by raking out a mortar joint to a depth of 1 1/2" and inserting the bent edge of the flashing into the cleared joint. Once in place and being under a slight amount of spring tension, the flashing cannot be dislodged easily. Refill the joint with Portland cement mortar. Finally, bend the flashing down to cover the flashing and to lie snugly against the masonry.

Figure 34 Application of Counter Flashing

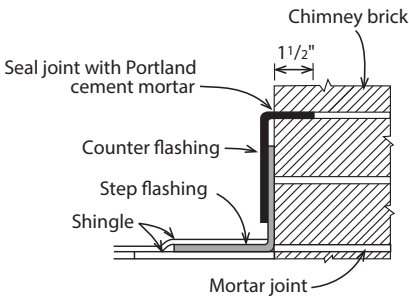

Use one continuous piece of counter flashing on the front of the chimney as shown in Figure 35. On the sides and back of the chimney, use several pieces of similar-sized flashing, trimming each to fit the particular location of brick joint and roof pitch. (See Figure 36)

Start the side units at the lowest point and overlap each at least 3". As this is a metal cricket, it should be left un-shingled in case a leak occurs (a leak would not be readily detectable if the cricket were shingled).

Figure 35 Application of Counter Flashing at Front & Side of Chimney

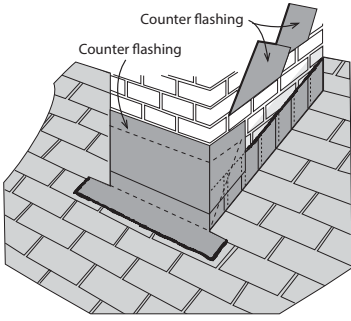

Figures 36 Application of Counter Flashing at Side & Rear of Chimney

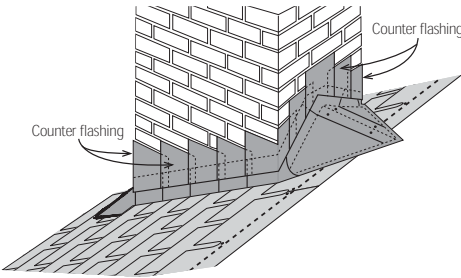

Figures 37 Application of Counter Flashing at Side & Rear of Chimney

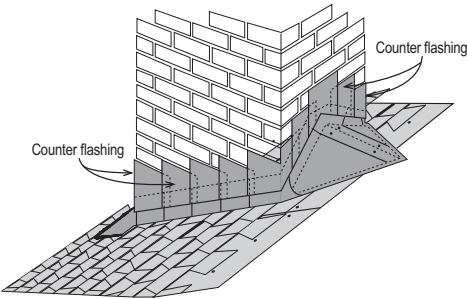

FLASHING DETAILS

ROOFING VENTILATION

Some homes are designed with gable end vents to move air in and out of the attic. In most cases this has been designed by the architect to properly ventilate this structure. If upon attic inspection no preexisting conditions are noted, mold, mildew or damage attributed to improper ventilation then it is advisable not to redesign the homes ventilation. Adding ridge vents to homes with gable vents can cause a ventilation short circuit. If adding ridge vents, soffit vents should also be added, and gable end vents blocked off. Using only ridge vents without proper soffit venting will increase the migration of moist air from the home into the attic.



International Residential Code (IRC)

- Minimum 1 sq. foot NFVA per 150 sq. feet attic floor (1:150 ratio)
- You can reduce ventilation in half (1:300 ratio) under the following conditions:
 - Vapor retarder with a perm of 1 or less OR
 - 50% of required vent area located at the upper portion (at least 3 feet above eave) balance at eave

Determine the Square Footage of the Attic or Area to be Vented (To do this, multiply the width in feet by the length in feet)

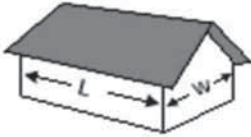

Square Feet

PROPER VENTILATION: INTAKE LOW – EXHAUST HIGH

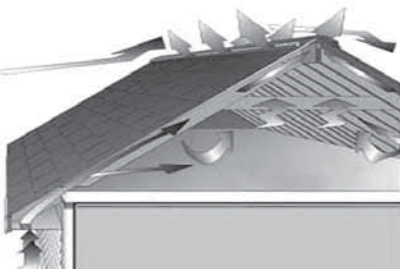

No Ventilation

Traps moisture and heat
Higher energy bills and mold

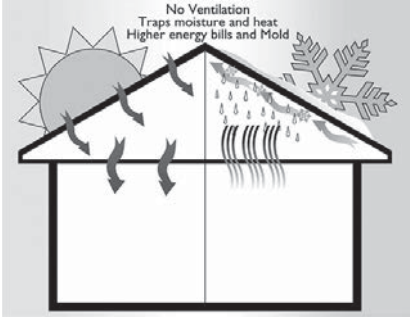

Ventilation

Removes Heat & Moisture

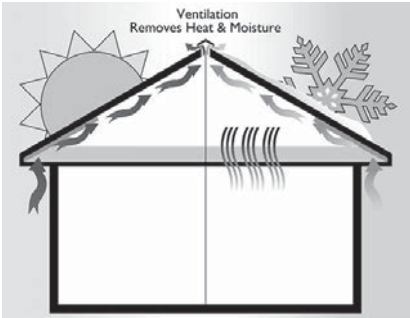

Mold in the Attic

Lack of ventilation



Mold in the Attic

No ventilation or blocked intake - note the frost on the tips of the nails



If a continuous exhaust vent and an equal or slightly greater amount of intake vent is installed, then the attic will be ventilated for its entire length.

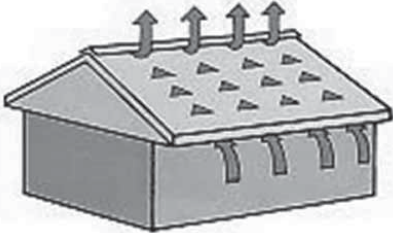

This picture shows what happens if you have no intake vents along the eaves. Air will circulate only between the exhaust vents leaving the remainder of the attic space unventilated.

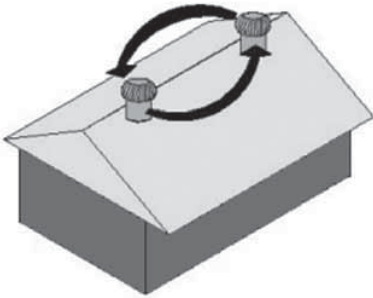

Summary

Your roof protects one of the largest investments you'll ever have, as well as your belongings. It can enhance your home's curb appeal and may also increase its resale value. Most importantly, the roof protects you and your family. So you want to be sure it will last a long time. Remember, if you have any questions about your roof, Owens Corning is always here to help. You can contact us at 1-800-GET-PINK® or through our website at www.owenscorning.com.

ROOFING FAILURES

- Lets look at some example of improper flashing details and workmanship.

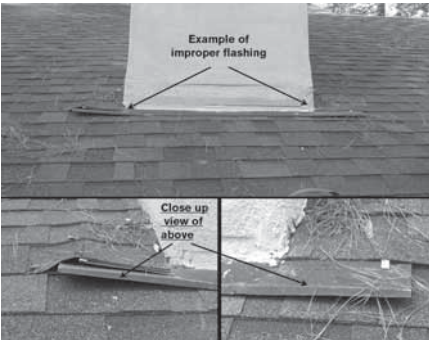
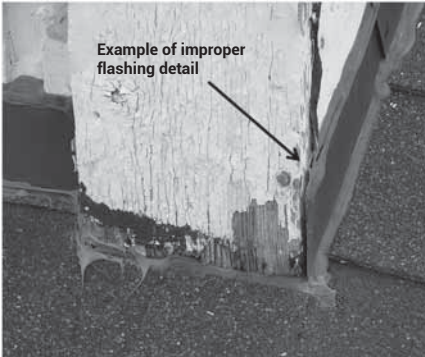

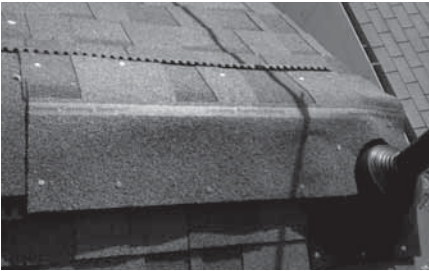
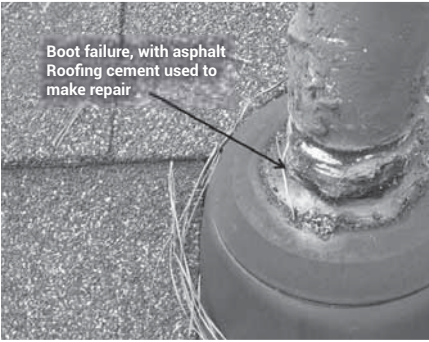

Ridge Vent with pipe coming through the top and then a shingle used for the ridge cap



Blocked Intake

Notice how mold is starting to grow on the underside of the roof deck



Vent Pipe

The vent pipe is disconnected in the attic allowing moist air to be exhausted in the attic area

ESTIMATING HOW MUCH ROOFING IS REQUIRED

Various types of asphalt roofing materials and accessories are required to complete a typical roofing job including shingles or roll roofing, underlayment, starter strips, drip edges, valley flashings and hip and ridge shingles. Before the job begins, estimates of the required quantities of each material, based on calculations derived from the dimensions of the roof, must be made.

Fairly simple calculations are all that are required. Certain measurement and calculation methods also may be used that simplify the process even further. These are described in the following sections along with suggestions on how to take measurements.

Note: The most accurate method to measure a roof is from up on the roof. Taking these measurements should be done by a roofing professional. It is not recommended that homeowners climb up on a roof to take these measurements. If a homeowner wants to estimate the size of their roof from the ground there are various resources available on the Internet that can provide assistance.

Estimating Area (Simple Roofs)

Roofs come in a variety of shapes and styles but virtually every kind of roof is comprised of plane surfaces that can be subdivided into simple geometric shapes — squares, rectangles, trapezoids and triangles. Thus, roofing area calculations simplify to area calculations for these basic shapes.

The simplest type of roof is one without any projecting dormers or intersecting wings. Each of the illustrated roofs is comprised of one or more rectangles. (See Figure 38) The area of the entire roof in each case is the sum of the areas of each rectangle.

Figure 38 Examples of simple roofs

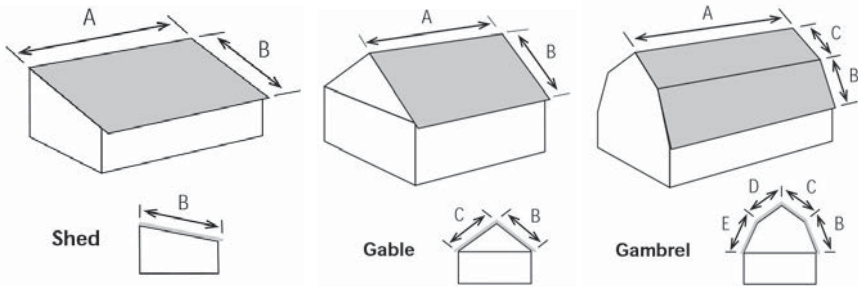

For the shed roof which has only one rectangle, the area is found by simply multiplying the rake line by the eaves line, or $B \times A$. The gable roof is comprised of two rectangular planes and its area is found by multiplying the sum of the rake lines by the eave line, or $A(B + C)$. For the gambrel roof, four rake lines are involved and the total area calculation is found by multiplying the sum of the rake lines by the eave line, or $A(B + C + D + E)$.

Estimating Area (Complex Roofs)

The more complex roofs include those with intersecting wings or dormer projections through the various roof planes. Area calculations for these roofs use the same basic approach taken for simple roofs but involve a number of subdivisions of the roof surface that are calculated separately, then added together to obtain the total roof area.

If plans of the building are available, use them to obtain the required roof dimensions from which area calculations can be made. Otherwise, direct measurements may have to be taken on the roof.

There are many ways in which to calculate the area of a roof. This section will demonstrate one method of how to do it properly. The final answer will be in "squares", the unit of area measurement used in roofing.

1 square = 100 square feet

Some simple geometry is required to use this method.

The base length (b) times the height (h) of any triangle is twice its area (A). So if you divide the product of the base and height by two, then you have the area of a triangle.

$(b \times h) / 2 = \text{Area of a triangle}$

Although the following two triangles, R and H, look different from each other, they in fact have exactly the same area.

$(20' \times 20') / 2 = 200 \text{ square feet}$

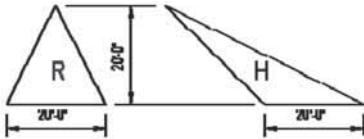

The picture below represents an aerial view of a roof with one hip end and three gable ends. It is strongly recommended that you make a rough sketch of your roof. In order to make it easier for measuring, the roof sketch has been broken up into sections A through F. These sections show the plan view (top looking down) shown in a flat layout even though the roof is not flat.

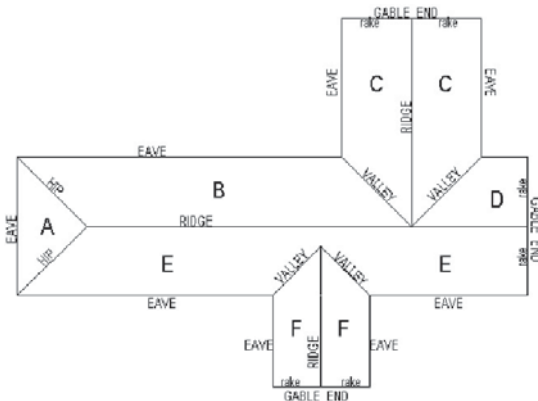

Section A

Section A is a simple triangle. Measure the length of the eave and the perpendicular line from the eave to the peak. Multiply these numbers and divide the answer by two.

$(30' \times 15') / 2 = 225 \text{ square feet}$

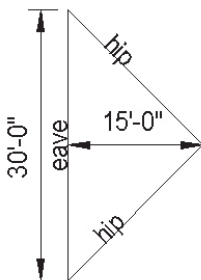

So **Section A** has 225 square feet in it.

Section B

Measure this section by dividing it up into three different sections: x, y, and z. Sections x and z appear to be the same size. However it is a good idea to measure both triangles.

$$x = (15' \times 15')/2 = 112.5 \text{ square feet}$$

$$y = 55' \times 15' = 825 \text{ square feet}$$

Add another 112.5 square feet to our current list of numbers, since z has been determined to be equal to x after measuring.

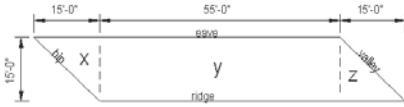

So **Section B** has a total of $112.5 + 112.5 + 825 = 1,050$ square feet.

Section C

As with **section B**, **section C** appears to have symmetrical sides. Divide it up into sections. A quick measurement verifies that x and z are the same as w and y, therefore multiply the sum of w and y by 2 for the final Area.

$$w = 30' \times 15' = 450 \text{ square feet}$$

$$y = (15' \times 15')/2 = 112.5 \text{ square feet}$$

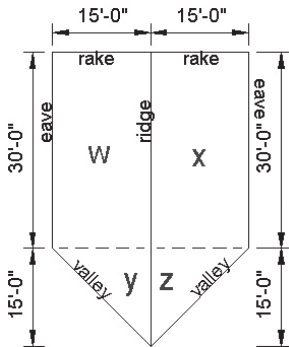

Section C = $(450 + 112.5) \times 2 = 1,125$ square feet.

Section D

$$x = (15' \times 15')/2 = 112.5 \text{ square feet}$$

$$y = 10' \times 15' = 150 \text{ square feet}$$

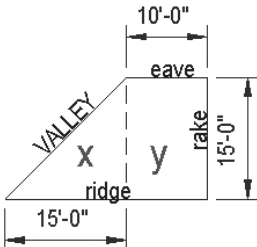

Section D = $112.5 + 150 = 262.5$ square feet

Section E

Because this section has several different subsections, it is important to double check the measurements in the sketch and to make sure that every piece is either rectangular or triangular.

$$s = (15' \times 15')/2 = 112.5 \text{ square feet}$$

$$t = 40' \times 15' = 600 \text{ square feet}$$

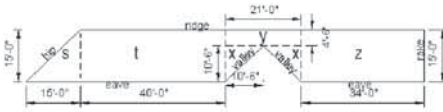

Both small triangles in the center part should be checked to make sure that they are the same size.

$$x = (10.5' \times 10.5')/2 = 55 \text{ square feet}$$

$$y = 21' \times 4.5' = 94.5 \text{ square feet}$$

The actual answer of x is $55\frac{1}{2}$ square feet, but it has been rounded off for ease of measuring.

$$z = 34' \times 15' = 510 \text{ square feet}$$

Section E = $112.5 + 600 + 55 + 55 + 94.5 + 510 = 1,427$ square feet.

Section F

This section is a smaller version of **Section C** and should be calculated the same way.

$$w = (10.5' \times 10.5')/2 = 55 \text{ square feet}$$

$$y = 20' \times 10.5' = 210 \text{ square feet}$$

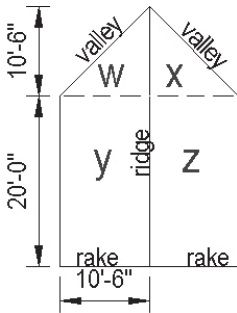

Section F = $55 + 55 + 210 + 210 = 530$ square feet.

Sum It Up

Adding up the subtotals from all sections:

Section A	= 225
Section B	= 1,050
Section C	= 1,125
Section D	= 262.5
Section E	= 1427
Section F	= 530

Total square footage is equal to 4,619.5 square feet, or roughly 46 squares, since:

$$1 \text{ square} = 100 \text{ square feet}$$

The application of roofing requires trimming of shingles in valleys, roof penetrations and rake edges. Once the roof area is determined the amount of shingle material will need to be adjusted for the trimming. The increase in the amount needed to complete the roofing project will vary depending on the roof complexity. In most cases it should be between 2% and 10%.

A Roof Pitch and Slope
Determining Your Roof's Slope

The slope of your roof is determined by the vertical rise in inches for every horizontal twelve-inch (12") length (called the "run"). It is expressed with the rise mentioned first and the run mentioned second. For instance, if your roof has a four inch (4") rise for every horizontal foot, then it is said to have a "4 in 12" slope.

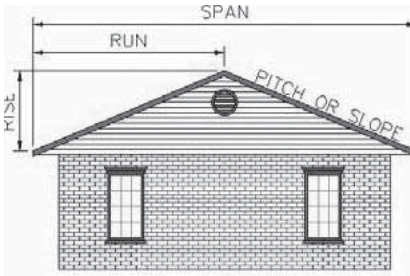

A fairly easy way to determine the slope is to use a 12" carpenter's level. Set one end on the roof surface and level the carpenter's level. Using a tape measure or a ruler, measure from the other

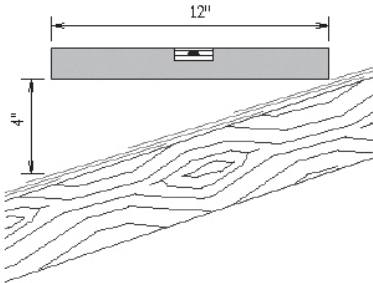

Additional Material Estimates

To complete the estimate, the required quantity of starter strips, drip edges, hip and ridge shingles and valley strips must be determined. Each of these estimates depends on the length of the eave, rakes, hips, ridges and valleys at which the material will be applied.

Most roofing jobs require anywhere from 2% to 10% excess shingles due to trim waste. The amount of trim waste depends on how many valleys, dormers, hips and roof penetrations.

Note: The drawings and some of the descriptions found in "Estimating Area (Complex Roofs)" have been used courtesy of E. J. Sandquist, www.roofhelp.com.

BERKSHIRE® COLLECTION

Application Instructions

Before installing this product, check local building codes for their roofing requirements. These laminated shingles are designed for new or reroofing work over any properly built and supported wood roof deck having adequate nail-holding capacity and a smooth surface. Check local building codes regarding deck load limits. Because Owens Corning® Berkshire® shingles are 360 avg. wt./sq., it must be determined if the roof frame can support workers and the weight of the shingles. It may not be feasible to apply the product over an existing shingle roof.

Precautionary Note:

The manufacturer will not be responsible for problems resulting from any deviation from the recommended application instructions and the following precautions:

Roof Top Loading: Lay shingle bundles flat. Do not bend over the ridge.

Roof Deck: • 6" Minimum roof deck boards • Minimum $\frac{3}{8}$ " plywood • Minimum $\frac{7}{16}$ " OSB

Regardless of deck type used, the roofing installer must:

1. Install the deck material in strict compliance with the deck manufacturer's instructions.
2. Prevent the deck from getting wet before, during and after installation.

Ventilation: Must meet local building codes.

Handling: Use extra care in handling shingles when the temperature is below 40°F.

Storage: Do not stack more than two pallets high. Store in a covered, ventilated area at a maximum temperature of 110°F.

Nails must be corrosion-resistant, 11- or 12-gauge, with heads at least $\frac{3}{8}$ " in diameter in compliance with ASTM D1667. **Staples** must be 16-gauge minimum, 15/16" minimum crown width and sufficient length to penetrate $\frac{3}{4}$ " into wood decking or through APA-rated roof sheathing. Staples are to be corrosion protected.

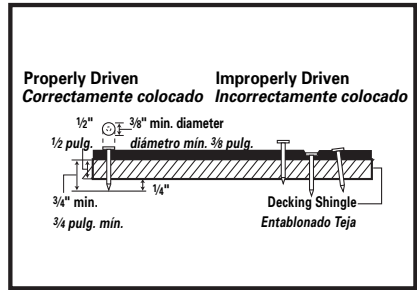

All Fasteners must penetrate at least $\frac{3}{4}$ " into the wood deck or completely through plywood sheathing.

Notice: Owens Corning recommends the use of nails as the preferred method of attaching shingles to wood decking or other nailable surfaces.

1 Specialty Eave Flashing:

WeatherLock® Underlayment or equivalent eave and flashing membrane applied to a point at least 24" beyond interior wall line. See manufacturer's installation instructions. See Fig. 1.

Fig. 1 Specialty Eave Flashing
Revestimiento especial para alero

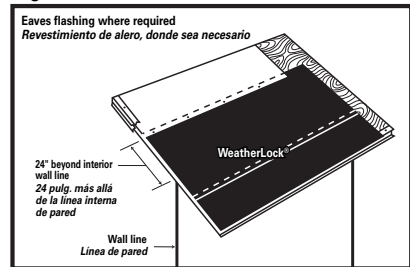

2 Underlayment:

Standard Slope (4" in 12" or more)
Application of underlayment, metal drip edges, and ice dam protection: See Fig. 2.

Low Slope (2" in 12" to less than 4" in 12")

Application of underlayment and metal drip edges: See Fig. 2A.

Fig. 2 Underlayment Standard Slope
Capa inferior con pendiente estándar

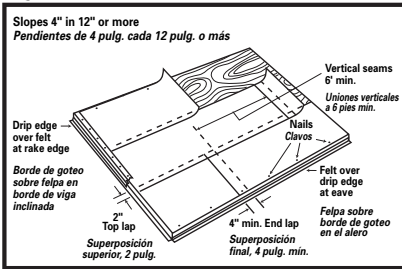
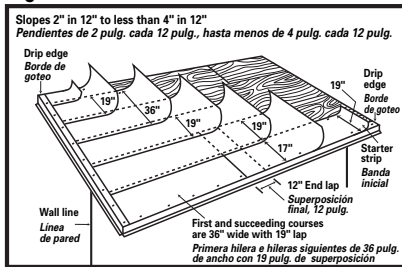

Fig. 2A Underlayment Low Slope
Capa inferior con pendiente baja



3 Chalk Lines:

To aid in shingle alignment, it is recommended that chalk lines be snapped on the exposed surface of the underlayment prior to shingle application. See Fig. 3.

Fig. 3 Chalk Lines
Líneas de tiza

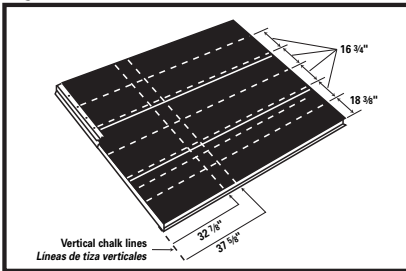

4 Starter Course:

Use *Berkshire* Shingles. Apply per Fig. 4.

Caution: Using shingle products other than *Berkshire* for the starter course may result in a color variation at the lower edge of the roof.

Fig. 4 Starter Course
Hilera inicial

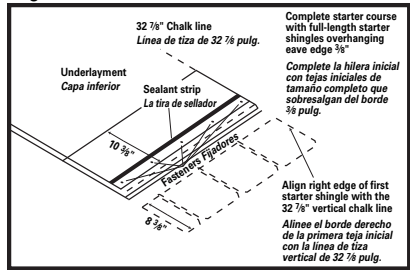

5 Shingle Fastening:

Standard Fastening Pattern.

See Fig. 5.

Place fasteners 5/8" above the tab cutout and below the lower edge of the sealant strip. Fastening into the sealant strip interferes with sealing and contributes to blow-offs.

Note: Do not drive fasteners into or above the adhesive strip.

Mansard or Steep Slope Fastening Pattern. See Fig. 5A.

REQUIRED: For slopes exceeding 60 degrees or 21 inches per foot, use six fasteners and four spots of asphalt plastic cement per shingle. Apply immediately; one 1" diameter spot of asphalt plastic cement 2" up from bottom edge of shingle tab. See Fig. 5A.

Plastic Cement where required must meet ASTM D4586 Type I or II (Asbestos Free).

Fig. 5 Standard Fastening Pattern
Esquema de fijación estándar

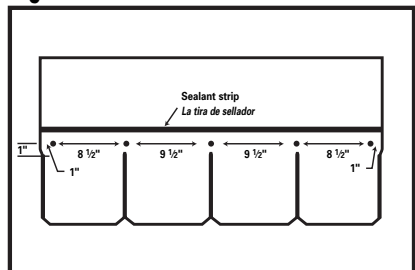

BERKSHIRE[®] SHINGLES

Fig. 5A Mansard or Steep Slope Fastening Pattern
Esquema de fijación para mansardas o pendientes agudas

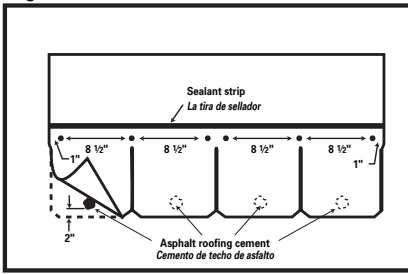

6 Course Application:

Vertical Racking Method. Apply shingles over properly prepared roof deck, starting at bottom of roof using the single-column, vertical-racking method. Owens Corning *Berkshire* shingles **must** be applied with a $4\frac{3}{4}$ " offset and $8\frac{3}{8}$ " exposure. Caution must be exercised to ensure that end joints are no closer than 2" from a fastener in the shingle below. Refer to course application steps for specific instructions.

Note: Owens Corning *Berkshire* shingles ARE NOT to be installed across and diagonally up the roof.

First Course:

Apply first course starting with a full shingle, even with the lower edge of the starter course shingle, align the right edge of the shingle with the $37\frac{7}{8}$ " vertical line. Align the top edge of the shingle with the $18\frac{3}{8}$ " horizontal chalk line. See Fig. 6.

Second Course:

Align the right edge of the first shingle of the second course with the $32\frac{7}{8}$ " vertical chalk line. Align bottom edge of the shingle with the top of the shingle cutouts in the first course, leaving $8\frac{3}{8}$ " exposure. Fasten securely and trim $4\frac{3}{4}$ " excess overhang at rake, leaving $\frac{3}{8}$ " overhang. See Fig. 6A.

Succeeding Courses:

Alternate shingle courses. Odd-numbered courses start with a full shingle aligned with the $37\frac{7}{8}$ " vertical chalk line and the top edge aligned with the horizontal chalk line, leaving $8\frac{3}{8}$ " exposure. Even-numbered courses will start with the right edge of the shingle aligned with the

$32\frac{7}{8}$ " vertical chalk line. Shingles are applied up the rake in a single-column racking fashion. See Fig. 6B.

Fig. 6 Shingle Application
Aplicación de tejas

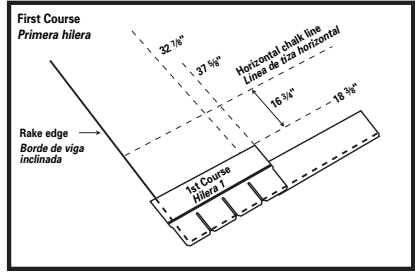

Fig. 6A Shingle Application
Aplicación de tejas

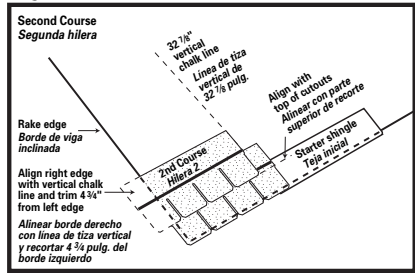
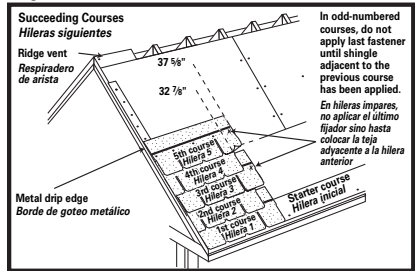

Fig. 6B Shingle Application
Aplicación de tejas



Fasten each **full** shingle in the odd- numbered courses with **four (4) fasteners**. **DO NOT** fasten the right edge of the full shingles in the odd- numbered courses at this time as the shingle being installed adjacent to the previous course will have to be positioned beneath the right edge of this full shingle. When the shingle adjacent to the previous course has been positioned, apply five (5) fasteners in that shingle (even-numbered courses) and apply one fastener to the unfastened end of the shingle above.

Fasten the shingles in the even-numbered (where the first shingle in the course is aligned with the $3\frac{7}{8}$ " chalk line) courses using five (5) fasteners. See Fig. 6B.

Work up the roof starting at the eave edge one column at a time following the above procedure. Butt full shingles against the right edge of the shingles that have been applied in each course, again working one column at a time until the courses have been completed.

7 Open Valley Construction:

Woven and closed-cut valleys are not recommended for Owens Corning Berkshire shingles.

Lay a 36"-wide valley liner of Owens Corning® WeatherLock® underlayment or equivalent. A 36"-wide minimum #50 smooth surface roll roofing can also be used as a valley liner. Fasten on outer edges only a minimum of 6" away from center-line on each side of valley. See Fig. 7.

Recommended valley flashing is 24"-wide 26-gauge galvanized metal or an equivalent corrosion-resistant, nonstaining material. Secure the valley metal to the roof deck with fasteners spaced 8"-12" apart. Overlaps should be 12" and cemented. See Fig. 7.

Snap a chalk line on each side of the valley centerline over the full length of the valley flashing. Space the chalk lines 6" apart at the ridge (3" to either side of the valley centerline). The lower ends of the chalk lines should diverge from each other $\frac{1}{8}$ " per foot (i.e., for an 8' valley the chalk lines will be 7" apart at the eaves). See Fig. 7A.

As the shingles are applied toward the valley, the last shingle in each course will be trimmed to fit on the chalk line.

Note: Do not use a shingle less than 12" in length to finish a course running into a valley.

If necessary, trim a tab off the adjacent shingle in the course to allow a longer portion to be used.

Clip 1" from the upper portion of the shingle on a 45° angle to divert water into the valley. See Fig. 7A.

Cement the shingle to the valley lining with a 3"-wide band of asphalt plastic cement conforming to ASTM D 4586, Type I or II. See Fig. 7A.

Fig. 7 Open Valley Construction
Construcción con canal descubierto

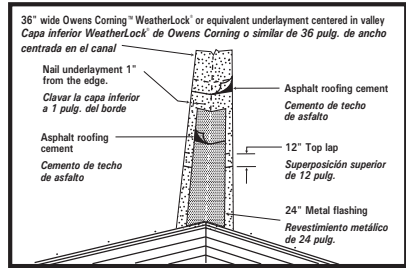
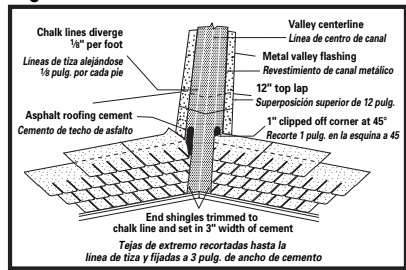

Fig. 7A Open Valley Construction
Construcción con canal descubierto



8 Step Flashing:

Use 4"x4"x12" corrosion-resistant metal where roof planes butt against vertical sidewalls or chimneys. See Fig. 8.

Fig. 8 Step Flashing
Revestimiento escalonado

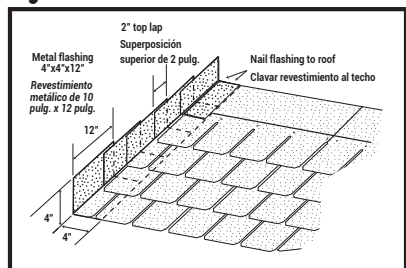

9 Hip & Ridge Application:

Use Berkshire Hip and Ridge Shingles.

Follow application instructions as printed on the Berkshire Hip & Ridge carton.

WOODMOOR® & WOODCREST® SHINGLES

Application Instructions:

Before installing this product, check local building codes for their roofing requirements.

These laminated shingles are designed for new or reroofing work over any properly built and supported wood roof deck having adequate nail holding capacity and a smooth surface. Check local building codes regarding deck load limits. Because Owens Corning® Woodcrest®/Woodmoor® shingles are 360/465 avg. wt./sq., it must be determined if the roof frame can support workers and the weight of the shingles. It may not be feasible to apply the product over an existing shingle roof.

Precautionary Note:

The manufacturer will not be responsible for problems resulting from any deviation from the recommended application instructions and the following precautions:

Roof Top Loading: Lay shingle bundles flat. Do not bend over the ridge.

Roof Deck: • 6" Minimum roof deck boards
• Minimum 3/8" plywood • Minimum 7/16" OSB

Regardless of deck type used, the roofing installer must:

1. Install the deck material in strict compliance with the deck manufacturer's instructions.
2. Prevent the deck from getting wet before, during and after installation.

Ventilation: Must meet local building codes.

Handling: Use extra care in handling shingles when the temperature is below 40°F.

Storage: Store in a covered ventilated area at a maximum temperature of 110°F. Stack in a flat fashion (maximum of 10 bundles high). Protect shingles from weather when stored at the job site. Do not store near steam pipes, radiators, etc.

Nails must be corrosion-resistant, 11- or 12-gauge, with heads at least 3/8" in diameter. Staples must be 16-gauge minimum, 15/16" minimum crown width and sufficient length to penetrate 3/4" into wood decking or through APA-rated roof

sheathing. Staples are to be corrosion protected.

All Fasteners must penetrate at least 3/4" into the wood deck or completely through plywood sheathing.

Notice: Owens Corning recommends the use of nails as the preferred method of attaching shingles to wood decking or other nailable surface.

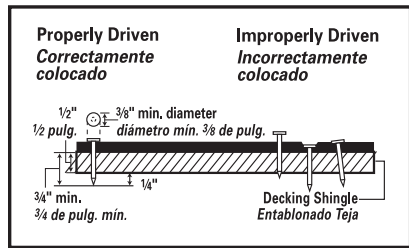

- 1 **Specialty Eave Flashing:** WeatherLock® underlayment or equivalent eave and flashing membrane applied to a point at least 24" beyond interior wall line. See manufacturer's installation instructions. See Fig. 1.

Fig. 1 Specialty Eave Flashing
Revestimiento especial para alero

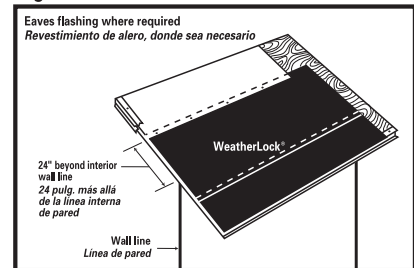

- 2 **Underlayment:**
Standard Slope (4" in 12" or more): Application of underlayment, metal drip edges, and ice dam protection: See Fig. 2.

Low Slope (2" in 12" to less than 4" in 12"): Application of underlayment and metal drip edges: See Fig. 2A.

Fig. 2 Underlayment Standard Slope
Capa inferior con pendiente estándar

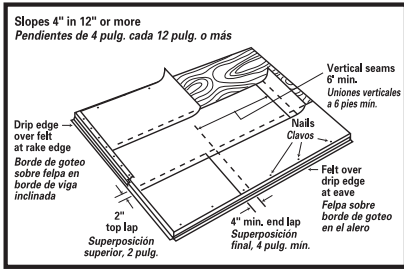
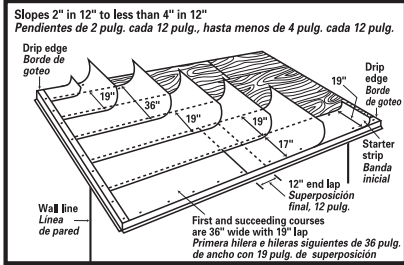

Fig. 2A Underlayment Low Slope
Capa inferior con pendiente baja



3 Starter Course:

Left Rake Application: Cut 35" off from the first bottom starter piece. Fasten the remaining 5" x 13³/₈" to the deck as shown in Fig. 3, followed by a full 13³/₈" x 40" starter piece to the deck with 5 fasteners as shown.

Right Rake Application: Cut 5" off from the first bottom starter piece. Fasten the remaining 35" x 13³/₈" to the deck as shown in Fig. 3, followed by a full 13³/₈" x 40" starter piece to the deck with 5 fasteners as shown.

Caution: Using shingle products other than WoodStart® Starter Strip for the starter course may result in a color variation at the lower edge of the roof.

Fig. 3 Starter Course
Hilera inicial

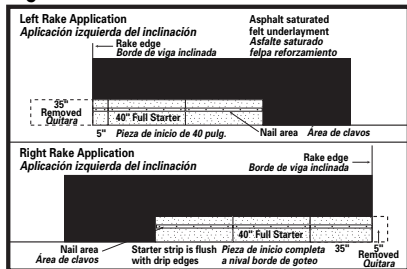

4 Shingle Fastening:
Standard Fastening Pattern:

Place fasteners in nail area. See Fig. 4.

Fig. 4 Standard Fastening Pattern
Esquema de fijación estándar

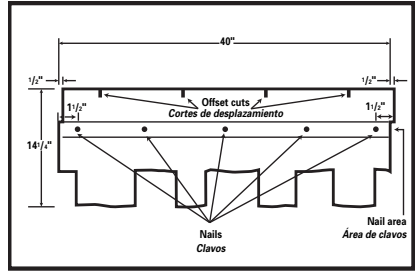

5 Mansard or Steep Slope Fastening Pattern: See Fig. 5.

REQUIRED: For slopes exceeding 60 degrees or 21 inches per foot, 9 nails are required with 5 in the nail area and 4 placed above tab cutouts.

1. Position the first course shingle applying 5 nails in the nail area.
2. Temporarily position the second course shingle above to determine the location for the additional 4 fasteners.
3. Once you have added the additional fasteners in the tab area, apply 4 spots of asphalt cement under each tab and press in place.
4. Apply all succeeding shingle courses in the same manner.

Note: Too much roofing cement can cause shingles to blister.

Plastic Cement where required must meet ASTM D4586, Type I or II (Asbestos Free).

Fig. 5 Mansard or Steep Slope Fastening Pattern
Esquema de fijación para mansardas o pendientes agudas

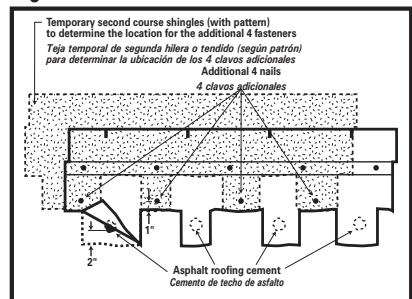

6 Measurement Area:

When aligning for offset pattern, measure from area A or area B. See Fig. 6.

Fig. 6 Measurement Area
Área de medida

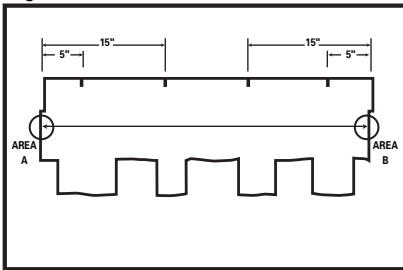

7 5" & 5" Course Application:

Owens Corning® Woodcrest®/ Woodmoor® shingles can be applied with a 5" & 5" OR 5" & 15" offset, (See Fig. 4) with 4" exposure. Shingles can be installed from either left or right rake edge.

First Course: Start with a full shingle even with the lower edge of the starter course shingle. See Fig. 7.

Fig. 7 Shingle Application 5" & 5" offset pattern
Aplicación de tejas en patrón de desplazamiento de 5 pulg. y 5 pulg.

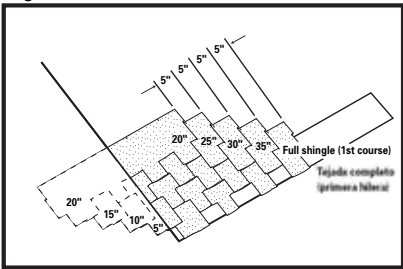

8 5" & 15" Course Application:

Owens Corning® Woodcrest®/ Woodmoor® shingles can be applied with a 5" & 5" OR 5" & 15" offset, (See Fig. 4) with 4" exposure. Shingles can be installed from either left or right rake edge.

First Course: Start with a full shingle even with the lower edge of the starter course shingle. See Fig. 8.

Second Course: Cut 5" from a full shingle. Install the remaining 35" piece using the alignment notch on the shingle. See Fig. 8A.

Third Course: Cut 20" from a full shingle. Install the remaining 20" piece using the alignment notch on the shingle. See Fig. 8B.

Fourth Course: Cut 25" from the edge of the fourth course full shingle. Install the remaining 15" piece using the alignment notch on the shingle. See Fig. 8C.

Succeeding Courses: For succeeding courses, repeat first through fourth course. See Fig. 8D.

Fig. 8 Shingle Application 5" & 15" offset pattern
Aplicación de tejas en patrón de desplazamiento de 5 pulg. y 15 pulg.

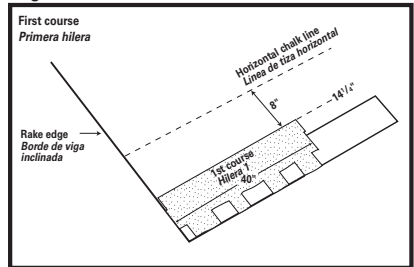

Fig. 8A Shingle Application 5" & 15" offset pattern
Aplicación de tejas en patrón de desplazamiento de 5 pulg. y 15 pulg.

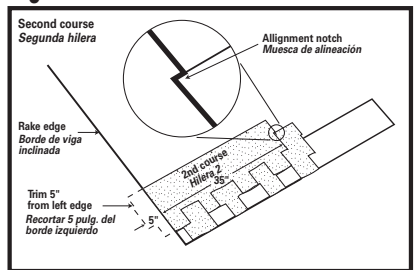

Fig. 8B Shingle Application 5" & 15" offset pattern
Aplicación de tejas en patrón de desplazamiento de 5 pulg. y 15 pulg.

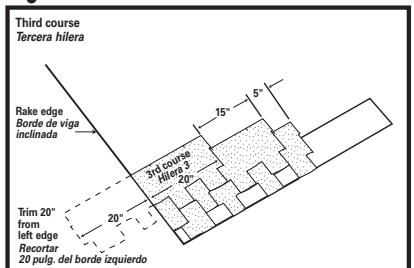

Fig. 8C Shingle Application 5" & 15" offset pattern
 Aplicación de tejas en patrón de desplazamiento de 5 pulg. y 15 pulg.

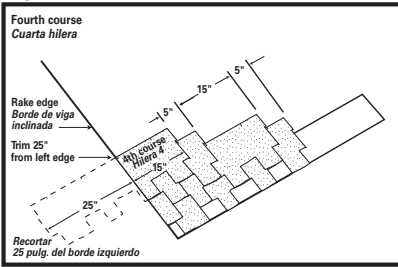
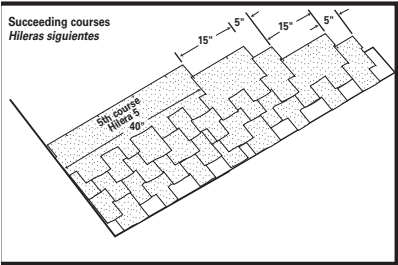

Fig. 8D Shingle Application
 Aplicación de tejas



9 Valley Construction: Open Valley

Lay a 36" wide valley liner of Owens Corning® WeatherLock® underlayment or equivalent. A 36" wide minimum 50-lb. smooth surface roll roofing can also be used as a valley liner. Fasten on outer edges only a minimum of 6" away from centerline on each side of valley. See Fig. 9.

Recommended valley flashing is 24" wide 26-gauge galvanized metal or an equivalent corrosion-resistant, nonstaining material. Secure the valley metal to the roof deck along each edge with fasteners spaced 8"-12" apart. Overlaps should be 12" and cemented. See Fig. 9.

Fig. 9 Open Valley Construction
 Construcción con canal descubierto

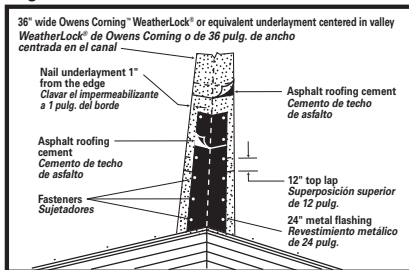

Snap a chalk line on each side of the valley centerline over the full length of the valley flashing. Space the chalk lines 6" apart at the ridge (3" to either side of the valley centerline). The lower ends of the chalk lines should diverge from each other 1/8" per foot (i.e., for an 8' valley the chalk lines will be 7" apart at the eaves). See Fig. 9A.

Fig. 9A Open Valley Construction
 Construcción con canal descubierto

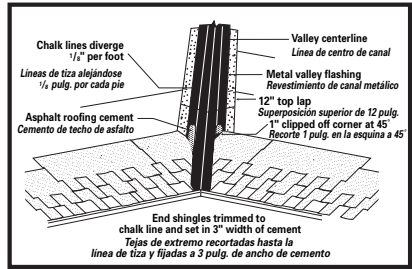

As the shingles are applied toward the valley, the last shingle in each course will be trimmed to fit on the chalk line. **Note: Do not use a shingle less than 12" in length to finish a course running into a valley.** If necessary, trim a tab off the adjacent shingle in the course to allow a longer portion to be used.

Clip 1" from the upper portion of the shingle on a 45° angle to divert water into the valley. See Fig. 9A.

Cement the shingle to the valley lining with a 3" wide band of asphalt plastic cement conforming to ASTM D4586, Type I or II. See Fig. 9A.

Closed-Cut Valley See Fig. 9B.

Fig. 9B Closed-Cut Valley Construction
 Construcción con canal de corte cerrado

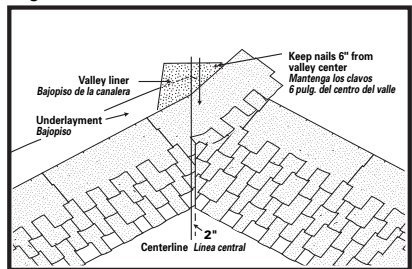

A closed-cut valley can be used as an alternative and is applied as follows:

Lay a 36" wide valley liner of Owens Corning® WeatherLock® underlayment or equivalent. A 36" wide minimum 50-lb. smooth surface roll roofing can also be used as a valley liner.

Lay all shingles on one side of valley and across centerline of valley a minimum of 12". Fasten a minimum of 6" away from centerline on each side of valley.

Strike a chalk line 2" from the centerline of the unshingled side. Apply shingles on the unshingled side up to the chalk line and trim, taking care not to cut the underlying shingles. Clip upper corners of these shingles, cement and fasten.

Both woven and metal valleys are acceptable alternatives.

10 Step Flashing:

Use 4"x4"x6" corrosion-resistant metal where roof planes butt against vertical sidewalls or chimneys. See *Fig. 10*.

Fig. 10 Step Flashing
Revestimiento escalonado

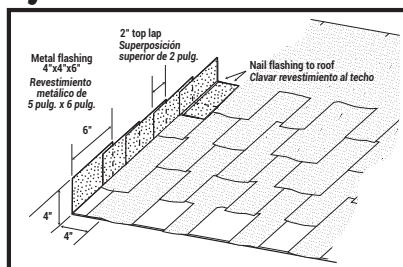

11 Hip & Ridge Application:

Use Owens Corning® DecoRidge® Hip & Ridge shingles.

Follow the application instructions as printed on the DecoRidge® Hip & Ridge carton.

TRUDEFINITION® DURATION®; DURATION® PREMIUM COOL; TRUDEFINITION® DURATION® COOL; TRUDEFINITION® DURATION® DESIGNER

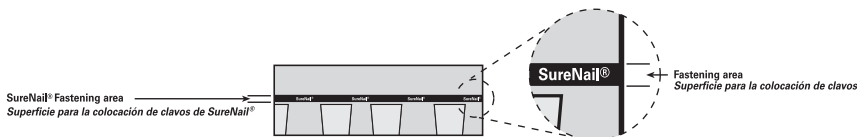

Application Instructions

Before installing this product, check local building codes for their roofing requirements.

These shingles are designed for new or reroofing work over any properly built and supported wood roof deck having adequate nail holding capacity and a smooth surface. Check local building codes.

Precautionary Note:

The manufacturer will not be responsible for problems resulting from any deviation from the recommended application instructions and the following precautions:

Roof Top Loading: Lay shingle bundles flat. Do not bend over the ridge.

Roof Deck: • 6" Minimum roof deck boards
• Minimum 3/8" plywood • Minimum 7/16" OSB

Regardless of deck type used, the roofing installer must:

1. Install the deck material in strict compliance with the deck manufacturer's instructions.
2. Prevent the deck from getting wet before, during and after installation.

Ventilation: Must meet or exceed FHA Minimum Property Standards.

Handling: Use extra care in handling shingles when the temperature is below 40°F.

Shingle Cutting: For best results ensure that all cutting devices are sharp and that when cutting shingles it is best to cut with a quick motion as you pull the roofing knife through the shingle.

Storage: Store in a covered ventilated area at a maximum temperature of 110°F. Bundles should be stacked flat. Protect shingles from weather when stored at the job site. Do not store near steam pipes, radiators, etc.

Fastener requirement: Use galvanized steel, stainless steel, or aluminum nails minimum 12-gauge shank with 3/8" diameter head. Owens Corning Roofing recommends that fasteners comply with ASTM F 1667. Check local building codes.

All Fasteners must penetrate at least 3/4" into the wood deck or completely through sheathing.

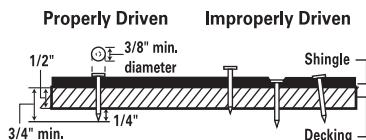

Notice: Owens Corning Roofing recommends the use of nails as the preferred method of attaching shingles to wood decking or other nailable surface.

CAUTION

ROOF SURFACE MAY BE SLIPPERY: Especially when wet or icy. Use a fall protection system when installing. Wear rubber soled shoes. Walk with care.

FALLING HAZARD: Secure area below work and materials on roof. Unsecured materials may slide on roof. Place on level plane or secure to prevent sliding. Wear a hard hat.

WARNING: This product contains a chemical known to the State of California to cause cancer.

1 Specialty Eave Flashing:

Where required by code.

WeatherLock® underlayment or equivalent eave and flashing membrane applied to a point at least 24" beyond interior wall line. See manufacturer's installation instructions. See Fig. 1.

Fig. 1 Specialty Eave Flashing
Tapajuntas especial para aleros

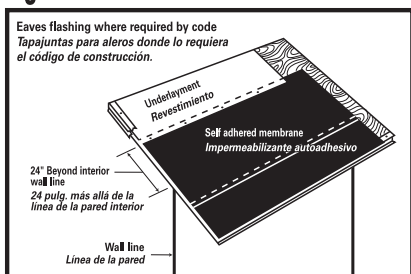

2 Underlayment:

Standard Slope (4" in 12" or more)

Application of underlayment, metal drip edges, and ice dam protection: See Fig. 2.

(A) Apply one layer of underlayment over metal drip edge at eaves. Use only enough fasteners to hold in place.

(B) Overlap successive courses 2". Overlap course ends 4". Side laps are to be staggered 6' apart.

(C) Apply metal drip edge over underlayment at rake.

Fig. 2 Underlayment Standard Slope
Pendiente estándar del revestimiento

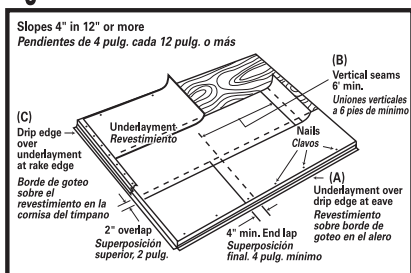

3 Underlayment:

Low Slope (2" in 12" to less than 4" in 12")

Application of roofing felt overlapped by 19 inches on each course. See Fig. 3.

(A) Apply 19" starter strip of underlayment over metal drip edge at eaves. Use only enough fasteners to hold it in place.

(B) Use 36" strip of underlayment for remaining courses, overlapping each course 19". Side laps are to be staggered 6' apart.

(C) Apply metal drip edge over underlayment at rake.

Or WeatherLock® self-adhered underlayment or equivalent with a standard overlap of 3 inches and metal drip edge. See Fig. 3A.

Fig. 3 Underlayment Low Slope
Pendiente baja del revestimiento

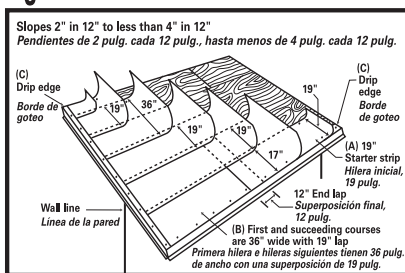
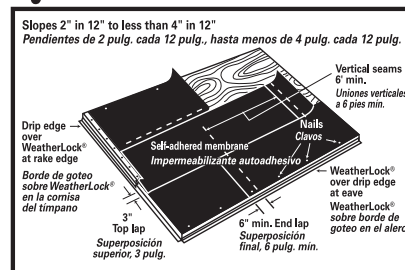

Fig. 3A Underlayment Low Slope
Pendiente baja del revestimiento



4 Shingle Fastening Pattern:

Standard Fastening Pattern.

Fasteners must be placed in the SureNail® fastening area. See Fig. 4.

Six Nail Fastening Pattern.

For 6 nail fastening pattern. See Fig. 4A.

Mansard or Steep Slope Fastening Pattern.

Place fasteners 6 1/8" from bottom edge to secure both layers of the shingle. Fasteners need to be located 6 1/8" above the butt edge of the shingle, regardless of whether they are in the granules or the SureNail® fastening area. See Fig. 4B.

Shingle Side View



REQUIRED: For slopes exceeding 60 degrees or 21" per foot, use six fasteners and four spots of asphalt cement per shingle. Apply immediately; one 1" diameter spot of asphalt cement **under** each shingle tab. Center asphalt roof cement 2" up from bottom edge of shingle tab.

Roof Cement where required must meet ASTM D-4586 Type I or II (Asbestos Free).

Fig. 4 Standard Fastening Pattern
Esquema de instalación estándar

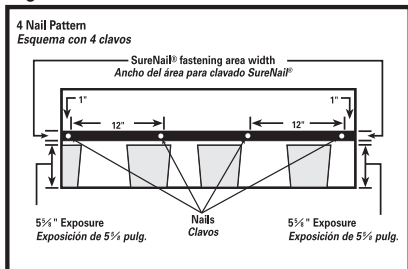

Fig. 4A Six Nail Fastening Pattern
Esquema de instalación con seis clavos

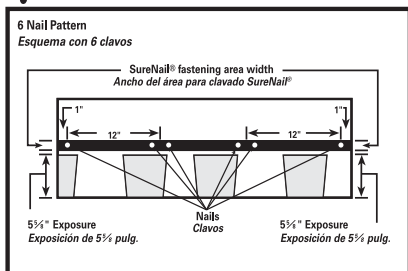
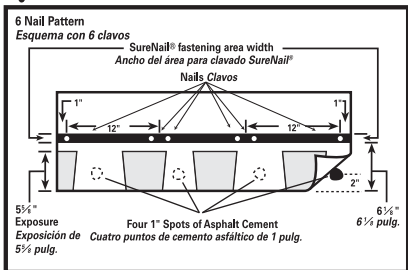

Fig. 4B Mansard or Steep Slope Fastening Pattern
Esquema de instalación en pendientes pronunciadas o mansardas



5 Shingle Application:

These shingles are applied with a 6 1/2" offset, with 5 5/8" exposure, over prepared roof deck, starting at the bottom of the roof and working across and up. This will blend

shingles from one bundle into the next and minimize any normal shade variation. Application with offsets of 4" or 5" are also acceptable.

Caution must be exercised to assure that end joints are no closer than 2" from fastener in the shingle below and that side laps are no less than 4" in succeeding courses. Refer to course application steps for specific instructions.

Starter Course:

Use starter roll or trim 5 5/8" from the starter course shingle. Trim 6 1/2" off the rake of the starter course shingle and flush with the drip edge along the rake and eaves edge, and continue across the roof. Use 5 fasteners for each shingle, placed 2" to 3" up from eaves edge. **See Fig. 5.** (If no drip edge is used, shingles must extend a minimum of 1/2" and no more than 1" from rake and eaves edge.)

First Course:

Apply first course starting with the full shingle even with the starter course. **See Fig. 5A.** Fasten securely according to fastening instructions. **See Fig. 4.**

Fig. 5 Shingle Application
Instalación de tejas

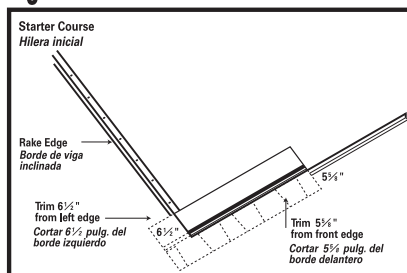
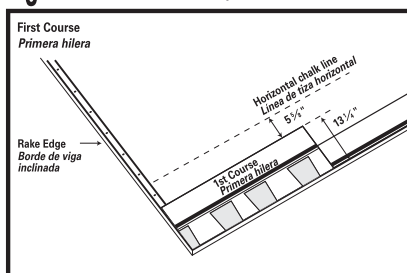

Fig. 5A Shingle Application
Instalación de tejas



Second Course:

Remove 6½" from the left end of this shingle and apply the remaining piece over and above the first course shingle and flush with edge of the first course with 5⅝" exposure. See Fig. 5B.

Fasten securely according to fastening instructions. See Fig. 4.

Fig. 5B Shingle Application
Instalación de tejas

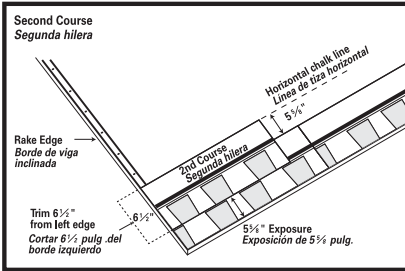

Fig. 5C Shingle Application
Instalación de tejas

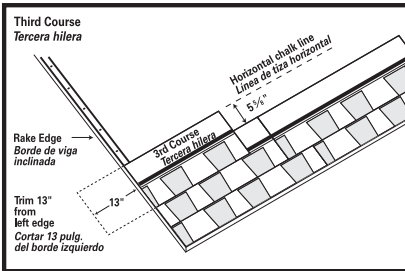
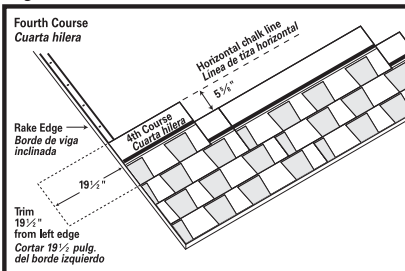

Fig. 5D Shingle Application
Instalación de tejas



Third Course:

Remove 13" from the left end of this shingle and apply the remaining piece over and above the second course shingle and flush with edge of the second course with 5⅝" exposure. See Fig. 5C.

Fasten securely according to fastening instructions. See Fig. 4.

Fourth Course:

Remove 19½" from the left end of this shingle and apply the remaining piece over and above the third course shingle and flush with edge of the third course with 5⅝" exposure. See Fig. 5D.

Fasten securely according to fastening instructions. See Fig. 4.

Fifth Course:

Remove 26" from the left end of this shingle and apply the remaining piece over and above the fourth course shingle and flush with edge of the fourth course with 5⅝" exposure. See Fig. 5E.

Fasten securely according to fastening instructions. See Fig. 4.

Fig. 5E Shingle Application
Instalación de tejas

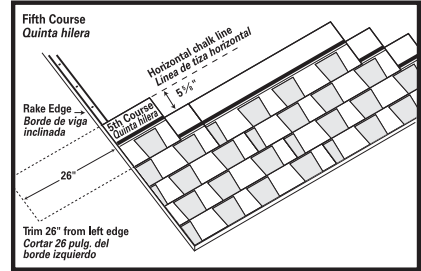

Sixth Course:

Remove 32½" from the left end of this shingle and apply the remaining piece over and above the fifth course shingle and flush with edge of the fifth course with 5⅝" exposure. See Fig. 5F.

Fasten securely according to fastening instructions. See Fig. 4.

Fig. 5F Shingle Application
Instalación de tejas

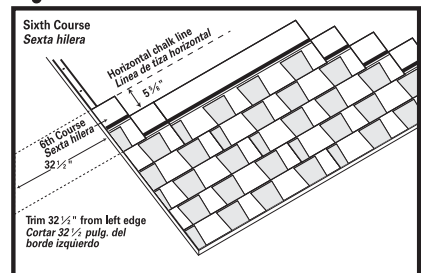

Succeeding Courses:

For succeeding courses, repeat first through sixth course. See Fig. 5G.

Fig. 5G Shingle Application
Instalación de tejas

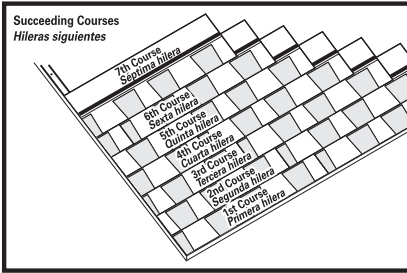

6 Valley Construction:

Closed-Cut Valley See Fig. 6.

A closed-cut valley can be used as an alternative to woven or open valley and is applied as follows:

Lay a 36" wide valley liner of self-adhered membrane underlayment or equivalent. A 36" wide minimum 50 lb. roll roofing can also be used as a valley liner.

Lay all shingles on one side of valley and across center line of valley a minimum of 12". Fasten a minimum of 6" away from center line on each side of valley.

Strike a chalk line 2" from the center line of the unshingled side. Apply shingles on the unshingled side up to the chalk line and trim, taking care not to cut the underlying shingles. Clip upper corners of these shingles, cement and fasten.

Both woven and metal valleys are acceptable alternatives.

Fig. 6 Closed-Cut Valley Construction
Construcción del valle con corte cerrado

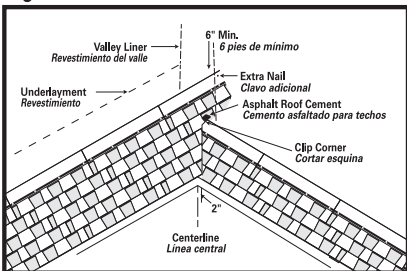

7 Step Flashing:

Use 10" long and 2" wider than expected exposure corrosion-resistant metal where roof planes butt against vertical sidewalls or chimneys. See Fig. 7. Check local building codes.

Fig. 7 Step Flashing
Tapajuntas escalonado

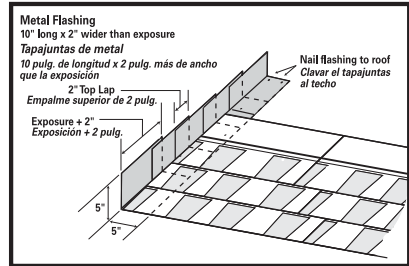

8 Hip & Ridge Application:

Use corresponding Owens Corning® Hip & Ridge shingles to best complement shingle color. Follow specific application instructions as printed on the Hip & Ridge shingle package. See Fig. 8.

Fig. 8 Hip & Ridge Application
Instalación de caballetes y cumbresras

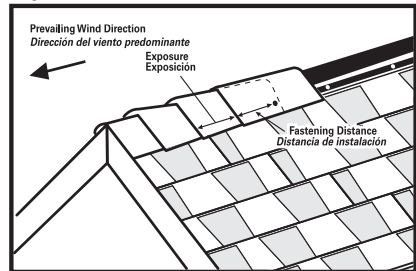

TRUDEFINITION® DURATION STORM® SHINGLES

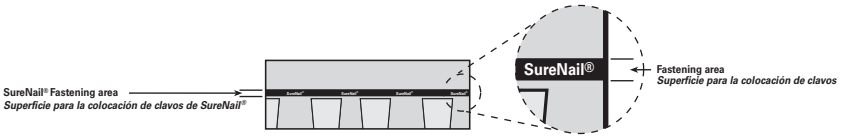

Application Instructions

Before installing this product, check local building codes for their roofing requirements.

These shingles are designed for new or reroofing work over any properly built and supported wood roof deck having adequate nail holding capacity and a smooth surface. Check local building codes.

Precautionary Note:

The manufacturer will not be responsible for problems resulting from any deviation from the recommended application instructions and the following precautions:

- The existing roof must be removed before installing Duration STORM® shingles.
- Use of shingle over ridge vent will affect the impact resistance classification of the Owens Corning® Impact-Resistant Hip & Ridge Shingles; use off-ridge ventilation products as an alternative.
- Spacing between the decking at the ridge should not be more than ¼" because it could affect the impact resistance classification.
- Owens Corning® Impact-Resistant Hip & Ridge Shingles must be used.

Roof Top Loading: Lay shingle bundles flat. Do not bend over the ridge.

Roof Deck: • Recommended roof decks are 6" minimum width, 25/32" minimum thickness wood sheathing. • Minimum 3/8" plywood • Minimum 7/16" OSB

Regardless of deck type used, the roofing installer must:

1. Install the deck material in strict compliance with the deck manufacturer's instructions.
2. Prevent the deck from getting wet before, during and after installation.

Ventilation: Must meet local building codes.

Handling: Use extra care in handling shingles when the temperature is below 40°F.

Shingle Cutting: For best results ensure that all cutting devices are sharp and that when cutting shingles it is best to cut with a quick motion as you pull the roofing knife through the shingle.

Storage: Store in a covered ventilated area at a maximum temperature of 110°F. Bundles should be stacked flat. Protect shingles from weather when stored at the job site. Do not store near steam pipes, radiators, etc.

Fastener requirement: Use galvanized steel, stainless steel, or aluminum nails minimum 12 gauge shank with 3/8" diameter head. Owens Corning Roofing recommends that fasteners comply with ASTM F1667. Check local building codes.

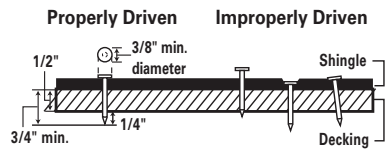

All Fasteners must penetrate at least ¾" into the wood deck or completely through sheathing.

Notice: Owens Corning Roofing recommends the use of nails as the preferred method of attaching shingles to wood decking or other nailable surface.

1 Specialty Eave Flashing: Where required by code.

WeatherLock® underlayment or equivalent eave and flashing membrane applied to a point at least 24" beyond interior wall line. See manufacturer's installation instructions. See Fig. 1.

Fig. 1 Specialty Eave Flashing
Tapajuntas especial para aleros

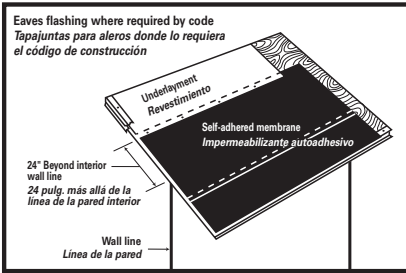

2 Underlayment:

Standard Slope (4" in 12" or more)

Application of underlayment, metal drip edges, and ice dam protection: See Fig. 2.

- (A) Apply one layer of underlayment over metal drip edge at eaves. Use only enough fasteners to hold in place.
- (B) Overlap successive courses 2". Overlap course ends 4". Side laps are to be staggered 6' apart.
- (C) Apply metal drip edge over underlayment at rake.

Fig. 2 Underlayment Standard Slope
Pendiente estándar del revestimiento

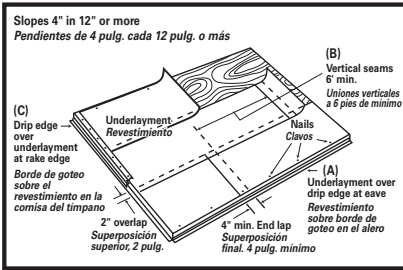

3 Underlayment:

Low Slope (2" in 12" to less than 4" in 12")

Application of roofing felt overlapped by 19" on each course. See Fig. 3.

- (A) Apply 19" starter strip of underlayment over metal drip edge at eaves. Use only enough fasteners to hold it in place.
- (B) Use 36" strip of underlayment for remaining courses, overlapping each course 19". Side laps are to be staggered 6' apart.
- (C) Apply metal drip edge over underlayment at rake.

Or WeatherLock® self-adhered underlayment or equivalent with a standard over lap of 3" and metal drip edge. See Fig. 3A.

Fig. 3 Underlayment Low Slope
Pendiente baja del revestimiento

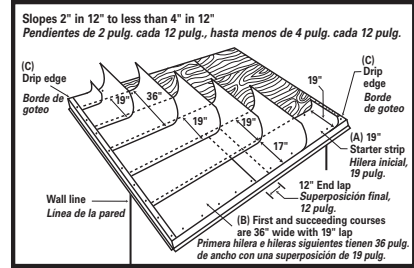
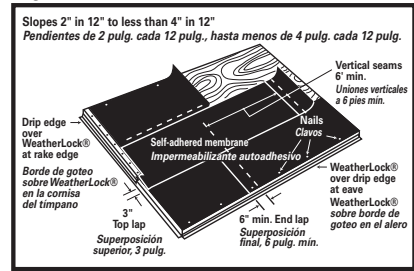

Fig. 3A Underlayment Low Slope
Pendiente baja del revestimiento



4 Shingle Fastening Pattern:

Standard Fastening Pattern.

Fasteners must be placed in the SureNail® fastening area. See Fig. 4.

Six Nail Fastening Pattern.

For 6 nail fastening pattern. See Fig. 4A.

Mansard or Steep Slope Fastening Pattern.

Place fasteners 6 1/8" from bottom edge to secure both layers of the shingle. Fasteners need to be located 6 1/8" above the butt edge of the shingle, regardless of whether they are in the granules or the SureNail® fastening area. See Fig. 4B.

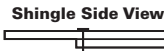

REQUIRED: For slopes exceeding 60 degrees or 21 inches per foot, use six fasteners and four spots of asphalt cement per shingle. Apply immediately; one 1" diameter spot of asphalt cement **under** each shingle tab. Center asphalt roof cement 2" up from bottom edge of shingle tab.

TRUDEFINITION™
DURATION STORM® SHINGLES

Roof Cement where required must meet ASTM D-4586 Type I or II (Asbestos Free).

Fig. 4 Standard Fastening Pattern
Esquema de instalación estándar

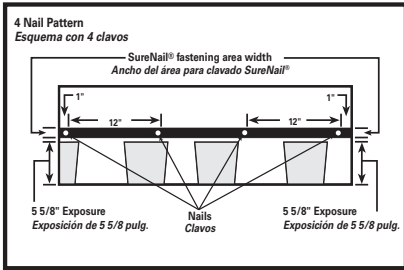

Fig. 4A Six Nail Fastening Pattern
Esquema de instalación con seis clavos

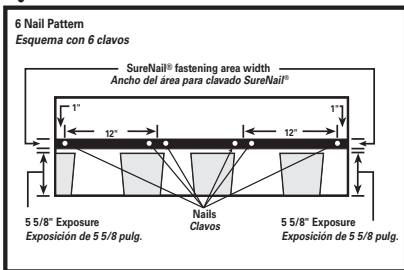
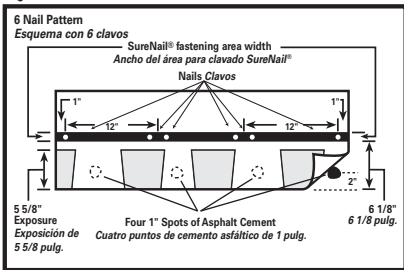

Fig. 4B Mansard or Steep Slope Fastening Pattern
Esquema de instalación en pendientes pronunciadas o mansardas



5 Shingle Application:

These shingles are applied with a 6½" offset, with 5⅝" exposure, over prepared roof deck, starting at the bottom of the roof and working across and up. This will blend shingles from one bundle into the next and minimize any normal shade variation. Application with offsets of 4" or 5" are also acceptable.

Caution must be exercised to assure that end joints are no closer than 2" from fastener in the shingle below and that side laps are no

less than 4" in succeeding courses. Refer to course application steps for specific instructions.

Starter Course:

Use starter roll or trim 5⅝" from the starter course shingle. Trim 6½" off the rake of the starter course shingle and flush with the drip edge along the rake and eaves edge, and continue across the roof. Use 5 fasteners for each shingle, placed 2" to 3" up from eaves edge. See Fig. 5. (If no drip edge is used, shingles must extend a minimum of ½" and no more than 1" from rake and eaves edge.)

First Course:

Apply first course starting with the full shingle even with the starter course. See Fig. 5A.

Fasten securely according to fastening instructions. See Fig. 4.

Fig. 5 Shingle Application
Instalación de tejas

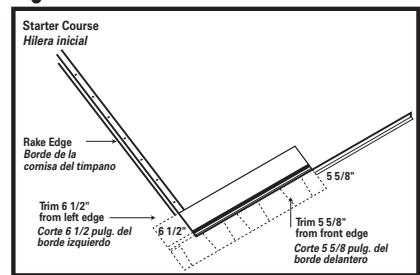
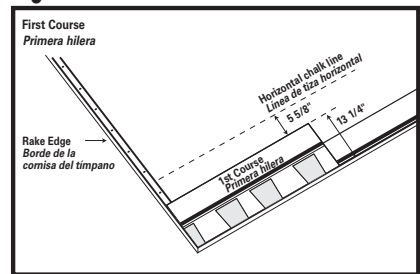

Fig. 5A Shingle Application
Instalación de tejas



Second Course:

Remove 6½" from the left end of this shingle and apply the remaining piece over and above the first course shingle and flush with edge of the first course with 5⅝" exposure. See Fig. 5B.

Fasten securely according to fastening instructions. See Fig. 4.

Third Course:

Remove 13" from the left end of this shingle and apply the remaining piece over and above the second course shingle flush with edge of the second course with $5\frac{5}{8}$ " exposure. See Fig. 5C.

Fasten securely according to fastening instructions. See Fig. 4.

Fig. 5B Shingle Application
Instalación de tejas

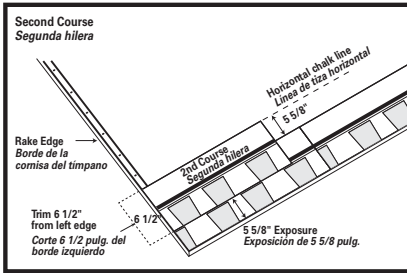
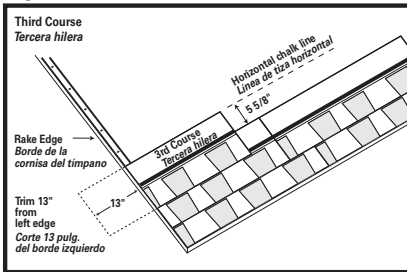

Fig. 5C Shingle Application
Instalación de tejas



Fourth Course:

Remove $19\frac{1}{2}$ " from the left end of this shingle and apply the remaining piece over and above the third course shingle and flush with edge of the third course with $5\frac{5}{8}$ " exposure. See Fig. 5D.

Fasten securely according to fastening instructions. See Fig. 4.

Fig. 5D Shingle Application
Instalación de tejas

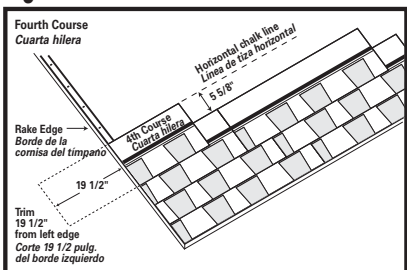

Fifth Course:

Remove 26" from the left end of this shingle and apply the remaining piece over and above the fourth course shingle and flush with edge of the fourth course with $5\frac{5}{8}$ " exposure. See Fig. 5E.

Fasten securely according to fastening instructions. See Fig. 4.

Fig. 5E Shingle Application
Instalación de tejas

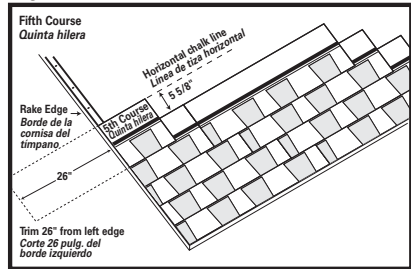

Sixth Course:

Remove $32\frac{1}{2}$ " from the left end of this shingle and apply the remaining piece over and above the fifth course shingle and flush with edge of the fifth course with $5\frac{5}{8}$ " exposure. See Fig. 5F.

Fasten securely according to fastening instructions. See Fig. 4.

Fig. 5F Shingle Application
Instalación de tejas

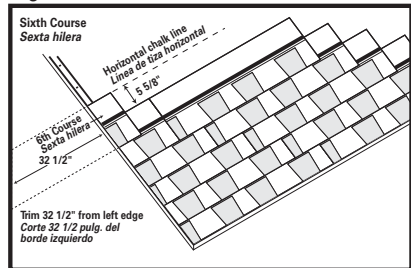

Succeeding Courses:

For succeeding courses, repeat first through sixth course. See Fig. 5G.

Fig. 5G Shingle Application
Instalación de tejas

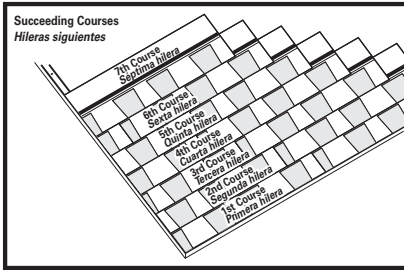

6 Valley Construction:

Closed-Cut Valley See Fig. 6.

A closed-cut valley can be used as an alternative to woven or open valley and is applied as follows:

Lay a 36"-wide valley liner of self-adhered membrane underlayment or equivalent. A 36"-wide minimum 50-lb. roll roofing can also be used as a valley liner.

Lay all shingles on one side of valley and across centerline of valley a minimum of 12". Fasten a minimum of 6" away from centerline on each side of valley.

Strike a chalk line 2" from the centerline of the unshingled side. Apply shingles on the unshingled side up to the chalk line and trim, taking care not to cut the underlying shingles. Clip upper corners of these shingles, cement and fasten.

Both woven and metal valleys are acceptable alternatives.

Fig. 6 Closed-Cut Valley Construction
Construcción del valle con corte cerrado

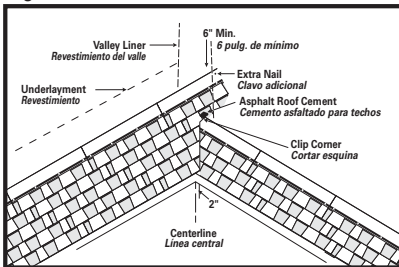

7 Step Flashing:

Use 10" long and 2" wider than expected exposure corrosion-resistant metal where roof planes butt against vertical sidewalls or chimneys. See Fig. 7. Check local building codes.

Fig. 7 Step Flashing
Tapajuntas escalonado

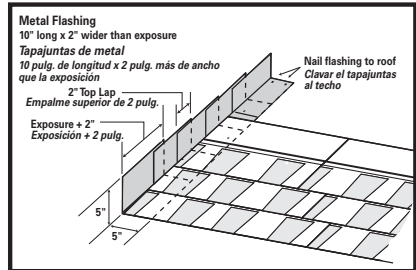

8 Hip & Ridge Application:

Use Owens Corning® Impact-Resistant Hip & Ridge Shingles to best complement shingle color. Follow specific application instructions as printed on the Hip & Ridge shingle package. See Fig. 8.

Fig. 8 Hip & Ridge Application
Instalación de tejas para caballetes y cumbreras

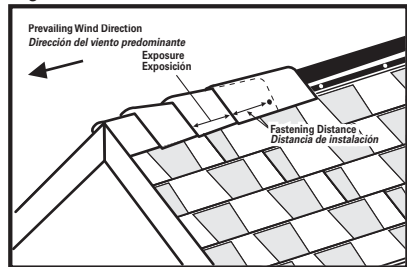

TRUDEFINITION®
DURATION STORM® SHINGLES

TRUDEFINITION® DURATION MAX® SHINGLES

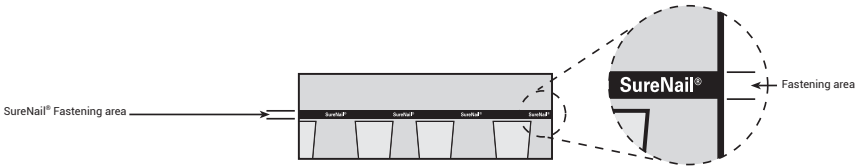

Application Instructions

Before installing this product, check local building codes for their roofing requirements.

These shingles are designed for new or reroofing work over any properly built and supported wood roof deck having adequate nail holding capacity and a smooth surface. Check local building codes.

Precautionary Note:

The manufacturer will not be responsible for problems resulting from any deviation from the recommended application instructions and the following precautions:

Roof Top Loading: Lay shingle bundles flat. Do not bend over the ridge.

Roof Deck: • 6" Minimum roof deck boards • Minimum $\frac{3}{8}$ " plywood • Minimum $\frac{7}{16}$ " OSB

Regardless of deck type used, the roofing installer must:

1. Install the deck material in strict compliance with the deck manufacturer's instructions.
2. Prevent the deck from getting wet before, during and after installation.

Ventilation: Must meet local building codes.

Handling: Use extra care in handling shingles when the temperature is below 40°F.

Shingle Cutting: For best results ensure that all cutting devices are sharp and that when cutting shingles it is best to cut with a quick motion as you pull the roofing knife through the shingle.

Storage: Store in a covered ventilated area at a maximum temperature of 110°F. Bundles should be stacked flat. Protect shingles from weather when stored at the job site. Do not store near steam pipes, radiators, etc.

Fastener Requirement: Use galvanized steel, stainless steel, or aluminum nails minimum 12 gauge shank with $\frac{3}{8}$ " diameter head. Owens Corning Roofing recommends that fasteners comply with ASTM F1667. Check local building codes.

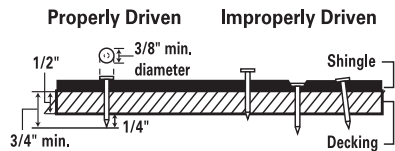

All Fasteners must penetrate at least $\frac{3}{4}$ " into the wood deck or completely through sheathing.

Notice: Owens Corning Roofing recommends the use of nails as the preferred method of attaching shingles to wood decking or other nailable surface.

1 Specialty Eave Flashing: Where required by code.

WeatherLock® underlayment or equivalent eave and flashing membrane applied to a point at least 24" beyond interior wall line. See manufacturers installation instructions. See Fig. 1.

FIG 1 Specialty Eave Flashing

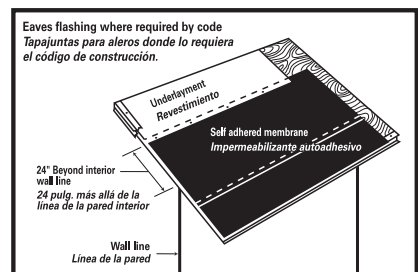

2 Underlayment:

Standard Slope (4" in 12" or more). Application of underlayment, metal drip edges, and ice dam protection: See Fig. 2.

- (A) Apply one layer of underlayment over metal drip edge at eaves. Use only enough fasteners to hold in place.
- (B) Overlap successive courses 2" Overlap course ends 4". Side laps are to be staggered 6' apart.
- (C) Apply metal drip edge over underlayment at rake.

FIG 2 Underlayment Standard Slope

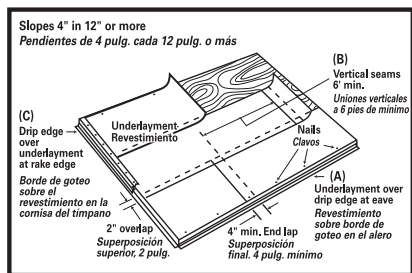

3 Underlayment: Low Slope (2" in 12" to less than 4" in 12").

Application of roofing felt overlapped by 19 inches on each course. See Fig. 3.

- (A) Apply 19" starter strip of underlayment over metal drip edge at eaves. Use only enough fasteners to hold it in place.
- (B) Use 36" strips of underlayment for remaining courses, overlapping each course 19". Side laps are to be staggered 6' apart.
- (C) Apply metal drip edge over underlayment at rake.

Or WeatherLock® self-adhered underlayment or equivalent with a standard overlap of 3 inches and metal drip edge. See Fig. 3A.

FIG 3 Underlayment Low Slope

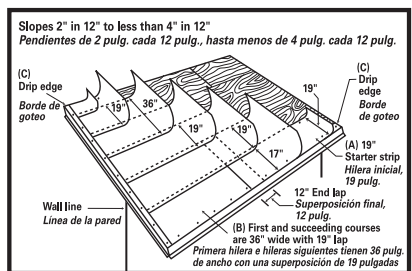
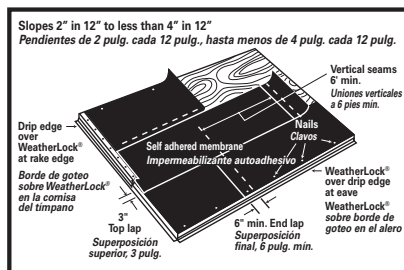

FIG 3A Underlayment Low Slope



4 Shingle Fastening Pattern: Mansard and Steep Slope Fastening Pattern.

Fasteners must be placed in the SureNail® fastening area. See Fig. 4. Six Nail Fastening Pattern. For 6 nail fastening pattern. See Fig. 4A.

Mansard or Steep Slope Fastening Pattern. Place fasteners 6 1/8" from bottom edge to secure both layers of the shingle. Fasteners need to be located 6 1/8" above the edge of the shingle, regardless of whether they are in the granules or the SureNail® fastening area. See Fig. 4B.

Shingle Side View

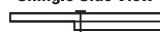

REQUIRED: For slopes exceeding 60 degrees or 21 inches per foot, use six fasteners and four spots of asphalt cement per shingle. Apply immediately; one 1" diameter spot of asphalt cement under each shingle tab. Center asphalt roof cement 2" up from bottom edge of shingle tab.

Roof Cement where required must meet ASTM D4586 Type I or II (Asbestos Free).

FIG 4 Standard Fastening Pattern

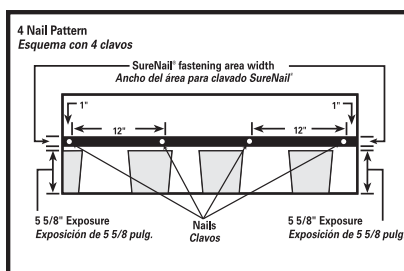

FIG 4A Six Nail Fastening Pattern

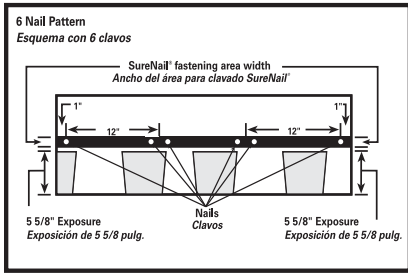
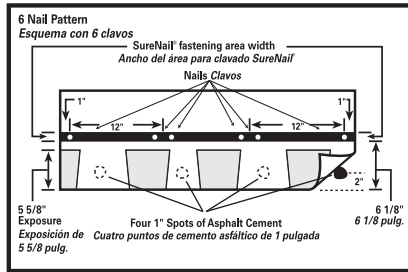

FIG 4B Mansard and Steep Slope Application



5 Shingle Application:

These shingles are applied with a 6½" offset, with 5⅝" exposure, over prepared roof deck, starting at the bottom of the roof and working across and up. This will blend shingles from one bundle into the next and minimize any normal shade variation. Application with offsets of 4" or 5" are also acceptable.

Caution must be exercised to assure that end joints are no closer than 2" from fastener in the shingle below and that side laps are no less than 4" in succeeding courses. Refer to course application steps for specific instructions.

Starter Course:

Use starter roll, starter strip, or trim 5⅝" from the starter course shingle. Trim 6½" off the rake of the starter course shingle and flush with the drip edge along the rake and eaves edge, and continue across the roof. Use 5 fasteners for each shingle, placed 2" to 3" up from eaves edge. See Fig. 5. (If no drip edge is used, shingles must extend a minimum of ½" and no more than 1" from rake and eaves edge.)

First Course:

Apply first course starting with the full shingle even with the starter course. See Fig. 5A.

Fasten securely according to fastening instructions. See Fig. 4.

FIG 5 Shingle Application

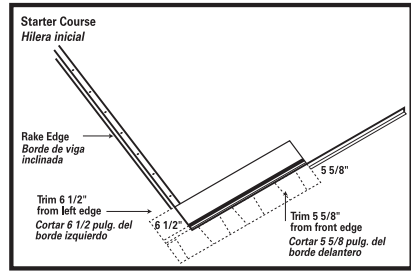

FIG 5A Shingle Application

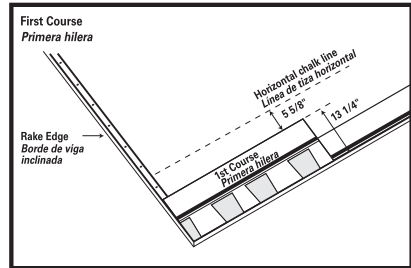

FIG 5B Shingle Application

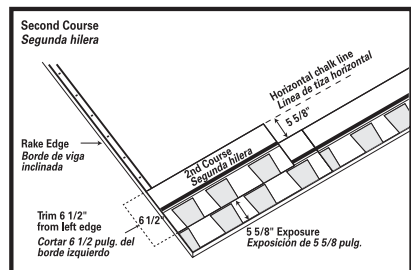
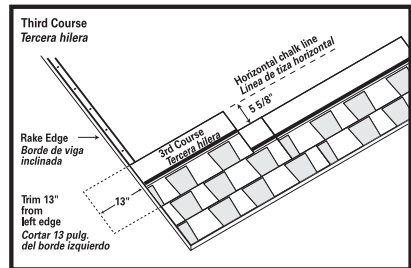

FIG 5C Shingle Application



Second Course:

Remove 6½" from the left end of this shingle and apply the remaining piece over and above the first course shingle and flush with edge of the first course with 5⅝" exposure. See Fig. 5B.

TRUDEFINITION®
DURATION MAX® SHINGLES

Fasten securely according to fastening instructions. See Fig. 4.

FIG 5D Shingle Application

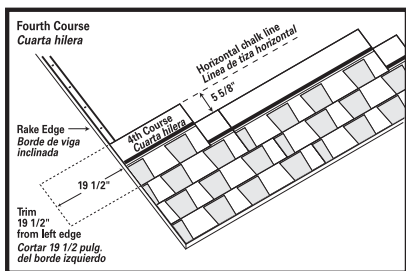

FIG 5E Shingle Application

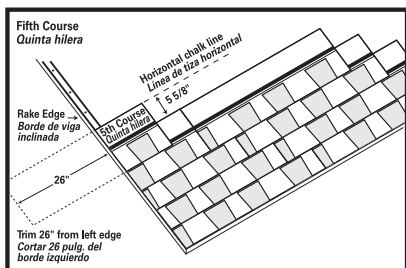

FIG 5F Shingle Application

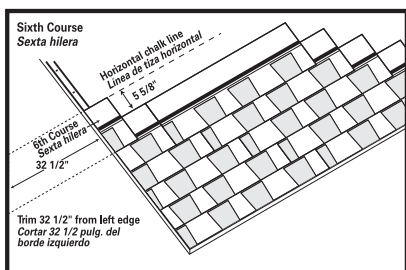
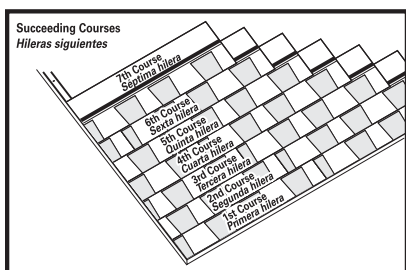

FIG 5G Shingle Application



Third Course:

Remove 13" from the left end of this shingle and apply the remaining piece over and above the second course shingle flush with edge of the second course with 5 5/8" exposure. See Fig. 5C.

Fasten securely according to fastening instructions. See Fig. 4.

Fourth Course:

Remove 19 1/2" from the left end of this shingle and apply the remaining piece over and above the third course shingle and flush with edge of the third course with 5 5/8" exposure. See Fig. 5D.

Fasten securely according to fastening instructions. See Fig. 4.

Fifth Course:

Remove 26" from the left end of this shingle and apply the remaining piece over and above the fourth course shingle and flush with edge of the fourth course with 5 5/8" exposure. See Fig. 5E.

Fasten securely according to fastening instructions. See Fig. 4.

Sixth Course:

Remove 32 1/2" from the left end of this shingle and apply the remaining piece over and above the fifth course shingle and flush with edge of the fifth course with 5 5/8" exposure. See Fig. 5F.

Fasten securely according to fastening instructions. See Fig. 4.

Succeeding Courses:
For succeeding courses, repeat first through sixth course. See Fig. 5G.

6

Valley Construction:

Closed-Cut Valley See Fig. 6.

A closed-cut valley can be used as an alternative to woven or open valley and is applied as follows:

Lay a 36" wide valley liner of self adhered membrane underlayment or equivalent. A 36"- wide minimum 50-lb. roll roofing can also be used as a valley liner.

Lay all shingles on one side of valley and across center line of valley a minimum of 12". Fasten a minimum of 6" away from center line on each side of valley.

Strike a chalk line 2" from the center line of the unshingled side. Apply shingles on the unshingled side up to the chalk line and trim, taking care not to cut the underlying shingles. Clip upper corners of these shingles, cement and fasten.

Both woven and metal valleys are acceptable alternatives.

FIG 6 Closed-Cut Valley Construction

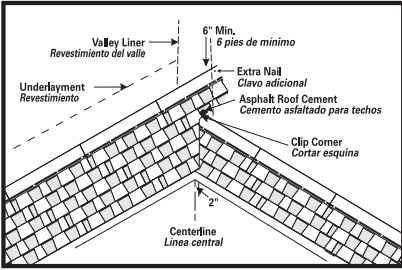

7 **Step Flashing:**
Use 10" long and 2" wider than expected exposure corrosion-resistant metal where roof planes butt against vertical sidewalls or chimneys. See Fig. 7. Check local building codes.

FIG 7 Step Flashing

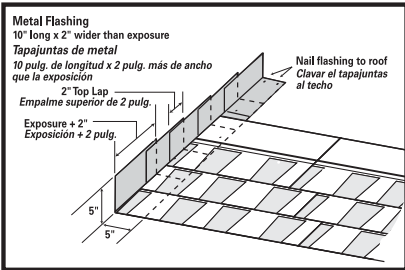

8 **Hip & Ridge Application:**
Use corresponding Owens Corning® Hip & Ridge Shingles to best complement shingle color. Follow specific application instructions as printed on the Hip & Ridge Shingle package. See Fig. 8.

FIG 8 Hip & Ridge Application

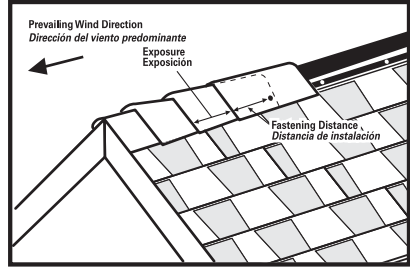

DURATION® PREMIUM SHINGLES

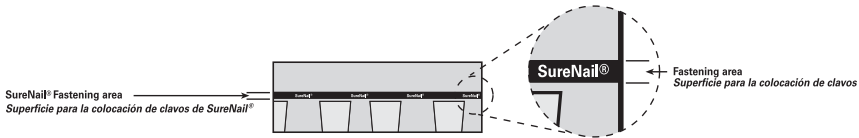

Application Instructions

Before installing this product, check local building codes for their roofing requirements.

These shingles are designed for new or reroofing work over any properly built and supported wood roof deck having adequate nail holding capacity and a smooth surface. Check local building codes.

Precautionary Note:

The manufacturer will not be responsible for problems resulting from any deviation from the recommended application instructions and the following precautions:

Roof Top Loading: Lay shingle bundles flat. Do not bend over the ridge.

Roof Deck: • 6" Minimum roof deck boards
• Minimum 3/8" plywood • Minimum 7/16" OSB

Regardless of deck type used, the roofing installer must:

1. Install the deck material in strict compliance with the deck manufacturer's instructions.
2. Prevent the deck from getting wet before, during and after installation.

Ventilation: Must meet local building codes.

Handling: Use extra care in handling shingles when the temperature is below 40°F.

Shingle Cutting: For best results ensure that all cutting devices are sharp and that when cutting shingles it is best to cut with a quick motion as you pull the roofing knife through the shingle.

Storage: Store in a covered ventilated area at a maximum temperature of 110°F. Bundles should be stacked flat. Protect shingles from weather when stored at the job site. Do not store near steam pipes, radiators, etc.

Fastener requirement: Use galvanized steel, stainless steel, or aluminum nails minimum 12-gauge shank with 3/8"

diameter head. Owens Corning Roofing recommends that fasteners comply with ASTM F1667. Check local building codes.

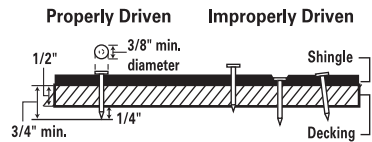

All Fasteners must penetrate at least 3/4" into the wood deck or completely through sheathing.

Notice: Owens Corning Roofing recommends the use of nails as the preferred method of attaching shingles to wood decking or other nailable surface.

1 Specialty Eave Flashing:

Where required by code.

WeatherLock® underlayment or equivalent eave and flashing membrane applied to a point at least 24" beyond interior wall line. See manufacturer's installation instructions. See Fig. 1.

Fig. 1 Specialty Eave Flashing
Tapajuntas especial para aleros

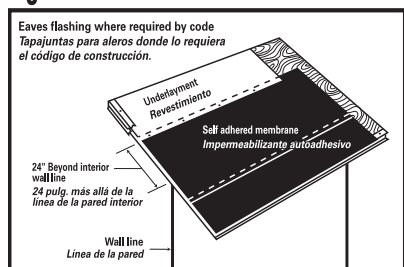

2 Underlayment:

Standard Slope (4" in 12" or more)

Application of underlayment, metal drip edges, and ice dam protection: See Fig. 2.

(A) Apply one layer of underlayment over metal drip edge at eaves. Use only enough fasteners to hold in place.

(B) Overlap successive courses 2". Overlap course ends 4". Side laps are to be staggered 6' apart.

(C) Apply metal drip edge over underlayment at rake.

Fig. 2 Underlayment Standard Slope
Pendiente estándar del revestimiento

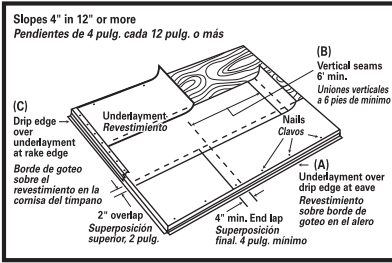

3 Underlayment:

Low Slope (2" in 12" to less than 4" in 12")

Application of roofing felt overlapped by 19 inches on each course. See Fig. 3.

(A) Apply 19" starter strip of underlayment over metal drip edge at eaves. Use only enough fasteners to hold it in place.

(B) Use 36" strip of underlayment for remaining courses, overlapping each course 19". Side laps are to be staggered 6' apart.

(C) Apply metal drip edge over underlayment at rake.

Or WeatherLock® self-adhered underlayment or equivalent with a standard overlap of 3 inches and metal drip edge. See Fig. 3A.

Fig. 3 Underlayment Low Slope
Pendiente baja del revestimiento

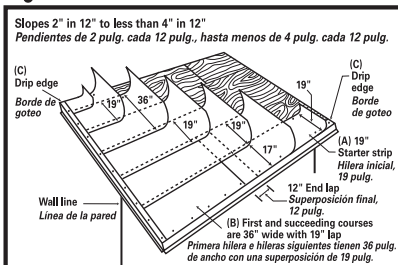
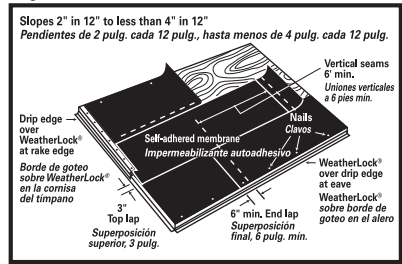

Fig. 3A Underlayment Low Slope
Pendiente baja del revestimiento



4 Shingle Fastening Pattern:

Standard Fastening Pattern.

Fasteners must be placed in the SureNail® fastening area. See Fig. 4.

Six Nail Fastening Pattern.

For 6 nail fastening pattern. See Fig. 4A.

Mansard or Steep Slope Fastening Pattern.

Place fasteners 6 1/8" from bottom edge to secure both layers of the shingle. Fasteners need to be located 6 1/8" above the butt edge of the shingle, regardless of whether they are in the granules or the SureNail® fastening area. See Fig. 4B.

Shingle Side View



REQUIRED: For slopes exceeding 60 degrees or 21" per foot, use six fasteners and four spots of asphalt cement per shingle. Apply immediately; one 1" diameter spot of asphalt cement **under** each shingle tab. Center asphalt roof cement 2" up from bottom edge of shingle tab.

Roof Cement where required must meet ASTM D4586 Type I or II (Asbestos Free).

Fig. 4 Standard Fastening Pattern
Esquema de instalación estándar

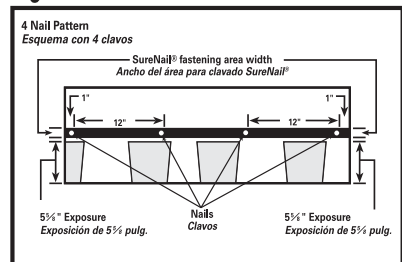

Fig. 4A Six Nail Fastening Pattern
Esquema de instalación con seis clavos

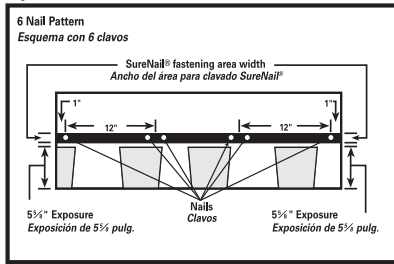
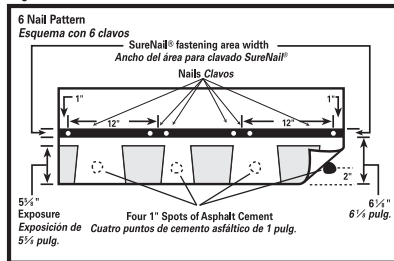

Fig. 4B Mansard or Steep Slope Fastening Pattern
Esquema de instalación en pendientes pronunciadas o mansardas



5 Shingle Application:

These shingles are applied with a 6½" offset, with 5½" exposure, over prepared roof deck, starting at the bottom of the roof and working across and up. This will blend shingles from one bundle into the next and minimize any normal shade variation. Application with offsets of 4" or 5" are also acceptable.

Caution must be exercised to assure that end joints are no closer than 2" from fastener in the shingle below and that side laps are no less than 4" in succeeding courses. Refer to course application steps for specific instructions.

Starter Course:

Use starter roll or trim 5½" from the starter course shingle. Trim 6½" off the rake of the starter course shingle and flush with the drip edge along the rake and eaves edge, and continue across the roof. Use 5 fasteners for each shingle, placed 2" to 3" up from eaves edge. See Fig. 5. (If no drip edge is used, shingles must extend a minimum of ½" and no more than 1" from rake and eaves edge.)

Fig. 5 Shingle Application
Instalación de tejas

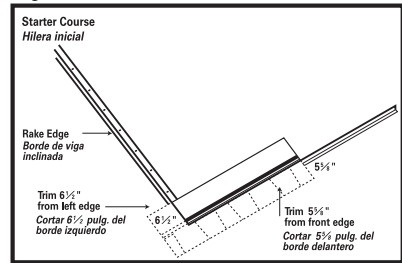

Fig. 5A Shingle Application
Instalación de tejas

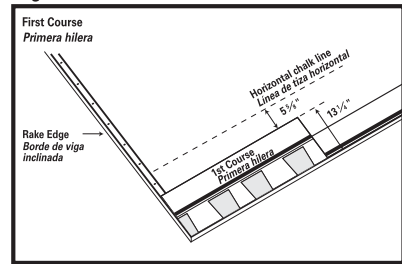

Fig. 5B Shingle Application
Instalación de tejas

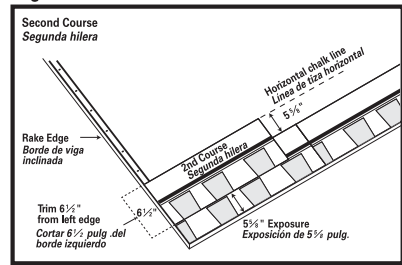
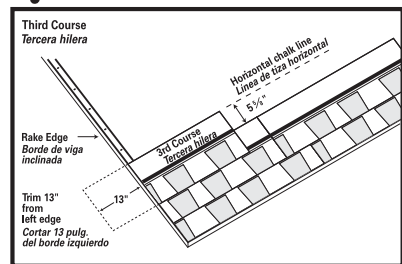

Fig. 5C Shingle Application
Instalación de tejas



First Course:

Apply first course starting with the full shingle even with the starter course. See Fig. 5A.

Fasten securely according to fastening instructions. See Fig. 4.

Second Course:

Remove 6½" from the left end of this shingle and apply the remaining piece over and above the first course shingle and flush with edge of the first course with 5⅝" exposure. See Fig. 5B.

Fasten securely according to fastening instructions. See Fig. 4.

Third Course:

Remove 13" from the left end of this shingle and apply the remaining piece over and above the second course shingle flush with edge of the second course with 5⅝" exposure. See Fig. 5C.

Fasten securely according to fastening instructions. See Fig. 4.

Fourth Course:

Remove 19½" from the left end of this shingle and apply the remaining piece over and above the third course shingle and flush with edge of the third course with 5⅝" exposure. See Fig. 5D.

Fasten securely according to fastening instructions. See Fig. 4.

Fifth Course:

Remove 26" from the left end of this shingle and apply the remaining piece over and above the fourth course shingle and flush with edge of the fourth course with 5⅝" exposure. See Fig. 5E.

Fasten securely according to fastening instructions. See Fig. 4.

Sixth Course:

Remove 32½" from the left end of this shingle and apply the remaining piece over and above the fifth course shingle and flush with edge of the fifth course with 5⅝" exposure. See Fig. 5F.

Fasten securely according to fastening instructions. See Fig. 4.

Succeeding Courses:

For succeeding courses, repeat first through sixth course. See Fig. 5G.

Fig. 5D Shingle Application
Instalación de tejas

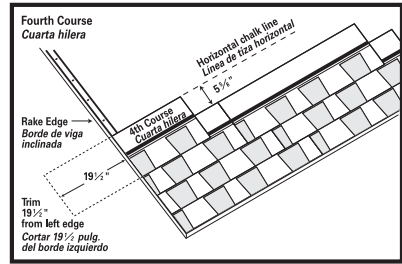

Fig. 5E Shingle Application
Instalación de tejas

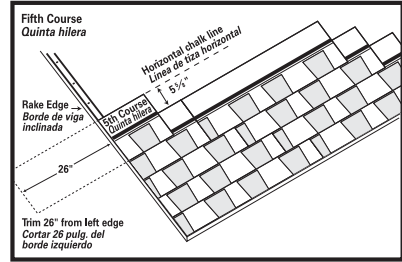

Fig. 5F Shingle Application
Instalación de tejas

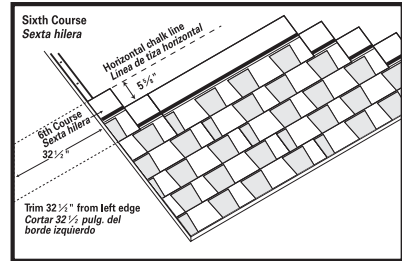
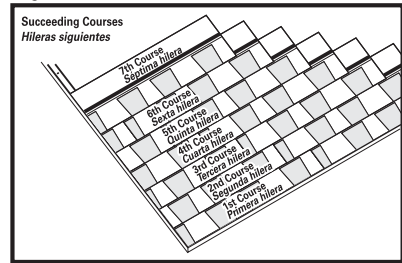

Fig. 5G Shingle Application
Instalación de tejas



6 Valley Construction:

Closed-Cut Valley See Fig. 6.

A closed-cut valley can be used as an alternative to woven or open valley and is applied as follows:

Lay a 36" wide valley liner of self-adhered membrane underlayment or equivalent. A 36" wide minimum 50 lb. roll roofing can also be used as a valley liner.

Lay all shingles on one side of valley and across center line of valley a minimum of 12". Fasten a minimum of 6" away from center line on each side of valley.

Strike a chalk line 2" from the center line of the unshingled side. Apply shingles on the unshingled side up to the chalk line and trim, taking care not to cut the underlying shingles. Clip upper corners of these shingles, cement and fasten.

Both woven and metal valleys are acceptable alternatives.

Fig. 6 Closed-Cut Valley Construction
Construcción del valle con corte cerrado

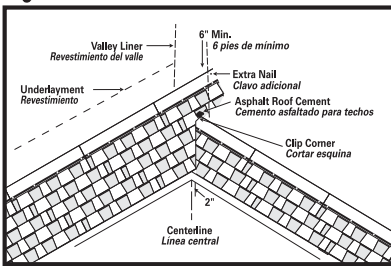

7 Step Flashing:

Use 10" long and 2" wider than expected exposure corrosion-resistant metal where roof planes butt against vertical sidewalls or chimneys. See Fig. 7. Check local building codes.

Fig. 7 Step Flashing
Tapajuntas escalonado

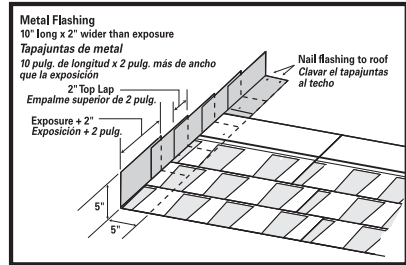

8 Hip & Ridge Application:

Use corresponding Owens Corning® Hip & Ridge shingles to best complement shingle color. Follow specific application instructions as printed on the Hip & Ridge shingle package. See Fig. 8.

Fig. 8 Hip & Ridge Application
Instalación de caballetes y cumbresas

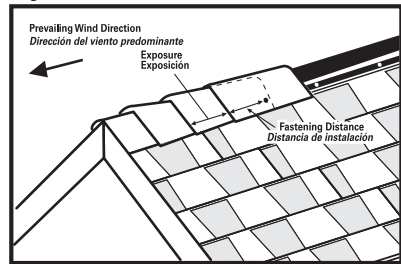

TRUDEFINITION® WEATHERGUARD® HP SHINGLES

Application Instructions

The manufacturer will not be responsible for problems resulting from any deviation from the application instructions and the following precautions:

Precautionary Notes

- The existing roof covering must be removed before installing WeatherGuard® HP.
- Use of shingle-over ridge vent will affect the impact resistance classification of the WeatherGuard® HP Hip & Ridge; use off-ridge ventilation products as an alternative.
- Spacing between the decking at the ridge should not be more than ¼" because it could affect the impact resistance classification.
- WeatherGuard® HP Hip & Ridge Shingles must be used.

CAUTION: Due to the aggressive nature of our shingle sealant strip, please note the following: To avoid shingles from sticking in hot sun, do not have the sealant strip make contact with various objects on the roof, until you are ready to nail the shingle in place.

Roof Top Loading: Lay shingle bundles flat. Do not bend over the ridge.

Roof Deck: • 6" Minimum roof deck boards
• Minimum ¾" plywood • Minimum 7/16" OSB

Regardless of deck type used, the roofing installer must:

1. Install the deck material in strict compliance with the deck manufacturer's instructions.
2. Prevent the deck from getting wet before, during and after installation.

Ventilation: Must meet local building codes.

Handling: Use extra care in handling shingles when the temperature is below 40°F.

Storage: Store in a covered ventilated area at a maximum temperature of 110°F. Bundles should be stacked flat. Protect shingles from weather when stored at the job site. Do not store near steam pipes, radiators, etc.

Fastener requirement: Use galvanized steel, stainless steel, or aluminum nails

minimum 12 gauge shank with ⅜" diameter head. Owens Corning Roofing recommends that fasteners comply with ASTM F1667. Check local building codes.

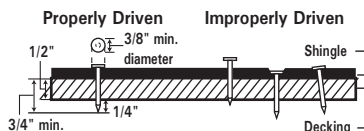

All Fasteners must penetrate at least ¾" into the wood deck or completely through sheathing.

Notice: Owens Corning Roofing recommends the use of nails as the preferred method of attaching shingles to wood decking or other nailable surface.

1 Specialty Eave Flashing:

Where required by code.

WeatherLock® underlayment or equivalent eave and flashing membrane applied to a point at least 24" beyond interior wall line. See manufacturers installation instructions. See Fig. 1.

Fig. 1 Specialty Eave Flashing
Tapajuntas especial para aleros

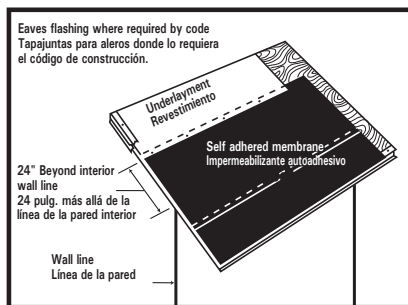

2 Underlayment:

Standard Slope (4" in 12" or more)

Application of underlayment, metal drip edges, and ice dam protection: See Fig. 2.

(A) Apply one layer of underlayment over metal drip edge at eaves. Use only enough fasteners to hold in place.

(B) Overlap successive courses 2". Overlap course ends 4". Side laps are to be staggered 6' apart.

(C) Apply metal drip edge over underlayment at rake.

Fig. 2 Underlayment Standard Slope
Revestimiento para pendientes estándar

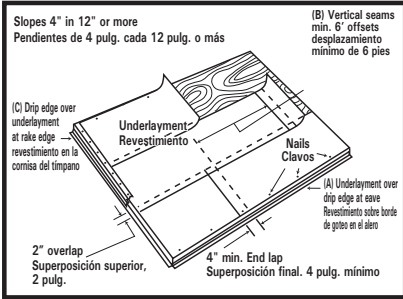

3 Underlayment:

Low Slope (2" in 12" to less than 4" in 12")

Application of underlayment, metal drip edges, and ice dam protection:
See Fig. 3.

(A) Apply 19" starter strip of underlayment over metal drip edge at eaves. Use only enough fasteners to hold it in place.

(B) Use 36" strip of underlayment for remaining courses, overlapping each course 19". Side laps are to be staggered 6' apart.

(C) Apply metal drip edge over underlayment at rake.

Or WeatherLock® self-adhered underlayment or equivalent with a standard over lap of 3 inches and metal drip edge. See Fig. 3A.

Fig. 3 Underlayment Low Slope
Revestimiento para pendientes bajas

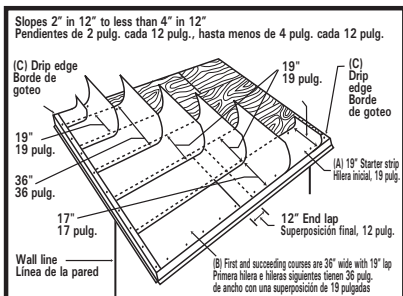
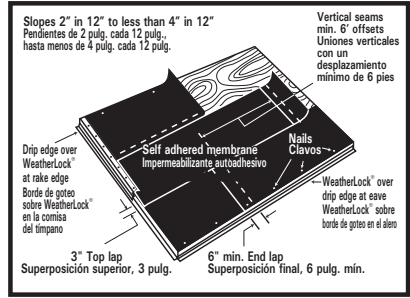

Fig. 3A Underlayment Low Slope
Revestimiento para pendientes bajas



4 Shingle Fastening:

Nails **MUST** penetrate both layers of the shingle as shown in the diagram below.

Shingle Side View



Four Nail Pattern for 110 mph

Use four fasteners placed 6 1/8" from bottom edge to secure both layers of the shingle. See Fig. 4.

Six Nail Pattern for 130 mph

Use six fasteners placed 6 1/8" from bottom edge to secure both layers of the shingle. See Fig. 4A.

Mansard or Steep Slope Fastening Pattern.

Place fasteners 6 1/8" from bottom edge to secure both layers of the shingle. See Fig. 4B.

REQUIRED: For slopes exceeding 60 degrees or 21 inches per foot, use six fasteners and four spots of asphalt roof cement per shingle. Apply immediately; one 1" diameter spot of asphalt roof cement under each shingle tab. Center asphalt roof cement 2" up from bottom edge of shingle tab. See Fig. 4B.

Asphalt Roof Cement where required must meet ASTM D-4586 Type I or II (Asbestos Free).

Note: Please be aware that excessive amounts of asphalt roof cement could blister the shingle.

Fig. 4 Four Nail Pattern for 110 mph
Esquema de instalación con 4 clavos para vientos de 110 mph

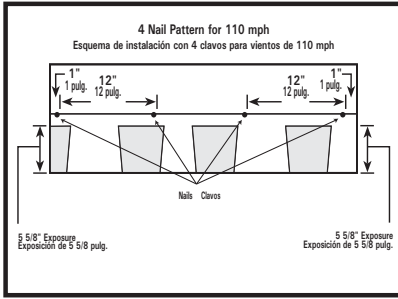

Fig. 4A Six Nail Pattern for 130 mph
Esquema de instalación con 6 clavos para vientos de 130 mph

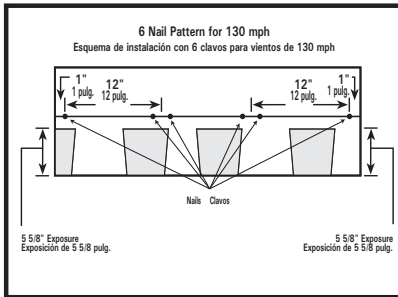
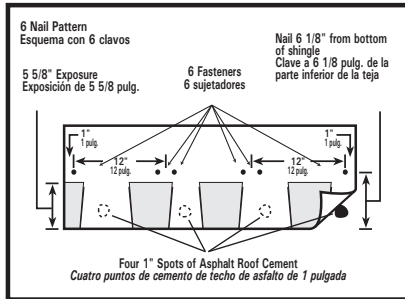

Fig. 4B Mansard or Steep Slope Fastening Pattern
Esquema de instalación en pendientes pronunciadas o mansardas



5 Shingle Application:

These shingles are applied with a 6 1/2" offset, with 5 5/8" exposure, over prepared roof deck, starting at the bottom of the roof and working across and up. This will blend shingles from one bundle into the next and minimize any normal shade variation. Application with offsets of 4" or 8" are also acceptable.

Caution must be exercised to assure that end joints are no closer than 2"

from fastener in the shingle below and that side laps are no less than 4" in succeeding courses. Refer to course application steps for specific instructions.

Fig. 5 Shingle Application
Instalación de tejas

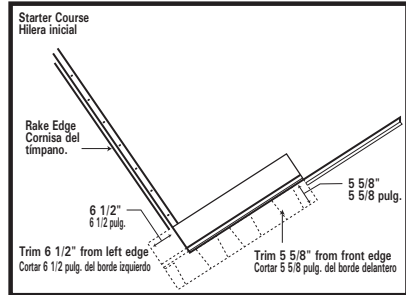
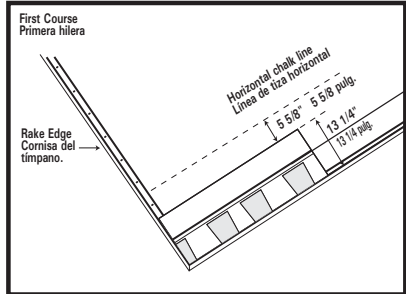

Fig. 5A Shingle Application
Instalación de tejas



Starter Course:

Use an Owens Corning Roofing Starter product or trim 5 5/8" from the starter course shingle. Trim 6 1/2" off the rake of the starter course shingle and flush with the drip edge along the rake and eaves edge, and continue across the roof. Use 5 fasteners for each shingle, placed 2" to 3" up from eaves edge. See Fig. 5. (If no drip edge is used, shingles must extend a minimum of 1/2" and no more than 1" from rake and eaves edge.)

First Course:

Apply first course starting with the full shingle even with the starter course. See Fig. 5A.

Fasten securely according to fastening instructions. See Fig. 4 or 4A.

Second Course:

Remove 6 1/2" from the left end of this shingle and apply the remaining

piece over and above the first course shingle and flush with edge of the first course with $5\frac{5}{8}$ " exposure. See Fig. 5B.

Fasten securely according to fastening instructions. See Fig. 4 or 4A.

Fig. 5B Shingle Application
Instalación de tejas

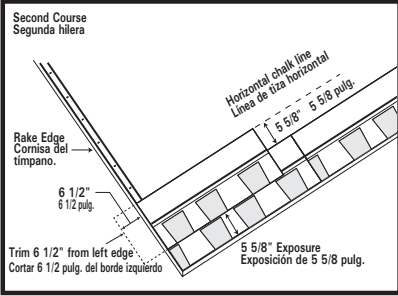

Third Course:

Remove 13" from the left end of this shingle and apply the remaining piece over and above the second course shingle flush with edge of the second course with $5\frac{5}{8}$ " exposure. See Fig. 5C.

Fasten securely according to fastening instructions. See Fig. 4 or 4A.

Fig. 5C Shingle Application
Instalación de tejas

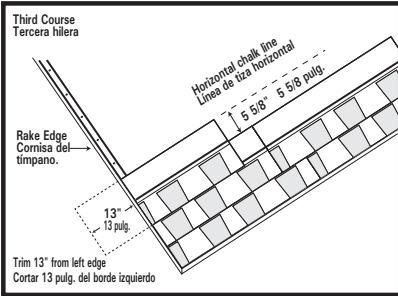

Fourth Course:

Remove 19½" from the left end of this shingle and apply the remaining piece over and above the third course shingle and flush with edge of the third course with $5\frac{5}{8}$ " exposure. See Fig. 5D.

Fasten securely according to fastening instructions. See Fig. 4 or 4A

Fifth Course:

Remove 26" from the left end of this shingle and apply the remaining piece over and above the fourth course

shingle and flush with edge of the fourth course with $5\frac{5}{8}$ " exposure. See Fig. 5E.

Fasten securely according to fastening instructions. See Fig. 4 or 4A.

Fig. 5D Shingle Application
Instalación de tejas

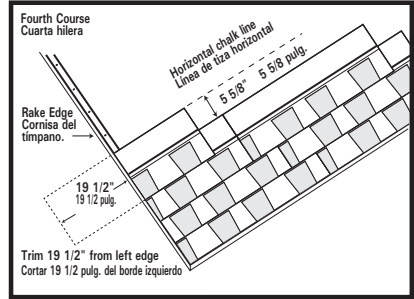

Fig. 5E Shingle Application
Instalación de tejas

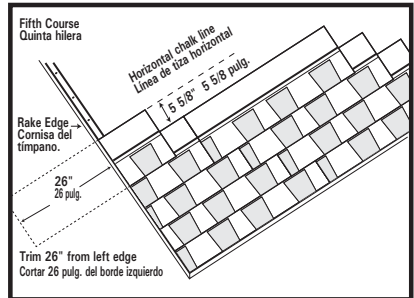
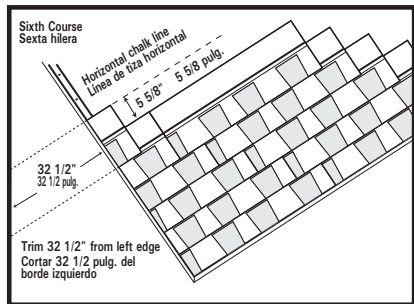

Fig. 5F Shingle Application
Instalación de tejas



Sixth Course:

Remove 32½" from the left end of this shingle and apply the remaining piece over and above the fifth course shingle and flush with edge of the fifth course with $5\frac{5}{8}$ " exposure. See Fig. 5F.

Fasten securely according to fastening instructions. See Fig. 4 or 4A.

Succeeding Courses:

For succeeding courses, repeat first through sixth course. See Fig. 5G.

Fig. 5G Shingle Application
Instalación de tejas

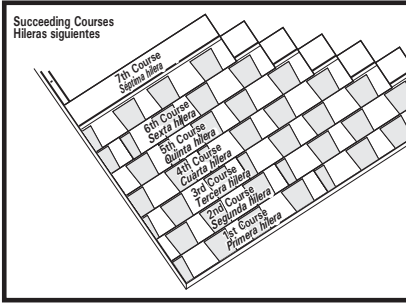

6 Valley Construction:

Closed-Cut Valley See Fig. 6.

A closed-cut valley can be used as an alternative to woven and open valley and is applied as follows: Lay a 36" wide valley liner of self adhered membrane underlayment or equivalent. A 36" wide minimum 50 lb. smooth surface roll roofing can also be used as a valley liner. Lay all shingles on one side of valley and across center line of valley a minimum of 12". Fasten a minimum of 6" away from center line on each side of valley. Strike a chalk line 2" from the center line of the unshingled side. Apply shingles on the unshingled side up to the chalk line and trim, taking care not to cut the underlying shingles. Clip upper corners of these shingles, cement and fasten. Both woven and metal valleys are acceptable alternatives.

Fig. 6 Closed-Cut Valley Construction
Construcción del valle con corte cerrado

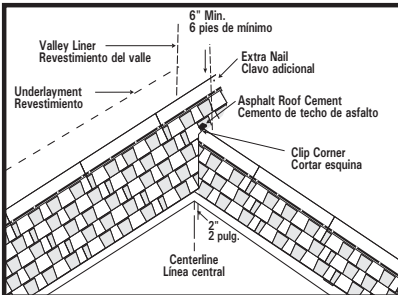

7 Step Flashing:

Use 10" long and 2" wider than expected exposure corrosion-resistant metal where roof planes butt against vertical sidewalls or chimneys. Check local building codes. See Fig. 7.

Fig. 7 Step Flashing
Tapajuntas escalonado

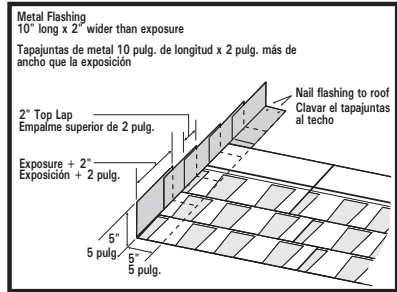

8 Hip & Ridge Application:

Use corresponding Owens Corning® WeatherGuard® HP Hip & Ridge shingles to best complement shingle color. Follow specific application instructions as printed on the hip & ridge shingle package. See Fig. 8.

Fig. 8 Hip & Ridge Application
Instalación de caballetes y cumbresras

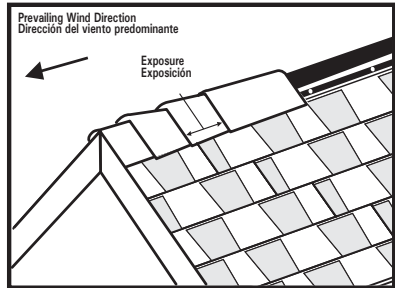

TRUDEFINITION® DURATION FLEX™ SHINGLES

Application Instructions

Before installing this product, check local building codes for roofing requirements.

These shingles are designed for new or reroofing work over any properly built and supported wood roof deck having adequate nail holding capacity and a smooth surface. Must comply with local building codes.

Precautionary Note:

The manufacturer will not be responsible for problems resulting from any deviation from the application instructions and the following precautions:

Roof Top Loading: Lay shingle bundles flat. Do not bend over the ridge.

Roof Deck: • 6" Minimum roof deck boards
• Minimum $\frac{3}{8}$ " plywood • Minimum $\frac{7}{16}$ " OSB, sheathing spaced minimum $\frac{1}{8}$ inch and maximum $\frac{1}{4}$ inch.

Regardless of deck type used, the roofing installer must:

1. Install the deck material in strict compliance with the deck manufacturer's instructions.
2. Prevent the deck from getting wet before, during and after installation.

Ventilation: Must comply with local building codes.

Handling: Use extra care in handling shingles when the temperature is below 40°F.

Storage: Store in a covered ventilated area at a maximum temperature of 110°F. Bundles should be stacked flat. Protect shingles from weather when stored at the job site. Do not store near steam pipes, radiators, etc.

Fastener requirement: Use galvanized steel, stainless steel, or aluminum nails minimum 12 gauge shank with $\frac{3}{8}$ inch diameter head. Owens Corning Roofing recommends that fasteners comply with ASTM F 1667. Must comply with local building codes.

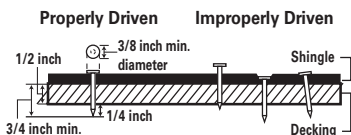

All Fasteners must penetrate at least $\frac{3}{4}$ inch into the wood deck or completely through the deck by a minimum of $\frac{1}{4}$ inch.

Notice: Owens Corning Roofing requires the use of nails as the preferred method of attaching shingles to wood decking.

1 Self-Adhered Ice & Water Barrier:

Use Owens Corning® Self-Adhered Ice & Water Barrier on the eaves in all regions of the county where roofs have had a history of ice and water backup. Apply starting at the eave edge and extend upslope a minimum of 24 inches from the interior wall line or as required by local codes. See Fig. 1.

Fig. 1 Self-Adhered Ice & Water Barrier
Barrera autoadhesiva resistente al hielo y al agua

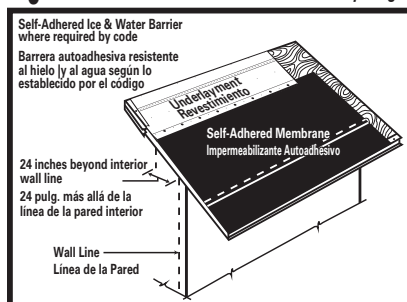

2 Synthetic Underlayment:

Standard Slopes 4:12 and Greater

Use an Owens Corning® Synthetic Underlayment or equivalent underlayment meeting ASTM D 226, D4869 or D6757. Follow underlayment manufacturer's application instructions and local building codes. See Fig. 2.

Fig. 2 Synthetic Underlayment Standard Slope
Membrana impermeabilizante sintética - Pendiente estándar

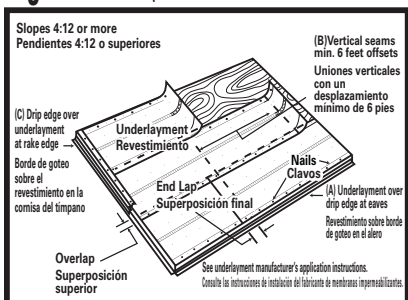

3 Synthetic Underlayment:
Low Slope 2:12 to Less than 4:12
Use an Owens Corning® Synthetic Underlayment meeting ASTM D 226, D4869 or D6757. Underlayment must be installed per the manufacturer's application instruction and local building codes. Each underlayment course must be overlapped a minimum of 1/2 the width of the underlayment plus 1 inch. See Fig. 3.

Or Owens Corning® Self-Adhered Ice & Water Barrier or equivalent with a standard overlap of 3 inches and metal drip edge. See Fig. 3A.

Note: See Technical Bulletin for felt application

Fig. 3 Synthetic Underlayment Low Slope
Membrana impermeabilizante sintética - Pendiente baja

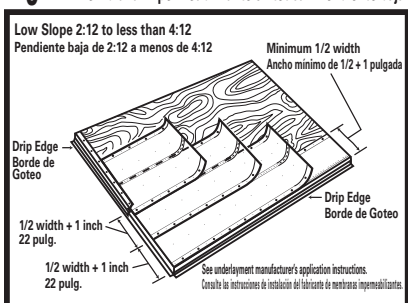
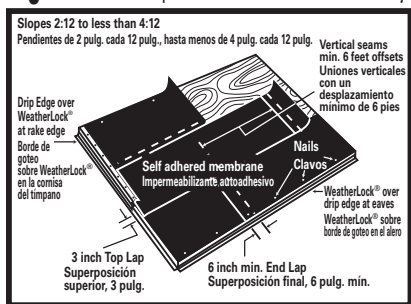

Fig. 3A WeatherLock® Underlayment Low Slope
Membrana impermeabilizante WeatherLock® - Pendiente baja



4 Shingle Fastening Pattern:
Standard Fastening Pattern

Fasteners must be placed in the SureNail® Technology fastening area. See Fig. 4.

Six Nail Pattern

For 6 nail fastening pattern. See Fig. 4A.

Mansard or Steep Slope Fastening Pattern.

Place fasteners 6 1/8 inches from bottom edge to secure both layers of the shingle. Fasteners need to be located 6 1/8 inches above the butt edge of the shingle, regardless of whether they are in the granules or the SureNail® Technology fastening area. See Fig. 4B.

Shingle Side View



REQUIRED: For slopes exceeding 60 degrees or 21 inches per foot, use six fasteners and four spots of asphalt roof cement per shingle. Apply immediately; one 1 inch diameter spot of asphalt roof cement under each shingle tab. Center asphalt roof cement 2 inches up from bottom edge of shingle tab. See Fig. 4B.

Asphalt Roof Cement where required must meet ASTM D4586 Type I or II (Asbestos Free).

Note: Please be aware that excessive amounts of asphalt roof cement could blister the shingle.

Fig. 4 Standard Fastening Pattern
Esquema de instalación estándar

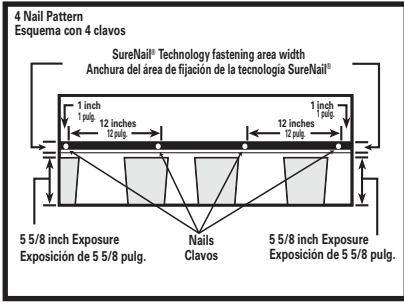

Fig. 4A Six Nail Fastening Pattern
Esquema de instalación con seis clavos

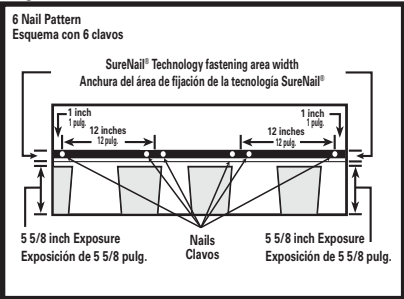
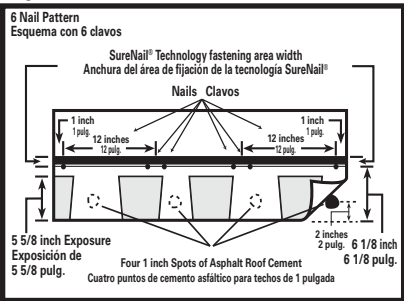

Fig. 4B Mansard or Steep Slope Fastening Pattern
Esquema de instalación en pendientes pronunciadas o mansardas



5 Shingle Application:

These shingles are applied with a 6 1/2 inch offset, with 5 5/8 inch exposure, over prepared roof deck, starting at the bottom of the roof and working across and up. This will blend shingles from one bundle into the next and minimize any normal shade variation. Application with offsets of 4 inches or 8 inches are also acceptable.

Caution must be exercised to assure that end joints are no closer than 2 inches from fastener in the shingle below and that side laps are offset no less than 4 inches in succeeding

courses. Refer to course application steps for specific instructions.

Fig. 5 Starter Strip Shingle Eaves Application
Aplicación de las tejas para la hilera inicial en el alero

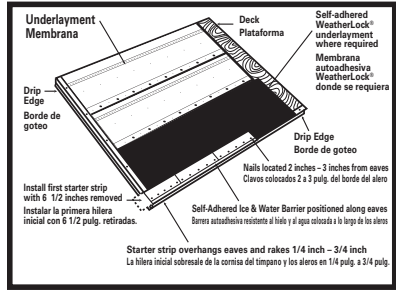

Fig. 5A Shingle Application
Instalación de tejas

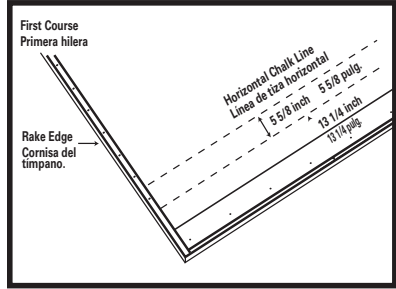

Fig. 5B Shingle Application
Instalación de tejas

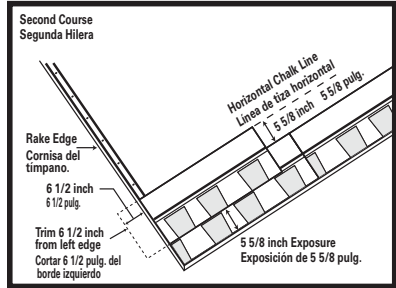

Fig. 5C Shingle Application
Instalación de tejas

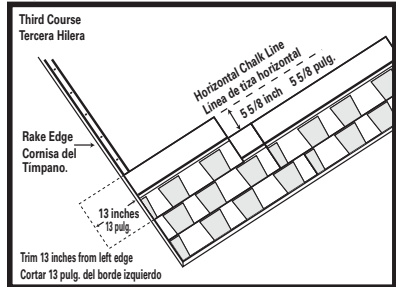

Fig. 5D Shingle Application
Instalación de tejas

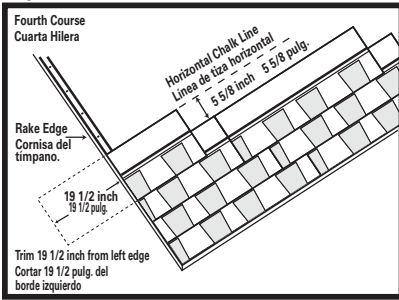

Fig. 5E Shingle Application
Instalación de tejas

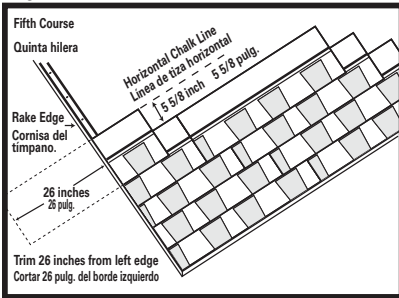

Fig. 5F Shingle Application
Instalación de tejas

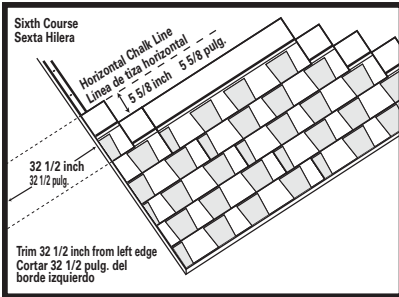
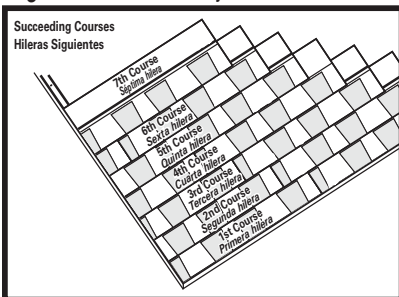

Fig. 5G Shingle Application
Instalación de tejas



Starter Course:

Use an Owens Corning® Starter product. Trim 6½ inches off the rake of the starter course shingle and flush with the drip edge along the rake and eaves edge, and continue across the roof. Use 5 fasteners for each shingle, placed 2 to 3 inches up from eaves edge. See Fig. 5. **If no drip edge is used, shingles must extend a minimum of ½ inch and no more than 1 inch from rake and eaves edge.**

First Course:

Apply first course starting with the full shingle even with the starter course. See Fig. 5A.

Fasten securely according to fastening instructions. See Fig. 4.

Second Course:

Remove 6½ inches from the left end of this shingle and apply the remaining piece over and above the first course shingle and flush with edge of the first course with 5⅝ inch exposure. See Fig. 5B.

Fasten securely according to fastening instructions. See Fig. 4.

Third Course:

Remove 13 inches from the left end of this shingle and apply the remaining piece over and above the second course shingle flush with edge of the second course with 5⅝ inch exposure. See Fig. 5C.

Fasten securely according to fastening instructions. See Fig. 4.

Fourth Course:

Remove 19½ inches from the left end of this shingle and apply the remaining piece over and above the third course shingle and flush with edge of the third course with 5⅝ inch exposure. See Fig. 5D.

Fasten securely according to fastening instructions. See Fig. 4.

Fifth Course:

Remove 26 inches from the left end of this shingle and apply the remaining piece over and above the fourth course shingle and flush with edge of the fourth course with 5⅝ inch exposure. See Fig. 5E.

Fasten securely according to fastening instructions. See Fig. 4.

Sixth Course:

Remove 32½ inches from the left end of this shingle and apply the remaining piece over and above the fifth course shingle and flush with edge of the fifth course with 5½ inch exposure. See Fig. 5F.

Fasten securely according to fastening instructions. See Fig. 4.

Succeeding Courses:

For succeeding courses, repeat first through sixth course. See Fig. 5G.

6 Valley Construction:

Closed-Cut Valley See Fig. 6.

A closed-cut valley can be used as an alternative to woven and open valley and is applied as follows: Lay a 36 inch wide valley liner of self adhered membrane underlayment or equivalent. A 36 inch wide minimum 50 lb. smooth surface roll roofing can also be used as a valley liner. Lay all shingles on one side of valley and across center line of valley a minimum of 12 inches. Fasten a minimum of 6 inches away from center line on each side of valley. Strike a chalk line 2 inches from the center line of the unshingled side. Apply shingles on the unshingled side up to the chalk line and trim, taking care not to cut the underlying shingles. Clip upper corner of these shingles and install a 3 to 4 inch wide, continuous bead of roofing cement. Press shingles firmly into cement. Both woven and metal valleys are acceptable alternatives.

Fig. 6 Closed-Cut Valley Construction
Construcción del valle con corte cerrado

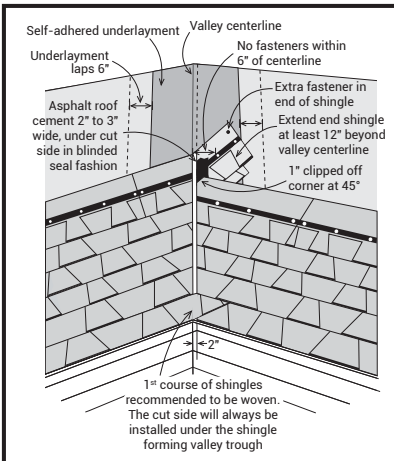

For California-Cut Valley, see Technical Bulletin at www.owenscorning.com.

7 Step Flashing:

Use 10 inches long and 2 inches wider than expected exposure corrosion-resistant metal where roof planes butt against vertical sidewalls or chimneys. Check local building codes. For additional flashing details, go to www.owenscorning.com. See Fig. 7.

Fig. 7 Step Flashing
Tapajuntas escalonado

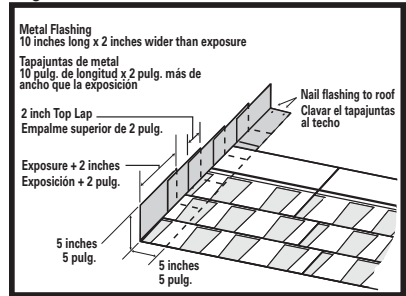

8 Hip & Ridge Application:

Use corresponding Owens Corning® Hip & Ridge shingles to best complement shingle color. Follow specific application instructions as printed on the Hip & Ridge shingle package. See Fig. 8.

Fig. 8 Hip & Ridge Application
Instalación de caballetes y cumbreras

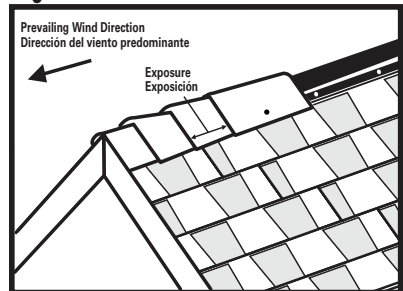

OAKRIDGE® / TRUDEFINITION® OAKRIDGE® SHINGLES

Application Instructions

Before installing this product, check local building codes for their roofing requirements.

These shingles are designed for new or re-roofing work over any properly built and supported wood roof deck having adequate nail holding capacity and a smooth surface. Check local building codes.

Precautionary Note:

The manufacturer will not be responsible for problems resulting from any deviation from the recommended application instructions and the following precautions:

Roof Top Loading: Lay shingle bundles flat. Do not bend over the ridge.

Roof Deck: • 6" Minimum roof deck boards
• Minimum 3/8" plywood • Minimum 7/16" OSB

Regardless of deck type used, the roofing installer must:

1. Install the deck material in strict compliance with the deck manufacturer's instructions.
2. Prevent the deck from getting wet before, during and after installation.

Ventilation: Must meet local building codes.

Handling: Use extra care in handling shingles when the temperature is below 40°F.

Storage: Store in a covered ventilated area at a maximum temperature of 110°F. Bundles should be stacked flat. Protect shingles from weather when stored at the job site. Do not store near steam pipes, radiators, etc.

Fastener requirement: Use galvanized steel, stainless steel, or aluminum nails minimum 12 gauge shank with 3/8" diameter head. Owens Corning Roofing recommends that fasteners comply with ASTM F 1667. Check local building codes.

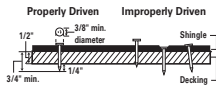

All Fasteners must penetrate at least 3/16" into the wood deck or completely through sheathing.

Notice: Owens Corning Roofing recommends the use of nails as the preferred method of attaching shingles to wood decking or other nailable surface.

1 Ice Dam Protection:

Use Owens Corning® Self-Adhered Ice & Water Barrier on the eaves in all regions of the county where roofs have had a history of ice and water backup.

WeatherLock® underlayment or equivalent eave and flashing membrane applied to a point at least 24" beyond interior wall line. See manufacturer's installation instructions. See Fig. 1.

Fig. 1 Ice Dam Protection
Tapajuntas especial para aleros

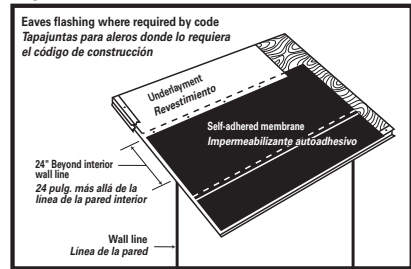

2 Underlayment:

Standard Slope (4" in 12" or more)

Application of underlayment, metal drip edges, and ice dam protection: See Fig. 2.

- (A) Apply one layer of underlayment over metal drip edge at eaves. Use only enough fasteners to hold in place.
- (B) Overlap successive courses 2". Overlap course ends 4". Side laps are to be staggered 6' apart.
- (C) Apply metal drip edge over underlayment at rake.

Fig. 2 Underlayment Standard Slope
Pendiente estándar del revestimiento

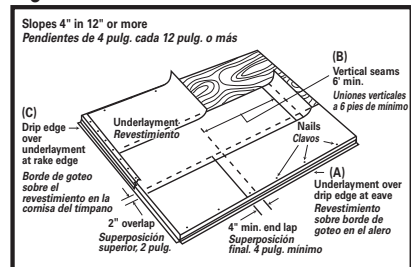

3 Underlayment:

Low Slope (2" in 12" to less than 4" in 12")

Application of underlayment, metal drip edges, and ice dam protection: See Fig. 3.

(A) Apply 19" starter strip of underlayment over metal drip edge at eaves. Use only enough fasteners to hold it in place.

(B) Use 36" strip of underlayment for remaining courses, overlapping each course 19". Side laps are to be staggered 6' apart.

(C) Apply metal drip edge over underlayment at rake.

Or WeatherLock® self-adhered underlayment or equivalent with a standard over lap of 3" and metal drip edge. See Fig. 3A.

Fig. 3 Underlayment Low Slope
Pendiente baja del revestimiento

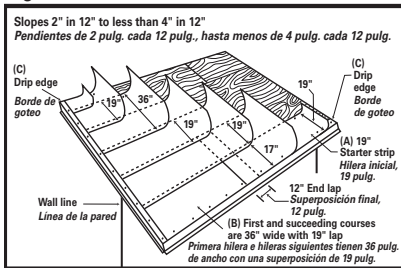
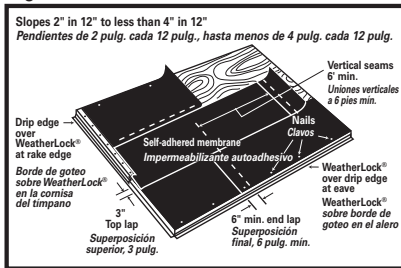

Fig. 3A Underlayment Low Slope
Pendiente baja del revestimiento



4 Shingle Fastening:

Place fasteners $6\frac{1}{8}$ " from bottom edge of each shingle and 1" from each end.

Standard Pattern Use four fasteners. See Fig. 4.

Six Nail Pattern Use six fasteners. See Fig. 4A.

Mansard or Steep Slope Fastening Pattern. Place fasteners $6\frac{1}{8}$ " from bottom edge to secure both layers of the shingle. See Fig. 4B.

Shingle Side View



REQUIRED: For slopes exceeding 60 degrees or 21 inches per foot, use six fasteners and four spots of asphalt roof cement per shingle. Apply immediately; one 1" diameter spot of asphalt roof cement under each shingle tab. Center asphalt roof cement 2" up from bottom edge of shingle tab. See Fig. 4B.

Roof Cement where required must meet ASTM D4586 Type I or II (Asbestos Free).

Six nail fastening pattern is required for maximum wind warranty. In addition, Owens Corning® Starter Shingles are required along the eave and rake. (See Starter Shingle instructions for details.)

Fig. 4 Standard Fastening Pattern
Esquema de instalación estándar

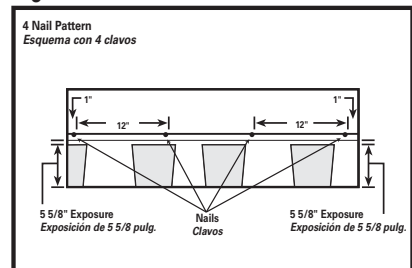

Fig. 4A Six Nail Fastening Pattern
Esquema de instalación con seis clavos

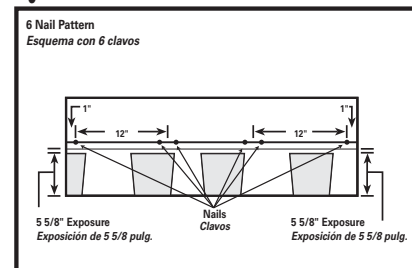
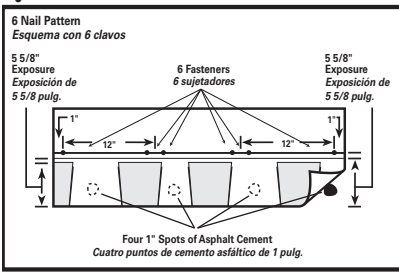

Fig. 4B Mansard or Steep Slope Fastening Pattern
Esquema de instalación en pendientes pronunciadas o mansardas



5 Shingle Application:

These shingles are applied with a 6 1/2" offset, with 5 5/8" exposure, over prepared roof deck, starting at the bottom of the roof and working across and up. This will blend shingles from one bundle into the next and minimize any normal shade variation. Application with offsets of 4" or 8" are also acceptable.

Caution must be exercised to assure that end joints are no closer than 2" from fastener in the shingle below and that side laps are no less than 4" in succeeding courses. Refer to course application steps for specific instructions.

Starter Course:

Use an Owens Corning® Starter shingle product or trim 5 5/8" from the starter course shingle. Trim 6 1/2" off the rake of the starter course shingle and flush with the drip edge along the rake and eaves edge, and continue across the roof. Use 5 fasteners for each shingle, placed 2" to 3" up from eaves edge. See Fig. 5. (If no drip edge is used, shingles must extend a minimum of 1/2" and no more than 1" from rake and eaves edge.)

Fig. 5 Shingle Application
Instalación de tejas

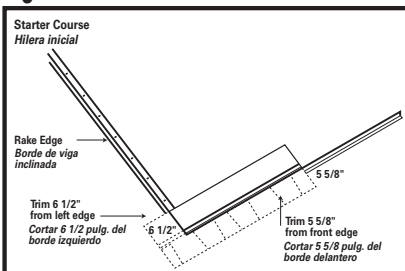

First Course:

Apply first course starting with the full shingle even with the starter course. See Fig. 5A. Fasten securely according to fastening instructions. See Fig. 4.

Second Course:

Remove 6 1/2" from the left end of this shingle and apply the remaining piece over and above the first course shingle and flush with edge of the first course with 5 5/8" exposure. See Fig. 5B. Fasten securely according to fastening instructions. See Fig. 4.

Fig. 5A Shingle Application
Instalación de tejas

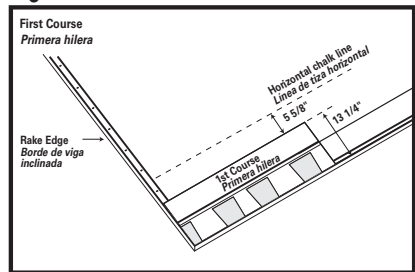

Fig. 5B Shingle Application
Instalación de tejas

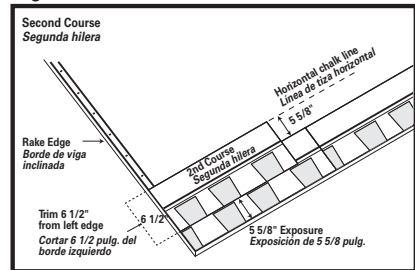
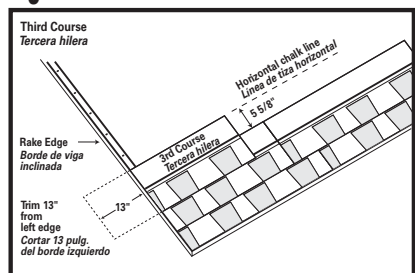

Fig. 5C Shingle Application
Instalación de tejas



Third Course:

Remove 13" from the left end of this shingle and apply the remaining piece over and above the second course shingle flush with edge of the second course with 5 $\frac{5}{8}$ " exposure. See Fig. 5C. Fasten securely according to fastening instructions. See Fig. 4.

Fig. 5D Shingle Application
Instalación de tejas

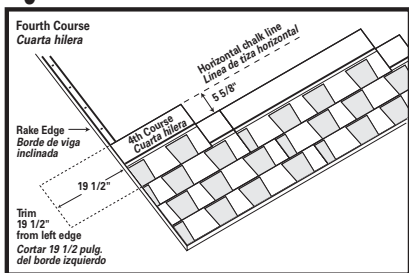

Fig. 5E Shingle Application
Instalación de tejas

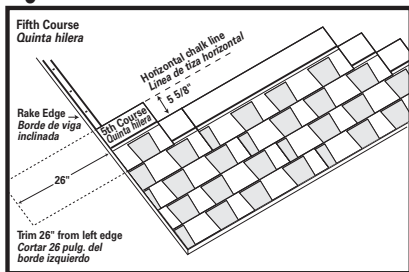
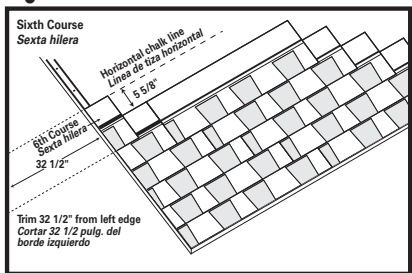

Fig. 5F Shingle Application
Instalación de tejas



Fourth Course:

Remove 19 $\frac{1}{2}$ " from the left end of this shingle and apply the remaining piece over and above the third course shingle and flush with edge of the third course with 5 $\frac{5}{8}$ " exposure. See Fig. 5D. Fasten securely according to fastening instructions. See Fig. 4.

Fig. 5G Shingle Application
Instalación de tejas

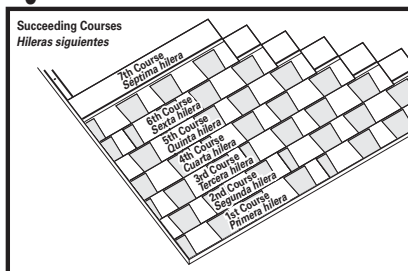

Fifth Course:

Remove 26" from the left end of this shingle and apply the remaining piece over and above the fourth course shingle and flush with edge of the fourth course with 5 $\frac{5}{8}$ " exposure. See Fig. 5E. Fasten securely according to fastening instructions. See Fig. 4.

Sixth Course:

Remove 32 $\frac{1}{2}$ " from the left end of this shingle and apply the remaining piece over and above the fifth course shingle and flush with edge of the fifth course with 5 $\frac{5}{8}$ " exposure. See Fig. 5F. Fasten securely according to fastening instructions. See Fig. 4.

Succeeding Courses:

For succeeding courses, repeat first through sixth course. See Fig. 5G.

6 Valley Construction:

Closed-Cut Valley See Fig. 6.

A closed-cut valley can be used as an alternative to woven and open valley and is applied as follows:

Lay a 36" wide valley liner of self-adhered membrane underlayment or equivalent. A 36" wide minimum 50 lb. smooth surface roll roofing can also be used as a valley liner. Lay all shingles on one side of valley and across center line of valley a minimum of 12". Fasten a minimum of 6" away from center line on each side of valley. Strike a chalk line 2" from the center line of the unshingled side. Apply shingles on the unshingled side up to the chalk line and trim, taking care not to cut the underlying shingles. Clip upper corners of these shingles, cement and fasten. Both woven and metal valleys are acceptable alternatives.

Fig. 6 Closed-Cut Valley Construction
Construcción del valle con corte cerrado

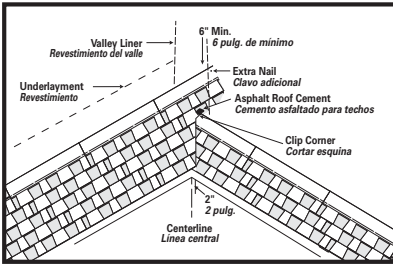

7 Step Flashing:

Use 10" long and 2" wider than expected exposure corrosion-resistant metal where roof planes butt against vertical sidewalls or chimneys. See Fig. 7.

Fig. 7 Step Flashing
Tapajuntas escalonado

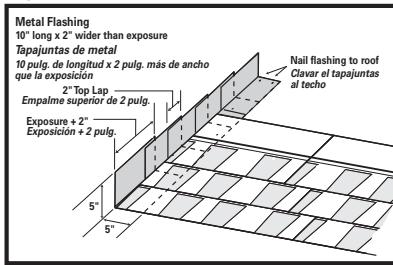

8 Hip & Ridge Application:

Use corresponding Owens Corning® Hip & Ridge shingles to best complement shingle color. Follow specific application instructions as printed on the Hip & Ridge shingle package. See Fig. 8.

Fig. 8 Hip & Ridge Application
Instalación de caballetes y cumbresras

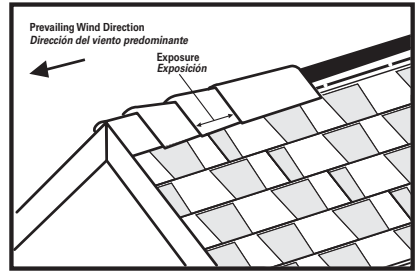

SUPREME® SHINGLES

Application Instructions

Before installing this product, check local building codes for their roofing requirements.

These shingles are designed for new or reroofing work over any properly built and supported wood roof deck having adequate nail holding capacity and a smooth surface. Check local building codes.

Precautionary Note:

The manufacturer will not be responsible for problems resulting from any deviation from the recommended application instructions and the following precautions:

Roof Top Loading: Lay shingle bundles flat. Do not bend over the ridge.

Roof Deck: • 6" Minimum roof deck boards
• Minimum 3/8" plywood • Minimum 7/16" OSB

Regardless of deck type used, the roofing installer must:

1. Install the deck material in strict compliance with the deck manufacturer's instructions.
2. Prevent the deck from getting wet before, during and after installation.

Ventilation: Must meet or exceed FHA Minimum Property Standards.

Handling: Use extra care in handling shingles when the temperature is below 40°F.

Storage: Store in a covered ventilated area at a maximum temperature of 110°F. Bundles should be stacked flat. Protect shingles from weather when stored at the job site. Do not store near steam pipes, radiators, etc.

Fastener requirement: Use galvanized steel, stainless steel, or aluminum nails minimum 12 gauge shank with 3/8" diameter head. Owens Corning Roofing recommends that fasteners comply with ASTM F1667. Check local building codes.

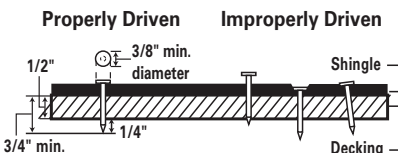

All Fasteners must penetrate at least 3/4" into the wood deck or completely through sheathing.

Notice: Owens Corning Roofing recommends the use of nails as the preferred method of attaching shingles to wood decking or other nailable surface.

1 Ice Dam Protection:

Use Owens Corning® Self-Adhered Ice & Water Barrier on the eaves in all regions of the county where roofs have had a history of ice and water backup.

WeatherLock® underlayment or equivalent eave and flashing membrane applied to a point at least 24" beyond interior wall line. See manufacturer's installation instructions. See Fig. 1.

Fig. 1 Specialty Eave Flashing
Solins spéciaux

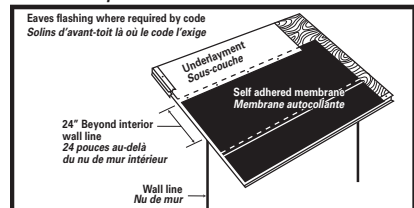

2 Underlayment:

Standard Slope (4" in 12" or more)

Application of underlayment, metal drip edges, and ice dam protection: See Fig. 2.

- (A) Apply one layer of underlayment over metal drip edge at eaves. Use only enough fasteners to hold in place.
- (B) Overlap successive courses 2". Overlap course ends 4". Side laps are to be staggered 6' apart.
- (C) Apply metal drip edge over underlayment at rake.

Low Slope (2" in 12" to less than 4" in 12") Application of underlayment, metal drip edges, and ice dam protection: See Fig. 2A.

- (A) Apply 19" starter strip of underlayment over metal drip edge

at eaves. Use only enough fasteners to hold it in place.

(B) Use 36" strip of underlayment for remaining courses, overlapping each course 19". Side laps are to be staggered 6' apart.

(C) Apply metal drip edge over underlayment at rake.

Or WeatherLock® self-adhered underlayment or equivalent with a standard over lap of 3 inches and metal drip edge. See Fig. 2B.

Fig. 2 Underlayment – Standard Slope
Sous-couche – pentes régulières

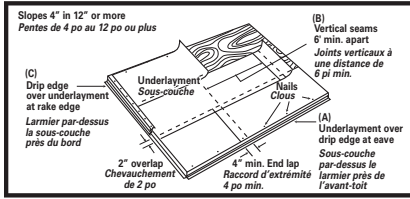

Fig. 2A Underlayment – Low Slope
Sous-couche sur faibles pentes

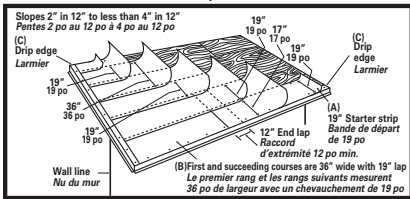
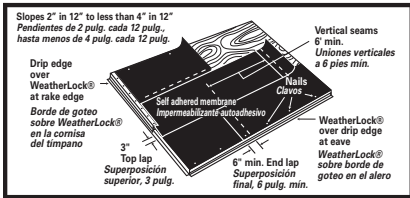

Fig. 2B Underlayment – Low Slope
Sous-couche sur faibles pentes



3 Shingle Fastening:

Place fasteners 5/8" above the tab cut-out and below the adhesive strip. Fastening into the sealant strip interferes with sealing and contributes to blow-offs.

Standard Pattern

Use four fasteners. See Fig. 3.

Fig. 3 Standard Pattern
Pose régulière

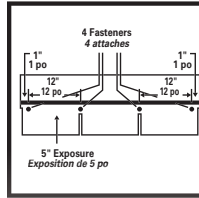
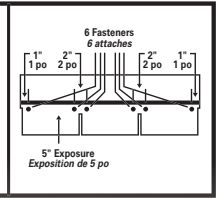

Fig. 3A Six Nail Pattern
Pose à six clous



Six Nail Pattern

Use six fasteners. See Fig. 3A.

Fig. 3B Mansard or Steep Slope Pattern
Toit en mansarde ou à forte pente

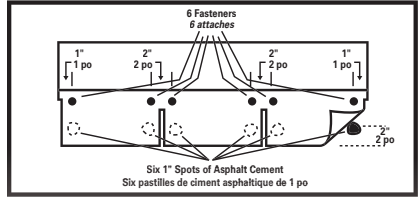

Mansard or Steep Slope Pattern

REQUIRED: For slopes exceeding 60 degrees or 21 inches per foot, use six fasteners and six (6) spots of asphalt roof cement per shingle. Apply immediately, one 1" diameter spot of asphalt roof cement under each corner shingle tab. Center asphalt roof cement 2" up from bottom edge of shingle tab. See Fig. 3B.

Roof Cement where required must meet ASTM D4586 Type I or II (Asbestos Free)

4

Offset Measurement:

Apply shingles over properly prepared roof deck, starting at bottom of roof and working across and up. This will blend shingles from one bundle into the next and minimizes any normal shade variation. Supreme AR shingles are applied with a 6" offset. While a 6" offset is recommended, application with offsets of 4" or 5" are also acceptable. Caution must be exercised to assure that end joints are no closer than 2" from a fastener in the shingle below and that side laps are no less than 4" in succeeding courses. Refer to course applications steps for specific instructions. If racking application methods are used, the applicator must ensure that the proper

number of fasteners is used, and use shingles from several different bundles to reduce potential for color variation. See Fig. 4.

Fig. 4 Offset Measurement
Distance de décalage

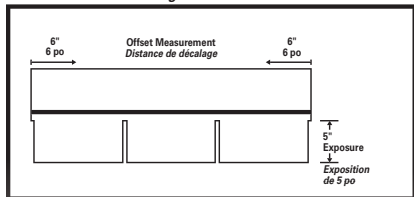

5 Shingle Application Starter Course See Fig. 5.

(A) Trim tabs off all starter course shingles so sealant can seal along the eave's edge. See Fig. 5.

Fig. 5 Shingle Application
Installation des bardeaux

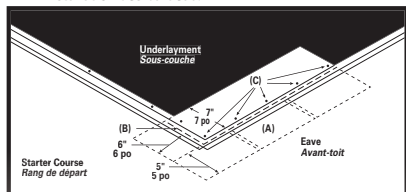

(B) Trim 6" off rake end of first shingle. Extend 3/8" beyond rake and eaves or flush with the drip edge, and fasten.

(C) Complete rest of starter course. Use 5 fasteners for each shingle, placed 2" - 3" up from the eaves edge.

First Course See Fig. 5A.

(D) Apply first course starting with a full shingle, even with the starter course. Fasten securely according to shingle fastening instructions above.

Note: Complete course with full shingles.

Second Course

(E) Begin second course by positioning first shingle 6" from the end of the underlying shingle, with the butt edge aligned with the top of the cutouts in the course below.

(F) Leave 5" exposure, fasten securely, and trim excess overhang at rake.

Note: Complete course with full shingles.

Third Course through Sixth Course

(G) Begin each subsequent course by positioning the first shingle 6" from the end of the underlying shingle, with the butt edge aligned with the top of the cutouts in the course below. Complete by repeating step (F).

Note: Complete each course with full shingles.

Seventh Course

(H) Apply seventh course starting with a full shingle. Leave 5" exposure and fasten securely. Complete by repeating step (F).

Note: Complete course with full shingles. For succeeding courses, repeat steps for second through seventh courses. See Fig. 5A.

Fig. 5A Shingle Application
Installation des bardeaux

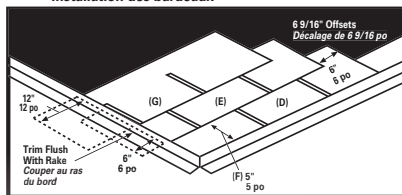

6 Valley Construction Closed-Cut Valley See Fig. 6.

A closed-cut valley can be used as an alternative to woven or open valley and is applied as follows: Lay a 36" wide valley liner of self adhered membrane underlayment or equivalent. A 36" wide minimum 50 lb. roll roofing can also be used as a valley liner. Lay all shingles on one side of valley and across center line of valley a minimum of 12". Fasten a minimum of 6" away from center line on each side of valley. Strike a chalk line 2" from the center line of the unshingled side. Apply shingles on the unshingled side up to the chalk line and trim, taking care not to cut the underlying shingles. Clip upper corners of these shingles, cement and fasten. Both woven and metal valleys are acceptable alternatives.

Fig. 6 Closed Cut Valley Construction
Construction d'une noue fermée

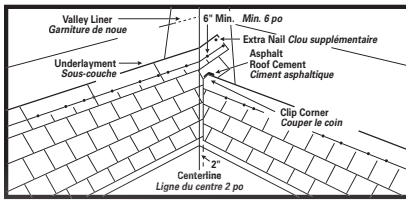

7 Step Flashing

Use 10" long and 2" wider than expected exposure corrosion-resistant metal where roof planes butt against vertical sidewalls or chimneys. See Fig. 7.

Fig. 7 Step Flashing
Solins en gradins

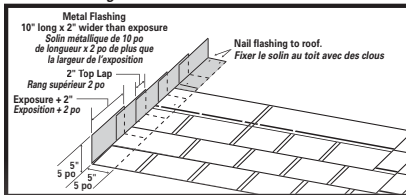

8 Hip and Ridge Application

Cut full Supreme AR shingles into three 12" x 12" hip and ridge shingles. Start hips at the eave and work up to ridge. Apply ridge only after hips have been applied, beginning on end of ridge opposite prevailing wind direction. Leave 5" exposure per shingle for hip and ridge application. Bend over the ridge; fasten on each side 6" from exposed end, 1" up from the edge. Cover exposed nails with asphalt cement. See Fig. 8.

Fig. 8 Hip & Ridge
Installation sur les arêtes et les faites

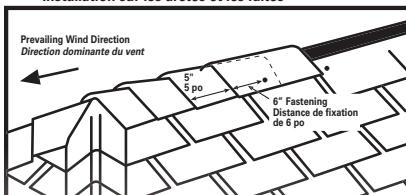

9 Reroofing with Shingles

If old asphalt shingles are to remain in place, nail down or cut away all loose, curled or lifted shingles. Sweep the surface clean of all loose debris just prior to applying the new

roofing. Ensure proper size and length of fasteners. If roofing over old wood shingles, cut back the old shingles at eaves and rakes and apply wood edging strips. Some local building codes may require the use of a No. 30 asphalt saturated felt over the old wood shingles prior to reroofing. Consult local building code authorities. Surface must be smooth before shingles are installed. Make deck smooth by nailing down all loose and curled shingles, protruding nails, etc. Install beveled wood feathering strips, if necessary.

When roofing over existing shingles with a 5" tab exposure, the following procedure should be used for smoothest finished appearance and ease of alignment:

(A) Starter Course

Make starter shingles by removing the 5" tabs and cutting a 2" strip off the top of the shingles. Lay starter shingles so the top edge butts against the lower edge of the second course of the existing roof. Place the thermal sealing adhesive toward the eave edge. Secure with five fasteners evenly spaced per starter shingle placed 2" to 3" from the eaves edge. Complete the course.

(B) First Course

Trim 3" off the tops of all first course shingles. Lay them with their top edge butted against the bottom of the third course of the existing roof. Continue as instructed above.

(C) Second Course and Others

Use full-sized shingles and place them so their top edge is butted against the bottom edge of the next course of existing shingles. Continue as instructed above.

Note: Refer to ARMA Technical Bulletin regarding reroofing at <http://www.asphaltroofing.org/>

2" & 4" SELVAGE MINERAL SURFACED ROLL ROOFING

Application Instructions for FIBERGLAS® Mineral Surfaced Roll Roofing

Not to be used as part of a Built-Up Roofing System. Apply over wood decks when incline is not less than 1" per foot. The deck must drain freely at all points.

General: It is suggested that roll roofing not be applied at temperatures below 50°F. When it is necessary to handle the material below this limit, it should be warmed before unrolling in order to avoid cracking.

The roll roofing should be cut into maximum 18' lengths and stacked in a pile on a smooth surface before application until they flatten out. This is important to prevent wrinkling after application.

Roof Deck: The roof deck shall be dry, firm, smooth, and constructed of a minimum $\frac{3}{8}$ " thick plywood, $\frac{7}{16}$ " oriented strand board (OSB) or dry well-seasoned lumber, nominal 1" thick, not over 6" in width. Boards shall be laid close together and securely nailed. If plywood or OSB is used it should be as recommended by the American Plywood Association, Underwriters Laboratories Inc.® or local building codes. Plywood and OSB sheathing must be spaced a minimum of $\frac{1}{8}$ " and maximum $\frac{1}{4}$ ".

Preparation of Roof Deck

New Construction: Install metal drip edges at eaves and rakes. Sweep roof deck clean of loose particles. Apply one layer of underlayment of #15 asphalt saturated felt over the entire roof surface. Lay in a horizontal manner lapping each course over the lower course 2"; and where ends join, lap them 4". Lay underlayment at least 6" over all hips, ridges and valleys.

Re-Roofing: Remove any slag or gravel. Cut open all blisters and buckles, and nail both edges to give a smooth surface; also nail edges of large cracks. Remove loose nails and drive into sound deck. Before beginning application of roofing, sweep roof deck clean of all loose particles and dirt.

Application

Nails: Use large head corrosion-resistant nails, 11- or 12-gauge, with heads at least $\frac{3}{8}$ " in diameter. Nails should be long

enough to penetrate into wood deck at least $\frac{3}{4}$ ", or completely through plywood deck or OSB a minimum of $\frac{1}{8}$ ".

Concealed Nail Method

Edge Strips: Place 9" wide strips of roll roofing along the eaves and rakes, positioning them to overhang the deck $\frac{1}{4}$ " to $\frac{3}{8}$ ". Fasten the strips with rows of nails located 1" and 8" from the roof edge and spaced 4" on center in each row.

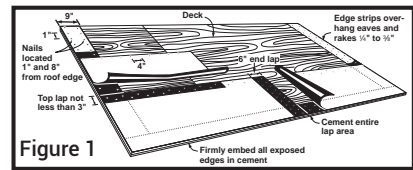

First Course: Apply the first course with a full-width strip of roll roofing so that its lower edge and ends are flush with the edge strips at the eaves and rakes. Fasten the upper edge with nails so that the next course will overlap them a minimum of 1". Lift the lower edge of the first course and cover the edge strips with lap cement. In cold weather, turn the course back carefully to avoid damaging the roofing material. Press the lower edge and rake ends of the first course firmly into the cement-covered edge strips. Work from one side of the sheet to the other to avoid wrinkling or bubbling.

End laps should be 6" wide and cemented over the full lap area with the recommended cement. Nail the underlying sheet in rows 1" and 5" from the end of the sheet with the nails spaced 4" on center and slightly staggered. End laps in succeeding courses must not line up with one another.

Second and Succeeding Courses: Apply the second course so that it overlaps the first course at least 3". Fasten the upper edge to the deck, cement the laps and finish installing the sheet in the same manner as the first course. Follow the same procedure for each successive course. Do not apply nails within 18" of the rake until cement has been applied to the edge strip and the overlying strip has been pressed down.

Hips and Ridges: Trim, butt and nail the sheets as they meet at a hip or ridge. Next, cut 12" x 36" strips from the roll roofing and bend them lengthwise to lay 6" on each side of the joint. Do not bend the strips in cold weather without first warming them. These will be used as "shingles" to cover the joint, each one overlapping the other by 6" as shown in Figure 2.

Start hips at the bottom and ridges at the end opposite the direction of the prevailing winds. To guide the installation, snap a chalk line 5½" from and parallel to the joint on both sides. Apply asphalt plastic cement evenly over the entire area between chalk lines from one side of the joint to the other. Fit the first folded strip over the joint and press it firmly into the cement, driving two nails 5½" from the edge of the end that will be lapped. Cover the 6" lap on this strip with lap cement. Then place the next strip over it. Nail and cement in the same manner as the first strip. Continue the same procedure until the hip or ridge is finished.

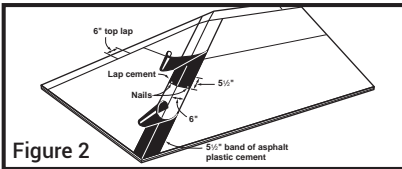

Figure 2

OWENS CORNING SHALL NOT BE RESPONSIBLE FOR ANY DAMAGE, LOSS, COST, EXPENSE OR LIABILITY RELATING TO FAILURE TO FOLLOW THESE INSTRUCTIONS. FAILURE TO FOLLOW THESE INSTALLATION INSTRUCTIONS MAY AFFECT OWENS CORNING OBLIGATIONS UNDER THIS PRODUCT'S LIMITED WARRANTY.

Applicable Standards

ASTM E 108, Class C UL 790, Class C

Owens Corning warrants that this product meets our specifications and is free from manufacturing defects when manufactured. Owens Corning shall have no liability for any product failures or damage caused by improper installation or any other cause other than manufacturing defects. Should the product prove to be other than as warranted, Owens Corning's sole and exclusive liability shall be limited, at the option of Owens Corning, to either replacement of the product or providing customer with a full refund of the original cost of the product.

THE FOREGOING CONSTITUTES OUR EXCLUSIVE WARRANTY, AND WE HEREBY DISCLAIM ALL OTHER WARRANTIES, WHETHER EXPRESSED OR IMPLIED, INCLUDING THE IMPLIED WARRANTIES OF MERCHANTABILITY AND FITNESS FOR A PARTICULAR PURPOSE. IN NO EVENT SHALL OWENS CORNING BE LIABLE TO CUSTOMER FOR INCIDENTAL, INDIRECT OR CONSEQUENTIAL DAMAGES.

DECKSEAL SELF-ADHERED ROOFING SYSTEM COMPONENTS FOR RESIDENTIAL SLOPE

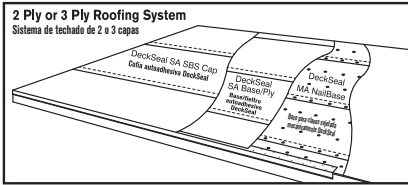

NOTE: If installing the DeckSeal MA NailBase under the DeckSeal SA SBS Cap see the following instructions for each of those components.

Owens Corning® DeckSeal MA NailBase

This product is to be used under Owens Corning® DeckSeal SA SBS Cap and should not be left exposed.

Do not use DeckSeal MA NailBase in a torch down application.

Storage

Owens Corning® DeckSeal MA NailBase should be stored at room temperature whenever possible. Do not store at temperatures above 90°F (32°C).

Precautionary Notes

Owens Corning Roofing recommends strict adherence to OSHA safety regulations.

DeckSeal MA NailBase is designed to be installed on roof slopes between ¼:12 and 2:12 and is to be applied directly to an exterior grade of Plywood or OSB. Plywood must be minimum 15/32 inch and OSB minimum 7/16 inch. Check local codes.

Owens Corning® DeckSeal SA SBS Cap is to be applied directly to Owens Corning® DeckSeal MA NailBase or DeckSeal SA Base/Ply.

- Apply only when the weather is dry and the ambient temperature is 45°F (7°C) and rising. Do not install when water in any form (i.e. rain, dew, ice, frost, snow) exists. All roof deck application areas must have positive drainage, continuous support, and be structurally sound to support the dead load requirements of the roofing system.

- Apply only over clean, dry, dust-free surfaces.
- Ensure installation of DeckSeal MA NailBase does not prevent or interfere with ventilation of the existing structure.

Failure to follow manufacturer's application instructions may void product warranty.

Plan the job so that the DeckSeal MA NailBase is covered by the DeckSeal SA SBS Cap the same day.

Application

Step 1. Sweep the roof surface to remove any dust, dirt, or debris prior to starting installation.

Step 2. Cut the DeckSeal MA NailBase to manageable lengths. Allow the cut sheets to relax prior to installation. Failure to allow the sheets to relax may result in wrinkles in the finished surface.

Step 3. Initiate starter course:

- For a 2 ply (layer) system the starter course will always be ½ of the roll width.
- For a 3 ply (layer) system the starter course will always be a of the roll width (approximately 12 inches) and cut from the DeckSeal MA NailBase roll. (Cutting on one of the 12" lines is approximately of the roll width).

The side lap seams of any 2 or 3 ply system layer should always be offset from the other layers.

Step 4. Lay the material flat on the roof aligned with the eaves or at the lowest point of the roof.

Step 5. Nail the starter course at 6 inches on center across the center of the sheet using 1 inch diameter metal cap nails. See Fig. 1

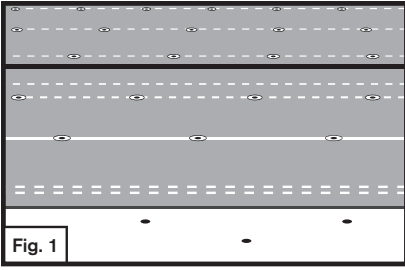

Do not nail along the edges at this time (edge metal will be added later), only in the center. If additional pieces are needed to complete the starter course, continue to install each piece overlapping the preceding piece by 6 inches. Nail in the middle of the 6 inch end lap at 6 inches on center.

Step 6. When the eaves starter sections are completed, position the next course (and all subsequent courses) by overlapping the previous course by 3 or 4 inches. Install metal cap nails at 6 inches on center in the 3 or 4 inch side lap.

All additional courses will require 2 rows of nails at 6 inches on center, evenly spaced vertically, and staggered down the center of the sheet. All end laps should be overlapped a minimum 6 inches. See Fig. 1

When installing each course stagger the end laps by 36 inches between courses.

Edge Metal Install

For 2 ply systems, the edge metal is installed directly over the base sheet. For a 3 ply system, the edge metal is installed over the second ply (layer).

1. The edge metal must be minimum 24 gauge galvanized steel or 0.040 inch formed aluminum, primed with either an asphaltic primer that meets ASTM D41 or a commercially available water-based acrylic primer.
2. The roof flange of the edge metal should be 3 or 4 inches wide.
3. Primed edge metal must be dry to the touch before membrane application.
4. Install the roof flange of the edge metal over the base sheet at the lowest point on the roof. Nail the edge metal 4 inches on center in a staggered pattern. See Fig. 1
5. Install a minimum 8 inch wide strip of self-adhered DeckSeal SA Base/Ply over the edge metal leaving 1/2 inch of edge metal exposed at the eaves.

NOTE: If installing the DeckSeal SA Base/Ply under DeckSeal SA SBS Cap, see the DeckSeal SA Base/Ply box for instructions for that component.

Owens Corning® DeckSeal SA Base/Ply

This product is to be used under Owens Corning® DeckSeal SA SBS Cap

Do not use Owens Corning® DeckSeal SA Base/Ply in a torch down application.

Storage

Owens Corning® DeckSeal SA Base/Ply self-adhered membrane should be stored at room temperature whenever possible. Do not store out of the box for prolonged periods, or in temperatures above 90°F (32°C). Do not remove the roll from the box until it is to be installed.

Precautionary Notes

Owens Corning Roofing recommends adherence to OSHA safety regulations.

DeckSeal SA Base/Ply is designed to be installed on roof slopes between 1/4:12 and 2:12 and is to be applied directly to an exterior grade of Plywood or OSB when used as a base sheet in a 2 ply system, or Owens Corning® DeckSeal MA NailBase when used as the second ply in a 3 ply system.

Note: When installing DeckSeal SA Base/Ply, existing Plywood and/or OSB must be primed with either an asphaltic primer that meets ASTM D41 or a commercially available water-based acrylic primer. New plywood and DeckSeal MA NailBase do not need to be primed.

Note: Any primed substrate must be fully dry prior to installation. Refer to manufacturer's recommendations. Plywood must be minimum 15/32 inch and OSB minimum 7/16 inch. Check local codes.

- Apply only when the weather is dry and the ambient temperature is 45°F (7°C) and rising. Do not install when water in any form (i.e. rain, dew, ice, frost, snow) exists. All roof deck application areas must have positive drainage, continuous support, and be structurally sound to support the dead load requirements of the roofing system.
- Apply only over clean, dry, dust-free surfaces.

- Ensure installation of DeckSeal SA Base/Ply does not prevent or interfere with ventilation of the existing structure.

Failure to follow manufacturer's application instructions may void product warranty.

Plan the job so that the DeckSeal SA Base/Ply is covered by the DeckSeal SA SBS Cap the same day.

Application

Step 1. Sweep the roof surface to remove any dust, dirt, or debris prior to starting installation.

Step 2. Cut the DeckSeal SA Base/Ply to manageable lengths. Allow the cut sheets to relax prior to installation. Failure to allow the sheets to relax may result in wrinkles in the finished surface.

Step 3. Initiate starter course:

- For a 2 ply (layer) system the starter course will always be 1/2 of the roll width.
- For a 3 ply (layer) system the starter course will always be 1/3 of the roll width. (Cutting on one of the 12" lay lines will leave approximately 1/3 of the roll width.) If using SA Base/Ply as a second layer of a 3 ply system, the starter course for that layer will be 2/3 of the roll width.

The side lap seams of any 2 or 3 ply system layer should always be offset from the other layers.

Step 4. There are several ways to remove the release liner from the DeckSeal SA Base/Ply. One method is as follows: Lay the material flat on the roof aligned with the eaves edge at the lowest point on the roof.

Step 5. Fold the aligned sheet back half way exposing the release liner. See Fig. 1

Step 6. Peel release film at a 45° angle in a constant motion, while firmly holding the half of the sheet that is in contact with the roof in place as the liner is removed. See Fig. 1

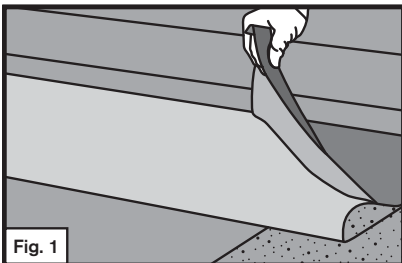

Fig. 1

Step 7. Use hand or foot pressure to bond that portion of the sheet to the deck.

If the split release liner remains on the opposite half of the sheet, flip the opposite half back and remove the remaining release liner. Use hand or foot pressure to bond that portion of the sheet to the deck. See Fig. 2

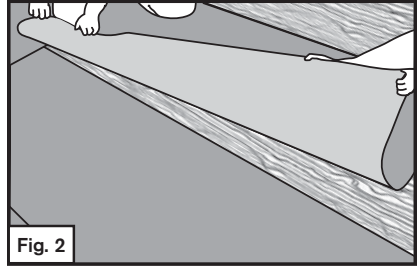

Fig. 2

Step 8. If additional pieces are needed to complete the starter course, the end lap to be overlapped must be cut at 45° angles on the top and bottom corners. See Fig. 3

The top corner on the piece that is overlapping the previous piece must also be cut on the top corner at a 45° angle. See Fig. 3

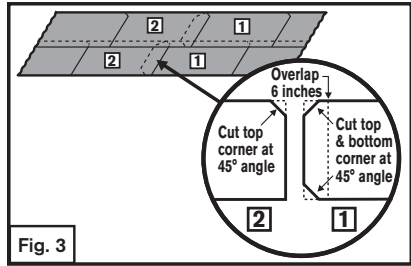

Fig. 3

The overlap is to be 6 inches. Remove the release liner and adhere as with the previous sheet.

Step 9. Roll side laps and end laps firmly with a hand roller to ensure full adhesion. See Fig. 4

If necessary, hot air weld or apply modified asphalt flashing cement at 45° cuts or at end lap seams.

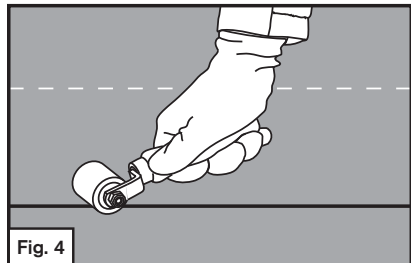
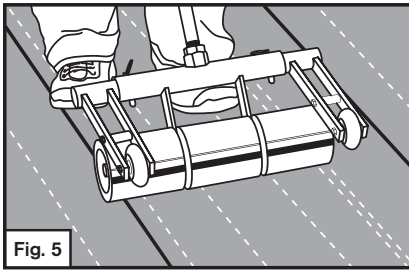

Fig. 4

Step 10. As each course is completed, roll the course with an 80 pound linoleum roller. Start at the center and work outward to remove trapped air. See Fig. 5



Step 11. When the eaves edge sections are completed, position the next course by overlapping the starter course by 3 to 4 inches.

When installing each subsequent course stagger the end laps by 36 inches between courses.

Step 12. One method to remove the release liner from a full sheet of DeckSeal SA Base/Ply is as follows:

- Position the sheet on the 3 or 4 inch overlap lay line and roll the bottom of the sheet half way back to expose the split release liner.
- Peel release film at a 45° angle in a constant motion, while firmly holding the half of the sheet that is in contact with the roof in place as the liner is removed.
- When the release film has been removed, carefully roll the sheet back down and press into place.
- Roll the opposite half of the sheet back and remove the release liner using the same method as in step "b".
- Roll the sheet back down and press firmly into place.

Step 13. If additional pieces are needed to complete the course, the end lap corners are to be cut at a 45° angle as was done in Step 9. The overlaps are to be 6 inches.

Step 14. When the SA Base/Ply courses are complete roll the entire surface with an 80 pound linoleum roller.

Edge Metal Install

For 2 ply systems, the edge metal is installed directly over the base sheet. For a 3 ply system, the edge metal is installed over the second ply (layer).

- The edge metal must be a minimum 24 gauge galvanized steel or 0.040 inch formed aluminum, primed with either an asphaltic primer that meets ASTM D41 or a commercially available water-based acrylic primer.
- The roof flange of the edge metal should be 3 or 4 inches wide.
- Primed edge metal must be dry to the touch before membrane application.
- Install the roof flange of the edge metal over the base sheet at the lowest point on the roof. Nail the edge metal 4 inches on center in a staggered pattern. See Fig. 2
- Install a minimum 8 inch wide strip of self-adhered DeckSeal SA Base/Ply over the edge metal leaving 1/2 inch of edge metal exposed at the eaves.

Owens Corning® DeckSeal SA SBS Cap

This product is not to be used in a torch down application.

Owens Corning® DeckSeal Low Slope products should be installed by a professional roofing contractor.

Storage

Owens Corning® DeckSeal SA SBS Cap should be stored at room temperature whenever possible. Do not store out of the box for prolonged periods, or in temperatures above 90°F (32°C). Do not remove the roll from the box until it is to be installed.

Precautionary Notes

Owens Corning Roofing recommends adherence to OSHA safety regulations.

DeckSeal SA SBS Cap is designed to be installed on roof slopes between 1/4:12 and 2:12 and is to be applied to an exterior grade of Plywood or OSB. Plywood must be minimum 15/32 inch and OSB must be minimum 7/16 inch. DeckSeal SA SBS Cap is to be applied directly to Owens Corning® DeckSeal MA NailBase or DeckSeal SA Base/Ply.

- Apply only when the weather is dry and the ambient temperature is 45°F (7°C) and rising. Do not install when water in any form (i.e. rain, dew, ice, frost, snow) exists.

- All roof deck application areas must have positive drainage, continuous support, and be structurally sound to support the dead load requirements of the roofing system.
- Apply only over clean, dry, dust-free surfaces.
- Ensure installation of DeckSeal SA SBS Cap does not prevent or interfere with ventilation of the existing structure.

Failure to follow manufacturer's application instructions may void product warranty.

Application:

Step 1. Sweep the roof surface to remove any dust, dirt, or debris prior to starting installation.

Step 2. Cut the DeckSeal SA SBS Cap to manageable lengths. Allow the cut sheets to relax prior to installation. Failure to allow the sheets to relax may result in wrinkles in the finished surface.

Step 3. The DeckSeal SA SBS Cap has a release film covering the selvage edge. The cap sheet should be installed with the selvage edge away from the eaves edge. The DeckSeal SA SBS Cap starter course is always installed full width.

Step 4. Lay the material flat on the roof aligned with the eaves edge at the lowest point on the roof.

One method to remove the release liner from the sheet of DeckSeal SA SBS Cap is as follows:

Step 5. Fold the aligned sheet back half way, exposing the split release liner. See Fig. 1

Step 6. Remove release liner at a 45° angle in a constant motion, while firmly holding the half of the sheet that is in contact with the roof in place as the liner is removed. See Fig. 1

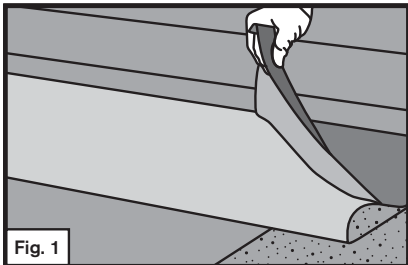

Fig. 1

Now that the release liner is removed, roll the sheet and press firmly into place.

Now roll the opposite half of the sheet back and remove the release liner using the same method as above.

If additional pieces are needed to complete the starter course, the end lap to be overlapped must be cut at 45° angles on the top and bottom corners. See Fig. 2

The top corner on the piece that is overlapping the previous piece must also be cut on the top corner at a 45° angle. See Fig. 2

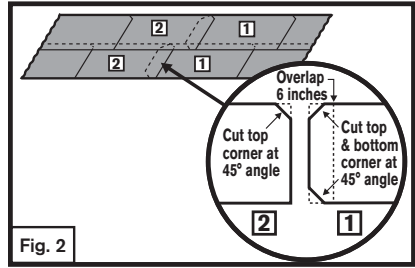

Fig. 2

The overlap is to be 6 inches. Remove the release liner and adhere as with the previous sheet.

Remove the side lap selvage edge release film on the area to be overlapped.

Do not remove the remaining release film covering the side lap selvage edge at this time.

Step 7. The end of each roll of DeckSeal SA SBS Cap has a factory end lap selvage edge covered with a release film. Remove the end lap release film and press the overlapping sheet into place. See Fig. 3

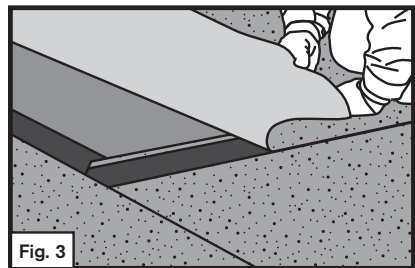

Fig. 3

If necessary, during cool weather, hot air weld or apply modified asphalt flashing cement at all 45° cuts or at end lap seams and T-joints.

Where there is no factory selvage edge for end laps, the following methods can be used.

HOT AIR WELDING

The area between the granular surface and self-adhesive backing can be heated with a hot air welding tool and rolled with a hand

roller. This will ensure a water tight seal to the end laps. See Fig. 4

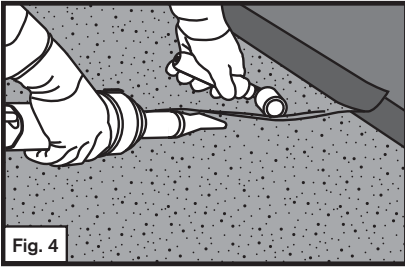

MODIFIED ROOF CEMENT

In lieu of hot air welding, the top layer can be set in a thin layer of modified asphalt flashing cement that is at least 6 inches wide and approximately 1/8 inch thick. Take care to prevent roof cement from oozing onto exposed area. If this should occur, sprinkle loose granules on the exposed asphalt immediately. See Fig. 5

End laps must be a 6 inch minimum and fully adhered.

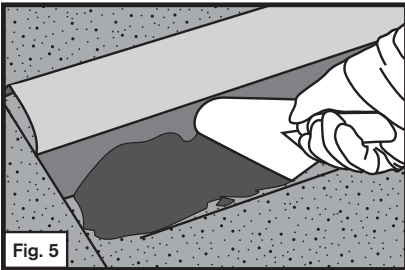

Step 8. Press each sheet into place with firm, even pressure.

Step 9. Roll edges and all lap seams firmly with a hand roller to ensure full adhesion. After each course is completed roll the course with an 80 pound linoleum roller. Start at the center and work outward to remove trapped air.

Step 10. For the succeeding course, position the next sheet by completely overlapping the salvage edge of the previous sheet. See Fig. 6

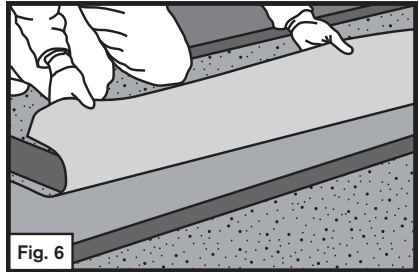

Be sure to offset end laps on each subsequent course a minimum of 36 inches.

Only remove enough of the salvage edge release film on the preceding roll to complete each section of the install. Removing more film than is necessary may cause the exposed adhesive to stick to the release liner of subsequent sheets during alignment. See Fig. 7

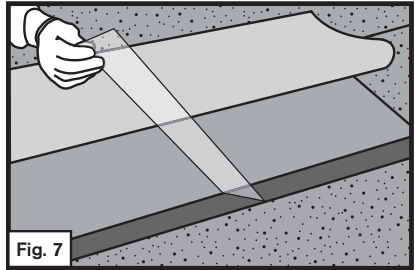

Remove release liner on succeeding course as previously described.

Step 11. After adhering rolls, it is required that uniform pressure be applied to the entire deck area using a 80 pound linoleum roller. Care must be taken to prevent injury when rolling, especially on sloped surfaces.

WEATHERLOCK® MAT SELF-SEALING ICE & WATER BARRIER

For sloped residential buildings with wood decks

WeatherLock® Self-Sealing Ice & Water Barrier installed between the roof deck and asphalt shingles, wood shakes, or slate roof assemblies helps to lock out damage from wind-driven rain and ice damming. This exclusive Owens Corning Roofing composition is engineered to lay flat and remain dimensionally stable. Rain. Shine. Or ice.

WeatherLock Ice & Water Barrier helps prevent costly damage from ice and water seeping through the roof and roof deck, such as:

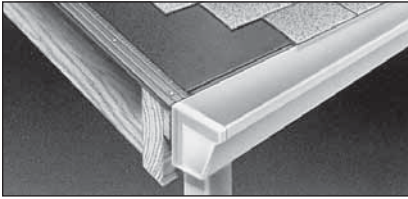

Ice Damming

Continual thawing and refreezing of melting snow or the backup of frozen slush in gutters can cause water leakage.

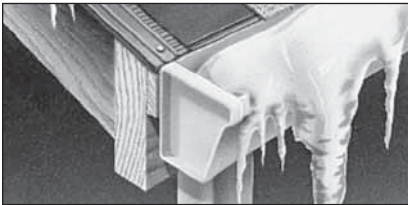

Wind-Driven Rain

Hard, wind-driven rain can cause backup in gutters and drains.

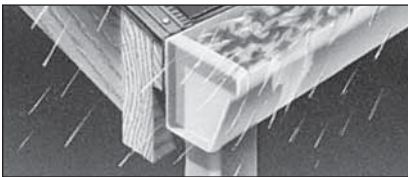

Caution

Read and understand all instructions and precautions before applying *WeatherLock Ice & Water Barrier*.

Deck Preparation

1. Owens Corning® *WeatherLock G, Flex, Mat and Cold Climate* should be applied on roofs having slopes of 2" rise minimum in 12" run or greater.
2. It can be applied on new construction or when re-roofing, provided existing shingles have been removed. Remove all old roofing down to the deck, or in new construction, apply over the new deck.
3. Sweep the deck surface to remove dirt and debris. The deck must be clean and dry before applying *WeatherLock* products. Replace any damaged or rotted deck boards. No primer is necessary.

Eave Preparation

4. *WeatherLock* products should be applied over the metal drip edge at the eave; ensure metal drip edge is nailed properly.
5. *WeatherLock* products should be applied under the drip edge at the rake.

Installation

6. Unroll *WeatherLock* underlayment and cut into 10'–20' lengths, depending on length of job. Allow to relax for 3–5 minutes before installing.
7. Reroll each portion. Remove the first two feet of the release backer and press the product into place. While supporting the roll with one hand, remove the release backer with the other hand and press or roll into place. *WeatherLock* products may be secured with nails (18" on center) on steeper slopes or as needed.
8. Along a valley, *WeatherLock* underlayment can be installed in valley as a valley liner. For maximum protection, the roll width should remain intact and extend 18" on either side of the valley. Peel back the poly backer sheet and press *WeatherLock* underlayment into place working from the center of the valley or ridge outward in each direction. Always apply valleys starting at the low point and work upwards. If an overlap is needed, be sure to overlap the previous piece by

3" *WeatherLock* products should be applied in valleys before doing eave applications with membranes.

9. *WeatherLock* products should extend from the eaves to a point 24" inside the exterior wall. This will place the *WeatherLock* products well above the maximum ice dam buildup line in most areas. Consult local building code for specific requirements.
10. If a second course is needed, overlap the second course onto the first course, 3" to the marked ply line. The lap area must be firmly hand rolled to ensure a watertight bond. Continue this same application procedure for additional courses, as needed. Adhesive is not required.
 - 10a. If installing *WeatherLock G* underlayment: If a second course is needed, overlap the second course 3" onto the top of the first course taped selvedge edge. The lap area must be firmly hand rolled to ensure a watertight bond.
11. Extra courses should be installed using the same application instructions as described in sections 1 and 2. Extra courses may be installed with nails (18" on center) as needed and depending on the slope of the roof. Use hand pressure or a roller to smooth the lapped area to insure good adhesion.
12. Overlap at least 6" when the ends of two rolls meet.
13. Cover *WeatherLock* product with finish roofing material. Do not allow *WeatherLock* underlayment to remain uncovered more than 30 days. Prolonged exposure to wind, sun and weather will adversely affect this product's installation and performance.

Precautions

1. *WeatherLock* products should be installed by a professional roofing contractor. *WeatherLock* underlayment is designed to be covered by asphalt shingles, wood shakes or quarry slate roof assemblies. Protection from sunlight is required to assure its long-term performance.
2. *WeatherLock* underlayment is a moisture and vapor barrier. Since ice buildup is partially a function of ventilation, the spaces under the covered deck area and the attic space must be ventilated in accordance with

FHA Minimum Property Standards and local building codes.

3. *WeatherLock* underlayment is intended for exterior application only.
4. Apply *WeatherLock* product directly to the wood deck. Do not apply shingle underlayment beneath *WeatherLock* product.
5. Shingles should not be installed over wrinkled or buckled *WeatherLock* product.
6. Use extreme caution when installing *WeatherLock* products. The *WeatherLock* underlayment surface is slippery even when dry. Use of fall protection is highly recommended. Consult OSHA for guidelines on fall protection (20 CFR 1926.500).
7. For best results, apply *WeatherLock* underlayment when the air temperature is over 40°F (5°C) but below 100°F (38°C). When temperatures are under 40°F, *WeatherLock* underlayment will not fully adhere until warmer temperatures. Store at room temperatures prior to installing product in cold weather. If applied in temperatures above 100°F (38°C), it may become difficult to remove the release poly backing. If this situation should occur, move product into a shaded area until the *WeatherLock* product is cool. Once cooled, the release poly backing can be easily removed.
8. Store *WeatherLock* product in a dry, well-ventilated area. Stand *WeatherLock* product upright. Do not store at 90°F (32°C) or warmer for extended periods of time. When applying *WeatherLock* product, always follow local building codes and the shingle manufacturer's instructions for installation of its product.

WEATHERLOCK® FLEX FLEXIBLE SELF-SEALING ICE & WATER BARRIER

For sloped residential buildings with wood decks

WeatherLock® underlayment installed between the roof deck and asphalt shingles, cedar shakes, concrete tile or slate roofing helps to lock out damage from wind-driven rain and ice damming. This exclusive Owens Corning composition of polyethylene, styrene-butadiene-styrene modified asphalt and a Fiberglas® mat for added reinforcement means *WeatherLock* underlayment can lie flat and remain dimensionally stable. Rain. Shine. Or ice.

WeatherLock underlayment helps to prevent costly damage from ice and water seeping through the roof and roof deck.

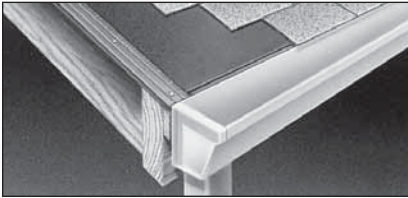

Ice Damming

Continual thawing and refreezing of melting snow or the backup of frozen slush in gutters can cause water leakage.



Wind-Driven Rain

Hard, wind-driven rain can cause backup in gutters and drains.

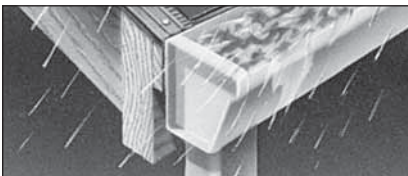

Caution

Read and understand all instructions and precautions before applying *WeatherLock Flex Flexible Self-Sealing Ice & Water Barrier*.

Deck Preparation

1. Owens Corning® *WeatherLock Flex Flexible Self-Sealing Ice & Water Barrier* should be applied on roofs having slopes of 1" rise in 12" run or greater.

It can be applied on new construction or when reroofing, provided existing shingles have been removed. Remove all old roofing down to the deck, or, in new construction, apply over the new deck.

Sweep the deck surface to remove dirt and debris. The deck must be clean, smooth and dry before applying *WeatherLock Flex*. Replace any damaged or rotted deck boards. No primer is necessary.

WeatherLock Flex is ideal for use around skylights, valleys and other roof penetrations.

Eave Preparation

2. *WeatherLock Flex* should be applied over the metal drip edge at the eave. *WeatherLock Flex* should be applied under the drip edge at the rake.

Installation

3. Unroll *WeatherLock Flex* and cut into manageable lengths, depending on length of job. Allow it to relax for 3 to 5 minutes.
4. Reroll each portion. Remove the first 2' of the release backer and press the product into place. Overlap the bottom edge (eave) by ¼".

While supporting the roll with one hand, remove the release backer with the other hand and press or roll into place. *WeatherLock Flex* may be secured with nails (18" on center) on steeper slopes or as needed.

5. Along a valley, *WeatherLock Flex* can be cut lengthwise for easier handling. For maximum protection, the roll width

should remain intact and extend 18" on either side of the valley. Peel back the backer sheet and press *WeatherLock Flex* into place working from the center of the valley or ridge outward in each direction. Always apply valleys starting at the low point and work upwards. *WeatherLock Flex* should be applied in valleys before doing eave applications with membrane.

6. *WeatherLock Flex* should extend from eaves to a point 24" inside the exterior wall. This will place the *WeatherLock Flex* well above the maximum ice dam buildup line, in most areas. Consult local building code for specific requirements.
7. If a second course is needed, overlap the second course onto the first course, to a minimum of 3". Continue this same application procedure for additional courses, as needed. Adhesive is not required.
8. Extra courses should be installed using the same application instructions as described in sections 3 and 4. Extra courses may also be installed with nails (18" on center) as needed and depending on the slope of the roof. Use hand pressure or a roller to smooth the lapped area to insure good adhesion.
9. Overlap at least 6" when the ends of two rolls meet.
10. Cover *WeatherLock Flex* with finish roofing material. Do not allow *WeatherLock Flex* to remain uncovered. Prolonged exposure to sun and weather will adversely affect this product's performance.

Precautions

1. *WeatherLock Flex* should be installed by a professional roofing contractor.
2. *WeatherLock Flex* is designed to be covered by shingles or other roofing material. Protection from sunlight is required to assure its long-term performance.
3. *WeatherLock Flex* is a moisture and vapor barrier. Since ice buildup is partially a function of ventilation, the spaces under the covered deck area and the attic space must be ventilated in accordance with FHA Minimum Property Standards and local building codes.
4. *WeatherLock Flex* is intended for exterior application only.
5. Apply *WeatherLock Flex* directly to the wood deck. Do not apply shingle underlayment beneath *WeatherLock Flex*.
6. Do not remove the cross-laminated polyethylene facer on surface of *WeatherLock Flex* product.
7. Use extreme caution when installing *WeatherLock Flex*. The *WeatherLock* surface is slippery even when dry. Use of Fall Protection is highly recommended. Consult OSHA for guidelines on Fall Protection (29 CFR 1926.500).
8. For best results, apply *WeatherLock Flex* when the air temperature is over 40°F (5°C) but below 100°F (38°C). If applied in temperatures below 40°F (5°C), *WeatherLock Flex* is stiffer and will not fully seal until it is warmed. If applied in temperatures above 100°F (38°C), it may become difficult to remove the release paper backing. If this situation should occur, move product into a shaded area until cool. Once cooled, the release paper backing can be easily removed.
9. Store *WeatherLock Flex* in a dry, well-ventilated area. Stand *WeatherLock Flex* upright. Do not store at 90°F (32°C) or warmer for extended periods of time.
10. When applying *WeatherLock Flex*, always follow local building codes and the shingle manufacturer's instructions for installation of its product.

WEATHERLOCK® G GRANULATED SELF-SEALING ICE & WATER BARRIER

For sloped residential buildings with wood decks

WeatherLock® underlayment installed between the roof deck and asphalt shingles, cedar shakes, concrete tile or slate roofing helps to lock out damage from wind-driven rain and ice damming. This exclusive Owens Corning composition of polyethylene, styrene-butadiene-styrene modified asphalt and a Fiberglas® mat for added reinforcement means *WeatherLock* underlayment can lie flat and remain dimensionally stable. Rain. Shine. Or ice.

WeatherLock underlayment helps to prevent costly damage from ice and water seeping through the roof and roof deck.

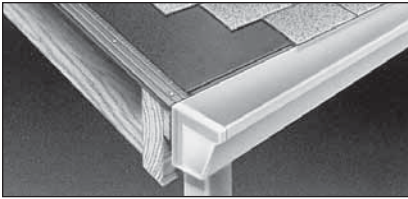

Ice Damming

Continual thawing and refreezing of melting snow or the backup of frozen slush in gutters can cause water leakage.

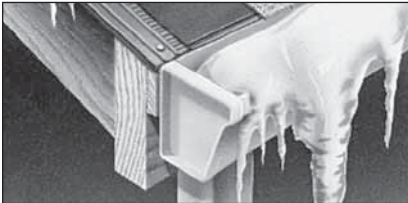

Wind-Driven Rain

Hard, wind-driven rain can cause backup in gutters and drains.

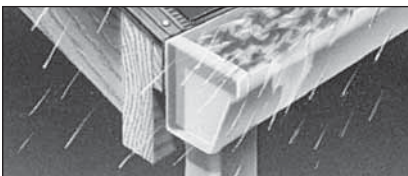

Caution

Read and understand all instructions and precautions before applying *WeatherLock G Granulated Self-Sealing Ice & Water Barrier*.

Deck Preparation

1. Owens Corning® *WeatherLock G Granulated Self-Sealing Ice & Water Barrier* should be applied on roofs having slopes of 1" rise in 12" run or greater.

It can be applied on new construction or when reroofing, provided existing shingles have been removed. Remove all old roofing down to the deck, or, in new construction, apply over the new deck.

Sweep the deck surface to remove dirt and debris. The deck must be clean, smooth and dry before applying *WeatherLock G Self-Sealing Ice & Water Barrier*. Replace any damaged or rotted deck boards. No primer is necessary.

Eave Preparation

2. *WeatherLock G* should be applied over the metal drip edge at the eave; ensure metal drip edge is nailed properly. *WeatherLock G* should be applied under the drip edge at the rake.

Installation

3. Unroll *WeatherLock G* and cut into 10' to 20' lengths, depending on length of job. Allow it to relax for 3 to 5 minutes.
4. Reroll each portion. Remove the first 2' of the release backer and press the product into place. Overlap the bottom edge (eave) by ¼".

While supporting the roll with one hand, remove the release backer with the other hand and press or roll into place. *WeatherLock G* may be secured with nails (18" on center) on steeper slopes or as needed.

5. Along a valley, *WeatherLock G* can be cut lengthwise for easier handling. For maximum protection, the roll width should remain intact and extend 18" on either side of the valley. Peel back the poly backer sheet and press

WeatherLock G into place working from the center of the valley or ridge outward in each direction. Always apply valleys starting at the low point and work upwards. *WeatherLock G* should be applied in valleys before doing eave applications with membrane.

6. *WeatherLock G* should extend from eaves to a point 24" inside the exterior wall. This will place the *WeatherLock G* well above the maximum ice dam buildup line, in most areas. Consult local building code for specific requirements.
7. If a second course is needed, overlap the second course 3" onto the top of the first course taped selvage edge. The lap area must be firmly hand rolled to insure a watertight bond.
Continue this same application procedure for additional courses, as needed. Adhesive is not required.
8. Extra courses should be installed using the same application instructions as described in sections 3 and 4. Extra courses may also be installed with nails (18" on center) as needed and depending on the slope of the roof. Use hand pressure or a roller to smooth the lapped area to insure good adhesion.
9. Overlap at least 6" when the ends of two rolls meet.
10. Cover *WeatherLock G* with finish roofing material. Do not allow *WeatherLock G* to remain uncovered. Prolonged exposure to sun and weather will adversely affect this product's performance.

Precautions

1. *WeatherLock G* should be installed by a professional roofing contractor.
2. *WeatherLock G* is designed to be covered by shingles or other roofing material. Protection from sunlight is required to assure its long-term performance.
3. *WeatherLock G* is a moisture and vapor barrier. Since ice buildup is partially a function of ventilation, the spaces under the covered deck area and the attic space must be ventilated in accordance with FHA Minimum Property Standards and local building codes.
4. *WeatherLock G* is intended for exterior application only.
5. Apply *WeatherLock G* directly to the wood deck. Do not apply shingle underlayment beneath *WeatherLock G*.
6. Use extreme caution when installing *WeatherLock G*. The *WeatherLock* surface is slippery even when dry.
Use of Fall Protection is highly recommended. Consult OSHA for guidelines on Fall Protection (29 CFR 1926.500).
7. For best results, apply *WeatherLock G* when the air temperature is over 40°F (5°C) but below 100°F (38°C). If applied in temperatures below 40°F (5°C), *WeatherLock G* is stiffer and will not fully seal until it is warmed. If applied in temperatures above 100°F (38°C), it may become difficult to remove the release poly backing. If this situation should occur, move product into a shaded area until cool. Once cooled, the release poly backing can be easily removed.
8. Store *WeatherLock G* in a dry, well-ventilated area. Stand *WeatherLock G* upright. Do not store at 90°F (32°C) or warmer for extended periods of time.
9. When applying *WeatherLock G*, always follow local building codes and the shingle manufacturer's instructions for installation of its product.

WEATHERLOCK® SPECIALTY TILE & METAL WATERPROOFING BARRIER

For sloped residential buildings with wood decks

WeatherLock® underlayment installed between the roof deck and metal or tile roofing helps to lock out damage from wind-driven rain and ice damming. This exclusive Owens Corning Roofing composition is engineered for use under metal or tile.

Caution

Read and understand all instructions and precautions before applying WeatherLock underlayment.

For tile roof application

The standard maximum pitch for WeatherLock underlayment shall be 6:12 when tiles are loaded directly to the WeatherLock underlayment; loading boards are required on roof pitches greater than 6:12.

On slopes 2:12 to 6:12, battens are not required, although tiles should not be stacked higher than 10 tiles per stack.

Tiles shall be stored on battens on roof pitches greater than 6:12.

Deck Preparation

1. Owens Corning® WeatherLock underlayment should be applied on roofs having slopes of 2" rise minimum in 12" run or greater.

It can be applied on new construction or when re-roofing, provided existing roofing has been removed. Remove all old roofing down to the deck or, in new construction, apply over the new deck.

Sweep the deck surface to remove dirt and debris. The deck must be clean, smooth and dry before applying WeatherLock underlayment. Replace any damaged or rotted deck boards.

Eave Preparation

2. Along eaves, install metal drip edge under the WeatherLock underlayment. Along rakes, apply WeatherLock underlayment first, and put drip edge on top.

Note: When installing WeatherLock product over the entire roof deck, proper ventilation is required. Consult a design professional for proper ventilation requirements.

Installation

3. Unroll WeatherLock underlayment and cut into 10' to 20' lengths, depending on size of job. Allow it to relax for 3–5 minutes before installing.

Reroll each portion. Remove the first two feet of the release backer and press the product into place. Overlap the bottom edge (eave) by $\frac{1}{4}$ ". While supporting the roll with one hand, remove the release backer with the other hand and press or roll into place. WeatherLock underlayment may be secured with nails (18" on center); back nailing of WeatherLock product on slopes 3:12 or greater will be required.

Along a valley, WeatherLock underlayment can be cut lengthwise for easier handling. For maximum protection, the roll width should remain intact and extend 18" on either side of the valley. Peel back the poly backer sheet and press WeatherLock underlayment into place, working from the center of the valley or ridge outward in each direction. Always apply valleys starting at the low point and work upward. If an overlap is needed, be sure to overlap the previous piece by 4". WeatherLock underlayment should be applied in valleys before doing eave applications with membranes.

4. Extra courses should be installed using the same application instructions as described in Section 3. Extra courses may also be installed with nails (18" on center) as needed and depending on the slope of the roof. Use hand pressure or a roller to smooth the lapped area to ensure good adhesion.
5. Overlap at least 6" when the ends of two rolls meet. To ensure good adhesion at the end lap, apply asphalt roof cement approximately $\frac{1}{4}$ " thick, 3"–4" across the width of the

composite (excessive roof cement can have an adverse reaction to the product). Ensure that this is compliant with ASTM D4586 Type I & II. Good penetration of the primer is essential to the waterproofing integrity of the end lap. Apply heavy hand pressure or use a roller along the seam, overlapping the next roll.

6. Cover *WeatherLock* underlayment with finish roofing material. Do not allow *WeatherLock* underlayment to remain uncovered. Exposure to sun and weather for more than 90 days will adversely affect this product's performance.

Precautions

1. *WeatherLock* underlayment should be installed by a professional roofing contractor.
2. *WeatherLock* underlayment is designed to be covered by roofing material. Protection from sunlight is required to assure its long-term performance.
3. *WeatherLock* underlayment is a moisture and vapor barrier. The spaces under the covered deck area and the attic space must be ventilated in accordance with FHA Minimum Property Standards and local building codes.
4. *WeatherLock* underlayment is intended for exterior application only.
5. Apply *WeatherLock* underlayment directly to the wood deck. Do not apply shingle underlayment beneath *WeatherLock* underlayment.
6. Metal, tiles or shingles should not be installed over wrinkled or buckled *WeatherLock* underlayment.
7. Use extreme caution when installing *WeatherLock* underlayment. The *WeatherLock* underlayment surface is slippery even when dry. Use of fall protection is highly recommended. Consult OSHA for guidelines on fall protection (29 CFR 1926.500).

8. For best results, apply *WeatherLock* underlayment when the air temperature is over 40°F (5°C) but below 100°F (38°C). When temperatures are under 40°F (5°C), *WeatherLock* underlayment will not fully adhere until warmer temperatures. Store at room temperature prior to installing product in cold weather. If applied in temperatures above 100°F (38°C), the release poly backing may become difficult to remove. If this situation should occur, then move product into a shaded area until the *WeatherLock* underlayment is cool. Once cooled, the release poly backing can be easily removed.
9. Store *WeatherLock* underlayment in a dry, well-ventilated area. Stand *WeatherLock* underlayment upright. Do not store at 90°F (32°C) or warmer for extended periods of time.
10. When applying *WeatherLock* underlayment, always follow local building codes and the roofing manufacturer's instructions for installation of its product.

RHINOROOF® GRANULATED SELF-ADHERED ROOFING UNDERLAYMENT

RhinoRoof® Granulated is designed as a secondary water barrier for use on steep slope roofs (2:12 or greater) under; Asphalt Shingles, Composite Shingles, Slate, and Wood Shakes and Shingles.

STORAGE:

1. RhinoRoof® Granulated should be stored at room temperature, upright in the original cardboard packaging in a dry properly ventilated area. Keep product sheltered from the elements.
2. Only rolls destined for same-day use should be removed from their storage area.
3. For best results store in temperatures between 40°F (4.4°C) and 90°F (32°C). If room temperature storage is not available and product is at a temperature of 40°F (4.4°C) or less, move the product to a warm area prior to application. If product has been stored in temperatures above 90°F (32°C) it may become difficult to remove the release backing. If this situation should occur, move product into a shaded area until the product is cool. Once cooled, the release backing can be easily removed.

DECK PREPARATION:

1. Sweep the deck to remove dirt, debris, and any damaged or rotten wood must be replaced.
2. RhinoRoof® Granulated must be applied directly to minimum 3/8 inch-thick plywood, 7/16 inch-thick OSB decking, or minimum 6 inch-wide deck boards (gaps no greater than 1/4 inch) on roofs with a slope of 2:12 or greater.
3. For re-roofing projects replace any water damaged sheathing and sweep roof deck thoroughly removing dust, dirt and loose nails. Do not install over old roof covering.

APPLICATION:

1. For best results RhinoRoof® Granulated must be installed over a clean, smooth and dry roof deck.
2. For cold weather applications 40°F (4.4°C) or below, a primer should be

used and the laps blind nailed (see note 5 under application). The primer should be solvent or water based and meet ASTM D41 for asphalt based self-adhering membranes.

3. For steep slope applications (3:12 or greater) or when installing at temperatures greater than 100°F (38°C) it is recommended to blind nail the selvage edge area as per note 5 below under application.
4. RhinoRoof® Granulated is to be laid out horizontally (parallel) to the eaves with the printed side up, using 3 inch horizontal laps and 6 inch vertical laps with the lower edge of the RhinoRoof® Granulated flush with the outside of the drip edge. The lower edge of the underlayment is the edge that does not have a film selvage edge. End laps should be offset a minimum of 6 feet on adjacent courses.
5. On slopes greater than 6:12 after installation of each piece, overlap the 3 inch film selvage edge and, if necessary, secure with nails installed in the selvage edge spaced 12 inches on center. Blind nail with 3/8 inch head roofing nails of 1 inch or longer in the 3 inch selvage edge area. Consult local building codes for fastener requirements.
6. Always work from the low point to the high point of the roof. Apply the membrane in valleys before the membrane is applied to the eaves.
7. Cut the membrane into 15 foot to 20 foot lengths. Peel back 1-2 feet of release liner, align the membrane, and continue to peel the release liner from the membrane. Hand press or walk on, then follow with a 40 lb. or heavier weighted roller to smooth and secure the membrane. Hand rolling over the selvage edge and directly above the selvage edge using a minimum 4 inch-wide, 10 lb. roller is recommended. If a roller is not available or not considered safe, walk on all laps, and as much of the field area as possible to push the adhesive into the pours of the roof deck and overlap.

8. RhinoRoof® Granulated should be applied over the metal drip edge at the eaves unless otherwise specified by local codes. Along rakes, apply RhinoRoof® Granulated underlayment first, and install drip edge over the underlayment. Do not fold RhinoRoof® Granulated over the roof edge unless the edge is subsequently covered over by a drip edge or other flashing material.
9. In areas where ice damming can occur, install RhinoRoof® Granulated from the eave up the roof to a point not less than 24 inches inside the exterior wall. Consult your local building code for specific requirements.
10. For valley applications, peel the release liner; center the sheet over the valley and hand press in place from the center of the valley outward.
Note: It is very important RhinoRoof® Granulated stay in contact with the roof deck into and out of the valley area. RhinoRoof® Granulated should never be suspended or bridge a valley. It is recommended to follow up with a weighted roller or by walking on the surface. Give special attention to ALL perimeter edge areas.
11. If fasteners are removed leaving holes in the membrane or other penetrations are accidentally produced, they must also be patched.
12. Do not install fasteners through membrane over any unsupported areas of the structural deck, such as over joints between adjacent structural panels.
13. For geographies with high elevation, high wind or wind driven rain it is recommended to cover the entire roof deck with RhinoRoof® Granulated.
2. Follow the recommendations of the roof covering manufacturer, Asphalt Roofing Manufacturer's Association (for asphalt shingles).
3. RhinoRoof® Granulated is not designed for indefinite outdoor exposure. Final roofing should be installed within 30 days of underlayment installation.
4. Depending on roof pitch and surface conditions, loading cleats (battens) may be required to support roofing materials placed on the roof. Remember to seal the fastener holes that secured the cleats/battens after they have been removed.
5. Protect completed roof areas to avoid damage during roof installation and material transportation by installing protective boardwalks to enable passage of people, equipment and products.
6. Be careful not to load too much material on the roof deck in one area. Disburse the weight over structural supports where possible

CAUTION - READ GOOD SAFETY PRACTICES BELOW

As with any roofing product, always follow safe roofing codes & practices (OSHA) and always use and wear fall protection devices when working on roofs. Release liners are slippery and should be removed from work area immediately after application. Use caution when walking or standing on RhinoRoof® Granulated as slip resistance may vary with surface conditions, weather, footwear and roof pitch. Failure to use proper safety gear and footwear can result in serious injury.

PRECAUTIONS:

1. RhinoRoof® Granulated is a moisture and vapor barrier and therefore must be installed above a properly ventilated space(s). Follow ALL building codes applicable to your geographical region and structure type.

TITANIUM® PSU30 SYNTHETIC ROOFING UNDERLAYMENT

Titanium® PSU30 is designed as a secondary water barrier for use on steep slope roofs (2:12 or greater) under asphalt shingles, composite shingles, metal roofing, concrete and clay tile, slate, and wood shakes. For application under copper or zinc roofing materials please 1-800-ROOFING (1-800-766-3464).

CAUTION

Read and understand all instructions and precautions before applying Titanium® PSU30 underlayment. Check local building codes prior to application of this product. Follow the recommendations of the roof covering manufacturer, Asphalt Roofing Manufacturer's Association (for asphalt shingles), Tile Roof Institute (for clay or concrete roof tiles), and the Metal Roofing Alliance (for metal roof panels).

DECK PREPARATION

Titanium® PSU30 underlayment should be applied on roofs having slopes of 2:12 or greater. This product can be applied on new construction or when re-roofing, provided existing roofing has been removed. The deck must be clean, smooth and dry before applying Titanium® PSU30 underlayment. Remove all old roofing down to the deck or, in new construction, apply over the new deck. Sweep the deck surface to remove dirt and debris. Replace any damaged or rotted deck boards.

Deck Edge Preparation

Along eaves, install metal drip edge under the Titanium® PSU30 underlayment unless otherwise directed by local building codes. Along rakes, apply Titanium® PSU30 underlayment first, and put drip edge on top.

For Tile Roof Application

The maximum roof slope for Titanium® PSU30 underlayment shall be 2:12 when tiles are loaded directly to the Titanium® PSU30 underlayment; loading boards are required on roof pitches greater than 2:12.

Note: When installing Titanium® PSU30 underlayment over the entire roof deck, proper ventilation is required. Consult a design professional and local building codes for ventilation requirements.

INSTALLATION

1. Insure that decking substrate is acceptable to roof covering manufacturer.
2. Unroll Titanium® PSU30 underlayment and cut into manageable lengths no more than 15 - 20 feet.
3. Allow it to relax for 3–5 minutes before installing.
4. Reroll each section.
5. Start at the eaves, laying the Titanium® PSU30 parallel to the eaves edge, with the lower edge of the Titanium® PSU30 flush with the outside of the primed drip edge. The lower edge of the underlayment is the edge that does not have a selvage edge.
6. After installation of each piece, remove the release lining from the selvage and, if necessary, secure with nails installed in the selvage spaced 12 inches on center. This fastening is required when Titanium® PSU30 is installed on slopes of 3:12 or greater. Consult local building codes for fastener requirements.
7. The entire roof surface should be rolled after installation of the Titanium® PSU30 using a minimum 40 lb. roller. Hand rolling over the selvage and directly above the selvage using a minimum 4 inches wide, minimum 10 lb. roller is recommended.
8. Overlap at least 6 inches when the ends of two rolls meet. To ensure good adhesion at the end lap, apply a minimum 6 inches width of a solvent-based asphaltic primer that complies with ASTM D41 across the width of the sheet using a roller, brush, or aerosol primer. As an alternative, asphalt roof cement that complies with ASTM D4586 may be used, approximately 1/8 inch thick (excessive roof cement can have an adverse reaction to the product). Apply heavy hand pressure or use a roller along the seam overlapping the next roll.
9. End laps should be offset a minimum of 6 inches on adjacent courses.

10. Along a valley, Titanium® PSU30 underlayment can be cut lengthwise for easier handling. For maximum protection, the roll width should remain intact and extend 18 inches on either side of the valley. Remove the release backer and press Titanium® PSU30 underlayment into place, working from the center of the valley or ridge outward in each direction. Always apply valleys starting at the low point and work upward. If an overlap is needed, be sure to overlap the previous piece by minimum 4 inches. Titanium® PSU30 underlayment should be applied in
 8. For best results, apply Titanium® PSU30 underlayment when the air temperature is over 40°F (5°C) and rising, but below 100°F (38°C). When temperatures are under 40°F (5°C), Titanium® PSU30 underlayment will not fully adhere. Store at room temperature prior to installing product in cold weather. If applied in temperatures above 100°F (38°C), or exposed to direct sunlight, the release backing may become difficult to remove. If this situation should occur, move the product into a shaded area until the Titanium® PSU30 underlayment is cool. Once cooled, the release backing can be easily removed.

For further detail on various installation methods, please call 1-800-ROOFING (1-800-766-3464)

PRECAUTIONS

1. Cover Titanium® PSU30 underlayment with finish roof covering. Do not allow Titanium® PSU30 underlayment to remain uncovered. Exposure to sun and weather for more than 180 days may adversely affect this product's performance.
2. Titanium® PSU30 underlayment should be installed by a professional roofing contractor.
3. Titanium® PSU30 underlayment is a moisture and vapor barrier. The spaces under the covered deck area and the attic space must be ventilated in accordance with local building codes.
4. Titanium® PSU30 underlayment is intended for exterior roof application only and is not intended for use on vertical surfaces.
5. Apply Titanium® PSU30 underlayment directly to the wood deck. Do not apply any underlayment beneath Titanium® PSU30 unless required to do so by local codes.
6. Roof coverings should not be installed over wrinkled or buckled Titanium® PSU30 underlayment.
7. Use extreme caution when installing Titanium® PSU30 underlayment. The Titanium® PSU30 underlayment surface may be slippery even when dry. Use of fall protection is highly recommended. Consult OSHA for guidelines on fall protection (29 CFR 1926.500).
9. Store Titanium® PSU30 underlayment in a dry, well-ventilated area. Stand Titanium® PSU30 underlayment upright. Do not store at 90°F (32°C) or warmer for extended periods of time. Do not store in direct sunlight.
10. When applying Titanium® PSU30 underlayment, always follow local building codes and the roof covering manufacturer's instructions for installation of this product.
11. When working on the roof, use all necessary safety precautions and guidelines in accordance with proper roofing trade practices.

FIBERGLAS™ REINFORCED FELT

Owens Corning® Fiberglas™ Reinforced Felt should be applied to a properly prepared dry deck that is smooth, clean and free from any depressions, projections or protruding nails. Roof decks should be structurally sound and meet or exceed minimum requirements of the deck manufacturer and local codes.

Slopes 4" in 12" or more

Always lay the felt underlayment parallel to the eaves, lapping each course at least 2" over the underlying course. Felt underlayment should not run perpendicular to the eaves. Secure the felt underlayment with nails to hold it in place. (See Fig. 1.) Nails should be driven straight and flush with the surface. If two or more pieces are required to continue a course, lap the ends at least 4". End laps in a succeeding course should be located at least 6' from end laps in the preceding course. Lap the felt underlayment a minimum of 6" from both sides over all hips, ridges and valleys. Where the roof meets a vertical surface, carry the felt underlayment at least 4" up the surface.

Slopes 2" in 12" to less than 4" in 12"

On low-slope applications, cover the deck with two layers of non-perforated asphalt saturated felt underlayment. (See Fig. 2.) Begin by fastening a 19" wide strip of felt underlayment placed along the eaves. Place a full width sheet over the starter with a long edge placed along the eave and completely overlapping the initial starter course. All succeeding courses will be a minimum of 36" wide and should be positioned to overlap the preceding course by 19". Secure each course by only enough fasteners to hold it in place until the shingles are applied. End laps should be 12" wide and located at least 6' from end laps in the preceding course.

Fig. 1 Standard Slope

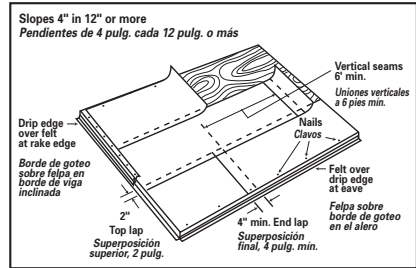
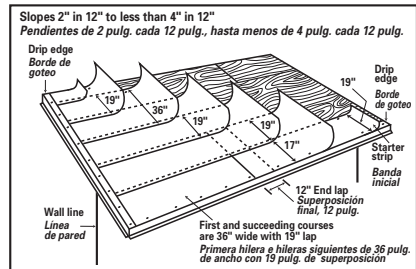

Fig. 2 Low Slope



PROARMOR® SYNTHETIC ROOF UNDERLAYMENT

INSTALLATION INSTRUCTIONS

Owens Corning® ProArmor® Synthetic Roof Underlayment should be applied to a properly prepared dry deck that is smooth, clean and free from any depressions, projections, or protruding nails. Acceptable roof deck materials for application are minimum $\frac{3}{8}$ " plywood or minimum $\frac{7}{16}$ " OSB. Roof decks should be structurally sound and meet or exceed minimum requirements of the roof deck manufacturer and local building codes. ProArmor® underlayment is designed for use under asphalt shingles only and must be covered within 30 days of application.

Always follow safe roofing practices and OSHA safety requirements. Always wear and use fall protection devices when working on roofs. Use caution when walking or standing on ProArmor® underlayment in wet or dusty conditions that may reduce traction. Failure to use proper safety equipment and footwear can result in serious injury.

Fasteners

If the roof will not be covered with asphalt shingles on the same day, ProArmor® underlayment must be attached to the roof deck using plastic or steel cap fasteners having a minimum 1" diameter cap. Roofing nails and pneumatic nail guns may be used for same day installations for all slopes. Staples may be used for same day installations on slopes 2:12 to 12:12. All fasteners should be driven straight and flush with the surface. Consult local building codes for fastener type and spacing requirements.

Lap Requirements – All Slopes

If two or more pieces are required to continue a course, lap the ends at least 4" (must be at least 12" for slopes 2:12 to less than 4:12). End laps in a succeeding course should be located at least 6' from laps in the preceding course. Lap ProArmor™ underlayment a minimum of 6" from both sides over all hips, ridges and valleys. Where the roof meets a wall, extend ProArmor® underlayment a minimum 4" up the wall.

Fig 1. Minimum Fastening Locations for Same Day Coverage Using Roofing Nails, Pneumatic Nail Guns or Cap Nails Fig 1.

Fig 1. Ubicaciones mínimas de sujetadores para cobertura el mismo día usando clavos para techos, pistolas neumáticas o clavos con capuchón

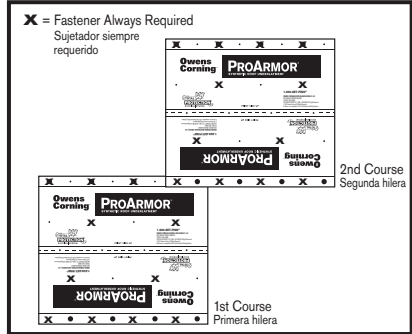
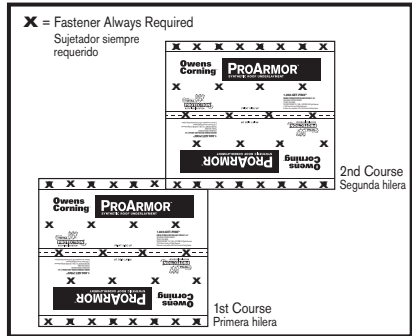

Fig 2. Minimum Fastening Locations for Same Day Coverage Using Staples for Slopes 4:12 to 12:12 Only

Fig 2. Ubicaciones mínimas de sujetadores para cobertura el mismo día usando grapas para pendientes de 4:12 a 12:12 solamente



Slopes 4:12 or Greater

Always lay ProArmor® underlayment parallel to the eaves, lapping each course at least 3" over the underlying course. For same day coverage, minimum fastening locations for roofing nails, pneumatic nail guns or cap nails are shown in Fig. 1 and staples in Fig. 2. If required, additional fasteners can be used for same day coverage. See Fasteners section for additional details.

If ProArmor® underlayment will not be covered on the same day with asphalt shingles (extended exposure up to 30 days), use only plastic or steel cap fasteners having a minimum 1" diameter cap for all slopes. Fasten in both the overlapping area and the field area of ProArmor® underlayment.

Additional fasteners may be required in high wind regions per local building codes. See Fig. 3 and Fasteners section for details.

Slopes 2:12 to less than 4:12

On all lower slope applications, cover the deck with two layers of ProArmor® underlayment. Roofing nails, pneumatic nail guns and staples may be used for same day installations. If ProArmor® underlayment will not be covered on the same day with asphalt shingles (extended exposure up to 30 days), use only plastic or steel cap fasteners having a minimum 1" diameter cap. Begin by fastening a 22" wide strip of ProArmor™ underlayment along the eaves with the minimal fasteners needed to hold the course in place. Place a full-width sheet over the 22" course with the long edge placed along the eaves and completely overlapping the initial starter course. All succeeding courses will be a minimum of 42" wide and should be positioned to overlap the preceding course by 22" (to lowest solid centerline). Additional fasteners may be required in high wind regions per local building codes. See Fig. 4 and Fasteners section for details.

⚠ CAUTION

Caution: Roof surface may be slippery, especially when dusty, wet or icy. Use a fall protection system when installing. Wear soft-soled shoes. Walk with care. Falling Hazard: Secure area below work and materials on roof. Unsecured materials may slide when placed on roof. Place on level plane or secure to prevent sliding. Wear a hard hat. Caution: Safety glasses should always be worn when using power tools. Wear gloves when installing to avoid cuts and abrasions.

Fig. 3. Minimum Fastening Locations For Extended Exposure on Slopes 4:12 or Greater

Fig. 3. Ubicaciones mínimas de sujeción para exposición extendida en pendientes de 4:12 o superiores

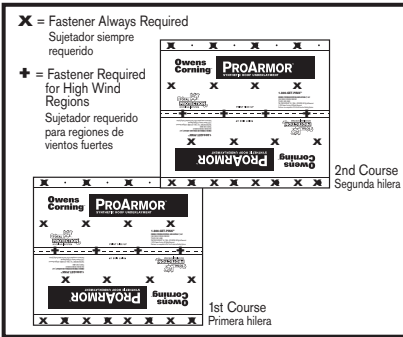
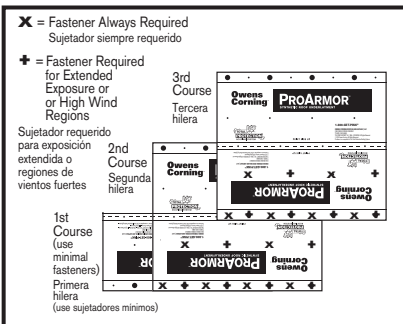

Fig. 4. Fastening Locations for Slopes 2:12 to less than 4:12

Fig. 4. Ubicaciones de sujeción para pendientes de 2:12 a menos de 4:12



DECK DEFENSE® HIGH PERFORMANCE ROOF UNDERLAYMENT

INSTALLATION INSTRUCTIONS

Owens Corning® Deck Defense® High Performance Roof Underlayment should be applied to a properly prepared dry deck that is smooth, clean and free from any depressions, projections, or protruding nails. Roof decks should be structurally sound and meet or exceed minimum requirements of the deck manufacturer and local codes.

Always follow safe roofing practices and OSHA safety requirements. Always use and wear fall protection devices when working on roofs. Some examples are toe boards, rope and harness, and soft-sole footwear. Use caution when walking or standing on Owens Corning® Deck Defense® High Performance Roof Underlayment when wet or dusty conditions exist that may reduce traction. Failure to use proper safety gear and footwear can result in serious injury.

NOTE: Owens Corning® Deck Defense® High Performance Roof Underlayment must be attached to the roof deck using plastic or steel cap fasteners having a minimum of 1" diameter cap.

Slopes 4' in 12" or more

Always lay Deck Defense underlayment parallel to the eaves, lapping each course at least 3" over the underlying course. Deck Defense underlayment should not run perpendicular to the eaves. Secure Deck Defense underlayment with cap nails that are 1" in diameter placed in the printed nail areas located on Deck Defense underlayment. See Fig. 1.

Fig.1 For Standard Application
Fig.1 Para la instalación estándar

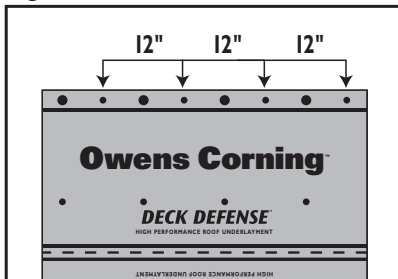

When installing underlayment over an extended period up to 180 days, cap nails should be placed in both the overlapping area and also the center area of the underlayment. See Fig. 2. Nails should be driven straight and flush with the surface. If two or more pieces are required to continue a course, lap the ends at least 4'. End laps in a succeeding course should be located at least 6' from laps in the preceding course. Lap Deck Defense underlayment a minimum of 6" from both sides over all hips, ridges and valleys. Where the roof meets a vertical surface, carry Deck Defense underlayment at least 4" up the surface.

Fig.2 For Application over an Extended Period
Fig.2 Para la instalación durante un tiempo prolongado

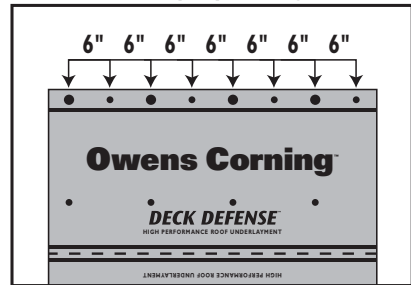

Slopes 2" in 12" to less than 4" in 12"

On low slope applications, cover the deck with two layers of Deck Defense underlayment. See Fig. 3. Begin by fastening a 25"-wide strip of Deck Defense underlayment placed along the eaves. Place a full-width sheet over the starter with a long edge placed along the eave and completely overlapping the initial starter course. All succeeding courses will be a minimum of 48" wide and should be positioned to overlap the preceding course by 25". Secure each course with cap nails 1" in diameter placed in the nailing area every 6" in the overlap area and 12" in the center of Deck Defense underlayment to hold it in place until the shingles are applied. End laps should be 12" wide and nailed every 4" from the edge. Also ensure end laps are located at least 6' from end laps in the preceding course.

Fig.3 Low Slope Application
Fig.3 Instalación en poca pendiente

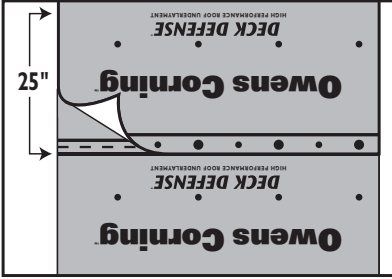

Caution: Roof surface may be slippery, especially when wet or icy. Use a fall protection system when installing. Wear rubber-soled shoes. Walk with care.

Falling Hazard: Secure area below work and materials on roof. Unsecured materials may slide on roof. Place on level plane or secure to prevent sliding. Wear a hard hat.

Caution: Safety glasses should always be worn when cutting the roof with a power tool.

Wear gloves when installing to avoid cuts and abrasions.

RHINOROOF® U20 SYNTHETIC ROOFING UNDERLAYMENT

RhinoRoof® U20 is a water and vapor barrier and therefore must be installed above a properly ventilated space(s). Follow ALL building codes applicable to your geographical region and structure type as it is considered a vapor barrier.

Always follow safe roofing practices and OSHA safety requirements. Always wear and use fall protection devices when working on roofs. Use caution when walking or standing on RhinoRoof® U20 underlayment in wet or dusty conditions that may reduce traction. Failure to use proper safety equipment and footwear can result in serious injury.

DECK PREP

RhinoRoof® U20 should be applied to a properly prepared dry deck that is smooth, clean and free from any depressions, projections, or protruding nails. Acceptable roof deck materials are minimum 3/8 inch plywood, minimum 7/16 inch OSB, or minimum 6 inch roof deck boards. Roof decks should be structurally sound and meet or exceed minimum requirements of the roof deck manufacturer and local building codes.

USE

RhinoRoof® U20 must be covered by primary roofing within 90 days of application. U20 is designed for use under asphalt or synthetic shingles, metal in residential applications, and cedar shakes that have been primed.

APPLICATION

Slopes from 4:12 and higher: RhinoRoof® U20 is to be laid out horizontally (parallel) to the eave with the printed side up. Horizontal laps should be 4 inches and vertical laps should be 6 inches and anchored approximately 1 inch in from the edge. End laps in a succeeding course should be located at least 6 feet from laps in the preceding course.

Slopes 2:12 to less than 4:12: Cover the deck with two layers of RhinoRoof® U20. Begin by fastening a 22 inch wide strip of RhinoRoof® U20 along the eaves with the minimal fasteners need to hold the course in place. Place a full-width sheet over the

22 inch course and overlap each successive course by 50% plus 1 inch. Additional fasteners may be required in high-wind regions per local building codes. Vertical lap requirements are the same as 4:12 and higher slopes. Slopes less than 2:12: RhinoRoof® U20 is not recommended for use.

FASTENERS

Provided there is no rain or high winds, RhinoRoof® U20 can be anchored with staples, cap staples or corrosive resistance 3/8 inch head X 1 inch leg roofing nails (ring shank preferred, smooth leg acceptable), when covered with primary roofing on the same day.

If RhinoRoof® U20 will not be covered on the same day and up to 90 days, then product must be attached to the roof deck using a minimum 1 inch diameter plastic or metal cap roof nail (ring shank preferred, smooth leg acceptable). Miami-Dade approved tin tags/metal caps are also acceptable, and it is recommended for best performance to use with the rough edge facing up. For extended exposure, it is required that RhinoRoof® U20 be anchored in all locations printed on the facer. Consult local building codes for fastener type and spacing requirements.

For extended exposure conditions where driving rain or strong winds are expected, it is recommended to take additional precautions such as doubling the lap widths. Alternatively or in addition to, a compatible sealant could be used between the laps or a peel and stick tape could be applied to the overlaps.

ANCHORING

All anchoring nails must be flush, 90 degrees to the roof deck, and tight with the underlayment surface and the structural roof deck. Where seams and joints require sealant or adhesive, use a low solvent plastic roofing cement meeting ASTM D-4586 Type 1, or Federal Spec SS-153 Type 1 such as Karnak, Henry, DAP, MB, Geocel or equivalent. Acceptable alternatives are butyl rubber, urethane, and EPDM based caulk or tape sealant.

TITANIUM® UDL25 SYNTHETIC ROOFING UNDERLAYMENT

Titanium® UDL25 is an air, water and vapor barrier (.06 perms) and therefore should be installed above a properly ventilated space(s). It is recommended to follow all building codes applicable to your geographical region and structure type.

DECK PREPARATION

All protrusions from the deck area must be removed and ensure the deck has no voids, damaged or unsupported areas. Deck surface should be free of debris, dry and moisture free.

USE

Titanium® UDL25 must be covered by primary roofing within 180 days of application. UDL25 is designed for use under; asphalt and synthetic shingles, metal roofing, and cedar shakes.

APPLICATION

For slopes 4:12 and higher UDL25 is to be laid out horizontally (parallel) to the eave with the printed side up. Horizontal laps should be 4" and vertical laps should be 6" and anchored approximately 1" in from the edge. For low slope applications it is recommended to overlap 50% plus 1", for complete definition of low slope and guidelines consult authorities having jurisdiction. UDL25 product is not recommended for slopes less than 2:12. The use of a roofing hammer, hatchet hammer, pneumatic air or gas driven fastener tools is acceptable. The use of a straight edge cutting knife is recommended.

FASTENERS

For same day coverage with primary roofing UDL25 can be anchored with corrosive resistant 3/8" head x 1" leg roofing nails (ring shank preferred, smooth leg acceptable). The use of every other anchoring location printed on the product is also acceptable.

DO NOT USE STAPLES: use of staples to penetrate UDL25 will void warranty.

ANCHORING

All anchoring nails must be flush, 90 degrees to the roof deck, and tight with the underlayment surface and the structural roof deck. Where seams and joints require sealant or adhesive use a low solvent

plastic roofing cement meeting ASTM D-4586 Type 1, or Federal Spec SS-153 Type 1 such as Karnak, Henry, DAP, MB, Geocel or equivalent. Acceptable alternatives are butyl rubber, urethane, and EDPM based caulk or tape sealant.

EXTENDED EXPOSURE

If Titanium® UDL25 product will be exposed longer than 1 day but less than 5 days then it is recommended to anchor using corrosive resistant 3/8" head x 1" leg roofing nails (Ring shank preferred). For exposure more than 5 days and up to 180 days UDL25 product must be anchored with 1" plastic or metal cap smooth or ring shank roofing nails. Miami-Dade approved tin tags or metal caps are also acceptable, and it is recommended for best performance to use with the rough edge facing up. For extended exposure it is always recommended to anchor on every printed position on the facer. Note: UDL25 is not designed for indefinite outdoor exposure. For extended exposure conditions where driving rain or strong winds are expected it is recommended to take additional precautions such as doubling the lap widths. Alternately or in addition to a compatible sealant could be used between the laps or a peel and stick tape could be applied to the overlaps.

CAUTION - READ GOOD SAFETY PRACTICES BELOW

Good safety practices should be followed on steep slope roofs, such as use of tie-offs, toe boards, ladders and/or safety ropes and personal body harnesses. Follow OSHA guidelines. Slip resistance may vary with surface conditions from debris that accumulates, weather, footwear and roof pitch. Failure to use proper safety gear can result in serious injury. Depending on roof pitch and surface conditions, blocking may be required to support materials on the roof and is good safety practice. Remember to seal the nail holes after removing blocking.

TITANIUM® UDL30 PROFESSIONAL GRADE SYNTHETIC ROOFING UNDERLAYMENT

Titanium® UDL30 is an air, water and vapor barrier (.06 perms) and therefore should be installed above a properly ventilated space(s). It is recommended to follow all building codes applicable to your geographical region and structure type.

DECK PREPARATION

All protrusions from the deck area must be removed and ensure the deck has no voids, damaged or unsupported areas. Deck surface should be free of debris, dry and moisture free.

USE

Titanium® UDL30 must be covered by primary roofing within 180 days of application. UDL30 is designed for use under; asphalt and synthetic shingles, metal roofing, and cedar shakes.

APPLICATION

For slopes 4:12 and higher UDL30 is to be laid out horizontally (parallel) to the eave with the printed side up. Horizontal laps should be 4" and vertical laps should be 6" and anchored approximately 1" in from the edge. For low slope applications it is recommended to overlap 50% plus 1", for complete definition of low slope and guidelines consult authorities having jurisdiction. UDL30 product is not recommended for slopes less than 4:12. The use of a roofing hammer, hatchet hammer, pneumatic air or gas driven fastener tools is acceptable. The use of a straight edge cutting knife is recommended.

FASTENERS

For same day coverage with primary roofing UDL30 can be anchored with corrosive resistant 3/8" head x 1" leg roofing nails (ring shank preferred, smooth leg acceptable). The use of every other anchoring location printed on the product is also acceptable.

DO NOT USE STAPLES: use of staples to penetrate UDL30 will void warranty.

ANCHORING

All anchoring nails must be flush, 90 degrees to the roof deck, and tight with the underlayment surface and the structural roof deck. Where seams and joints require sealant or adhesive use a low solvent

plastic roofing cement meeting ASTM D-4586 Type 1, or Federal Spec SS-153 Type 1 such as Karnak, Henry, DAP, MB, Geocel or equivalent. Acceptable alternatives are butyl rubber, urethane, and EPDM based caulk or tape sealant.

EXTENDED EXPOSURE

If Titanium® UDL30 product will be exposed longer than 1 day but less than 5 days then it is recommended to anchor using corrosive resistant 3/8" head x 1" leg roofing nails (Ring shank preferred). For exposure more than 5 days and up to 180 days UDL30 product must be anchored with 1" plastic or metal cap smooth or ring shank roofing nails. Miami-Dade approved tin tags or metal caps are also acceptable, and it is recommended for best performance to use with the rough edge facing up. For extended exposure it is always recommended to anchor on every printed position on the facer. Note: UDL30 is not designed for indefinite outdoor exposure. For extended exposure conditions where driving rain or strong winds are expected it is recommended to take additional precautions such as doubling the lap widths. Alternately or in addition to a compatible sealant could be used between the laps or a peel and stick tape could be applied to the overlaps.

CAUTION - READ GOOD SAFETY PRACTICES BELOW

Good safety practices should be followed on steep slope roofs, such as use of tie-offs, toe boards, ladders and/or safety ropes and personal body harnesses. Follow OSHA guidelines. Slip resistance may vary with surface conditions from debris that accumulates, weather, footwear and roof pitch. Failure to use proper safety gear can result in serious injury. Depending on roof pitch and surface conditions, blocking may be required to support materials on the roof and is good safety practice. Remember to seal the nail holes after removing blocking.

TITANIUM® UDL50 SYNTHETIC ROOFING UNDERLAYMENT

Titanium® UDL50 is an air, water and vapor barrier (.06 perms) and therefore should be installed above a properly ventilated space(s). It is recommended to follow all building codes applicable to your geographical region and structure type.

DECK PREPARATION

All protrusions from the deck area must be removed and ensure the deck has no voids, damaged or unsupported areas. Deck surface should be free of debris, dry and moisture free.

USE

Titanium® UDL50 must be covered by primary roofing within 180 days of application. UDL50 is designed for use under; Asphalt Shingles, Synthetic Shingles, Metal roofing, Tiles, Slate and Cedar Shakes.

APPLICATION

For slopes 4:12 and higher UDL50 is to be laid out horizontally (parallel) to the eave with the printed side up. Horizontal laps should be 4" and vertical laps should be 6" and anchored approximately 1" in from the edge. For low slope applications it is recommended to overlap 50% plus 1", for complete definition of low slope and guidelines consult authorities having jurisdiction. UDL50 product is not recommended for slopes less than 4:12. The use of a roofing hammer, hatchet hammer, pneumatic air or gas driven fastener tools is acceptable. The use of a straight edge cutting knife is recommended.

FASTENERS

For same day coverage with primary roofing UDL50 can be anchored with corrosive resistant 3/8" head x 1" leg roofing nails (ring shank preferred, smooth leg acceptable). The use of every other anchoring location printed on the product is also acceptable.

ANCHORING

All anchoring nails must be flush, 90 degrees to the roof deck, and tight with the underlayment surface and the structural roof deck. Where seams and joints require sealant or adhesive use a low solvent plastic roofing cement meeting ASTM D-4586 Type 1, or Federal Spec SS-153

Type 1 such as Karnak, Henry, DAP, MB, Geocel or equivalent. Acceptable alternatives are butyl rubber, urethane, and EDPM based caulk or tape sealant.

EXTENDED EXPOSURE

If Titanium® UDL50 product will be exposed longer than 1 day but less than 5 days then it is recommended to anchor using corrosive resistant 3/8" head x 1" leg roofing nails (Ring shank preferred). For exposure more than 5 days and up to 180 days UDL50 product must be anchored with 1" plastic or metal cap smooth or ring shank roofing nails. Miami-Dade approved tin tags or metal caps are also acceptable, and it is recommended for best performance to use with the rough edge facing up. For extended exposure it is always recommended to anchor on every printed position on the facer. Note: UDL50 is not designed for indefinite outdoor exposure. For extended exposure conditions where driving rain or strong winds are expected it is recommended to take additional precautions such as doubling the lap widths. Alternately or in addition to a compatible sealant could be used between the laps or a peel and stick tape could be applied to the overlaps.

CAUTION - READ GOOD SAFETY PRACTICES BELOW

Good safety practices should be followed on steep slope roofs, such as use of tie-offs, toe boards, ladders and/or safety ropes and personal body harnesses. Follow OSHA guidelines. Slip resistance may vary with surface conditions from debris that accumulates, weather, footwear and roof pitch. Failure to use proper safety gear can result in serious injury. Depending on roof pitch and surface conditions, blocking may be required to support materials on the roof and is good safety practice. Remember to seal the nail holes after removing blocking.

STARTER SHINGLE ROLL

FOR USE AT EAVE & RAKE



Cut Time—Not Tabs

Starter Shingle Roll from Owens Corning eliminates the need for cutting shingle tabs or inverting them to create a starter row. So you save time.

Easy Application

Application is a snap too. Simply apply a single course of Starter Shingle Roll along a clean, dry and smooth eave line, after removing the release sheet. Apply the Starter Shingle Roll directly onto the WeatherLock® underlayment or a layer of felt. Once it is pressed into place, you're ready to begin shingling.

The Starter Shingle Roll advantages:

- Eliminates time-consuming tab cutting or shingle flopping
- Comes in handy individual rolls, measuring 7.2" wide x 33'4" long (0.183m x 10.18m)
- Easy peel-and-stick application
- Requires no special tools, hardware or training
- Compatible with most Owens Corning® shingles, see back for application instructions
- Meets CCMC 13403-R

Before installing this product, check roofing manufacturer's application instructions and local building codes for their roofing requirements.

Starter Shingle Roll:

1. **Application:** Align Starter Shingle Roll with eave & rake edge granular side up with the seal strip closest to the outer edge of the roof. Remove release backer and press to assure full adhesion to the underlayment. For rake

application, install drip edge first before applying. See Fig. 1

NOTE: When rolling out the starter roll ensure the product is laying flat with no humps before pressing into place. For best results, keep the starter roll at room temperature prior to application. When the starter is used with 3 tab shingles, the installer must ensure that nails in the starter are not exposed between the cut outs of the overlaying shingle.

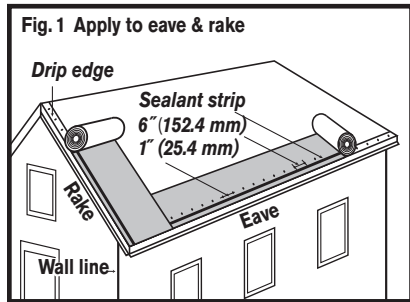

Fig. 1 Apply to eave & rake

2. Nail placement, when required to obtain max wind warranty for roofing shingles, are installed 1" (25.4 mm) above the sealant strip and spaced every 6" (152.4 mm) along the eave.
3. Apply shingles once Starter Shingle Roll is installed. Apply shingles according to the shingle manufacturer's instructions.

Precautionary Notes:

The manufacturer will not be responsible for problems resulting from any deviation from the recommended application instructions and the following precautions:

Storage: Store this product in a dry, well-ventilated area and stand upright. Do not store for extended periods over 90°F (32°C).

Nails must be corrosion-resistant, 11- or 12-gauge, with heads at least 3/8" (9.5 mm) in diameter.

All Fasteners must penetrate at least 3/4" (19.0 mm) into the wood deck or completely through plywood sheathing.

STARTER STRIP SHINGLE

Goes on right—right away

Starter Strip shingle from Owens Corning Roofing – eliminates the need for cutting shingle tabs to create a starter row, helping to save installation time and money! It's a component of the Owens Corning® Total Protection Roofing System®^A.



1. Starter Strip is packaged two pieces per shingle, 16 shingles per bundle, 105 lineal feet.
2. Perforation down the center allows for easy separation.
3. Once apart, the Starter Strip shingles should be aligned next to one another with the sealant toward the eave.

Starter Strip shingle advantages:

Speeds installation and helps improve safety. Starter Strip shingle eliminates the need to cut off tabs or headlap.

Saves labor. It's easy for a single person to position Starter Strip shingle on the roof.

Maximum compatibility. Use with any shingle that has an exposure of up to 6".

Improves job quality. Puts the sealant appropriately at the eaves.

Cost savings. There's no need to cut down 3-tab shingles to use as a starter strip.

Clean look. Starter Strip shingle provides a straight edge at the eave and along the rake.

Exceptional bonding strength. Continuous sealant ensures an effective seal between the starter and the first course of shingles.

Convenient. One (1) bundle provides 1 square of material (105 lineal feet of actual coverage).

Application Instructions

Owens Corning® Starter Strip can be used with any shingle that has an exposure of

up to 6". Starter Strip shingles cannot be used with Owens Corning® Berkshire®, Woodmoor® or Woodcrest® shingles.

Installation of Starter Strip shingle

Starter Strip shingle is designed to be broken into two pieces, and each piece has its own sealant strip. When separated, each starter shingle is 6 $\frac{5}{8}$ " x 39 $\frac{3}{8}$ ", and each bundle will cover approximately 105 lineal feet. See Fig. 1.

This starter can be used with shingles that have an exposure of no more than 6"; if the exposure is greater than 6", a full starter (13 $\frac{1}{4}$ " x 39 $\frac{3}{8}$ ") would be required. See Fig. 1.

Fig. 1 Starter Strip Shingle

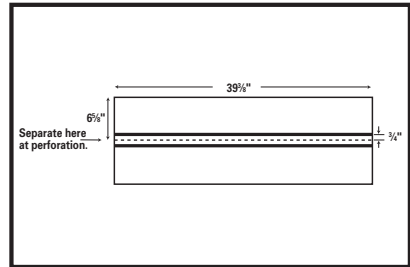

1. Start first Starter Strip shingle with 6" removed from the rake edge and flush with the drip edge. Starter shingle can extend no greater than 3/4" beyond the edge of the eave. Use 5 fasteners placed 2" to 3" from the edge of the eave. See Fig. 2.

Fig. 2 Starter Strip Shingle Application

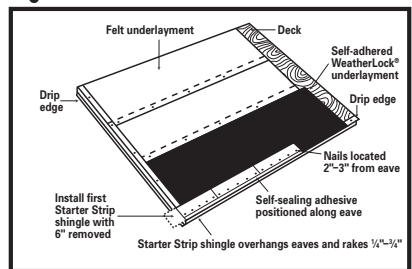

2. During application, the installer must ensure that when the starter is applied, the overlying shingles' end joints do

not line up with the starter end joints. End joints must be a minimum of 4" from the overlaying shingle.

- When the starter is used with 3-tab shingles, the installer must ensure that nails in the starter are not exposed between the cutouts of the overlaying shingle. Each starter shingle should be cut to match the length of the 3-tab shingle being installed. Otherwise, the 6" offset will not match with shingles. Offsets are required to be a minimum of 4"
- When installing Owens Corning® Oakridge®/TruDefinition® Oakridge® shingles for maximum wind warranty, Starter Strip shingles are required along both the eave and rake edge.

Caution

Roof surface may be slippery: Especially when wet or icy. Use a fall protection system when installing. Wear rubber-soled shoes. Walk with care.

Falling hazard: Secure area below work and materials on roof. Wear a hard hat.

Notice

It is important that attic space be properly ventilated to maintain product performance and to prevent damage from moisture condensation and excessively high attic temperatures. In this regard, FHA and National Building Code Minimum Property Standards must be met.

Product Specifications

Size	13¼" x 39⅜" (337 mm x 1000 mm)
Piece Size	6⅝" x 39⅜" (168 mm x 1000 mm)
Shingles per Bundle	16
Pieces per Bundle	32 (6⅝" x 39⅜" [168 mm x 1000 mm])
Lineal Feet per Bundle	Approximately 105 (32.0 m)

Applicable Standards and Codes

ASTM D3462

ASTM D3161 (Class F Wind Resistance)

ASTM E108/UL 790 (Class A Fire Resistance)*

Florida Product Approval (FL10674)

UL ER2453-01

STARTER STRIP PLUS SHINGLE

Goes on right—right away

Owens Corning® Starter Strip Plus shingle helps save time by eliminating the need for cutting shingle tabs to create a starter row. It's a component of the Owens Corning® Total Protection Roofing System®A.



1. Starter Strip Plus is packaged two pieces per shingle, 16 shingles per bundle, 105 lineal feet.



2. Perforation down the center allows for easy separation.
3. Once apart, the Starter Strip Plus shingles should be aligned next to one another with the sealant toward the eave.

Starter Strip Plus shingle advantages:

Speeds installation and helps improve safety. Starter Strip Plus shingle eliminates the need to cut off tabs or headlap.

Clean look. Starter Strip Plus shingle provides a machine-cut straight edge at the eave and along the rake.

Saves labor. It's easy for a single person to position Starter Strip shingle on the roof.

Compatibility. Extra-wide starter can be used with most shingles that have an exposure of

up to 6" (per Application Instructions on the reverse side).

Improves job quality. Puts the sealant appropriately at the eaves.

Cost savings. There's no need to cut down field shingles to use as a starter strip.

Exceptional bonding strength. Continuous sealant ensures an effective seal between the starter and the first course of shingles.

Convenient. One (1) bundle provides 1 square of material (105 lineal feet of actual coverage).

Application Instructions

Owens Corning® Starter Strip Plus can be used with any shingle that has an exposure of up to 6". Starter Strip shingles cannot be used with Owens Corning® Berkshire®, Woodmoor® or Woodcrest® shingles.

Installation of Starter Strip Plus shingle

Starter Strip Plus shingle is designed to be broken into two pieces, and each piece has its own sealant strip. When separated, each starter shingle is 7¾" x 39⅝", and each bundle will cover approximately 105 lineal feet. See Fig. 1.

This starter can be used with shingles that have an exposure of no more than 6"; if the exposure is greater than 6", a full starter (15½" x 39⅝") would be required. See Fig. 1.

1. Start first Starter Strip Plus shingle with 6" removed from the rake edge and flush with the drip edge. Starter Strip Plus shingle can extend no greater than ¾" beyond the edge of the eave. Use 5 fasteners placed 2" to 3" from the edge of the eave. See Fig. 2.
2. During application, the installer must ensure that when the starter is applied, the overlaying shingles' end joints do not line up with the starter end joints. End joints must be a minimum of 4" from the overlaying shingle.
3. When the starter is used with 3-tab shingles, the installer must ensure that nails in the starter are not exposed between the cutouts of the overlaying shingle. Each starter shingle should be

cut to match the length of the 3-tab shingle being installed. Otherwise, the 6" offset will not match with shingles. Offsets are required to be a minimum of 4".

- When installing Owens Corning® Oakridge®/TruDefinition® Oakridge® shingles for maximum wind warranty, Starter Strip Plus shingles are required along both the eave and rake edge.

Fig. 1 Starter Strip Plus Shingle

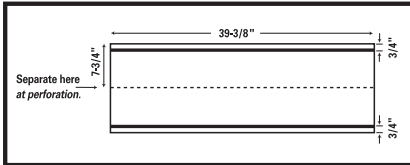
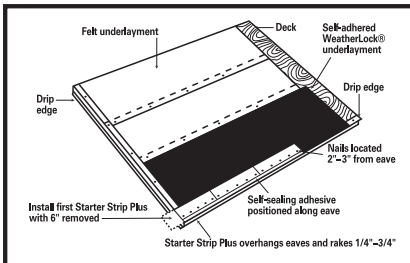

Fig. 2 Starter Strip Plus Shingle Application



Product Specifications

Size	15½" x 39 ³ / ₈ " (394 mm x 1000 mm)
Piece Size	7¾" x 39 ³ / ₈ " (197 mm x 1000 mm)
Shingles per Bundle	16
Pieces per Bundle	32 (7¾" x 39 ³ / ₈ " [197 mm x 1000 mm])
Lineal Feet per Bundle	Approximately 105 (32.0 m)

Applicable Standards and Codes

ASTM D3462
ASTM D3161 (Class F Wind Resistance)
ASTM E108/UL 790 (Class A Fire Resistance)*
CSA A123.5**
Florida Product Approval (FL10674)
Miami-Dade County Product Approval (09-0915.12)†
UL ER2453-01

Caution

Roof surface may be slippery: Especially when wet or icy. Use a fall protection system when installing. Wear rubber-soled shoes. Walk with care.

Falling hazard: Secure area below work and materials on roof. Wear a hard hat.

Notice

It is important that attic space be properly ventilated to maintain product performance and to prevent damage from moisture condensation and excessively high attic temperatures. In this regard, FHA and National Building Code Minimum Property Standards must be met.

WOODSTART® STARTER SHINGLE

For the use of Woodmoor/Woodcrest Shingles.

Precautionary Note:

The manufacturer will not be responsible for problems resulting from any deviation from the recommended application instructions and the following precautions:

CAUTION: Due to the aggressive nature of our shingle sealant strip, please note the following: To avoid shingles sticking in hot sun, do not have the sealant strip make contact with various objects on the roof, until you are ready to nail the shingle in place.

Roof Top Loading: Lay shingle bundles flat. Do not bend over the ridge.

Roof Deck: • 6" Minimum roof deck boards • Minimum $\frac{3}{8}$ " plywood • Minimum $\frac{7}{16}$ " OSB
Regardless of deck type used, the roofing installer must:

1. Install the deck material in strict compliance with the deck manufacturer's instructions.
2. Prevent the deck from getting wet before, during and after installation.

Ventilation: Must meet or exceed FHA Minimum Property Standards.

Handling: Use extra care in handling shingles when the temperature is below 40°F.

Storage: Store in a covered ventilated area at a maximum temperature of 110° F. Protect shingles from weather when stored at the job site. Do not store near steam pipes, radiators, etc.

Nails must be corrosion-resistant, 11- or 12-gauge, with heads at least $\frac{3}{8}$ " in diameter.

All Fasteners must penetrate at least $\frac{3}{4}$ " into the wood deck or completely through plywood sheathing.

Specialty Eave Flashing: WeatherLock® underlayment or equivalent eave and flashing membrane applied to a point at least 24" beyond interior wall line. See Fig. 1.

Figure 1
Specialty Eave Flashing

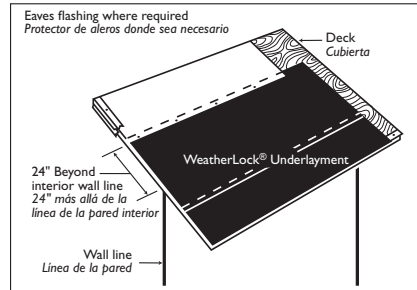

Underlayment:

Standard slope (4" in 12" or more)
Application of underlayment, metal drip edges, and ice dam protection. See Fig. 2.

Figure 2
Underlayment Standard Slope

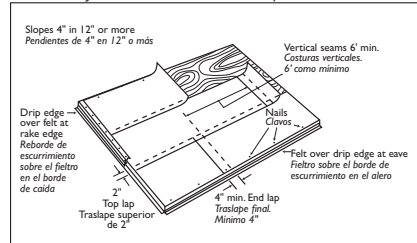

Low slope (2" in 12" to less than 4" in 12")
Application of underlayment and metal drip edges. See Fig 2A.

Figure 2A
Underlayment Low Slope

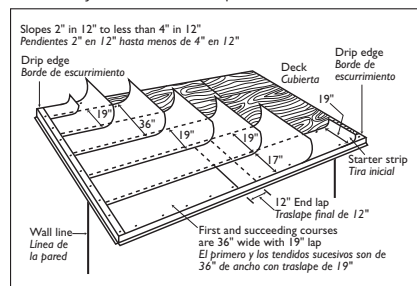

Fastener Placement: See Fig. 3.

Figure 3
Nail Pattern

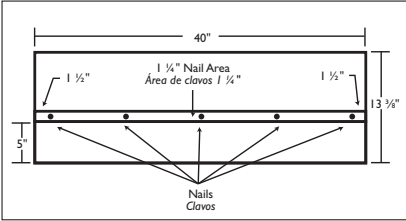

Starter Course:

Left Rake Application: Cut 35" off from the first bottom starter piece. Fasten the remaining 5" x 13 3/8" to the deck as shown in Fig. 4, followed by a full 13 3/8" x 40" starter piece to the deck with 5 fasteners as shown.

Figure 4
Left Rake Application

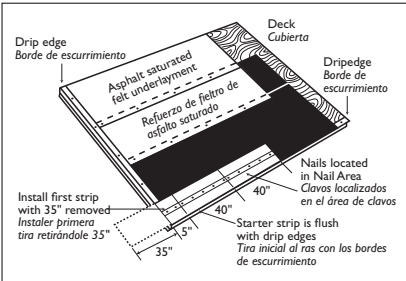

Right Rake Application: Cut 5" off from the first bottom starter piece. Fasten the remaining 35" x 13 3/8" to the deck as shown in Fig. 4A, followed by a full 13 3/8" x 40" starter piece to the deck with 5 fasteners as shown.

Figure 4A
Right Rake Application

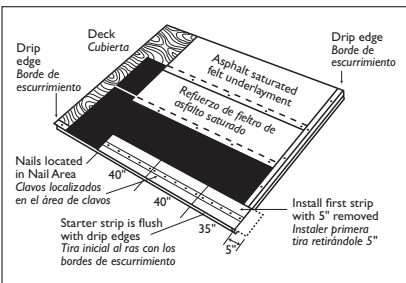

Note: Apply Woodcrest®/Woodmoor® shingles after WoodStart® Starter Shingles are installed. Apply Woodcrest®/Woodmoor® shingles per the application instructions printed on the shingle wrapper.

Made in U.S.A.

DURARIDGE® HIP & RIDGE SHINGLES

Before You Begin

Complete shingle application on roof deck before applying hip and ridge shingles. Hip shingles must be applied before applying ridge shingles. All hip and ridge shingles are applied with an 8 inch exposure. Note: If a new roof is being applied over an existing roof, remove the old hip and ridge shingles to obtain a level application.

Handling

Use extra care in handling shingles when the temperature is below 40°F. In cold weather, it is recommended to warm DURARIDGE® shingles before installing.

Fastener Requirement

Use galvanized steel, stainless steel, or aluminum nails minimum 12 gauge shank with $\frac{3}{8}$ " diameter head. Owens Corning Roofing recommends that fasteners comply with ASTM F 1667. Check local building codes. **All Fasteners** must penetrate at least $\frac{3}{4}$ " into the wood deck or completely through sheathing.

Note: Owens Corning Roofing recommends the use of nails as the preferred method of attaching shingles to wood decking or other nailable surface.

Installing

Begin hip application at the eave working toward the ridge.

1. Begin ridge application opposite the prevailing wind direction. (Fig. A)

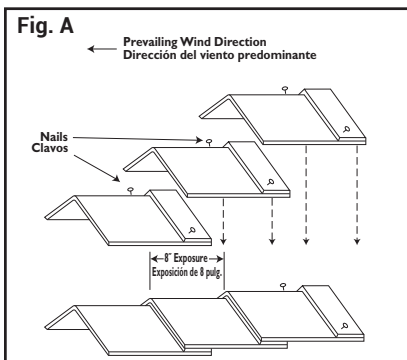

2. Arrange DURARIDGE® Hip & Ridge shingles along the center line so that both halves of the laminated piece fall on opposite sides of the hip or ridge. (Fig. B)

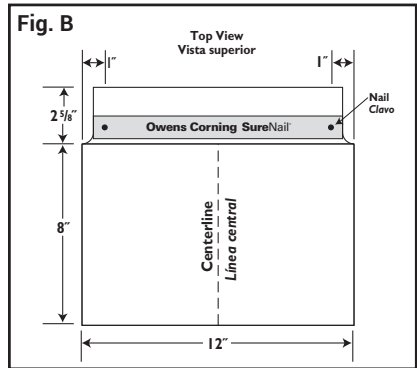

3. Begin application by creating a starting piece using the laminated piece with the 8 inch exposed portion of the shingle removed. Fasten starter piece with one nail on each side 1 inch in from the side edge starting from the fixed side edge placed into the SureNail® Technology fastening area.
4. Continue to fasten each full shingle through the top laminated piece with one nail on each side placed 9 inches back from the exposed end and 1 inch in from the side edge starting from the fixed edge of each shingle. Note: Fasteners must be placed into the SureNail® Technology fastening area. (Fig. B)
5. Apply remaining hip and ridge shingles in the same manner with 8 inch exposure.
6. When finishing the ridge, leave no laminated portion of the last hip and ridge shingle exposed. One option is to use the 8 inch exposure portion of a hip and ridge shingle, cutting a piece the appropriate length to extend over the laminated portion of the shingle to the end of the ridge.
7. Fasten final piece with two nails, each 1 inch in from each side edge and 1 inch in from the end of the ridge. Cover

exposed fasteners with asphalt roof cement. Asphalt roof cement must meet ASTM D4586 Type I or Type II (Asbestos Free). Note: Please be aware that excessive amounts of asphalt roof cement could blister the shingle.

Product Specifications

Size	12 inches x 10 ¾" (305 mm x 273 mm)
Pieces per Box	30
Application Exposure	8 inches (203 mm)
Lineal Coverage per Box	20 feet (6.49 m)

- STORE IN COVERED, VENTILATED AREA (UNDER 110°F/43°C)
- DO NOT STACK OVER EIGHT BUNDLES HIGH PER PALLET
- AVOID OUTSIDE STORAGE WHEN TEMPERATURES EXCEED 90°F/32°C
- DO NOT STORE IN DIRECT SUNLIGHT

FAILURE TO FOLLOW THESE STORAGE INSTRUCTIONS COULD CAUSE SHINGLES TO STICK TOGETHER.

Prepared roofing is exempt from OSHA Right-To-Know standard under its provision for articles (29 CFR 1910.1200-b-6-IV) as defined in 29 CFR 1910.1200c

*Limited Lifetime Warranty

This product carries a limited lifetime warranty (for as long as you own your home). You may obtain a copy of this roofing warranty by visiting our website at www.owenscorning.com or call 1-800-GET-PINK® (1-800-438-7465)

Owens Corning Roofing and Asphalt, LLC shall not be responsible for any damage, loss, cost, expense or liability relating to failure to follow these instructions. Failure to follow these installation instructions may affect Owens Corning Roofing and Asphalt, LLC's obligations under this product's limited warranty.

10-YEAR ALGAE-RESISTANCE LIMITED WARRANTY**

**Tropic zones outside of the USA and Canada have a reduced algae resistance limited warranty. See international warranty for more details.

RIZERIDGE® HIP & RIDGE SHINGLES

Precautionary Notes

Owens Corning® RIZERidge® Hip and Ridge Shingles are packaged 22 shingles per bundle with 3 perforated hip and ridge pieces per shingle.

Fastener requirements. Use galvanized steel, stainless steel, or aluminum nails minimum 12 gauge shank with $\frac{3}{8}$ " diameter head with a length long enough to penetrate through the roofing material a minimum of $\frac{3}{4}$ " into roofing sheathing. Where the roof sheathing is less than $\frac{3}{4}$ " thick, the fasteners shall penetrate through the sheathing. Fasteners shall comply with ASTM F1667.

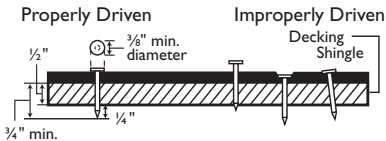

Preparation of Hip and Ridge

Separate hip and ridge at the perforation, each piece should measure 12" x 12", there are 3 pieces per shingle (See Fig. 1)

- 1. Starter course for a ridge**
 Fold the upper portion of the individual hip and ridge shingle. (See Fig. 2) Once folded cut the 6" exposed region off from the folded stack. Use this folded stack section as the starter for the first hip and ridge shingle (See Fig. 3)
- 2. Starter** should be installed opposite the prevailing wind for gable end homes. For hip roofs start at the eaves edge.
- Place the shingle edge of the hip and ridge on top of the starter and nail in place into the double folded area of the shingle.
- 2 Nail Standard Application**
 The nails should be placed 7" from the bottom edge and 1" from each side edge (See Fig. 4)
- 4 Nail 130-MPH Application for Duration® Series Shingles with SureNail® Technology**
 Four nails and hand sealing must be used to maintain the 130-MPH wind warranty.* The nails should be placed 7" from the bottom edge and 1 and 2" in from each side edge. (See Fig. 4A)

Apply a $\frac{1}{4}$ " wide by 2" long bead of elastomeric sealant that meets ASTM C-920 approximately 1 $\frac{1}{2}$ " in from side edge. (See Fig. 4A)

- Place and align another folded shingle onto the secured shingle and repeat across the ridge. (See Fig. 5)
- * See actual warranty for complete details, limitations and requirements.

Figure 1 Hip & Ridge Shingle

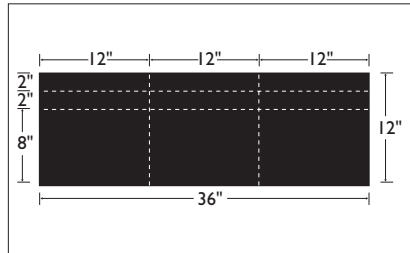

Figure 2 Folded Hip & Ridge Shingle

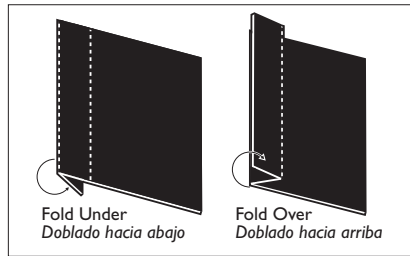

Figure 3 Folded Ridge Starter Shingle

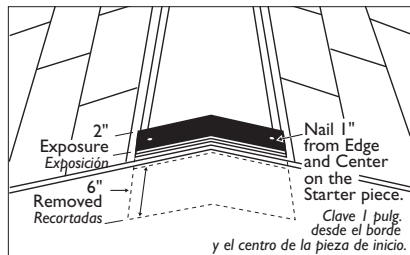

Figure 4 Two Nail Standard Application

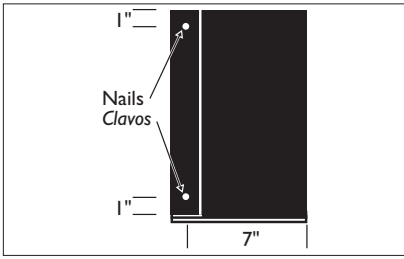

Figure 4A Four Nail 130-mph Application

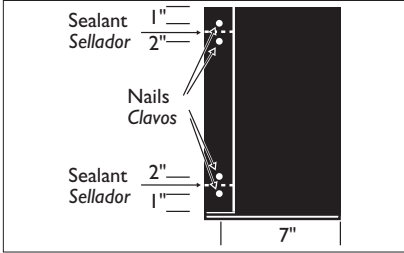
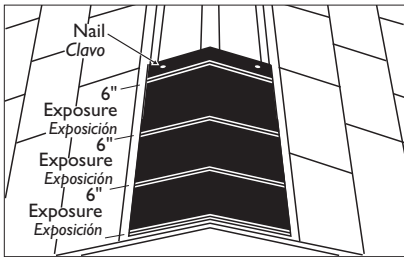

Figure 5 Succeeding Courses



DECORIDGE® HIP & RIDGE SHINGLES

Complete shingle application on roof deck before applying hip and ridge shingles. Hip shingles must be applied before applying ridge shingles. All hip and ridge shingles are applied with an 8" exposure.

Note: If a new roof is being applied over an existing roof, remove the old hip and ridge shingles to obtain a level application.

Use nails only when installing this product. Nails must be corrosion resistant, 11 or 12 gauge, with heads at least $\frac{3}{8}$ " in diameter.

Standard Fastening Pattern: One nail should be placed 8½" back from the exposed end and ½" in for each side edge. (Fig. 1)

Application

1. Begin hip application at the eave working toward the ridge.
- 1a. Begin ridge application opposite the prevailing wind direction. (Fig. 2)
2. Cut first hip and ridge 8" back from the exposed end. Use the top portion of the shingle with sealant as the "starter" hip or ridge shingle. (Fig. 2)
3. Install this "starter" shingle positioned at the leading edge of the hip or ridge. Follow Standard Fastening Pattern in Fig. 1.
4. Completely cover "starter" shingle with the 8" exposed portion of the next hip and ridge shingle. (Fig. 3)
5. Fasten each shingle through the dimensional fold, following the Standard Fastening Pattern in Fig. 1. All nails must be covered by succeeding shingles. Apply remaining hip and ridge shingles in the same manner.
6. Cut final ridge shingle from the 8" exposed portion of a hip and ridge shingle. Cut piece an appropriate length to the end of the ridge. (Fig. 4)
7. Standard fastening pattern: Fasten final piece with two nails, ½" in from each side edge and 1" in from the end of the ridge. Cover nail with roof cement. (Fig. 4)

Figure 1
8" or 10" width

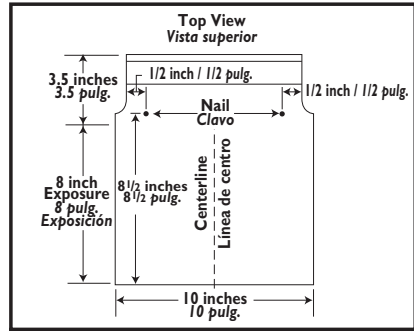

Figure 2

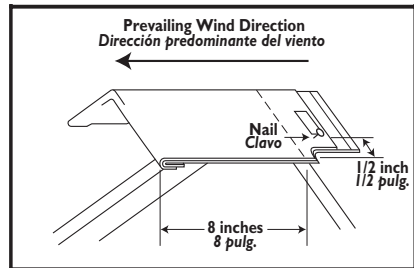

Figure 3

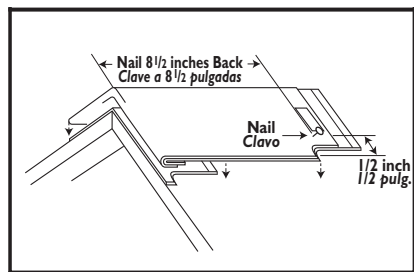
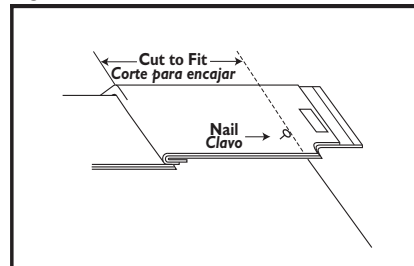

Figure 4



PROEDGE® HIP & RIDGE SHINGLES

Complete shingle application on roof deck before applying hip and ridge shingles. *Hip shingles must be applied before ridge shingles.* **Note:** If a new roof is being applied over an existing roof, remove the old hip and ridge shingles to obtain a level application. Each shingle is perforated for separation into three Hip & Ridge shingles.

Precautionary Notes: The manufacturer will not be responsible for problems resulting from any deviation from the recommended application instructions and the following precautions.

- (A) **Handling:** Use extra care in handling shingles when the temperature is below 40°F (5°C). DO NOT drop bundles. Shingles can be broken easily in cold weather or their edges damaged in hot weather. DO NOT attempt to separate shingles by "breaking" them over another object such as a ridge.
- (B) **Fastener requirement:** Use galvanized steel, stainless steel, or aluminum nails minimum 12 gauge shank with 3/8" diameter head. Owens Corning recommends that fasteners comply with ASTM F 1667. Check local building codes. All fasteners must penetrate at least 3/4" into the wood deck or completely through plywood or OSB sheathing.
- (C) **Fastening:** Drive all fasteners until they are flush with the surface of the shingle. Special care must be taken when using pneumatic nail guns. Nails are to be driven straight so the entire head is flush against the shingle but does not cut the shingle surface. An improperly adjusted pneumatic gun can result in raised fasteners causing sealing failure, raised tabs, leaks, or blow-off. Place fasteners 7 1/2" from the butt edge of the shingle. Do not apply fasteners in the sealant strip.
- (D) **Storage:** Store in a covered, ventilated area at a maximum temperature of 110°F (43°C). Stack in a flat fashion (maximum of 24 bundles high). Protect shingles from weather when stored at the job site. Do not store near steam pipes, radiators, etc.

(E) All exposed material must be rated **Class A by Underwriters Laboratories**, to maintain a Class A system.

Hip & Ridge Application

1. Apply Hip & Ridge as shown, bending them over the hip or ridge lengthwise.
2. Apply ridge after hips have been applied, beginning on end of ridge opposite prevailing wind direction. See Fig. 1

Figure 1

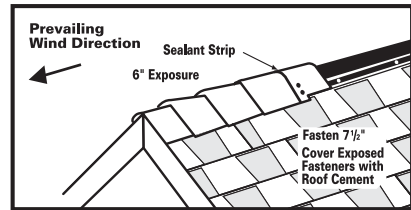

3. Apply shingles with 6" exposure.
4. Fasten each shingle with 2 fasteners on each side, 1 inch and 2 inches from the edge and 7 1/2 inch from the exposed end. See Fig. 2. **Do not place nails in sealant line.**

Figure 2

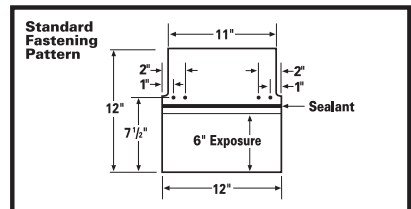

5. Apply remaining hip and ridge shingles in the same manner with a 6 inch exposure.
6. When finishing the ridge, leave no headlap portion of the last hip and ridge shingle exposed. One option is to use the 6 inch exposed portion of a hip and ridge shingle, cutting a piece the appropriate length to extend over the headlap portion of the shingle to the end of the ridge.
7. Fasten final piece with four nails, each 1 inch and 2 inches in from each side

edge and 1 inch in from the end of the ridge. Cover exposed fasteners with asphalt roof cement. Asphalt roof cement must meet ASTM D-4586 Type I or Type II (Asbestos Free).

Installing Double Hip & Ridge

Applying a double layer of shingles to hips or ridges is easy to do and creates a more aesthetically pleasing appearance. Simply install the shingles using the method described above, but fasten two shingles simultaneously – one on top of the other. Make sure fasteners are long enough to penetrate through both layers of shingle and completely through the roof deck. See Fig. 3

Figure 3

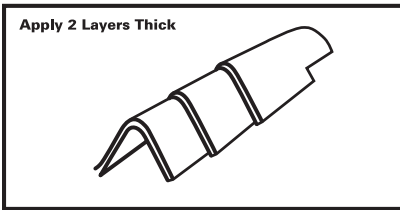

CAUTION: DO NOT MIX MATERIAL BEARING DIFFERENT LOT NUMBERS, REFER TO THE LOT NUMBERS LOCATED ON THE SIDE OF THE BUNDLE

PROEDGE STORM® AR HIP & RIDGE SHINGLES WITH WEATHERGUARD® TECHNOLOGY

Owens Corning® ProEdge STORM® Hip & Ridge Shingles are designed to complement TruDefinition® Duration STORM® Impact Resistant Shingles.

Note: Off ridge vents should be used. Use of shingle-over ridge vent will affect the impact resistance classification.

Complete shingle application on roof deck before applying hip and ridge shingles. *Hip shingles must be applied before ridge shingles.* If a new roof is being applied over an existing roof, remove the old hip and ridge shingles to obtain a level application. Each shingle is perforated for separation into three Hip & Ridge shingles.

High Wind: To maintain the 130-MPH wind warranty you must nail each hip and ridge shingle with 4 nails and hand seal each shingle using the High Wind Zone application. See Fig. 3

Precautionary Notes

The manufacturer will not be responsible for problems resulting from any deviation from the recommended application instructions and the following precautions.

- (A) **Handling:** Use extra care in handling shingles when the temperature is below 40°F (5°C). DO NOT drop bundles. Shingles can be broken easily in cold weather or their edges damaged in hot weather. DO NOT attempt to separate shingles by “breaking” them over another object such as a ridge.
- (B) **Fastener requirement:** Use galvanized steel, stainless steel, or aluminum nails minimum 12 gauge shank with $\frac{3}{8}$ inch diameter head. Owens Corning recommends that fasteners comply with ASTM F1667. Check local building codes. All fasteners must penetrate at least $\frac{3}{4}$ inch into the wood deck or completely through sheathing.
- (C) **Fastening:** Drive all fasteners until they are flush with the surface of the shingle. Special care must be taken when using pneumatic nail guns. Nails are to be driven straight so the entire head is flush against the shingle but does not cut the shingle surface. An

improperly adjusted pneumatic gun can result in raised fasteners causing sealing failure, raised tabs, leaks, or blow-off. Place fasteners $\frac{6}{16}$ inch from the butt edge of the shingle and above the sealant strip (see Fig. 1) Do not apply fasteners in the sealant strip.

- (D) **Storage:** Store in a covered, ventilated area at a maximum temperature of 110°F (43°C). Stack in a flat fashion (maximum of 24 bundles high). Protect shingles from weather when stored at the job site. Do not store near steam pipes, radiators, etc.
- (E) **All exposed material must be rated Class A by Underwriters Laboratories, to maintain a Class A system.**

Hip & Ridge Application

1. Apply Hip & Ridge as shown, bending them over the hip or ridge lengthwise. See Fig. 1
2. Apply ridge after hips have been applied, beginning on end of ridge opposite prevailing wind direction. See Fig. 1
3. Apply shingles with a 6 inch exposure.
4. Fasten each shingle with 2 fasteners on each side, 1 inch and 2 inches from the edge and $\frac{6}{16}$ inch from the exposed end. See Fig. 2

FOR 130-MPH WIND WARRANTY

Apply a $\frac{1}{4}$ inch wide bead of Elastomeric Sealant that meets ASTM C-920 approximately 1 inch in from edge and approximately 5 inches long to each side of the hip and ridge shingle. See Fig. 3

5. Apply remaining hip and ridge shingles in the same manner with a 6 inch exposure.
6. When finishing the ridge, leave no headlap portion of the last hip and ridge shingle exposed. One option is to use the 6 inch exposed portion of a hip and ridge shingle, cutting a piece the appropriate length to extend over the headlap portion of the shingle to the end of the ridge.

- Fasten final piece with four nails, each 1 inch and 2 inches in from each side edge and 1 inch in from the end of the ridge. Cover exposed fasteners with asphalt roof cement. Asphalt roof cement must meet ASTM D-4586 Type I or Type II (Asbestos Free).

CAUTION: DO NOT MIX MATERIAL BEARING DIFFERENT LOT NUMBERS, REFER TO THE LOT NUMBERS LOCATED ON THE SIDE OF THE BUNDLE

PROEDGE STORM® HIP & RIDGE

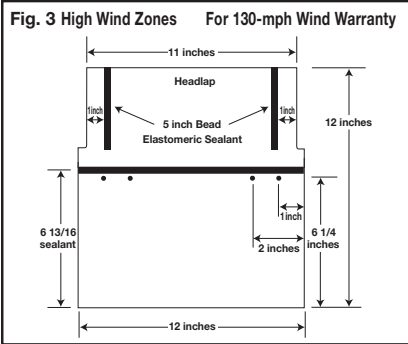
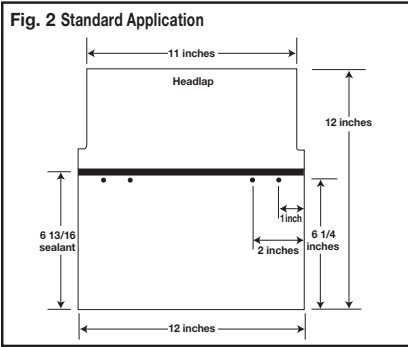
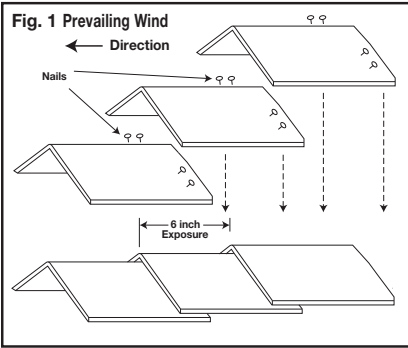

PROEDGE FLEX™ SHINGLES

CAUTION: DO NOT MIX MATERIAL BEARING DIFFERENT LOT NUMBERS, REFER TO THE LOT NUMBERS LOCATED ON THE SIDE OF THE BUNDLE.

Note: Off ridge vents should be used. Use of shingle-over ridge vent may affect the impact resistance classification.

Complete shingle application on roof deck before applying hip and ridge shingles. Hip shingles must be applied before ridge shingles. Note: If a new roof is being applied over an existing roof, remove the old hip and ridge shingles to obtain a level application. Each shingle is perforated for separation into three Hip & Ridge shingles.

Precautionary Note:

The manufacturer will not be responsible for problems resulting from any deviation from the recommended application instructions and the following precautions:

Roof Top Loading: Lay shingle bundles flat. Do not bend over the ridge.

Roof Deck: • 6 inch minimum roof deck boards • Minimum $\frac{3}{8}$ inch plywood • Minimum $\frac{7}{16}$ inch OSB

Regardless of deck type used, the roofing installer must:

1. Install the deck material in strict compliance with the deck manufacturer's instructions.
2. Prevent the deck from getting wet before, during and after installation.

Ventilation: Check local building codes.

Handling: Use extra care in handling shingles when the temperature is below 40°F.

Storage: Store in a covered ventilated area at a maximum temperature of 110°F. Bundles should be stacked flat. Protect shingles from weather when stored at the job site. Do not store near steam pipes, radiators, etc.

Fastener requirement: Use galvanized steel, stainless steel, or aluminum nails minimum 12 gauge shank with $\frac{3}{8}$ inch diameter head. Owens Corning recommends that fasteners

comply with ASTM F1667. Must comply with local building codes.

All Fasteners must penetrate at least $\frac{3}{4}$ inch into the wood deck or completely through sheathing.

Notice: Owens Corning recommends the use of nails as the preferred method of attaching shingles to wood decking or other nailable surface.

Hip & Ridge Application

1. Apply Hip & Ridge as shown, bending them over the hip or ridge lengthwise.
2. Apply ridge after hips have been applied, beginning on end of ridge opposite prevailing wind direction. See Fig. 1.
3. Apply shingles with 6 inches exposure.
4. Fasten each shingle with 2 fasteners on each side, 1 inch and 2 inches from the edge and $6\frac{1}{4}$ inch from the exposed end. See Fig. 2.
5. Apply remaining hip and ridge shingles in the same manner with a 6 inch exposure.
6. When finishing the ridge, leave no headlap portion of the last hip and ridge shingle exposed. One option is to use the 6 inch exposed portion of a hip and ridge shingle, cutting a piece the appropriate length to extend over the headlap portion of the shingle to the end of the ridge.
7. Fasten final piece with four nails, each 1 inch and 2 inches in from each side edge and 1 inch in from the end of the ridge. Cover exposed fasteners with asphalt roof cement.

Asphalt roof cement must meet ASTM D4586 Type I or Type II (Asbestos Free).

Note: Please be aware that excessive amounts of asphalt roof cement could blister the shingle.

Installing Double Hip & Ridge

Applying a double layer of shingles to hips or ridges is easy to do and creates a more aesthetically pleasing appearance. Simply install the shingles using the method

described above, but fasten two shingles simultaneously — one on top of the other. Make sure fasteners are long enough to penetrate through both layers of shingle and completely through the roof deck. See Fig. 3.

Figure 1

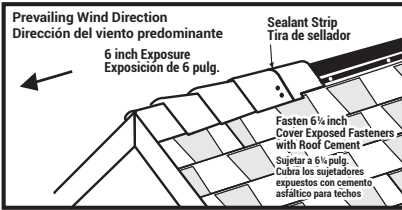

Figure 2

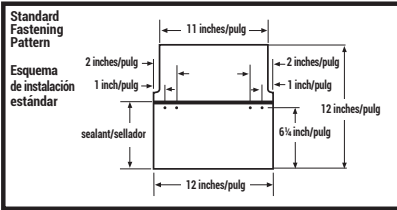
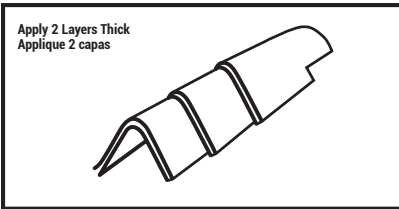

Figure 3



BERKSHIRE® HIP & RIDGE SHINGLES

BERKSHIRE® AR HIP & RIDGE SHINGLES with Sealant

Application Instructions for Berkshire® Hip & Ridge Shingle Cap

For Miami-Dade County approval, the four-nail fastening pattern must be used.

Before You Begin

Complete shingle application on roof deck before applying hip and ridge shingles. Hip shingles must be applied before applying ridge shingles. All hip and ridge shingles are applied with an 8" exposure. Note: If a new roof is being applied over an existing roof, remove the old hip and ridge shingles to obtain a level application.

Handling

Use extra care in handling shingles when the outdoor temperature is below 40°F.

Fastening

Use nails only when installing this product. Nails must be corrosion resistant, 11- or 12 gauge, with heads at least $\frac{3}{8}$ " in diameter. Owens Corning recommends that fasteners comply with ASTM F1667. For the **Standard Fastening Pattern**, nails should be placed 9" back from the exposed end and 1" in from the side edge. (Fig. 2) For the **Four-Nail Fastening Pattern**, apply two nails on each side 9" from the exposed end, and 1" and 2" from the side edge. (Fig. B) All fasteners must penetrate at least $\frac{3}{4}$ " into wood deck or completely through plywood sheathing. Cover exposed fasteners on last hip and ridge shingle with asphalt roof cement. Asphalt roof cement must meet ASTM D 4586 Type I or II (Asbestos Free).

Installing

Begin **hip** application at the eave working toward the ridge.

1. Begin **ridge** application opposite the prevailing wind direction. (Fig. 1/Fig. A)
2. Arrange Berkshire® Hip & Ridge shingles along the center line so that both halves of the laminated piece fall on opposite sides of the hip or ridge. (Fig. 2/Fig. B)
3. For the **Standard Fastening Pattern**, fasten each shingle through the top

laminated piece with one nail on each side, placed 10" back from the exposed end and 1" in from the side edge. (Fig. 2) For the **Four-Nail Fastening Pattern**, fasten each shingle through the top laminated piece with two nails on each side, placed 9" back from the exposed end and 1" and 2" in from the side edge. (Fig. B)

4. Apply remaining hip and ridge shingles in the same manner with 8" exposure.
5. When finishing the ridge, leave no laminated portion of the last hip and ridge shingle exposed. One option is to use the 8" exposed portion of a hip and ridge shingle, cutting a piece the appropriate length to extend over the laminated portion of the shingle to the end of the ridge.
6. For the **Standard Fastening Pattern**, fasten final piece with two nails, each 1" in from the side edge and 1" in from the end of the ridge. For the **Four-Nail Fastening Pattern**, fasten final piece with four nails, each 1" and 2" in from each side edge and 1" in from the end of the ridge. For **both fastening patterns**, cover exposed fasteners with asphalt roof cement.

Standard Nail Fastening Pattern

Figure 1

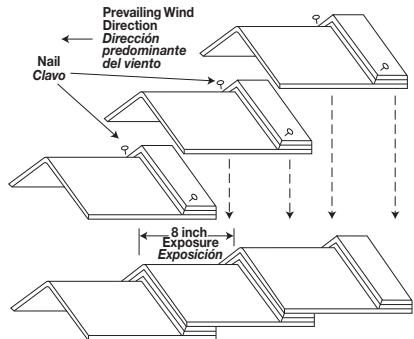
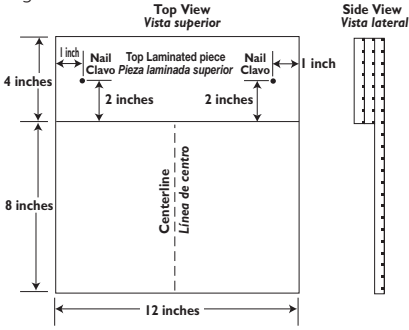
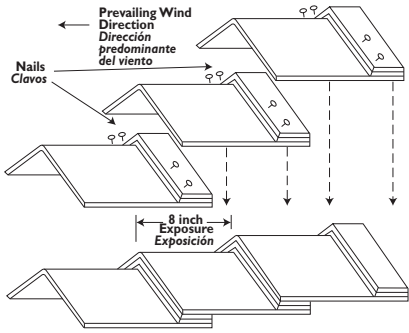

Figure 2



Four-Nail Fastening Pattern
 Figure A – Berkshire® Hip & Ridge Shingle Application



BERKSHIRE® HIP & RIDGE

Figure B – Hip & Ridge Shingle Fastening

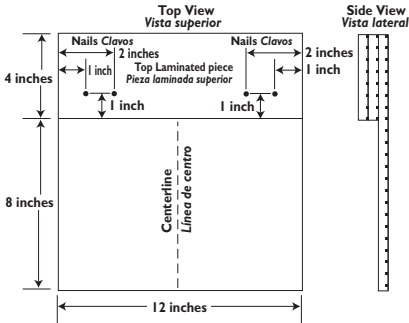

WEATHERGUARD® HP HIP & RIDGE SHINGLES

CAUTION: DO NOT MIX MATERIAL BEARING DIFFERENT LOT NUMBERS; REFER TO THE LOT NUMBERS LOCATED ON THE SIDE OF THE BUNDLE.

Owens Corning® WeatherGuard® HP Hip & Ridge shingles are designed to complement WeatherGuard® HP shingles.

NOTE: Use of shingle-over ridge vent will affect the impact resistance classification. Before You Begin

Complete shingle application on roof deck before applying hip and ridge shingles. Hip shingles must be applied before applying ridge shingles. All hip and ridge shingles are applied with a 5" exposure. **To maintain the 130-MPH wind warranty, you must nail each hip and ridge shingle with 4 nails and hand seal each shingle using the High Wind Zone application. See Fig. B.**

Failure to hand seal will reduce the wind warranty to 110 MPH for the hip and ridge shingle. See Fig. C.

Fastening

Use nails only when installing this product. Nails must be corrosion-resistant, 11- or 12-gauge, with heads at least $\frac{3}{8}$ " in diameter.

1. Separate each piece of WeatherGuard® Hip & Ridge shingle into three individual ridge cap shingle pieces at perforations.
2. All fasteners must penetrate at least $\frac{3}{4}$ " into wood deck or completely through plywood sheathing. Cover exposed fasteners on last hip and ridge shingle with asphalt cement. Roof cement must meet ASTM D-4586 Type I or II (Asbestos Free).

For High Wind Zones

Apply a $\frac{1}{4}$ " wide bead of elastomeric sealant that meets ASTM C920 approximately 1" in from edge and approximately 5" long to each side of the hip and ridge shingle. See Fig. B.

Installing

Begin hip application at the eave, working toward the ridge.

1. Begin ridge application opposite the prevailing wind direction. See Fig. A.

2. Arrange WeatherGuard® HP Hip & Ridge shingles along the centerline so that both halves fall on opposite sides of the hip or ridge.
3. Fasten each shingle through the top with two nails on each side, placed 6" back from the exposed end and 1" and 2" in from the side edge. See Fig. B.
4. Apply remaining hip and ridge shingles in the same manner with 5" exposure.
5. When finishing the ridge, leave no headlap portion of the last hip and ridge shingle exposed. One option is to use the 5" exposed portion of a hip and ridge shingle, cutting a piece the appropriate length to extend over the headlap portion of the shingle to the end of the ridge.
6. Fasten final piece with four nails, each 1" and 2" in from each side edge and 1" in from the end of the ridge. Cover exposed fasteners with asphalt roof cement.

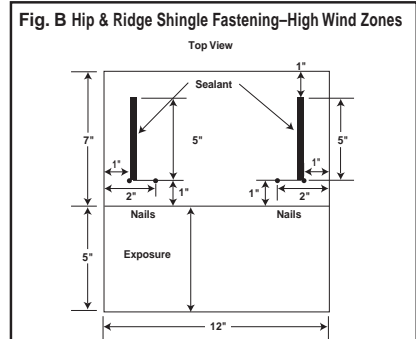
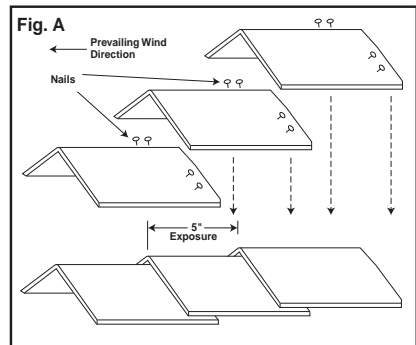

WEATHERGUARD® HP HIP & RIDGE

Fig. C Hip & Ridge Shingle Fastening

Top View

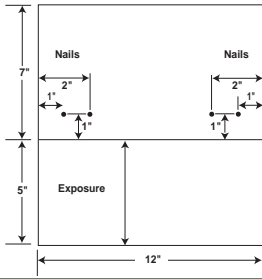

Caution: Roof surface may be slippery, especially when wet or icy. Use a fall protection system when installing. Wear rubber-soled shoes. Walk with care.

Falling Hazard: Secure area below work and materials on roof.

Unsecured materials may slide on roof. Place on level plane or secure to prevent sliding. Wear a hard hat.

Caution: Safety glasses should always be worn when cutting the roof with a power tool.

Wear gloves when installing to avoid cuts and abrasions.

VENTSURE® 4' STRIP HEAT & MOISTURE RIDGE VENTS

VentSure® 4' Strip Ridge Vents are designed for roofs with slopes of 3/12 to 16/12 pitches.

Intake at the eave vents should be equal to or exceed that of the ridge vent being installed. VentSure ridge vent is designed for residential applications.

IMPORTANT NOTES:

1. On architectural shingles, roofing cement should be used where the roof vent lower edge meets the laminate shingle to prevent wind-driven rain or snow to blow under the ridge vent.
2. Before applying vent to architectural shingles on new construction, leave felt long at ridge and fold back under vent or caulk between low areas of shingle and flange of vent, making sure you don't plug holes.
3. See instructions for cutting slot.
4. For structures with different ridge heights, be sure to vent the higher ridge; it is also acceptable to vent lower ridges with dormers.
5. For best appearance, run VentSure ridge vent from end to end to give the roof a more attractive appearance.
6. For truss rafters, cut a 1" slot on each side of the ridge starting a minimum of 6" from the rake edge of the roof. For roofs with a center ridge board, cut a 1¾" slot on each side of the ridge starting a minimum of 6" from the rake edge of the roof. Combined width of slots and ridge board should not exceed 3½".

Installation Instructions

1. Using a chalk line, mark out 1" on both sides of the ridge as a guide for cutting a slot in the top of the ridge. See Fig. 1.

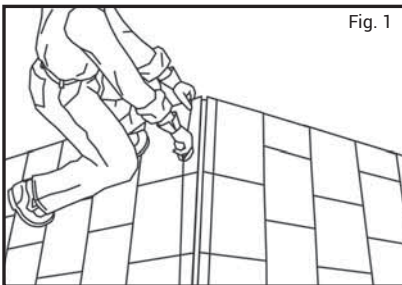

2. Cut slot using a circular saw with the blade set at a depth to cut through the wood sheathing only. See Fig. 2.

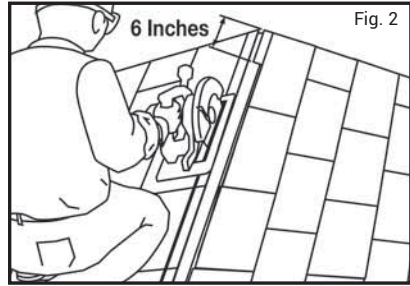

NOTE: Start the cut 6" from the edge of the roof. Remove the sheathing debris from slot.

3. Center the vent over the opening that has been cut in the ridge, ensuring the vent sits flat on the roof. Also ensure that the alignment tabs are facing the opposite direction you will be installing the next piece of ridge vent. See Fig. 3.



4. As you install the vents, ensure each vent is snapped together, then nail in place using the nail holes marked on each vent. See Fig. 4.



*Do not use Pneumatic nail guns to install hip and ridge shingles over VentSure® 4' strip.

5. Using a utility knife, cut the final piece to a length long enough so that it is flush with the edge of the roof. Connect making sure that the built-in end caps are exposed and nail in place. See Fig. 5.

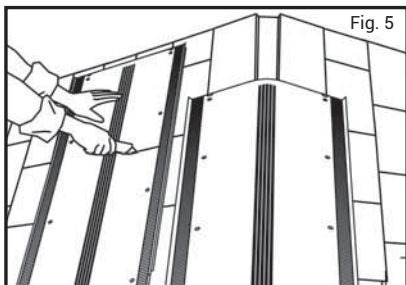

NOTE: In most cases, the final piece will not use the interlocking feature.

6. Nail hip and ridge shingle over the vent using nails long enough to meet the penetration requirements of the shingle manufacturer or use nails provided with the VentSure ridge vent. Do not use Pneumatic nail guns to install hip and ridge shingles over VentSure 4' strip. For a clean look, extend the hip and ridge shingle to cover the interlocking tabs or trim tabs off using a utility knife. See Fig. 6.

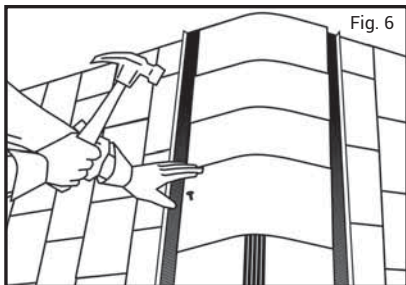

INSTRUCTIONS FOR CUTTING SLOTS

Hip and Gable Roofs

Cut slot 1" on both sides of ridge to within 6" of end wall or hip intersection. See Fig. 7.

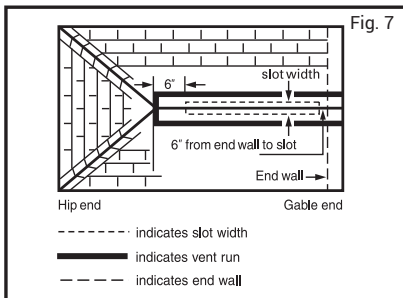

Chimneys

Cut slots 12" from chimney. Run ridge vent from end of roof to butt against chimney. See Fig. 8.

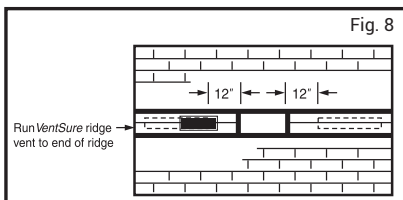

NOTE: Owens Corning's written warranty for this product shall not apply in any instance in which the product was not installed in accordance with the instructions contained herein. See actual warranty for additional warranty details.

LIMITED WARRANTY This product is covered by a Limited Warranty which is available by calling 1-800-GET-PINK® or visiting our Web site at www.owenscorning.com.

THAT WARRANTY CONSTITUTES OUR EXCLUSIVE WARRANTY, AND WE HEREBY DISCLAIM ALL OTHER WARRANTIES, WHETHER EXPRESSED OR IMPLIED, INCLUDING THE IMPLIED WARRANTIES OF MERCHANTABILITY AND FITNESS FOR A PARTICULAR PURPOSE. IN NO EVENT SHALL OWENS CORNING BE LIABLE TO CUSTOMER FOR INCIDENTAL, INDIRECT OR CONSEQUENTIAL DAMAGES.

WARNING ADVERTENCIA

Slippery surface, especially when wet or icy. Use a fall protection system when installing. Wear rubber-soled shoes. Walk with care.
 Área resbalosa, especialmente cuando está mojada o helada. Utilice un sistema de protección contra caídas cuando realice la instalación. Use zapatos de hule. Camine con cuidado.

WARNING ADVERTENCIA

Sharp edges. Wear gloves when working. Filos cortantes. Use guantes cuando esté trabajando.

WARNING ADVERTENCIA

Falling hazard. Secure area below work and materials on roof. Unsecured materials may slide on roof. Place on level plane or secure to prevent sliding. Wear a hardhat.
 Peligro de objetos que caen. Por favor asegure el área que se encuentra debajo de la zona de trabajo y amarre los materiales al techo. Los materiales que no estén sujetos pueden resbalarse del techo. Colóquelos en un lugar que no tenga pendiente, o sujételos para prevenir que se caeban. Use un casco resistente.

WARNING ADVERTENCIA

Caution: Safety glasses should always be worn when cutting the roof with a power tool. Precaución: Siempre deben utilizarse anteojos de seguridad al cortar el techo con sus herramientas eléctricas.

Product Specifications

VentSure® 4-Foot Strip

Model Name	Width	Color	Material Code	Short Code	NFVA	Shipping Information
4' Strip Heat and Moisture vent w/Nails	12"	Black	796301	VS4N	20 sq. in. per linear ft.	10 pcs/Ctn 12 Ctns/Pallet 48 Pallets/TL
4' Strip Heat and Moisture vent w/ Weather PROtector® moisture barrier	12"	Black	796337	VS4W	20 sq. in. per linear ft.	
4' Strip Heat and Moisture vent w/ Weather PROtector® moisture barrier	10"	Black	796396	VS4TW	18 sq. in. per linear ft.	
4' Strip Heat and Moisture vent w/ Weather PROtector® moisture barrier	8"	Black	796395	VS4EW	18 sq. in. per linear ft.	

VENTSURE® 4' STRIP RIDGE VENT

VENTSURE® 4' STRIP HEAT & MOISTURE RIDGE VENTS

with Weather PROtector® Moisture Barrier

VentSure® 4' Strip Ridge Vents are designed for roofs with slopes of 3/12 to 16/12 pitches.

Intake at the eave vents should be equal to or exceed that of the ridge vent being installed. *VentSure* ridge vents are designed for residential applications.

IMPORTANT NOTES:

1. On architectural shingles, roofing cement should be used where the roof vent lower edge meets the laminate shingle to prevent wind-driven rain or snow from blowing under the ridge vent.
2. Before applying vent to architectural shingles on new construction, leave felt long at ridge and fold back under vent or caulk between low areas of shingle and flange of vent, making sure you don't plug holes.
3. See instructions for cutting slot.
4. For structures with different ridge heights, be sure to vent the higher ridge; it is also acceptable to vent lower ridges with dormers.
5. For best appearance, run *VentSure*® ridge vent from end to end to give the roof a more attractive appearance.
6. For truss rafters, cut a 1¼" slot on each side of the ridge starting a minimum of 6" from the rake edge of the roof. For roofs with a center ridge board, cut a 1¼" slot on each side of the ridge starting a minimum of 6" from the rake edge of the roof. Combined width of slots and ridge board should not exceed 3½".

Installation Instructions

1. Using a chalk line, mark out 1¼" on both sides of the ridge as a guide for cutting a slot in the top of the ridge. See Fig. 1.

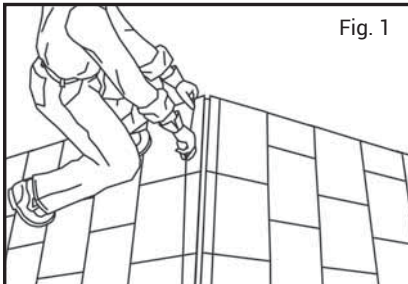

2. Cut slot using a circular saw with the blade set at a depth to cut through the wood sheathing only. See Fig. 2.

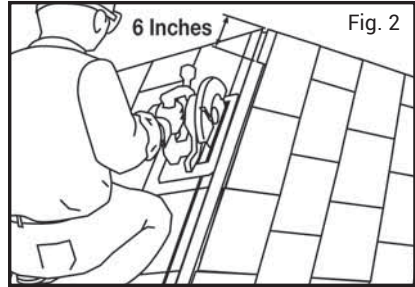

NOTE: Start the cut 6" from the edge of the roof. Remove the sheathing debris from slot.

3. Center the vent over the opening that has been cut in the ridge, ensuring the vent sits flat on the roof. Also ensure that the alignment tabs are facing the opposite direction you will be installing the next piece of ridge vent. See Fig. 3.



4. As you install the vents, ensure each vent is snapped together, then nail in place using the nail holes marked on each vent. See Fig. 4.

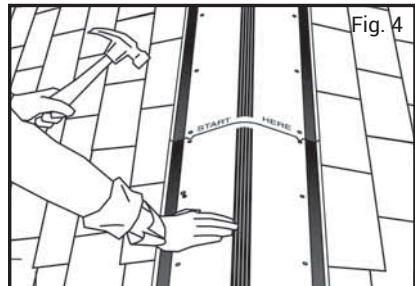

*Do not use Pneumatic nail guns to install hip and ridge shingles over VentSure® 4' strip.

5. Using a utility knife, cut the final piece to a length long enough so that it is flush with the edge of the roof. Connect making sure that the built-in end caps are exposed and nail in place. See Fig. 5.

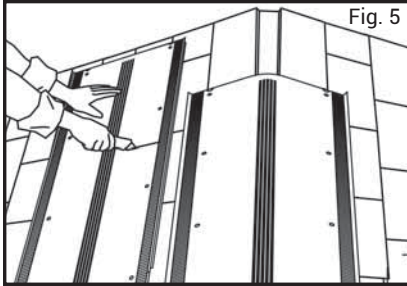

NOTE: In most cases, the final piece will not use the interlocking feature.

6. Nail hip and ridge shingle over the vent using nails long enough to meet the penetration requirements of the shingle manufacturer or use nails provided with the VentSure ridge vent. Do not use Pneumatic nail guns to install hip and ridge shingles over VentSure 4' strip. For a clean look, extend the hip and ridge shingle to cover the interlocking tabs or trim tabs off using a utility knife. See Fig. 6.

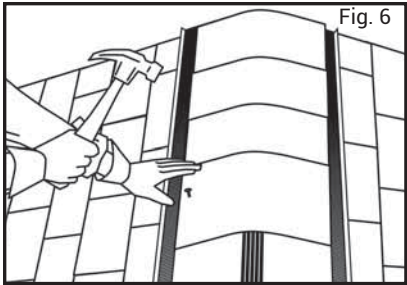

INSTRUCTIONS FOR CUTTING SLOTS

Hip and Gable Roofs

Cut slot 1 1/4" on both sides of ridge to within 6" of end wall or hip intersection. See Fig. 7.

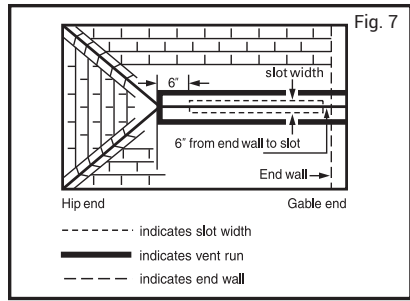

Chimneys

Cut slots 12" from chimney. Run ridge vent from end of roof to butt against chimney. See Fig. 8.

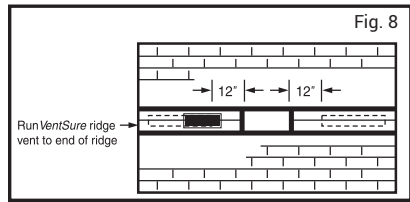

NOTE: The Owens Corning written warranty for this product shall not apply in any instance in which the product was not installed in accordance with the instructions contained herein. See actual warranty for additional warranty details.

LIMITED WARRANTY This product is covered by a Limited Warranty which is available by calling 1-800-GET-PINK® or visiting our Web site at www.owenscorning.com.

THAT WARRANTY CONSTITUTES OUR EXCLUSIVE WARRANTY, AND WE HEREBY DISCLAIM ALL OTHER WARRANTIES, WHETHER EXPRESSED OR IMPLIED, INCLUDING THE IMPLIED WARRANTIES OF MERCHANTABILITY AND FITNESS FOR A PARTICULAR PURPOSE. IN NO EVENT SHALL OWENS CORNING BE LIABLE TO CUSTOMER FOR INCIDENTAL, INDIRECT OR CONSEQUENTIAL DAMAGES.

WARNING ADVERTENCIA

Slippery surface, especially when wet or icy. Use a fall protection system when installing. Wear rubber-soled shoes. Walk with care.
 Área resbalosa, especialmente cuando está mojada o helada. Utilice un sistema de protección contra caídas cuando realice la instalación. Use zapatos de bota. Camine con cuidado.

WARNING ADVERTENCIA

Sharp edges. Wear gloves when working. Filos cortantes. Use guantes cuando esté trabajando.

WARNING ADVERTENCIA

Falling hazard. Secure area below work and materials on roof. Unsecured materials may slide on roof. Place on level plane or secure to prevent sliding. Wear a hardhat.
 Peligro de objetos que caen. Seguro área debajo de la zona de trabajo y amarre los materiales al techo. Los materiales que se están sujetos pueden resbalarse del techo. Colóquelos en un lugar que no tenga pendiente, o sujételos para prevenir que se resbalen. Use un casco resistente.

Caution: Safety glasses should always be worn when cutting the roof with a power tool.
 Precaución: Siempre deben utilizarse anteojos de seguridad al cortar el techo con una herramienta eléctrica.

Product Specifications

VentSure® 4-Foot Strip w/Weather PROtector®

Model Name	Width	Color	Material Code	Short Code	NFVA	Shipping Information
4' Strip Heat and Moisture vent w/Nails	12"	Black	796301	VS4N	20 sq. in. per linear ft.	10 pcs/Ctn 12 Ctns/Pallet 48 Pallets/TL
4' Strip Heat and Moisture vent w/ Weather PROtector® moisture barrier	12"	Black	796337	VS4W	20 sq. in. per linear ft.	
4' Strip Heat and Moisture vent w/ Weather PROtector® moisture barrier	10"	Black	796396	VS4TW	18 sq. in. per linear ft.	
4' Strip Heat and Moisture vent w/ Weather PROtector® moisture barrier	8"	Black	796395	VS4EW	18 sq. in. per linear ft.	

VENTSURE® 4' STRIP RIDGE VENT w/Weather PROtector®

VENTSURE® RIGID ROLL RIDGE VENT

with Weather PROtector® Moisture Barrier

What are the advantages of VentSure® Rigid Roll Ridge Vents with Weather PROtector® Moisture Barrier?

- Patented, lightweight, high-density polypropylene construction
- Advanced moisture barrier— no baffles required
- Only 5/8" vent profile
- 20-foot roll is easy to handle and ready to install
- Adjusts to almost any roof pitch (2/12 to 20/12 pitch)*
- Easy to transport and handle
- Rounded peak reduces shingle stress and cracking
- Can be installed with a nail gun
- Won't compress when nailed
- Won't clog or deteriorate like other vents

What materials are required to install a VentSure® Rigid Roll Ridge Vent with Weather PROtector® Moisture Barrier ventilation system?

- VentSure® rigid roll ridge vent with Weather PROtector® moisture barrier
- End cap (included in package)
- Roofing nails
- Construction adhesive or sealant caulk

What tools are required to install a VentSure® Rigid Roll Ridge Vent with Weather PROtector® Moisture Barrier ventilation system?

- Safety goggles
- Utility knife
- Tape measure
- Power saw
- Coil nailer or hammer

What installation precautions should I follow?

- Read all instructions before proceeding
- Always wear safety goggles
- Follow all standard safety precautions

*Refer to local building codes for roof pitch requirements.

What general ventilation tips should I know?

- Do not allow insulation to block undereave vents
- For proper ventilation, adequate intake is necessary to prevent back drafts and assure effectiveness of ridge vent system
- Close off all gable and other roof vent openings
- Do not allow air from home appliances (dryers, range hoods, bathroom fans, etc.) to exhaust into attic—exhaust directly to outdoors

How much ridge/undereave ventilation is required?

In order for your ventilation system to operate properly, a system must be designed to create an airflow that draws air out of the attic at the roof peak and brings air into the attic along the underside of the roof. This can be accomplished by using VentSure® rigid roll ridge vents with Weather PROtector® moisture barrier, which allow air to be drawn out of the attic (exhaust), and soffit vents, which allow air into the attic (intake).

For maximum efficiency, and to create what is considered a balanced system, ventilation should be equal at the soffit and ridge. It is critical to provide proper distribution of ridge and soffit vents. In cases where a balanced system cannot be achieved, always provide more than 50 percent of the total required ventilation at the soffit and the remainder at the ridge. Again, the desired system is to equalize ventilation at both the soffit and ridge areas.



To calculate the minimum amount of total ventilation required, use either the 1/300 or 1/150 ratio. On the inside, the actual calculations have been made for your

convenience. Use the 1/300 ratio if you have proper distribution of soffit and ridge vents or if a vapor retarder is present. Use the 1/150 ratio if proper distribution of soffit and ridge vents cannot be achieved and a vapor retarder is not present.

See the chart on the back page to identify the minimum amount of ridge and soffit ventilation required. Always remember that proper distribution will result in exhaust (ridge vent) and intake (soffit vent). For the best results, run the VentSure® rigid roll ridge vent with Weather PROtector® moisture barrier along the entire peak of the roof in accordance with these application instructions.

The Net Free Vent Area (NFVA) of soffit ventilation should always be at least equal to or more than the net free vent area of the ridge ventilation.

Where can VentSure® rigid roll ridge vents with Weather PROtector® moisture barrier be installed?

Chimney on Roof

- Saw slots to within 12" of any chimney located on ridge as shown and butt ridge vent flush against chimney

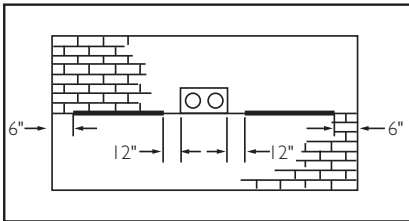

Hip Roof

- Saw slot on center of ridge to within 6" of each end as shown
- Run ridge vent across complete length of ridge

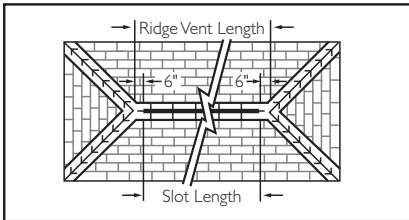

"T" & "L" Roof

- Saw slots to within 12" of ridge intersection points as shown
- Install ridge vent completely across ridge on long side and butt ridge vent

on the short run against the side of the long run

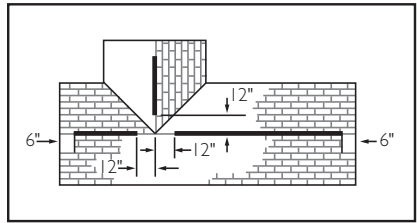

Installation Instructions for VentSure® Rigid Roll Ridge Vent with Weather PROtector® Moisture Barrier

Step 1. Hip and Ridge Ventilation Slot Preparation

Determine how long of a hip and ridge ventilation slot will be required according to 1/300 rule. The ridge and hip ventilation slot may be pre-cut on a new roof before or after shingle installation or in a retrofit, the slot can be cut from the pre-shingled roof using a saw cut from the pre-shingled roof using a carbide tip blade. (Protective eye goggles should be worn during this process). Start ridge ventilation slot 6" from point where hip and ridge meet. Cut a 2" slot (1" on each side of ridge) along the ridge(s). For a roof with a center ridge board, a 3½" slot should be cut (1¾" on each side of ridge). Combined width of slots and ridge board should not exceed 3½". If entire ridge requires ventilation, stop ventilation slot 6" from point where hip and ridge meet. To maintain structural integrity, one continuous slot is not recommended on hip applications. Start ventilation preparation by leaving 6" of hip uncut from where the ridge and hip meet. Cut a 3½" width slot for ventilation. Hip slot should be 18" in length, spaced with a 12" uncut area between each 18" opening. The slot for ventilation should not be cut any lower than the top 1/3 of the roof to maintain a balanced ventilation system.

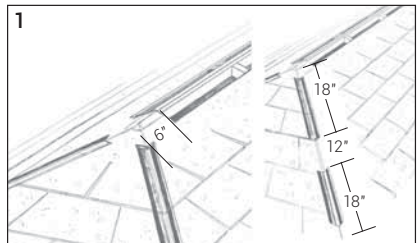

Step 2. Vent Placement on Ridge

Roll out or place VentSure® rigid roll ridge vents with Weather PROtector® moisture barrier along the entire length of slot also covering the 6" minimum uncut ridge on

both ends. Multiple lengths of vent can be joined by butting the sections tightly together. Products with VentSure® rigid roll with Weather PROtector® moisture barrier should have an end cap inserted at the end of each section. (See Step #3)

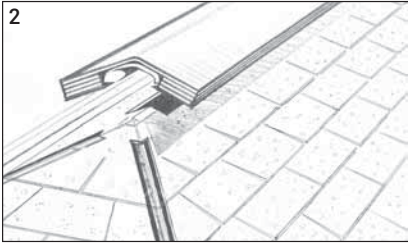

Step 3. End Cap Installation

Install the end caps. Pull apart a pre-cut section of the foam end cap packaged with the vent. For products with VentSure® Rigid Roll with Weather PROtector®, using a utility knife, make a cut in the VentSure® rigid roll with Weather PROtector® material on each side of the vent, back from the end of the roll. (See Fig. 3 inset). Using construction adhesive or sealant caulk, coat both sides of the foam material to ensure a proper seal. Place the foam end cap on top of the VentSure® rigid roll ridge vents with Weather PROtector® material where it has been cut back at the end of the vent. (See illustration #3). Attach vent to the roof deck by driving a nail in each of the two corners on both ends of the vent. Also, drive two nails through the vent and foam end cap to hold foam in place on the ends of the ridge only. Nails should penetrate the wood roof deck at least $\frac{3}{4}$ " into the deck, where the deck is less than $\frac{3}{4}$ " thick the fastener should be long enough to penetrate fully and extend at least $\frac{1}{8}$ " through the roof deck. It is important when installing this vent that you maintain the pitch of the roof. The vent has been installed properly if the bottom of the vent is flat on the roof and the peak is slightly rounded.

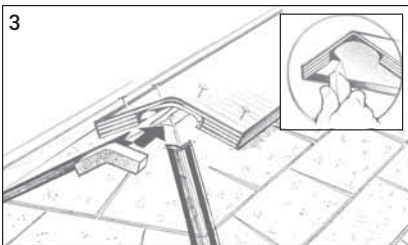

Note: For "Class A" Installation Only

For Class A, VentSure® rigid roll ridge vents with Weather PROtector® moisture barrier

installation follow steps 1, 2, 3 as stated above. Once the vent has been installed, use a Utility knife with a hook blade and remove the corrugated plastic center section of the vent. (See Fig 3B) Do this for the Hip and the Ridge. This modified installation meets the requirements for UL790 Class A, standard installation meets the requirements for UL790 Class C. Follow remaining steps 4, 5, 6 as stated.

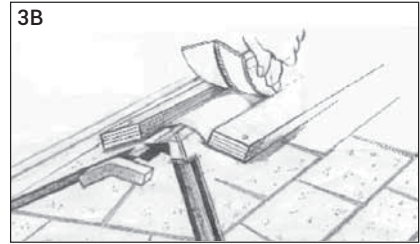

Step 4. Vent Placement on Hip

Install a minimum of two Hip & Ridge shingles at the bottom of the hip. If the VentSure® rigid roll ridge vent with Weather PROtector® moisture barrier is not being run the entire length of the hip, the vent should overlap a minimum of two Hip & Ridge shingles at the end of the vent. Before installing the vent on the hip, lay a bead of sealant on each side of the pre-cut slots. This will create a seal on the step created by overlapping pattern of the shingles. The bead of sealant should be applied approximately 1" from the edge of the pre-cut slot.



Step 5. Hip and Ridge Vent Transition

Using a utility knife, trim the end of VentSure® rigid roll ridge vent with Weather PROtector® moisture barrier from the hip to the ridge. This creates the most attractive ridge and hip line. Insert the foam end cap under the VentSure® rigid roll ridge vent with Weather PROtector® moisture barrier where it is at full width. Fasten vent for hip at point where it meets ridge. Roll out or place the vent all of the way down the hip, covering two pre-laid cap shingles at the bottom of the hip. Go back over hip vents and fasten at 4" intervals.

If the VentSure® rigid roll ridge vent with Weather PROtector® moisture barrier is not being run the entire length of the hip, use the cap shingles to create a transition. Use sealant to fill any void left between the shingles and the remaining top layer of the vent. Be sure to apply roofing sealant to any spaces left by cap shingle used for transition. If two or more sections of VentSure® rigid roll ridge vent with Weather PROtector® moisture barrier are being joined together, an end cap MUST be installed into each end of the joining sections. (See Fig. 3 for end cap installation). Repeat on all hips.

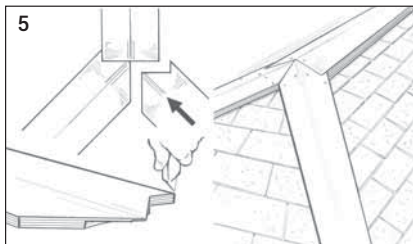

Step 6. Cap Shingle Installation

Apply the Hip and Ridge shingles to the hip and then to the ridge. Nail hip and ridge shingles with roofing nails in a common overlapping pattern. All fasteners must be driven flush with the shingle surface and penetrate at least 3/4" in to the wood deck, where the deck is less than 3/4" thick the fastener should be long enough to penetrate fully and extend at least 1/8" through the roof deck. It is important when installing this vent that you maintain the pitch of the roof. The vent has been installed properly if the bottom of the vent is flat on the roof and the peak is slightly rounded.

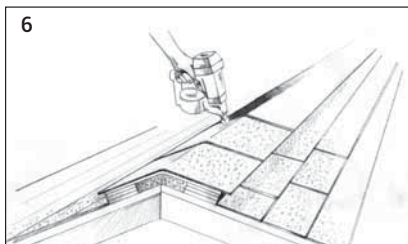

VentSure® rigid roll ridge vent with Weather PROtector® moisture barrier, when properly installed with soffit or eave vents, meets or exceeds the requirements of all recognized national building codes for ventilation. VentSure® rigid roll ridge vent with Weather PROtector® moisture barrier was tested in research and development and passed all tests for weather infiltration. Testing was performed at Architectural Testing Incorporated (ATI) in York, PA.

Wind-Driven Rain—8.8 inches of rain at 110 MPH—Passed.

Snow Infiltration—Snow simulation at 35 and 70 MPH—Passed with no infiltration.

Product Specifications

VentSure® Rigid Roll Ridge Vent

Model Name	Length	Color	Material Code	Short Code	NFVA	Rolls/ PL	Pallets/ TL
Rigid Roll w/Weather PROtector® moisture barrier (11.25")	20'	Black	796266	RR02	12.5 sq. in. per linear ft.	36	52
Rigid Roll w/Weather PROtector® moisture barrier (11.25") with Nails	20'	Black	796288	RR06	12.5 sq. in. per linear ft.	36	52
Rigid Roll w/Weather PROtector® moisture barrier (9")	20'	Black	796268	RR04	12.5 sq. in. per linear ft.	45	52
Rigid Roll w/Weather PROtector® moisture barrier (7")	20'	Black	796267	RR03	12.5 sq. in. per linear ft.	54	52

Ventilation Table: 1/150 Ratio

Attic Square Footage	Square Inches NFVA at Ridge	Min. Feet of Rigid Roll Ridge Vent	Min. Square Inches NFVA at Soffits
1000	480	38	480
1100	528	42	528
1200	576	46	576
1300	624	50	624
1400	672	54	672
1500	720	58	720
1600	768	61	768
1700	816	65	816
1800	864	69	864
1900	912	73	912
2000	960	77	960
2100	1008	81	1008
2200	1056	84	1056
2300	1104	88	1104
2400	1152	92	1152

Use this table if proper distribution of soffit and ridge vents cannot be achieved and a vapor retarder is not present.

Ventilation Table: 1/300 Ratio

Attic Square Footage	Square Inches NFVA at Ridge	Min. Feet of Rigid Roll Ridge Vent	Min. Square Inches NFVA at Soffits
1000	240	19	240
1100	264	21	264
1200	288	23	288
1300	312	25	312
1400	336	27	336
1500	360	29	360
1600	384	31	384
1700	408	33	408
1800	432	35	432
1900	456	36	456
2000	480	38	480
2100	504	40	504
2200	528	42	528
2300	552	44	552
2400	576	46	576

Use this table if you have proper distribution of soffit and ridge vents or a vapor

Note: The above tables are based on minimum FHA vent requirements to meet building codes.

VENTSURE® SKY RUNNER LTE® with nails ROLLED RIDGE VENT

Precautionary Notes:

Read all instructions before proceeding.

When using pneumatic roofing coil nailers, ensure the depth gauge is set to the minimum depth to penetrate $\frac{3}{4}$ inch into the roof deck or completely through the deck by $\frac{1}{8}$ inch. The pressure should be set between 80 and 95 PSI.

Nails must be corrosion-resistant, 11 or 12 gauge, with heads at least $\frac{3}{8}$ inch in diameter and comply with ASTM F1667. Use of ring shank nails may be required by some building codes.¹ All fasteners must be installed flush with the ridge vent surface and penetrate $\frac{3}{4}$ inch into the wood deck or $\frac{1}{8}$ inch through APA (American Plywood Association) rated roof sheathing.

Sky Runner LTE® Vent can be installed on roof pitches ranging from 2:12 to 16:12.

Follow the Occupational Safety and Health Administration (OSHA) safety standard for roofing.

Installation under the HVHZ requirements of the Florida Building Code

Step 1: Determining Ventilation Requirements

Determine the total required length of the ventilation slot according to the 1/150 rule (1 square foot of ventilation area for each 150 square feet of attic floor). For a balanced system, no more than 50% of the required ventilation should be installed at the ridge or hips.

Step 2: Cutting the Vent Slot Opening

- 1) Determine the type of roof framing that is used under the roof sheathing.
- 2) For roofs with a ridge board, cut a $\frac{5}{8}$ inch slot in the roof sheathing beyond each side of the ridge board. For an engineered truss roof, cut a $\frac{5}{8}$ inch slot on each side of the ridge (total slot width of $1\frac{1}{4}$ inches). See Figure 1.

IMPORTANT: Start and end your cut 6 inches in from the rake edges (snapping chalk lines will aid in keeping a uniform ridge opening). Set your saw depth to cut the decking only. Do not cut into the roof framing. See Figure 1.

Note: The ventilation slot may be cut prior to or after shingle installation. If cutting the slot on a roof with shingles installed, use of a circular saw with a carbide tip blade is recommended (Protective eye goggles should be worn during this process).

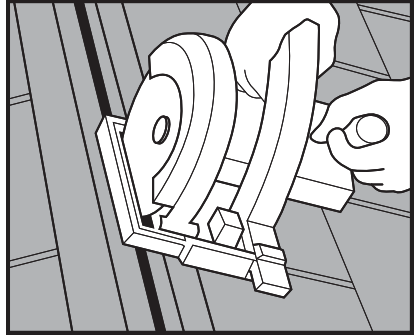

Fig. 1

- 3) Expose the vent slot opening by removing the decking that was just cut between the rake edges. See Figure 2.

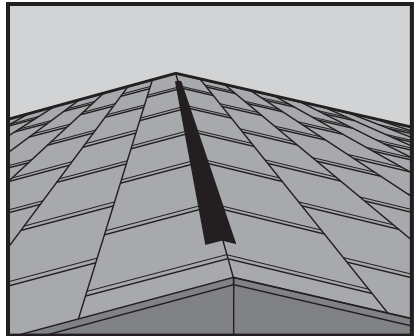

Fig. 2

Step 3: Install shingles up to the ridge slot opening according to shingle manufacturer's instructions.

Step 4: Installing the Ridge Vent

Note: For the best appearance run the ridge vent from rake edge to rake edge.

- 1) Snap a chalk line 7 inches down from the ridge peak on both sides of the ridge from rake edge to rake edge. These will be the alignment lines.

- 2) Center the ridge vent evenly between the chalk lines and secure the starting end with one nail on each side of the vent.
- 3) Roll out the vent along the ridge, using the chalk lines for alignment. Remove any slack from the vent and nail the vent every 6 inches nailing from one side of the vent then the other. See Figure 3.

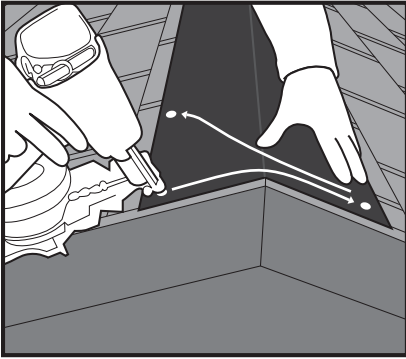

Fig. 3

Note: End plugs are built into the vent every 12 inches. The vent should always begin and end with an end plug. See Figure 4.

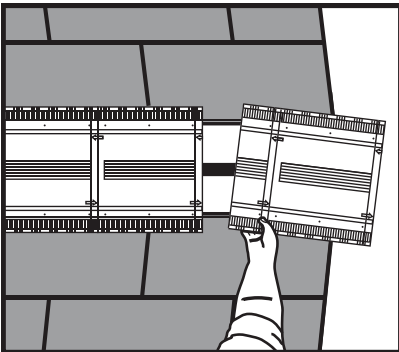

Fig. 4

Cutting Details

The top of the vent provides directional arrows & cut lines to help with beginning and ending installation. When beginning or ending an install, cut the vent on the cut line indicated by the arrow in the direction the vent is being installed. This will ensure the vent will have an end plug at both ends of the rake edge. See Figure 5.

Step 5: Ridge Cap Shingle Application

- 1) Ridge cap shingles should be installed from rake edge to rake edge, starting at the opposite end from which the prevailing winds blow.
- 2) Apply ridge cap shingles over the ridge vent by centering the shingle over the vent.

Note: When nailing the shingles, ensure corrosion resistant, 11 or 12 gauge nails are used with heads at least $\frac{3}{8}$ inch in diameter. All fasteners must be flush with the shingle surface and penetrate $\frac{3}{4}$ inch into the wood deck or $\frac{1}{8}$ inch through APA rated roof sheathing. Cap shingles should be installed per the shingle manufacturer's installation instructions. See Figure 6.

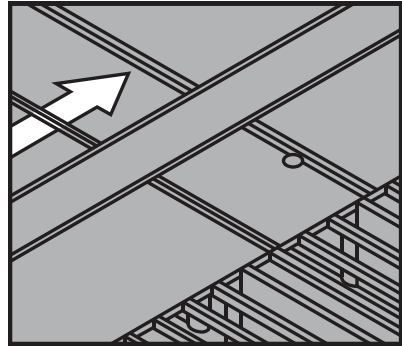

Fig. 5

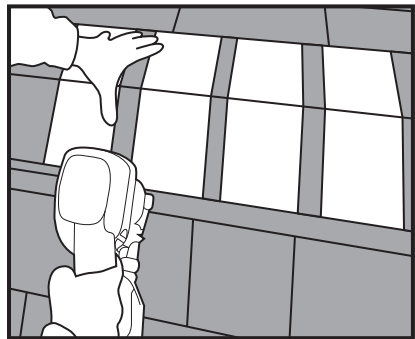

Fig. 6

VentSure® SKY RUNNER LTE® Rolled Ridge Vent is an component of the Owens Corning® Total Protection Roofing System.[^]

[^] Excludes non-Owens Corning® roofing products such as flashing, fasteners, pipe boots and wood decking.

Product Specifications

VentSure® Sky Runner LTE® Rolled Ridge Vent

Model Name	Length	Construction	Color	Material Code	Base	Short Code	NFVA	Rolls/ PL	Pallets/ TL
Sky Runner LTE®	30'	Plastic	Black	803182	12"x360:	SKY30	12 sq. in. per linear ft.	12	52

VENTSURE® SKY RUNNER LTE®

VENTSURE®

RIDGECAT® ROLLED RIDGE VENT

Precautionary Notes:

Read all instructions before proceeding.

When using pneumatic roofing coil nailers, ensure the depth gauge is set to the minimum depth to penetrate at least $\frac{3}{4}$ inch into the roof deck or completely through. The pressure should be set between 80 and 95 PSI.

Nails must be corrosion-resistant, 11 or 12 gauge, with heads at least $\frac{3}{8}$ inch in diameter and comply with ASTM F1667. Use of ring shank nails may be required by some local building codes¹. All fasteners must be installed flush with the ridge vent surface and penetrate $\frac{3}{4}$ inch into the wood deck or $\frac{1}{8}$ inch through APA rated roof sheathing.

RidgeCat™ Vent can be installed on roof pitches ranging from 2:12 to 18:12.

Follow the Occupational Safety and Health Admin (OSHA) safety standard for roofing.

¹ Installation under the HVHZ requirements of the Florida Building Code

Step 1: Determining Ventilation Requirements

1) Determine the total required length of the ventilation slot according to the 1/150 rule (1 square foot of ventilation area for each 150 square feet of attic floor). For a balanced system, no more than 50% of the required ventilation should be installed at the ridge or hips.

Step 2: Cutting the Vent Slot Opening

1) Determine the type of roof framing that is used under the roof sheathing.

2) For roofs with a ridge board, cut a 1 inch slot in the roof sheathing beyond each side of the ridge board. For an engineered truss roof, cut a 1 inch slot on each side of the ridge (total slot width of 2 inches).

IMPORTANT: Start and end your cut 6 inches in from the rake edges (snapping chalk lines will aid in keeping a uniform ridge opening). Set your saw depth to cut the decking only. Do not cut into the roof framing. See Figure 1.

Note: The ventilation slot may be cut prior to or after shingle installation. If installing the slot on a roof with shingles installed, use of a circular saw with a carbide tip blade is recommended (Protective eye goggles should be worn during this process).

3) Expose the vent slot opening by removing the decking that was just cut between the rake edges. See Figure 1.

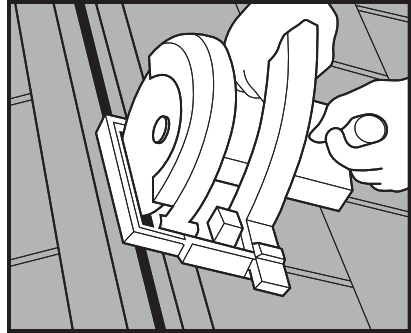

Fig. 1

Step 3: Install shingles up to the ridge slot opening according to shingle manufacturer's instructions.

Step 4: Apply Asphalt Roofing Cement

1) With the shingles installed and the slot opening exposed, install a bead of asphalt roofing cement 3 inches below the vent slot opening on each side of the ridge, and at each end. The sealant should run the entire length of the ridge and should "picture frame" the slot. This will help fill in any gaps between the vent and the shingles, particularly when using laminate shingles. See Figure 2.

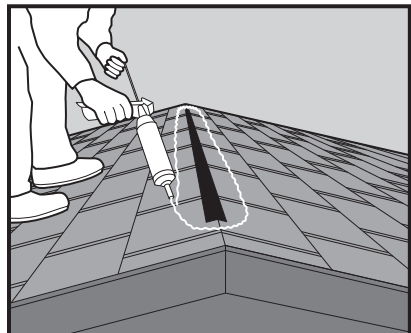

Fig. 2

Note: Use Asphalt Roofing Cement complying with ASTM D4586.

VENTSURE®
RIDGECAT®

Step 5: Installing the Ridge Vent

1) Prior to installing RidgeCat® Vent, cut a minimum 6-inch wide hip & ridge shingle and nail it over the ridge at each rake edge. See Figure 3.

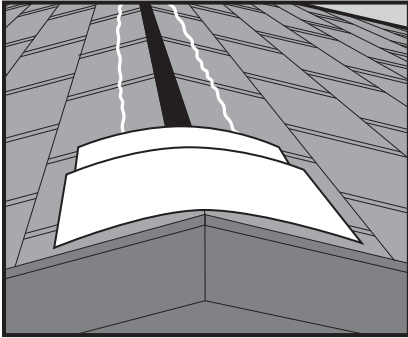

Fig. 3

Note: For the best appearance run the ridge vent from rake edge to the rake edge.

2) Center the RidgeCat® Vent over the slot opening and secure the starting end by applying one nail to the vent on each side of the ridge slot opening, nailing in the printed Tack Line.

Note: The RidgeCat® Vent brand name printed on the center of the vent can be used to help center over the ridge.

3) Roll out the vent along the entire ridge, keeping it centered as you go. Once the vent is rolled out, remove any slack and nail the opposite end as described in the previous step.

4) Secure the vent along the entire ridge by nailing in the printed Tack Lines. One nail should be placed every 3 to 4 feet, on each side of the ridge. See Figure 4.

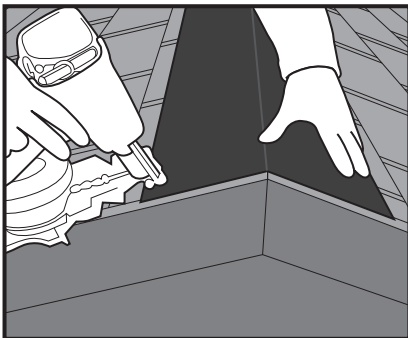

Fig. 4

Note: Nails must penetrate at least $\frac{3}{4}$ inch into the wood deck. If the deck is less than $\frac{3}{4}$ inch thick the nail should be long enough to penetrate fully and extend $\frac{1}{8}$ inch through the roof deck.

Step 6: Connecting Two Pieces of RidgeCat® Vent Together

1) When two separate pieces of RidgeCat® Vent need to be joined together along the ridge, center a cap shingle directly under the location where the vent pieces will be joined together, and secure with 1 nail on each side of ridge.

2) Align the two vent pieces together without overlapping and then fasten by nailing each vent piece on both sides of the ridge to hold the vents in place. See Figure 5.

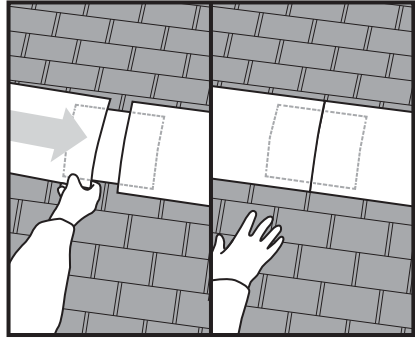

Fig. 5

Step 7: Hip & Ridge Shingle Application

1) Hip & ridge shingles should be installed from rake edge to rake edge, starting at the opposite end from which the prevailing winds blow.

2) Apply hip & ridge shingles over the ridge vent by centering the shingle over the vent.

Note: When nailing the shingles, ensure that corrosion-resistant, 11 or 12 gauge nails are used with heads at least $\frac{3}{8}$ inch in diameter. All fasteners must be flush with the shingle surface and penetrate $\frac{3}{4}$ inch into the wood deck or $\frac{1}{8}$ inch through APA rated roof sheathing. Hip & ridge shingles should be installed per the shingle manufacturer's installation instructions. See Figure 6.

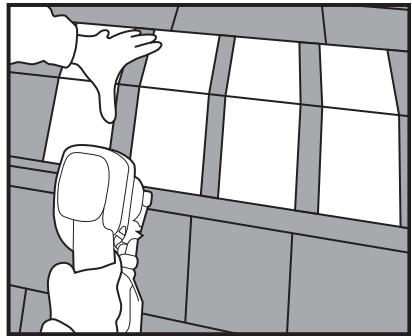

Fig. 6

Note: For installing on roof hips, please call 1-800 GET PINK® (1-800-438-7465) or visit www.owenscorning.com/roofing

Product Specifications

VentSure® RidgeCat® Rolled Ridge Vent

Model Name	Length	Construction	Color	Material Code	Base	Short Code	NFVA	Rolls/ PL	Pallets/ TL
RidgeCat® Rolled Ridge Vent	20'	Nylon	Black	796484	11"x240"	RCAT11	15 sq. in. per linear ft.	36	52
RidgeCat® Rolled Ridge Vent - w/Nails	20'	Nylon	Black	796485	11"x240"	RCAT11N	15 sq. in. per linear ft.	36	52
RidgeCat® Rolled Ridge Vent	20'	Nylon	Black	796487	9"x240"	RCAT9	15 sq. in. per linear ft.	45	52
RidgeCat® Rolled Ridge Vent	20'	Nylon	Black	796488	7"x240"	RCAT7	15 sq. in. per linear ft.	54	52

VENTSURE® PLASTIC SLANT BACK ROOF VENT



Product Benefits:

- Allows outside air to flow naturally upward and out of attic.
- Promotes a cooler, drier attic.
- Helps prevent moisture from being trapped in insulation, structural wood, shingles and roof deck.
- Helps prevent rotting, mildew, drywall damage, peeling paint and warped siding.
- Helps increase the performance of your roof.
- Works year-round for consistent ventilation without energy consumption.

Application

Required Ventilation:

- As a general rule, one square foot of net free vent area per 300 square feet of attic floor or area to be vented is recommended.
- In the rare situation where no vapor retarder is used and/or proper distribution of soffit and ridge vents cannot be achieved, one square foot of net free vent area should be provided for each 150 square feet of attic floor or area to be vented.
- For a balanced system, ventilation should be equal at the undereave and ridge.
- In cases where a balanced system cannot be achieved, always provide more than 50% of the total required ventilation at the undereave and the remainder at the upper portion of the roof.

Installation

1. Place the unit on top of the roof approximately 24" from the top of the ridge. For neat installation, the low profile housing on the unit should be visible only on one side of the roof. When this position is established, locate a centerline directly between two rafters and drill a hole through the roof, from the inside. This hole will be used as a center for the following operations.
2. Draw a circle or square on the roof (refer to chart for opening size), using the drilled hole as the center, and cut the appropriate size hole in the roof. See Figure 1.

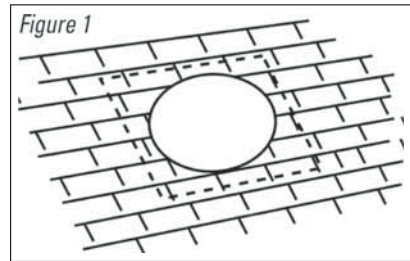

3. With the top of the unit parallel to the ridge line, slide the flange up under the shingles. When installing over an existing roof it may be necessary to remove some additional roofing material and fasteners around the vent for it to fit snugly. See Figure 2. Use roof cement between the flange and shingles approximately 1/2" from the outer edge. Secure with roofing nails long enough to penetrate 3/4" into the wood deck or completely through plywood sheathing with a maximum 4" space between each nail. See Figure 3.

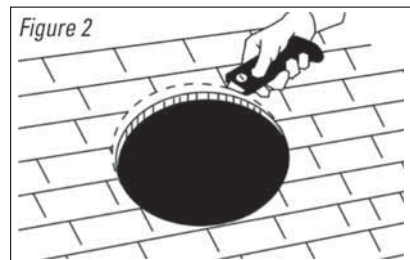
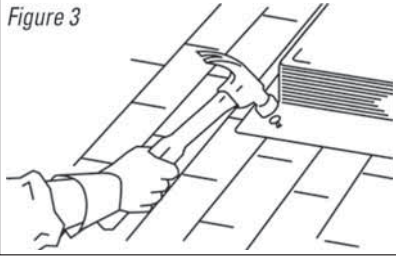

Figure 3



Vent illustrations do not necessarily reflect the individual product style.

Product Specifications

Slant Back

Note: Not currently available for topload as not stocked in plants. Minimum order quantity two pallets.

Model Name	Construction	Color	Material Code	Base	Opening	Short Code	NFVA	Shipping Information
Slant Back	Polypropylene Plastic	Black	796528	19.5"x16.5"	9" diameter	PLSBBL	61 sq. in.	6 pcs/Ctn 24 Ctns/Pallet 26 Pallets/TL
		Weatherwood	796531			PLSBWG	61 sq. in.	

VENTSURE® HIGH PROFILE SLANT BACK ROOF VENT



Product Benefits:

- Allows outside air to flow naturally upward and out of attic.
- Promotes a cooler, drier attic.
- Helps prevent moisture from being trapped in insulation, structural wood, shingles and roof deck.
- Helps prevent rotting, mildew, drywall damage, peeling paint and warped siding.
- Helps increase the performance of your roof.
- Works year-round for consistent ventilation without energy consumption.

Application

Required Ventilation:

- As a general rule, one square foot of net free vent area per 300 square feet of attic floor or area to be vented is recommended.
- In the rare situation where no vapor retarder is used and/or proper distribution of soffit and ridge vents cannot be achieved, one square foot of net free vent area should be provided for each 150 square feet of attic floor or area to be vented.
- For a balanced system, ventilation should be equal at the undereave and ridge.
- In cases where a balanced system cannot be achieved, always provide more than 50% of the total required ventilation at the undereave and the remainder at the upper portion of the roof.

Installation

1. Place the unit on top of the roof approximately 24" from the top of the ridge. For neat installation, the low profile housing on the unit should be visible only on one side of the roof. When this position is established, locate a centerline directly between two rafters and drill a hole through the roof, from the inside. This hole will be used as a center for the following operations.
2. Draw a circle or square on the roof (refer to chart for opening size), using the drilled hole as the center, and cut the appropriate size hole in the roof. See Figure 1.

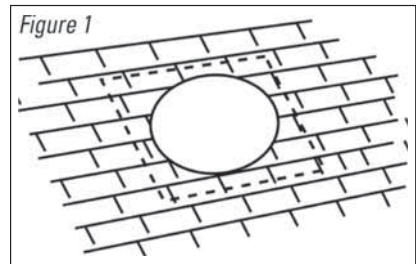

3. With the top of the unit parallel to the ridge line, slide the flange up under the shingles. When installing over an existing roof it may be necessary to remove some additional roofing material and fasteners around the vent for it to fit snugly. See Figure 2.

Use roof cement between the flange and shingles approximately 1/2" from the outer edge. Secure with roofing nails long enough to penetrate 3/4" into the wood deck or completely through plywood sheathing with a maximum 4" space between each nail. See Figure 3.

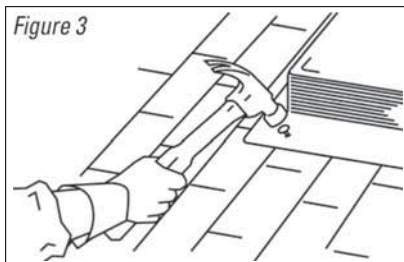
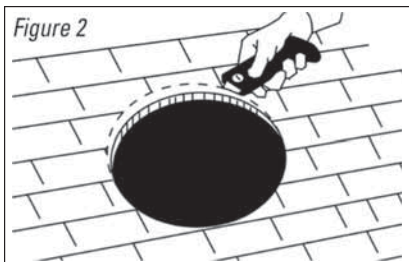

Vent illustrations do not necessarily reflect the individual product style.

Product Specifications

Slant Back

Note: Not currently available for topland as not stocked in plants. Minimum order quantity two pallets.

Model Name	Construction	Color	Material Code	Base	Opening	Short Code	NFVA	Shipping Information
Slant Back	Aluminum	Black	796506	20"x16"	8" diameter	ALSBBL	50 sq. in.	6 pcs/Ctn 12 Ctns/Pallet 52 Pallets/TL
		Brown	796507			ALSBBR	50 sq. in.	
		Weatherwood	796509			ALSBBW	50 sq. in.	
	Galvanized	Black	796502			GVSBBL	50 sq. in.	
		Brown	796505			GVSBBR	50 sq. in.	
		Weatherwood	796504			GVSBBW	50 sq. in.	

VENTSURE® LOW PROFILE SLANT BACK ROOF VENT

Installation Instructions For Owens Corning® VentSure® Low Profile Slant Back Roof Vent

Caution: Roof surface may be slippery, especially when wet or icy. Use a fall precaution system when installing. Wear rubber-soled shoes. Walk with care.

Falling Hazard: Secure area below work and materials on roof. Unsecured materials may slide on roof. Place on level plane or secure to prevent sliding. Wear a hard hat.

1. MARK & CUT

Mark and cut an 11" x 11" hole in the roof deck. (Note: Set blade to thickness of the sheathing.)

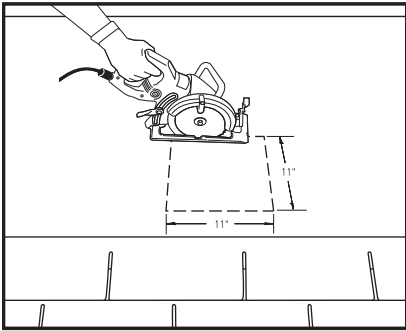

2. SEAL

Seal using sufficient amount of roof cement* around inner and outer flange.

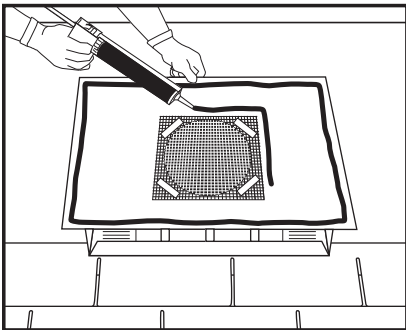

3. PLACE

Place vent directly over the 11" x 11" hole.

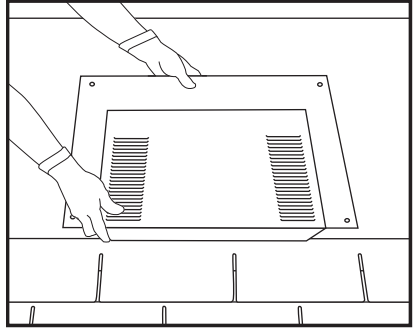

4. SECURE

Secure vent to the roof deck with roofing nails of sufficient length to penetrate 3/4" into wood deck or completely through sheathing, spaced approximately 4" on center and 1" from the outside edge of the flange.

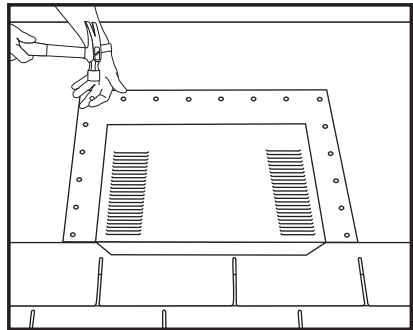

5. COVER

Apply shingles around vent. A 45° angle cut should be made on the material terminating at the vent.

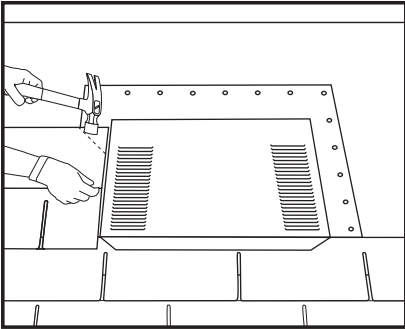

6. TRIM

Cut shingles back 1" on top and sides of vent cover to allow for proper drainage.

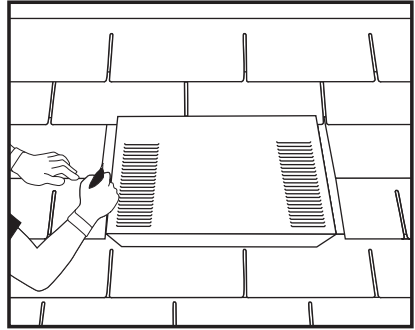

* MEETS ASTM D4586

For more information regarding snow and high velocity wind applications contact Owens Corning at 1-800-GET-PINK®.

Product Specifications

Low Profile Slant Back Vent

NOTE: Currently available in Florida and California and Texas only. Please contact your local Sales Manager for price and availability in other regions. One carton minimum order quantity

Model Name	Construction	Color	Material Code	Base	Opening	Short Code	NFVA	Shipping Information
Low Profile Slant Back	Galvanized Metal	Mill	796278	32"x23"	11" diameter	VS73	72 sq. in.	10 pcs/Ctn 12 Ctns/Pallet 24 Pallets/TL
		Black	796279			VS71	72 sq. in.	
		White	796280			VS72	72 sq. in.	
		Brown	796281			VS74	72 sq. in.	
		Light Gray	796283			VS75	72 sq. in.	
		Dark Gray	796284			VS76	72 sq. in.	
Low Profile Slant Back Extended Flange-CA ONLY	Galvanized Metal	Mill	796293			VS81	72 sq. in.	10 pcs/Ctn 8 Ctns/Pallet 28 Pallets/TL
		Black	796294			VS82	72 sq. in.	
		White	796295			VS83	72 sq. in.	
		Brown	796296			VS84	72 sq. in.	
		Light Gray	796297			VS85	72 sq. in.	
		Dark Gray	796298			VS86	72 sq. in.	

VENTSURE® INFLOW® VENT 4-FOOT STRIP EAVE APPLICATION

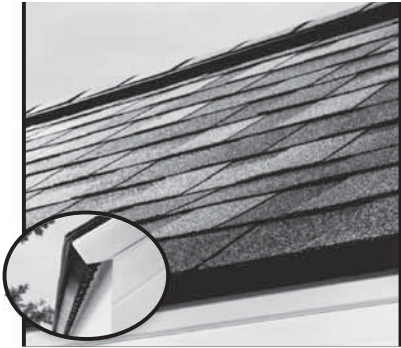

The following instructions are to be used when installing the VentSure® InFlow® Vent at the eave of the roof.

Important Note – Please review the following instructions thoroughly before beginning your installation.

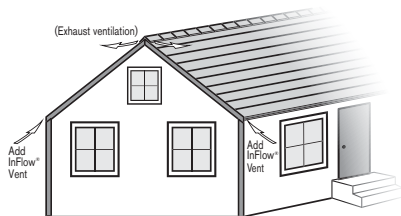

**Typical "Eave" InFlow® Vent Application
Primary Intake on "Cape Cod" or
Other "Soffit-less" Homes**

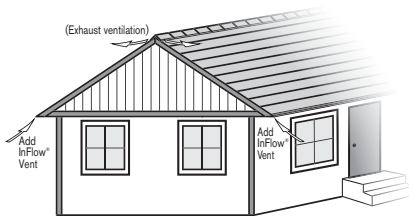

**Typical "Eave" InFlow® Vent Application
Supplemental Intake on Soffit Homes which are
Under-ventilated or where Intake is Blocked**

Precautionary Notes:

Before installing this product, check local building codes for their roofing and ventilation requirements. This vent is designed for new or re-roofing work over any properly built and supported wood roof deck

having adequate nail-holding capacity and a clean, smooth surface.

The InFlow® Vent is designed for roof slopes 4:12 or greater. The manufacturer will not be responsible for issues resulting from any deviation from the recommended application instructions and the following precautions

Roof Deck

- Maximum 6" width and 25/32" minimum thickness wood sheathing
- Minimum 3/8" plywood sheathing or 7/16" OSB
- Sheathing spaced minimum 1/8" and decking spaced maximum 1/4"
- Check local building codes or decking recommended by APA Ventilation
- Must comply with local building code requirements.

Fasteners

- The InFlow® Vent is packaged with 3" ring shank nails to be used when installing the vent and any roofing materials installed directly on the vent.
- Follow roof covering manufacturer's guidelines and local code requirements for all other fasteners.

Tools and materials required to install a VentSure® InFlow® Vent

- Utility knife
- Tape measure
- Circular saw
- Hammer
- 3" Hand Nails (provided with the vent)
- Chalk line
- Underlayment/self-adhering membrane
- Drip edge (for eave)
- Starter and Roofing Shingles
- Rake edge metal (minimum 1 1/4" vertical leg)

Cutting the 1 1/2" Vent Slot Opening

Step 1: Install drip edge along the eave per local code requirements.

Step 2: Chalk a line from rake edge to rake edge that is 6½" above the lower edge of the drip edge or eave edge.

Step 3: Chalk an additional line, 1½" above this line. These lines will identify the top and bottom edges of the vent slot opening.

Step 4: Make marks on the roof 6" in from the gable end wall at each rake edge. The marks will identify the ends of the vent slot opening. See Figure 1.

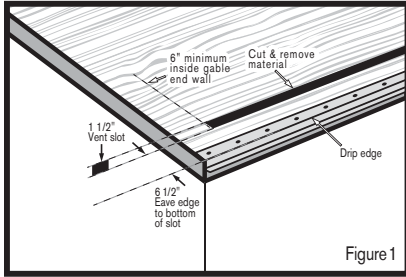

Figure 1

Note: The vent slot opening must stop 6" from chimneys, end walls, vertical walls, or other obstructions, and a minimum of 24" from roof valleys. See Figure 2.

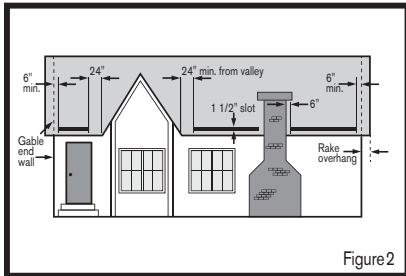

Figure 2

Step 5: Using a circular saw with the depth set to the thickness of the roof deck, cut and remove all materials from the area identified for the vent slot opening.

Note: To provide full ventilation, be sure to maintain at least 1" of clearance between the attic insulation and the bottom of the roof deck.

Installing Underlayment beneath the InFlow® Vent

Step 6: Install a minimum 18" wide piece of underlayment starting at the eave edge. This will cover the slot opening and protect the roof deck below the vent. Identify where the slot opening is underneath the underlayment and cut out the 1½" slot using a sharp utility knife. See Figure 3.

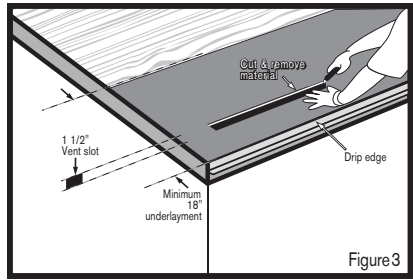

Figure 3

Installing the Vent

Step 7: Position the first InFlow® Vent flush with the rake edge, aligning the vent so the alignment notch is even with the eave edge. This will ensure the vent overhangs the eave edge by 1", allowing air intake through the bottom of the InFlow®. See Figure 4.

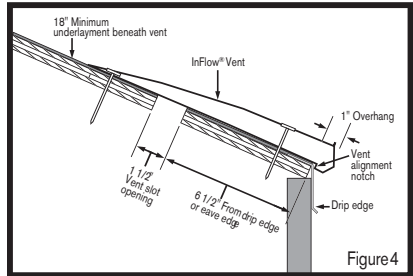

Figure 4

Step 8: Using the nails provided, hand-nail InFlow® Vents in place using the built-in nail holes. Continue installing vents flush with each other from rake edge to rake edge. When installing the final vent, cut the non-rake edge of the vent (if necessary), to ensure a factory-finished edge is flush with the rake edge. See Figure 5.

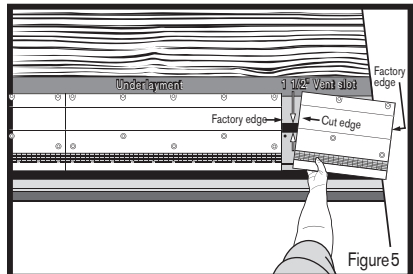

Figure 5

Installing Remaining Shingles & Underlayment

Step 9: Once the InFlow® Vents are installed across the roof, install an underlayment or WeatherLock® Ice & Water Barrier over all vents, at the eave, and at the rake edges per local code requirements. Ensure the bottom edge of the underlayment is flush with the lip at the

lower edge of the vent, completely covering the top intake openings.

IMPORTANT: The InFlow® Vent's top intake openings must be completely covered, as air intake occurs through the bottom of the vent with an eave install. See Figure 6 and 7.

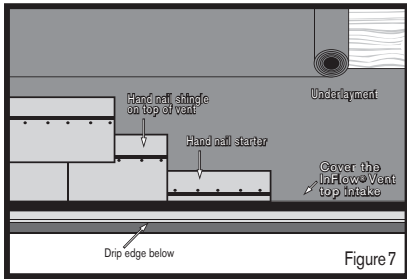
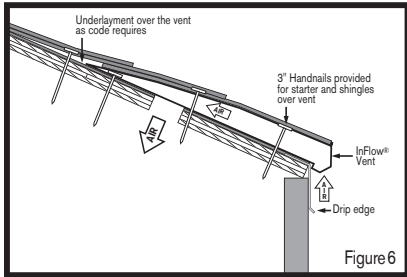

Note: In cold climates where code requires the use of an ice and water barrier, it must extend 24" above the exterior wall. It may be necessary to install a second course of an ice and water barrier to meet this code requirement.

Step 10: Finish installing an approved underlayment over the entire roof, per shingle manufacturer's instructions. Once the underlayment is in place, install rake edge metal over the entire rake, including the InFlow® Vent.

Note: Rake edge metal with a 1 1/4" minimum vertical leg will completely conceal the factory-finished edge of the InFlow® Vent.

Step 11: Hand nail the starter and roofing shingles on top of the vent using the 3" nails provided. See Figures 6 and 7.

Note: Be sure that all nails fully penetrate the wood deck and do not fall within the vent slot opening. Consult your shingle manufacturer for recommendations as required.

Step 12: Continue shingle system installation per manufacturer's specifications.

Note: A nail gun and standard roofing nails can be used to install shingle courses above the InFlow® Vent, per shingle manufacturer's specification.

VentSure® InFlow® Vent 4-Foot Strip Mid-Roof Application

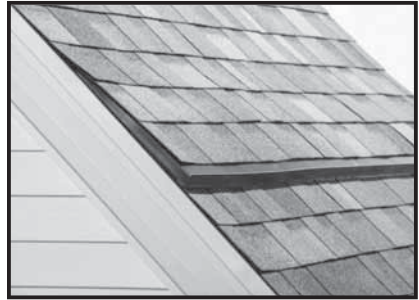

The following instructions are for installing the VentSure® InFlow® Vent up the roof slope beyond the eave, where eave application is not possible or will not allow proper intake ventilation into the attic space.

Important Note – Please review the following instructions thoroughly before beginning your installation.

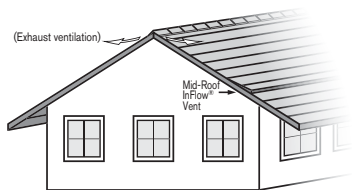

**Typical "Mid-Roof" InFlow® Vent Application
Exposed Rafters or Open Soffits**

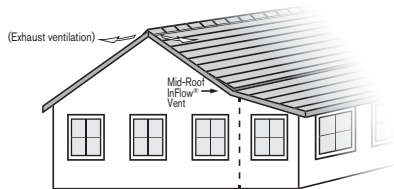

**Typical "Mid-Roof" InFlow® Vent Application
Conditioned Living Area to Unconditioned Porch**

Precautionary Notes:

Before installing this product, check local building codes for their roofing and ventilation requirements. This vent is designed for new or re-roofing work over any properly built and supported wood roof deck having adequate nail-holding capacity and a clean, smooth surface.

The InFlow® Vent is designed for roof slopes 4:12 or greater. The manufacturer will not be responsible for issues resulting from any deviation from the recommended application instructions and the following precautions:

Roof Deck

- Maximum 6" width and 25/32" minimum thickness wood sheathing
- Minimum 3/8" plywood sheathing or 7/16" OSB
- Sheathing spaced minimum 1/8" and decking spaced maximum 1/4"
- Check local building codes or decking recommended by APA

Ventilation

- Must comply with local building code requirements.

Fasteners

- The InFlow® Vent is packaged with 3" ring shank nails to be used when installing the vent and any roofing materials installed directly on the vent.
- Follow roof covering manufacturer's guidelines and local code requirements for all other fasteners.

Tools and materials required to install a VentSure® InFlow® Vent:

- Utility knife
- Tape measure
- Circular saw
- Hammer
- 3" Hand Nails (provided with the vent)
- Chalk line
- Underlayment/self-adhering membrane
- Starter and Roofing Shingles

Installing Initial Courses of Shingles & Underlayment

Step 1: Starting at the eave's edge and continuing up two courses beyond the exterior wall beneath the roof, install shingles and underlayment per manufacturer's instructions. Nail the

second course of shingles 4 1/2" above the lower edge of this same shingle course. See Figure 1.

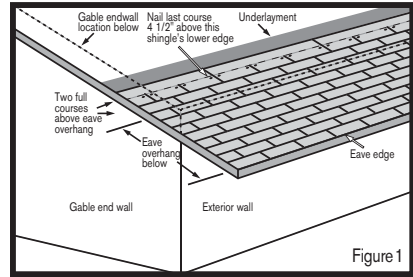

Cutting the 1 1/2" Vent Slot Opening

Step 2: Chalk a line from rake edge to rake edge that is 5" above the lower edge of the last course of shingles installed.

Step 3: Chalk an additional line, 1 1/2" above this line. These lines will identify the top and bottom edges of the vent slot opening.

Step 4: Make marks on the roof 6" in from the gable end wall at each rake edge. The marks will identify the ends of the vent slot opening. See Figure 2.

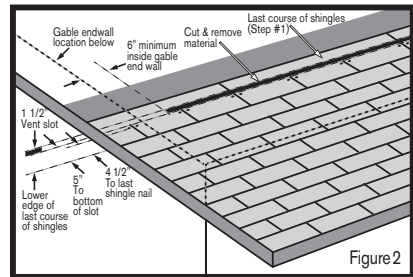

Note: The vent slot opening must stop 6" from chimneys, end walls, vertical walls, or other obstructions, and a minimum of 24" from roof valleys. See Figure 3.

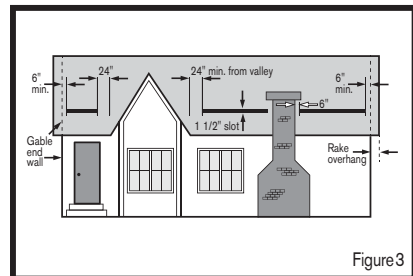

Step 5: Using a circular saw with the depth set to the thickness of the roofing materials plus the roof deck, cut and remove all materials from the area identified for the vent slot opening.

Note: To provide full ventilation, be sure to maintain at least 1" of clearance between the attic insulation and the bottom of the roof deck.

Installing the Vent

Step 6: Position the first InFlow® Vent flush with the rake edge, aligning the vent so the alignment notch is even with the lower edge of the last shingle course installed. See Figure 4.

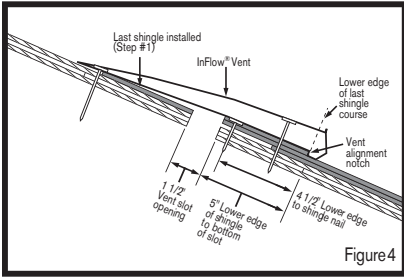

Figure 4

Step 7: Using the nails provided, hand-nail the InFlow® Vent in place using the built-in nail holes. Continue installing vents flush with each other from rake edge to rake edge. When installing the final vent, cut the non-rake edge of the vent (if necessary), to ensure a factory-finished edge is flush with the rake edge. See Figure 5.

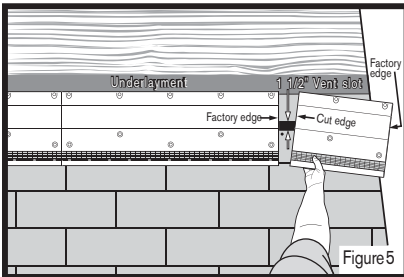

Figure 5

Installing Remaining Shingles & Underlayment

Step 8: Once the InFlow® Vent is installed, install underlayment and hand nail starter shingles and one course of roofing shingles on top of the vent using the 3" nails provided. **IMPORTANT: Do not cover the InFlow® Vent's top intake openings.** This will allow air intake through the top of the vent.

Note: Ensure all nails fully penetrate the wood deck and do not fall within the vent slot opening. Consult your shingle manufacturer for recommendations if needed. See Figures 6 & 7.

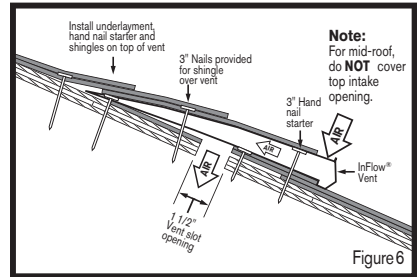

Figure 6

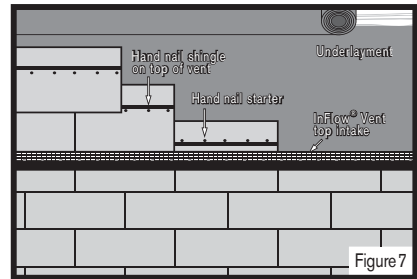

Figure 7

Step 9: Continue shingle system installation per manufacturer's specifications.

Note: A nail gun and standard roofing nails can be used to install shingle courses above the InFlow® Vent, per manufacturer's specification.

For installation conditions which are not addressed by these instructions, please contact us at 1-800-GET-PINK (1-800-438-7465) or visit www.owenscorning.com for further instructions.

Product Specifications

VentSure® InFlow® Vent

NOTE: Topload out of select plants; MINIMUM Order Quantity 1 Pallet/TL; Topload MAXIMUM Order Quantity 12 Pallets/TL; Can be mixed with 4-Foot Strip Ridge Vent with Weather PROtector® as a Full Truckload order from plant 9800; Can only be ordered in full pallet quantity.

Model Name	Color	Material Code	Base	Short Code	NFVA	Shipping Information
4-Foot Strip InFlow® Vent w/Weather PROtector® moisture barrier	Black	796449	11"x48"	VIN4NF	10 sq. in. per linear ft.	10 pcs/Ctn 6 Ctns/Pallet 48 Pallets/TL



Preventing Damage from Ice Dams

Snow and ice formations on roofing structures can create ice dams at the roof eaves. Ice dams are typically formed by the continual thawing and freezing of melting snow or backing up of frozen slush in gutters. When ice dams occur, water can be forced under the roof and may cause damage to a home's ceilings, walls and insulation, and long-term damage to structural components.

The installation of eave flashing is the recommended method for preventing leakage from ice dams. In climates where icing along the eave is anticipated (where the average January temperature is 25°F or less), eave flashing must be installed to ensure maximum protection against ice dam damage. The appropriate selection of flashing material and the flashing strip width will depend on the roof slope and the severity of icing conditions anticipated.

I. New Construction

Low Slope Application:

On pitches 2 inches per foot to 4 inches per foot, cover the deck with a self-adhering waterproofing underlayment. These underlayments come in various widths and lengths. Begin by applying the self-adhering underlayment along the eave flush

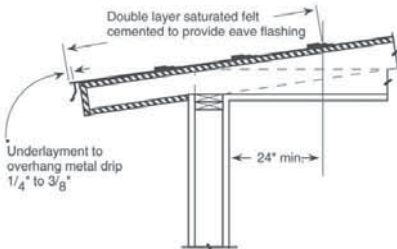

Figure A: Eaves flashing for low slope using asphalt saturated felt

with the drip edge. All succeeding courses will be overlapped according to the manufacturer's instructions. In all applications the product should extend

a minimum of 24 inches inside the interior wall line of the building.

As an alternative on pitches 2 inches per foot to 4 inches per foot, cover the deck with two layers of asphalt saturated felt. Begin by applying the felt in a 19 inches wide strip along the eaves and overhanging the drip edge by 1/4 to 3/4 inches. Place a full 36 inches wide sheet over the 19 inches wide starter piece, completely overlapping it. All succeeding courses will be positioned to overlap the preceding course by 19 in. If winter temperatures average 25°F or less, thoroughly cement the felts to each other with plastic cement from eaves and rakes to a point of a least 24 inches inside the interior wall line of the building.

Normal Slope (4 inches per foot or greater):

In areas where ice builds up along the eave or a backup of water from frozen or clogged gutters is a potential problem, self-adhering underlayments (or any specialty eave flashing product) may be applied to eaves, rakes, ridges and valleys, and around chimneys, skylights or dormers to help prevent water damage. Start the first course at the eave, applying flush with the drip edge. Apply the self-adhering membrane to a point at least 24 inches inside the interior wall line.

If self-adhering membranes are not available, install a course of smooth, coated roll roofing, not less than 50 pounds, and parallel to the eave. This course should overhang both the underlayment and the metal drip edge by 1/4 to 3/4. Starting at the eave, apply the roll roof flashing strip to a point at least 24 inches beyond the interior wall line. If a second flashing strip is required to reach that point, locate the lap in front of the exterior wall line. Overlap the flashings at least 2 inches and cement the horizontal joint over its entire length. End laps should be 6 inches and cemented. See Figure B.

II. Reroofing and Repair

When repairing or reroofing over an existing roof, remove the old roofing to a point at least 24 inches beyond the interior wall line and follow the application instructions above for the appropriate roof slope.

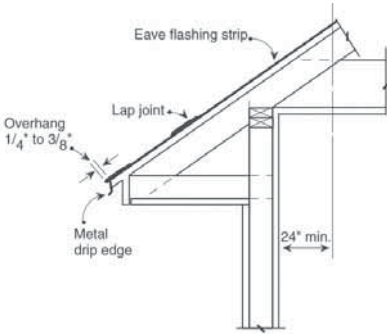

Figure B: Eaves flashing for normal slope using asphalt saturated felt

DISCLAIMER OF LIABILITY: This document was prepared by the Asphalt Roofing Manufacturers Association and is disseminated for informational purposes only. Nothing contained herein is intended to revoke or change the requirements or specifications of the individual roofing material manufacturers or local, state and federal building officials that have jurisdiction in your area. Any question, or inquiry, as to the requirements or specifications of a manufacturer, should be directed to the roofing manufacturer concerned. THE USER IS RESPONSIBLE FOR ASSURING COMPLIANCE WITH ALL APPLICABLE FOR ASSURING COMPLIANCE WITH ALL APPLICABLE LAWS AND REGULATIONS. Nothing contained herein shall be interpreted as a warranty by ARMA, either express or implied, including but not limited to the implied warranties of merchantability, fitness for a particular purpose or non-infringement. IN NO EVENT SHALL ARMA BE LIABLE FOR ANY DAMAGES WHATSOEVER, including special, indirect, consequential or incidental damages or damages for loss of profits, revenue, use or data, whether claimed in contract, tort or otherwise. Where exclusion of implied warranties is not allowed, ARMA's liability shall be limited to the minimum scope and period permitted by law.



Decorative Rake Trim as an Alternative to Drip Edge

Key consideration:

- Drip edge helps in preventing wind driven rain from entering the roofing system
- Drip edge is required for the Platinum & Preferred Warranties
- Drip edge may be required by local building codes

Owens Corning Roofing and Asphalt LLC Position:

Because of architectural designs of homes may already be in place. These edging are primarily vinyl, wood or metal and are designed for greater rake trim appeal. When trim edge of this style is used it is not practical to use a standard type drip edge metal without it affecting the architectural look of the home.

Owens Corning will allow as an exception the use of existing trim edge to be used as an alternative to drip edge metal.

Shown below are a few examples:

Metal

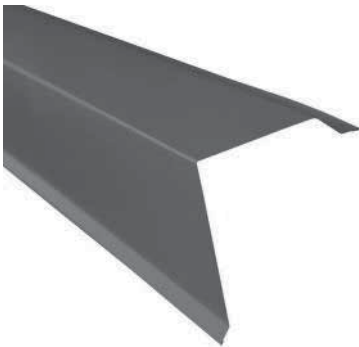

Wood



AFF-008-F



Sidewall and Front Wall Flashing

Key consideration:

- Sidewall and Front wall flashing is required by building code
- New flashing is required for the Platinum and Preferred warranties
- Properly installed flashing helps to direct water away from wall penetrations

Owens Corning Roofing and Asphalt LLC Position:

Because of certain types of architectural designs of homes we understand that different style of siding can be used. An example of these are vinyl, aluminum, wood, stucco, brick and cementitious type board.

When reroofing a home with the above example siding it may become difficult to replace existing flashing without damaging the siding. This sometimes create a challenge for the roofing contractor on what is the best solution for replacing/removing old flashing.

Position

Owens Corning will allow using existing flashing under the following conditions.

- The existing flashing should be in like-new condition
- It must be of the proper size and gauge required by local building codes
- It must be installed per the manufactures and building codes requirements

Do not use existing flashing that is.

1. Buckled
2. Rusted
3. Bent
4. Cracked
5. Broken

If you have any questions prior to re-using any existing flashing contact Owens Corning Roofing Technical Department.

OWENS CORNING®

EXTENDED WARRANTY COVERAGE

ELIGIBILITY REQUIREMENTS



Extended Warranty Requirements

General Requirements

- Must be installed by a qualified Preferred or Platinum Contractor
- Contractor must register warranty within 60 days of installation
- Contractor must meet Owens Corning components requirements
- For workmanship warranties - must pass random Quality Assurance inspections

Other Roof System Requirements

- Roof must meet local code requirements
- Full roof only – no partial roofs
- Must be installed on clean deck
- Deck must be minimum 7/16"
- Minimum 7/16" OSB, 3/8" plywood, or 6" wide x 3/4" thick boards, with gaps between boards 1/4" or less
- Must have drip edge – on rakes and eaves
- Must be ventilated – no exceptions
- Must have new metal flashings – some exceptions apply
- Low slopes, 2/12 to $4/12$ must have double underlayment layered 50% plus 1 inch or Ice & Water Barrier over entire deck.

OWENS CORNING RESOURCES



LEARN ABOUT OWENS CORNING UNIVERSITY

OCU is not just in demand, it's on demand. When, where, and how you want it.

To fit into your busy schedule, you can customize OCU training and educational opportunities to meet your individual business needs. The best part – you are already enrolled and ready to go.

LIVE & ONLINE EDUCATION

Owens Corning University (OCU) helps you work smarter, not harder. From lead generation and sales tools to product and installation information, OCU is your all-in-one educational tool. The best part – you are already enrolled and ready to go. What's in it for you? Well, we're glad you asked. With OCU, you can:



**ONBOARD NEW
EMPLOYEES FASTER**



**LEARN PRODUCT
INSTALLATION BEST
PRACTICES**



**HELP CLOSE
MORE SALES**



**CUSTOMIZE
TRAINING FOR
YOUR BUSINESS**



**FINE-TUNE YOUR
PRESENTATIONS**



**5, 10, OR 15
MINUTE
MODULES**

For more information, contact your Owens Corning area sales manager or call 1-866-PRODESK (776-3375), Monday - Friday, 8 a.m. - 8 p.m. EST.

GLOSSARY OF TERMS

Algae Discoloration: A type of roof discoloration caused by algae. Commonly described incorrectly as fungus growth.

ASTM International: A voluntary organization concerned with development of consensus standards, testing procedures and specifications.

Asphalt: A bituminous waterproofing agent applied to roofing materials during manufacture.

Asphalt Primer: A thin liquid bitumen applied to a surface to improve the adhesion of self-adhering membranes and to absorb dust.

Asphalt Roof Cement: An asphalt-based cement used to bond roofing materials. Also known as flashing cement or mastic; should conform to ASTM D4586 (Asbestos Free).

Back Surfacing: Fine mineral matter applied to the back side of shingles to keep them from sticking together.

Base Flashing: That portion of the flashing attached to or resting on the deck to direct the flow of water onto the roof covering.

Base-ply sheet: A product intended to be the base or middle ply in a residential self-adhering roll roofing installation.

Base Sheet: A product intended to be used as a base ply in a self-adhering roll roofing installation.

Blisters: Bubbles that may appear on the surface of asphalt roofing after installation.

Brands: Airborne burning embers released from a fire.

Bridging: A method of reroofing with metric-size shingles.

Built-Up Roof: A flat or low-sloped roof consisting of multiple layers of asphalt and ply sheets.

Bundle: A package of shingles. There are typically 3, 4 or 5 bundles per square.

Butt edge: The lower edge of the shingle tabs. (See Figure A.)

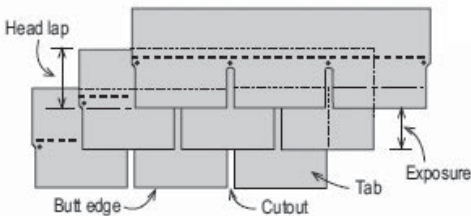

Figure A

Cap Sheet: A mineral surfaced material that is used by itself or as the top layer of multiple roof covering systems.

Caulk: To fill a joint with mastic or asphalt cement to prevent leaks.

Cement: See Asphalt Roof Cement.

Chalk Line: A line made on the roof by snapping a taut string or cord dusted with chalk. Used for alignment purposes.

Class "A": The highest fire test classification for roofing as per ASTM E108 or UL790. Indicates roofing is able to withstand severe exposure to fire originating from sources outside the building.

Class "B": Fire test classification that indicates roofing material is able to withstand moderate exposure to fire originating from sources outside the building.

Class "C": Fire test classification that indicates roofing material is able to withstand light exposure to fire originating from sources outside the building.

Closed Cut Valley: A method of valley treatment in which shingles from one side of the valley extend across the valley while shingles from the other side are trimmed 2" from the valley centerline. The valley flashing is not exposed.

Coating: A layer of viscous asphalt applied to the base material into which granules or other surfacing is embedded.

Collar: Pre-formed flange placed over a vent pipe to seal the roof around the vent pipe opening. Also called a vent sleeve.

Concealed Nail Method: Application of roll roofing in which all nails are driven into the underlying course of roofing and covered by a cemented, overlapping course. Nails are not exposed to the weather.

Condensation: The change of water from vapor to liquid when warm, moisture-laden air comes in contact with a cold surface.

Counter Flashing: That portion of the flashing attached to a vertical surface to prevent water from migrating behind the base flashing.

Course: A row of shingles or roll roofing running the length of the roof.

Coverage: The number of layers of material between the exposed surface of the roofing and the deck; i.e., single coverage, double coverage, etc.

Cricket: A peaked saddle construction at the back of a chimney to prevent accumulation of snow and ice and to deflect water around the chimney.

Cutout: The open portions of a strip shingle between the tabs. (See Figure A.)

Deck: The surface, installed over the supporting framing members, to which the roofing is applied. The minimum thickness of a wood deck is a 15/32" exterior grade plywood or 7/16" exterior grade OSB or as required by local building codes.

Dormer: A framed window unit projecting t **Figure B** lane of a roof. (See Figure B.)

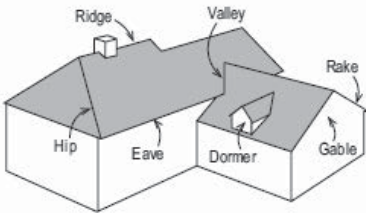

Figure B



Double Coverage: Application of asphalt roofing such that the lapped portion is at least 2" wider than the exposed portion, resulting in two layers of roofing material over the deck.

Downspout: A pipe for draining water from roof gutters. Also called a leader.

Drip Edge: A corrosion-resistant, non-staining material used along the eaves and rakes to allow water run-off to drip clear of underlying construction.

Eave: The horizontal, lower edge of a sloped roof. (See Figure B.)

Eave Flashing: Additional layer of roofing material applied at the eaves to help prevent damage from water back-up.

Exposed Nail Method: Application of roll roofing in which all nails are driven into the cemented, overlapping course of roofing. Nails are exposed to the weather.

Exposure: That portion of the roofing exposed to the weather after installation. (See Figure A.)

Felt: Fibrous material saturated with asphalt and used as an underlayment or sheathing paper.

Fiberglass Mat: An asphalt roofing base material manufactured from glass fibers.

Flashing: Pieces of metal used to prevent seepage of water into a building around any intersection or projection in a roof such as vent pipes, chimneys, adjoining walls, dormers

and valleys. Galvanized metal flashing should be minimum 26-gauge.

Flashing cement: See Asphalt Roof Cement.

FM Global: A service mark of the Factory Mutual Insurance Company.

Free-Tab Shingles: Shingles that do not contain factory-applied strips or spots of self-sealing adhesive.

Gable: The upper triangular portion of a sidewall that comes to a point at the ridge of a double sloping roof. (See Figure B.)

Gable Roof: A simple two-sided roof above a gable.

Gambrel Roof: A type of roof containing two sloping planes of different pitch on each side of the ridge. The lower plane has a steeper slope than the upper. Contains a gable at each end.

Granules: Typically ceramic-coated colored crushed rock that is applied to the exposed surface of asphalt roofing products.

Gutter: The trough that channels water from the eaves to the downspouts.

Head Lap: Shortest distance from the butt edge of an overlapping shingle to the upper edge of a shingle in the second course below. The triple coverage portion of the top lap of strip shingles. (See Figure A.)

Hexagonal Shingles: Shingles that have the appearance of a hexagon after installation.

Hip: The inclined external angle formed by the intersection of two sloping roof planes. Runs from the ridge to the eaves. (See Figure B.)

Hip Roof: A type of roof containing sloping planes on each of four sides. Contains no gables.

Hip Shingles: Shingles used to cover the inclined external angle formed by the intersection of two sloping roof planes.

Ice Dam: Condition formed at the lower roof edge by the thawing and re-freezing of melted snow on the overhang. Can force ponded water up and under shingles, causing leaks.

Interlocking Shingles: Individual shingles that mechanically fasten to each other to provide wind resistance.

Laminated Shingles: Strip shingles containing more than one layer to create extra thickness. Also called three-dimensional shingles or architectural shingles.

Lap: To cover the surface of one shingle or roll with another.

Lap Cement: An asphalt-based cement (conforming to ASTM D3019) used to adhere overlapping plies of roll roofing.

Low Slope Application: Method of installing asphalt shingles on roof slopes 2"- 4" per foot.

Mansard Roof: A type of roof containing two sloping planes of different pitch on each of four sides. The lower plane has a much steeper pitch than the upper, often approaching vertical. (See Figure B.)

Masonry Primer: An asphalt-based primer used to prepare masonry surfaces for bonding with other asphalt products.

Mastic: See Asphalt Roof Cement.

Mid-ply Sheet: see Base-ply sheet.

Mineral Stabilizers: Finely ground limestone, slate, trap rock or other inert materials added to asphalt coatings for durability and increased resistance to fire and weathering.

Mineral-Surfaced Roofing: Asphalt shingles and roll roofing that are covered with granules.

Nesting: A method of reroofing with new asphalt shingles over old shingles in which the top edge of the new shingle is butted against the bottom edge of the existing shingle tab.

No-Cutout Shingles: Shingles consisting of a single, solid tab with no cutouts.

Non-Veneer Panel: Any wood-based panel that does not contain a laminated veneer and carries an APA span rating, such as wafer board or oriented strand board.

Open Valley: Method of valley construction in which shingles on both sides of the valley are trimmed along a chalk line snapped on each side of the valley. Shingles do not extend across the valley. Valley flashing is exposed.

Organic Felt: An asphalt roofing base material manufactured from cellulose fibers.

Overhang: That portion of the roof structure that extends beyond the exterior walls of a building.

Pallets: Wooden platforms used for storing and shipping bundles of shingles.

Pitch: The degree of roof incline expressed as the ratio of the rise, in feet, to the span, in feet; pitch is 1/2 of slope.

Ply: A layer of roofing (i.e., one-ply, two-ply).

Ponding: The accumulation of water after rainfall at low-lying areas on a roof that remains wet when other parts of the roof have dried.

Racking: Roofing application method in which shingle courses are applied vertically up the roof.

Rafter: The supporting framing member immediately beneath the deck, sloping from the ridge to the wall plate.

Rake: The inclined edge of a sloped roof over a wall. (See Figure B.)

Random-Tab Shingles: Shingles on which tabs vary in size and exposure.

Release Tape: A plastic or paper strip that is applied to the back of self-sealing shingles. This strip prevents the shingles from sticking together in the bundles, and need not be removed for application.

Reroofing: The process of recovering or replacing an existing roofing system.

Ridge: The uppermost, horizontal external angle formed by the intersection of two sloping roof planes. (See Figure B.)

Ridge Shingles: Shingles used to cover the horizontal external angle formed by the intersection of two sloping roof planes.

Rise: The vertical distance from the eaves line to the ridge.

Roll Roofing: Asphalt roofing products manufactured in roll form.

Roofing Tape: An asphalt-saturated tape used with asphalt cements for flashing and patching asphalt roofing.

Run: The horizontal distance from the eaves to a point directly under the ridge. One half the span.

Saturant: Asphalt used to impregnate an organic felt base material.

Saturated Felt: An asphalt-impregnated felt used as an underlayment between the deck and the roofing material.

Self-Adhering Shingle Underlayment: A self-adhering waterproofing shingle underlayment designed to protect against water infiltration due to ice dams or wind driven rain.

Self-Sealing Shingles: Shingles containing factory-applied strips or spots of self-sealing adhesive.

Self-Sealing Strip or Spot: Factory-applied adhesive that bonds shingle courses together when exposed to the heat of the sun after application.

Selvage: That portion of roll roofing overlapped by the succeeding course to obtain single or double coverage at the lap.

Shading: Slight differences in shingle color that may occur as a result of normal manufacturing operations.

Sheathing: See Deck.

Shed Roof: A roof containing only one sloping plane. Has no hips, ridges, valleys or gables.

Single Coverage: Asphalt roofing that provides one layer of roofing material over the deck.

Slope: The degree of roof incline expressed as the ratio of the rise, in inches, to the run, in feet.

Smooth-Surfaced Roofing: Roll roofing that is covered with ground talc or mica instead of granules (coated).

Soffit: The finished underside of the eaves.

Soil Stack: A vent pipe that penetrates the roof.

Span: The horizontal distance from eave to eave.

Square: A unit of roof measure covering 100 sq ft.

Square-Tab Shingles: Shingles on which tabs are all the same size and exposure.

Standard Slope Application: Method of installing asphalt shingles on roof slopes 4" - 21" per foot.

Starter Strip: Asphalt roofing applied at the eave that provides protection by filling in the spaces under the cutouts and joints of the first course of shingles.

Steep Slope Application: Method of installing asphalt shingles on roof slopes greater than 21" per foot.

Strip Flashing: Base flashing application method used where a vertical surface meets a sloping roof plane.

Strip Shingles: Asphalt shingles that are approximately three times as long as they are wide.

Tab: The exposed portion of strip shingles defined by cutouts. (See Figure A.)

Talc: See Back Surfacing.

Tear Off: To remove an existing roofing system down to the structural deck.

Telegraphing: A shingle distortion that may arise when a new roof is applied over an uneven surface.

Three-Dimensional Shingles: See laminated shingles.

Top Lap: That portion of the roofing covered by the succeeding course after installation. (See Figure A.)

UL: Underwriters Laboratories, LLC

UL Label: Label displayed on packaging to indicate the level of fire and/or wind resistance of asphalt roofing.

Underlayment: Asphalt saturated felt or specially engineered synthetic material used beneath roofing to provide additional protection for the deck.

Valley: The internal angle formed by the intersection of two sloping roof planes. (See Figure B.)

Vapor Retarder: Any material used to prevent the passage of water vapor.

Vent: Any outlet for air that protrudes through the roof deck such as a pipe or stack. Any device installed on the roof, gable or soffit for the purpose of ventilating the underside of the roof deck.

Vent Sleeve: See Collar.

Woven Valley: Method of valley construction in which shingles from both sides of the valley extend across the valley and are woven together by overlapping alternate courses as they are applied. The valley flashing is not exposed.

PEACE OF MIND FOR YOUR BIGGEST INVESTMENT - YOUR HOME

TOTAL PROTECTION. TOTAL CONFIDENCE®.



It takes more than just shingles to protect your home. It takes an integrated system of components and layers designed to withstand the forces of nature outside while controlling temperature and humidity inside.

The Owens Corning® Total Protection Roofing System^{®A} gives you the assurance that all of your Owens Corning Roofing components are working together to help increase the performance of your roof — and to enhance the comfort and enjoyment of those who live beneath it.



SEAL.

SELF-ADHERED ICE
& WATER BARRIER
SYNTHETIC UNDERLAYMENT



DEFEND.

STARTER SHINGLES
LAMINATE SHINGLES
HIP & RIDGE SHINGLES



BREATHE.

INTAKE VENTS
EXHAUST VENTS

+ COMFORT.

PINK® FIBERGLAS™
BLOWN-IN
ATTIC INSULATION

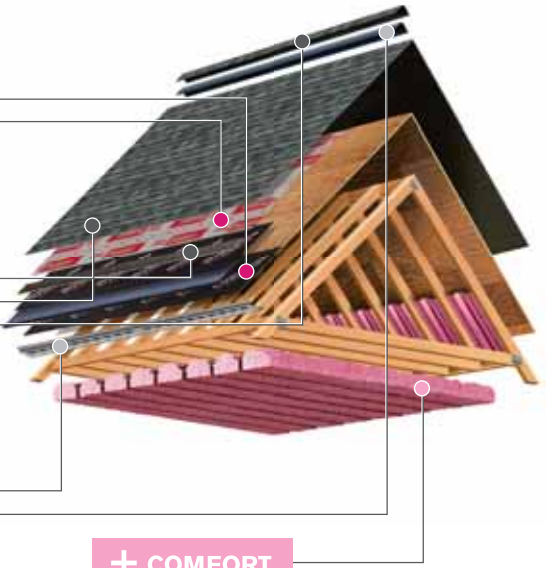

OWENS CORNING ROOFING AND ASPHALT, LLC
ONE OWENS CORNING PARKWAY
TOLEDO, OHIO, USA 43659

1-800-GET-PINK®
www.owenscorning.com/roofing

Pub. No. 10020940-C, Printed in U.S.A. October 2019.
THE PINK PANTHER™ & © 1964–2019 Metro-Goldwyn-Mayer Studios Inc.
All Rights Reserved. The color PINK is a registered trademark of Owens Corning.
© 2019 Owens Corning. All Rights Reserved.



For patent information, please visit www.owenscorning.com/patents
SureNail® Technology is not a guarantee of performance in all weather conditions.
SureNail® Technology is available only on Owens Corning® Duration® Series Shingles.
2015 SureNail® Technology Performance Comparison Contractor Survey, December, 2015

^A Excludes non-Owens Corning Roofing products such as flashing, fasteners, pipe boots and wood decking.