

Department of Housing and Urban Development  
Office of Public and Indian Housing



# HUD MAINTENANCE GUIDEBOOKS

**GUIDEBOOK**



**ROOF AND WATERPROOFING  
MAINTENANCE**

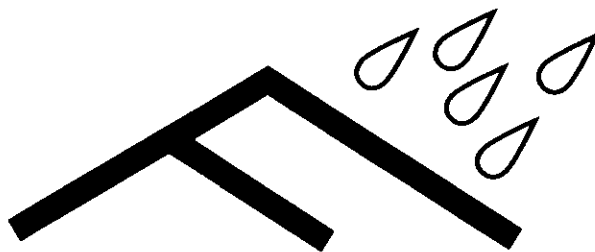

September 1995

# **HUD MAINTENANCE GUIDEBOOKS**

## **GUIDEBOOK FIVE**

### **ROOF AND WATERPROOFING MAINTENANCE**

Department of Housing and Urban Development  
Office of Public and Indian Housing

September 1995

HUD Maintenance Guidebook Five  
Roof and Waterproofing Maintenance

DISCLAIMER

Although the information presented in the HUD Maintenance Guidebooks is set forth in good faith and believed to be accurate, neither the Department of Housing and Urban Development (HUD) nor CHK Architects and Planners, Inc. (CHK) makes any representation or warranty as to the completeness or accuracy thereof. Information is supplied on the condition that the user of the HUD Maintenance Guidebooks will make their own determination as to suitability for their purposes prior to its use. The user of the HUD Maintenance Guidebooks must review and modify as necessary the suggested material from the guidebooks prior to incorporating them into a project.

In no event will HUD or CHK be responsible for damages of any kind resulting from the use or reliance upon information or the policies, materials, products, systems, or applications to which the information refers. Nothing contained in the guidebooks is to be construed as a recommendation or requirement to use any policy, material, product, process, system or application and neither HUD nor CHK makes any representation or warranty express or implied. NO REPRESENTATION OR WARRANTY, EITHER EXPRESSED OR IMPLIED OF FITNESS FOR A PARTICULAR PURPOSE IS MADE HEREUNDER WITH RESPECT TO INFORMATION OR THE POLICIES, MATERIALS, PRODUCTS, SYSTEMS, OR APPLICATIONS TO WHICH THE INFORMATION REFERS.

In addition to and not with standing the above, in no event shall HUD or CHK be liable for any consequential or special damages or for any loss of profits incurred by the user or any third party in connection with or arising out of use of the HUD Maintenance Guidebooks.

END OF DISCLAIMER

**TABLE OF CONTENTS  
FOR  
HUD MAINTENANCE GUIDEBOOKS  
GUIDEBOOK V - ROOF AND WATERPROOFING MAINTENANCE**

**AUGUST 1994**

<b>CHAPTERS</b>	<b>Pages</b>
<b>1</b>	<b>GENERAL</b>
	A Purpose and Scope 1-1
	B Use of Guidebook 1-1
	C Importance of Timing and Inspections 1-1
<b>2</b>	<b>SAFETY</b>
	A General 2-1
	B OSHA Regulations 2-1
	C Weather Conditions 2-1
	D Equipment 2-1
	E Hazard Communication 2-2
	F Storage and Handling of Roofing Materials 2-2
	G Material Safety Data Sheet (MSDS) 2-2
	H Personal Safety 2-2
	I Fire Protection 2-4
	J Sloped-Roof Safety 2-5
	K Ladders 2-5
	L Scaffolds 2-6
	M Heating and Handling of Hot Bituminous Materials 2-6
	N Torching Safety 2-7
	O Single-Ply Systems 2-8
	P Asbestos-Containing Roofing Materials 2-8
<b>3</b>	<b>ROOF AND WATERPROOFING MAINTENANCE MANAGEMENT</b>
	A General 3-1
	B Establishment of Roof and Waterproofing Maintenance Program 3-1
	C Historical Data File 3-2
	D Warranties and Repairs 3-2
	E Inspection Techniques and Equipment: General Overview 3-3
	F Repair Versus Replacement—The Options 3-4
	G Repair Versus Replacement—The Cost Analysis 3-7
	H Hiring a Roofing Contractor 3-8

<b>4</b>	<b>INSPECTION</b>	
	A General	4-1
	B Preparation for Inspection	4-1
	C Systematic Inspection of the Structure, Roofing, and Waterproofing Systems	4-4
	D The First Phase: Interior Inspection	4-4
	E The Second Phase: Exterior Inspection	4-5
	F The Third Phase: Roof Inspection	4-8
	G The Fourth Phase: Waterproofing Inspection	4-17
	H The Fifth Phase: Analysis and Recommendations	4-18
	I The Sixth Phase: Additional Testing	4-18
	J Locating Leaks	4-18
	K Water-Testing	4-18

<b>5</b>	<b>MAINTENANCE AND REPAIR</b>	
	A Introduction	5-1
	B Maintenance	5-1
	C Emergency Repairs	5-2
	D Repair of Built-up Roof Membranes	5-5
	E Modified-Bitumen Roof Membranes	5-13
	F Roll Roofing	5-15
	G Metal Roofs	5-16
	H Slate, Tile, and Other Rigid Roofing Shingles	5-19
	I Asphalt Shingles	5-21
	J Counterflashing	5-23
	K Valleys	5-25
	L Parapets	5-26
	M Drains, Gutters, and Downspouts	5-28
	N Miscellaneous Penetrations and Roof-Top Equipment	5-29
	O Insulation	5-31
	P Deck Repairs	5-31
	Q Waterproofing	5-32

<b>GLOSSARY</b>	G-1
-----------------	-----

<b>BIBLIOGRAPHY</b>	B-1
---------------------	-----

**APPENDIX A - HISTORICAL ROOFING RECORD**

**APPENDIX B - ROOF INSPECTION FORM**

**APPENDIX C - ADDITIONAL RESOURCES**

**END OF TABLE OF CONTENTS**

# MAINTENANCE GUIDEBOOK V ROOF AND WATERPROOFING MAINTENANCE

## CHAPTER ONE - GENERAL

### SECTION A PURPOSE AND SCOPE

The purpose of this Guidebook is to provide technical guidance and assistance to personnel responsible for planning and inspecting roofs and waterproofing and carrying out the maintenance and repair of roof and waterproofing systems of the properties of Public Housing Agencies and Indian Housing Authorities (jointly referred to as HAs).

### SECTION B USE OF GUIDEBOOK

This Guidebook should be read in its entirety by all HA personnel responsible for managing, inspecting, and maintaining roofs and waterproofing of HA developments, and should be used while carrying out such activities. It should also be useful for training HA staff, for assisting HAs in the process of deciding whether to replace a roof or continue to make repairs, and for deciding when to seek outside assistance.

### SECTION C IMPORTANCE AND TIMING OF INSPECTIONS

#### 1. GENERAL

The intent of performing timely and regularly scheduled inspections of roof and waterproofing systems is to identify conditions requiring maintenance, repair, or replacement so that corrective action can be taken. As a minimum, such systems should be inspected annually as required by the Public Housing Management Assessment Program (PHMAP) of the Department of Housing and Urban Development (HUD), and the defects corrected as necessary. Deficient conditions observed during inspections may or may not be contributing to active leaks. If the inspections are not completed, however, these conditions could easily result in serious problems before they are noticed as leaks or other defects. Early discovery and correction of minor defects averts major repairs and extends the service life of the roof and waterproofing system.

#### 2. LOW-SLOPE ROOFING SYSTEMS—INSPECT TWICE A YEAR

All low-slope roof systems should be inspected by a qualified technician twice a year, once in the spring and once in the fall. If only one inspection a year is made, it should be done in the spring.

### **3. SPECIAL INSPECTIONS**

Special inspections should be performed after major storms and after any construction on or adjacent to the roof.

### **4. STEEPLY-SLOPED ROOFS—INSPECT ONCE A YEAR**

Steeply-sloped roof systems should be inspected once a year. The drainage of steep sloped roofs should be inspected twice a year, once in the spring and once in the fall. Such inspections should be performed concurrently with maintenance work, such as removing leaves and debris from the gutters, to save time. Special inspections should also be made after major storms.

### **5. WATERPROOFING SYSTEMS**

Waterproofing systems such as stucco, masonry pointing, sealant joints, and foundation waterproofing should be inspected every year, and when leaks occur.

**END OF CHAPTER ONE**

# MAINTENANCE GUIDEBOOK V ROOF AND WATERPROOFING MAINTENANCE

## CHAPTER TWO - SAFETY

### SECTION A GENERAL

Roof work, by its nature, ranks high in the incidence of accidents. Therefore, safety and accident-prevention measures should be part of the roof maintenance and repair program. Complete coverage of safety precautions is beyond the scope of this Guidebook. However, the observation of the following safety suggestions will go a long way toward preventing common accidents.

### SECTION B OSHA REGULATIONS

Occupational Safety and Health Administration (OSHA) regulations regarding protection of the individual should be followed as part of all roofing and waterproofing repair work. Particular attention should be given to requirements for protection required around skylights, other roof openings, and at roof edges. Many states have OSHA-approved job-safety and health plans that would take precedence over the federal standards. Construction Standards are found at 29CFR 1926 (Code of Federal Regulations). Contact OSHA at US Department of Labor, 200 Constitution Avenue, NW, Washington, DC 20001 (Phone 202/219-8148) for copies of the regulations and information on state authority.

### SECTION C WEATHER CONDITIONS

Roofing work should be performed only during dry weather.

### SECTION D EQUIPMENT

The following applies to all tools and equipment used in roofing and waterproofing:

- Tools and equipment should be in safe and serviceable condition and inspected periodically.
- Equipment with moving parts should be operated with guards in place.
- Equipment should not be repaired while it is in operation.
- Electrical equipment and extension cords should be equipped with a ground-fault interrupter.



## **SECTION E HAZARD COMMUNICATION**

Maintain all records required by OSHA (OSHA 200 logs and safety training, for example), and ensure that all employees are properly trained in the OSHA Hazard Communication Standard.

- Material Safety Data Sheets (MSDSs) should be kept current.
- A written Hazard Communication Program should be both developed and available to employees and management.
- Materials should be properly labeled.
- A list of hazardous chemicals used should be provided.

## **SECTION F STORAGE AND HANDLING OF ROOFING MATERIALS**

A few caveats on the storage and handling of roofing materials are the following:

- Segregate materials by kind and size and store neatly. If they are stored on the roof, place them in neat, orderly piles that are safe against falling, blowing, and other hazards. Avoid overloading roofs.
- Place warning signs in daylight and red lights at night on and around materials stored in walkways, driveways, or streets. Such stored materials should not hinder traffic.
- Cover and protect materials against damage from the weather, theft, and vandalism.

## **SECTION G MATERIAL SAFETY DATA SHEET (MSDS)**

A typical Material Safety Data Sheet (MSDS) is a product summary prepared by the product's manufacturer. It describes the material and lists the manufacturer's identity, location, and phone number so that anyone needing more information can call. The MSDS will inform interested individuals if the product poses a serious health hazard and whether there are any special precautions that should be taken in the use of the product. The MSDSs should be collected for maintenance materials kept in stock by the HA and used during repair and replacement work. The MSDS sheets should be kept current. Request a new MSDS with each shipment of material from the manufacturer.

## **SECTION H PERSONAL SAFETY**

### **1. HARD HATS**

Hard hats meeting ANSI standards should be worn at all times where there is a possible danger of head injury from impact, falling or flying objects, or from electrical shock or burns.

## **2. EYE PROTECTION**

When operations present the potential for eye or face injury from physical, chemical, or radiation agents, eye and face protection equipment should be worn. The equipment should be labeled or otherwise indicate that it meets ANSI specifications Z87.1-1989 "Practice for Occupational and Educational Eye and Face Protection."

## **3. FACE SHIELDS**

Face shields meeting ANSI standards should be used by a kettleman loading the kettle or withdrawing bitumen.

## **4. SUN SCREEN**

Barrier creams with high-level sun screen should be used.

## **5. HEARING PROTECTION**

Utilize hearing protective devices where appropriate.

## **6. GLOVES**

Gloves with snug-fitting cuffs that extend up under shirt sleeves should be worn at all times. The type of glove used depends on the type of work being performed.

## **7. SHIRTS**

Shirts should be long-sleeved and should be buttoned at the cuff around the gloves. Shirt tails should be tucked in and the shirt should be buttoned up.

## **8. PANTS**

Pants made of sturdy fabric should be full-length, cuffless, and fit snugly around the boots.

## **9. BOOTS**

Safety boots and shoes are available in all sorts of styles—from gym shoes to dress shoes—with the ANSI approval code. It is vital to choose the proper protective footwear to suit the job.

## **10. RESPIRATORS**

When operations present the potential for exposure to air-borne contaminants, use respiratory protection. Check MSDS for contaminant to which exposure may occur during the work. Use devices indicating that they are acceptable to the US Bureau of Mines for specific contaminants exposure. Comply with OSHA respiratory standards which are found at 29CFR 1910.134 for general industry and 1926.103 for construction.

## **11. LIFELINES**

Lifelines should be used when work places are more than 25 feet above the ground or other surfaces; however, it is recommended that safety belts and lifelines be used at lower heights as well. Lifelines and lanyards should be a minimum 3/4-inch diameter and should be attached to safety belts with a breaking strength of 5,400 pounds. Lifelines and lanyards should be anchored to a structural member capable of supporting 5,400 pounds of dead weight.

## **12. FIRST-AID KITS**

A first-aid kit should be on the job at all times along with a current list of emergency phone numbers. Employees should be informed of their location.

## **SECTION I FIRE PROTECTION**

Appropriate, operable fire extinguishers should be on the job and accessible on the roof and near any stored flammable products or open-flame operations. Locate a fire extinguisher at the kettle and within easy reach of wherever hot material is applied near combustible construction. Check MSDS for proper type of fire extinguisher for hot material being applied.

- Flammable materials should be kept only in UL- or FM-approved safety containers. Other liquids should be kept in clearly marked containers.
- Kettles and tankers should have properly fitting lids, be kept in good condition, and be equipped with temperature gauges in good working condition.
- Kettle temperatures should be kept below the bitumen flash point. Loading and handling of bitumens and operation of heating equipment should be done in accordance with manufacturer's recommendations.
- Never direct burner toward fuel tank, LP bottle, hose, or flammable material.

## **SECTION J SLOPED-ROOF SAFETY**

Methods of assuring safety while working on roofs depend, to some extent, on the slope of the roof in question and the extent of work to be performed. Perimeter protection should be provided on sloped roofs with a ground-to-eave height greater than sixteen feet when extensive repair work will be performed.

For roof slopes greater than 4:12, the following information taken from OSHA standard 1926.451(u) Roofing Brackets applies:

- Roofing brackets should be constructed to fit the pitch of the roof as illustrated in Figure 2-1.
- Brackets should be secured in place by nailing when possible without penetrating the roof coverage. When it is impractical to nail brackets, rope supports can be used. Rope supports should consist of first-grade rope of at least 3/4-inch diameter, or equivalent.
- A catch platform should be installed below the working area of roofs with a height of more than sixteen feet from the ground to the eaves and with a slope greater than 4 inches in 12 inches unless there is a parapet. The platform should extend two feet beyond the protection of the eaves and have a guardrail, midrail, and toeboard. A platform is not necessary when employees engaged in work upon the roof are protected by a safety belt attached to a lifeline.
- Wear rubber-soled footwear on pitched roofs.

## **SECTION K LADDERS**

The following are some basic elements of a safety program involving work on ladders. For more detailed information on ladder safety refer to OSHA 29CFR Subpart X of 1926.1050.

- Inspect and test all ladders to determine whether they are strong enough to carry the intended loads.
- Construct wooden ladders of straight-grained materials free from defects. Apply slip-resistant material to ladder rungs. Do not paint wooden ladders, since paint may serve to conceal defects.
- Mark metal ladders with signs cautioning use around and against electrical wires and equipment.
- Provide ladders with non-slip bases and fasten at top when possible.
- Place foot of ladder one-fourth of its length away from the vertical plane of its top support.
- Extend ladders leading to landings or walkways at least 36 inches above the landing. Fasten or tie-off to prevent slipping.
- Do not splice ladders to provide longer sections, unless specifically designed for such use. Avoid splicing ladders whenever possible.
- Always face the ladder when ascending or descending the ladder.
- Ladder jacks should have positive fastening devices and should be used only on stable ladders.
- Construct "chicken" ladders or crawling boards at least 10 inches wide and 1 inch thick, with 1 x 1-1/2 inch cleats. The cleats should be equal in length to the width of the board and spaced at equal

intervals not to exceed 24 inches. Nails should be driven through and clinched on the underside. Crawling boards should extend from the ridge pole to the eaves, and should be secured to the roof with ridge hooks or other effective means so they cannot become loose. A fastened lifeline of 3/4-inch rope or equivalent should be strung beside each crawling board for a hand hold.

- Maintain clean areas around the top and bottom of ladders.

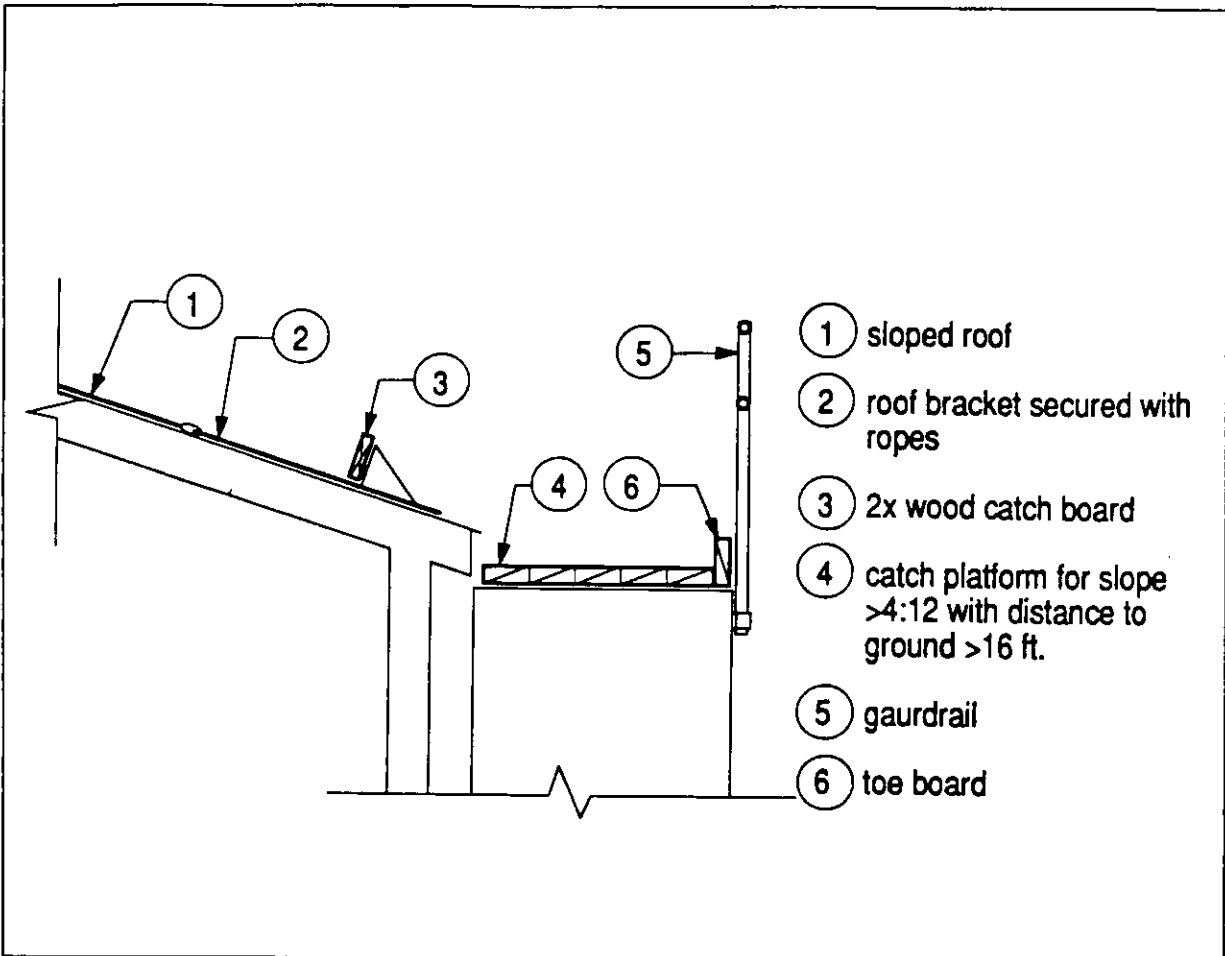

Figure 2-1

## **SECTION L SCAFFOLDS**

Do not exceed the rated safe carrying capacity of scaffolds, and protect edges of all scaffolding with railings and toe boards. Do not use scaffolds for storage of materials except those currently being used. Clean scaffolds daily of all rubbish. Scaffolds should comply with OSHA's standards in 1926.451.

## **SECTION M HEATING AND HANDLING OF HOT BITUMINOUS MATERIALS**

Heating kettles should be mounted on a firm, level, noncombustible foundation and be kept at least three feet from combustible materials. Kettles should be constantly attended and adequately protected from

personnel, vehicles, and other equipment. The kettles should have a close fitted lid that can be closed immediately if the heated material flames. Thermometers and temperature control devices should be used to prevent overheating of bitumens. Material must be thoroughly dry before it is added to heated contents of kettles. Add material by sliding it into the kettles and not by dropping it.

Do not thin or dilute material being heated with flammable substances. Shut down burners when refueling or if heated material bursts into flames. In hoisting material and handling hot substances, be sure that hoisting gear is strong enough to carry loads, is securely braced, and does not endanger workmen nearby or below. Require all persons handling hot substances to use proper foot and leg protection, goggles, gloves, and other personal protective equipment.

## **SECTION N TORCHING SAFETY**

The following general procedures should be followed whenever torches are used:

- Torching equipment should be in good working condition.
- Hand-held torches and torching trollies should have an adjustable pilot light and an adjustable valve that controls flame size.
- Keep cylinders fastened securely in an upright position when being stored or transported, and be sure the container valve is closed with safety cap or collar in place.
- Cylinders should not be dropped or allowed to strike each other and should be checked before each use for rust and dents.
- Cylinders should be moved by means of a hand truck. If absolutely necessary to move them by hand, roll them on the bottom edge, never drag them.
- When in doubt, always assume that cylinders are full and handle them accordingly.
- The hose between the torch and the fuel tank should be at least 25 inches long and have the Underwriters Laboratory (UL) approval.
- Check hose prior to use for cleanliness, cuts, cracks, or worn places. Replace immediately if any of these are present.
- The pressure regulator and pressure gauge allow for an even flow of gas and should also have the UL approval.
- Tanks should be sized to meet the requirements of the burner equipment.
- A lit torch should never be left unattended.
- All combustibles should be properly disposed.
- Never torch to a combustible surface.
- At the end of the day, turn off the torch, then the tanks, and then bleed the line of excess gas.
- The foreman should perform at least a one-hour fire watch.

## **SECTION O SINGLE-PLY SYSTEMS**

Ensure that confined work areas are properly ventilated, and allow no smoking around any single-ply products.

## **SECTION P ASBESTOS-CONTAINING ROOFING MATERIALS**

Asbestiform minerals are still used in roofing materials to add durability and strength to them. Asbestos-Containing Roofing Materials (ACRM) may be found in nearly all types of roofing installations. Roofing cements which contain asbestos should be avoided. ACRM may include:

- Flashings,
- One or more layers of built-up roofing systems,
- Shingles,
- Roofing tar paper,
- Vapor-barrier material,
- Roofing and flashing cements,
- Miscellaneous materials used for patching.

HAs should be satisfied that the materials purchased for roofing repairs do not contain asbestos.

**END OF CHAPTER TWO**

# **MAINTENANCE GUIDEBOOK V**

## **ROOF AND WATERPROOFING MAINTENANCE MANAGEMENT**

### **CHAPTER THREE - ROOF AND WATERPROOFING MAINTENANCE MANAGEMENT**

#### **SECTION A GENERAL**

Roof systems are complex, waterproofing assemblies, designed to protect the building and its contents from water infiltration and damage. Most roofs include insulation for energy conservation and to serve as a substrate for drainage slopes and roof membrane. Roof-mounted mechanical equipment has special curbing and flashing to waterproof the installation. Parapet walls and pipe penetrations require flashing or booting. All these items should be maintained, or premature failure can occur. Some of the causes of premature failure include the following:

- Lack of roof maintenance;
- Improper or incomplete roof design/construction;
- Incorrect use of materials;
- Improper material storage during the original installation or subsequent repairs;
- Extreme climatic conditions—wind, rain, hail, snow, ice;
- Improper modifications or attachments;
- Inadequate drainage;
- Damage resulting from other construction and vandalism;
- Foot traffic;
- Installation of antennae by residents;
- Foreign objects.

#### **SECTION B ESTABLISHMENT OF ROOF AND WATERPROOFING MAINTENANCE PROGRAM**

The causes of roof failures mentioned above, and others, highlight the fact that all roof systems require some degree of maintenance to ensure that the roof does not fail prematurely. Small defects should be corrected before they become more extensive and expensive repairs. An effective roof-maintenance program involves the implementation of scheduled inspection and necessary corrective action.

The roof inspection and maintenance program should be aided by a periodically updated Historical Data File.



## **SECTION C HISTORICAL DATA FILE**

Each HA building should have a Historical Data File (HDF), which should be created when the roof is installed. If HDFs were not created initially, they should be created as soon as possible afterwards.

The HDF generally contains the following:

- As-built drawings and specifications showing the locations of penetrations, roof-top equipment, and flashing;
- Material manufacturers' brochures, specifications, and application instructions;
- All inspection checklists, including reference drawings, reports, and correspondence;
- Names, addresses, and telephone numbers of roofing and waterproofing contractors who are responsible for the initial installation and any subsequent repairs;
- Warranty information, including the following:
  - Date of acceptance of the roof installation;
  - Applicator's warranty and expiration date;
  - Manufacturer's warranty, expiration date, and terms (make particular note of owners' responsibilities and acts that can void warranty);
- Record of any changes made to the roof, including addition of mechanical equipment;
- Records of past problems and corrective actions—for example, repair work orders and leak reports;
- A Historical Roofing Record (see Appendix A) to be kept on top of the file. This will provide a ready reference for important information relative to the "as-built" roof construction;
- Prints of reproducible plan and blank roof-inspection forms (see Appendix B) for use in subsequent inspections.

## **SECTION D WARRANTIES AND REPAIRS**

### **1. WARRANTY**

One of the most important things the HA should do is to obtain, read, and understand the manufacturer's warranty for the roof system installed. A warranty is a contract between the HA and the manufacturer which can be voided if its stipulations are violated. Some common occurrences which may result in a voided warranty include, but are not limited to, the following:

- Neglect of roof system by not performing inspection, repairs, and routine maintenance in a timely manner (having a warranty does not mean that the HA can forget about the roof);
- Failure of the HA to notify the manufacturer of leaks in the roof system in a timely manner;
- Failure of the HA to notify the membrane manufacturer of work required to repair damage or to add roof-top equipment;
- Failure to have permanent repairs or maintenance performed in accordance with

manufacturers' instructions such as:

- Use of materials not manufactured by the warranting manufacturer, or use of incompatible material for repair;
- Work performed by contractor not approved or authorized by manufacturer to perform such work.

## **2. REPAIRS**

The importance of having repairs made by qualified contractors in accordance with the membrane manufacturer's recommendation, whether or not the roof is under warranty, cannot be overstressed. Use of incompatible materials can result in accelerated deterioration of some membranes and may result in short-lived repairs. Only the most basic repairs should be performed by HA staff unless they are skilled and properly trained roof mechanics.

## **SECTION E INSPECTION TECHNIQUES AND EQUIPMENT: GENERAL OVERVIEW**

### **1. VISUAL INSPECTION**

Roofing and waterproofing inspections are normally visual, which enables the inspector to readily identify the results and sources of the defects. Visual inspections, however, are not always conclusive and testing is sometimes necessary.

### **2. WATER-TESTING**

Water testing is a leak detection method that uses a garden hose to help identify leak sources in both roofs and waterproofing. The roof is flooded, or the flashing and masonry are sprayed, until water appears at the interior of the building. Water-testing requires practice and patience, has some distinct disadvantages, such as property damage if not properly conducted, and may not be effective for every roof system, particularly re-cover roof systems.

### **3. NONDESTRUCTIVE TESTING**

There are several forms of nondestructive technology that can assist the HA in determining the condition of the roof. Most HAs, however, have no ready access or the knowledge to use the specialized equipment required. The following information is provided about the availability and use of nondestructive testing methods. When extensive repairs are required or replacements are

considered, the HA should consider contracting for one of the test methods listed below. All methods produce data that must be correlated with test cuts in the roofing system.

**a. Infrared (IR) Thermography**

IR equipment can locate wet insulation by detecting the thermal differences that occur between areas of wet and dry insulation during certain times of the day. Thermal differences (anomalies) detected by IR equipment produce an image on the instrument monitor. Moisture in wet areas normally shows as a light-shaded area; dry insulation is indicated by dark-shaded areas. The IR image is formed by energy radiating from the various materials and should be interpreted by a skilled operator. Due to interference from other forms of radiation during daylight hours, the IR scan is best conducted at night.

**b. Nuclear Moisture Meter**

The nuclear moisture meter detects moisture in the insulation by measuring the difference in densities of hydrogen ions between the wet and dry areas of insulation. Readings are taken in a grid pattern, and through statistical analysis and interpretation of the readings, a contour plot is developed which outlines the wet areas.

**c. Capacitance Meter**

The capacitance meter measures the differences in dielectric constants that occur between wet and dry areas. The application and interpretation of results is similar to that of the nuclear moisture meter.

## **SECTION F REPAIR VERSUS REPLACEMENT—THE OPTIONS**

### **1. GENERAL**

Every roof system ultimately requires replacement. While the main purpose of this guidebook is to serve as a guide for extending the useful life of roofs by proper maintenance and repair methods, it is of equal importance to determine when such treatments are no longer economically feasible and reroofing is necessary. The alternatives for correcting defects in roof systems include the following:

- Preventive maintenance;
- Repairs;
- Re-cover roofing;
- Replacement.

The decision to repair or replace a roof is based upon several factors, including existing condition of the roof, economics, and availability of in-house resources.

## **2. PREVENTIVE MAINTENANCE**

Preventive maintenance consists of scheduled procedures for correcting minor deficiencies to extend the life of the roof system like periodic (semi-annual) inspections, replacing defective or missing shingles, removing leaves and foreign objects from gutters, and ensuring that deficiencies noted during inspections are corrected.

## **3. REPAIRS**

Roof damage resulting from weather conditions, abuse, and other causes are corrected through repairs. The basic techniques for accomplishing repairs for different roof systems are contained in Chapter Four of this guidebook. The repairs should be completed in accordance with good roofing practice and with materials compatible and designed for use with the type of roof system being repaired. The repairs should not be performed when the roof is wet or when precipitation is predicted. Most repairs can be performed by HA forces. There are cases, however, when contract work is warranted. The decision to perform an extensive and costly roof repair should be based on an economic analysis comparing the life-cycle cost of repair versus replacement, and availability of funds. The repair should correct both the cause of the problem and the deficiency itself, otherwise the deficiency will recur.

## **4. RE-COVER ROOFING**

Re-cover roofing is a new roof system placed over the top of an existing roof. This alternative is not suitable for every condition; therefore, it should be avoided if at all possible. The following conditions should be met, and disadvantages and advantages considered, before deciding to install a recover roof.

- The insulation, if any, must be dry. Insulation with entrapped moisture must be located, removed, and replaced with similar dry materials. Generally, nondestructive moisture surveys are used in determining the extent of wet insulation.
- The existing roof-system components must be well attached to each other and to the structural deck. Unattached materials in localized areas should be mechanically fastened to the structural deck.
- The surface of the existing membrane should not have excessive blisters, patches, ridges, fishmouths, membrane irregularities, or abrupt changes in elevation.
- Existing flashing conditions should accommodate the added thickness of new roofing without

extensive work.

- The existing structure must be able to safely carry the added weight of the re-cover roofing system.
- The existing roof cannot be a previously installed re-cover roof.

**a. Advantages**

The advantages of re-cover roofing include the following:

- It is less expensive than complete tear-off and replacement of the existing roof;
- Unless the required surface preparation is unusual, construction time is shorter than for tear-off and replacement;
- The thermal value of the existing roof is kept, since it becomes part of the system.
- Roof insulation can be added to provide greater insulating values or better slope conditions; however, the amount of additional insulation will be limited by existing flashing heights.

**b. Disadvantages**

The disadvantages of re-cover roofing include the following:

- Much lower life expectancy than for tear-off and replacement;
- Preparation of the existing roof system might become more extensive and expensive than anticipated, requiring contract change orders.
- A defect, such as nonattachment or moisture within the existing system, may adversely affect the performance of the new roof.
- If insulation is added over the existing system, the existing membrane functions as a vapor barrier, and condensation problems may develop.

In general, after all preparations required for re-cover roofing are made, better and more long-term results can be accomplished by repairing the existing roof, often at a much lower cost.

## **5. REROOFING BY REMOVAL AND REPLACEMENT**

At the end of their lives, shingle roofs become excessively brittle and built-up, and other flat-roof systems show acute signs of deterioration, warranting the need for complete replacement. There are times prior to this, however, when due to premature deterioration, the advantage of complete roof replacement needs to be considered.

### **a. Advantages**

The advantages of removal and replacement include the following:

- Exposure of structural deck when roof coverage is removed permits a close inspection and repair of defects;
- No wet insulation remains in the roof;
- Roof insulation can be added for increased insulating value to meet current requirements or for improved slope for positive drainage;
- Flashing problems can be corrected.

### **b. Disadvantages**

The disadvantages of removal and replacement include the following:

- The construction time is longer than for repairs or re-cover roofing.
- Dry insulation removed is wasted. However, under certain conditions, the existing insulation can be reused.

Several factors need to be considered before a decision is made to replace a roof, such as its condition, age, and the frequency and cost of previous repairs. The latter data should be found in the Historical Data File.

## **SECTION G REPAIR VERSUS REPLACEMENT—THE COST ANALYSIS**

Generally, cost estimates and life-cycle cost comparisons are used for determining if the roof should be repaired or replaced. The following is one of several methods for life-cycle costing techniques.

### **1. DETERMINE FEASIBILITY**

First, decide which optional methods are technically feasible for a given roof. The HA should evaluate the roof condition, extent of leaks, environmental factors (asbestos), and anticipated costs. Depending on the size of the HA and circumstances, it may be necessary to contract out such an analysis. The following options should be considered:

- Accomplish repairs now, reroof at a later date.
- Reroof by removal and replacement now, including provisions for upgrading the existing system by adding insulation, improving drainage, removing abandoned equipment, installing new curbs, and installing new flashing.
- Reroof by removal and replacement now, with a different type of system, such as single-ply, or modified bitumen.

- Install a re-cover roof. Consider the disadvantages of not recognizing bad conditions of the existing roof below the re-cover roof membrane.
- Replace problematic flat roof with pitched roof.

## **2. PREPARE COST ESTIMATE**

Prepare a cost estimate for each option. All aspects of each option should be considered. For instance, special handling equipment (cranes, hoists, chutes), or extraordinary substrate preparation for a particular system. (Some systems require complete, 100 percent removal of the existing roof system, such as mopped-down vapor barriers, while other systems require removal of only "loose" material.)

## **3. DEVELOP LIFE-CYCLE COSTS**

Develop a life-cycle cost for each option considered by extending the costs over the expected life of a new roof (typically 20 years). The cost of all options should be analyzed over the same period including anticipated additional repairs for other than complete replacement options. Such additional repairs may include recoating smooth-surfaced membranes, and other anticipated repairs for each type of system.

The life expectancy of repairs should be based upon the existing condition of a roof to be repaired, the extent of repairs to be made, and the understanding that additional repairs may be required later. Life expectancy of a re-cover roof should be based upon thorough knowledge of the existing roof, the manufacturer's literature, and actual field experience with similar re-cover roofs.

All life-expectancy figures require sound engineering judgment and thorough knowledge of the existing conditions over which the repair, re-cover, or replacement roof is considered.

## **4. COMPARE OPTIONS**

Next, compare the options and decide which one is the most economical to choose. The final selection should be made on the basis of economy and availability of necessary funds.

## **SECTION H HIRING A ROOFING CONTRACTOR**

The National Roofing Contractors Association (NRCA) publishes a bulletin entitled "Insist on a Roofing Professional." The HA may contact NRCA, 10255 West Higgins Road, Suite 600, Rosemont, Illinois 60018 (Phone 708/299-9070) for a copy of the bulletin, when considering hiring a roofing contractor.

The following areas should be considered when evaluating roofing contractors:

- Experience with specified roof system;
- Well-established track record (contact past clients for references);
- Insurance and bonding capacity;
- Financial solvency.

**END OF CHAPTER THREE**



# MAINTENANCE GUIDEBOOK V ROOF AND WATERPROOFING MAINTENANCE

## CHAPTER FOUR - INSPECTION

### SECTION A GENERAL

Roof and waterproofing systems are comprised of many parts that work together to provide a watertight barrier between the exterior and interior of the building. The partial or complete failure of any one component may result in failure of the entire system.

The visual inspection of the roof and waterproofing systems includes an evaluation of:

- Interior components of the building associated with the roof and waterproofing systems such as ceiling, and walls;
- Exterior components, including the facade, parapets, fascias, and drainage;
- The roof surface, including flashing, drainage, penetrations, parapets, and edge details;
- Waterproofing system, including sealant joints, mortar joints, building expansion joints, exposed flashing, and surface drainage.

Typical roof components are illustrated in Figures 4-1 and 4-2.

The inspection and repair of roof and waterproofing systems should be accomplished by trained personnel knowledgeable in:

- The basic make-up of the system being inspected;
- Identifying the various defects;
- Making recommendations to accomplish the necessary repairs;
- Recognizing when repairs are beyond the HA's ability.

### SECTION B PREPARATION FOR INSPECTION

Prior to inspection, the Inspector should review the Historical Data File, especially the most recent inspection report and any related work orders. Leaks reported since the last inspection should be noted on the inspection roof plan. The Inspector should take the following items with him or her for conducting the inspection:

- Blank inspection report form;
- Roof plan with leak locations noted;
- Copy of last inspection report;

## LEGEND

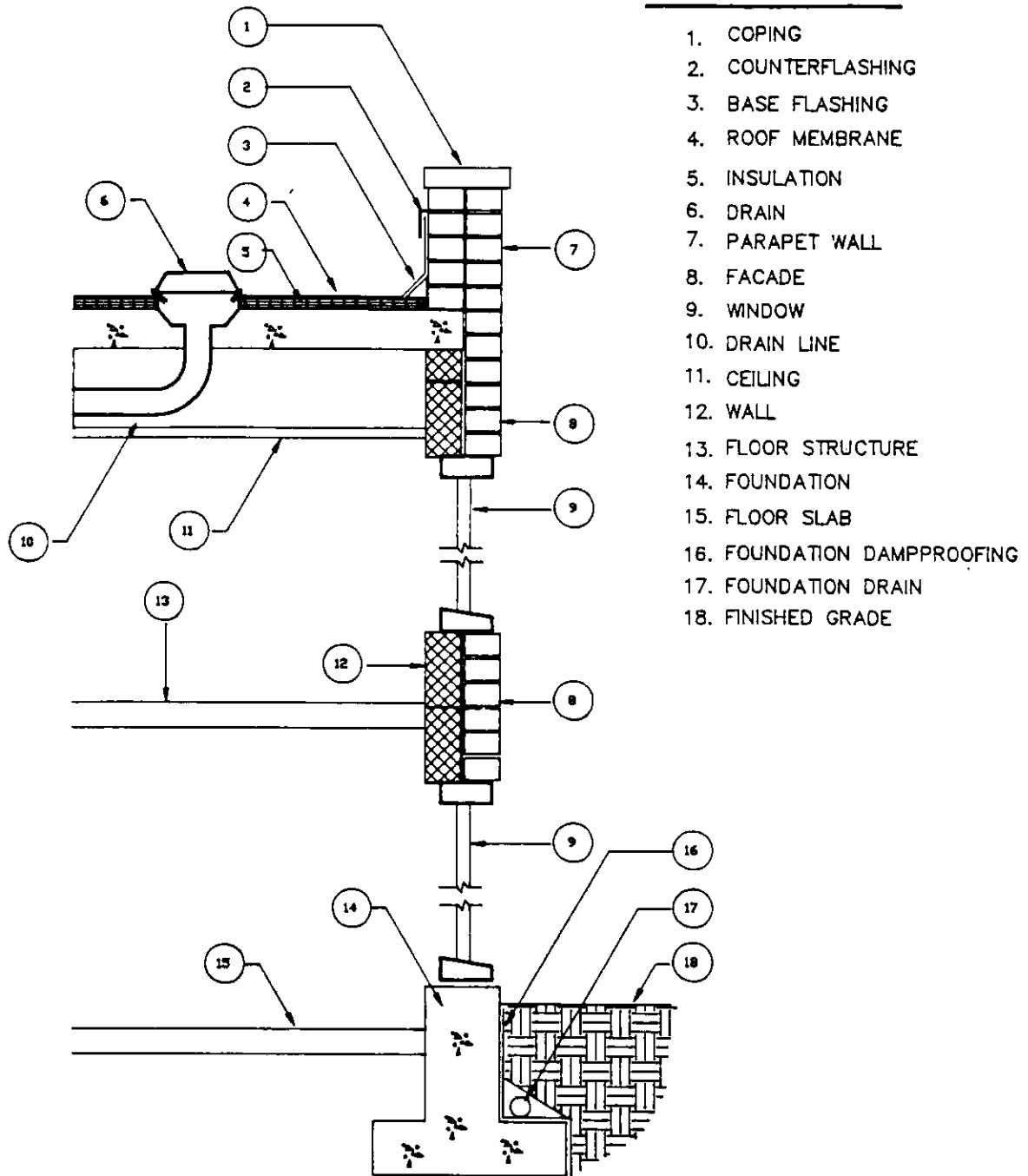
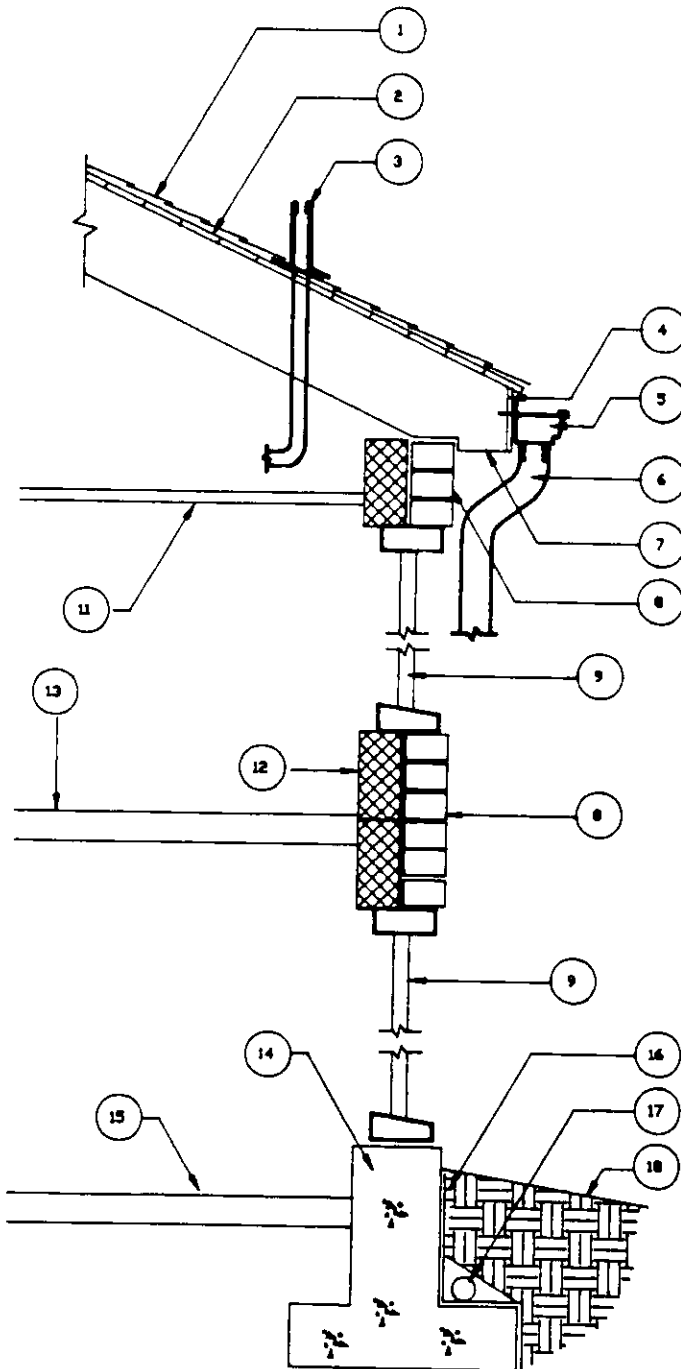

Figure 4-1: Building Components—Flat-Roofed Buildings

## LEGEND



1. SHINGLE ROOFING
2. ROOF DECK
3. PIPE PENETRATION
4. FASCIA
5. GUTTER
6. DOWNSPOUT
7. SOFFIT
8. FACADE
9. WINDOW
10. NOT USED
11. CEILING
12. WALL
13. FLOOR STRUCTURE
14. FOUNDATION
15. FLOOR SLAB
16. FOUNDATION DAMPPROOFING
17. FOUNDATION DRAIN
18. FINISHED GRADE

Figure 4-2: Building Components—Sloped-Roofed Buildings

- Clipboard, ruler, colored pencil or pen;
- Aerosol can of bright marking paint;
- Sharp knife;
- Measuring tape;
- Flashlight;
- Small trowel to scrape sealant and gravel;
- Large trash bag to collect roof-top debris;
- Level;
- Camera and film—optional;
- Pocket whisk broom—optional.

## **SECTION C SYSTEMATIC INSPECTION OF THE STRUCTURE, ROOFING, AND WATERPROOFING SYSTEMS**

The following are the recommended procedures for inspecting roof and waterproofing systems, whether the systems are inspected at the same time or separately. Each inspection should follow a prescribed routine which enables the inspector to examine each visible component. Inspection guides are included in Appendix B. These guides can be used as is, or tailored to meet specific HA requirements. A typical inspection will consist of four phases:

- Visual inspection of building interior;
- Visual inspection of building exterior;
- Visual inspection of roof or waterproofing system and components;
- Analysis and recommendations.

The basic components of each phase are illustrated in Figures 4-3 and 4-4.

Under certain circumstances, a fifth phase, consisting of specialized testing, may be required to determine the causes of leaks and the extent of the damage observed during the routine inspection.

## **SECTION D THE FIRST PHASE: INTERIOR INSPECTION**

Visually inspect the interior of the structure related to the roof or waterproofing systems. The following elements should be inspected:

- Check structural system for deterioration, reflective cracking, efflorescence (white powder) on walls, ceilings, underside of roof deck, and at foundation walls.
- Check for water stains on ceilings, piping, ducts, walls, and supporting members.
  - Note the exact locations of water damage by measurement to building components that can be located on roof or exterior of building. At least two measurements should be taken from convenient points such as eaves, edges, valleys, or other identifiable locations.

- Inspect interior area above damage for potential source of leak. Where water can be seen dripping through the sheathing, locating the source is relatively simple, provided there is no insulation under the roof membrane. On steeply sloped roofs where water or moisture appears on the ceiling, the rafters immediately above the moist spot should be inspected for some distance. The drip line will probably show on the rafter, and the point of water entry can be located with measurements. Some typical sources for interior leaks are:
  - Water leaking through deck penetrations;
  - Water tracking along pipes or structural members and dripping off at changes in direction or elevation;
  - Saturated insulation on water and drain-line piping;
  - Condensation below HVAC ducts. (Note that stains below HVAC ducts may result from condensation or from pipe defects.)
- When the source is not readily apparent, inspect penetrations such as vent pipes, where such leaks may develop. Note these locations with measurements, and record. Discussions with tenants may be helpful in determining whether or not the leak occurs every time it rains, only during hard-driving rains, or some time after a rain has ended.

## **SECTION E THE SECOND PHASE: EXTERIOR INSPECTION**

Transfer measurements of potential leak sources from interior inspection to exterior of building and mark locations with a lumber crayon. Visually inspect the exterior of the building. Elements that may be inspected include, but are not limited to:

- Facade—check for cracks, water stains, open sealant joints, pointing defects, loose or deteriorated brick, clogged weep holes.
- Parapet—check for cracks, water stains, pointing defects, open sealant joints. Such defects may be caused by base-flashing defects. Mark defect locations on the plan so the roof area near the defect can be inspected.
- Windows and door openings—check for defective sealant around window and doors, deteriorated wood and metal trim, rusted lintels, clogged window weeps and door-head flashing.
- Foundation—grading at foundation should slope away from building with no depressions in the grade against the building.
- Drainage—check for adequate support and for damage to gutters and downspouts. Leaks observed during the interior inspection can result from clogged gutters and downspouts. Also, melting snow and ice on roofs above ice dams at eaves or gutters can cause water penetration.
- Note exterior defects in relation to leaks observed during interior inspection to determine if exterior conditions are resulting in the interior damage.

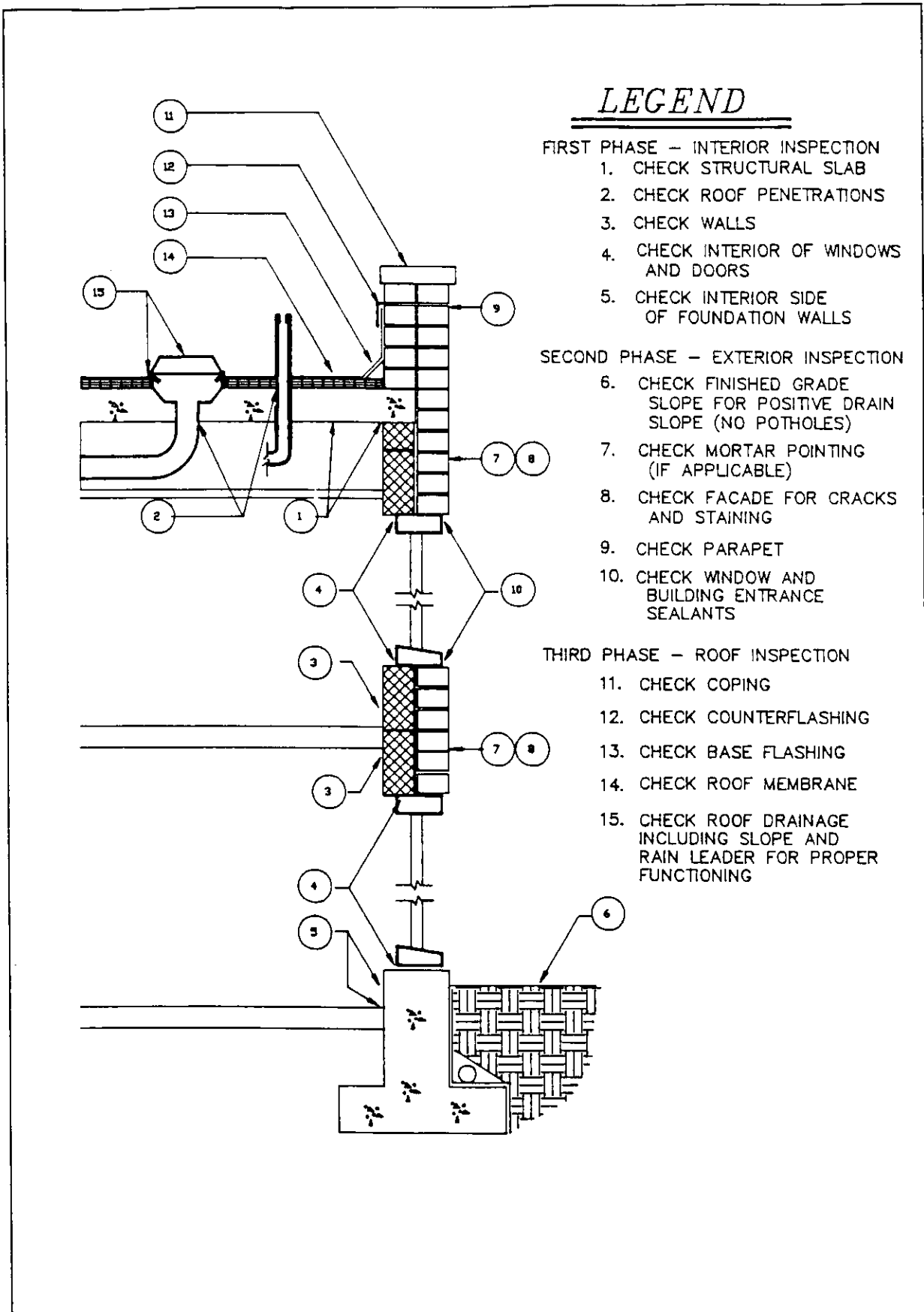

Figure 4-3: Components of a Visual Inspection

## LEGEND

### FIRST PHASE - INTERIOR INSPECTION

1. CHECK UNDERSIDE OF ROOF
2. CHECK ROOF PENETRATIONS
3. CHECK WALLS
4. CHECK INTERIOR OF WINDOWS AND DOORS
5. CHECK INTERIOR SIDE OF FOUNDATION WALLS

### SECOND PHASE - EXTERIOR INSPECTION

6. CHECK FINISHED GRADE SLOPE FOR POSITIVE DRAIN SLOPE (NO POTHOLES)
7. CHECK MORTAR POINTING (IF APPLICABLE)
8. CHECK FACADE FOR CRACKS AND STAINING
9. CHECK GUTTER AND DOWNSPOUT ATTACHMENT
10. CHECK DOWNSPOUT DISCHARGE AT GRADE (SPLASH BLOCK) OR DRAIN BOOT
11. CHECK WINDOW AND BUILDING ENTRANCE SEALANTS

### THIRD PHASE - ROOF INSPECTION

12. CHECK SHINGLES
13. CHECK PENETRATION FLASHING
14. CHECK GUTTER FOR DEBRIS, ETC.

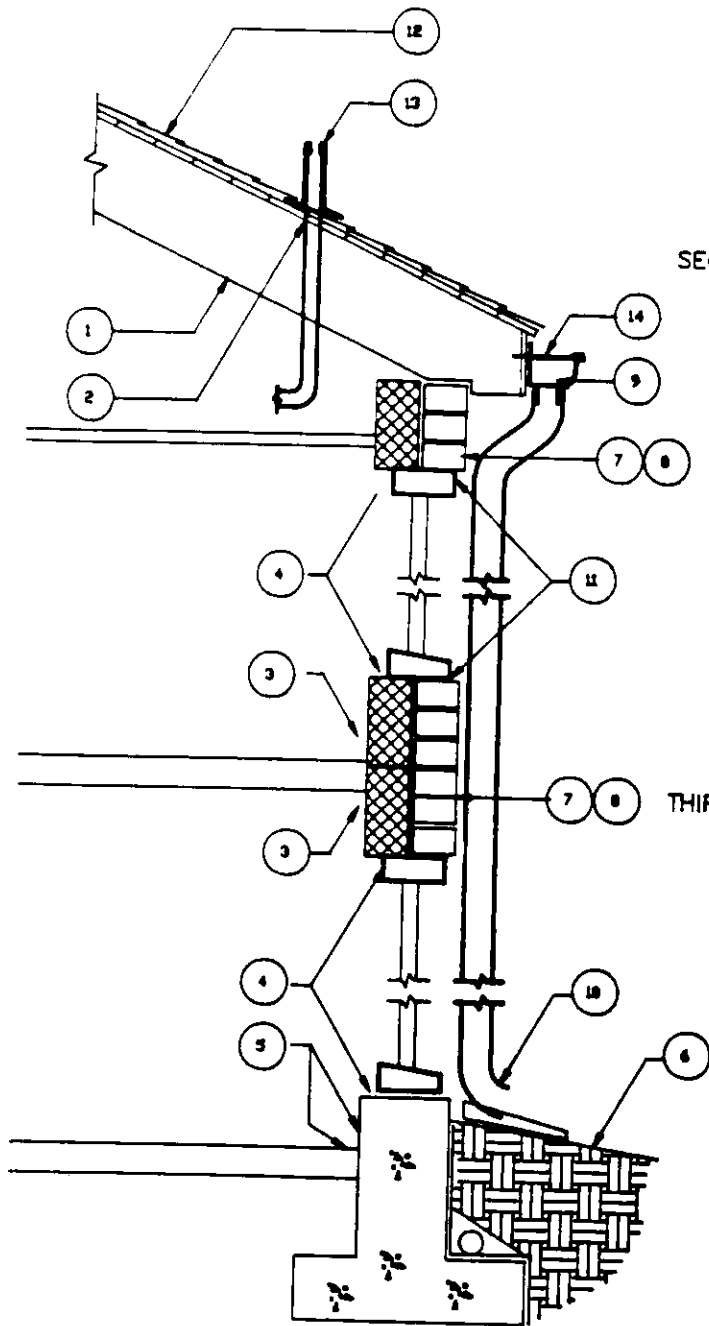

Figure 4-4: Components of a Visual Inspection-Sloped Roofs

## **SECTION F THE THIRD PHASE: ROOF INSPECTION**

This section is subdivided to provide inspection procedures for each typical roof component. Part 8 of this section is a list of typical deficiencies related to specific roof-membrane types.

It is recommended that the HA Inspectors familiarize themselves with the roof manufacturer's standard details prior to inspecting the roof. The National Roofing Contractors Association's *Roofing and Waterproofing Manual* also contains extensive illustrations of proper roof installations.

### **1. ROOF SURFACE**

Inspection of the roof surface includes all penetrations, flashings, walls, and any other items that affect the watertight integrity of the roof system. Carefully inspect areas above interior damage reported by residents or noted during the interior survey. Debris, clogged drains, ponded water, and materials left on the roof indicate the need to improve the level of maintenance.

### **2. FLASHING INSPECTION**

Many problems mistakenly attributed to roofing are actually flashing-related. When leaks occur, the flashing should be one of the first areas inspected. Typical flashing components are shown in Figure 4-5. The following are general guidelines for conducting flashing inspections:

- Check flashing height. Eight inches is the generally recommended minimum height for base flashing since water ponding on the roof during heavy rains can overtop low flashing.
- Carefully inspect the roofing materials near the flashings for signs of breaks or moisture.
- Look for punctures, broken laps or seams, separation of flashing from vertical surfaces, and signs of weather deterioration. Flashings exposed to direct sun deteriorate more rapidly than those not facing the sun.
- Check to see that roofing felts and base flashing sheets are tightly adhered to the cant strip or adjacent wall surface. Loose base flashing can be detected by gently tapping the flashing by hand mid-way between the roof and the vertical surface.
- Check for discoloration and other evidence of water entry on the inside and outside of walls and parapets. Areas in question should be clearly marked for repair.
- Check for wrinkling in the base flashing. This is a sign of differential movement between the roof and the wall or that the base flashing is inadequately nailed.
- Check metal counterflashing for deterioration and see that it is properly wedged into place or is securely fastened to a receiver, whichever is applicable.
- Check that the sealant at the top edge of surface-mounted counterflashing is well bonded to the wall and the counterflashing. Sealant should be concave and shaped to drain water away from



the wall.

- Check that counterflashing is securely set in a reglet. Loose counterflashing should be reset and missing or too-shallowly set counterflashing should be replaced with new counterflashing.
- Check condition of wall above counterflashing to determine whether there are open joints, or cracks that could allow water infiltration into wall and behind base flashing. Open mortar joints should be resealed. Weep holes, which allow water to exit the wall, should not be sealed. If necessary, repoint the joints with mortar.

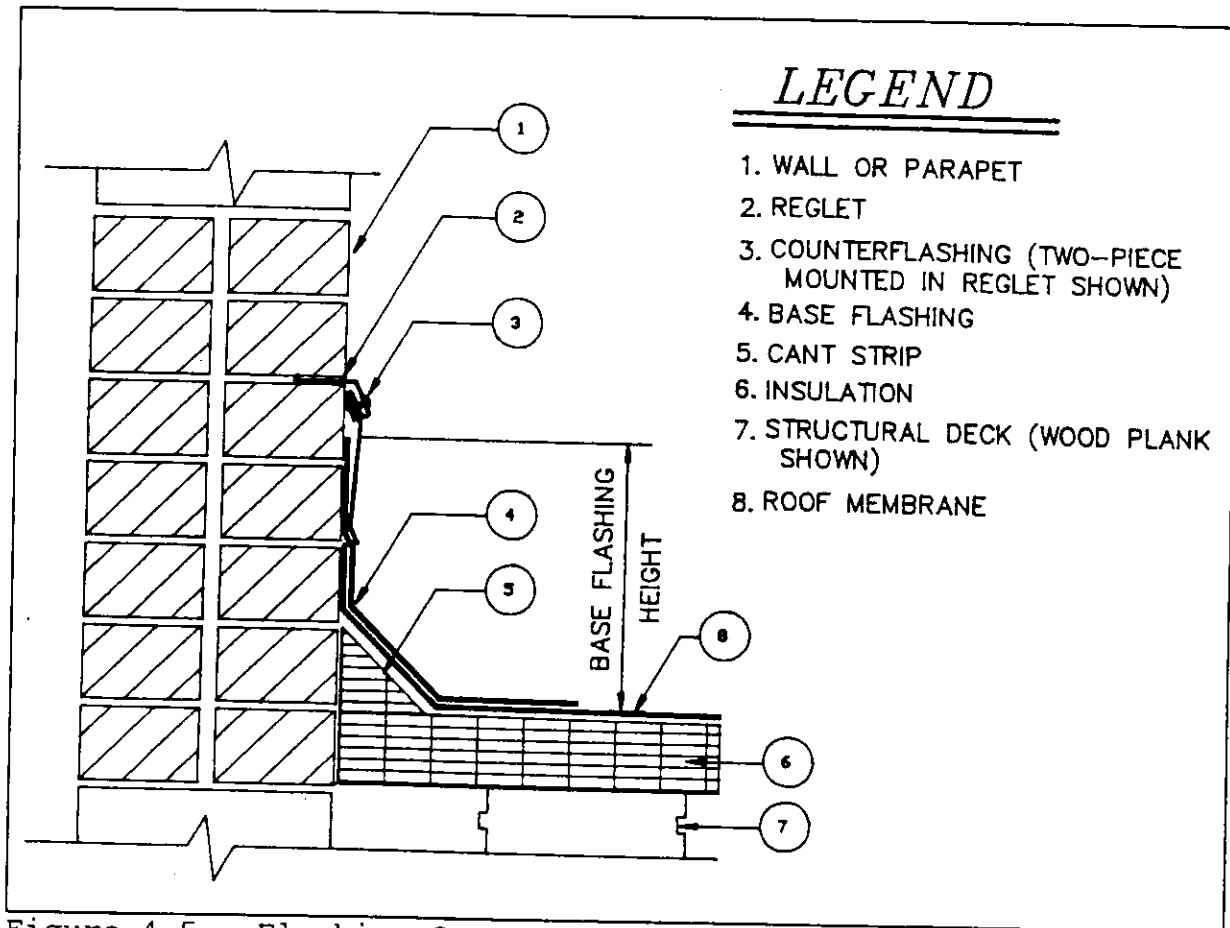

Figure 4-5: Flashing Components

### 3. DRAINAGE INSPECTION

General components of roof drainage systems are shown in Figures 4-6 and 4-7. The following is a suggested drainage inspection checklist:

- Check that the flat roof-deck slope is unobstructed and permits free drainage. Look for sagging and depressed areas, standing water, washed-out slag, or water-stained areas. Plant growth, foreign objects, and debris should be removed.
- Check rain leaders and strainers to see that they are in place and in good condition. Look for broken and clogged drains, strainers, and damaged gravel stops.

- Check for ponding water. Standing water may indicate that the drain is set too high or not in the correct location.
- Look for defective drain flashing. Determine if the roof membrane is securely clamped within the drain ring.
- Check that the roof membrane does not block or reduce the effective size of the drain pipe opening. Membrane inside clamping ring should be cut to within one inch of the clamping ring.
- Check gutter attachment to the edge of roof to determine whether it is adequately supported. Note whether gutter is clear of debris, gutter joints are sealed watertight, and if there are holes in the gutter. Verify that the gutters are level or slope downward to the downspout and that the downspout is firmly secured to the outlet tube.
- Check that the downspout is free-draining at grade, adequately connected to a ground drain pipe or that the splash blocks are properly located, and water is discharged to an area with good slope away from the building.

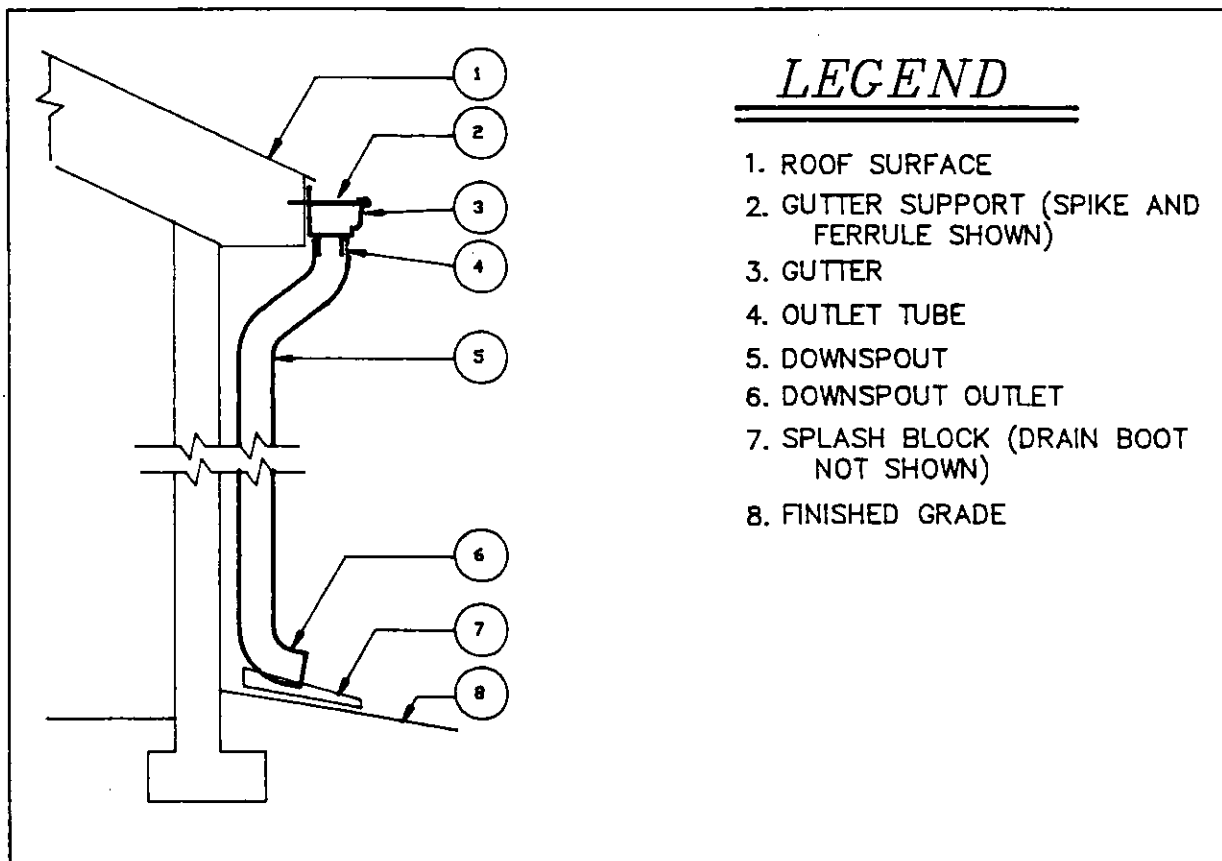

Figure 4-6: Gutter and Downspout Components

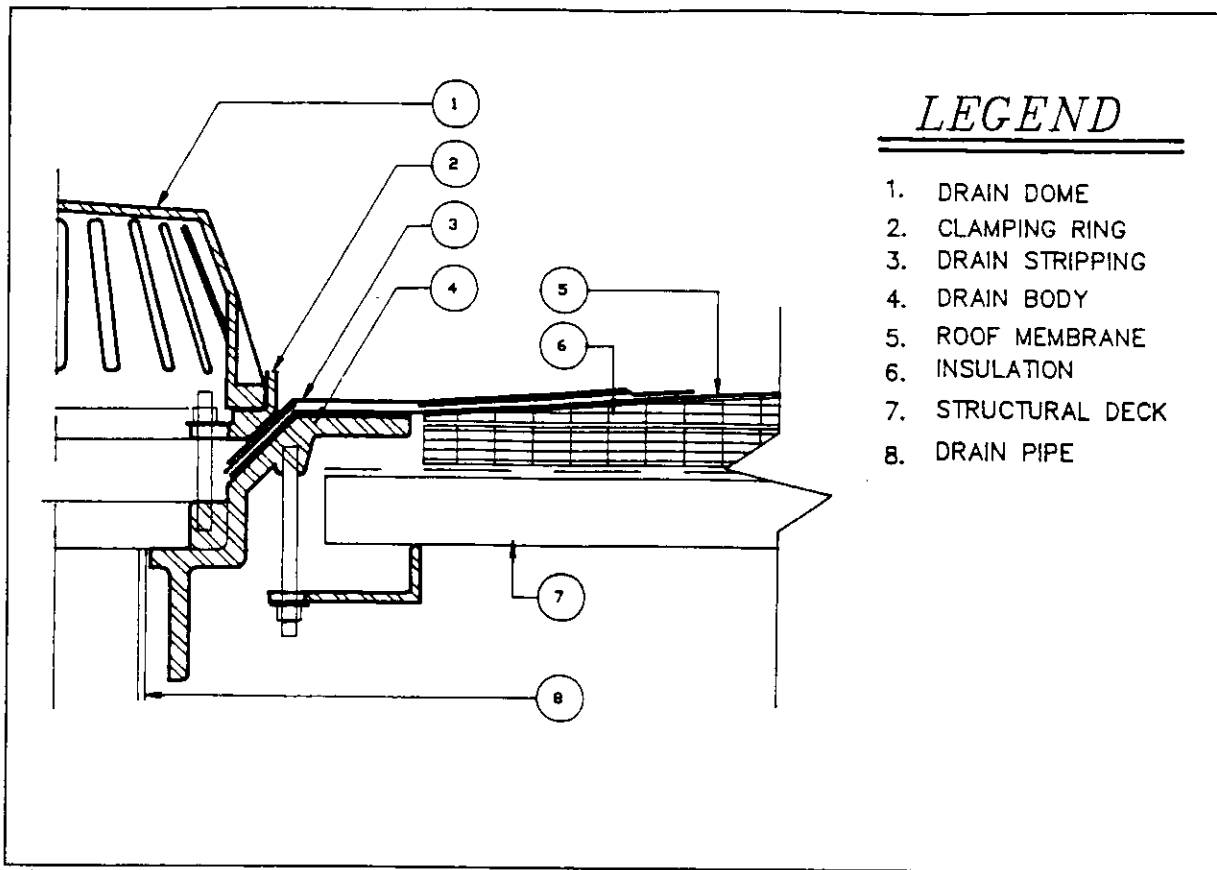

Figure 4-7: Roof Drain Components

#### 4. ROOF EDGE INSPECTION

Gravel stops and metal roof-edge strips embedded in the roof membrane often leak because the metal and roofing materials expand at different rates and thus separate. The separations appear as splits between the roof membrane and the metal. This type of gravel-stop installation is shown in Figure 4-8. Roof-edge details should be inspected for:

- Damaged, missing, unattached, or deteriorated overhanging material and fascia boards;
- Split or cracked stripping felts;
- Open or broken joints between metal pieces.

#### 5. COPING INSPECTION

- Determine whether the coping on the parapet wall is masonry, membrane, or metal. If metal, note the type and thickness/gauge/weight and update in the Historical Data File if necessary.
- Check for open mortar and sealant joints which require repair.
- Check that the roof membrane continues over the top of the parapet below the coping. If not, determine if the counterflashing is adequate.
- If the coping is metal, note the condition of the finish. Check for peeling paint, rust, corrosion, and

holes.

- Check whether exposed fastener heads are sealed watertight.

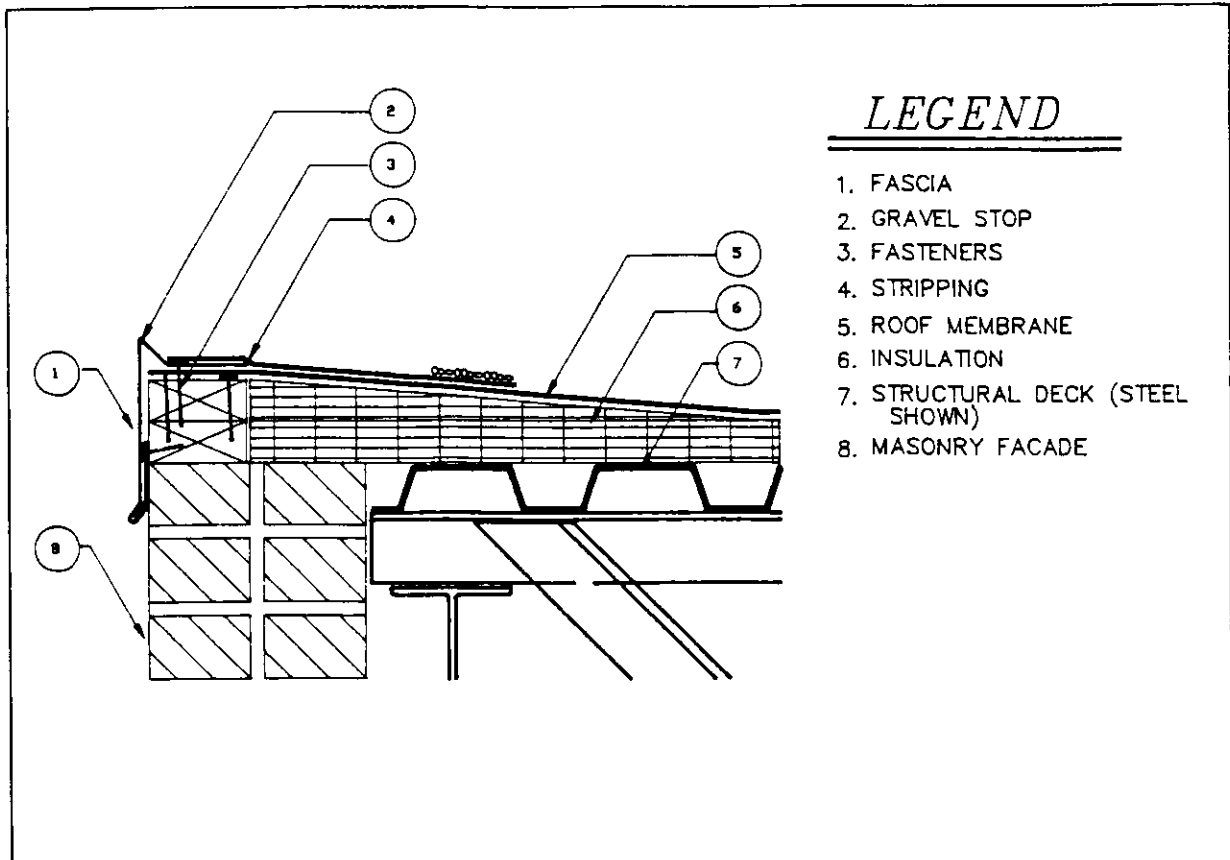

Figure 4-8: Gravel Stop Components

## 6. MEMBRANE INSPECTION

- Determine the roofing membrane material—bituminous, elastomeric, asphaltic shingle. Verify and update the Historical Data File if necessary.
- Check the Historical Data File to see if the roof is a re-cover.
- If there are patches, note their condition, especially the tie-ins with the existing roof membrane.
- List observations including, but not limited to, debris and clogged drains.
- Examine surface of roof for compliance with original specifications. The aggregate on built-up roof should fully cover the felts and flood coat. There should not be any bare spots. In ballasted systems, the ballast should be well distributed. In fully-adhered or mechanically-fastened systems, fasteners should not be backing out. Note any exposed felts, open seams, loose fasteners, or other areas of deterioration which need to be repaired.
- Check the condition of walkway pads, pavers, and the roof adjacent to them.
- Check for ponding and, if any, note its location, extent, and depth on roof plan.
- Emphasize the need for preventive maintenance if necessary, including, but not limited to, removal

of debris and foreign objects that can damage the membrane, redistribution of ballast, coating of a smooth-surfaced membrane, and re-embedding of aggregate at exposed felts on built-up roofs.

## **7. ROOF-TOP EQUIPMENT SUPPORT INSPECTION**

Equipment typically encountered on roofs includes fans, heat pumps, and large and small HVAC equipment. These items are mounted on curbs, post-and-beam frames or, sometimes directly on the roof membrane. Inspect the supports to ensure that they are flashed water-tight. The following items should be considered as part of this inspection.

- Check supports for corrosion, and note the condition of painted surfaces.
- Check base flashing and attachment of membrane to supports. Note any deteriorated, loose, or open base flashing.
- If there are rain shields on supports, check that they are securely fastened and sealed water-tight.
- Check if there is any new equipment and note whether it has been installed in accordance with roofing manufacturers' recommendations. Also, note any equipment that has been removed.
- Check if unauthorized antennae or other objects have been installed on roof and need to be removed.

## **8. INSPECTION PROCEDURES BY MEMBRANE TYPE**

The following list is intended to supplement the general inspection guidelines listed above (see the Glossary for definitions of deficiencies). Note the locations and extent of deficiencies on the inspection roof plan. Illustrations of typical built-up roof deficiencies are shown in Figure 4-9.

### **a. Built-Up Roof**

Built-up roof membranes are constructed of layers of roofing felt with bitumen between the felts to provide the waterproofing. The roof can be either smooth-surfaced (usually painted with aluminum roofing paint), or surfaced with gravel or slag embedded in a flood coat of bitumen.

Check built-up roofs for the following deficiencies:

- Blisters: note the size and whether they are broken or unbroken. Mark unbroken blisters with highly visible paint so that others on the roof can avoid walking on blisters.
- Slippage and ridges;
- Splits, holes, fishmouths;
- Loss of top surface or coating, exposed and deteriorated felts, alligatoring (see Figure 4-9), lack of adhesion between plies.

BUILT-UP ROOF DEFICIENCIES

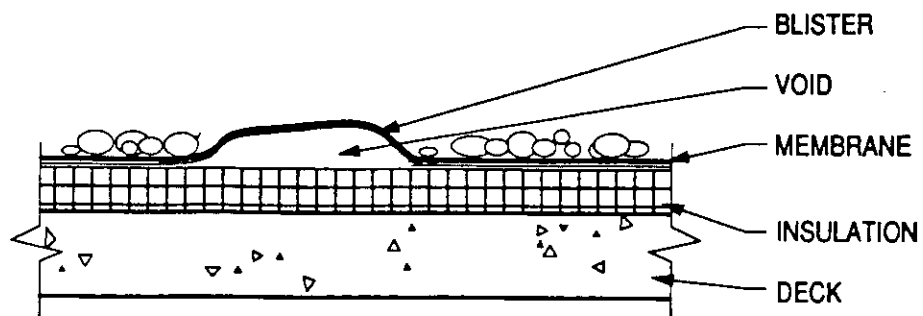

GRAPHIC REPRESENTATION OF A MEMBRANE BLISTER

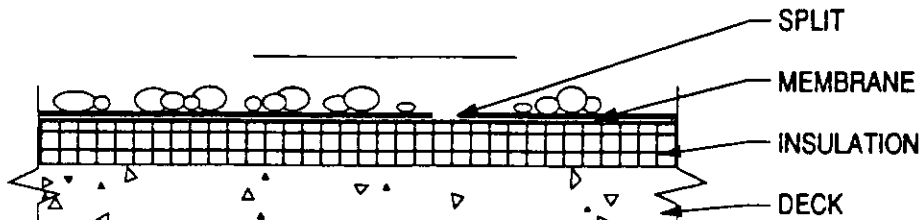

GRAPHIC REPRESENTATION OF A MEMBRANE SPLIT

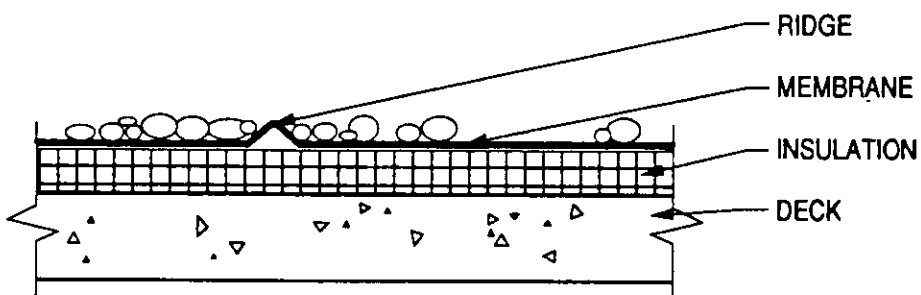

GRAPHIC REPRESENTATION OF RIDGES IN A MEMBRANE

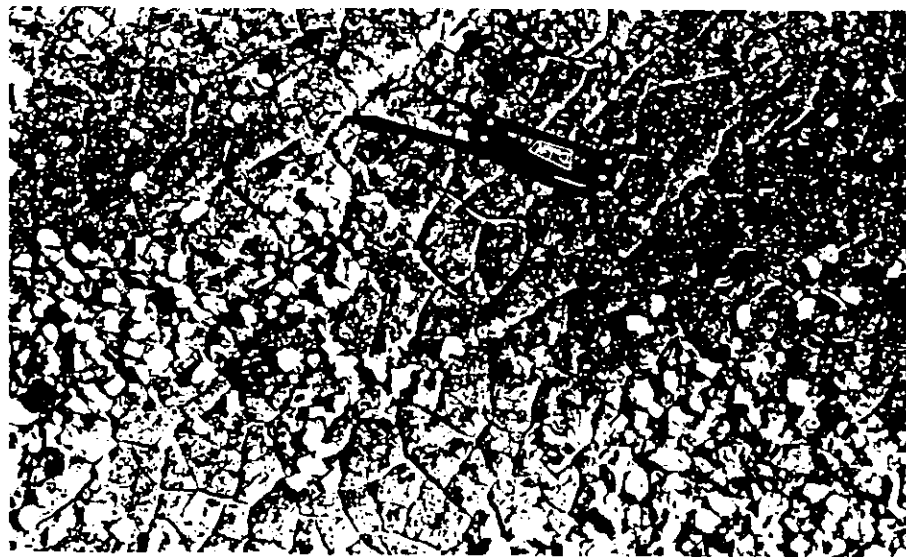

Alligatored flood coat

Figure 4-9: Built-Up Roof Deficiencies

## **b. Modified Bitumen Roofing**

Modified-bitumen roofing is either mineral or smooth-surfaced roofing material, typically applied in three-foot strips with bitumen visible at the seams. The material appears similar to roll roofing, except that the membrane is much thicker. Check modified-bitumen roofing for the following deficiencies:

- Open seams, membrane, and base flashing;
- Worn mineral or other type of surfacing.

## **c. Roll Roofing**

Roll roofing is roofing felts that have been treated with asphalt and surfaced on one side with small mineral aggregate. Although this material is not typically used, it may be present on some maintenance or storage buildings. Check for the following:

- Open or improperly cemented, nailed, or lapped seams;
- Poor surface conditions, including worn or lost surfacing, weathered edges, and holes.

## **d. Metal Roofing**

There are various metal roofing systems. The first step in inspecting a metal roof is to identify the type of metal used so that appropriate materials can be specified for the repairs. Then check for the following conditions:

- Deterioration of painted surfaces;
- Rust;
- Small holes, cuts, and punctures;
- Loose seams;
- Open solder joints;
- Inadequate flashing height;
- Erosion, especially on copper roofing. Check areas where there are concentrated drainage flows, valleys, crickets, or changes in roof elevation for thin or worn metal sections. (If the metal is worn, the surface can be painted to protect it from further wear. If an area is thin, a metal patch should be installed. If the thin area is large, the metal should be replaced.)

## **d. Slate, Tile, and Other Rigid Roofing**

Typical slate roof components are shown in Figure 4-10. Check for the following:

- Broken, missing, and loose tile;
- Unsealed fastener heads;

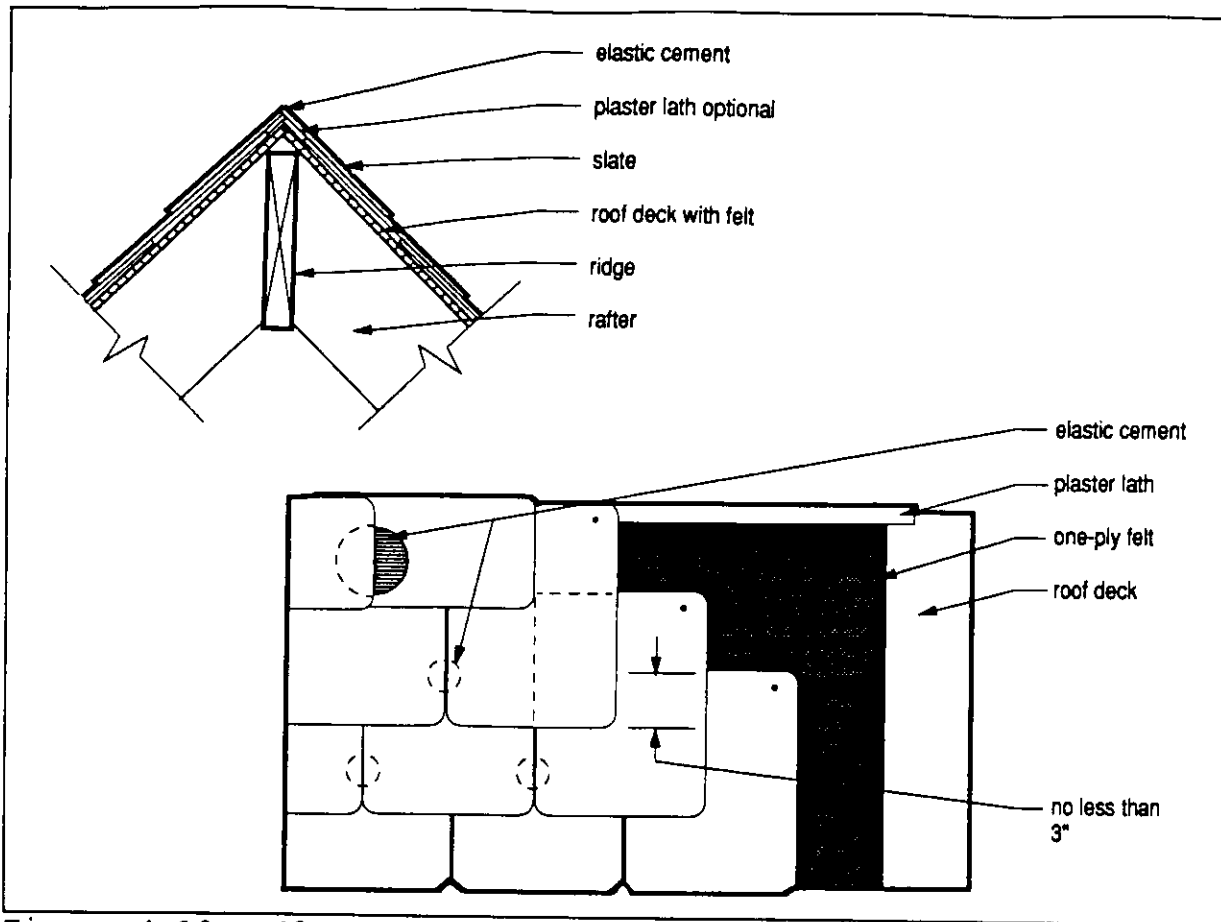

Figure 4-10: Slate Roof Components

- Inadequate head laps;
- Rotted nailers;
- Deteriorated underlayment (visible where tiles are missing);
- Deteriorated fasteners (look at loose tiles);
- Metal flashing—see criteria for metal roofs. Check erosion in drainage channels, along valleys, and at drip lines.

#### f. Asphalt Shingles

Check for the following:

- Loss of mineral surfacing;
- Splitting and surface cracking;
- Wind damage at "free" tabs;
- Improper overhang or lack of drip edge at rake and eave, resulting in rotting of wood sheathing;
- Curling or cupping, brittleness;
- Evidence of leaks at projections like vent pipes.



## **SECTION G THE FOURTH PHASE: WATERPROOFING INSPECTION**

### **1. GENERAL**

The Inspector should start with a sample inspection of exterior wall finishes, including mortar joints, sealant joints at window and door perimeters, window stiles, and building expansion joints. This inspection should provide enough information to determine whether a detailed inspection is required. When there is interior damage potentially associated with the waterproofing system, the wall areas above and near the interior damage should be carefully inspected. For leaks at and below-grade, the ground surface drainage at the wall exterior, the foundation waterproofing, and the footing drain, if any, should be inspected.

### **2. WATERPROOFING INSPECTION**

#### **a. Foundation**

Check foundation walls for efflorescence, flouing of plaster, water stains, cracks, and spalls. If there are water stains on the walls, note their extent and location on a sketch elevation of the wall. Check the basement floor for ponded water or watermarks, and check floor drains to be sure they are clear. If there is a sump pump, lift the float to engage the pump to be sure it operates.

Most foundation leaks can be corrected by eliminating depressions (pot holes), by sloping the finished grade away from the foundation, and by connecting the downspouts to closed conduits. During the exterior inspection, note the following items related to the foundation waterproofing:

- Depressions and slope of finished grade;
- Location of roof drainage discharge and how (whether) it is directed away from the building.

#### **b. Brick Masonry Facades**

Inspect the facade for the following deficiencies:

- Open mortar joints;
- Clogged weep holes;
- Open or deteriorated sealant at soft joints;
- Exposed reinforcing;
- Efflorescence (white powdery substance on the face of a wall);
- Stains or discolorations;
- Cracked brick units. Note whether they are isolated breaks or part of a larger crack extending through several courses of the masonry. (Cracks resulting from differential

settlement or from shrinking and swelling soils require an engineering study.)

- Spalled bricks. Note whether they are single bricks or part of a larger area of deterioration.

If any of these conditions are observed, make a sketch of the facade and mark the locations and extent of the deficiency.

## **SECTION H THE FIFTH PHASE: ANALYSIS AND RECOMMENDATIONS**

After all the data is collected, recommendations for any maintenance, repair, or replacement should be made. Maintenance and repair that are within the capabilities of the HA should be accomplished shortly after the inspection, preferably when the weather is good. Otherwise, the use of contract labor should be considered. When there is structural damage, a structural engineer should be contacted for assistance.

## **SECTION I THE SIXTH PHASE: ADDITIONAL TESTING**

At times additional testing is required to confirm the suspected leak sources and to assess the extent of damage, such as wet insulation. Pinpointing the source or cause of leaks can often be accomplished by in-house HA staff by water-testing. Procedures for locating leaks are outlined in the following sections. Identifying the extent of wet insulation, however, requires the use of specialized nondestructive testing equipment which is not typically owned by HAs. The basic technologies are discussed in Chapter Three.

## **SECTION J LOCATING LEAKS**

Leaks should be located and corrective action taken as soon as possible. Early action will limit the extent of damage to the roof and the building interiors. Leaks should be noted on the inspection plan. The procedures for locating leaks are included in the various guidelines for interior, exterior, and roof-surface inspections. If leak sources are not readily apparent from visual inspection, try to locate the leak source by water-testing as described in the next section.

## **SECTION K WATER-TESTING**

### **1. WATER-TESTING FOUNDATIONS**

Dig a small pit against the foundation wall above the area of suspected waterproofing failure. Pit dimensions should be approximately two feet square by one foot deep. Visually inspect the exposed damp-proofing or waterproofing and record observations. Fill the pit with water, and keep the hose on just enough to maintain the water level. Allow the water to pond for at least one hour and

continually monitor the interior of the structure for leak. A Delmhorst Moisture Meter or similar meter can often be helpful in tests when the interior damage may be the result of increased moisture content of the wall rather than actual leaking of water. If the test is unsuccessful, water test the wall, and then any doors or windows above the leaking foundation. Lack of a proper waterproofing termination or through-wall flashing could be the source of leaks. Another possible source is rising damp. This phenomenon, which results from ground water rising in masonry foundation walls by capillary action, would not be apparent from water testing. (Delmhorst Moisture Meters are manufactured by Delmhorst Instrument Company, 50 Indian Lane East Towaco, New Jersey 07082, Telephone 800/222-0638.)

## **2. WATER-TESTING WATERPROOFED WALLS**

Start water-testing by spraying water at the lowest point of the wall that could possibly contribute to the leak; do not test the wall below the interior leak. For an extended test, a sprinkler can be useful. After allowing sufficient time for water to penetrate the wall, spray the wall at a higher elevation. When water penetrates the structure, note the location being tested and stop the test. Clean-up and remove water from the interior area. For leaks associated with wind-driven rain, water-testing may not be effective. Therefore, results obtained from water-testing walls may not always be conclusive.

## **3. WATER-TESTING ROOFS**

Isolate the roof area above the leak, plug the roof drain with a removable plug, and flood the isolated roof area. Have an assistant continually monitor the building interior at the leak location for the entry of water or moisture. The assistant should notify the tester when the leak starts. If no leak occurs after approximately one hour of flood testing, remove the drain plug. Then move the hose and spray the flashings near the leak, one at a time. The approach should be to water-test from the lowest point to the highest point of the roof. When the interior leak starts, note the area being tested, shutoff the water, and clear the roof of water. Provide buckets and rags at the interior leak location to collect the water penetrating from the water-test.

## **4. LENGTH OF TESTS**

One hour is typically sufficient time for water-tests to produce results. If a leak occurs in less time, the test should be stopped immediately and the water leak cleaned up. The main factors contributing to the length of time are the severity of the leak and the mass and porosity of material which the water must penetrate to appear on the interior.

## **5. VERIFY RESULTS**

Moving water quickly from one location to another during testing can lead to inaccurate results. If there is doubt about the result of a test, allow water to stop leaking and repeat it. Since the leak path is already established, retesting should produce results much more quickly than the original test. It is important to note that successful water-testing is a systematic and methodical means that requires practice and patience.

## **6. EXERCISE CAUTION**

Prior to water-testing roof systems, the live-load capacity of the roof should be checked to ensure that the water to be ponded on the roof will not overload the structure. (Water weighs approximately 5 pounds per square foot per inch of depth). A water test may result in additional damage in the interior of the building. Therefore, the inspector should evaluate the potential for interior damage to the structure, private property, and equipment when determining to water-test, and should take precautions to protect the interior elements (for instance, move furniture and cover items with plastic).

Water-testing may not be successful on re-cover roofs because water can travel between the original and re-cover roof for great distances before leaking into the building at a deck crack or penetration. Water can collect on the original roof membrane and not leak into the building until well after the Inspector has left the property.

## **7. EQUIPMENT**

The following equipment is required or useful for water-testing:

- Hose;
- Spray nozzle, sprinkler, or soaker hose as required;
- Bucket, rags, and shop vacuum (if available) to catch water;
- Drain plugs;
- Plastic sheeting and duct tape to isolate water-test areas;
- Flashlight;
- Hose bib key, if needed;
- Delmhorst or other comparable moisture meter (if available);
- Tape measure to identify location of leak. Measure leak location from anything that can be seen at the exterior of the building, such as a vent pipe or a fan housing.

**END OF CHAPTER FOUR**

# **MAINTENANCE GUIDEBOOK V**

## **ROOF AND WATERPROOFING MAINTENANCE**

### **CHAPTER FIVE - MAINTENANCE AND REPAIR**

#### **SECTION A INTRODUCTION**

This chapter discusses the basic requirements for maintaining roof and waterproofing systems and methods for repairing deficiencies. The repairs, except as noted, should be within the capabilities of most local HA maintenance staff.

#### **SECTION B MAINTENANCE**

##### **1. DRAINAGE**

All foreign matter including slag, vegetation, and debris, should be removed from drains, gutters, downspouts, scuppers, conductor heads, and at-grade downspouts to storm drain connections under a preventive-maintenance program.

###### **a. Ponding**

Roof areas where water ponds in excess of one inch in depth after 48 hours should be corrected by the addition of roof drains or tapered insulation, or by lowering the existing roof drains. Such repairs, however, may be beyond the capabilities of in-house HA maintenance staff and may need to be contracted. Prior to contracting for repairs, a Scope of Work should be developed by a knowledgeable HA staff member or an Architect or Engineer, depending on the complexity of the work to be performed.

##### **2. SMALL REPAIRS**

Small repairs to roof components are considered a part of the preventive and regular maintenance program. (Roof repair methods are described in Sections D-I by membrane type.) In performing any repairs, the HA staff should be aware of warranty requirements. Most warranties require that the manufacturer be notified in advance and that the repairs be made by an approved contractor.

### **3. FOOT TRAFFIC**

Foot traffic on roofs should be kept to a minimum. If equipment on the roof requires frequent maintenance, install walk pads, following roof-membrane manufacturers' recommendations for installation, to protect the roof from damage. Residents frequently seek access to the roof for a number of activities, ranging from sunbathing through antenna installation, and most do not understand the damage that foot traffic and puncturing of the membrane can cause. HA staff may need to educate residents about the effects of their actions in order to gain their cooperation in limiting roof-top foot traffic. Although the HA's policy on keeping roof doors and hatchways locked will require balancing fire fighters' needs for access through the roof against property damage due to residents' access to the roof, HAs should consider controlling access to the roof by keeping doors and hatchways locked.

## **SECTION C EMERGENCY REPAIRS**

Depending on the extent of the defect, emergency repairs should be as simple as possible to allow them to be performed safely by HA maintenance staff without any delay. These repairs should be considered temporary, and permanent repairs should be made later, usually by a professional roofing contractor, as soon as weather permits.

### **1. MATERIALS, TOOLS, AND EQUIPMENT FOR EMERGENCY REPAIRS**

The following materials, tools, and equipment are suggested for emergency repairs:

- Roofing fabric, cotton, or glass fiber;
- Wet/dry roofing cement (non-asbestos);
- Roll of EPDM or 6-mil polyethylene sheeting with adhesive glues or tape;
- Bentonite (an absorptive clay useful in creating dams);
- Ballast material—sandbags, concrete blocks, wood planks;
- Wood blocks;
- Screw driver, sharp knife, scissors, and straight-claw hammer;
- Trowel for roofing cement;
- Cleaning products (409 or similar cleaner for cleaning sheet membranes);
- Brush for adhesive;
- Dry, clean rags;
- Capped nails for fastening flashing;
- Push broom;
- Water pump and hose.

## **2. TWO PERSONS FOR EMERGENCY REPAIRS**

Emergency repairs should be performed by a minimum of two persons to ensure safety. Electricity and water are a hazardous combination; always exercise caution when performing emergency repairs in the presence of "hot" wires or equipment under electrical current, such as air conditioners or heat-pump condensers.

## **3. BEFORE GETTING ONTO THE ROOF**

It is wise to accomplish several tasks even before getting up onto the roof:

- Identify approximate location of leak;
- Remove residents from apartments where potentially harmful conditions exist;
- Shut off electrical service when there is a chance that downed electrical wires may be encountered.

## **4. INSPECTION PROCEDURE DURING EMERGENCY REPAIRS**

The following inspection procedure is recommended during emergency repairs:

- Inspect roof from the access point for downed tree limbs and electrical lines. As noted above, water and electricity are a potentially deadly combination.
- Check for potential structural overloading resulting from water, snow, and ice.
- Check all roof drains, scuppers, gutters, and downspouts. Clear strainers to allow free draining. DO NOT remove strainers and reach into a drain pipe, since the sudden cleaning may cause dangerous suction. Remove additional water with brooms, squeegees, or pumps.

## **5. CAUSES OF LEAKS REQUIRING EMERGENCY REPAIRS**

### **a. Water Overtopping Base Flashings, Pitch Pockets**

Check leaks after water is drawn down by clearing drainage system. If leak has stopped, return to roof in good weather, perform inspection (see Special Inspection), and make required repairs.

### **b. Punctures at Fallen Limbs, Toppled Equipment**

- Examine roof for punctures, remove penetrating object, and patch membrane as well as possible;
- Return in good weather and install permanent, durable repair.

### c. Wind Damage

- Examine roof for membrane blow-off;
- Install battens, sand bags, concrete blocks, or take other measures to prevent more extensive wind damage to the roof membranes. CAUTION: Exercise care when placing ballast or heavy objects on roofs to hold down tarps and other materials, since additional weight may overload an already damaged roof structure. On wood and steel decks, batten strips can be fastened directly through the membrane. Tarps or other covers may have to be applied and ballasted to seal areas where the membrane has been lost.
- Wind effects usually are most severe at corners and perimeters. Look there for missing fascia metal, displaced coping, or other perimeter damage.
- Refasten loose coping, gravel stops, and other perimeter flashing. If necessary, install tarps, battens, or sand bags to prevent further damage to the roof and to stem leaks to the interior of the building.

## 6. FOLLOW-UP SPECIAL INSPECTION

Roof areas should be inspected after severe storms, and any necessary repairs should be completed without delay.

## 7. WET REPAIRS

The following is the recommended procedure for making wet repairs:

- Dry out the surface as much as possible, since "wet-patch" materials have a better chance of success when applied to dry surfaces. If necessary, dam off the area to be repaired. Use 2x4s bedded in plastic cement or sand, sand bags, or bentonite.
- Wipe the affected surface clean with rags, and dry with compressed air, fans, or hot-air guns. Use caution when using electrical devices in wet areas to avoid electrocution.
  - Built-up and Modified Bitumen Roofs: Prepare surface and repair built-up roofs in accordance with two-ply cement and fabric-patch specification outlined below.
  - Single-Ply Roofs: Solvent-clean elastomeric membranes and follow manufacturer's instructions for installation of patch materials. For loose-laid single-ply membranes, a simple repair can consist of placing a wood block below the membrane at the puncture and covering the block and hole with an upside-down bucket. Weight the bucket with a sand bag to prevent blow-off.
  - Steeply-Sloped Roofs and Metal Roofs: Install tarps and secure with battens.



## **SECTION D REPAIR OF BUILT-UP ROOF MEMBRANES**

Built-up roofing membranes are the most common membrane type on HA properties. The repair materials and procedures listed below apply to gravel-surfaced and smooth-surfaced coal-tar and asphalt-bitumen built-up roofs.

### **1. BASIC MATERIALS**

The basic materials used in built-up roof membrane repairs are:

- Roof Cement (Asphalt): ASTM D 4586, Type I, roof cement, asphalt, wet and dry, non-asbestos.
- Roof Cement (Coal Tar): ASTM D 4022, non-asbestos, coal-tar based roof cement.
- Fabric (Cotton): ASTM D 173, asphalt-saturated cotton fabric, 3.5 ounces per square yard.
- Fabric (Glass): ASTM D 1668, Type I, asphalt-saturated woven glass fiber, 3.0 ounces per square yard.
- Asphalt (for Built-up): ASTM D 312, Type III, Steep. Do not heat above 500°F; point of application temperature is 375° to 425°F.
- Asphalt (for Modified Bitumen): ASTM D 312, Type IV, Special Steep. Do not heat to temperatures greater than 500°F; point-of-application temperature is 400°F.
- Coal Tar Bitumen: ASTM D 450, Type III. Maximum kettle temperature 425°F; point of application temperature 350-450°F.
- Modified Bitumen: 160 mils thick, fiberglass or polyester reinforcing.
- Felt (Fiberglass, Type IV or VI): ASTM D 2178, continuous-strand glass-fiber coated with weathering grade asphalt.

### **2. METHODS AND TECHNIQUES**

- Tie maintenance and repair work into sound, clean (free of all surface contaminants), and dry membrane. There should be no loose felts, gravel/slag surfacing or other debris at patch area.
- Use compatible materials on all work (for instance, coal-tar based materials for coal-tar roofs and asphalt-based materials for asphalt-based roofs).
- Place debris removed from roof, gutters, and downspouts into a trash container off the roof.
- Most patches used in repair procedures are cold-applied, two-ply cement and fabric patches. These patches do not require special equipment—kettles or torches—and can be performed by in-house HA maintenance staff. Use two-ply cement and fabric patches to repair areas less than four square feet, and if equipment for making hot repairs on larger areas is not available. Use hot patches—three-ply hot-asphalt patch or membrane patch with modified bitumen—for areas greater than four square feet if equipment and properly trained personnel are available. Generally, a hot-patch is more suitable and will last longer, especially for larger repairs (greater

than two square feet).

**a. Two-Ply Cement and Fabric Patch**

Remove surface material and most of the flood coat from membrane a minimum of 12 inches beyond the edge of the area to be patched. Prepare membrane by trimming away deteriorated felts. Use care not to damage the watertight felts below. Prime area with a thin coat of asphalt primer and allow to dry; or, work cement well into membrane. Apply a 1/16-inch thick bed of roofing cement. Place one layer of fabric in cement, lapping a minimum of 3 inches onto sound membrane. Apply second 1/16-inch bed of cement and final layer of fabric, covering the first layer and lapping 3 inches onto sound membrane. Seal the total patch and spudded area with 1/16-inch cement coating. In gravel-surfaced areas, do not lap cement onto surface material. Apply surface material to completely cover patch.

**b. Three-Ply Hot Asphalt Patch**

Prepare deteriorated membrane as described for two-ply cement-and-fabric patch above. Apply 3-ply hot asphalt and fiberglass felt patch using strips 6, 9, and 12 inches wider than the area to be patched. Apply the surface material in a flood coat of hot asphalt.

**c. Membrane Patch with Modified Bitumen**

Prepare deteriorated membrane as described above. Apply mop-on or torch-on modified bitumen patch, lapping adjacent sound membrane a minimum of 12 inches from edge of deteriorated membrane. Seal perimeter of patch with two-ply cement and fabric patch.

**3. BARE SPOTS**

Bare spots consist of areas where felts are exposed from loss of gravel surfacing, flood coat, or smooth-surface built-up roof coating. Causes of bare spots include bitumen flow in coal-tar built-up roofs, wind scour, foot traffic, chemical attack, ponding water, or other weathering effects. Repair procedures include:

- Sweep loose surface material (gravel or slag), dirt, and dust from top of exposed membrane or unbroken blister or ridge without damaging the watertight plies below. Coat surface of membrane with 1/8-inch thick layer of cement, and spread surface material over the wet-cemented surface.
- On smooth-surface membranes, repair as above, and apply coating to match adjacent areas.
- If bare spots are the result of foot traffic, install walk pads in accordance with roof membrane manufacturer's recommendations.

#### 4. ALLIGATORING/CRACKING

The appearance of a pattern similar to "mud-cracking" or alligator hide on surface of roof is known as alligatoring (see Figure 4-9). This problem is common to smooth-surface built-up roofs. Excessive shrinkage of a bitumen flood coat can expose felts to the weather and stress and tear felts, allowing water intrusion. Repair, using the following procedures:

- Remove loose surface material, dirt, and dust from the top of the membrane with a broom, and coat with a material similar to that used on the remainder of the roof (clay-based emulsion or asphalt roof coating). Control thickness of application to avoid excessive coating build-up.
- When coating is severely alligatored, remove dust and dirt by sweeping or vacuuming without damaging watertight plies below. Apply one thin coat of asphalt primer, preferably by brushing. Avoid applying an excessive amount of primer. After primer is allowed to dry, apply clay-based emulsion or asphalt roof coating.

#### 5. SURFACE SLIPPAGE

Surface slippage, or down-slope lateral movement of felt plies, generally occurs on slopes greater than 1/4 inch per foot. Causes can include the following:

- Felts were not back-nailed during application of the roof membrane;
- Wrong grade of asphalt was used for the roof slope;
- Too much asphalt was used between felts;
- Interply moppings were too thick;
- Construction was phased so that the base sheet was glaze-coated and the membrane was installed at a later date.

Repair procedures include:

- Clean roof drains and gravel stops of bitumen build-up that is inhibiting proper drainage of roof;
- Repair felts exposed by slippage with procedures similar to those described above;
- Areas of excessive slippage should be repaired by a professional roofing contractor.

#### 6. BLISTERS

Blisters are round or elongated raised areas of the membrane which are filled with air and sometimes water (see Figure 4-9). Blisters are caused by moisture vapor in built-up roofs exposed to summer heat. Repair in the following way:

- Unbroken, sound blisters up to approximately one foot in diameter are best left alone. Mark perimeter of blisters with bright orange spray paint to prevent foot traffic across blister and for easy reference during subsequent inspections to see if blisters are growing.

- Bare spots on tops of blisters should be treated as described in Section D.3 above.
- Repair broken blisters as follows:  
Remove the entire blister to its edges where the membrane is sound. Allow resulting depression to dry. Fill depression with fitted felt set in 1/8-inch-thick layers of roof cement. Apply two-ply cement and fabric patch over the filled area, extending onto the surrounding sound membrane.
- Cut away large blisters and repair per broken blister procedures.
- At large repairs, consider applying three-ply hot patch.

## 7. SPLITS

Splits are tears that extend through the membrane felts (see Figure 4-9). Splits vary in length from a few feet to the width of the roof and in width from a hair-line crack to more than an inch. Causes include the following:

- Membrane felts are too weak;
- Attachments among membrane, insulation, and decking are minimal;
- Differential movement;
- Structure undergoes expansion and contraction.

Repair procedure is the following:

- Identify cause of split in the membrane. If cause is not readily ascertained, or if the repair requires outside contract work, perform temporary repair with two-ply cement and fabric patch.
- Repair splits caused by differential movement by installing a curbed structural expansion joint.
- Repair splits caused by weak membrane or unsecured materials by reattaching the membrane, insulation, or other material to the deck with appropriate fasteners. Patch split and heads of fasteners with two-ply cement and fabric patch.

## 8. RIDGES

Ridges are long, narrow raised portions of the roof membrane (see Figure 4-9). Usually ridges occur directly above insulation-board joints and run perpendicular or parallel to the felts. They include all plies of the membrane and therefore are generally stiffer than blisters. Causes include excess moisture vapor build-up at insulation joints, slippage of membrane perpendicular to the roof slope, and a poorly attached membrane. Repair ridge in accordance with repair procedure listed for Bare Spots and Splits (see Sections D.3 and D.7). Note the repair on roof plan, and schedule periodic follow-up inspections.

## 9. HOLES

Holes are punctures through the roofing membrane. They come from a large number of sources, such as falling debris, vandalism, or damage during work on roofs. Repair by application of two-ply cement and fabric patch.

## 10. FISHMOUTHS

Fishmouths are half-cylindrical openings at the edges of felts and cap sheets. They are caused by excessive pulling of the felts during installation, application of felts with wet edges, or insufficient bitumen application. Repair by the following procedures:

- If the fishmouth is less than 2 inches deep, loose material may be cut away and discarded.
- For deeper fishmouths, cut away loose material until sound, well-bonded material is encountered, and apply two-ply cement and fabric patch.

## 11. PATCH FAILURE

Patches are previous repairs in the membrane. Failures can be caused by improper repair and aging. Repair by the following procedure:

- Perimeter Repairs: Seal open areas with two-ply cement and fabric patch.
- Surface Repairs: Repair surface defect or splits in accordance with appropriate repair procedure described previously.

## 12. BASE FLASHING DEFICIENCIES

Base flashing consists of material providing the watertight transition between the roof and the wall, parapet, equipment curbs, equipment supports, and chimneys. Base flashing is constructed of asphalt-based composition-roofing material or metal (older installations). Base flashings should be a minimum of 8 inches high, securely fastened at the top and firmly adhered to wall and cant surfaces. The top 3 to 4 inches of the base flashing should be covered with counterflashing. Base flashing deficiencies consist of openings at the top of the flashing, a top edge of flashing which is too low, inadequate cover by counterflashing, open seams, holes, and poor securement to wall. Defective base flashing should be repaired. Causes include cracks or breaks in vertical joints of the metal base flashing, incompatible thermal movement between metal base flashing and roof membrane, punctures, broken laps at seams, separation or sagging from wall, disintegration of surface coating, and differential movement between roof deck and wall. Figures 5-1 through 5-4 show some of these deficient conditions with associated repairs.

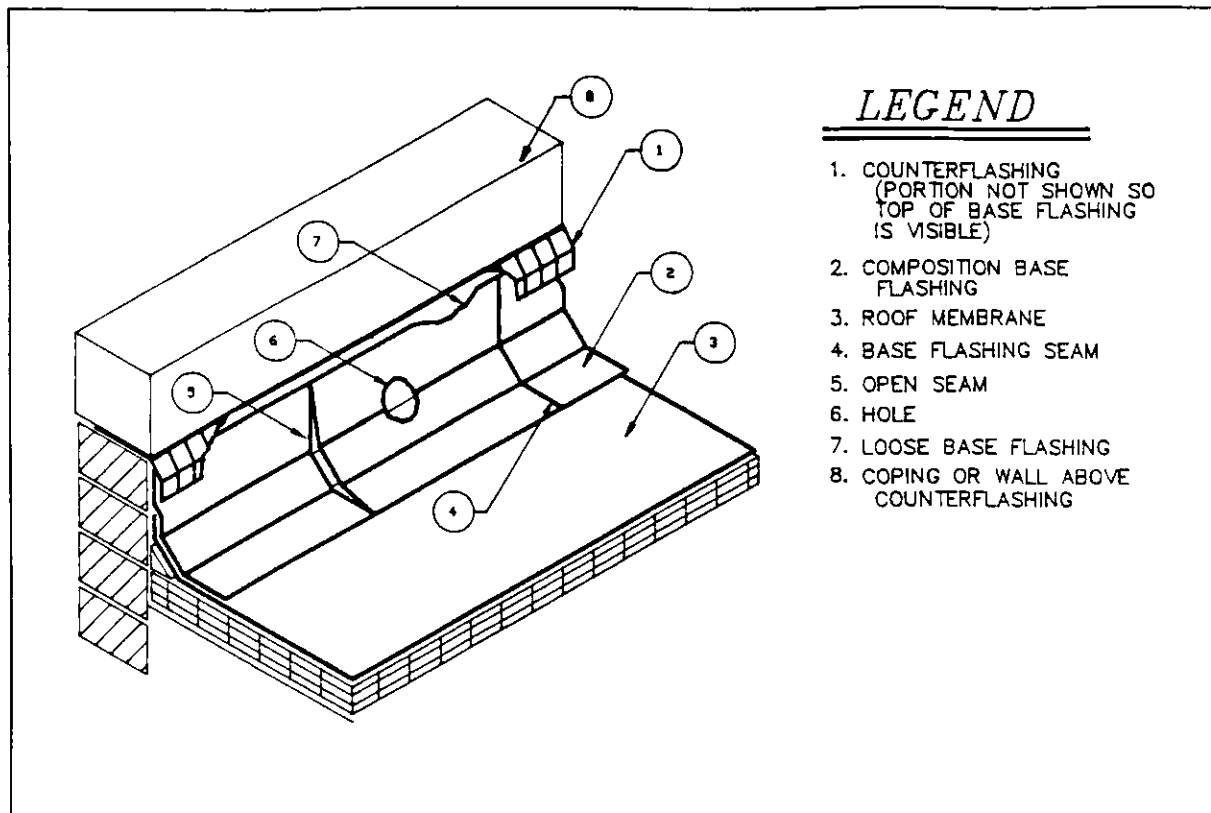

Figure 5-1: Composition Base-Flashing Open Seam

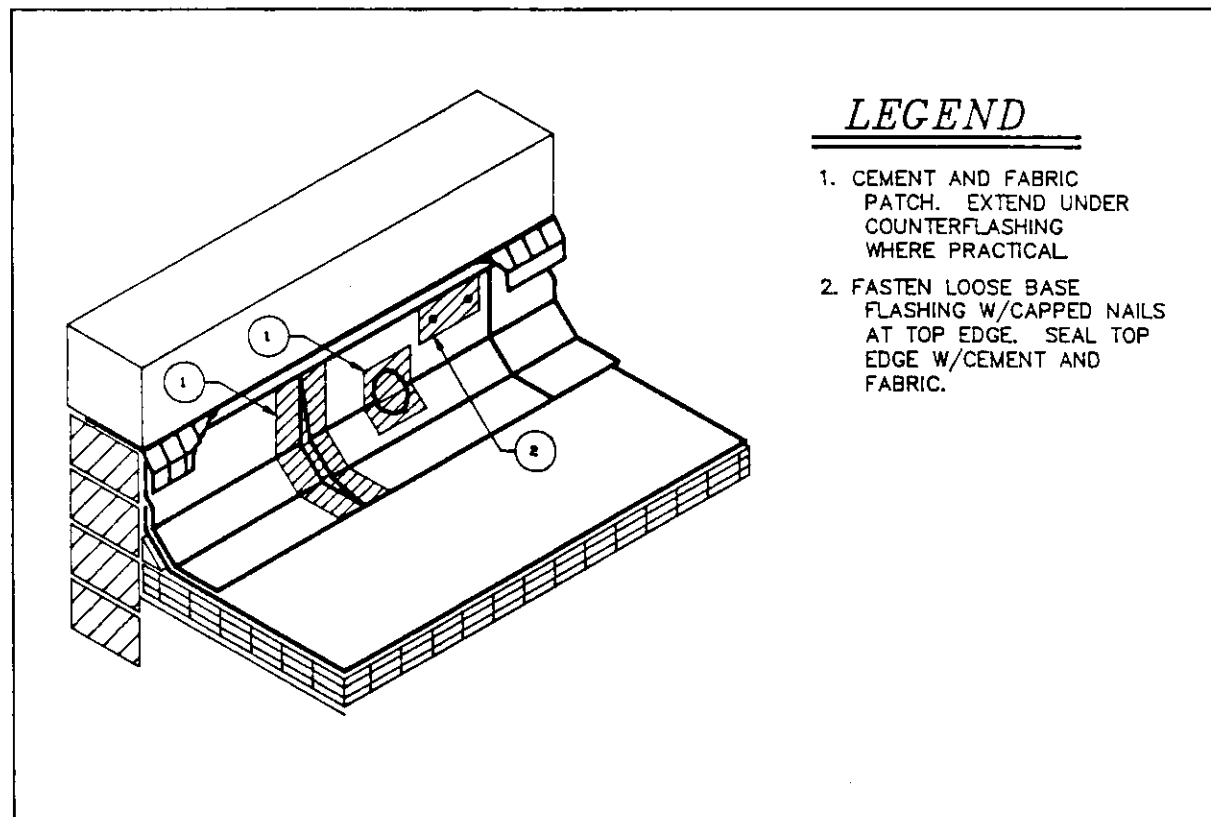
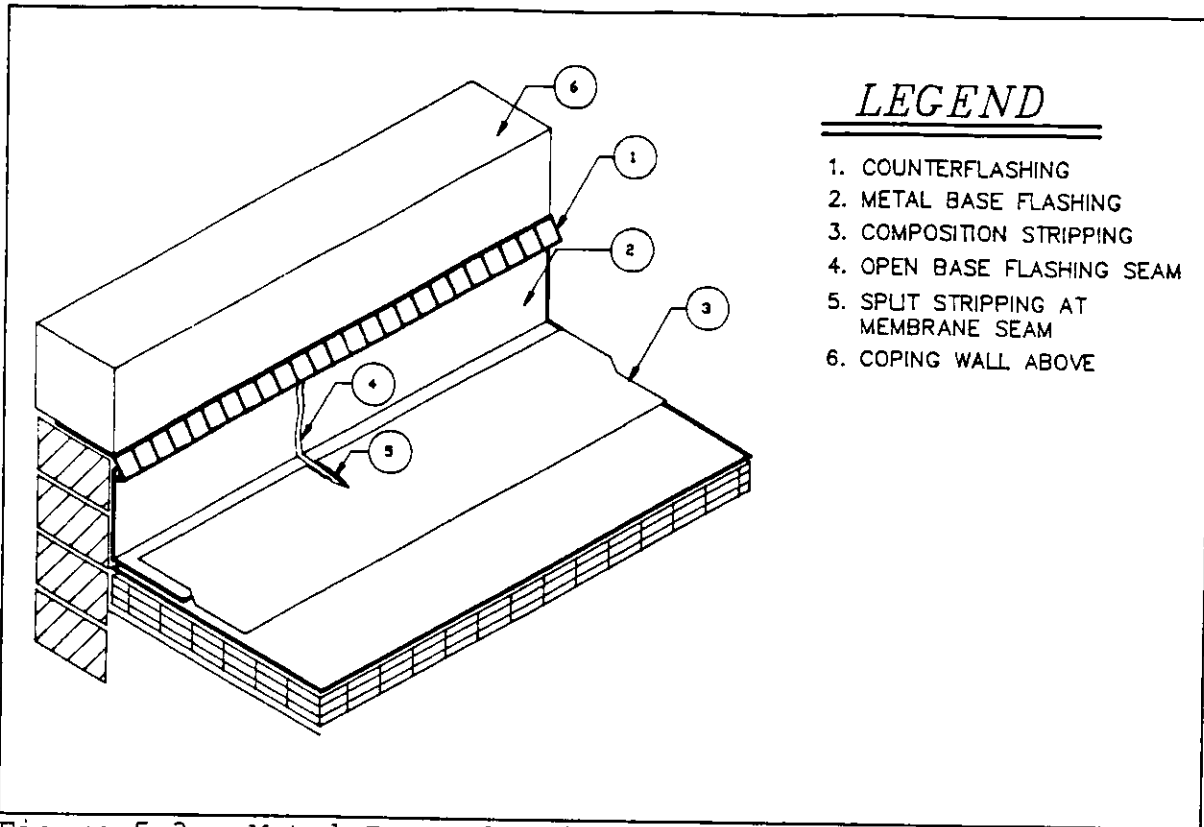

Figure 5-2: Repair of Composition Base-Flashing Open Seam



LEGEND

1. COUNTERFLASHING
2. METAL BASE FLASHING
3. COMPOSITION STRIPPING
4. OPEN BASE FLASHING SEAM
5. SPLIT STRIPPING AT MEMBRANE SEAM
6. COPING WALL ABOVE

Figure 5-3: Metal Base-Flashing Open Seam

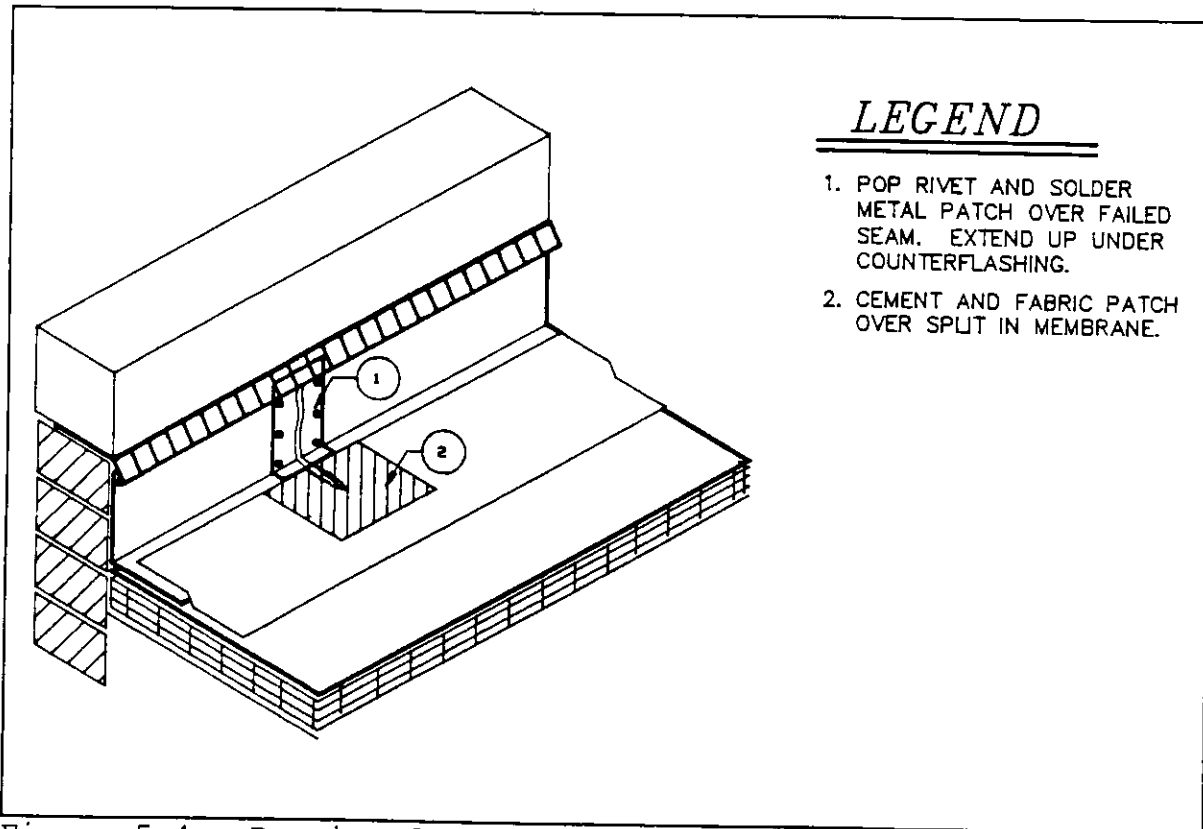

LEGEND

1. POP RIVET AND SOLDER METAL PATCH OVER FAILED SEAM. EXTEND UP UNDER COUNTERFLASHING.
2. CEMENT AND FABRIC PATCH OVER SPLIT IN MEMBRANE.

Figure 5-4: Repair of Metal Base-Flashing Open Seam

Repair procedures include the following:

- **Open Metal Base Flashing Seams** (see Figures 5-3 and 5-4): Repair cracks and breaks in vertical seams by cleaning metal and resoldering, or install soldered metal patch over joint. If defect is close to coping or cap flashing, extend repair a minimum of 1 inch under flashing.
- **Splits between Roof Membrane and Metal Base Flashing:** Remove surface material and flood coat a minimum of 9 inches from the edge of base flashing and 6 inches beyond the extent of damage. Remove deteriorated stripping. Clean and solder open joints. Install two-ply cement and fabric patch overlapping the sound membrane 6 inches.
- **Deterioration of Metal Base Flashing Coating:** Clean, prime, and paint metal with rust inhibitive primer and two coats of good, exterior grade alkyd paint.
- **Punctures:** Install two-ply cement and fabric patch on composition base flashings. Temporarily repair punctures in metal base flashings with two-ply cement and fabric patch. Permanent soldered repairs may be beyond the capabilities of HA maintenance, and may require outside contract work.
- **Broken Laps and Split Seams in Composition Base Flashing** (see Figures 5-1 and 5-2): Seal all cracks, holes, and open seams in composition base flashing with two-ply cement and fabric patch. Terminate cement and fabric repair 1 inch under counterflashing or coping, if within 6 inches.
- **Separation/Sagging at Wall:** Small areas of sagging and separation can be left alone as long as they are properly counterflashed. At larger areas, embed loose base flashing in full coating of roofing cement applied to wall, and secure base flashing plies to wall with capped nails or nailins spaced 12 inches on center. Seal fastener heads and top of base flashing with cement and fabric.
- **Deteriorated Surface Coating, Smooth-Surfaced Composition Base Flashing:** Seal all cracks, holes, and open seams in base flashing, as noted above, prior to application of surface coating. Apply aluminum coating to all exposed existing base flashing.

### **13. METAL ROOF EDGES (GRAVEL STOPS)**

Typical problems with metal gravel stops are splits in the roof membrane at the gravel-stop joints, separation of stripping from the gravel-stop flange, and deterioration of the gravel-stop metal. Splits and delaminations between the metal gravel stop and the roofing membrane are the result of differential thermal expansion. Deterioration is often the result of roof drainage across the gravel stop.

Repair procedures are the following:

- **Splits at Seams:** Remove surface material and flood coat a minimum of 9 inches from the edge of the gravel stop and 6 inches from the gravel-stop joint. Cut away deteriorated stripping. Clean and solder open joints. Refasten loose sections of gravel stop with corrosion-resistant nails, 3 inches on center, staggered. Install two-ply cement and fabric patch, lapping the gravel stop 3



- inches and sound roof membrane 6 inches.
- **Repair Stripping:** Spud surface material and flood coat a minimum of 9 inches from the edge of the gravel stop. Remove deteriorated stripping. Refasten loose edges of gravel stop with corrosion-resistant nails, spaced 3 inches on center, staggered. Install two-ply cement and fabric patch, lapping the gravel stop 3 inches and the sound roof membrane 6 inches.
  - **Replace Deteriorated Gravel Stop Section:**
    - Remove surface material and stripping to a minimum of 9 inches from the face of the deteriorated gravel stop.
    - Remove and dispose of the deteriorated gravel stop.
    - Install new gravel stop of same material and profile. Set it in a 1/8-inch-thick bed of roof cement and secure it with compatible, corrosion-resistant nails, spaced 3 inches on center, staggered. Lap joints 3 inches. The bottom edge of the fascia (vertical leg of gravel stop) should be hooked to a securely fastened continuous cleat.
    - Strip in with two plies of cement and fabric and apply surface material.
  - **Clean, Prime and Paint:** If gravel stop is painted, clean, prime and paint deteriorated surfaces. Wire brush loose rust and paint down to bare metal and apply rust-inhibitive primer recommended by the manufacturer for the metal being primed. Allow to dry, then apply first and second paint coats.

## **SECTION E MODIFIED-BITUMEN ROOF MEMBRANES**

Modified-bitumen roofing, due to its ease of installation, is gaining in popularity on low-slope roofs. The material is either torch-applied or set in hot asphalt and is similar in appearance to smooth or mineral-surfaced roofs, except it is much thicker. The additional thickness of membrane is visible at the exposed seams. Torch repairs to modified-bitumen membranes are normally contracted out to a professional roofing contractor.

### **1. BASIC REPAIR MATERIALS AND SPECIAL TOOLS**

The following are the basic repair tools for modified-bitumen membrane repairs:

- Mastic as approved by membrane manufacturer;
- Membrane, same as installed material;
- Heat-welding torch;
- Cement and fabric. (See Built-up Roofing material list at Section D.1.)

## **2 OPEN SEAMS**

One of the main drawbacks of modified-bitumen systems is the frequent failure of both membrane and base-flashing seams. This can lead to extensive leaks in single-ply systems. Lap-seam failure can result from thermal stress and improper material application. Lap-seam repair should be done with the following procedure:

Slice failed lap seam with a hook-blade knife; clean and dry lap area. Torch unbonded lap to seam the existing material. Roll with heavy-weighted hand roller to bond as best as possible prior to stripping in. Cut stripping ply with rounded corners measuring 10 inches wide and four inches longer than the lap seam to be repaired. Prepare membrane surface by sweeping and applying asphalt primer. Allow primer to cure. Center stripping ply over seam and torch-apply. Heat to produce flow of 3/8 to 5/8-inch outside the edge of the patch.

These repairs require contract work unless there are properly trained roofing professionals on the HA staff. Temporary repairs may be made with two-ply cement and fabric patches. Check compatibility of roofing cement and membrane with membrane manufacturer.

## **3. SURFACE DETERIORATION**

Loss of mineral surfacing or smooth-surface coating on mineral-surfaced modified-bitumen membranes can lead to accelerated deterioration of the asphalt and reinforcements in the modified membrane. Causes of surface deterioration can include foot traffic and natural weathering. Repair procedures are as follows:

- **Mineral Surfacing Repair (Small Areas):** Sweep surface and salvage existing loose mineral surfacing. Apply a bed of approved mastic to the area to be resurfaced. Broadcast heavy coating of mineral surface material over mastic and press into place.
- **Mineral Surfacing Repair (Large Areas):** If there has been granule loss throughout the roof, sweep surface to remove all existing loose mineral and apply protective coating in accordance with membrane manufacturer's specifications.
- **Smooth Surface Repair:** Repair the exposed surface of the membrane, sweep clean, and apply protective coating in accordance with membrane manufacturer's specifications.

## **4. BASE FLASHING DEFICIENCIES**

See Built-up Roofing section.

## 5. HOLES

Punctures through the roofing membrane can be caused by vandalism, foot traffic, falling tree limbs, or other similar events. For repair procedures, see seam-repair procedure in Section E.2.

## 6. BLISTERS

See Built-up Roofing section. Patch locations where blisters are removed with modified-bitumen roofing membrane.

## SECTION F ROLL ROOFING

Roll roofing consists of asphalt-impregnated roofing felt coated with a mineral surfacing. The roof is installed in shingle style on sloping, nailable roof deck and is fastened with roofing nails. This type of roof is not common.

### 1. OPEN SEAMS

Open seams are caused by failure to cement seams or to use the proper kind of cement.

Use the following repair procedure:

- Cut all buckles and fishmouths which terminate at seams.
- Replace loose or missing nails.
- Sweep mineral surface material from the area to be repaired and salvage. Apply asphalt primer or work first layer of roofing cement well into the membrane.
- Extend roofing cement a minimum of 3 inches on either side of seam to be repaired. Embed 4-inch wide strip of cotton roofing fabric into the cement.
- Apply second coat of roofing cement and broadcast liberal amount of mineral surfacing into completed repair.

### 2. HOLES

Holes are punctures or tears in the roofing membrane, which may be the result of foot traffic, falling debris, and vandalism. Follow this repair procedure: sweep the area to be repaired of loose mineral surfacing material and apply two-ply cement and fabric patch.

## **SECTION G METAL ROOFS**

There are numerous kinds of metal-roof systems available today. Metal roofs are generally limited to porches, cornices, penthouses, and other small structures. The metals used in these roofs are copper, lead coated copper, stainless steel, terne-coated stainless steel, terne plate, and galvanized steel. The most common types are standing-seam and flat-locked and soldered seam roofs. If an HA has a prefabricated metal roof, the system manufacturer should be contacted for maintenance requirements unless the information is already on file.

The metal roof repairs listed below are best made by skilled sheet-metal mechanics and professional roofing contractors. Therefore, the repairs will have to be contracted out.

### **1. BASIC MATERIALS**

Materials for metal roof repairs include the following:

- Copper: ASTM B 152, C110 cold rolled, tempered, 16 or 20-ounce. Match existing materials.
- Lead-Coated Copper: ASTM B 101, Type I, Class A, coated one side, except coated both sides where both exposed; cold-rolled unless soft temper required for forming and performance; 16-ounce sheet before coating (0.0216 inch thick).
- Neoprene: Uncured neoprene, 60 mils thick; specific gravity (ASTM D 297) 1.50 + .05; tensile strength 1400 psi; density 0.50 psf. Use adhesives and sealants supplied by neoprene manufacturer.
- Paint System (for copper): Primer: Epoxy polyamide, highly corrosion and chemical-resistant lead silico-chromate primer, two-part mix, solids content 68 percent by weight, color-dull orange, recoat within 72 hours. Apply at the rate of 400 square feet per gallon or 2 mils dry-film thickness (Ply-Tile 520-R-17 Primer by MAB or equal). Finish Coat: Aliphatic Acrylic Urethane, two-part mix, solids content 59 percent by weight, color—Vista Green C60-63 Y. Apply at 350 square feet per gallon or 2.5 mils dry film thickness (Ply-Thane 880 Coating by MAB or equal). (Contact MAB, 600 Reed Road, Broomall, Pennsylvania (Phone 215/353-5100) for nearest distributor.)
- Solder: ASTM B 32, 50-50 percent block tin and pig lead (minimum) solder. Use rosin flux. Use 3 pound irons. Do not use torches or welding for metal roofs.
- Stainless Steel (SS): Type 304, ASTM A 167, with AISI 2D finish, dead soft, fully annealed, 0.018 inch thick, except as otherwise indicated.
- Terne Coated Stainless Steel (TCS): Type 304, ASTM A 167, dead soft stainless steel coated on both sides with terne alloy (80% lead and 20% tin); match thickness of material being patched, 0.015 inch thick minimum. (Terne Coated Stainless Steel by Follansbee).

## 2. METHODS AND TECHNIQUES

When performing inspection or repairs on metal roofs, workmen should wear rubber-soled shoes to prevent damage to the roof.

### a. Solder Repair

Clean existing metal of all roofing cement, paint, coating, and rust to bright clean metal for one inch around small hole. Solder hole watertight.

### b. Soldered Metal Patch

Clean existing metal of all roofing cement, paint, or other coating and rust to bright clean metal for two inches around damaged area. Cut metal for patch to 1/8-inch smaller than cleaned area. Pre-tin patch and cleaned surface at repair area. Solder patch watertight (Do not use torches or welding). Use pop rivets (same material as roof) on larger patches to aid in soldering operation. Clean excess rosin and neutralize flux.

### c. Neoprene Repair

Clean all adhesive, cement, dirt, and oil from seams to be repaired. Center 2-inch wide bond breaker, polyethylene backer from neoprene or duct tape, over damaged seam. Apply a neoprene patch, with bonding adhesive applied to both surfaces. Lap the open seam a minimum of 4 inches on all sides. Roll patch with a hand roller until it is completely in contact with the metal roofing and does not bridge at any point. Seal the patch edges with polyurethane sealant and coat exposed surface of neoprene with Hypalon or equal.

### d. Clean, Prime, and Paint

Wire brush rust down to bare metal and remove loose paint from metal roof panels. Patch open seams or damaged sections of metal roof using appropriate repair procedures (see Section G.2). Apply rust-inhibitive primer recommended by manufacturer for metal to be painted. Allow to dry and apply first and second finish coats of paint. Record paint information in Historical Data File.

### e. Coating Eroded Surfaces (typical for copper roofing)

Repair holes and open seams in accordance with appropriate repair procedures. Clean, prime, and paint eroded areas with paint system for copper, following manufacturer's recommendations.

### **3. HOLES**

Holes in metal roofs can result from corrosion, erosion, natural weathering of metal, foot traffic, impact of falling objects, or from other causes. Repair procedures include the following:

- Patch small hole (less than 1/8-inch diameter) in accordance with Solder Repair techniques described above.
- Patch large hole (greater than 1/8-inch diameter) in accordance with Soldered Metal Patch technique described above.

### **4. OPEN SEAMS**

Open seams in flat-locked and soldered metal roofing result from expansion of the metal roof when it is exposed to the summer sun. Repair procedure is as follows:

- Patch open seam in metal roof in accordance with Soldered Metal Patch technique above.
- Only if soldered patches are unsuccessful or if damage results from lack of expansion joints and expansion joints cannot be added, repair in accordance with Neoprene Repair technique described above.

### **5. CORROSION AND EROSION**

Corrosion occurs when aluminum or ferrous metal surfaces are exposed to weathering or when different metal materials are in contact. Erosion results from concentrated water flowing over the metal surfaces, such as valleys and crickets, and is confined to copper roofing materials. The repair procedure is as follows:

- Clean, prime, and paint painted metal surface where deterioration has started or paint is cracking, peeling, or otherwise in poor condition.
- Repair eroded metal surfaces in accordance with Coating Eroded Surface techniques described above.

### **6. FASTENER DEFICIENCIES**

Fastener deficiencies arise when fasteners become loose. Corrosion develops when fasteners of incompatible metals are in contact, and when ferrous fasteners are exposed to the weather. Repair procedures are as follows:

- Loose Fasteners: Check all exposed fasteners for tightness. Tighten loose screws. If screws are stripped, replace them with new screws with neoprene washers. Use fasteners which are corrosion-resistant and compatible with the metal being fastened.
- Corroded Fasteners: Remove corroded fasteners and replace them with new corrosion-resistant

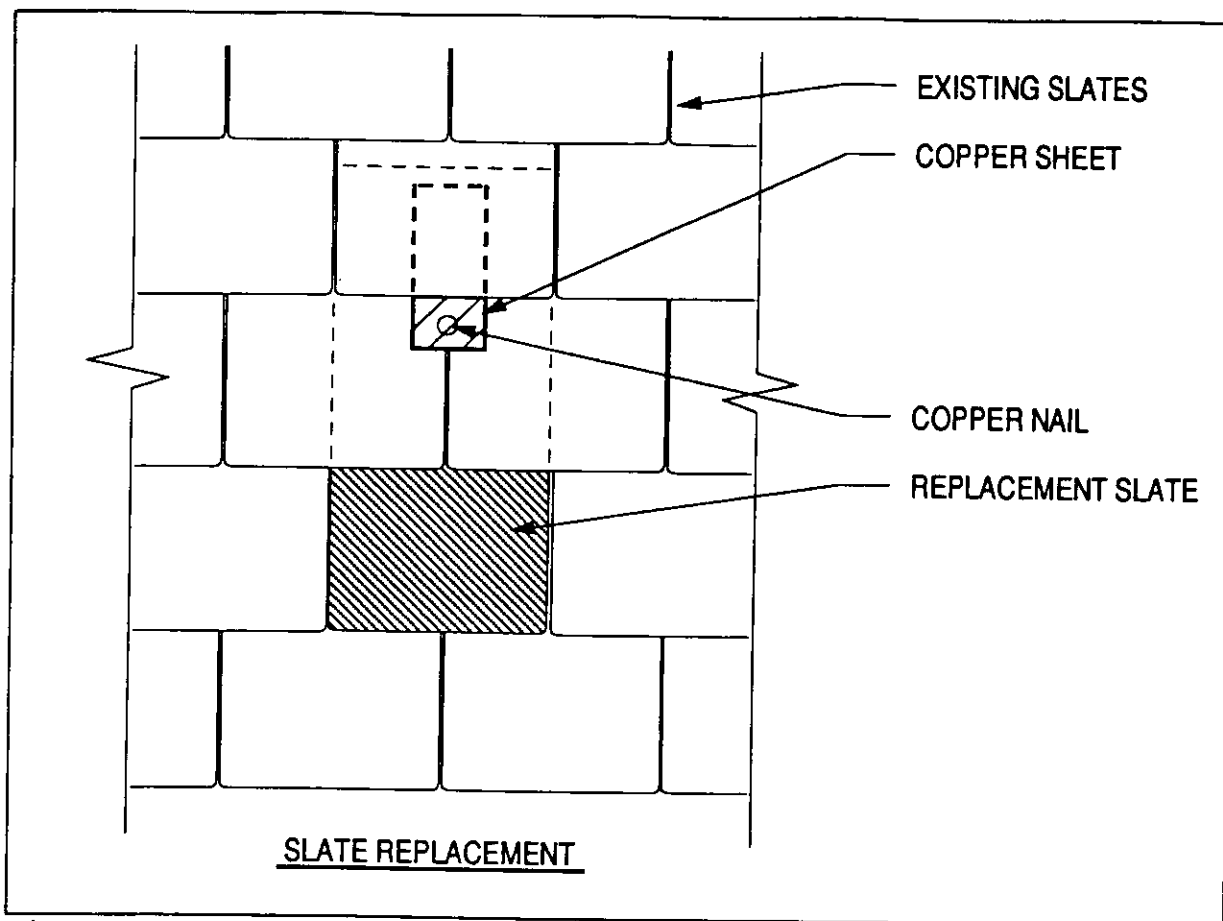

Figure 5-5: Slate Replacement Plan

fasteners compatible with metal to be fastened. Screws should be installed with neoprene washers. Where nail heads will remain exposed, cover with neat spots of polyurethane sealant.

## SECTION H SLATE, TILE, AND OTHER RIGID ROOFING SHINGLES

Slate, tile, and cement-asbestos shingles are rigid roofing materials generally used on pitched or sloping roofs. These materials normally provide long service lives with little or no repair. However, being brittle and rigid, they are frequently susceptible to damage from hail, foot traffic, tree limbs, high winds, and thrown objects.

### **1. REPAIR OR REPLACEMENT OF MISSING, BROKEN, OR LOOSE TILES**

If repair or replacement is necessary, fasten shingles with copper nails long enough to penetrate the substrate sheathing, or about 1/2-inch. Nails should just touch shingle slightly. DO NOT drive the nails "home" or draw down the shingle. Replace broken or missing slates which allow water to enter the building (slates which are broken or have large cracks extending over joint between slates underneath), using the following repair procedure.

**a. Slate (and Other Flat, Rigid Shingles)**

Carefully remove broken slate shingle, cut the nails with a ripper, and remove remaining small pieces of slate. Insert new slate, matching the existing slate in size and color. Using copper nails, fasten replacement slate through vertical joint of overlying course about 2 inches below the tail of the overlying course. Insert over this nail a 3x8 inch sheet of copper, bent slightly, to fit snugly under the slate above and cover the nail. (See Figure 5-5.)

**b. Tile**

Lift the tile up-slope of the tile to be replaced, and install a copper nail into the substrate. Insert copper wire into replacement tile fastener hole and twist wire to secure it to tile. Slide tile into place and wrap wire around new nail and twist to secure. (See Figure 5-6.)

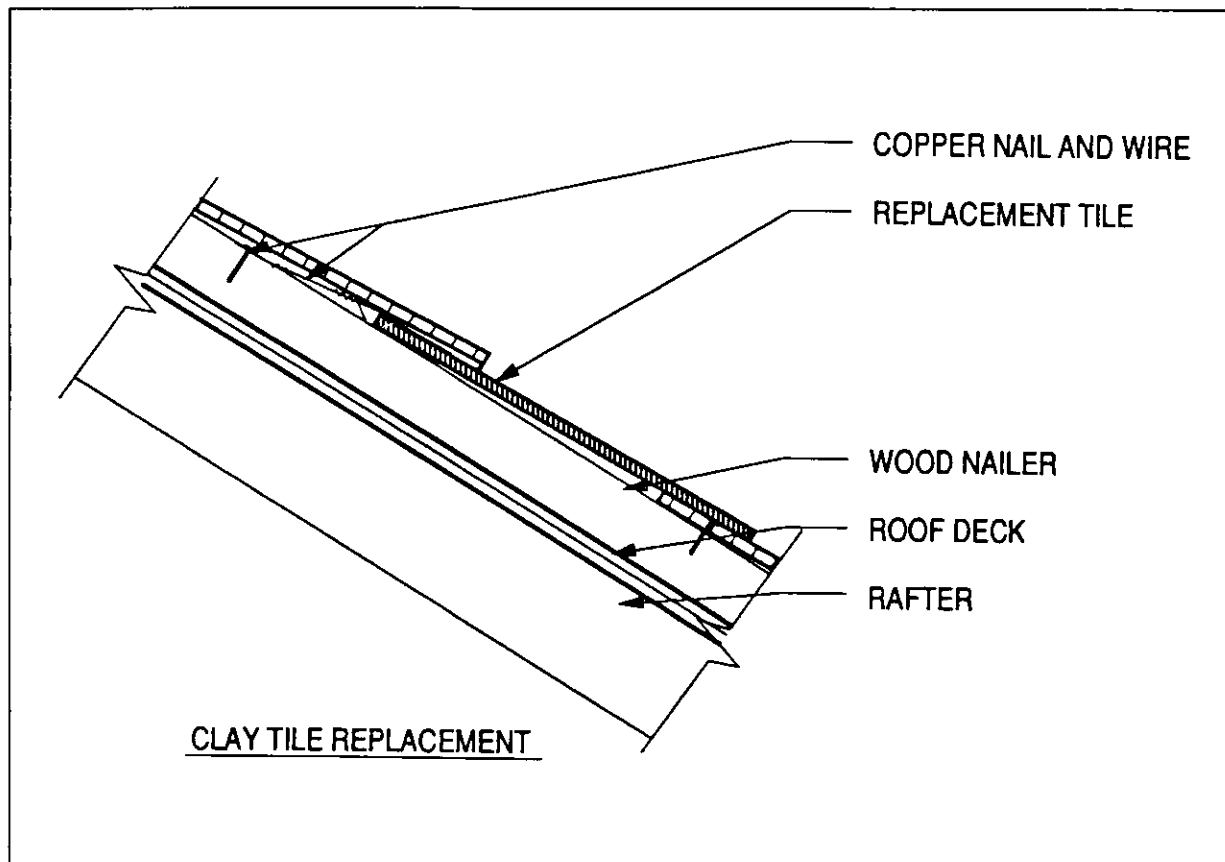

Figure 5-6: Tile Replacement Section

**2. DETERIORATED FELT UNDERLAYMENT**

The cause of deteriorated felt underlayment is usually extended exposure to weather at missing and broken tiles. Replace deteriorated felt underlayment encountered as follows.

- Small Areas (less than 2 SF): Cut away deteriorated felt underlayment, clean substrate and



- **Small Areas (less than 2 SF):** Cut away deteriorated felt underlayment, clean substrate and surrounding felt at tie-in. Prime substrate with a thin coat of asphalt primer and allow to dry or work roofing cement well into underlayment. Apply 1/16-inch thick bed of roof cement, embed one layer of fabric reinforcing and cover with a second 1/16-inch thick layer of roofing cement. Extend patch a minimum of 3 inches onto sound underlayment.
- **Large Areas (greater than 2 SF):** Cut out and remove deteriorated underlayment. Cut square with roof. Make two 3-inch long slices at top edge corners of sound underlayment to remain to create flap, and slide new felt up under the existing. Fasten new underlayment with one nail per two square feet, and seal edges of new underlayment and nail heads with roof cement. If more than one width of underlayment is installed, start installation at lowest point and install in shingle fashion lapping each width 3 inches.

## **SECTION I ASPHALT SHINGLES**

Asphalt shingles are among the most common steeply-sloped roofing materials because of their low maintenance requirements, low initial cost, and ease of installation. The first indication of normal weathering is loss of mineral surfacing granules, slight at first, but accelerating as loss of granules exposes more of the asphalt coating. Other effects noticeable on aging shingle roofs are curling and cracking.

### **1. BASIC MATERIALS**

The following are the three basic materials required for the repair of asphalt shingles:

- **Asphalt-Fiberglass Shingles:** UL Class A fire-resistance rating. Match color, dimension, and thickness of existing shingles. Use same shingle as originally installed, if possible.
- **Nails (Roofing):** Galvanized steel, annular or spiral threaded, 11-gage roofing nails.
- **Roof Cement:** See Built-up Roofing Repair Material.

### **2. SINGLE SHINGLE REPLACEMENT TECHNIQUE**

Raise shingle above the damaged shingle, taking care not to damage the existing sound shingle. Remove nails with pry bar, chisel, or slate ripper. Slip new shingle into place. Holding up shingle above, nail replacement shingle into place. Apply dab of roof cement at tabs (3 to 4 one-inch diameter dabs). Cutting top corners of the replacement shingles at a 45 degree angle can ease the installation when sliding them under existing shingles.

### **3. FASTENING PROBLEMS**

Some of the problems associated with improperly fastened shingles are lifting during normal winds, tearing at fasteners, and loss of shingles. Damage may also result from high winds lifting end tabs of properly fastened shingles. Some causes include nails installed too close to top of shingle; nails driven at an angle cutting the shingle; staples driven through shingles; insufficient fastener penetration into substrate. Correct these problems using the following repair procedures:

- **Missing or Loose Shingles:** Repair in accordance with Single Shingle Replacement Technique (Section 1.2 above).
- **Loose End Tabs:** Apply 1 1/2-inch diameter dab of roofing cement below loose tab and press tab into roofing cement.
- **Ridge Wind Damage:** Check that ridge shingles are lapped with, rather than against, direction of prevailing wind. Replace damaged ridge shingles, or if they are installed in the wrong direction (shingle ends against prevailing wind direction), replace the entire ridge.

### **4. SMALL ASPHALT SHINGLE AREA REPLACEMENT**

Small area replacement is an effective means of restoring a partially deteriorated or damaged asphalt shingle roof that is otherwise in good condition. Shingles can be blown off by high winds, punctured by hail or other objects such as protruding nails. Use the following repair procedure:

- Remove all loose, deteriorated, and damaged shingles;
- Remove all loose and protruding nails;
- Remove and replace damaged underlayment (felt) similar to procedure outlined above. Cut out and replace damaged or deteriorated wood decking. Replace decking (sheathing) with material of same thickness so that deck will be even with adjoining area.
- Install replacement shingles. Install top row in accordance with Single Shingle Replacement Technique.

### **5. WOOD TRIM AND WOOD EAVE REPLACEMENT**

Rotted wood can result in leaks into the interior of the building and deterioration of connected wood elements. Among the causes are gutter back-up or leaks, improper extension of shingles beyond edge of roof, lack of a metal drip edge, and ice dams. Use the following repair procedures:

- Remove and store gutters if applicable;
- Remove first three courses of shingles. Remove additional shingles to expose sound decking as necessary (see Single Shingle Replacement Techniques);
- Remove deteriorated wood decking and replace with new decking of same thickness;
- Cover new deck with felt underlayment;

- Install metal drip edge;
- Install replacement shingles in accordance with Small Area Replacement.

## 6. INADEQUATE VENTILATION

Cupping and curling of asphalt shingles is sometimes the result of inadequate ventilation between the building interior and the roof deck. Asphalt Roofing Manufacturers Association (ARMA) recommends a minimum of one square foot of ventilating area (grating) per 150 square feet of attic space. Check existing conditions and make provisions to increase ventilation where necessary to meet these requirements. Repair shingles as noted above.

## 7. REROOFING WITH ASPHALT SHINGLES

Excessively deteriorated shingles should be replaced. Guidelines for shingle roof installation have been developed by the National Roofing Contractors Association (NRCA) and the Asphalt Roofing Manufacturers Association (ARMA). Contact NRCA or ARMA at addresses listed in Appendix C.

## SECTION J COUNTERFLASHING

Cap or counterflashing, usually metal, serves as a protecting cover for the base flashing. The counterflashing should extend over and completely cover all flashing strips, nails, and fasteners securing the top of base flashing by 3 to 4 inches. Some typical counterflashing installation methods are illustrated in Figures 5-7 through 5-9.

### 1. TWO-PIECE COUNTERFLASHING

Two-piece counterflashing consists of a removable "counterflashing" which is attached to a "receiver." The receiver is either inserted into a reglet in the wall above the base flashing or is the outer edge of a through-wall flashing. The seams in the counterflashing receiver should be soldered watertight. Typical deficiencies with two-piece counterflashing are failure of the connection between the two flashing sections, and deterioration at the joint where the receiver meets the wall.

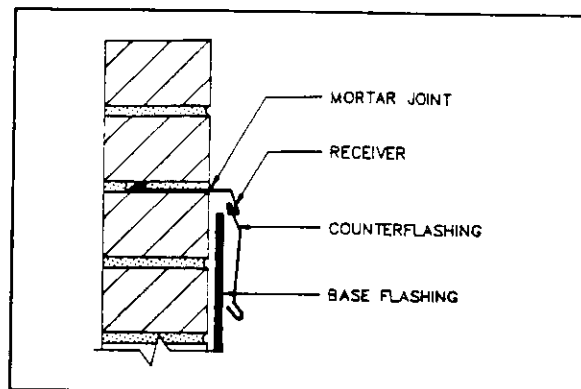

Figure 5-7: Reglet-Mounted Two-Piece Counterflashing

Causes include differential thermal movement between wall and counterflashing receiver, poor original installation, or lack of maintenance, for instance, counterflashing that is not reattached when it becomes loose. Repair procedure is:

- Reattach loose or fallen counterflashing to receiver with compatible, corrosion-resistant sheet-metal screws with neoprene washers, spaced 16 inches on center.
- Repoint deteriorated mortar joints above receiver (see Mortar Repointing repair below). **DO NOT** seal joint above receiver with sealant; this will prevent drainage of water from the wall.

## 2. REGLET-MOUNTED COUNTERFLASHING

Reglet-mounted counterflashing can be single-piece or two-piece counterflashing. Typical deficiencies with reglet-mounted counterflashing are deterioration of the reglet joint, too-shallow embedment into wall, and poor securement of flashing to wall.

Causes include differential thermal movement between wall and counterflashing receiver, poor original installation, and lack of maintenance, such as not resealing the joint between the wall and counterflashing. Use the following repair procedures:

- Secure or reset loose counterflashing in the reglet with lead wedges, and repoint with mortar.
- Replace missing counterflashing with new matching material, size, and profile of existing counterflashing.
- Replace counterflashing that is in a too-shallow reglet. Saw-cut reglet at 3/8-inch wide and 1 1/2-inch deep. Fabricate and install new two-piece counterflashing with 1 1/2-inch leg set into reglet. Secure with lead wedges and point with mortar.

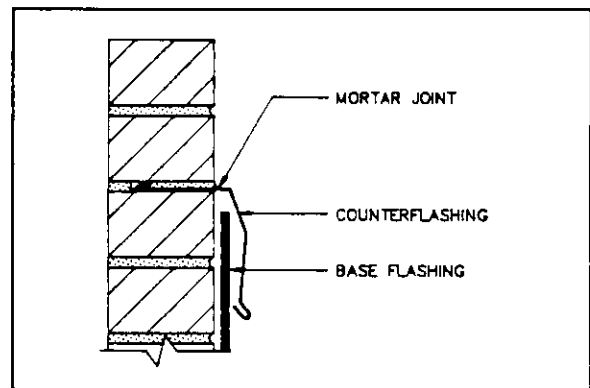

Figure 5-8: Reglet-Mounted One-Piece Counterflashing

## 3. SURFACE-MOUNTED (PHILADELPHIA) COUNTERFLASHING DEFICIENCIES

Surface-mounted metal counterflashing is secured to the wall with nails or other similar fasteners (there is no reglet), and sealed along the top edge with sealant. Surface-mounted counterflashing should not be used on masonry walls because any water penetrating the mortar joints can seep behind base flashing. Typical deficiencies with surface-mounted counterflashing are failure of sealant at the edge of flashing and leaks at fasteners that penetrate the base flashing.

Use the following repair procedure:

- Cut away all failed sealant, and clean surfaces to receive new sealant in accordance with sealant manufacturer's specifications. Install new, neat bead of weather-resistant sealant at the top of counterflashing. DO NOT smear excessive amounts of sealant onto surrounding wall or counterflashing surfaces. Tool surface of sealant to a concave shape that will allow water to drain away from wall.
- Secure loose counterflashing with nails spaced 12 inches on center. Seal tops of new and existing fasteners with neat dab of sealant.

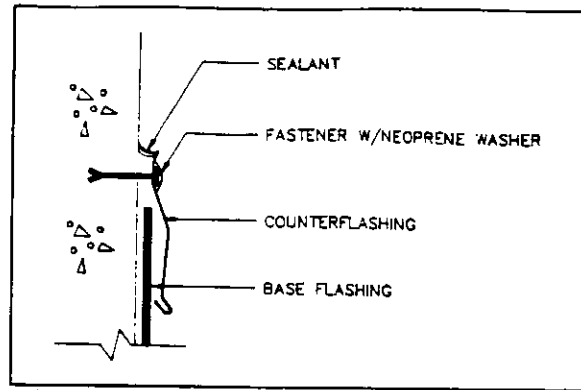

Figure 5-9: Surface-Mounted Counterflashing

#### 4. CORROSION OF COUNTERFLASHING

Causes of corroded counterflashing include lack of protective paint on ferrous-metal counterflashing, and concentrated flows of water over copper counterflashing. Serious corrosion of counterflashing is an infrequent occurrence. Follow this repair procedure:

- Clean, prime, and paint in accordance with technique listed under Metal Roofing section.
- Coat eroded surfaces in accordance with technique listed under Metal Roofing section.

### SECTION K VALLEYS

Roof valleys are formed when two sloping roof sections join to form a "V." Because water flow is concentrated in the valley, valley flashing should be adequately sized. Valleys are constructed of metal, roll roofing or shingles. The valley flashing discussion below addresses only metal valleys. Typical deficiencies associated with valley flashing are leaks at seams and holes, inadequate side laps under roofing materials, corrosion, and erosion.

#### 1. HOLES AND PUNCTURES

Holes and punctures are caused by foot traffic, falling objects, and erosion, among other causes.

Repair in accordance with Soldering and Sheet Metal Patch techniques in the Metal Roofing section.

## **2. CORROSION AND EROSION**

Two causes of corrosion and erosion are a lack of coating maintenance on ferrous-metal valleys and concentrated flow of water over copper valleys. Use the following repair procedure:

- Repair in accordance with Clean, Prime, and Paint and Coating Eroded Surfaces techniques in the Metal Roofing section.
- Reline: Heavily eroded valleys should be relined in accordance with Gutter Lining technique in the Drains, Gutters, and Downspouts section. It is not a good practice to coat metal flashing with roofing cement. The roofing cement accelerates erosion, inhibits future repairs, and generally fails after only a few thermal cycles.
- Replacement: Remove roofing materials adjacent to valleys in accordance with small area repairs. Fabricate and install valleys in accordance with Sheet Metal and Air Conditioning Contractors Association (SMACNA) and NRCA details.

## **3. LAP-JOINT LEAKS**

Lap-joint leaks are caused by an inadequate lap between valley flashing sections, and debris on the valley or at the gutter, which causes water, snow, or ice to back up. Correct by cleaning debris or other materials inhibiting water flow in valley. Clean lap-joint surfaces and install a bead of sealant.

## **SECTION L PARAPETS**

Although parapets are not a part of the roofing system, problems at parapets often directly affect the performance of the roof. The most common problems include inadequate slope of coping (top surface should be sloped to drain toward the highest roof section adjacent to the coping), poor quality or deteriorated mortar joints, failed masonry coping joints, non-watertight metal copings, lack of through-wall flashing below masonry coping, and deteriorated masonry coping stones.

### **1. COPING-JOINT LEAKS, GENERAL**

Inadequately sealed coping joints can allow water to penetrate the roofing system. Confirm that there is through-wall flashing and that base flashing extends over top of parapet wall below coping. If there is through-wall flashing or the membrane base flashing extends over the top of the wall, there is less need for concern over the condition of the coping joints. The causes of coping-joint leaks are thermal expansion and contraction of coping materials, and poor original construction.

## **2. REPAIR PROCEDURES, METAL COPING**

### **a. Joint Failure**

Check to see that coping joints meet requirements of Sheet Metal and Air Conditioning Contractors National Association (SMACNA) if they are required to be watertight. Joints will either be lapped, butted with back-up and cover plates, lapped and soldered, or standing seamed.

- Repair broken solder joints in accordance with Soldered Metal Patch technique in the Metal Roofing section.
- Repair open sealant joints by cutting away all failed sealant and cleaning both sides of joint to receive new sealant. Install new polyurethane sealant.

### **b. Metal Coping Corrosion**

Clean, prime, and paint in accordance with technique listed in the Metal Roofing section.

## **3. REPAIR PROCEDURES, MASONRY COPING**

### **a. Joint Failure**

Cut out failed mortar and sealant joints and install backer rod and sealant. Repoint bed joints with mortar.

### **b. Masonry Coping Deterioration**

If there is no through-wall flashing, consider removing the coping, installing through-wall flashing, and replacing the coping stone with new material. If it is not practical to remove stone, consider covering coping with sheet-metal coping designed by an Architect or Engineer. Fabrication and installation should be performed by a professional roofing contractor.

## **4. DETERIORATED MORTAR JOINTS IN PARAPET WALLS**

Causes of deteriorated mortar joints in parapet walls may include thermal movement, poor quality mortar, and trapped moisture. For repair, see Repointing technique in Waterproofing Repair section.

## **SECTION M DRAINS, GUTTERS, AND DOWNSPOUTS**

### **1. LEAKS AT DRAINS**

Leaks at drains normally result from failed roof-drain flashing, improperly fastened or broken clamping rings, condensation from uninsulated roof drains and piping, deteriorated piping, and poor pipe connections. Repair in the following ways:

- **Clamping Ring Repair:** Replace broken or missing roof-drain clamping ring, clamps, and bolts with cast-iron components. Extract stubs or drill and tap threads, if necessary, to fasten clamping ring bolts.
- **Restrip Roof Drain Flashing:** Spud and clean loose and deteriorated material and debris from roof drain stripping. Be careful not to damage lead flashing. Restrip with two-ply cement and fabric. Do not build dam around drain.
- **Replace Roof Drain Flashing:** Carefully remove roof-drain clamping ring, stripping, and lead flashing down to surface of original membrane. Prepare surface of existing membrane, strip into existing drain in accordance with membrane manufacturer's recommendations for new drain installations, and reinstall clamping ring. Drill and tap threads if necessary. Do not build a dam around drain. This work should be contracted out to a professional roofing contractor.
- **Replace broken or missing roof-drain domes, screens, or strainers** with cast-iron components, to match existing size.
- **Insulate roof-drain body and piping** with heavy density, 1-inch thick insulation with embossed aluminum foil and laminated PVC vapor barrier. Tape all joints.
- **Replace Failed Roof Drains:** This is specialty work and should be performed by a competent plumber familiar with roof-drain installation. **DO NOT** install plastic (PVC) drains or metal drains that do not have clamping rings.

### **2. GUTTER LEAKS**

Gutter leaks are caused by failure of gutter seams due to inadequate expansion joints and thermal movement; loose, insufficient supports; improper slope; inadequate sizing; ice formations; or overloading due to clogged outlets. Repair procedures are as follows:

- Check gutters during heavy rain to see if they are overflowing. If they are, and the downspouts are clear, have sizing of system checked by a consultant.
- Repair holes and open seams in gutters in accordance with Soldering and Sheet Metal Patch techniques in the Metal Roofing section.
- Repair open gutter seam with neoprene (moving joint): Perform repair in accordance with Neoprene Repair technique described in the Metal Roofing section.
- Refasten loose gutter with compatible gutter spikes or appropriate brackets for existing gutter



style.

- Re-slope gutter: Remove and reinstall existing gutters that have reverse (negative) slope toward the outlet. Set to a 1/16-inch per foot minimum slope.
- Reline Gutters: Reline structurally sound gutters with numerous holes and open joints. Line deteriorated portion of gutter with cured EPDM set in bonding adhesive. Lap joints 4 inches.
- Clean, prime, and paint ferrous-metal gutters and downspouts on a regular basis in accordance with Clean, Prime, and Paint technique described in the Metal Roofing section.

### **3. DOWNSPOUT DEFICIENCIES**

Often downspouts are either not secured to gutters or building walls or are inadequately secured. As a result, they slip down or become clogged or damaged. Sometimes they are removed by an unauthorized person. Such downspouts can result in improper roof drainage or water being discharged onto the building walls. Repair procedures include the following:

- Clean all debris from downspouts. Carefully and neatly disconnect downspouts if necessary. Use slip connector to make joint watertight after cleaning.
- Re-secure existing downspouts to masonry wall with compatible hangers and fasteners, 6 feet on center maximum. Refasten existing downspout to gutter outlet tubes with compatible pop rivets or compatible metal screws, then seal.
- Remove and replace damaged or missing downspout sections, including transitions, with new downspouts to match existing. Use four rivets at each joint, two in front and one on each side. Downspout sections shall penetrate lower sections and storm-drain boots 1 1/2-inches minimum. Use compatible hangers and fasteners to secure downspouts to wall.
- Install concrete splash block under downspout unless downspout is connected to a drain pipe.
- Clean drain pipe if clogged.

## **SECTION N MISCELLANEOUS PENETRATIONS AND ROOF-TOP EQUIPMENT**

Industry-recommended flashing details for miscellaneous penetrations are contained in the NRCA Roofing and Waterproofing Manual for most common types of roof membranes. A copy of these details should be compared to the existing installations, and, where possible, the existing installations should be upgraded to meet the minimum requirements in the manual.

### **1. PITCH-PAN LEAKS**

Leaks can occur at pitch pans due to shrinkage of the pitch-pan filler. Topping off of pitch-pan filler is a constant maintenance problem. Therefore, if at all possible, pitch pans should be eliminated from

the roof and replaced with sheet-metal piping enclosures or with boots with rain shields positively sealed to the penetrating object, using details in the NRCA Roofing and Waterproofing Manual.

Repair procedure is as follows:

- Fill existing pitch pans with roofing cement or pitch-pan filler, whichever is existing. Remove insulation from piping 2 inches above pitch-pan filler. Separate wires, pipes, and conduit (1/2-inch diameter, minimum). Clean item to be flashed to a bright, clean metal for a minimum of 2 inches above the pitch pan. Apply filler material and slope surface for positive drainage out of the pitch pan.
- Remove Pitch Pans: Cut off existing steel supports at roof deck and remove supports, framing, and pitch pans. Patch surface of membrane in accordance with appropriate repair procedure, depending on type of roof.

## **2. VENT PIPE LEAKS**

Vent pipe leaks result from incomplete and open flashing, and from worn or deteriorated stripping.

Repair procedure is as follows:

- Tall Vent Pipes: Seal top of vent pipe flashing with two plies of cement and fabric or install a sheet-metal rain shield with band clamp and sealant joint.
- Normal/Short Vent Pipe Caps: Install watertight caps of copper, stainless steel, or lead, whichever is compatible with the vent pipe and existing boot flashing. Lap existing sound flashing a minimum of 2 inches. Turn cap down 1 inch into pipe.
- Restrip Vent Pipe Flashing: Remove deteriorated membrane, and patch in accordance with appropriate membrane-patching procedure.

## **3. EQUIPMENT-SUPPORT DEFICIENCIES**

Improper equipment supports can result in accelerated deterioration of the roofing membrane and inhibit roof maintenance, inspection, repair, and drainage. Supports may be too low or rest directly on the roof membrane with no protective pad. If possible, remove equipment supports and install new support in accordance with membrane manufacturer and NRCA recommendations. Connect supports directly to roof deck, flash penetrations, and re-install equipment. The support should be designed by a structural engineer.

## **SECTION O INSULATION**

Roof-top insulation is fabricated from a variety of materials, which all have differing insulating values, compatibility, and fastening requirements. There are two types of insulation, absorbent and nonabsorbent. When absorbent insulation becomes wet, it must be removed from the roof and replaced with dry insulation.

### **1. WET INSULATION**

Wet insulation contributes to accelerated deterioration of roof membranes, loses its thermal insulating value, and adds to the dead load on the roof. Causes include failures and defects in the roofing membrane, flashings, and walls. Use the following repair procedure:

- Identify general areas of wet insulation by nondestructive testing, and mark locations on the roof.
- Cut out membrane and remove wet insulation. Extend areas marked on the roof as required to remove all wet insulation. Prepare surface of surrounding membrane for patch. Replace deteriorated membrane and patch in accordance with appropriate membrane-patching technique described previously.
- Outside assistance will be required for detection, removal, and replacement of wet insulation and patching damaged roof membrane.
- If more than 25 percent of the roof insulation is wet, the HA should consider replacement of the entire roofing system.

## **SECTION P DECK REPAIRS**

In performing roof repairs, deteriorated deck is often encountered. Also, examination of the underside of roof decks may reveal areas of deterioration requiring repair that would otherwise have gone unnoticed. To perform deck repairs, see specific membrane type for cutting repair procedures related to cutting and patching membranes. When deck deterioration is encountered, a structural engineer should inspect the roof deck and provide repair recommendations.

### **1. WOOD DECK**

Deteriorated wood deck, including supports, normally results from roof leaks; however, some wood-deck repairs may be required as a result of insect (termite or carpenter ant) damage.

The following repair procedure should be followed:

- Cut out deteriorated wood deck. Exercise care not to damage materials to remain.
- Nail new wood supports to the existing joist/rafter if required for proper support of the deck.
- Replace wood deck with new plywood or plank, matching size and thickness of the existing deck.

## **2. CONCRETE DECK**

Deteriorated concrete deck can result from poor original construction, roof leaks, or a combination of both. Small surface deterioration encountered during roof repairs can be repaired by removing deteriorated concrete and patching with a sand-cement concrete mix. Large defects should be investigated by an engineer to determine scope of the required repair work.

## **3. GYPSUM DECK**

Deteriorated gypsum deck most often results from roof leaks. Repair in the following way:

- Remove deteriorated gypsum and clean the exposed reinforcing.
- Install form at the underside of deck if deterioration extends through the deck.
- Place gypsum fill, and cure in accordance with manufacturer's recommendations.
- For small deteriorated area (less than 2 SF), lightweight concrete patching compound can be used instead of the gypsum fill material.

## **4. STEEL DECK**

Deteriorated steel deck can result from either roof leaks or condensation forming at the roof deck.

Repair as follows:

- **Small Areas (less than 2 SF):** Repair by cutting out deteriorated decking back to sound, unruled metal. Install 20-gauge sheet-metal patch extending a minimum of 6 inches onto sound deck. Fasten with sheet-metal screws, with 2 to 3 screws per side of patch.
- **Large Area (exceeding 2 SF):** Cut out deteriorated deck back to nearest support. Install new deck matching gauge and profile of the existing deck material. New deck should extend across a minimum of two supports. Fasten to joist and adjacent sound deck in accordance with steel deck manufacturer's recommendations.

## **SECTION Q WATERPROOFING**

### **1. REPOINTING**

Mortar joints provide the bond between masonry units (bricks or concrete masonry units), and form a primary layer to protect the wall against water infiltration, although the joints are porous and water seepage is not fully excluded. Sound mortar joints reduce the amount of water penetrating the wall to an acceptable level. Mortar deterioration results from thermal movement, settlement, shrinking and swelling soil and water penetration.

The corrective action generally includes removal of cracked and deteriorated mortar from masonry joints to a minimum depth of 3/4-inch, or to sound mortar. Flush joints with clean water to remove all dirt and debris and to saturate the joint before applying mortar. Allow water to penetrate masonry at the joint to be repointed so that there is no standing water in joint at the time of repointing. Apply mortar in thin (1/4-inch) layers. Each layer should become "thumb-print" hard before applying next layer. Tool joints to match adjacent existing joints. Clean all excess mortar from the face of the stone within 24 hours.

Mortar and wall deteriorations resulting from shrinking and swelling subsoils require a different method of correction which exceeds the scope of this Guidebook.

## **2. SEALANT-JOINT REPAIR**

Sealant joints are used in masonry walls to provide both horizontal and vertical expansion joints. The horizontal expansion joints, also known as "soft" joints, allow differential movement between the building structure and the brick masonry facade. The vertical expansion joints normally correspond to the building expansion joints. Sealant joints are also used to seal the perimeter of doors and windows. Failure of sealant joints often results in leaks directly into the building.

Sealant joints fail because of age and the resulting inelasticity of sealant material, improper installation (sealant must have the correct profile and depth-to-width ratio to perform properly in joints), improper surface preparation, and improper curing. Repair procedure is as follows:

- a. Full Joint Replacement:** Clean out joints immediately before installing joint sealants to comply with recommendations of joint-sealant manufacturer and the following requirements:
  - Remove all foreign material from joint substrates that could interfere with adhesion of the joint sealant, including dust, paints (except for permanent, protective coatings tested and approved for sealant adhesion and compatibility by sealant manufacturer), old joint sealants, oil, grease, waterproofing, water repellents, water, surface dirt, and frost.
  - Clean concrete, masonry, unglazed surfaces of ceramic tile, and similar porous joint substrate surfaces by brushing, grinding, mechanical abrasion, or a combination of these methods to produce a clean, sound substrate capable of developing optimum bond with joint sealants. Remove loose particles remaining from these cleaning operations by vacuuming or blowing out joints with oil-free compressed air.
  - Clean metal, glass, porcelain enamel, glazed surfaces of ceramic tile, and other nonporous surfaces with chemical cleaners or other means that do not stain, harm substrates, or leave residues capable of interfering with adhesion of joint sealants.
  - Install backer rod or bond-breaker tape in joints greater than 1/8-inch wide, and apply sealant

in strict compliance with manufacturer's specification. The correct ratio of joint width to sealant depth is 1:1, with a maximum sealant depth of 1/2 inch. Tool sealant joints to ensure good contact with sides and produce a slightly concave surface.

- b. **Partial Joint Failure Repair:** Cut away deteriorated sealant, clean sides of joint as noted above, install backer rod (or bond-breaker tape), apply sealant, and tool to produce a slightly concave surface.

**END OF CHAPTER FIVE**

# MAINTENANCE GUIDEBOOK V ROOF AND WATERPROOFING MAINTENANCE

## GLOSSARY

**ARMA**—Asphalt Roofing Manufacturers' Association, 6288 Montrose Road, Rockville, Maryland 20852, 301/231-9050.

**AGGREGATE**—(1) crushed stone, crushed slag or water-worn gravel used for surfacing a built-up roof; (2) any granular mineral material.

**ALLIGATORING**—Cracking of the surfacing bitumen on a built-up roof, producing a pattern of cracks similar to an alligator's hide; the cracks may or may not extend through the surfacing bitumen.

**ASBESTOS**—A group of natural, fibrous, impure silicate materials.

**ASPHALT**—A dark-brown to black cementitious material in which the predominating constituents are bitumens, which occur in nature or are obtained in petroleum processing.

**BACKNAILING**—The practice of blind-nailing roofing felts to a substrate in addition to hot-mopping to prevent slippage. (See **BLIND NAILING**).

**BASE FLASHING**—(See **FLASHING**.)

**BASE PLY**—The lowermost ply of roofing material in a roof-membrane assembly.

**BASE SHEET**—Saturated or coated felt placed as the first ply in some multi-ply built-up roof membranes.

**BITUMEN**—(1) a class of amorphous, black or dark colored, (solid, semi-solid or viscous) cementitious substances, natural or manufactured, composed principally of high-molecular weight hydrocarbons, soluble in carbon disulfide, and found in asphalts, tars, pitches, and asphaltites; (2) a generic term used to denote any material composed principally of bitumen.

**BLACKBERRY**—Small bubble or blister in the flood coating of a gravel-surfaced roof membrane.

**BLISTER**—An enclosed pocket of air mixed with water or solvent vapor, trapped between impermeable layers of felt, or between the felt and substrate.

**BLOCKING**—Wood built into a roofing system above the deck and below the membrane and flashing to stiffen the deck around an opening, act as a stop for insulation, or to serve as a nailer for attachment of the membrane or flashing.

**BOND**—The adhesive and cohesive forces holding two roofing components in intimate contact.

**BUILT-UP ROOF MEMBRANE (BUR)**—A continuous, semi-flexible roof membrane assembly, consisting of plies of saturated felts, coated felts, fabrics, or mats between which alternate layers of bitumen are applied, generally surfaced with mineral aggregate, bituminous materials, or a granule-surfaced roofing sheet.

**CANT STRIP**—A beveled strip used under flashings to modify the angle at the point where the roofing or waterproofing membrane meets any vertical element.

**CAP SHEET**—A granule-surfaced coated sheet used as the top ply of a built-up roof membrane or flashing.

**CAULKING MATERIAL**—A composition of vehicle and pigment, used at ambient temperatures for filling joints, that remains plastic for an extended time after application.

**COAL TAR**—A dark-brown to black, semi-solid hydrocarbon obtained as residue from the partial evaporation or distillation of coal tar.

**CONDENSATION**—The conversion of water vapor or other gas to liquid as the temperature drops or the atmospheric pressure rises. (See DEW-POINT.)

**COPING**—The covering piece on top of a wall which protects it from water infiltration (usually sloped to shed water).

**COUNTERFLASHING**—Formed metal or elastomeric sheeting secured on or into a wall, curb, pipe, rooftop unit, or other surface, to cover and protect the upper edge of a base flashing and its fasteners.

**CRACK**—A separation or fracture occurring in a roof membrane or roof deck, generally caused by thermally induced stress or substrate movement.

**CRICKET**—A relatively small, elevated area of a roof constructed to divert water around a chimney, curb or other projection.



**DAMPPROOFING**—Treatment of surface or structure to resist the passage of water in the absence of hydrostatic pressure.

**DEAD LOADS**—Nonmoving rooftop loads, such as mechanical equipment, air conditioning units, and the roof deck itself.

**DECK**—The structural surface to which the roofing or waterproofing system (including insulation) is applied.

**DELAMINATION**—Separation of the plies in a roof membrane system or separation of laminated layers of insulation.

**DEW POINT**—The temperature at which water vapor starts to condense in cooling air at existing atmospheric pressure and vapor content.

**DRAIN**—A device that allows water to flow from a roof area. (See NRCA Construction Details.)

**EPDM**—Ethylene Propylene Diene Monomer. Single-ply rubber roof membrane, typically black, although some white membrane is sometimes used.

**EMBEDMENT**—(1) the process of pressing a felt, aggregate, fabric, mat, or panel uniformly and completely into hot bitumen or adhesive; (2) the process of pressing granules into coating in the manufacture of factory-prepared roofing.

**EXPANSION JOINT**—A structural separation between two building elements that allows free, independent movement without damage to the roofing or waterproofing system.

**FABRIC**—A woven cloth of organic or inorganic filaments, threads, or yarns.

**FACTORY MUTUAL (FM)**—An organization that classifies roof assemblies for their fire characteristics and wind-uplift resistance for insurance companies in the United States.

**FELT**—A flexible sheet manufactured by the interlocking of fibers through a combination of mechanical work, moisture, and heat. Felts are manufactured principally from vegetable fibers (organic felts), asbestos fibers (asbestos felts), or glass fibers (glass fiber felts); other fibers may be present in each type.

**FISHMOUTH**—(1) a half-cylindrical or half-conical opening formed by an edge wrinkle; (2) in shingles, a half-conical opening formed at a cut edge.

**FLASHING**—The system used to seal membrane edges at walls, expansion joints, drains, gravel stops, and other places where the membrane is interrupted or terminated. Base flashing covers the edges of the membrane. Cap flashing or counterflashing shields the upper edges of the base flashing.

**FLOOD COAT**—The top layer of bitumen into which the aggregate is embedded on an aggregate-surfaced built-up roof.

**GLASS FELT**—Glass fibers bonded into a sheet with resin and suitable for impregnation in the manufacture of bituminous waterproofing materials, roof membranes, and shingles.

**GLASS MAT**—A thin mat composed of glass fibers with or without a binder.

**GLAZE COAT**—(1) the top layer of asphalt in a smooth-surfaced built-up roof assembly; (2) a thin protective coating of bitumen applied to the lower plies or top ply of a built-up roof membrane when application of additional felts or the flood coat and aggregate surfacing are delayed.

**GRAVEL**—Coarse, granular aggregate, with pieces larger than sand grains, resulting from the natural erosion of rock.

**GRAVEL STOP**—A metal flange designed to prevent loose aggregate from being washed off the roof.

**HEADLAP**—The minimum distance, measured at 90 degrees to the eaves along the face of a shingle or felt, from the upper edge of the shingle or felt to the nearest exposed surface.

**ICE DAM**—A mass of ice formed at the transition from a warm to a cold roof surface, frequently formed by refreezing meltwater at the overhang of a steep roof, causing ice and water to back up under roofing membrane.

**INSPECTION**—Checking or testing against established standards.

**LIVE LOADS**—Weight, associated with wind, snow, ice, rain, installation of equipment, or workers on the roof, which shifts instead of bearing constantly on one location.

**LOW-SLOPE ROOFING**—A "flat" roofing system with nominal slope (1/8 inch/foot to 4 inches/foot).

**MEMBRANE**—A flexible or semi-flexible roof covering or waterproofing layer, whose primary function is the exclusion of water.

**MOPPING**—The application of hot bitumen with a mop or mechanical applicator to the substrate or to the felts of a built-up roof membrane.

**NRCA**—National Roofing Contractors Association, 10255 West Higgins Road, Suite 600, Rosemont, Illinois 708/299-9070.

**NAILINS**—Self-contained expansion anchor constructed of a zinc body and a steel pin. (Zamac Nailins by Rawl, or equal.)

**PARAPET WALL**—The part of a wall entirely above the roof, which serves to protect the edge of the roof.

**PHASED APPLICATION**—The installation of a roof or waterproofing system during two or more separate time intervals.

**PITCH POCKET**—A flanged, open-bottomed, metal container placed around columns or other roof penetrations and filled with hot bitumen or flashing cement to seal the joint. The use of pitch pockets is not recommended by NRCA.

**PLY**—A layer of felt in a built-up roof-membrane system. A four-ply membrane system has four plies of felt.

**POND**—A depression in the roof surface that retains water.

**POSITIVE DRAINAGE**—A slope in the direction of drains which, in consideration of roof loads, ensures adequate drainage of the roof area within 48 hours of rainfall.

**PREVENTIVE ROOF MAINTENANCE**—Scheduled periodic treatment procedures for preventing the development of premature roofing problems and extending the lifetime of a roof. This work includes, but is not limited to, recaulking counterflashing, painting metal surfaces, resetting flashing, cleaning roof drainage, re-slagging and re-coating roof membrane.

**PRIMER**—A thin liquid bitumen applied to a surface to improve the adhesion of subsequent applications of bitumen.

**PRMA**—Protected Roof Membrane Assembly. Also known as inverted roofing system, in which the insulation is installed above the waterproofing membrane, rather than below it.

**RAKE**—The sloped edge of a roof at the first or last rafter.

**RECEIVER**—Top portion of two-piece counterflashing.

**RE-COVER ROOF**—Installation of a new roof over the existing roof.

**REGLET**—A groove in a wall or other surface adjoining a roof surface for use in the attachment of counterflashing.

**REPLACEMENT ROOF**—Removal of all roof components down to the roof deck and installation of a new roof.

**RE-ROOFING**—The process of re-covering or replacing an existing roofing system (See RE-COVERING and REPLACEMENT.)

**ROOF**—The exterior surface and its supporting structure to protect the interior against the adverse affects of weather conditions.

**ROOF ASSEMBLY**—An assembly of interacting roof components (including the roof deck) designed to weatherproof and, normally, to insulate a building's top surface.

**ROOF REPAIR**—Restoration of a roof by correcting/replacing defective parts of products or materials in the roof system. Roof repair is a treatment following partial failure of components of the roof system. The repair may involve the replacement of broken tile or blown off shingle, patching cracked or punctured roof membranes, or other components.

**ROOF SYSTEM**—An assembly of interacting roofing materials designed to protect the building and its contents from water infiltration and damages, and to thermally insulate the top of the building envelope. A typical roof system includes all or part of the following: structural frame (beams, purlins, sub-purlins); deck, vapor retarder, insulation, waterproofing membrane, surfacing, flashing, parapet wall, roof penetrations, drainage system, and walkways.

**ROOFING**—The construction process in the construction of the roof.

**SMACNA**—Sheet Metal and Air Conditioning Contractors' National Association, Inc., 4201 Lafayette Center Drive, Chantilly, Virginia 22021 (Telephone: 703/803-2980).

**SCUPPER**—Opening in a parapet, raised gravel stop, or roof edge through which water can drain.

**SCUTTLE**—A hatch that provides access to the roof from the interior of the building.

**SEALANT**—A mixture of polymers, fillers, and pigments used to fill and seal joints where moderate movement is expected; it cures to a resilient solid.

**SHINGLING**—(1) the procedure of laying parallel felts so that one longitudinal edge of each felt overlaps and the other longitudinal edge underlaps an adjacent felt. (See PLY.) Normally, felts are shingled on a slope so that the water flows over rather than against each lap; (2) the application of shingles to a sloped roof.

**SLAG**—A hard, air-cooled aggregate that is left as a residue from blast furnaces and used as a surface aggregate.

**SLIPPAGE**—Relative lateral movement of adjacent components of a built-up membrane. It occurs mainly in roofing membranes on a slope, sometimes exposing the lower plies or even the base sheet to the weather.

**SPALL**—(1) a small fragment or chip of brick, concrete or stone; (2) the process of breaking up by chipping.

**SPLIT**—A membrane tear resulting from tensile stress.

**SPUDDING**—The process of removing the roofing aggregate and most of the bituminous top coating by scraping and chipping.

**STACK VENT**—A vertical outlet in a built-up roof system designed to relieve the pressure exerted by moisture vapor between the roof membrane and the vapor retarder or deck.

**STRIPPING OR STRIP-FLASHING**—(1) the technique of sealing a joint between metal and the built-up roof membrane with one or two plies of felt or fabric and hot-applied or cold-applied bitumen; (2) the technique of taping joints between insulation boards or deck panels.

**SUBSTRATE**—The surface upon which the roofing or waterproofing membrane is applied (the structural deck or insulation).

**SUMP**—An intentional depression around a drain.

**TEST CUT**—A sample that is cut from a roof membrane to (a) determine the weight of the average interply bitumen moppings; (b) diagnose the condition of the existing membrane (detect leaks or blisters).

**THROUGH-WALL FLASHING**—A water-resistant membrane or material assembly extending through a wall and its cavities, positioned to direct water entering the top of the wall to the exterior.

**TUCKPOINTING**—(1) troweling mortar into a joint after masonry units are laid; (2) final treatment of joints in cut stonework. Mortar or a putty-like filler is forced into the joint after the stone is set.

**UNDERWRITERS LABORATORIES (UL)**—An organization that classifies roof assemblies for their fire-resistance characteristics and wind-uplift resistance.

**VAPOR RETARDER**—A material designed to restrict the passage of water vapor through a wall or roof.

**VENT**—An opening designed to convey water vapor or other gas from inside a building or a building component to the atmosphere, thereby relieving vapor pressure.

**WATERPROOFING**—Treatment of a surface or structure to prevent the passage of water to the interior.

**WATERPROOFING SYSTEM**—The combination of individual components that work together to prevent the passage of water to the interior.

**WYTHER**—A masonry wall, one masonry unit, a minimum of two inches thick.

**END OF GLOSSARY**

# MAINTENANCE GUIDEBOOK V ROOF AND WATERPROOFING MAINTENANCE

## BIBLIOGRAPHY

- "Built-Up Roofs, Problems and Solutions." Solon, Ohio: Revere Chemical Corporation. Undated.
- "Guide To Roof Repair and Maintenance." *Roof Siding and Insulation*, Vol. 60, No. 11, November 1983, pp. 34-39.
- "Roof Surveys and Inspections." Englewood, California: The Roofing Industry Education Institute. Undated.
- Sheet Metal and Air Conditioning Contractors Association. *Architectural Sheet Metal Manual*, 4th Edition, 1987.
- Bailey, Shahin and Brotherson. *Membrane and Flashing Condition Indexes For Built-Up Roofs, Volume II: Inspection and Distress Manual*. US Army Construction Engineering Research Laboratory, September 1987.
- Building Officials & Code Administrators International, Inc. The BOCA Basic Property Maintenance Code, 2nd Edition. Danville, Illinois: Interstate Printers and Publishers, Inc., 1981. (PM-302, PM-506)
- Carlson, Jim. "Torch Tricks for Repair of Modifieds," *Professional Roofing* (National Roofing Contractors Association), July 1992, pp. 34-39.
- Laaly, Heshmat O. *The Science and Technology of Traditional and Modern Roofing Systems*, 1st Edition. Laaly Scientific Publishing, 1992.
- NRCA/ARMA Manual of Roof Maintenance and Repair*. National Roofing Contractors Association and Asphalt Roofing Manufacturers Association, 1988.
- NRCA Roofing and Waterproofing Manual*. National Roofing Contractors Association, 3rd Edition, 1989.
- SPRI/NRCA Manual of Roof Inspection, Maintenance, and Emergency Repair for Existing Single-Ply Roofing Systems*. Wellesley Hills, Massachusetts: Single-Ply Roofing Institute, and National Roofing Contractors Association, April 1992.
- "Roofing Systems Management Program." USAFESA. (Draft Copy).

**MAINTENANCE GUIDEBOOK V  
ROOF AND WATERPROOFING MAINTENANCE  
APPENDIX A - HISTORICAL ROOFING RECORD**



HISTORICAL ROOFING RECORD  
(Prepare One Record for Each Roof)

BASIC ROOF INFORMATION

Name of HA: \_\_\_\_\_  
Development Name/No. \_\_\_\_\_ / \_\_\_\_\_

Building Name/No. \_\_\_\_\_ / \_\_\_\_\_  
Address: \_\_\_\_\_

Date Constructed: \_\_\_\_\_

Use: \_\_\_\_\_ (Permanent / Temporary)

Roof Membrane Installation: Original / Recover / Replacement  
If Recover Roof, Note Original Membrane Type: \_\_\_\_\_  
\_\_\_\_\_

Date of Existing Roof Completion: \_\_\_\_\_

Roofing Contractor:

\_\_\_\_\_  
Name  
\_\_\_\_\_  
Address  
\_\_\_\_\_  
Telephone Number

Contractor Warranty: (Yes / No) Expiration Date: \_\_\_\_\_

Membrane Manufacturer:

\_\_\_\_\_  
Name  
\_\_\_\_\_  
Address  
\_\_\_\_\_  
Telephone Number

Manufacturer Warranty: (Yes / No) Expiration Date: \_\_\_\_\_

BUILDING SYSTEM INFORMATION

Structural Frame System (Wood / Steel / Concrete / Masonry)  
Exterior Wall System (Siding\_\_\_\_\_/ Brick / CMU / Concrete)

Structural Roof Deck: (Wood / Concrete Slab / Concrete Plank /  
Gypsum / Steel / Other\_\_\_\_\_)

Ventilation: (Yes / No) Type: \_\_\_\_\_

Roof Slope (Dead Level / Low Slope / Steep Slope) \_\_\_\_\_  
(Inches/Foot; Rise/Run)

Area of Roof: Squares \_\_\_\_\_ (One square equals 100 SQ. FT.)

ROOF SYSTEM INFORMATION

Roof Surfacing: \_\_\_\_\_  
Type of Roof Membrane: \_\_\_\_\_

Attachment: (Mechanically Fastened / Mopped / Ballasted)

Insulation: (Yes / No) Type: \_\_\_\_\_  
Location: (Conventional / PRMA / Ceiling)  
R-Value: \_\_\_\_ Thickness \_\_\_\_\_ No. of Layers \_\_\_\_\_  
Attachment: (Mechanically Fastened/Mopped/Ballasted)

Vapor retarder: (Yes / No) Type: \_\_\_\_\_

Flashings:

Base flashings: (Metal / Composition / Other\_\_\_\_\_)  
Material(s) \_\_\_\_\_ Cant strip: (Yes / No)

Counter or cap flashings: (Yes / No)  
Type: (One Piece / Two Piece / Surface Mounted)  
Material: \_\_\_\_\_

Reglet Joint: (Mortar/Sealant)

Through Wall: (Yes / No) Material: \_\_\_\_\_

DRAINAGE SYSTEM INFORMATION

Roof drains: \_\_\_\_\_

Scuppers: \_\_\_\_\_

Gutters: \_\_\_\_\_

Downspouts: \_\_\_\_\_

Boots on Downspouts: \_\_\_\_\_ Type: \_\_\_\_\_

MAINTENANCE AND REPAIR HISTORY

Previous Maintenance: (Describe briefly with dates.)

Roof membrane: \_\_\_\_\_  
\_\_\_\_\_

Flashings: \_\_\_\_\_  
\_\_\_\_\_

Previous Maintenance: (Describe briefly with dates.)

Roof membrane: \_\_\_\_\_  
\_\_\_\_\_

Flashings: \_\_\_\_\_  
\_\_\_\_\_

Previous Repairs (Describe briefly with dates.)

Roof membrane: \_\_\_\_\_  
\_\_\_\_\_

Flashings: \_\_\_\_\_  
\_\_\_\_\_

Previous Repairs (Describe briefly with dates.)

Roof membrane: \_\_\_\_\_  
\_\_\_\_\_

Flashings: \_\_\_\_\_  
\_\_\_\_\_

Roofing Contractor:

(completing repairs)

\_\_\_\_\_  
Name

\_\_\_\_\_  
Address

\_\_\_\_\_  
Telephone Number

Contractor Warranty: (Yes / No) Expiration Date: \_\_\_\_\_

**END OF HISTORICAL ROOFING RECORD**

**MAINTENANCE GUIDEBOOK V  
ROOF AND WATERPROOFING MAINTENANCE  
APPENDIX B - ROOF INSPECTION FORM**

ROOF INSPECTION FORM

Name of HA: \_\_\_\_\_ Date \_\_\_\_\_  
 Name of Development: \_\_\_\_\_  
 Development No: \_\_\_\_\_  
 Building \_\_\_\_\_ Building No. \_\_\_\_\_  
 Address \_\_\_\_\_ Inspector(s) \_\_\_\_\_  
 Number of Floors: \_\_\_\_\_  
 Roof Area (Squares): \_\_\_\_\_ (1 Square = 100 SQ. FT.)  
 Type of Deck: \_\_\_\_\_ Roof Type: (Low Slope, Steep Slope)

Roofing System Description: (Brief) \_\_\_\_\_

Installation Date: \_\_\_\_\_  
 Installation Contractor: \_\_\_\_\_  
 Warranty Expiration Date: \_\_\_\_\_

**FIRST PHASE - INTERIOR INSPECTION**

Reported Leaks: (Yes/No) Locations: \_\_\_\_\_

WALLS	Location	COMMENT/DIAGRAM
Cracking _____	_____	
Moisture Stains _____	_____	Wet/Dry
Deterioration _____	_____	
Physical Damage _____	_____	
Potential Leak _____	_____	
Source(s) _____	_____	
Other _____	_____	

CEILING	Location	
Cracking _____	_____	
Moisture Stains _____	_____	Wet/Dry
Deterioration _____	_____	
Physical Damage _____	_____	
Other _____	_____	
Potential Leak _____	_____	
Source(s) _____	_____	

Pipe/Drain Insulation (Yes/No) Condition: \_\_\_\_\_

STRUCTURAL DECK (UNDERSIDE)	Location	
Cracking _____	_____	
Moisture Stains _____	_____	Wet/Dry
Deterioration _____	_____	
Physical Damage _____	_____	
Other _____	_____	
Potential Leak _____	_____	
Source(s) _____	_____	
Securement to Supports: _____	_____	
Sagging/Deflection: _____	_____	
Expansion Joints: _____	_____	

Insulation Fasteners Visible: (Yes/No) Deterioration: \_\_\_\_\_

**SECOND PHASE - EXTERIOR INSPECTION**

<u>WALLS</u>	<u>Location</u>	<u>COMMENT/DIAGRAM</u>
Settlement Cracks (Yes/No)	_____	_____
Expansion/Contraction (Yes/No)	_____	_____
Moisture Stains (Yes/No)	_____	_____
Deterioration (Yes/No)	_____	_____
Physical Damage (Yes/No)	_____	_____
Other (Yes/No)	_____	_____
Gutter Damage (Yes/No)	_____	_____
Downspout Damage (Yes/No)	_____	_____
Surface Drainage (Good/Fair/Poor)	_____	_____

<u>ROOF</u>	<u>Location</u>
General Appearance (Good/Fair/Poor)	_____
Debris (Yes/No)	_____
Drainage (Ponding/Stains)	_____
Physical Damage (Yes/No)	_____

**THIRD PHASE - ROOF INSPECTION**

Locate Areas of Leaks and Interior Damage Per Interior Inspection

Flashing Condition

Base Flashing

- Height
- Base/Membrane Joint
- Open Laps/Seams
- Attachment
  - Top Edge
  - To Wall
  - At Cant
- Deterioration
- Ridging/Wrinkling
- Other

Counterflashing

- Attachment
  - Fasteners
- Rusting/Deterioration
- Caulking (Surf. Mtd)
- Mortar Joint (Reglet)
- Other

Drainage

- Obstructions/Depressions
- Gutters & Leaders
  - Debris
  - Attachment
- Roof Drains
  - Debris
  - Flashing
  - Clamping Rings
  - Drain Domes
- Roof Drains
  - Ponding
- Scuppers
  - Debris
  - Ponding
  - Stripping

Roof Edge/Fascia

- Metal Deterioration (Yes/No) Extent: \_\_\_\_\_
- Felt Deterioration (Yes/No)
- Loose/Missing (Yes/No) Extent: \_\_\_\_\_
- Splits at Joints (Yes/No) Extent: \_\_\_\_\_
- Other

Coping

- Open Joints (Yes/No) (Mortar/Sealant) Extent: \_\_\_\_\_
- Loose/Missing (Yes/No) Extent: \_\_\_\_\_
- Metal Deterioration: (Yes/No) Extent: \_\_\_\_\_
- Masonry/Concrete Deterioration (Yes/No) Extent: \_\_\_\_\_
- Fasteners:
  - Deterioration
  - Securement
  - Other

Membrane

- Check Observations of type with Historical Data File Patches:
  - Surface Deterioration (Yes/No) Extent: \_\_\_\_\_
  - Edge/Seals (Good/Fair/Poor) Extent: \_\_\_\_\_
- Bare Spots (Yes/No)
- Alligatoring
- Slippage
- Ultra-violet Degradation
- Splitting
- Ridging
- Fishmouths
- Seams
- Walkways
- Coating
- Fasteners
- Securement

Expansion Joints

Open Joints  
Punctures/Splits  
Securement  
Rusting  
Fasteners

Roof Penetrations

New Equipment Locations  
Abandoned Equipment Locations  
Equipment Base Flashing  
Open Laps/Seams  
Punctures  
Attachment  
Other  
Equipment Housing  
Counterflashing  
Open Seams  
Rusting  
Physical Damage  
Caulking  
Drainage  
Other  
Equipment Operation  
Discharge of Contaminants  
Excess Traffic Wear  
Other  
Equipment Supports  
Blocking drainage  
Adequate Height  
Physical Damage

Pitch Pans

Stripping  
Filler  
Penetration

Vent Pipes

Stripping  
Cap/Top Seal

Walls/Parapets

Mortar Joints  
Spalling  
Movement Cracks  
Other



**MAINTENANCE GUIDEBOOK V  
ROOF AND WATERPROOFING MAINTENANCE  
APPENDIX C - ADDITIONAL RESOURCES**

## RESOURCES FOR ADDITIONAL INFORMATION

National Roofing Contractors Association (NRCA)  
10255 West Higgins Road Phone 708/299-9070  
Rosemont, Illinois 60018

### Publications of Special Interest:

NRCA Roofing and Waterproofing Manual  
NRCA/ARMA "Manual of Roof Maintenance and Repair"  
NRCA/SPRI "Manual of Roof Inspection, Maintenance, and  
Emergency Repair for Existing Single-Ply Roofing Systems"  
"Insist on a Roofing Professional"  
"Practical Guidelines For Controlling Water Damage"

Single Ply Roofing Institute (SPRI)  
104 Wilmot Road, Suite 201 Phone 708/940-8800  
Deerfield, Illinois 60015

Asphalt Roofing Manufacturers Association (ARMA)  
6288 Montrose Road Phone 301/231-9050  
Rockville, Maryland 20852

American Society for Testing Materials (ASTM)  
1916 Race Street Phone 215/977-9679  
Philadelphia, Pennsylvania 19103

Vermont Structural Slate Co, Inc.  
Fair Haven, Vermont 05743 Phone 802/265-4933

Publication of Special Interest: "Slate Roofs" (1926  
version)

Roofing Industry Educational Institute  
6851 South Holly Circle, Suite 250  
Englewood, Colorado 80112

Sheet Metal and Air Conditioning Contractors National Association  
(SMACNA)  
4201 Lafayette Center Drive Phone 703/803-2980  
Chantilly, Virginia 22021

Publication of Special Interest: "Architectural Sheet Metal  
Manual"