

Installation, Operation and Maintenance Manual

Series PWSPSE

Water Softener Systems

PURE WATER

Important

Please read the entire manual before proceeding with the installation and startup. Your failure to follow any attached instructions or operating parameters may lead to the product's failure.

Save manual for future reference

Refer to enclosed for operating parameters to ensure proper use with your water supply.



PWSPSE

Table of Contents

Pages

Important Safety Information – Read All	2
Softener Anatomy	3
Specifications	4
Setup	4
Installation	5-6
Control Start-up Procedures	7
Service	7
Softener Operation	8
Troubleshooting	9
Water Softener System Parts List	10
Limited Warranty	12

Note: Do not use with water that is microbiologically unsafe or of unknown quality without adequate disinfection before or after the system.



Important Safety Information – Read All



Caution: Read and follow the information in this manual to minimize the risk of electric shock or personal injury.

Important: If you are unsure about installing your Watts water softener, contact a Watts representative or consult a professional plumber.

Important: This system must be installed in compliance with applicable state, province and local codes, law, and regulations.

READ Instructions Before Using

- Before beginning installation, read these instructions completely. Then obtain all the materials and tools needed for installation.

NOTE: Failure to install the system correctly voids the warranty.

- Perform installation according to state, province and local plumbing codes.

Use only lead-free solder and flux for sweat-solder connections, as required by state, province and federal codes.

- Handle all components of the system with care. Do not drop, drag or turn components upside down.
- Be sure the floor under the water softening system is clean and level.
- The system uses 24 volt-60Hz electrical power. Always use the transformer supplied.

Plug transformer into an indoor 120 VAC, grounded outlet.

Properly ground the system to conform with all codes and ordinances.

- Install the system in a protected area. Be sure electric outlet and transformer do not come in contact with water. See Where to Install the Softener, in the installation section of the manual.

Do not attempt to treat water over 110°F (43°C) with the system. Always connect the system to the main water supply pipe before water heater.

Do not expose the system to freezing temperatures. Water freezing in the system causes equipment damage.

Do not install in direct sunlight. Ultraviolet rays from the sun may cause damage.

- Minimum inlet water pressure is 20 psi. Maximum inlet water pressure is 125 psi. Use a pressure reducing valve if necessary.
- Sodium used in the water softening process should be considered as part of your overall dietary salt intake. Contact physician if you are on a low sodium diet.
- Use clean water softening salts only, at least 99.5% pure. Failure to use the correct salt may create a health hazard or maintenance problems.

Use nugget, pellet or coarse solar salts.

Do not use rock, block, granulated or ice cream making salts.

- Always keep the salt lid in place unless servicing the unit or replenishing salt.



Caution:

- Do not use with water that is microbiologically unsafe or of unknown quality.
- Test the water periodically to verify that the system is performing satisfactorily.
- Discard small parts remaining after the installation.

Softener Anatomy

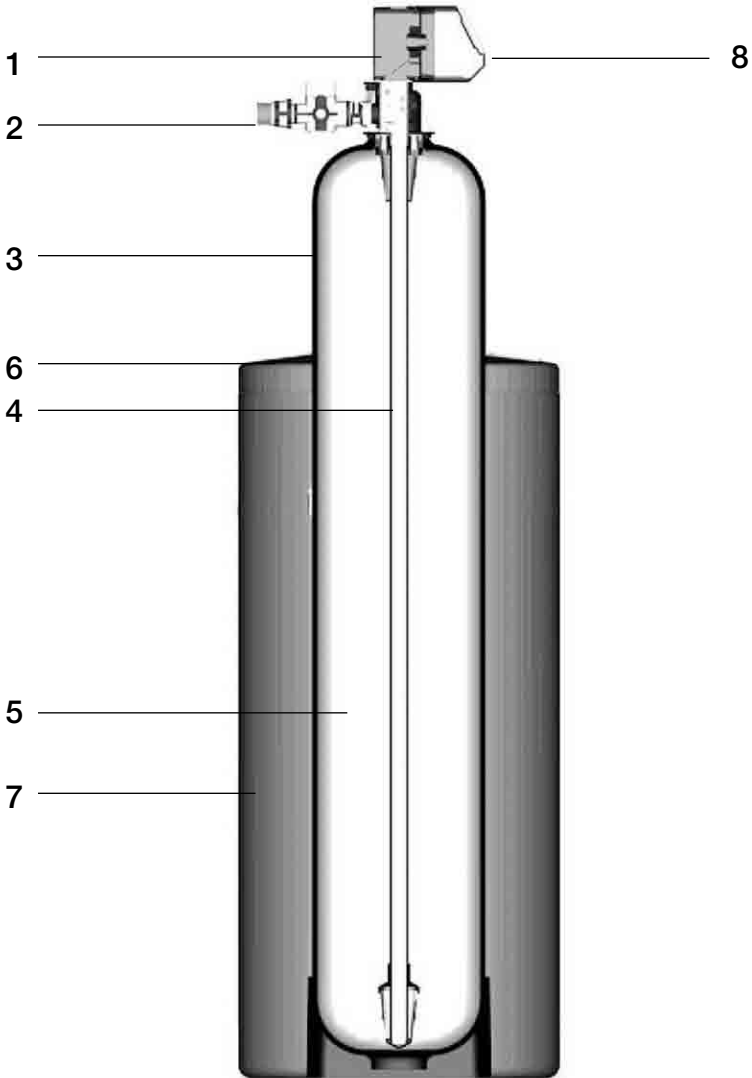

ITEM #	DESCRIPTION
1	Valve
2	Bypass
3	Resin Tank
4	Distributor
5	Resin
6	Salt Tank Lid
7	Salt Tank
8	Faceplate/Controls
Not Shown	Brine Valve Assembly

Specifications

Feed water

! Do not use this system on water that is microbiologically unsafe or of unknown quality without adequate disinfection before or after the system !

Minimum inlet pressure: 20 psig

Maximum operating pressure: 125 psig

Minimum water temperature: 34°F (1°C)

Maximum water temperature: 110°F (43°C)

Power

Voltage: 120VAC

Frequency: 60Hz

Power consumption: 7 Watts Maximum

Installation

Location: Indoors (Protect from direct sunlight)

Minimum ambient temperature: 34°F

Maximum ambient temperature: 122°F

Brine Tank Salt Capacity

32K, 45K & 60K = 300 lbs.

90K & 120K = 400 lbs.

Drain Flow Rates

32K - (1.0 ft³ resin) – rated drain flow during regeneration – 2.0 gpm

45K - (1.5 ft³ resin) – rated drain flow during regeneration – 2.4 gpm

60K - (2.0 ft³ resin) – rated drain flow during regeneration – 3.5 gpm

90K - (3.0 ft³ resin) – rated drain flow during regeneration – 4.0 gpm

120K - (4.0 ft³ resin) – rated drain flow during regeneration – 7.0 gpm

Shipping Weights - approximate

30K – 112 lbs

45K – 130 lbs

60K – 190 lbs

90K – 265 lbs

Setup

Unpack and check the system components for damage or missing parts.

Where to Install the Softener

Consider the following points when determining where to install the water softener:

- Place the system as close as possible to a sewer drain.
- Do not install the softener where it would block access to the water heater, or access to the main water shutoff, water meter, or electrical panels.
- Keep outside faucets on hard water to save soft water and salt.
- Install the softener in a place where water damage is least likely to occur if a leak develops.
- A 120VAC electrical outlet is needed to plug in the transformer. If the outlet is remote (up to 100 feet), use 18 gauge wire to connect.
- Always connect the system to the main water supply pipe before the water heater.
- Install the system where it will not be subject to temperatures outside of the limits stated in the Specification section or to direct sunlight.

Determine Hardness Setting

Municipal Water

It is recommended that you call your local water company to determine your water hardness in grains per gallon and iron in mg/l (or ppm).

Well Water

It is recommended that you have your water tested professionally for accurate hardness and iron content.

Installation

1. Turn off gas or electric supply to the water heater.
2. Turn off the water supply to pipes to be cut and drain the house water pipes.
3. Open both hot and cold faucets.
4. Move the softener assembly into installation position.
 - Be sure the installation surface is level and smooth.
5. Plumb IN and OUT connections to and from softener.
 - Be sure the incoming hard water supply is directed to the INLET port of the valve.
 - The valve body of the control is marked with arrows indicating the proper flow direction.
 - Connections are illustrated below.

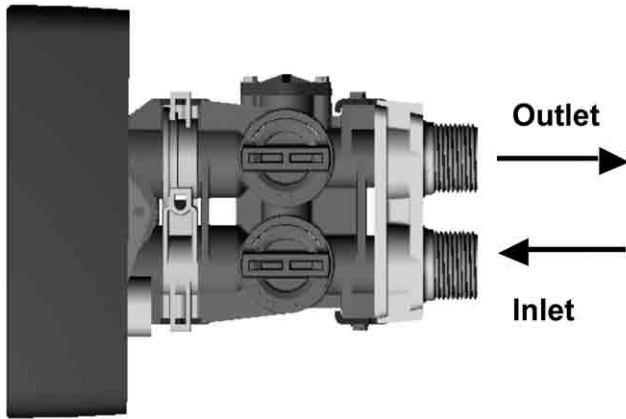

Figure 2

CAUTION: If making a soldered copper installation, do all sweat soldering before connecting pipes to the bypass valve. Torch heat will damage plastic parts.

CAUTION: When turning threaded pipe fittings onto plastic fittings, use care not to cross-thread.

CAUTION: Use Teflon tape on all external pipe threads. Do not use pipe joint compound.

CAUTION: Support inlet and outlet plumbing in some manner (use pipe hangers) to keep the weight off of the valve fittings.

Perform steps 6-9 to install flexible drain tube.

Skip to step 10 to install rigid drain pipe.

6. Cut the 10' piece of 3/8" OD black tubing in half. One section will be used as the valve drain line. The remaining section will be used as an overflow tube (Step 11).
7. Locate the barbed drain fitting on the back of the valve.
8. Connect and route the valve drain line.
 - Use the provided tubing to attach to the valve drain fitting. Use the included clamp to keep water pressure from blowing the tubing off of the fitting.
9. Locate the other end of the drain tubing at a suitable drain.
 - Tie or wire the tube in place at the drain point. Also provide an air gap of at least 1 1/2" between the end of the hose and the drain point.

Use Step 10 to install rigid drain pipe.

10. To install a rigid drain pipe instead of tubing:
 - Remove the barbed fitting from the drain port.
 - Plumb 1/2" rigid pipe from female drain port to the drain location. Leave an air gap of at least 1 1/2" between the end of the drain plumbing and the drain point.
11. Take the other half of the cut tubing and attach it to the overflow adapter elbow located on the side of the brine tank. Locate the other end of the hose at the drain point, leaving an air gap as shown in Figure 3.

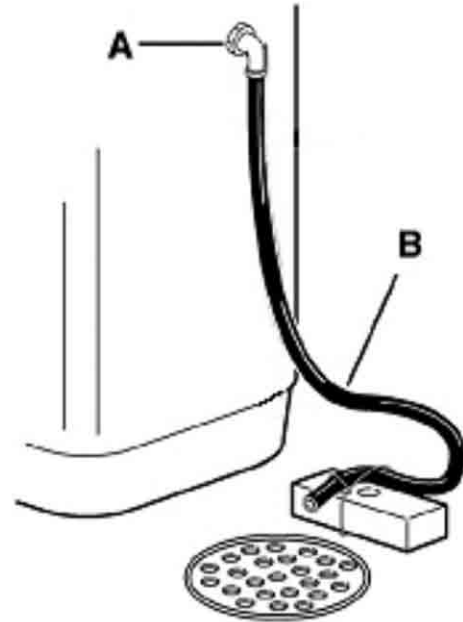

A-Overflow Elbow Fitting
B-Overflow Tubing

Figure 3

12. Connect brine line from the safety valve in the brine tank to the brine port on the valve using the 3/8" tubing provided. Be sure to use the brass nut, brass insert, plastic ferrule, and stainless steel screen (included in the small parts bag) when attaching the brine line to the valve.
13. Place bypass valve in "bypass" position as shown in figure 4.



Figure 4

Installation continued

14. Fully open two (2) cold (soft) water faucets near the water softener.
15. Fully open the house main water shutoff valve. Observe a steady flow from both faucets.
16. Slowly, turn bypass valve back to the "service" position. Keep soft water faucets open.

NOTE: If the water appears cloudy or has a slight yellow color, allow it to run for several more minutes until it runs clear.

17. After the air is purged and the water runs clear, open a HOT water faucet until all air is expelled, then close.
18. Close all water faucets.
19. Check plumbing work for leaks and fix immediately if any are found.
20. Connect electrical power by plugging the power cord into a (120 VAC) outlet.

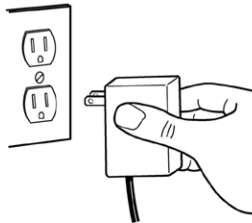

21. Set the time of day. Press and hold either the Up or Down buttons until the programming icon replaces the service icon and the parameter display reads TD. Adjust the displayed time with the Up and Down buttons. When the desired time is set, press the Extra Cycle button to resume normal operation. The unit will also return to normal operation after 5 seconds if no buttons are pressed.

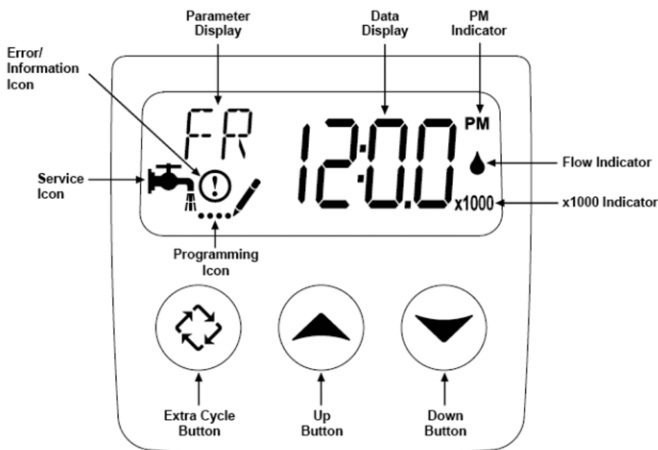

Figure 5

22. Although the material used in the manufacturing of this water softener will not contaminate your water supply, the softener could become contaminated during shipment and installation. The media inside the resin tank may also have become disturbed during shipping. The following procedure will help re-position the media, sanitize, flush and condition your water softener:

- a) Remove the brine tank cover and add salt to the tank. Use only nugget, pellet, or coarse solar salt designed for water softener use with a purity of 99.5% or higher.
- b) Add three gallons of water to the brine tank for 32K, 45K, & 60K systems, and add 5 gallons of water for 90K & 120K systems.
- c) Remove the brine well cover. Pour 1-1/2 ounces of common household bleach into the brine well and replace the cover (see figure 6).

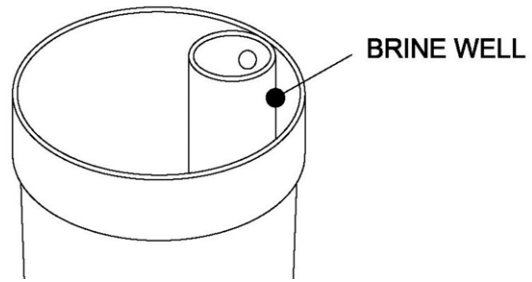

Figure 6

- d) Turn ON the gas or electric supply to the water heater.
- e) Manually initiate a regeneration by pressing and holding the "Extra Cycle" button on the front of the controller for approximately 5 seconds (see figure 5). Release the "Extra Cycle" when you hear the valve start to cycle. The controller will automatically step the valve through the proper cycles. This will take approximately two hours.

23. It will be necessary to enter the controller master programming function (see separate ProFlo SXT service manual included with system) and program the hardness setting to match the compensated feed water hardness of the water supply. The compensated hardness is:

Feed water hardness in grains per gallon times the compensation factor plus 2 grains for each ppm of iron rounded up to the next whole number.

FEED WATER HARDNESS	COMPENSATION FACTOR
1 – 20 grains	1.1
21 – 40 grains	1.2
41 – 70 grains	1.3
71 – 100 grains	1.4
> 100 grains	1.5

Example: Feed water hardness = 17 grains, iron = 0.5 ppm

The compensated hardness is $17 \times 1.1 + 1 = 19.7$ so the hardness setting would be 20 grains.

Note: This step can be performed at the same time as step 21 above if desired.

Control Start-up Procedures

Control start-up, flushing/conditioning and programming procedures may be found in the control service manual included with your system.

Control Service Manual: ProFlo SXT Downflow Brining Service Manual

Softener Operation

As water enters the softener, it passes over a resin bed in the mineral tank. The resin consists of tiny beads of plastic called styrene. These beads attract and hold sodium ions and exchange the sodium for hardness ions when encountered. Over time, the resin becomes saturated with hardness ions and no longer removes hardness materials. The softener goes into a "regeneration" to flush hardness materials to the drain and refresh the resin with sodium. Regeneration is typically programmed to take place in the middle of the night when little or no water is in use.

Regeneration consists of four cycles:

1. Brine Draw / Slow Rinse Position

Brine Draw: The process in which brine is drawn out of the brine cabinet and passed through the resin in a downward direction. This rinses the resin and large amounts of sodium ions replace the hardness ions accumulated during service. **Slow Rinse:** After brine is completely transferred from the brine cabinet into the resin tank the brine valve closes. Water replaces any remaining brine from the resin, flushing hardness ions removed from the resin to drain.

2. Backwash Position

Backwash is a rapid upward flow of water that loosens the resin bed and flushes iron particles, dirt and sediments filtered in the bed out to the drain.

3. Fast Rinse Position

Fast Rinse is a fast flow of water down through the resin tank that follows a Backwash. This flushes all remaining brine from the tank and packs the resin bed for softening efficiency.

4. Brine Fill

Brine is water saturated with large amounts of salt (sodium chloride). During brine fill, water flows into the salt storage area after each regeneration and dissolves salt. During the regeneration process, hardness ions on the resin beads are replaced or exchanged for sodium ions from the brine solution.

5. Service

When the softener is In Service water is flowing through the system and removing hardness minerals from your water.

Service

Cleaning Iron Out of the Water Softening System

The system is designed to remove minerals like calcium and magnesium from household water. Periodic resin bed cleaning is recommended if your iron rating is high. Clean the bed at least every six months, or more if iron appears in the soft water between cleanings. Contact the system installer for this service.

Checking for a Salt Bridge

A hard crust or "Salt Bridge" can form in the lower half of the salt storage tank. This can be deceiving because the tank will appear to have plenty of salt, but underneath, salt has hardened and when the system regenerates, water cannot quite reach this level to be made into brine (water and salt).

Breaking a Salt Bridge

Take a wooden broom handle and carefully push it down into the salt, working it up and down. If the tool strikes a hard object (be sure it's not the bottom or sides of the tank), it's probably a salt bridge. Carefully break the bridge with the broom handle. Do not pound on the walls of the tank.

NOTE: Salt bridges are typically caused by high humidity or using the wrong kind of salt. In humid areas it is best to fill with less salt, more often. Use only nugget, pellet or coarse solar salt with a purity of 99.5% or higher. DO NOT use rock, block, granulated, and ice cream-making salts, or salt with iron-removing additives.

Service continued

Cleaning the Injector and Screen

- 1) Turn off water supply to conditioner:
 - a) If the conditioner installation has a “three valve” by-pass system, first open the valve in the bypass line, then close the valves at the conditioner inlet and outlet.
 - b) If the conditioner has an integral by-pass valve, put it in the by-pass position.
 - c) If there is only a shutoff valve near the conditioner inlet, close it.
- 2) Relieve water pressure in the conditioner by stepping the control into the backwash position momentarily. Return the control to the service position.
- 3) Unplug electrical cord from outlet.
- 4) Remove the two injector cap mounting screws.
- 5) To replace injector and screen.
 - a) Pull the screen and injector throat/nozzle assembly out of the valve body.
 - b) Insert a new injector throat/nozzle assembly, be sure they are sealed tightly. Install a new screen.
 - c) Apply silicone lubricant to new injector cap seal.
- 6) Replace injector cap with two mounting screws.
- 7) Tighten screws.
- 8) Return by-pass or inlet valving to normal service position. Water pressure should now be applied to the conditioner, and any by-pass line shutoff.
- 9) Check for leaks at all seal areas. Check the drain seal with the control in the backwash position.
- 10) Plug electrical cord into outlet.
- 11) Set time of day and cycle the control valve manually to assure proper function. Make sure control valve is returned to the service position.
- 12) Make sure there is enough salt in the brine tank.
- 13) Start regeneration cycle manually if water is hard.

Troubleshooting

PROBLEM	CAUSE	SOLUTION
1. Softener Fails To Regenerate.	A. Electrical Service to Unit has been Interrupted.	A. Assure Permanent Electrical Service (Check Fuse, Plug, Pull Chain or Switch).
	B. Timer Programming Bad (Improper Programming).	B. Check Programming and Reset as Needed.
2. Softener Delivers Hard Water.	A. By-Pass Valve is Open.	A. Close By-Pass Valve.
	B. No Salt in Brine Tank.	B. Add Salt to Brine Tank and Maintain Salt Level Above Water Level.
	C. Injectors or Screen Plugged.	C. Clean or Replace Injectors and Screen.
	D. Insufficient Water Flowing into Brine Tank.	D. Check Brine Tank Fill Time and Clean Brine Line flow if Plugged.
	E. Hot Water Tank Hardness.	E. Repeated Flushing of the Hot Water Tank is Required.
	F. Flow Meter Jammed.	F. Check flow indicator light for flow. Remove obstruction from flow meter.
	G. Flow Meter Cable Disconnected or Not Plugged into Meter.	G. Check Meter Cable Connection to Timer and Meter.
	H. Improper Programming.	H. Reprogram the control to the Proper Regeneration Type, Inlet Water Hardness, Capacity or Flow Meter Size.
	I. Plugged brine line or air check.	I. Remove and clean any sediment from the brine tank and brine valve assembly.
	J. Salt bridge has formed.	J. Refer to Breaking a Salt Bridge section in manual
	K. No water in brine tank.	K. Ensure safety float is not stuck.
	L. Unit is plumbed backwards.	L. Check that the unit is plumbed correctly.
	M. Water hardness has increased or is set incorrectly.	M. Retest hardness and change settings
N. Water pressure is too low.	N. Line pressure must be at least 20psi.	
3. Unit Uses Too Much Salt.	A. Improper Salt Setting.	A. Check Salt Usage and Salt Setting.
	B. Excessive Water in Brine Tank.	B. See Problem No. 7.
	C. Improper Programming.	C. Check Programming and Reset as Needed.
4. Loss of Water Pressure.	A. Iron Buildup in Line to Water Conditioner.	A. Clean Line to Water Conditioner.
	B. Iron Buildup in Water Conditioner.	B. Clean Control and Add Resin Cleaner to Resin Bed. Increase Frequency of Regeneration.
5. Loss of Resin Through Drain Line.	A. Air in Water System.	A. Assure that Well System has Proper Air Eliminator control Check for Dry Well Condition.
	B. Drain Line Flow Control is too large.	B. Ensure Drain Line Flow Control is Sized Correctly.
6. Iron in Conditioned Water.	A. Fouled Resin Bed.	A. Check Backwash, Brine Draw and Brine Tank Fill. Increase Frequency of Regeneration. Increase Backwash Time.
	B. Iron Content Exceeds Recommended Parameters.	B. Add Iron Removal from Filter or System.
7. Excessive Water in Brine Tank.	A. Plugged Drain Line Flow Control.	A. Clean Flow Control.
	B. Brine Valve Failure.	B. Clean Brine Valve.
	C. Improper Programming.	C. Check Programming and Reset as Needed.
8. Salt Water in Service Line.	A. Plugged Injector System.	A. Clean Injector and Replace Screen.
	B. Improper Programming.	B. Check Programming and Reset as Needed.
	C. Foreign Material in Brine Valve.	C. Clean or Replace Brine Valve.
	D. Foreign Material in Brine Line Flow Control.	D. Clean Brine Line Flow Control.
	E. Low Water Pressure.	E. Raise Water Pressure.
9. Softener Fails to Draw Brine.	A. Drain Line Flow Control is Plugged.	A. Clean Drain Line Flow Control.
	B. Injector is Plugged.	B. Clean or Replace Injectors.
	C. Improper Programming.	C. Check Programming and Reset as Needed.
	D. Line Pressure is too Low.	D. Increase Line Pressure (Line Pressure must be at Least 20 PSI at all Times.)
10. Drain Flows Continuously.	A. Foreign Material in Control.	A. Remove Piston Assembly and Inspect Bore, Remove Foreign Material & Check Control in Various
11. Loss of capacity.	A. Increased raw water hardness	A. Reset unit to the new capacity.
	B. Brine concentration and/or quantity.	B. Keep brine tank full of salt at all times. Clean it yearly. Salt may be bridged. If using a salt grid plate ensure refill water is over it.
	C. Resin fouling. future fouling.	C. Call the dealer, find out how to confirm it, clean the resin and prevent
	D. Poor distribution, Channeling (uneven bed surface).	D. Call the dealer. Check distributors and backwash flow.

Parts List

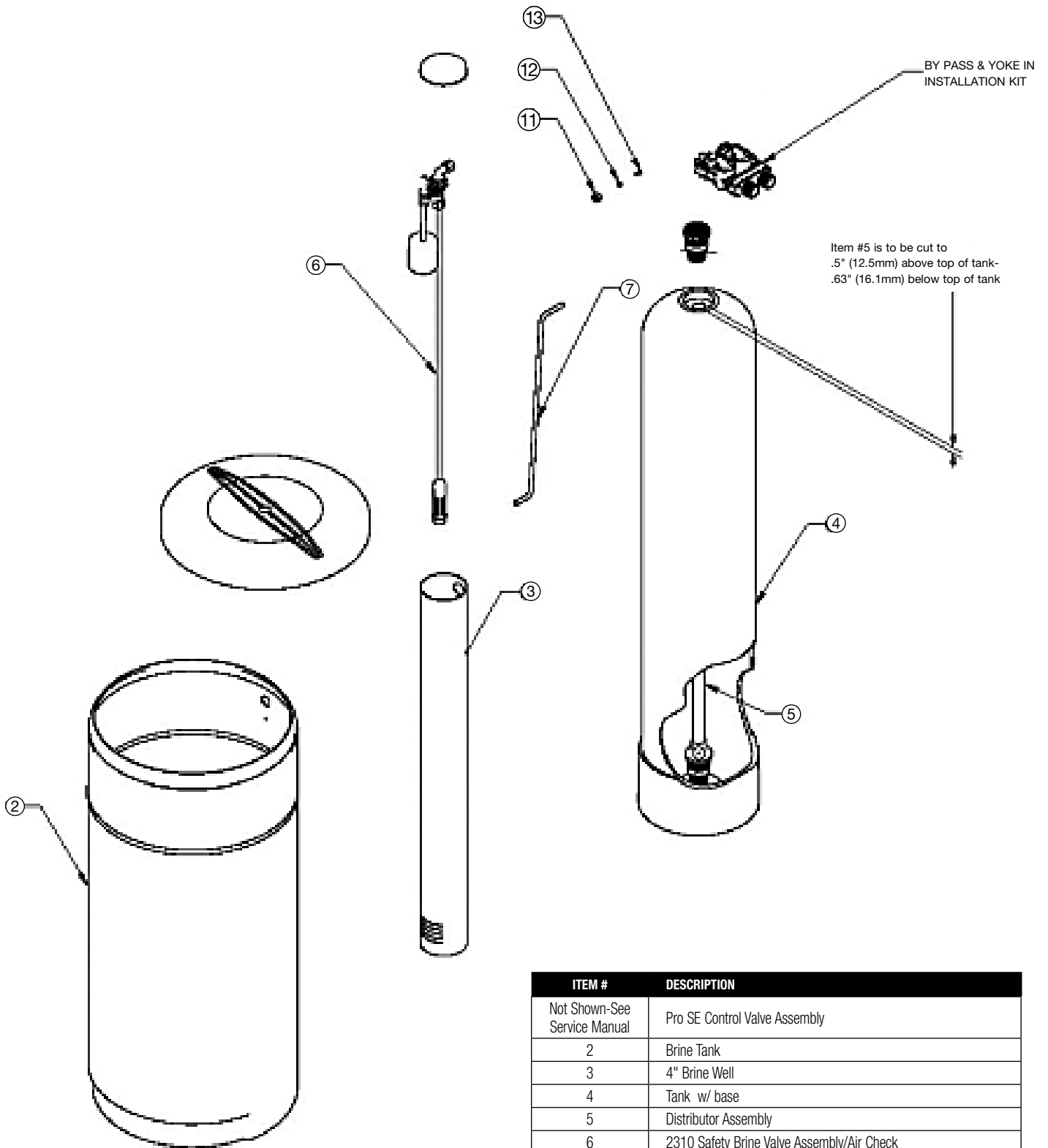

ITEM #	DESCRIPTION
Not Shown-See Service Manual	Pro SE Control Valve Assembly
2	Brine Tank
3	4" Brine Well
4	Tank w/ base
5	Distributor Assembly
6	2310 Safety Brine Valve Assembly/Air Check
7	3/8" Brine Line Tube
11	Fitting, Tube, .375 Nut, Brass
12	3/8" Delrin Ferrule
13	Brass Insert, 3/8" tube

CALIFORNIA PROPOSITION 65 WARNING

WARNING: This product contains chemicals known to the State of California to cause cancer and birth defects or other reproductive harm. (California law requires this warning to be given to customers in the State of California.)

For more information: www.watts.com/prop65

LIMITED WARRANTY: Certain Watts Pure Water products come with a limited warranty from Watts Regulator Co. Other products may have no warranty or are covered by the original manufacturer's warranty only. For specific product warranty information, please visit www.watts.com or the published literature that comes with your product. Any remedies stated in such warranties are exclusive and are the only remedies for breach of warranty. **EXCEPT FOR THE APPLICABLE PRODUCT WARRANTY, IF ANY, WATTS MAKES NO OTHER WARRANTIES, EXPRESS OR IMPLIED. TO THE FULLEST EXTENT PERMITTED BY APPLICABLE LAW, WATTS HEREBY SPECIFICALLY DISCLAIMS ALL OTHER WARRANTIES, EXPRESS OR IMPLIED, INCLUDING BUT NOT LIMITED TO THE IMPLIED WARRANTIES OF MERCHANTABILITY AND FITNESS FOR A PARTICULAR PURPOSE, AND IN NO EVENT SHALL WATTS BE LIABLE, IN CONTRACT, TORT, STRICT LIABILITY OR UNDER ANY OTHER LEGAL THEORY, FOR INCIDENTAL, INDIRECT, SPECIAL OR CONSEQUENTIAL DAMAGES, INCLUDING, WITHOUT LIMITATION, LOST PROFITS OR PROPERTY DAMAGE, REGARDLESS OF WHETHER IT WAS INFORMED ABOUT THE POSSIBILITY OF SUCH DAMAGES.**



A Watts Water Technologies Company

USA: Tel. (800) 224-1299 • www.watts.com

Canada: Tel. (888) 208-8927 • www.watts.ca