

CLICK ANYWHERE on THIS PAGE to RETURN TO AQUA SYSTEMS WATER SOFTENERS at [InspectApedia.com](http://InspectApedia.com)



**IMPORTANT:** Fill in pertinent information on *page 3* for future reference.

# Model 9000/9100/9500

---

## *Table of Contents*

Job Specifications Sheet	3
General and Commercial Installation Checklist	4
General and Commercial Installation Checklist	6
Regeneration Cycle Program Setting Procedure	9
Time Brine Refill and Meter Setting Procedure	10
<b>ET</b> Timer Installation And Start-Up Procedures	12
<b>ET</b> Timer Control Start-Up Procedure	14
<b>ET</b> Timer Control Operation	15
<b>SE</b> Timer Control Start-Up Procedures	18
<b>ET</b> and <b>SE</b> Timer Assemblies	21
<b>9000/9100/9500</b> Electro Mechanical Timer Assembly	22
<b>9000/9100/9500</b> Power Head	24
<b>9000/9100/9500</b> Power Head	25
<b>9000</b> Control Valve Assembly	26
<b>9100</b> Control Valve Assembly	28
<b>9500</b> Control Valve Assembly	30
<b>9500</b> Brine Valve Systems ( <b>1600</b> and <b>1700</b> Series)	31
<b>9000/9100/9500</b> Second Tank Assemblies	32
<b>9000/9100/9500</b> Meter Assemblies	34
<b>9000/9100</b> Bypass Valve	36
<b>2310</b> Safety Brine Valve	37
<b>9500, 2350</b> Safety Brine Valve	38
<b>2300</b> Safety Brine Valve	39
Water Conditioner Flow Diagrams	40
Troubleshooting	44
Mechanical Timer Valve Wiring	46
<b>ET</b> Timer Valve Wiring	47
<b>SE</b> Timer Valve Wiring	48
<b>9000</b> Control Dimensions	49
<b>9100</b> Control Dimensions	50
<b>9500</b> Control Dimensions	51
Meter Flow Data	52
Injector Flow Data	54

# Model 9000/9100/9500

---

## Job Specifications Sheet

Job Number \_\_\_\_\_

Model Number \_\_\_\_\_

Water Test \_\_\_\_\_

Capacity Of Unit \_\_\_\_\_ Max. \_\_\_\_\_ Per Regeneration

Brine Tank Size \_\_\_\_\_

Salt Setting Per Regeneration \_\_\_\_\_

### Control Valve Specifications

1. Type of Timer
  - A. 82 minute available regeneration time, 1/15 RPM
  - B. 164 minute available regeneration time, 1/30 RPM
2. Type of Meter

#### Mechanical Valves (gallon settings)

<i>Meter</i>	<i>Standard Range</i>	<i>Extended Range</i>
3/4"	125–2,125	625–10,625
1"	310–5,270	1,150–26,350
1-1/2"	625–10,625	3,125–53,125

#### Electrical Timers (minutes per cycle)

<i>Meter</i>	<i>ET</i> (0–999.9 minutes per cycle)	<i>SE</i> (0–99 minutes per cycle)
3/4"	9,999,999	9,999
1"	9,999,999	9,999
1-1/2"	9,999,999	—

3. Timer Gallon Setting \_\_\_\_\_ gal.
4. Regeneration Program Setting
  - A. Backwash \_\_\_\_\_ min.
  - B. Brine and Slow Rinse \_\_\_\_\_ min.
  - C. Rapid Rinse \_\_\_\_\_ min.
  - D. Brine Tank Refill \_\_\_\_\_ min.
5. Drain Line Flow Control \_\_\_\_\_ gpm
6. Brine Refill Rate \_\_\_\_\_ gpm
7. Injector Size \_\_\_\_\_

# Model 9000/9100/9500

---

## *General and Commercial Installation Checklist*

### **Water Pressure**

A minimum of 25 lbs of water pressure is required for regeneration valve to operate effectively.

### **Electrical Facilities**

An uninterrupted alternating current (A/C) supply is required. Make sure:

- Voltage supply is compatible with unit before installation.
- Current supply is always hot and cannot be turned off with another switch.

### **Existing Plumbing**

Condition of existing plumbing should be free from lime and iron buildup. Replace piping that has heavy lime and/or iron build-up. If piping is clogged with iron, install a separate iron filter unit ahead of the water softener.

### **Location of Softener and Drain**

Locate the softener close to a clean working drain and connect according to local plumbing codes.

### **Bypass Valves**

Always provide for the installation of a bypass valve if unit is not equipped with one.

	<p><b>CAUTION</b></p> <ul style="list-style-type: none"><li>• <b>Do not exceed water pressure of 125 psi.</b></li><li>• <b>Do not exceed 110°F water temperature.</b></li><li>• <b>Do not subject unit to freezing conditions.</b></li></ul>
-----------------------------------------------------------------------------------	----------------------------------------------------------------------------------------------------------------------------------------------------------------------------------------------------------------------------------------------

# Model 9000/9100/9500

## Equipment Configuration

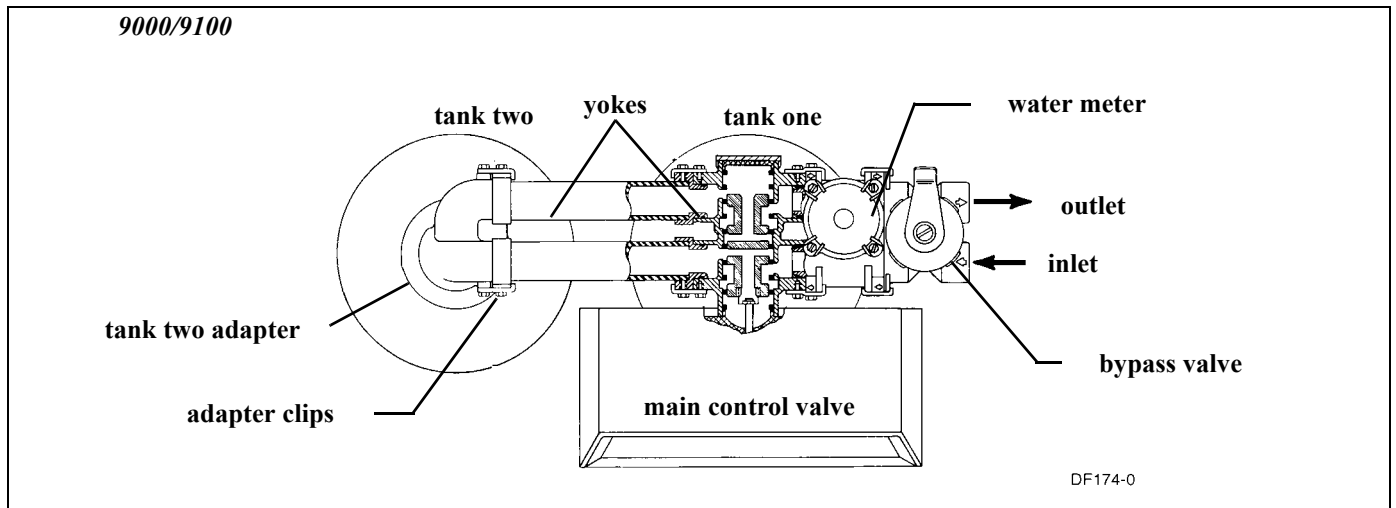

Figure 1: 9000/9100

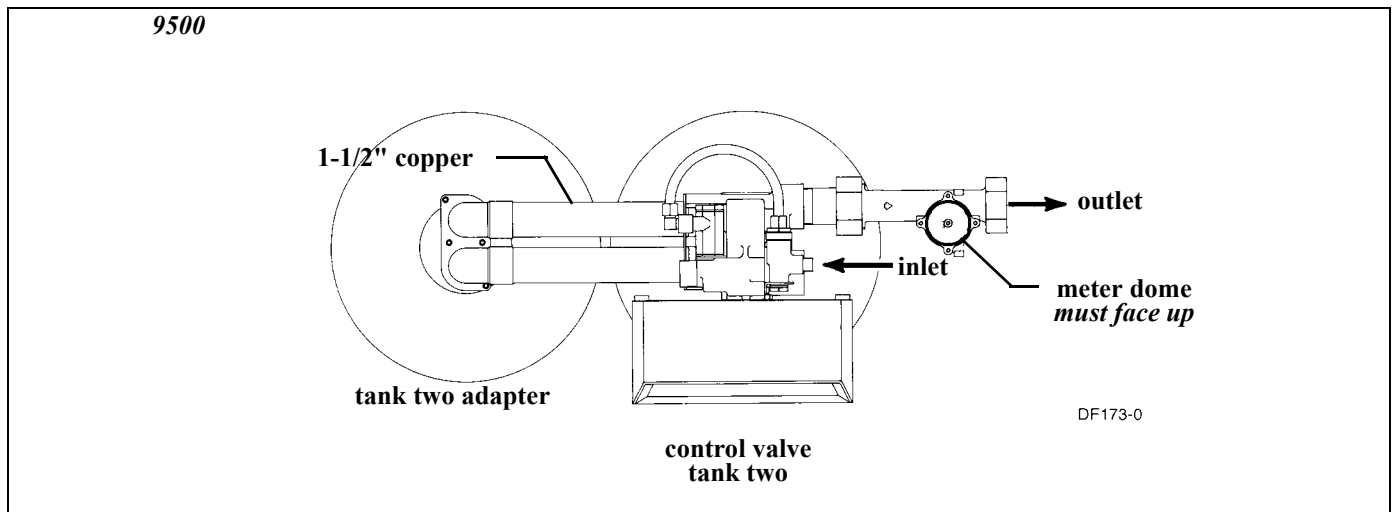

Figure 2: 9500

# Model 9000/9100/9500

---

## *General and Commercial Installation Checklist*

1. Place the softener tank where you want to install the unit.  
**NOTE:** Be sure the tank is level and on a firm base.
2. During cold weather it is recommended that the installer warm the valve to room temperature before operating.
3. Perform all plumbing according to local plumbing codes.
  - Use a 1/2" minimum pipe size for the drain.
  - Use a 3/4" drain line for backwash flow rates that exceed 7 gpm or length that exceeds 20' (6 m).
4. Both tanks must be the same height and diameter and filled with equal amounts of media.
5. The distributor tube must be flush with the top of each tank. Cut if necessary. Use only non-aerosol silicone lubricant.
6. Lubricate the distributor o-ring seal and tank o-ring seal. Place the main control valve on one tank and the tank adapter on the second tank.  
**NOTE:** If required, solder copper tubing for tank interconnection before assembling on the main control valve and tank adapter. Maintain a minimum of 1" distance between tanks on final assembly.
7. Solder joints near the drain must be done before connecting the Drain Line Flow Control fitting (DLFC). Leave at least 6" (152 mm) between the DLFC and solder joints when soldering pipes that are connected on the DLFC. Failure to do this could cause interior damage to DLFC.
8. Use only **Teflon** tape on the drain fitting.
9. Be sure the floor under the salt storage tank is clean and level.
10. Place approximately 1" (25 mm) of water above the grid plate. If a grid is not utilized, fill to the top of the air check in the salt tank. Do not add salt to the brine tank at this time.
11. On units with a bypass, place in **Bypass** position.
  - Turn on the main water supply.
  - Open a cold soft water tap nearby and let water run a few minutes or until the system is free of foreign material (usually solder) resulting from the installation. Close the water tap when water runs clean.
12. Place the bypass **In Service** position and let water flow into the mineral tank. When water flow stops, slowly open a cold water tap nearby and let water run until air is purged from the unit. Then close tap.

### **Electrical**

13. Make all electrical connections according to codes. Plug the valve into an approved power source. **Do not insert meter cable** into the meter yet.
14. Tank one has control valve and tank two has adapter. See [Figure 1, page 5](#) or [Figure 2, page 5](#).
15. Look on the right side of the control valve, it has indicators showing which position the control valve is in during **Regeneration** and which tank is **In Service**.
  - [Figure 3, page 7](#) shows the valve **In Service** position with tank one supplying conditioned water and tank two on standby.**NOTE:** Make sure the meter cable is not inserted in the meter dome. Swing the timer out to expose the program wheel (to swing timer out) grab onto the lower right corner of timer face and pull outward. See [Figure 5, page 8](#).

# Model 9000/9100/9500

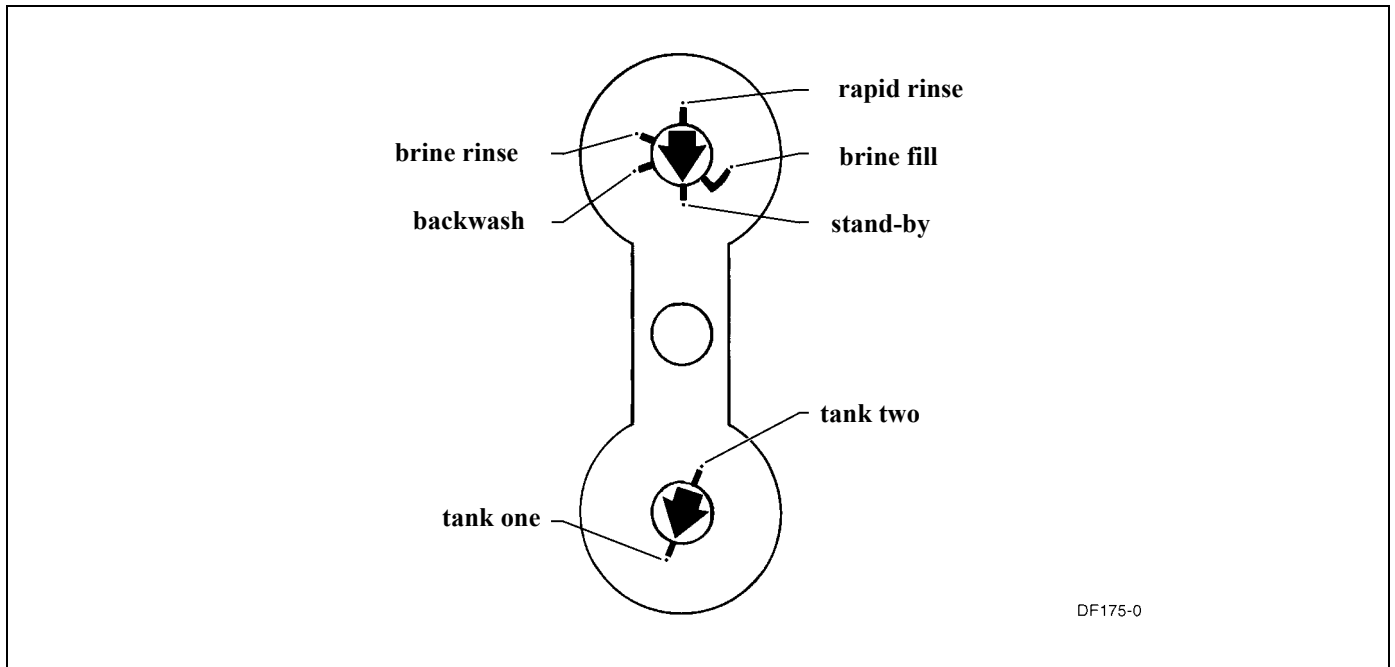

Figure 3: Control Valve Position Indicators

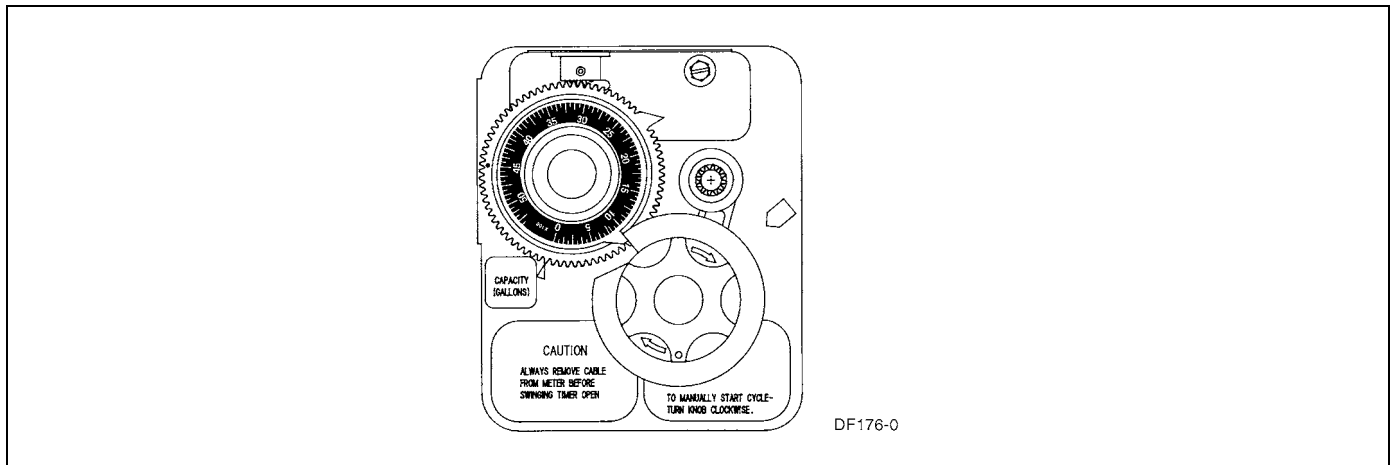

Figure 4: Timer

16. Cycle timer into backwash position. Turn manual knob so that the micro switch rides on the first set of pins.
  - In this position the tanks switch (lower piston) and the control valve moves to the backwash position (upper piston).
  - Wait until the positioning of upper and lower pistons stops before advancing the timer further. *If advanced too fast* the control will not *home* into the **In Service** position (it will not advance to any other position). To correct this, rotate the manual knob back to **In Service** and start again into backwash.

**NOTE:** Once valve positions itself into the backwash cycle, the homing circuit locks in.
17. With all the air backwashed, slowly cycle the timer to the brine position; rapid rinse; and brine tank refill. Wait for the control drive motor to position itself in each cycle and stop, before advancing on to the next position.
18. Once back in the **In Service** position, cycle the control valve again into the backwash position. The tanks switch again, and air head backwashes out of the other tank. Cycle the control back to the **In Service** position. Leave the timer in the open position. **DO NOT** insert meter cable yet.

# Model 9000/9100/9500

---

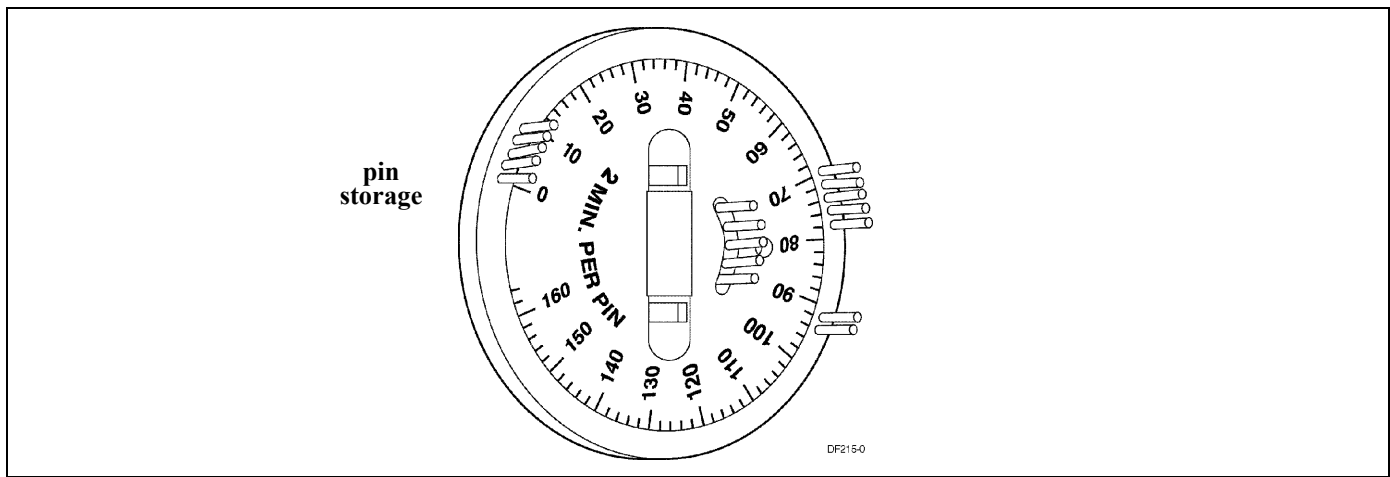

Figure 5: Program Wheel

**NOTE:** Two motors are available:

1/15 RPM has 82 minute **Regeneration Time**.

1/30 RPM has 164 minute **Regeneration Time**. See [Figure 5](#).



# Model 9000/9100/9500

---

## *Regeneration Cycle Program Setting Procedure*

### Setting the Regeneration Cycle Program

The **Regeneration** cycle program on the water conditioner is preset at the factory. However, portions of the cycle or program time may be lengthened or shortened for local conditions or system design.

1. Expose cycle program wheel by grasping timer in lower right hand corner and pulling. This releases snap retainer and swings timer to the left

*NOTE:* Meter cable *must* be removed from meter dome before opening timer.

2. Remove the program wheel by grasping program wheel and squeezing protruding lugs towards center. Lift program wheel off timer.

— Switch arms may require movement to facilitate removal.

3. Return timer to closed position by engaging snap retainer in back plate.

— Make certain all electrical wires locate above snap retainer post.

### Changing Length of the Backwash Time

The program wheel in *Figure 5* is **In Service** position. Looking at the numbered side of the program wheel, the group of pins starting at zero determines the length of time the unit backwashes.

*Example:* If there are six pins in this section, the time of backwash is 12 minutes (2 minutes per pin). To change the length of backwash time, add or remove pins as required.

— The number of pins multiplied by two equals minutes of backwash.

### Changing Length of Brine and Rinse Time

The group of holes between the last pin in the backwash section and the second group of pins determines the length of time that a unit will brine and rinse (2 minutes per hole).

To change the length of brine and rinse time, add or remove pins in the rapid rinse group of pins to increase or decrease the number of holes in the brine and rinse section.

— The number of holes multiplied by two equals minutes of brine and rinse.

### Changing Length Of Rapid Rinse

The second group of pins on the program wheel determines the length of time the water conditioner rapid rinses (2 minutes per pin). To change the length of rapid rinse time, add or remove pins at the higher numbered end of this section as required.

— The number of pins multiplied by two equals minutes of rapid rinse.

*NOTE:* Program wheels with 0–82 minute cycle times, use one minute per pin or hole to set **Regeneration** times. The layout of pins and holes on the program wheel follow the same procedure as on this page.

### Changing Length of Brine Tank Refill Time

The second group of holes on the program wheel determines the length of time the water conditioner refills the brine tank (2 minutes per hole).

To change the length of refill time, move the two pins at the end of the second group of holes as required.

The **Regeneration** cycle is complete when the two pin set at end of the brine tank refill section trips the outer micro-switch. The program wheel, however, continues to rotate until the inner micro-switch drops into the notch on the program wheel.

# Model 9000/9100/9500

---

## *Time Brine Refill and Meter Setting Procedure*

### Programming

1. The control valve is set at the factory for backwash; brine and slow rinse; rapid rinse and brine tank fill times. Change any of these times by repositioning the pins and holes or adding more pins.

**NOTE:** Two speed timer motors are available

1/15 RPM has 82 minute **Regeneration Time** and each pin or hole equals one minute.

1/30 RPM has 164 minute **Regeneration Time** and each pin or hole equals two minutes.

2. The control valve has a separate brine tank fill cycle.

— Calculate the desired salt setting using the brine line flow control rate of refill (in gpm) multiplied by the timer setting. Then, using one gallon of fresh water dissolving approximately 3 lbs salt, calculate the refill time.

**Example:** A desired 30 lbs salt setting:

The unit has a 1.0 gpm refill rate so a 10 gallon fill is required.

$$10 \text{ gallons} \times 3 \text{ lbs/gals} = 30 \text{ lbs salt}$$

Set the timer refill section at 10 minutes.

$$10 \text{ minutes} \times 1.0 \text{ gpm} = 10 \text{ gallon fill}$$

**NOTE:** There must always be two pins at the end of a refill time to stop the fill cycle.

With the **Regeneration** times set, place timer back to its original position, making sure the lower right hand corner snaps back into the backplate and the meter cable slides through the backplate and does not bind.

3. Setting the gallon wheel.

Knowing the amount of resin in each tank and the salt setting per **Regeneration**, calculate the gallons available, using the following capacities as a guide:

$$\frac{(\text{capacity per ft}^3 \times \text{ft}^3 \text{ of resin per tank})}{\text{compensated hardness of H}_2\text{O}} = \text{gallons available}$$

**NOTE:** Based on tank size:

More resin increases capacity, less resin decreases capacity.

More salt increases capacity, less salt decreases capacity.

**Example:**

tank diameter	=	16"
compensated hardness	=	35 grains per gal (tested sample)
ft <sup>3</sup> resin (based on flow rate)	=	4
lbs of salt	=	8
capacity per ft <sup>3</sup>	=	24,000

$$\frac{(24,000 \times 4 \text{ ft}^3 \text{ of resin per tank})}{35 \text{ grains}} = 2740 \text{ gallons available before regeneration}$$

**DO NOT SET THIS FIGURE - GO TO STEP 4**

- Because the control valve regenerates with soft water from the other tank, subtract the water used for **Regeneration**. Take each **Regeneration** cycle and calculate the water used.

# Model 9000/9100/9500

---

**Example:** Unit is set for a 16" diameter tank with 4 ft<sup>3</sup> of resin and salted at 8 lbs. per ft<sup>3</sup>, 7 gpm backwash, #3 injector, 1.0 gpm brine refill, and 60 psi and timer set for *10 min. backwash, 60 min. brine and rinse, 10 min. rapid rinse, 10 min. brine tank fill.*

<i>Backwash</i>	10 minutes x 7.0 gpm =	70.0 gallons
<i>Brine and Rinse</i>	60 minutes x 1.0 gpm =	60.0 gallons
<i>Rapid Rinse</i>	10 minutes x 7.0 gpm =	70.0 gallons
<i>Brine Tank Fill</i>	10 minutes x 1.0 gpm =	10.0 gallons
	Total Regeneration Water =	210.0 gallons

With the 2740 gallons available calculated in Step 3, subtract the **Regeneration** water used from the total water available.

$$\begin{array}{r} 2740 \text{ gallons available} \\ - 210 \text{ gallons used} \\ \hline 2530 \text{ gallons} \end{array}$$

(in **Regeneration**, Step 4)

- Set meter wheel at approximately 2530 gallons. Lift the inner dial of the meter program wheel so that you can rotate it freely. Position the white dot opposite the 2530 gallon setting.

**NOTE:** There is a slight delay between the time the meter zeros out and the cycle starts. Units using the:

1/15 RPM motor, 82 minute **Regeneration Time** has a *9 minute delay*

1/30 RPM motor, 180 minute **Regeneration Time** has an *18 minute delay*.

This delay period is not critical on residential equipment. However, take this factor into consideration for commercial applications by subtracting continuous flows for 9 minutes or 18 minutes from water available.

- Insert meter cable into meter.
- Check bypass.
- Plug in unit.

# Model 9000/9100/9500

## ET Timer Installation And Start-Up Procedures

1. In Normal Operation the **Time Of Day** and, if flow meter equipped, the **Volume Remaining** displays appear alternately. Set the **Time Of Day** display. Press the **Up** or **Down** set button to display the correct time.

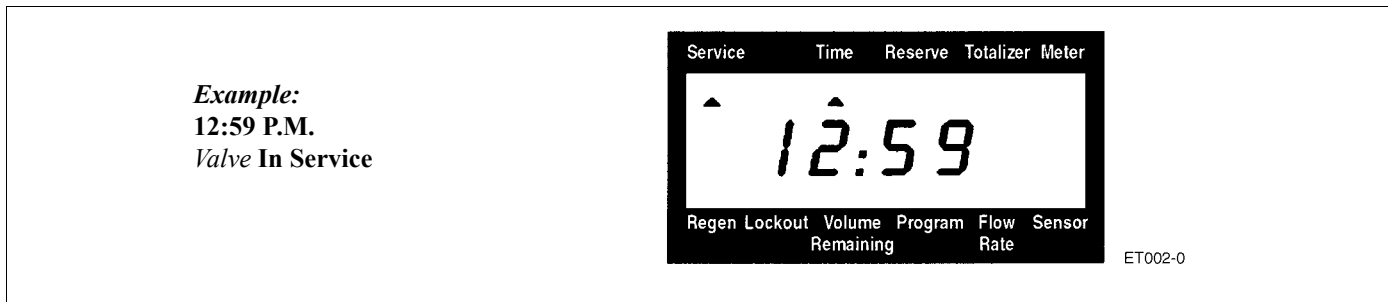

Figure 6

2. *Flow Meter Equipped Valves Only:* The Volume Remaining Display displays the volume of water in gallons (including any reserve capacity) remaining prior to **Regeneration**. When there is no water usage the Meter arrow should not appear or not change. Open a soft water tap. The Meter arrow begins flashing at a rate that varies with flow rate. Close the tap after 3–5 gallons of water flow.

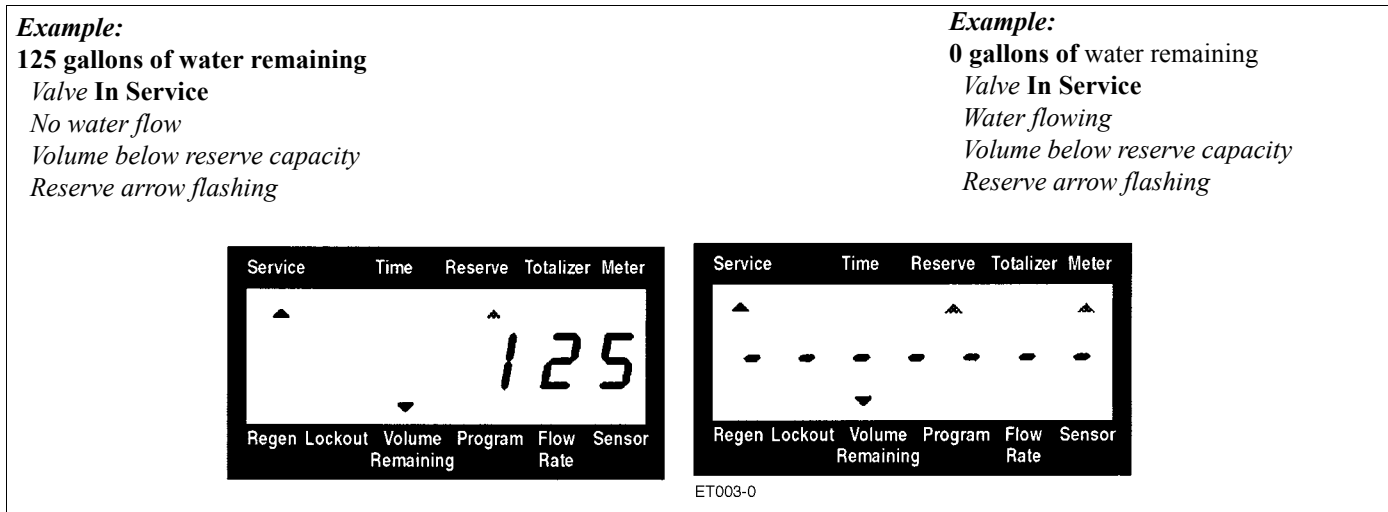

Figure 7

3. Manually initiate a **Regeneration** cycle and allow water to run to drain for 3 to 4 minutes. Press and release the **Extra Cycle** button. With Immediate Regeneration timers the control goes into **Regeneration** immediately. With Delayed Regeneration timers the **In Service** arrow flashes immediately and a **Regeneration** occurs at the preset **Regeneration Time**. Press and hold the **Extra Cycle** button for 5 seconds. The control goes into **Regeneration** immediately.
4. Manually step the valve through a **Regeneration** cycle, checking valve operation in each step. During **Regeneration** the control displays the **Regeneration** step number to which the valve is advancing or has reached and the time remaining in that step.

# Model 9000/9100/9500

**Example:**

**Valve advancing to Regeneration Step #1**  
#1 flashing  
Regeneration arrow on

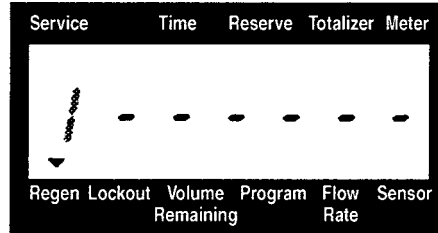

ET065-0

Figure 8

— When the first cycle step is reached, a red LED turns on indicating the current **Regeneration** cycle step.

**Example:**

**Regeneration Step #1 reached**  
10.0 minutes remain in Step #1  
Regeneration arrow on

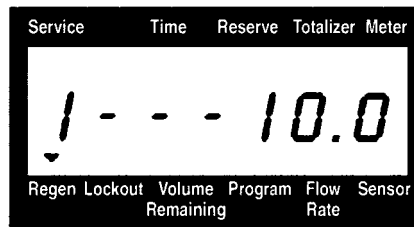

ET067-0

Figure 9

- Press the **Extra Cycle** button during a **Regeneration** step to immediately advance the valve to the next **Regeneration** step position.
  - Press the **Up** or **Down** set buttons during a **Regeneration** step to adjust the time remaining in the current **Regeneration** step. Programmed **Regeneration** step times are not changed.
  - Once all **Regeneration** cycle steps are complete, the valve returns to **In Service** and resumes normal operation.
5. Manually step the valve to the Brine Draw position (see Step #15) and allow the valve to draw water from the brine tank until it stops.  
**\*NOTE:** The air check checks at approximately the midpoint of the screened intake area.
  6. Manually step the valve to the Brine Refill position and allow the valve to return to **In Service** automatically.
  7. Make sure the brine refill time (salt dosage) is set as recommended by the manufacturer.
  8. With the valve **In Service**, check that there is about 1" of water above the grid in the brine tank, if one is used.
  9. Fill the brine tank with salt.

**NOTE:** It is recommended a **9V Alkaline Battery** be installed at all times for proper valve operation. The Low Battery LED turns on when the battery needs to be replaced.

# Model 9000/9100/9500

## ET Timer Control Start-Up Procedure

### Display ET

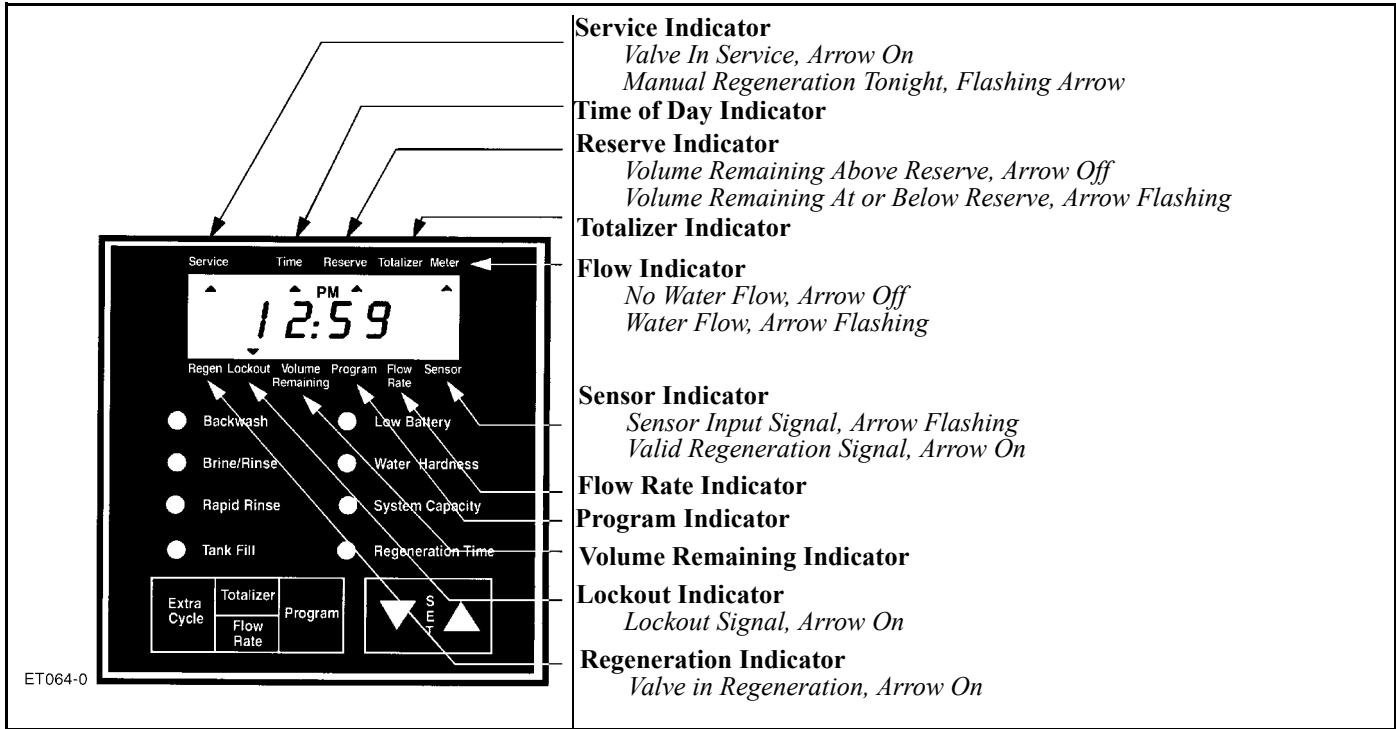
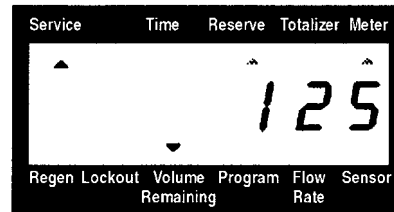

Figure 10: ET Timer Display

In Normal operation the **Time Of Day** display alternates with the **Volume Remaining** display. The meter arrow flashes in direct relation to the water flow rate through the unit. As treated water is used, the **Volume Remaining** display counts down from a maximum value to the calculated reserve capacity. The Reserve arrow flashes when the reserve capacity is being used. At the preset **Regeneration Time**, a **Regeneration** cycle initiates.

**Example:**

**125 gallons of water remaining**  
*Valve In Service*  
*No water flow*  
*Volume is below reserve capacity*



**Example:**

**0 gallons of water remaining**  
*Valve In Service*  
*Water flowing*  
*Meter arrow flashing*  
*Volume is below reserve capacity*

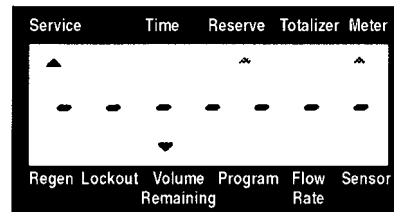

ET007-0

Figure 11

# Model 9000/9100/9500

## ET Timer Control Operation

### Timeclock Regeneration Valves

When the number days since the last **Regeneration** reaches the preset number of days, a **Regeneration** cycles initiates at the preset **Regeneration Time**.

### Flow Meter Equipped Immediate Regeneration Valves

The **Time Of Day** display alternates with the **Volume Remaining** display. The Meter arrow flashes in direct relation to the water flow rate through the unit. As treated water is used, the **Volume Remaining** display counts down from a maximum value to zero and initiates a **Regeneration** cycle.

**Example:**  
525 gallons of water remaining  
Valve In Service  
Water flowing  
Meter arrow flashing

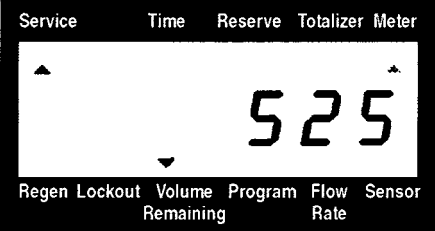

The digital display shows '525' in the center. Above the display are labels: Service, Time, Reserve, Totalizer, Meter. Below the display are labels: Regen Lockout, Volume Remaining, Program, Flow Rate, Sensor. A small upward arrow is on the left and a small downward arrow is on the right.

ET008-0

Figure 12

### Sensor Immediate Regeneration Valves

When the control receives a valid sensor input signal, a **Regeneration** cycle initiates. The Sensor Input arrow flashes until the signal is determined to be valid.

### Sensor Delayed Regeneration Valves

When the control receives a valid sensor input signal, a **Regeneration** cycle initiates at the preset **Regeneration Time**. The Sensor Input arrow flashes until the signal is determined to be valid. The Reserve arrow flashes when the reserve capacity is being used.

**Example:**  
12:58 A.M. with invalid sensor signal  
Valve In Service  
Sensor arrow flashing



The digital display shows '12:58 PM'. Above the display are labels: Service, Time, Reserve, Totalizer, Meter. Below the display are labels: Regen Lockout, Volume Remaining, Program, Flow Rate, Sensor. A small upward arrow is on the left and a small downward arrow is on the right.

**Example:**  
12:59 A.M. with valid sensor signal  
Valve In Service  
Sensor arrow on  
Reserve arrow flashing  
Delayed regeneration



The digital display shows '12:59 PM'. Above the display are labels: Service, Time, Reserve, Totalizer, Meter. Below the display are labels: Regen Lockout, Volume Remaining, Program, Flow Rate, Sensor. A small upward arrow is on the left and a small downward arrow is on the right.

ET009-0

Figure 13

### Lockout Input Operation

The lockout arrow turns on whenever the control sends a lockout signal. Any requests for **Regeneration** are delayed until this signal is removed. **Regeneration** then proceeds normally.

# Model 9000/9100/9500

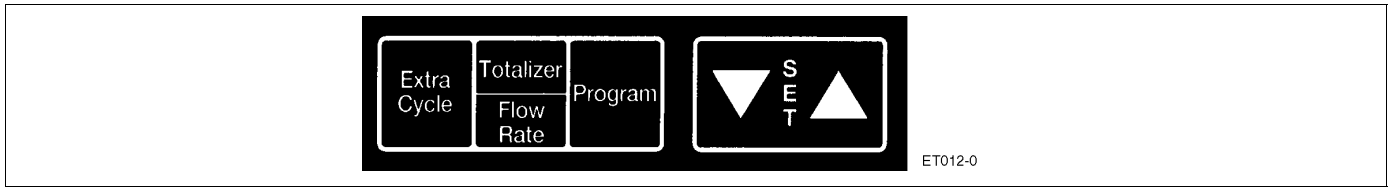

Figure 14

## Start an Extra Cycle

Press the **Extra Cycle** button to start an **Extra Regeneration** tonight. Press and hold the **Extra Cycle** button for 5 seconds to start an **Extra Cycle** immediately.

## Totalizer/Flow Rate

Press the **Totalizer Flow Rate** button to display the flow rate.

Press the button a second time to display the total accumulation of water flow through the valve since the last reset.

Press the button a third time to return the display to **Time Of Day** or **Volume Remaining**.

- Press and hold the button for 25 seconds to reset the **Totalizer** display. During the 25 seconds, the **Totalizer** arrow flashes indicating that the display is resetting properly.

## Low Battery Indicator



Figure 15

The red Low Battery LED turns on whenever the 9V Alkaline Battery (not included) requires replacement. The battery is used for memory backup and is stored against the valve backplate. In the event of a power outage, the battery maintains the current operating displays for approximately 24 hours at maximum battery capacity.

## Immediate Regeneration Valves With Days Between Regeneration Override Set

When the valve reaches its set **Days Since Regeneration Override** value, a **Regeneration** cycle initiates immediately. This event occurs regardless of the **Volume Remaining** display reaching zero gallons.

## Delayed Regeneration Valves With Days Between Regeneration Override Set

When the valve reaches its set **Days Since Regeneration Override** value, a **Regeneration** cycle initiates at the preset **Regeneration Time**. This event occurs regardless of the **Volume Remaining** display reaching the calculated reserve capacity.

## Control Operation During Regeneration

In **Regeneration** the control displays a special **Regeneration** display. The control shows the current **Regeneration** step number to which the valve is advancing or has reached, and the time remaining in that step. The displayed step number flashes until the valve completes driving to the **Regeneration** step position. Once all **Regeneration** steps are complete the valve returns to **In Service** and resumes normal operation.

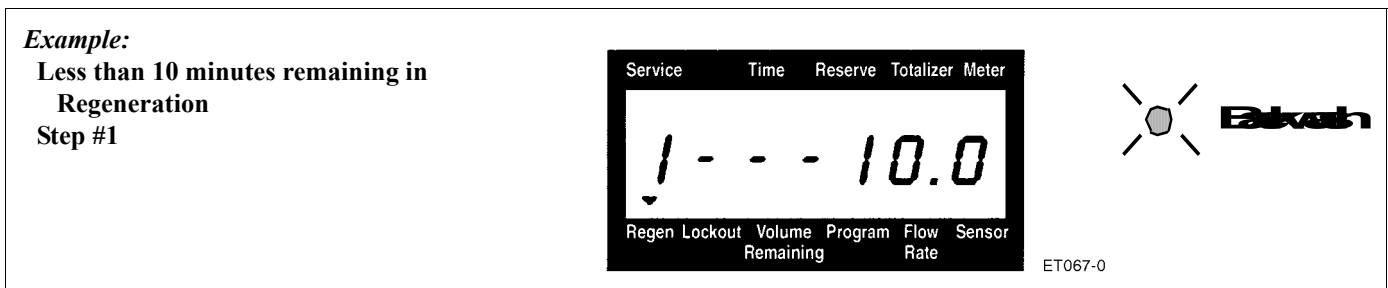

Figure 16



# Model 9000/9100/9500

---

Press the Extra Cycle button during a **Regeneration** cycle to immediately advances the valve to the next cycle step position and resume normal step timing.

## Control Operation During Programming

The control enters Program Mode with the valve **In Service**. While in Program Mode the control continues to operate normally, monitoring water usage and keeping all displays up to date. Control programming is stored in memory permanently. There is no need for battery backup power.

## Control Operation During A Power Failure

During a power failure all control displays and programming are stored for use upon power re-application. The control retains these values for years, if necessary, without loss. The control is fully inoperative and any calls for **Regeneration** are delayed. The control, upon power re-application, resumes normal operation from the point that it was interrupted. An inaccurate or flashing **Time of Day** display indicates that a power outage has occurred.

# Model 9000/9100/9500

## SE Timer Control Start-Up Procedures

### Display SE

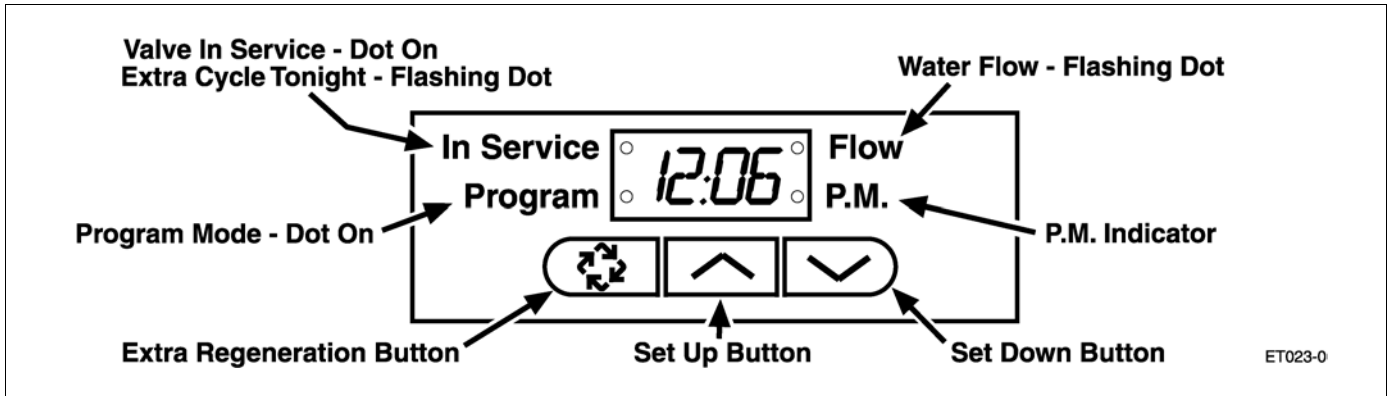

Figure 17: SE Timer Display

In normal operation the **Time Of Day** display alternates with **Volume Remaining** and Tank in **In Service** displays (9000SE Timer only). As treated water is used, the **Volume Remaining** display counts down (in gallons) from a maximum value to zero or (----). Once this occurs a **Regeneration** cycle initiates immediately or delayed to the set **Regeneration Time**. Water flow through the valve is indicated by the flashing **Flow Dot Indicator**.

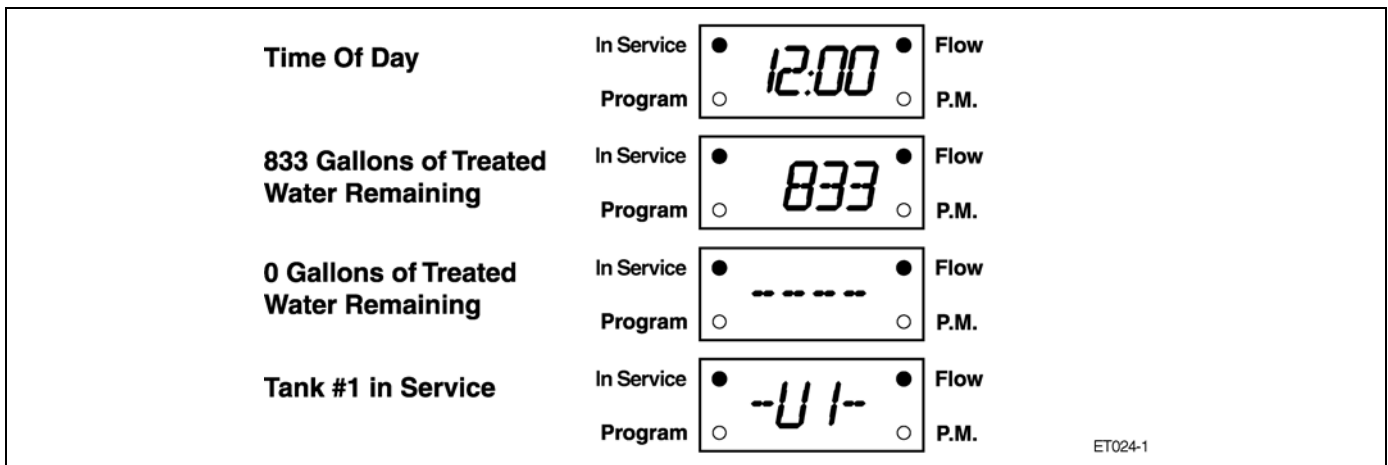

Figure 18: SE Timer Display During Normal Operation

### Set Time of Day



When the valve is **In Service**, press either the **Set Up** or **Set Down** button once to adjust the **Time Of Day** by one digit. Press and hold to adjust by several digits.

### Start an Extra Regeneration Cycle



Press the **Extra Regeneration** button to start an **Extra Regeneration** tonight. Press and hold the **Extra Regeneration** button for 5 seconds to start an **Extra Regeneration** immediately.

# Model 9000/9100/9500

## Set Control Programming

1. Press and hold both the **Set Up** and **Set Down** buttons for 5 seconds.

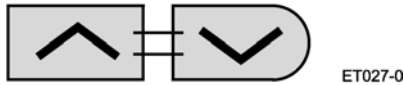

2. Set the Treated Water Capacity. Using the **Set Up** or **Set Down** buttons, set the amount of treated water to flow through the unit before a **Regeneration** is required.



3. Press the **Extra Regeneration** button.



4. Set the **Regeneration Time**. Use the **Set Up** or **Set Down** buttons to set the desired time of day for **Regeneration** to occur.

**NOTE:** This does not display if **Regeneration** occurs immediately.

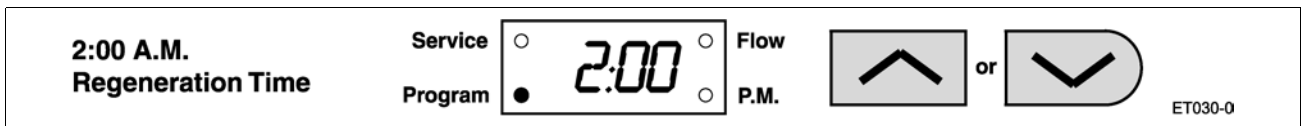

5. Press the **Extra Regeneration** button.



6. Set **Regeneration Day Override**. Use the **Set Up** or **Set Down** buttons to set the maximum number of days before a **Regeneration** cycle must occur.

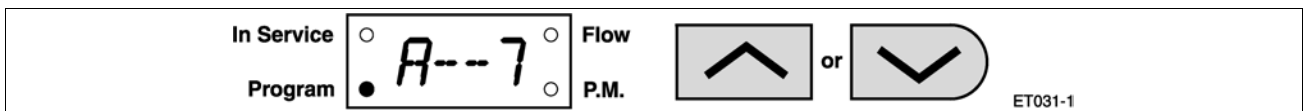

7. Press the **Extra Regeneration** button to exit the program.\*



**NOTE:** If setting up the system for the first time, perform the following **Fast Cycle Regeneration**:

1. Press the **Extra Regeneration** button for 5 seconds to force an **Extra Regeneration** immediately.
2. Once the valve reaches Regen Step #1, let water run to drain for approximately 5 minutes.
3. Press the **Extra Regeneration** button once to advance valve to Regen Step #2.
4. Press the **Extra Regeneration** button once to advance valve to Regen Step #3 (if active).
5. Press the **Extra Regeneration** button once to advance valve to Regen Step #4 (if active).
6. Press the **Extra Regeneration** button once to advance valve to Regen Step #5 (if active).
7. Press the **Extra Regeneration** button once more to advance the valve back to **In Service**.

# Model 9000/9100/9500

---

## Immediate Regeneration Valves With Days Between Regeneration Override Set

When the valve reaches its set **Days Since Regeneration Override** value, a **Regeneration** cycle initiates immediately. This event occurs regardless of the **Volume Remaining** display reaching zero gallons.

## Delayed Regeneration Valves With Days Between Regeneration Override Set

When the valve reaches its set **Days Since Regeneration Override** value a **Regeneration** cycle initiates at the preset **Regeneration Time**. This event occurs regardless of the **Volume Remaining** display reaching zero gallons.

## Control Operation During Regeneration

In **Regeneration** the control displays a special **Regeneration** display. While in **Regeneration** the control shows the current **Regeneration** step number to which the valve is advancing or has reached, and the time remaining in that step. The displayed step number flashes until the valve completes driving to this **Regeneration** step position. Once all **Regeneration** steps are complete the valve returns to **In Service** and resumes normal operation.

*Example:*

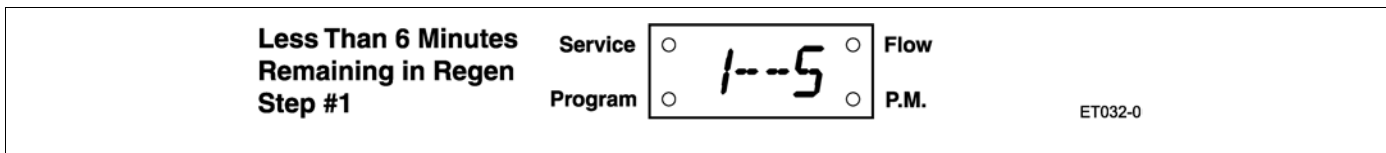

Figure 19

Pressing the **Extra Cycle** button during a **Regeneration** cycle immediately advances the valve to the next cycle step position and resumes normal step timing.

## Control Operation During Programming

The control only enters the **Program Mode** with the valve **In Service**. While in the **Program Mode** the control continues to operate normally monitoring water usage and keeping all displays up to date. Control programming is stored in memory permanently. There is no need for battery backup power.

## Control Operation During A Power Failure

During a power failure all control displays and programming are stored for use upon power re-application. The control retains these values for years, if necessary, without loss. The control is fully inoperative and any calls for **Regeneration** are delayed. The control, upon power re-application, resumes normal operation from the point that it was interrupted. An inaccurate or flashing **Time of Day** display indicates that a power outage has occurred.

# Model 9000/9100/9500

## *ET and SE Timer Assemblies*

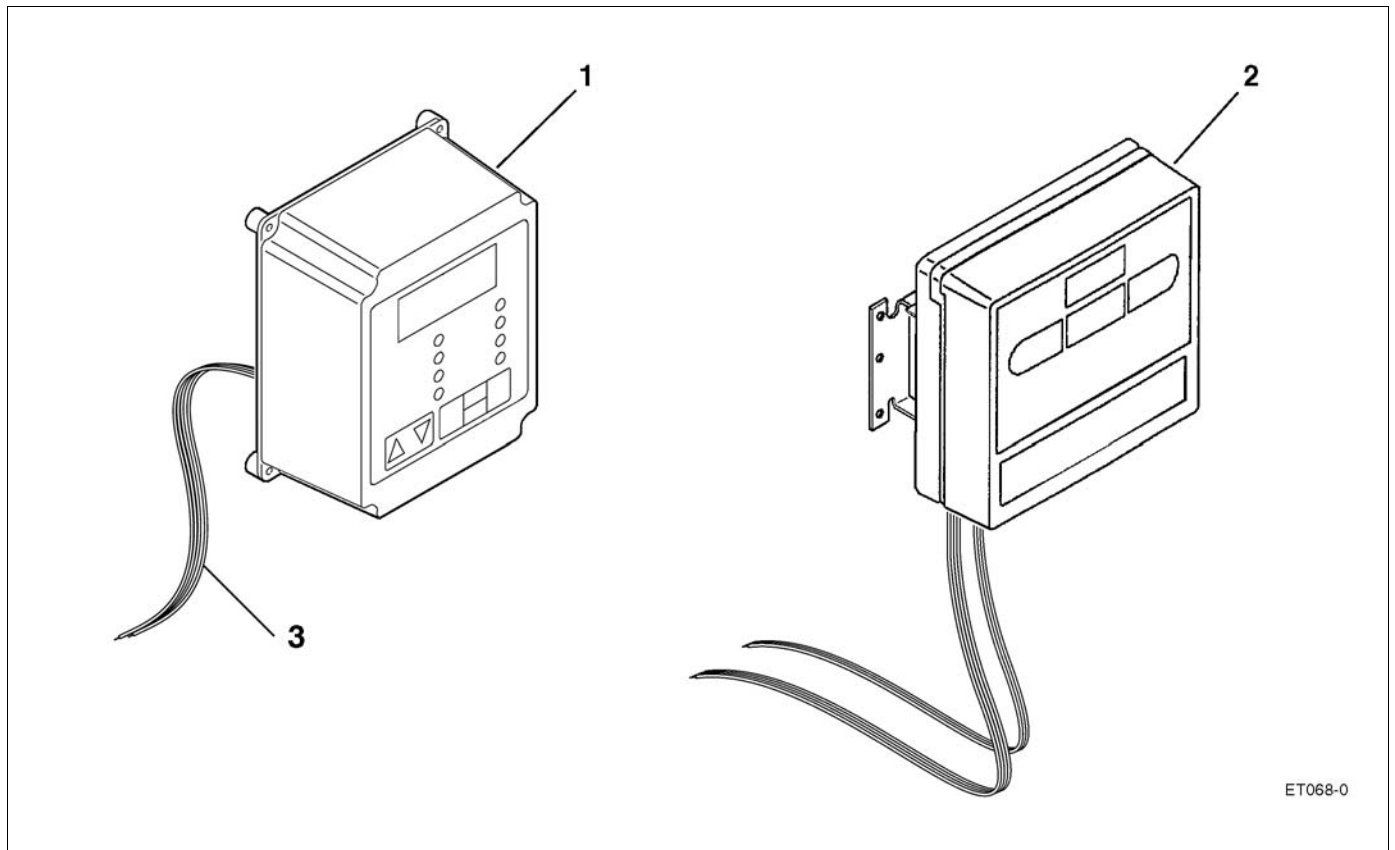

Figure 20

<i>Item</i>	<i>Quantity</i>	<i>Part Number</i>	<i>Description</i>
1	1	configured item	<i>ET</i> timer assembly
2	1	configured item	<i>SE</i> timer assembly
3	1	40427-03	wire harness

# Model 9000/9100/9500

## 9000/9100/9500 Electro Mechanical Timer Assembly

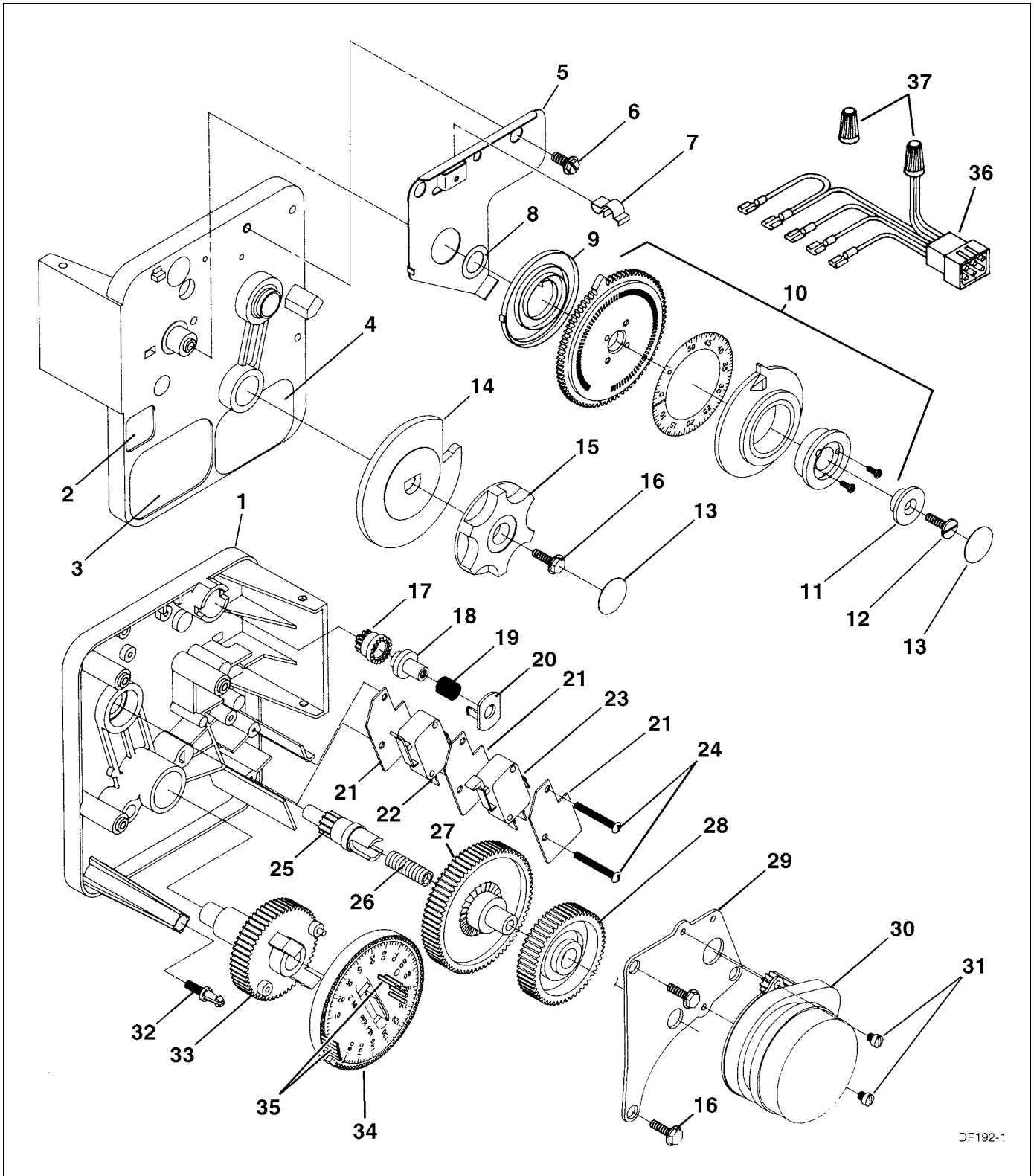

Figure 21

# Model 9000/9100/9500

## 9000/9100/9500 Electro Mechanical Timer Assembly

<i>Item</i>	<i>Quantity</i>	<i>PartNumber</i>	<i>Description</i>
1	1	13870-03	timer housing assembly.
2	1	17870	label, capacity gallons
3	1	15465	label, Caution
4	1	16930	label, Instruction
5	1	15227	actuator plate
6	1	10300	screw, hex washer #8
7	1	17513	spring clip
8	1	15407	washer, plain #4
9	1	15228	spring
10	1	16270-10	gallon wheel assembly 3/4" standard range meter
		16270-50	gallon wheel assembly 3/4" extended range meter
		16270-30	gallon wheel assembly 1" standard range meter
		16270-40	gallon wheel assembly 1" extended range meter
		16270-50	gallon wheel assembly 1-1/2" standard range meter
		16270-60	gallon wheel assembly 1-1/2" extended range meter
11	1	13806	program wheel retainer
12	1	13748	screw, flathead #6-20
13	2	11999	button decal
14	1	15223	cycle actuator gear
15	1	13886-01	knob
16	4	13296	screw, hex washer #6-20
17	1	17724	drive pinion
18	1	17723	drive pinion clutch
19	1	14276	spring, meter clutch
20	1	14253	retainer
21	3	14087	insulator
22	1	15314	switch
23	1	15320	switch
24	2	11413	screw, pan head #4-40
25	1	13018	idler shaft
26	1	18563	spring, idler shaft
27	1	13017	idler gear
28	1	13164	drive gear
29	1	13887	motor mounting plate
30	1	18743	motor, 120V 60 Hz.-1/30 RPM
		18824	motor, 220V 50 Hz.-1/30 RPM
		19170	motor, 120V 60 Hz.-1/15 RPM
		18825	motor, 220V 50 Hz.-1/15 RPM
31	2	13278	screw, #6-32
32	1	14265	spring clip
33	1	15055	main drive gear
34	1	19210-02	program wheel, 90 minute
		19210-05	program wheel, 180 minute
35	23	15493	roll pin
36	1	15203	harness
37	2	12681	wire nut
38	1	60320-02	auxiliary timer switch kit (not shown)

# Model 9000/9100/9500

## 9000/9100/9500 Power Head

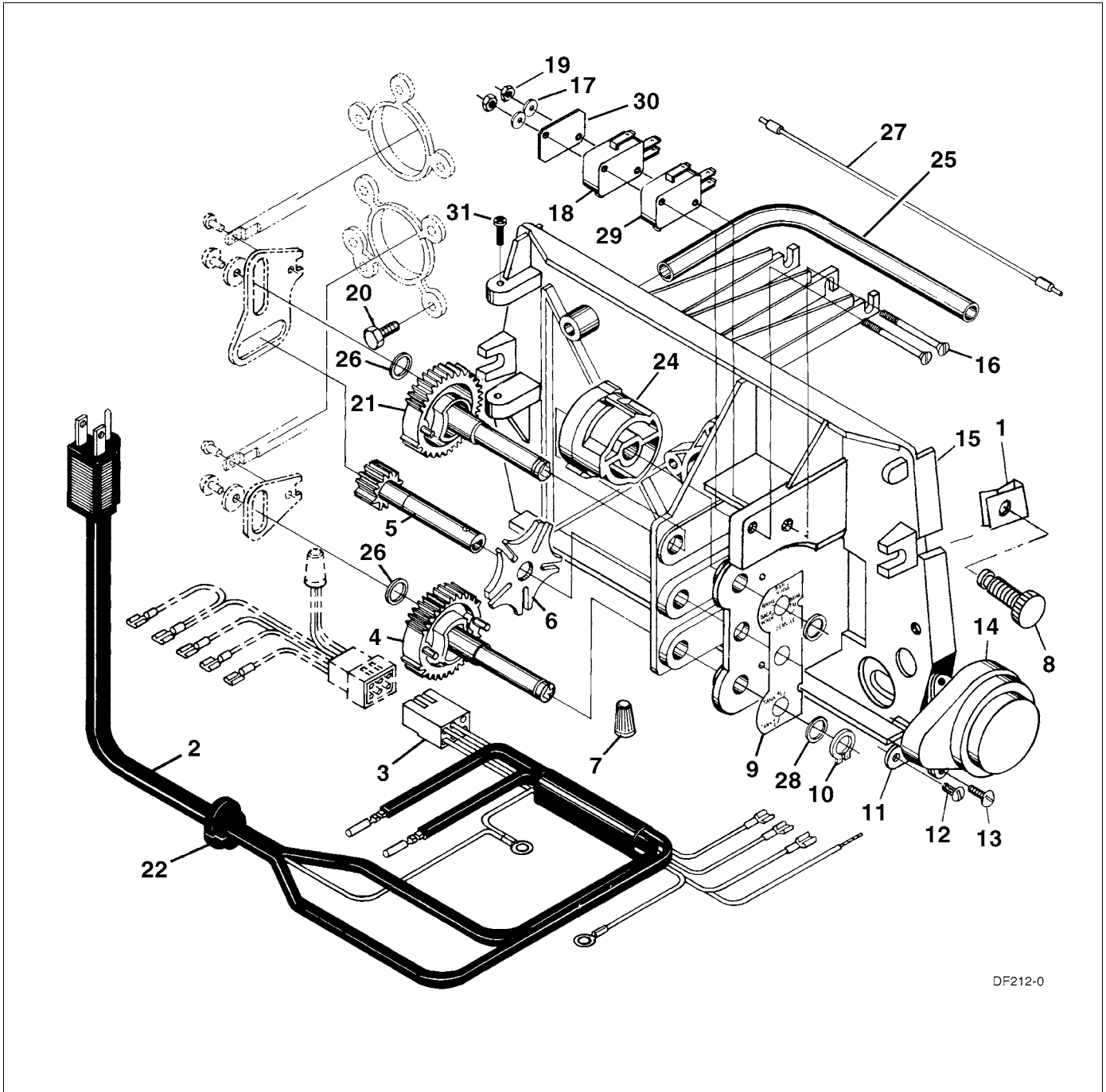

DF212-0

Figure 22



# Model 9000/9100/9500

## 9000/9100/9500 Power Head

<i>Item</i>	<i>Quantity</i>	<i>Part Number</i>	<i>Description</i>
1	2	18728	nut, clip #8-32
2	1	11838	power cord, 6' U.S. 120V
		11839	power cord, 12' U.S.120V
		40084-12	power cord, 12' U.S. 120V ( <i>ET</i> )
		11545-01	power cord, 5' European 220V
		14678	power cord, 6' U.S. 220V
		19303-01	power cord, Australian 8' 220V
		40085-12	power cord, 12' U.S. 220V ( <i>ET</i> )
		19674	transformer, U.S., 110V to 24V
		25651	transformer, European, 220V to 24V
3	1	15202	wire harness, mechanical
		14822	wire harness auxiliary drive switch
		40041-06	wire harness, low voltage ( <i>ET</i> )
4	1	15134	drive gear assembly, lower
5	1	15135	drive gear assembly
6	1	14896	geneva wheel
7	2	40422	wire connector
8	2	19367	cover screw
9	1	15175	position decal
10	2	14917	retaining ring
11	1	15199	ground plate
12	1	14430	screw, hex washer #6
13	2	19160	screw, motor mounting
14	1	18737	drive motor, 24V, 50/60 Hz (red wires)
	1	18738	drive motor, 120V, 60 Hz (black wires)
	1	18739	drive motor, 220V, 50 Hz (yellow wires)
15	1	15131	backplate, mechanical and <i>SE</i>
		17784-05	backplate, <i>ET</i>
		17784-06	backplate, <i>ET</i>
16	2	15172	screw, flat head #4-40
17	2	10340	washer, lock #4
18		10218	micro switch (homing)
19	1	10339	nut, micro switch
20	1	15331	screw, valve mounting
21	2	15133	drive gear assembly, upper
22	1	13547	strain relief
23	1	15810	retaining ring, drive gear
24	1	15132	triple cam ( <i>9000/9100</i> )
		17331	triple cam ( <i>9500</i> )
		17765	triple cam ( <i>9500</i> auxiliary switch)
25	1	15638	cable guide ( <i>9000/9100</i> )
	1	17337	cable guide ( <i>9500</i> )
26	2	15372	washer, thrust
27	1	15216	meter cable, 15.25", 1" meter, mechanical
		15425	meter cable, 13.25", 3/4" meter, mechanical
		17744	meter cable, 20.75", 1-1/2" meter, mechanical
		19121-01	meter cable, 1" meter, <i>SE</i>
		19121-05	meter cable, 3/4" and 1" meter, <i>ET</i>
		19791-01	meter cable, 1" meter, <i>SE</i>
28	2	15692	spacer
29	1	16433	micro switch (program)
30	1	10302	insulator
31	2	15173	screw
<i>Not Shown</i>			
32	1	60232-110	cover, black
	1	60232-112	cover, black - left window
33	1	60320-09	optional auxiliary drive switch ( <i>9000/9100</i> )
	1	60320-10	optional auxiliary drive switch ( <i>9500</i> )

# Model 9000/9100/9500

## 9000 Control Valve Assembly

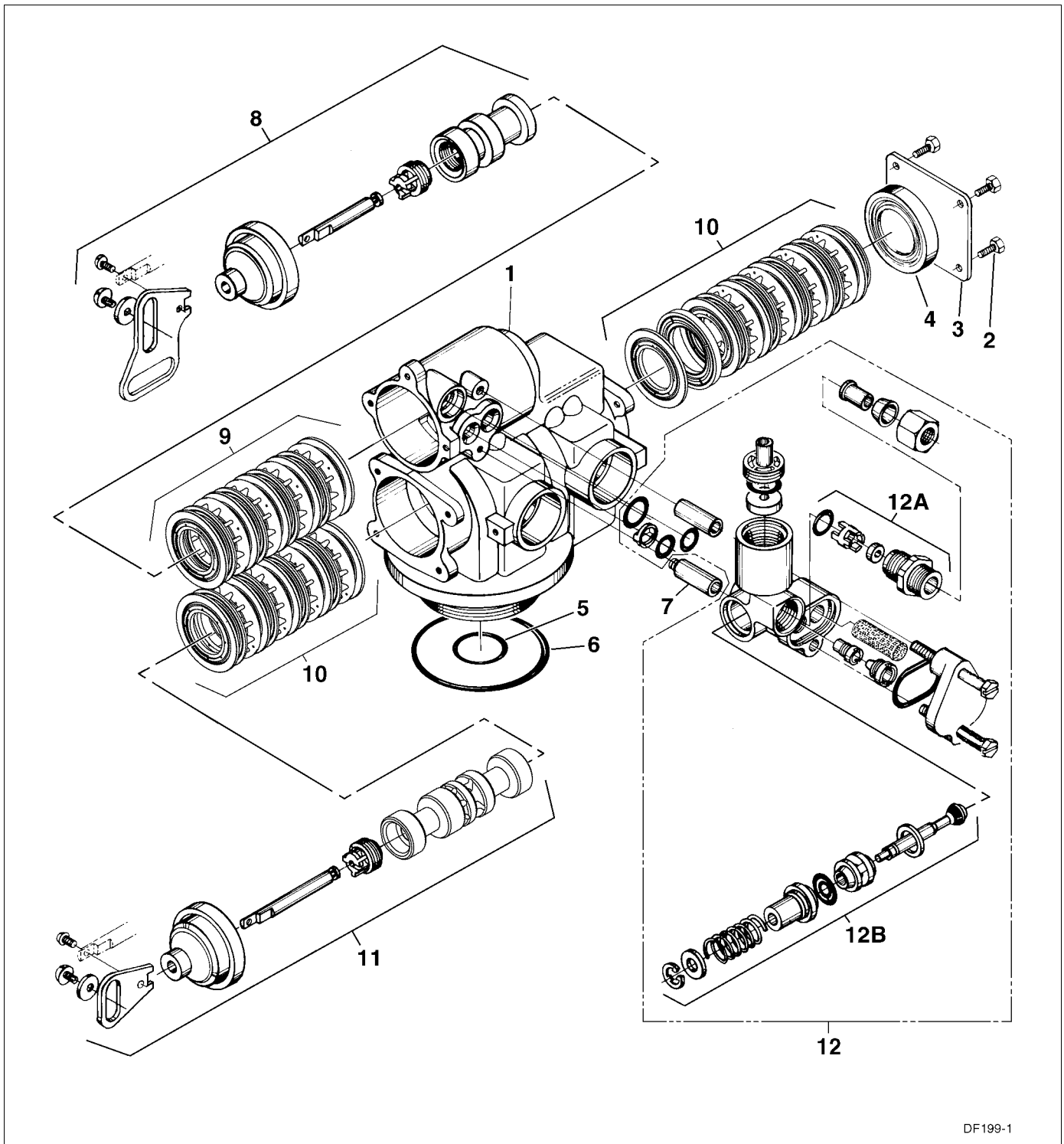

Figure 23

# Model 9000/9100/9500

## 9000 Control Valve Assembly

<i>Item</i>	<i>Quantity</i>	<i>Part Number</i>	<i>Description</i>
1	1	14861-01	valve body, machined
	1	14861-01NP	valve body, machined (nickel plated)
2	4	15137	screw, hex washer #10-24 x 3/8"
3	1	14906	end plate
4	1	14928	end plug
5			
6			
7	1	15471	stand off
8	1	60400	piston assembly, top
	1	60400-01	piston assembly, top (hot water)
9	1	60125	seal and spacer kit, top
		60125-HW	seal and spacer kit, top (hot water)
		60125-20	seal and spacer kit, top (559PE)
10	1	60421	seal and spacer kit, bottom
		60421-HW	seal and spacer kit, bottom (hot water)
		60421-20	seal and spacer kit, (559PE)
11	1	60401	piston assembly, bottom
		60401-01	piston assembly, bottom (hot water)
12	1	60385-XXXX	injector assembly (see chart for dash numbers)

<i>injector number</i>	<i>DLFC</i>	<i>injector number</i>	<i>BLFC</i>	<i>number</i>
red #0	00	Blank	0	Blank
white #1	01	1.2	1	0.25
blue #2	02	1.5	2	0.50
yellow #3	03	2.0	3	1.00
green #4	04	2.4	4	
		3.0	5	
		3.5	6	
		4.0	7	
		5.0	8	
		7.0	9	

12A	1	60022-12	brine line flow control assembly, 0.125 gpm
		60022-25	brine line flow control assembly, 0.250 gpm
		60022-50	brine line flow control assembly, 0.500 gpm
		60022-100	brine line flow control assembly, 1.00 gpm
12B	1	60350	brine valve assembly
<i>Not Shown</i>			
13		12763	seal and space stuffer tool
14		13061	spacer puller tool
15		13759	DLFC retainer tool

# Model 9000/9100/9500

## 9100 Control Valve Assembly

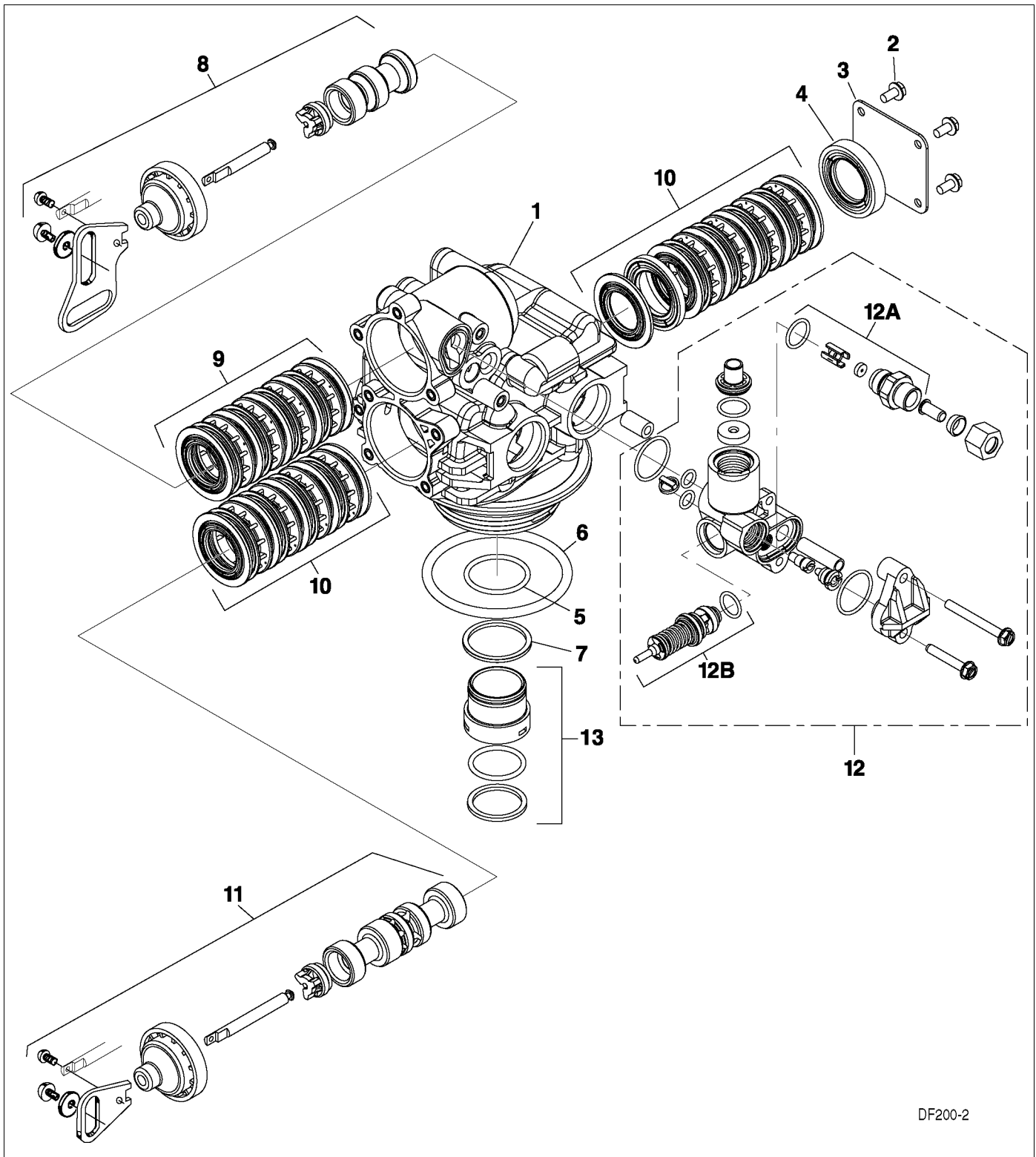

DF200-2

Figure 24

# Model 9000/9100/9500

## 9100 Control Valve Assembly

<i>Item</i>	<i>Quantity</i>	<i>Part Number</i>	<i>Description</i>
1	1	40688	valve body assembly
2	4	15137	screw, hex washer #10-24 x 3/8"
3	1	14906	end plate
4	1	14928	end plug
5	1	19054	O-ring, 124
6	1	18303	O-ring, 336
7	1	40538	retainer, 32mm
8	1	60400	piston top assembly
9	1	60125	seal and spacer kit, top
	1	60125-20	seal and spacer kit, top (559PE)
10	1	60421	seal and spacer kit, bottom
	1	60421-20	seal and spacer kit, bottom (559PE)
11	1	60401	piston assembly, bottom
12	1	60385-XXXX	injector assembly (see following chart for dash numbers)

<i>injector</i>	<i>number</i>	<i>DLFC</i>	<i>number</i>	<i>BLF C</i>	<i>number</i>
red #0	00	Blank	0	Blank	0
white #1	01	1.2	1	0.25	1
blue #2	02	1.5	2	0.50	2
yellow #3	03	2.0	3	1.00	3
green #4	04	2.4	4		
		3.0	5		
		3.5	6		
		4.0	7		
		5.0	8		
		7.0	9		

12A	1	60022-12	brine line flow control assembly, 0.125 gpm
		60022-25	brine line flow control assembly, 0.250 gpm
		60022-50	brine line flow control assembly, 0.500 gpm
		60022-100	brine line flow control assembly, 1.00 gpm
12B	1	60350	brine valve assembly
13	1	61419	distributor adapter kit, 1.05"

*Not Shown*

14		12763	seal and space stuffer tool
15		13061	spacer puller tool
16		13759	DLFC retainer tool

# Model 9000/9100/9500

## 9500 Control Valve Assembly

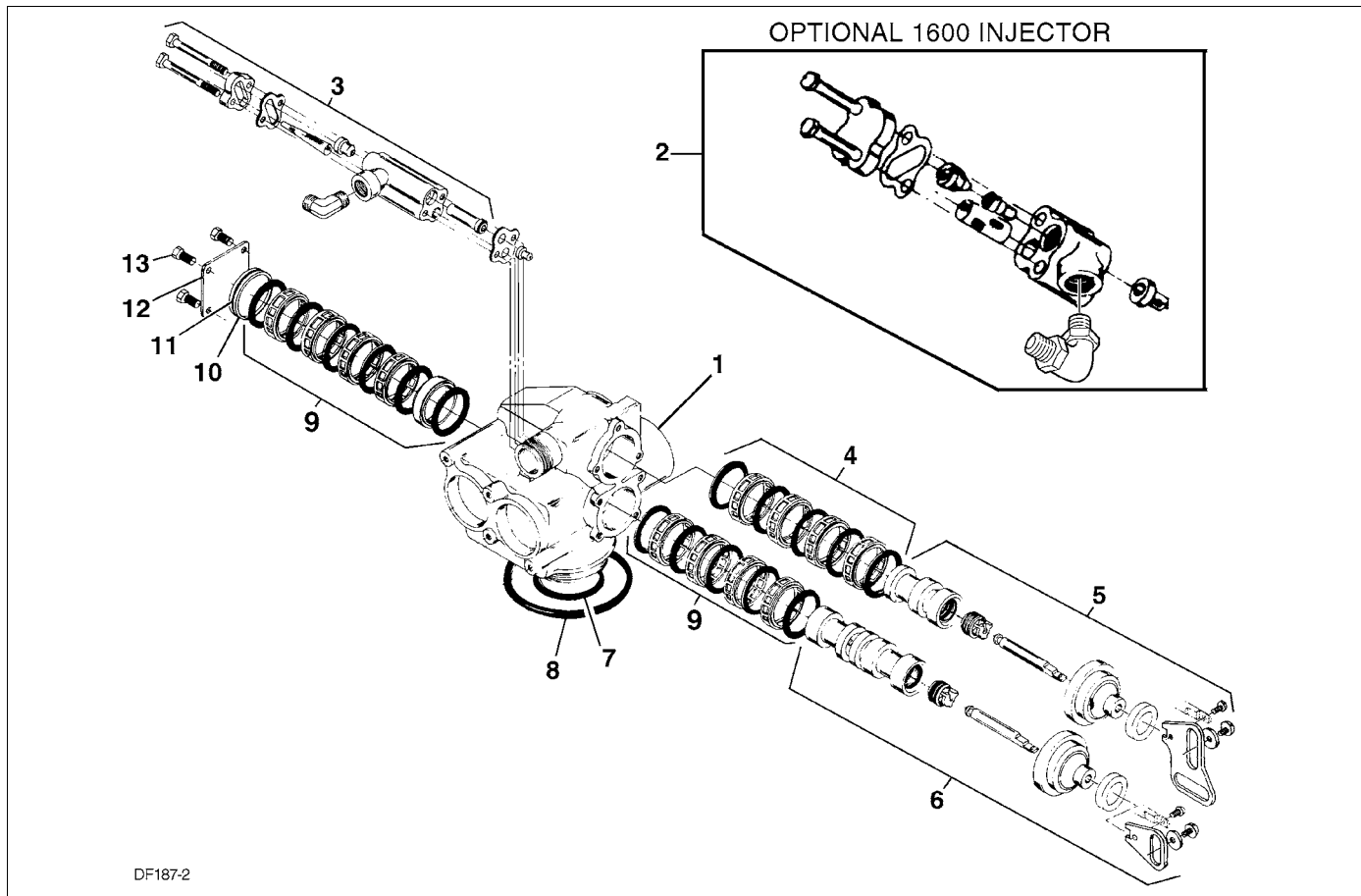

Figure 25

Item	Quantity	PartNumber	Description
1	1	16919-01	valve body <b>9500</b> NPT, mechanical base
		16919-01NP	valve body <b>9500</b> NPT, mechanical base, nickel-plated
		16919-21	valve body <b>9500</b> BSP/Metric, mechanical base
		16919-21NP	valve body <b>9500</b> BSP/Metric, mechanical base, nickel-plated
2	1	60080-XX	injector assembly (see chart for dash numbers)
3	1	60039-XX	injector assembly (see chart for dash numbers)
4	1	60134	seal and spacer kit, top
		60134-01	seal and spacer kit, top, hot water
		60134	seal and spacer kit, top, silicone
5	1	60108	piston assembly, top
		60108-01	piston assembly, top, hot water
6	1	60109	piston assembly, bottom
		60109-01	piston assembly, bottom, hot water
7	1	60133	seal and spacer kit, bottom
		60133-01	seal and spacer kit, bottom, hot water
		60133-10	seal and spacer kit, bottom, silicone
8	1	16455	O-ring, 347
9	1	13577	O-ring, 226
10	1	16955	end plug
11	1	16394	O-ring, 029
12	1	14906	end plate
13	4	15137	screw, hex washer machine, 1-24 x 3/8
		17657	screw, hex M5-40, Metric
<i>Not Shown</i>			
14		16516	tool, seal and spacer stuffer
15		17623	tool, spacer puller

injector	number
blue #2	02
yellow #3	03
green #4	04
white #5	05

# Model 9000/9100/9500

## 9500 Brine Valve Systems (1600 and 1700 Series)

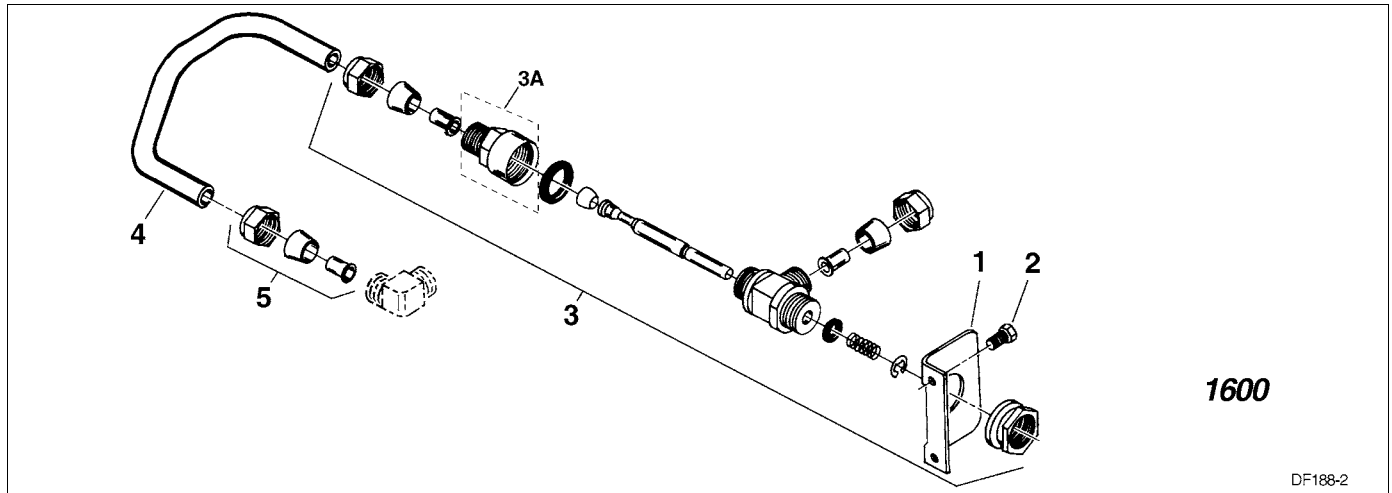

Figure 26

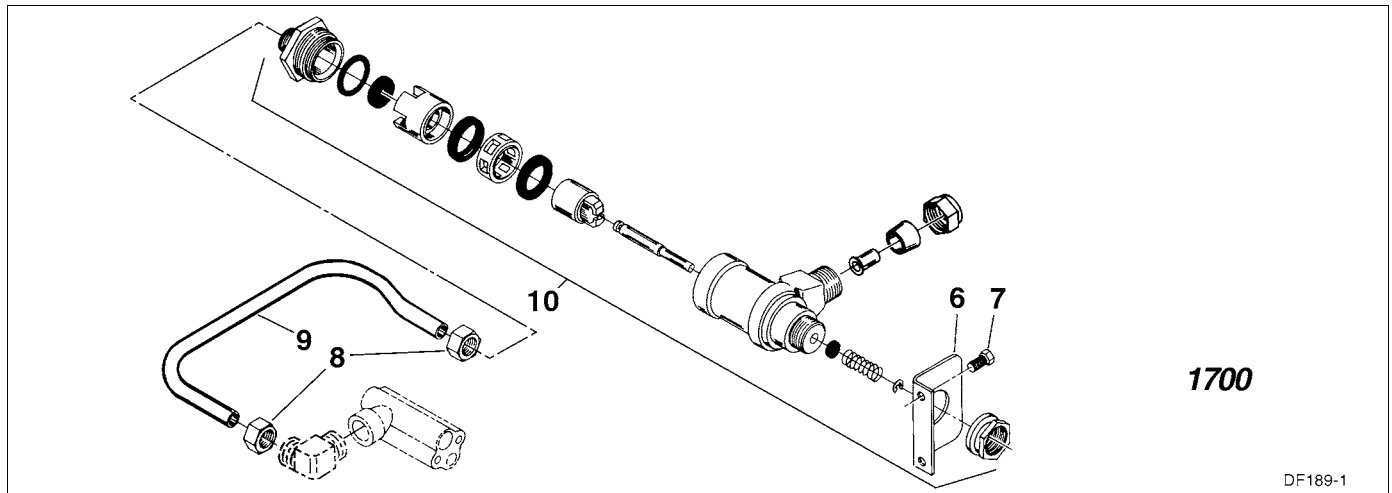

Figure 27

Item	Quantity	Part Number	Description	
1	1	16922	bracket, brine valve	<i>1600 Series Brine System</i>
2	2	15137	screw, brine valve bracket	
3	1	60037-610	brine valve assembly, 0.25 gpm	
		60020-620	brine valve assembly, 0.50 gpm	
		60020-630	brine valve assembly, 1.00 gpm	
		60020-690	brine valve assembly, blank	
		60037HW	brine valve assembly, hot water	
3A	1	60020-25	brine line flow control assembly, 0.25 gpm	
		60020-50	brine line flow control assembly, 0.50 gpm	
		60020-100	brine line flow control assembly, 1.00 gpm	
4	1		tube, brine valve	
5	1		adapter kit	
6	1	16922	bracket, brine valve	<i>1700 Series Brine System</i>
7	2	15137	screw, brine valve bracket	
8	2	15414	nut, tube	
9	1	16959	tube, brine valve	
10	1	60039-00	brine valve assembly, blank	
		60039-10	brine valve assembly, 1.0 gpm	
		60039-12	brine valve assembly, 1.2 gpm	
		60039-15	brine valve assembly, 1.5 gpm	
		60039-20	brine valve assembly, 2.0 gpm	
		60039-24	brine valve assembly, 2.4 gpm	
		60039-30	brine valve assembly, 3.0 gpm	
		60039-35	brine valve assembly, 3.5 gpm	
		60039-40	brine valve assembly, 4.0 gpm	

# Model 9000/9100/9500

## 9000/9100/9500 Second Tank Assemblies

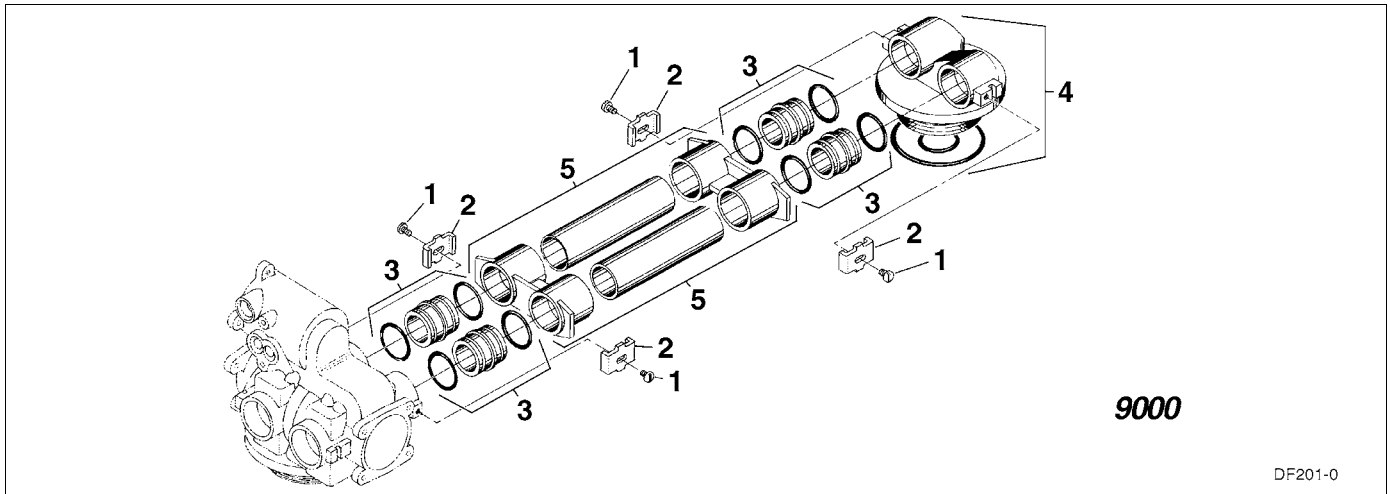

Figure 28

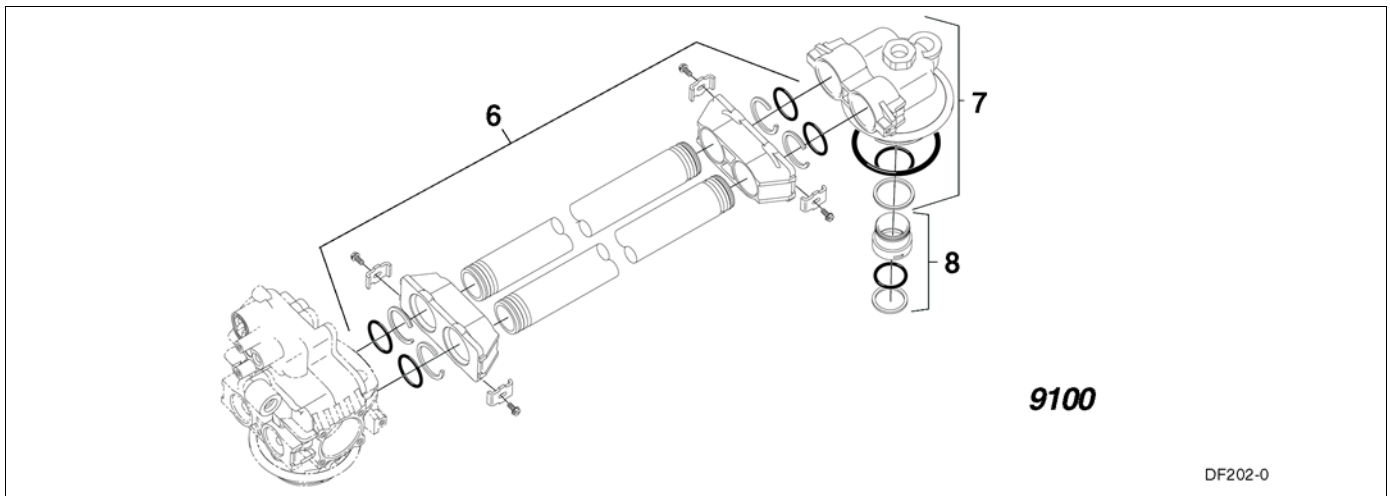

Figure 29

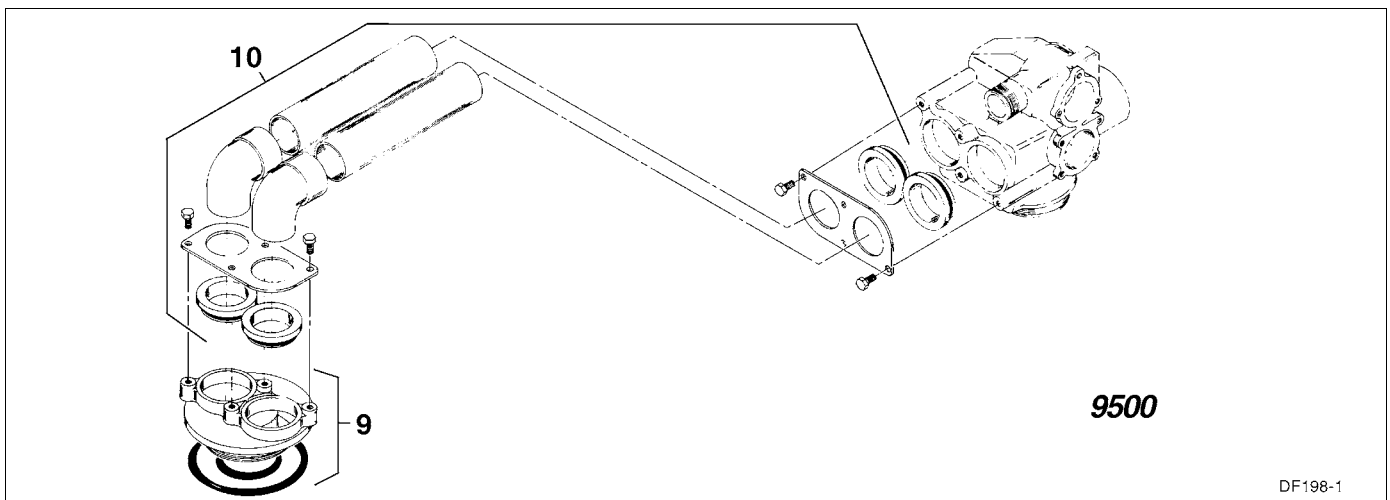

Figure 30



# Model 9000/9100/9500

## *9000/9100/9500 Second Tank Assemblies*

<i>Item</i>	<i>Quantity</i>	<i>Part Number</i>	<i>Description</i>
			<b><i>9000 second tank assembly</i></b>
1	4	14202-01	screw, hex head #8-32
2	4	13255	clip, hold-down
3	4	15078-01	coupling assembly, <b>9000</b>
4	1	14864-01	second tank adapter assembly, <b>9000</b>
		14864-01NP	second tank adapter assembly, <b>9000</b> , nickel-plated
5	1	15823-06	yoke assembly 6" tanks, 6" tubes
		15823-06NP	yoke assembly 6" tanks, 6" tubes, nickel-plated
		15823-12	yoke assembly 12" tanks, 8-1/2" tubes
		15823-12NP	yoke assembly 12" tanks, 8-1/2" tubes, nickel-plated
		15823-14	yoke assembly 14" tanks, 10-1/2" tubes
		15823-14NP	yoke assembly 14" tanks, 10-1/2" tubes, nickel-plated
		15823-16	yoke assembly 16" tanks, 12-1/2" tubes
		15823-16NP	yoke assembly 16" tanks, 12-1/2" tubes, nickel-plated
			<b><i>9100 second tank assembly</i></b>
6	1	60425-12	plastic tube assembly, <b>9100</b> , up to 12" tanks
		60425-16	plastic tube assembly, <b>9100</b> , up to 16" tanks
7	1	14865	second tank adapter assembly, <b>9100</b>
8	1	61419	distributors adapter kit, <b>9100</b> , 1.05"
			<b><i>9500 second tank assembly</i></b>
9	1	16919-01	second tank adapter assembly, <b>9500</b>
		16919-01NP	second tank adapter assembly, <b>9500</b> , nickel-plated
		16919-21	second tank adapter assembly, <b>9500</b> , BSP/Metric
		16919-21NP	second tank adapter assembly, <b>9500</b> , BSP/Metric, nickel-plated
10	1	60715-16	tube assembly 16" tanks
		60715-16NP	tube assembly 16" tanks, nickel-plated
		60715-20	tube assembly 20" tanks
		60715-20NP	tube assembly 20" tanks, nickel-plated
		60715-24	tube assembly 24" tanks
		60715-24NP	tube assembly 24" tanks, nickel-plated

# Model 9000/9100/9500

## 9000/9100/9500 Meter Assemblies

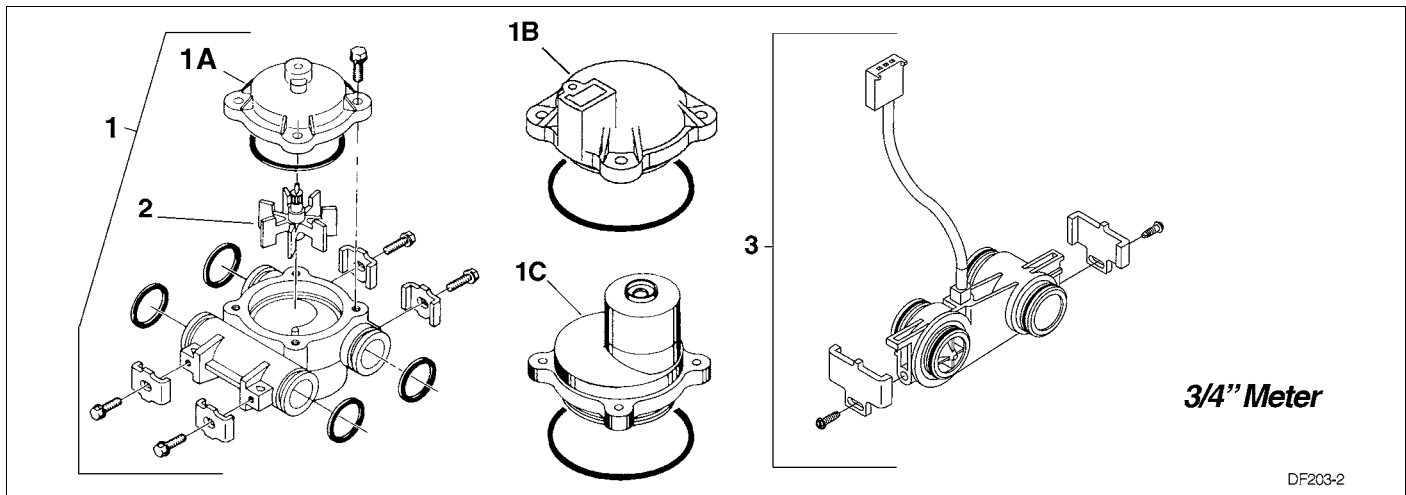

Figure 31

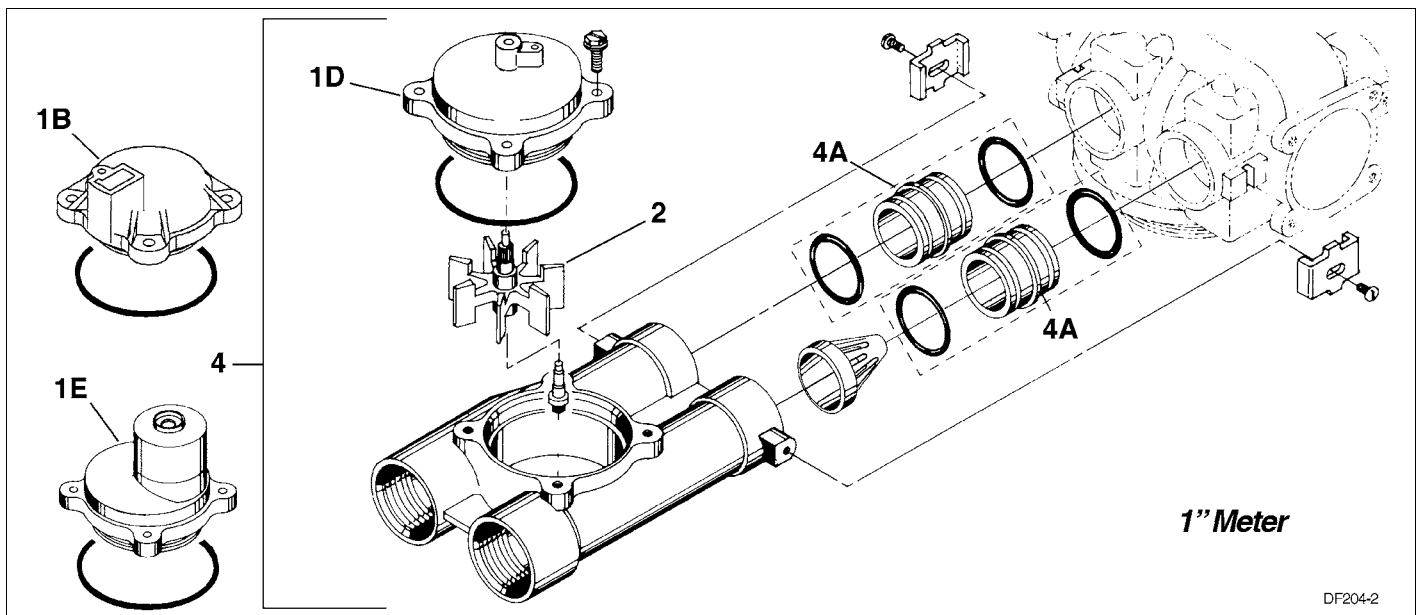

Figure 32

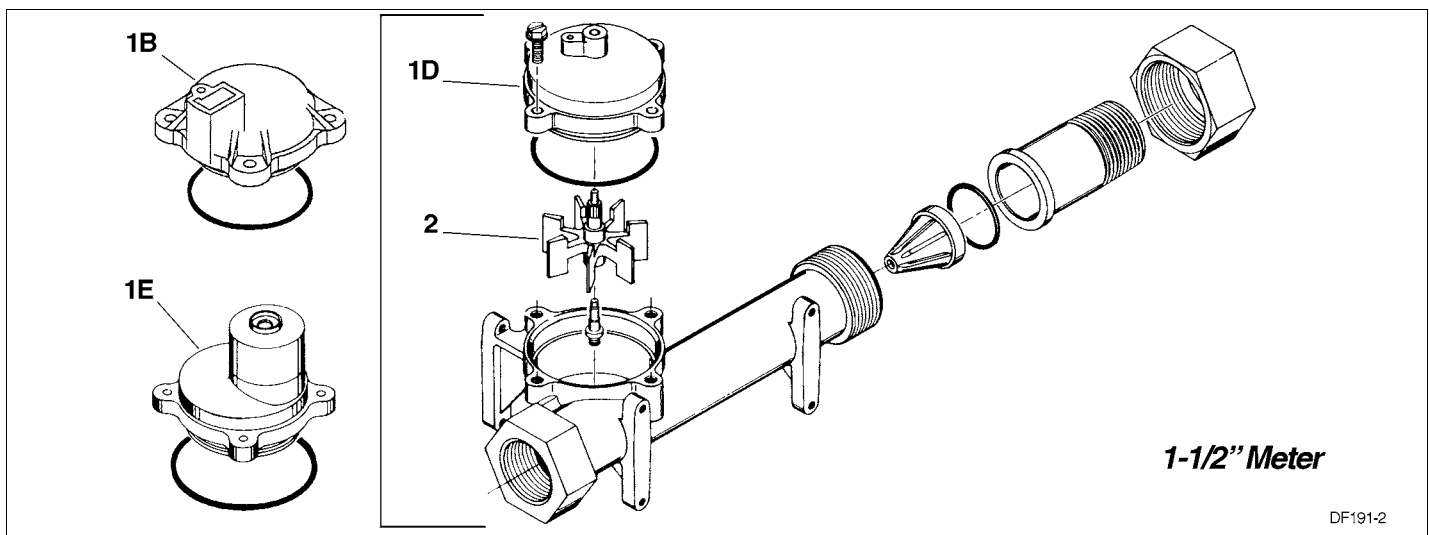

Figure 33

# Model 9000/9100/9500

## 9000/9100/9500 Meter Assemblies

<i>Item</i>	<i>Quantity</i>	<i>Part Number</i>	<i>Description</i>
<i>9000 meter assembly</i>			
1	1	60086	3/4" meter assembly, standard range
		60086-50	3/4" meter assembly, electronic ( <i>ET</i> )
		60087	3/4" meter assembly, extended range
1A	1	14038	meter cap assembly, standard range
1B		14716	meter cap assembly, electronic ( <i>ET</i> )
1C		15150	meter cap assembly, extended range
1D	1	15218	meter cap assembly, brass standard range
		15218NP	meter cap assembly, brass nickel-plated standard range
1E		15237	meter cap assembly, brass extended range
		15237NP	meter cap assembly, brass nickel-plated extended range
2	1	13509	impeller
		13509-01	impeller, hot water
3	1	19797	3/4" turbine meter assembly, less clips and screws
		60626	3/4" turbine meter assembly with clips, screws, meter cable
		60626-01	3/4" turbine meter assembly, with clips and screws
4	1	60389	1" meter assembly, standard range
		60389NP	1" meter assembly, standard range
	1	60389-20	1" meter assembly, standard range, BSP
		60390	1" meter assembly, extended range
		60390NP	1" meter assembly, extended range, nickel-plated
		60390-20	1" meter assembly, extended range, BSP
		60612	1" meter assembly, standard range, hot water
		60622	1" meter assembly, electronic
4A	1	15078	1" adapter coupling
5	1	60610-01	1-1/2" meter assembly, standard range
		60610-01NP	1-1/2" meter assembly, standard range, nickel-plated
		60610-02	1-1/2" meter assembly, extended range
		60610-02NP	1-1/2" meter assembly, extended range, nickel-plated
		60610-21	1-1/2" meter assembly, standard range, BSP
		60610-21NP	1-1/2" meter assembly, standard range, BSP, nickel-plated
		60610-22	1-1/2" meter assembly, extended range, BSP
		60610-22NP	1-1/2" meter assembly, extended range, BSP, nickel-plated
		60611-01	1-1/2" meter assembly, standard range, with 1" sleeve
		60611-01NP	1-1/2" meter assembly, standard range, with 1" sleeve, nickel-plated
		60611-02	1-1/2" meter assembly, extended range, with 1" sleeve
		60611-02NP	1-1/2" meter assembly, extended range, with 1" sleeve, nickel-plated
<i>Not Shown</i>			
6*		17790	1-1/2" meter sleeve reduced to 1"
7		60460	meter checker kit, standard range
8		60461	meter checker kit, extended range

\* when reducing 1-1/2" meter to 1" program wheel and timer settings must be changed to 1" meter size

# Model 9000/9100/9500

## 9000/9100 Bypass Valve

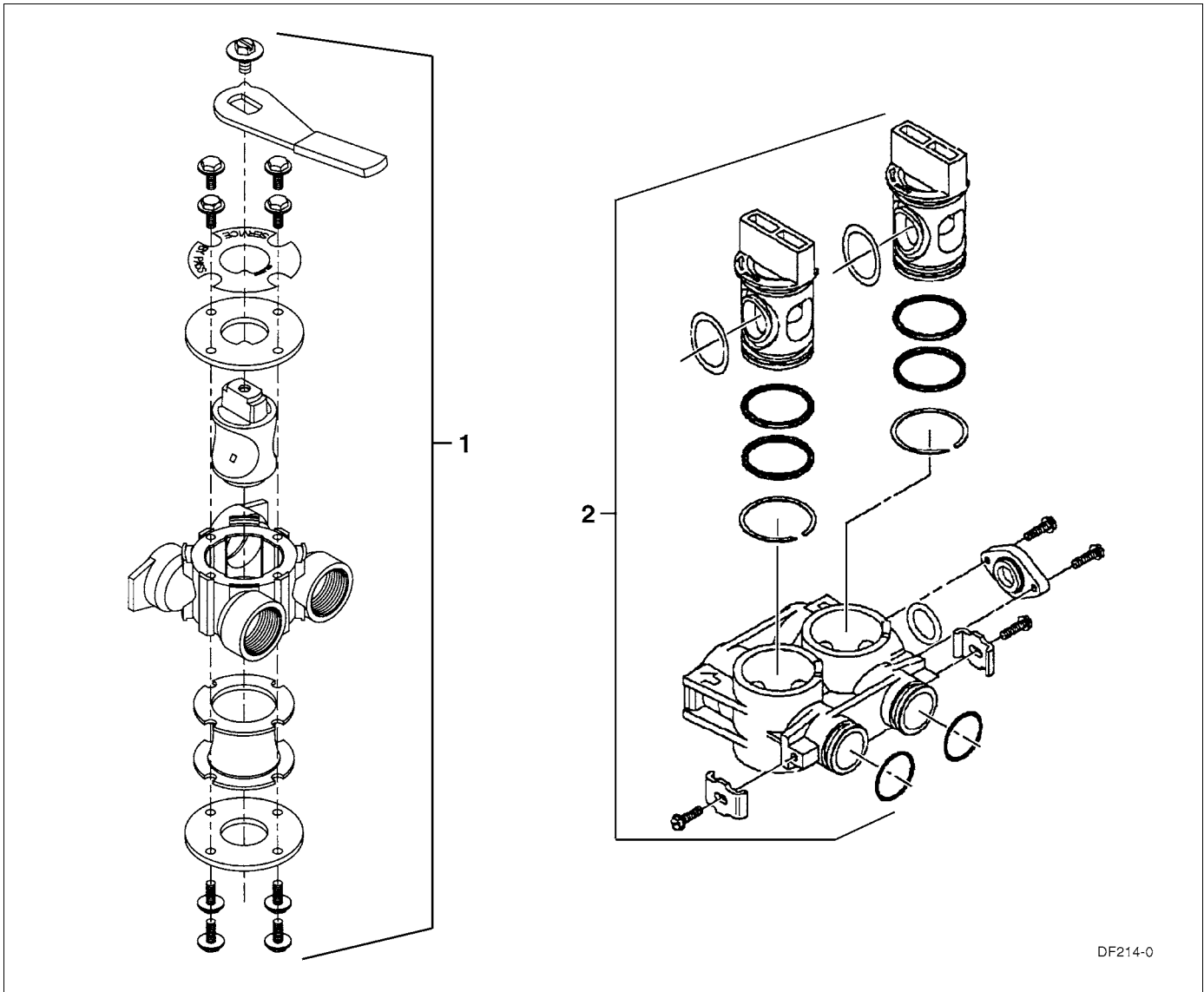

Figure 34

Item	Quantity	Part Number	Description
1	1	60040SS	3/4" bypass valve NPT
		60040-10	3/4" bypass valve BSP
		60041SS	1" bypass valve NPT
		60041-10	1" bypass valve BSP
2	1	60049	plastic bypass valve
Not Shown			
3		40157	plastic bypass T-handle wrench

# Model 9000/9100/9500

## 2310 Safety Brine Valve

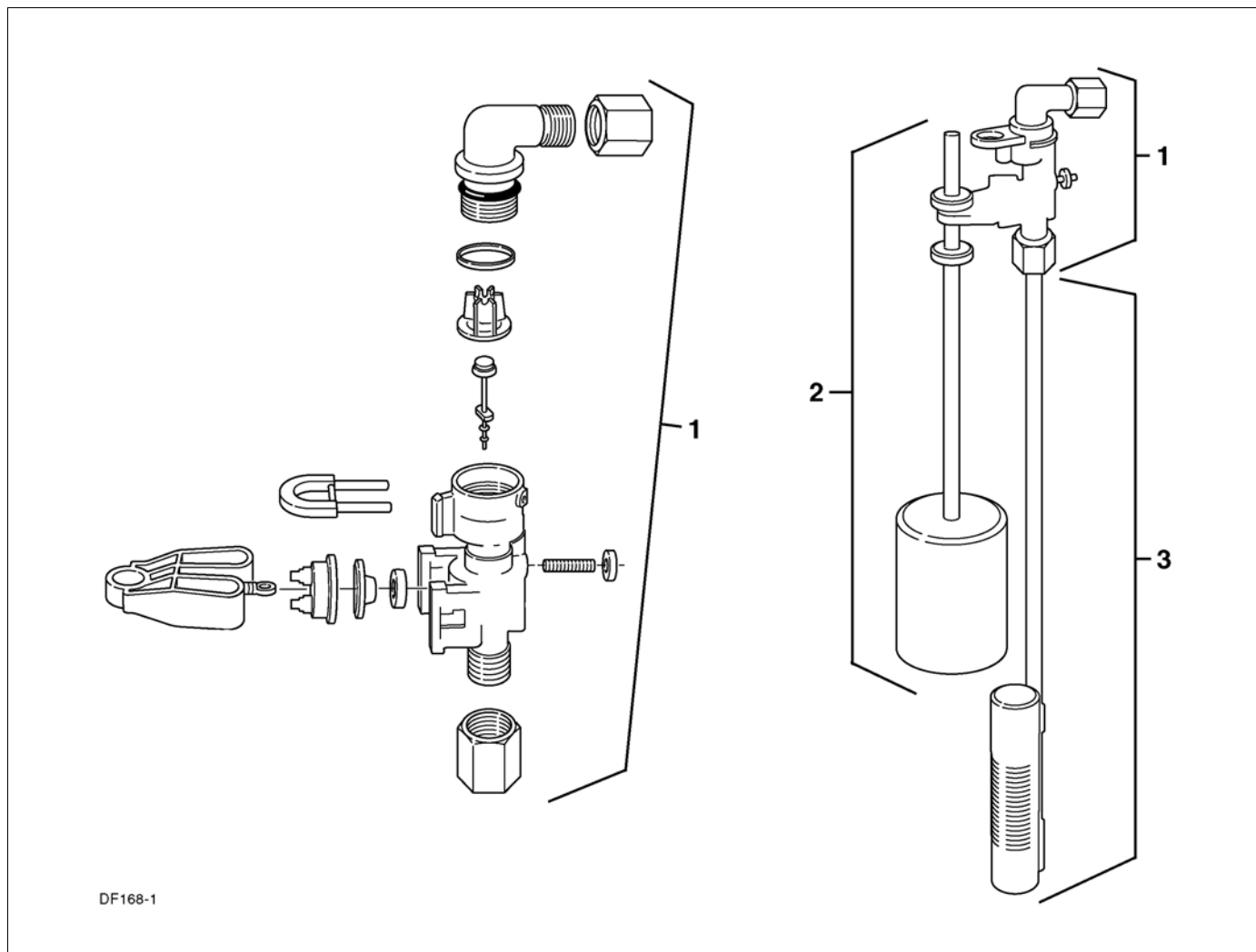
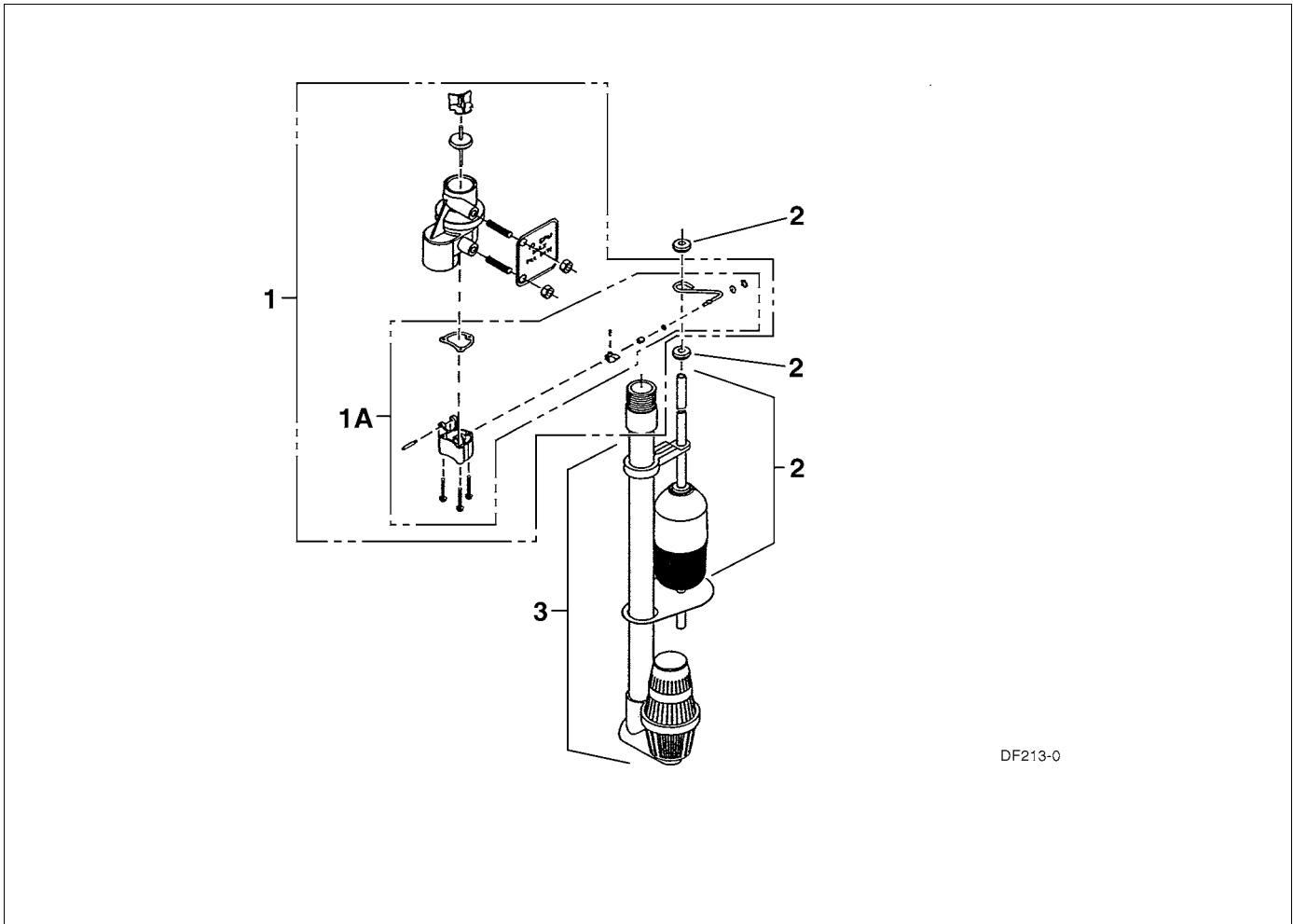

Figure 35

<i>Item</i>	<i>Quantity</i>	<i>Part Number</i>	<i>Description</i>
1	1	60014	2310 safety brine valve
2	1	60068	2310 float assembly
		60026-30	float assembly red/white (float fill)
3	1	60002	#500 air check

# Model 9000/9100/9500

## 9500, 2350 Safety Brine Valve



DF213-0

Figure 36

<i>Item</i>	<i>Quantity</i>	<i>Part Number</i>	<i>Description</i>
1	1	60038	2350 safety brine valve
1A	1	61024	2350 actuator assembly
2	1	60026-30	float assembly red/white
		60076-30SAN	float assembly green/green (hot water)
3	1	60009-00	#900 air check
	1	60009-01	#900 air check hot water
<i>Not Shown</i>			
4		18603	2350 fittings for 1700 brine system
5		18604	#900 fittings for 1700 brine system

# Model 9000/9100/9500

## 2300 Safety Brine Valve

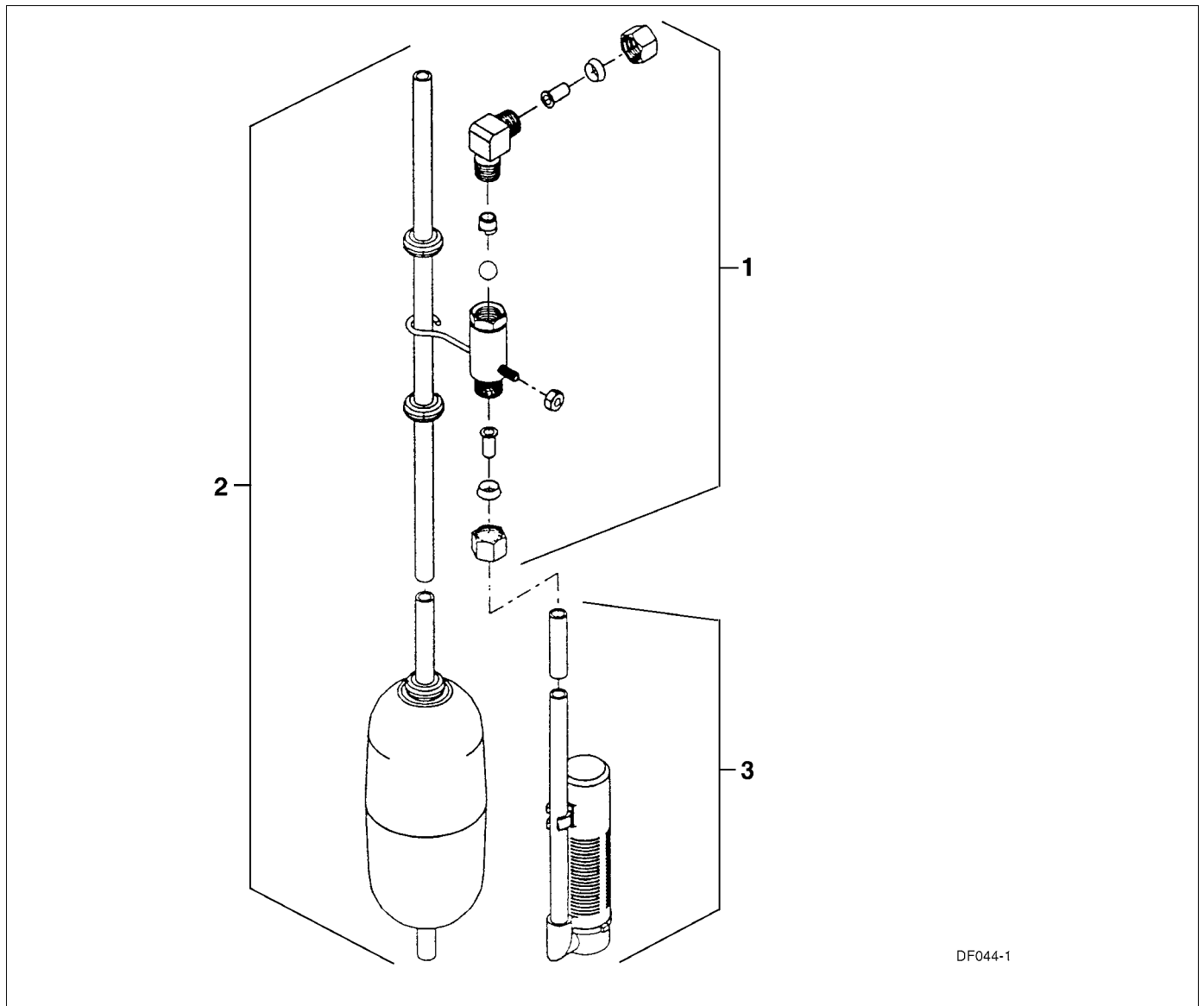

Figure 37

<i>Item</i>	<i>Quantity</i>	<i>Part Number</i>	<i>Description</i>
1	1	60027-FFA	2300 safety brine valve, fitting facing arm
		60027-FFS	2300 safety brine valve, fitting facing stud
2	1	60028-30	float assembly blue/white
		60026-30SAN	float assembly green/green, hot water
3	1	60002	#500 air check
		60003	#500 air check, hot water

# Model 9000/9100/9500

## Water Conditioner Flow Diagrams

### In Service Position

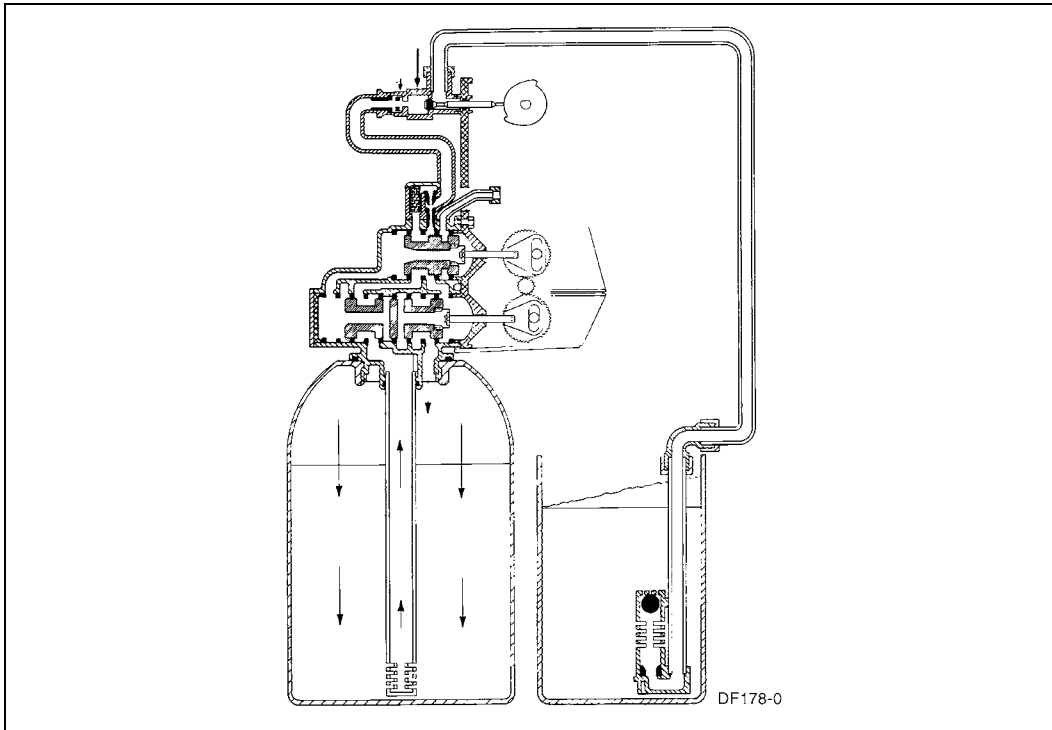

Figure 38: In Service Position

### Tanks Switching

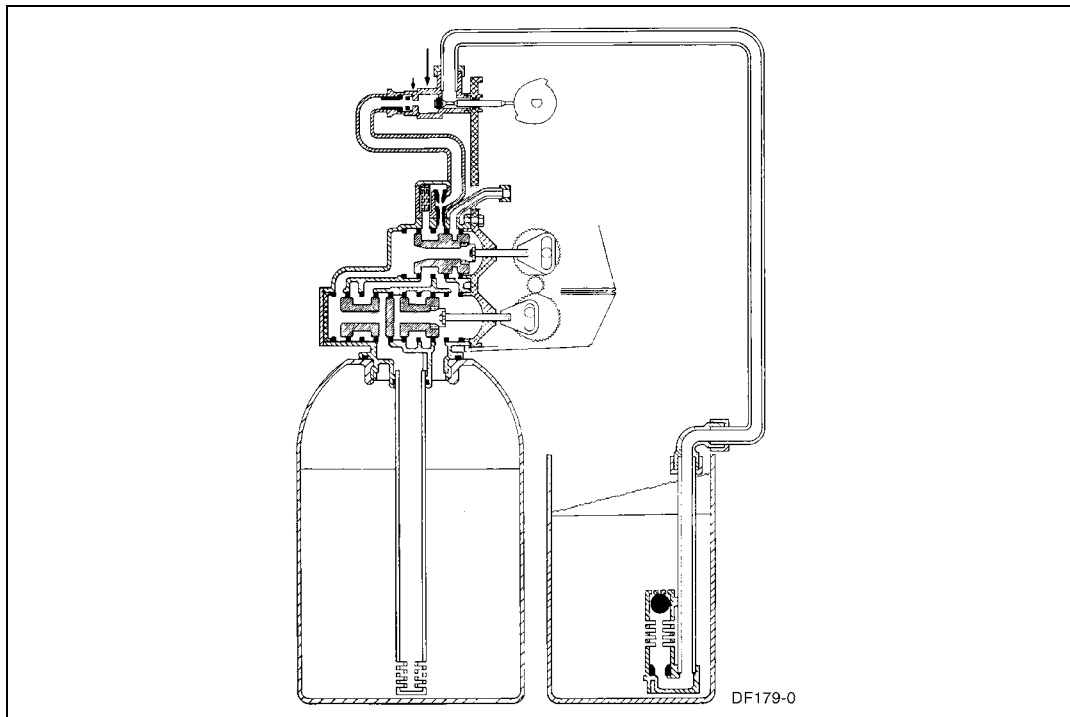

Figure 39: Tanks Switching, Meter Initiated Regeneration



# Model 9000/9100/9500

## Backwash

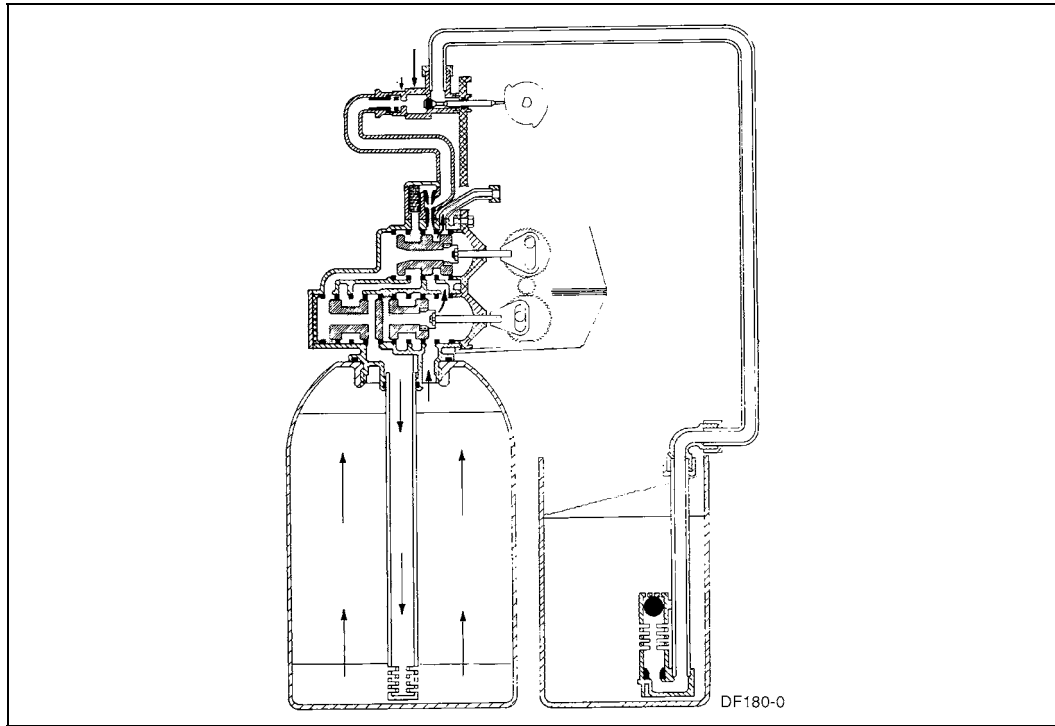

Figure 40: Backwash Position

## Brine Draw

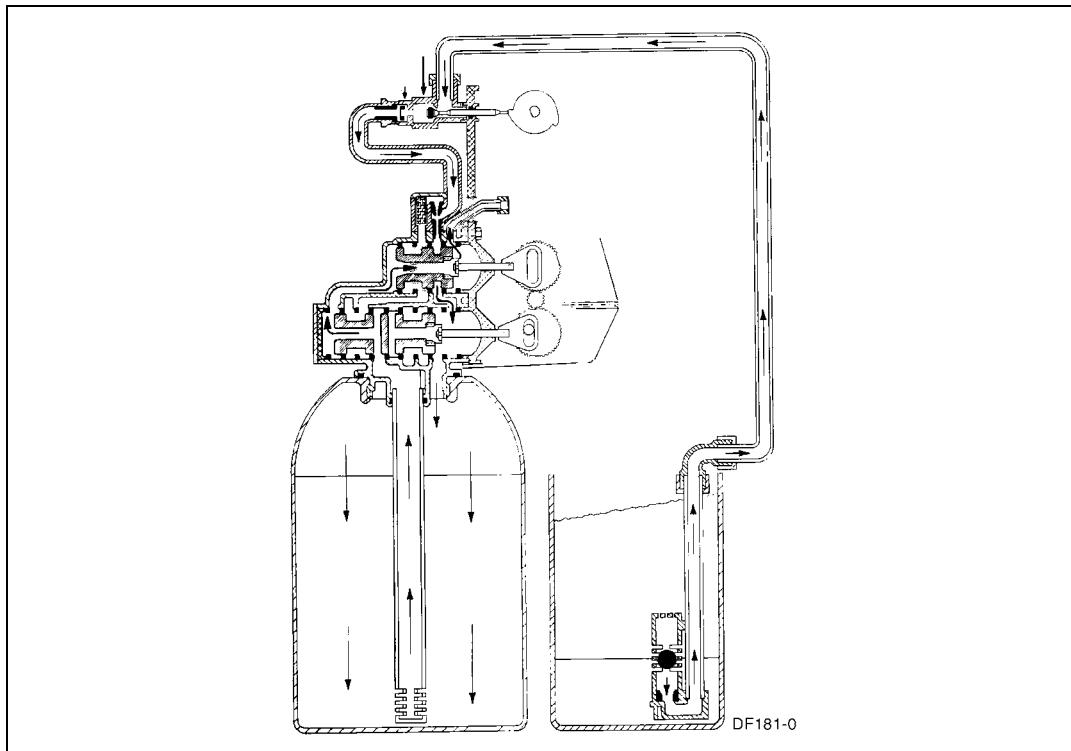

Figure 41: Brine Draw

# Model 9000/9100/9500

## Slow Rinse

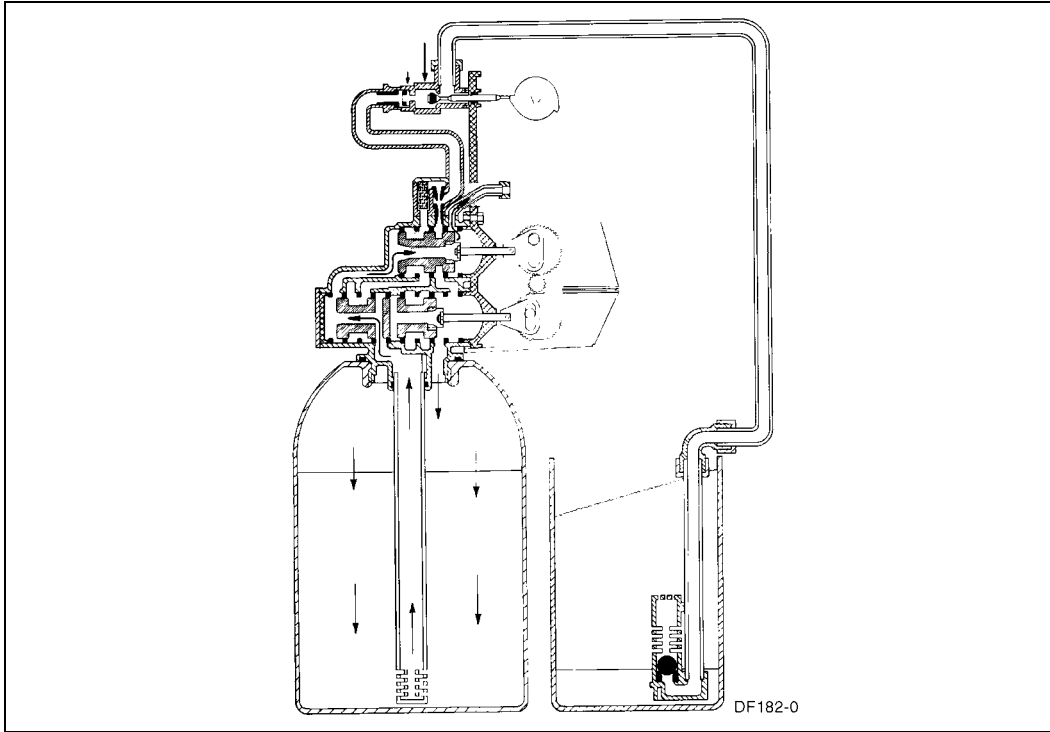

Figure 42: Slow Rinse

## Rapid Rinse

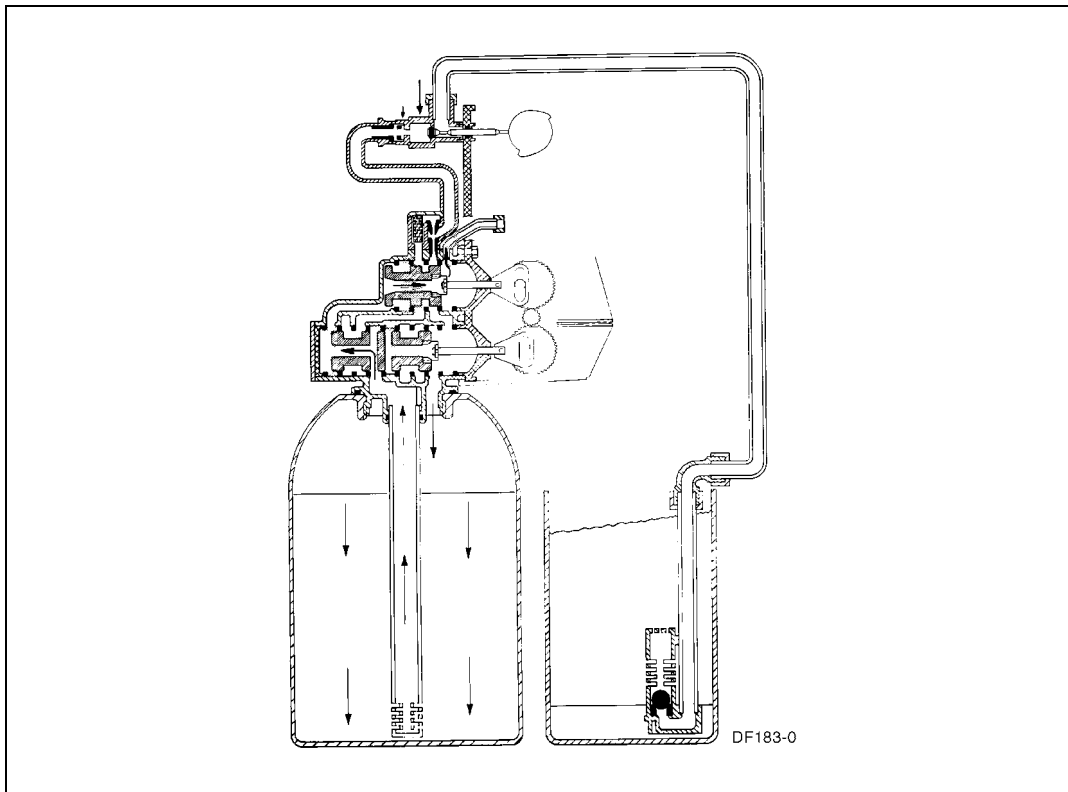

Figure 43: Rapid Rinse

# Model 9000/9100/9500

## Brine Tank Fill Position

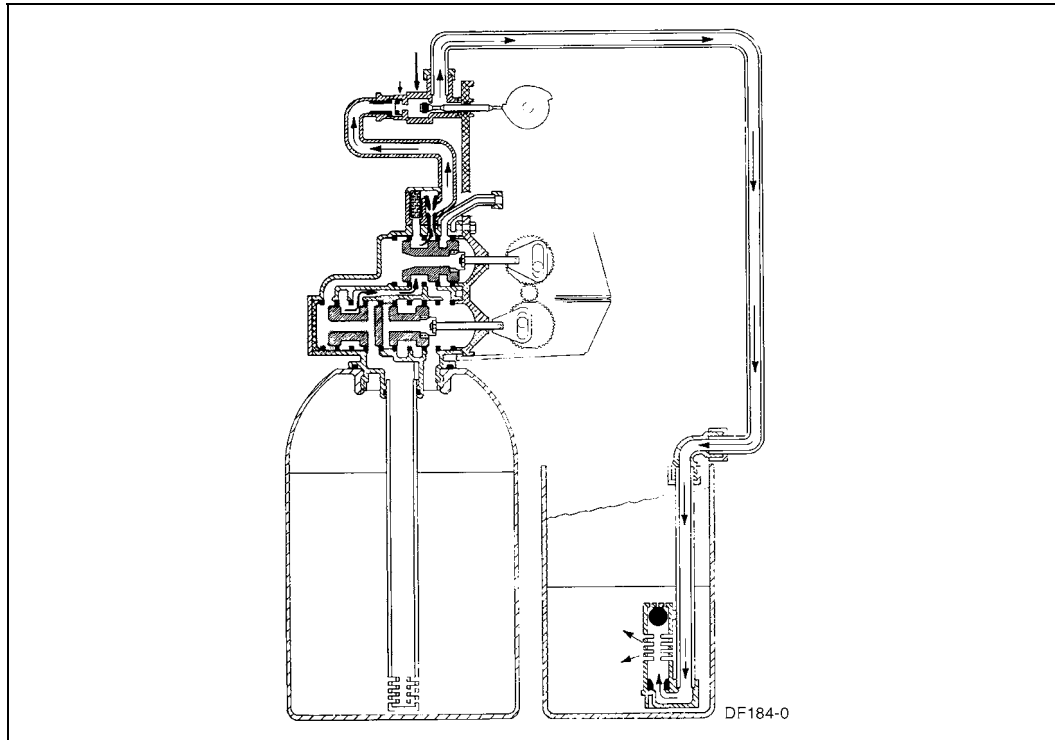

Figure 44: Brine Tank Fill Position

## In Service, Tanks Switched

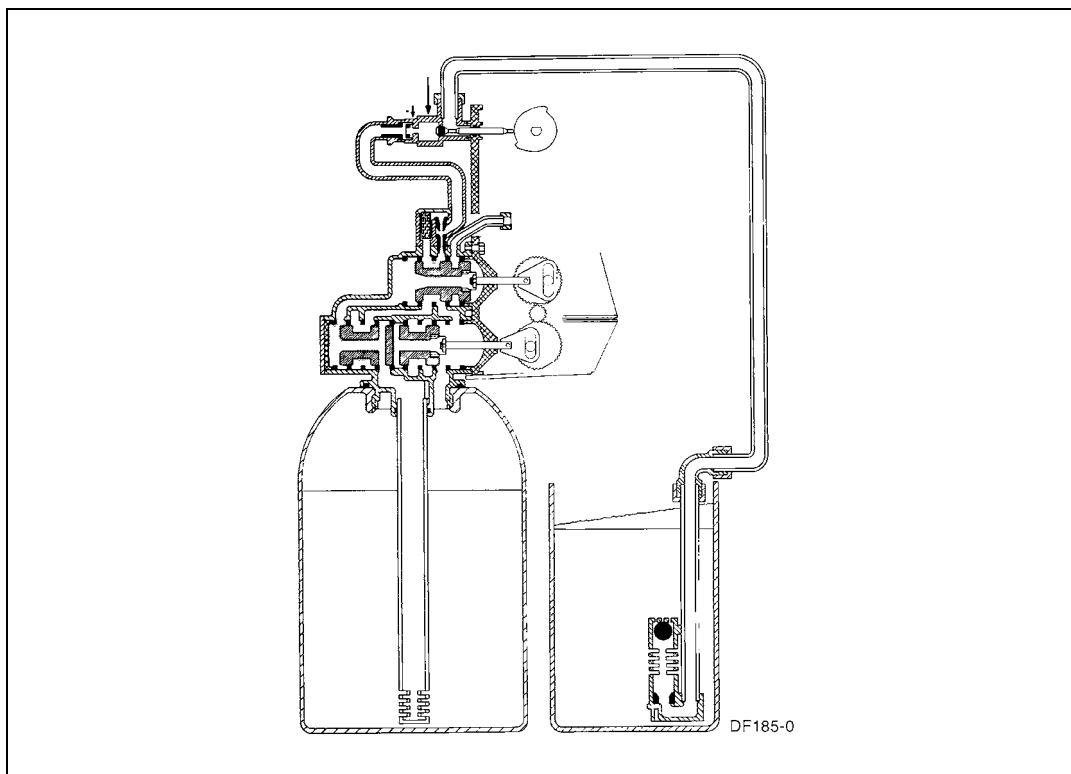

Figure 45: In Service, Tanks Switched

# Model 9000/9100/9500

## Troubleshooting

PROBLEM	CAUSE	CORRECTION
1. Softener fails to regenerate.	A. Electrical service to unit has been interrupted. B. Timer is defective.	A. Assure permanent electrical service (check fuse, plug, pull chain or switch). B. Replace timer.
2. Hard water.	A. Bypass valve is open. B. No salt in brine tank. C. Injector screen plugged. D. Insufficient water flowing into brine tank. E. Hot water tank hardness. F. Leak at distributor tube. G. Internal valve leak.	A. Close bypass valve. B. Add Salt to brine tank and maintain salt level above water level. C. Clean injector screen. D. Check brine tank fill time and clean brine line flow control if plugged. E. Repeated flushing of the hot water tank is required. F. Make sure distributor tube is not cracked. Check O-Ring and tube pilot. D. Replace seals and spacers and/or piston.
3. Unit used too much salt.	A. Improper salt setting. B. Excessive water in brine tank.	A. Check salt usage and salt setting. B. See Problem No. 7.
4. Loss of water pressure.	A. Iron buildup in line to water conditioner. B. Iron buildup in water conditioner. C. Inlet of control plugged due to foreign material broken loose from pipe by recent work done on plumbing system.	A. Clean line to water conditioner. B. Clean control and add mineral cleaner to mineral bed. Increase frequency of regeneration and/or backwash time. C. Remove pistons and clean control.
5. Loss of mineral through drain line.	A. Air in water system. B. Drain line flow control too large.	A. Assure that well system has proper air eliminator control. Check for dry well condition. B. Check to ensure drain line flow control is sized properly for your mineral tank.
6. Iron in conditioned water.	A. Fouled mineral bed.	A. Check backwash, brine draw and brine tank fill. Increase frequency of regeneration.
7. Excessive water in brine tank.	A. Plugged drain line flow control. B. Plugged injector system. C. Timer not cycling. D. Foreign material in brine valve. E. Foreign material in brine line flow control. F. Power loss during brine fill.	A. Check flow control. B. Clean injector and screen. C. Replace timer. D. Replace brine valve seat and clean valve. E. Clean brine line flow control. F. Check power source.

# Model 9000/9100/9500

PROBLEM	CAUSE	CORRECTION
8. Softener fails to draw brine.	<ul style="list-style-type: none"> <li>A. Drain line flow control is plugged.</li> <li>B. Injector is plugged.</li> <li>C. Injector screen plugged.</li> <li>D. Line pressure is too low.</li> <li>E. Internal Control Leak</li> </ul>	<ul style="list-style-type: none"> <li>A. Clean drain line flow control.</li> <li>B. Clean injector.</li> <li>C. Clean screen.</li> <li>D. Increase line pressure to 25 psi min.</li> <li>E. Change seals, spacers and piston assembly.</li> </ul>
9. Control cycles continuously.	<ul style="list-style-type: none"> <li>A. Broken or shorted switch.</li> </ul>	<ul style="list-style-type: none"> <li>A. Determine if switch or timer is faulty and replace it, or replace complete power head.</li> </ul>
10. Drain flows continuously.	<ul style="list-style-type: none"> <li>A. Valve is not programming correctly.</li> <li>B. Foreign material in control.</li> <li>C. Internal control leak.</li> </ul>	<ul style="list-style-type: none"> <li>A. Check timer program and positioning of control. Replace power head assembly if not positioning properly.</li> <li>B. Remove power head assembly and inspect bore, remove foreign material and check control in various regeneration positions.</li> <li>C. Replace seals and piston assembly.</li> </ul>

## General Service Hints

### Problem: Softener delivers hard water

PROBLEM	CAUSE	CORRECTION
Softener delivers hard water.	<p>Reserve capacity has been exceeded.</p> <p>Program wheel is not rotating with meter output.</p> <p>Meter is not measuring flow.</p>	<p>Check salt dosage requirements and reset program wheel to provide additional reserve.</p> <p>Pull cable out of meter cover and rotate manually. Program wheel must move without binding and cycle actuator must start the cycle before the clutch releases.</p> <p>Check output by observing rotation of small gear on front of timer</p> <p>(Note: Program wheel must not be against regeneration stop for this check)</p> <p>Each tooth is approximately 75 gallons on 1-1/2" installations. If not performing properly, replace meter.</p>

# Model 9000/9100/9500

## Mechanical Timer Valve Wiring

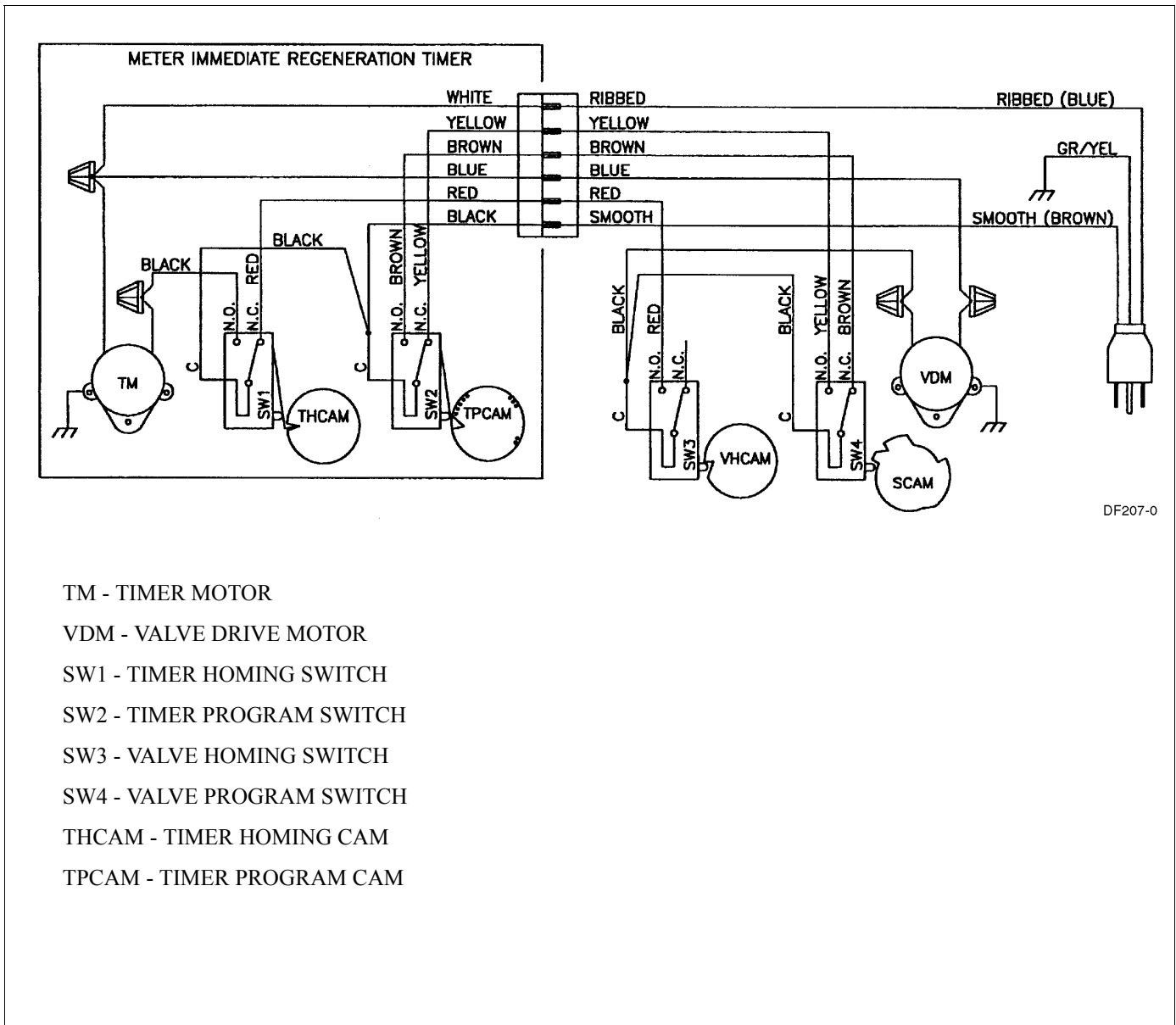

Figure 46

# Model 9000/9100/9500

## ET Timer Valve Wiring

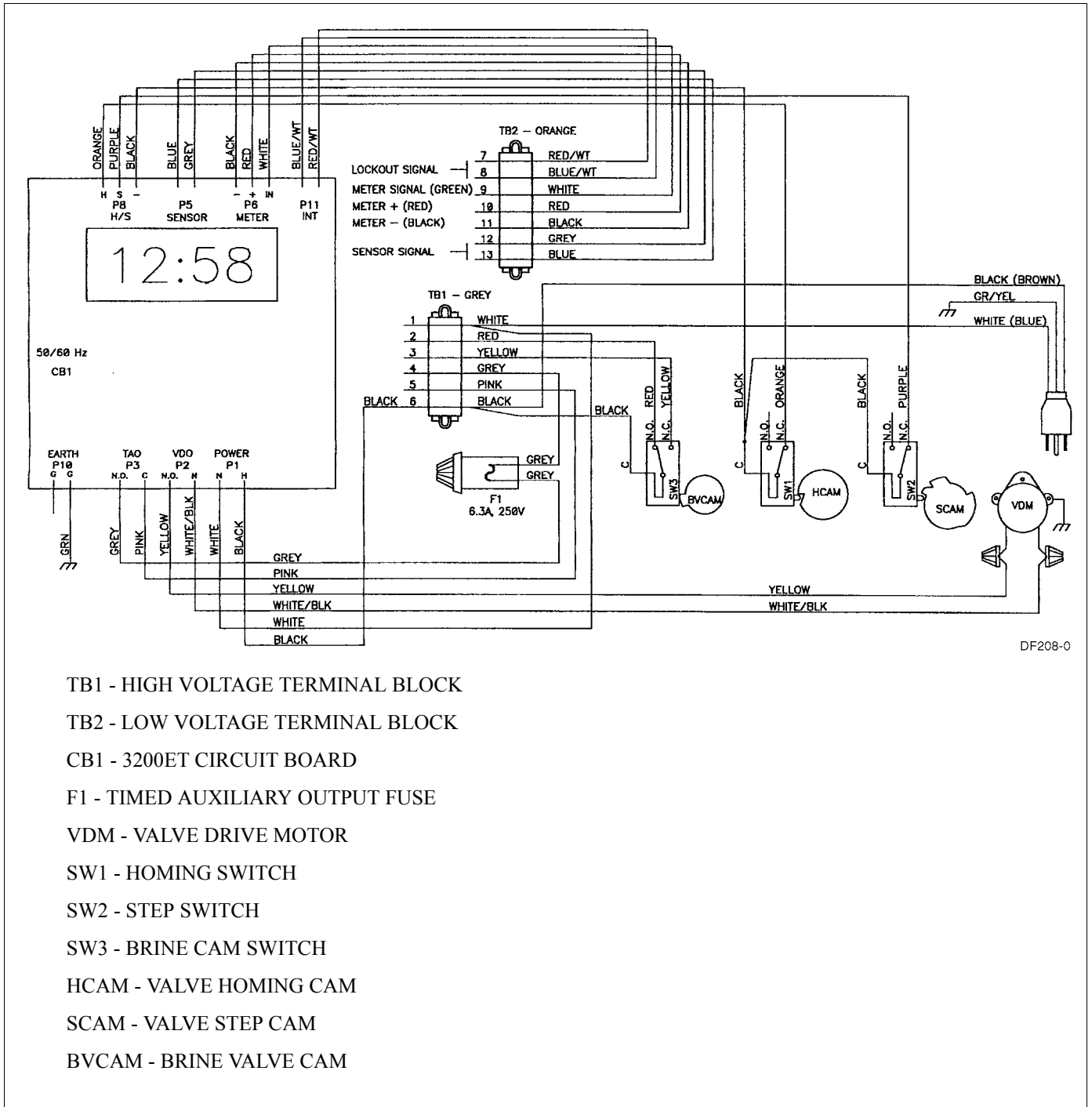
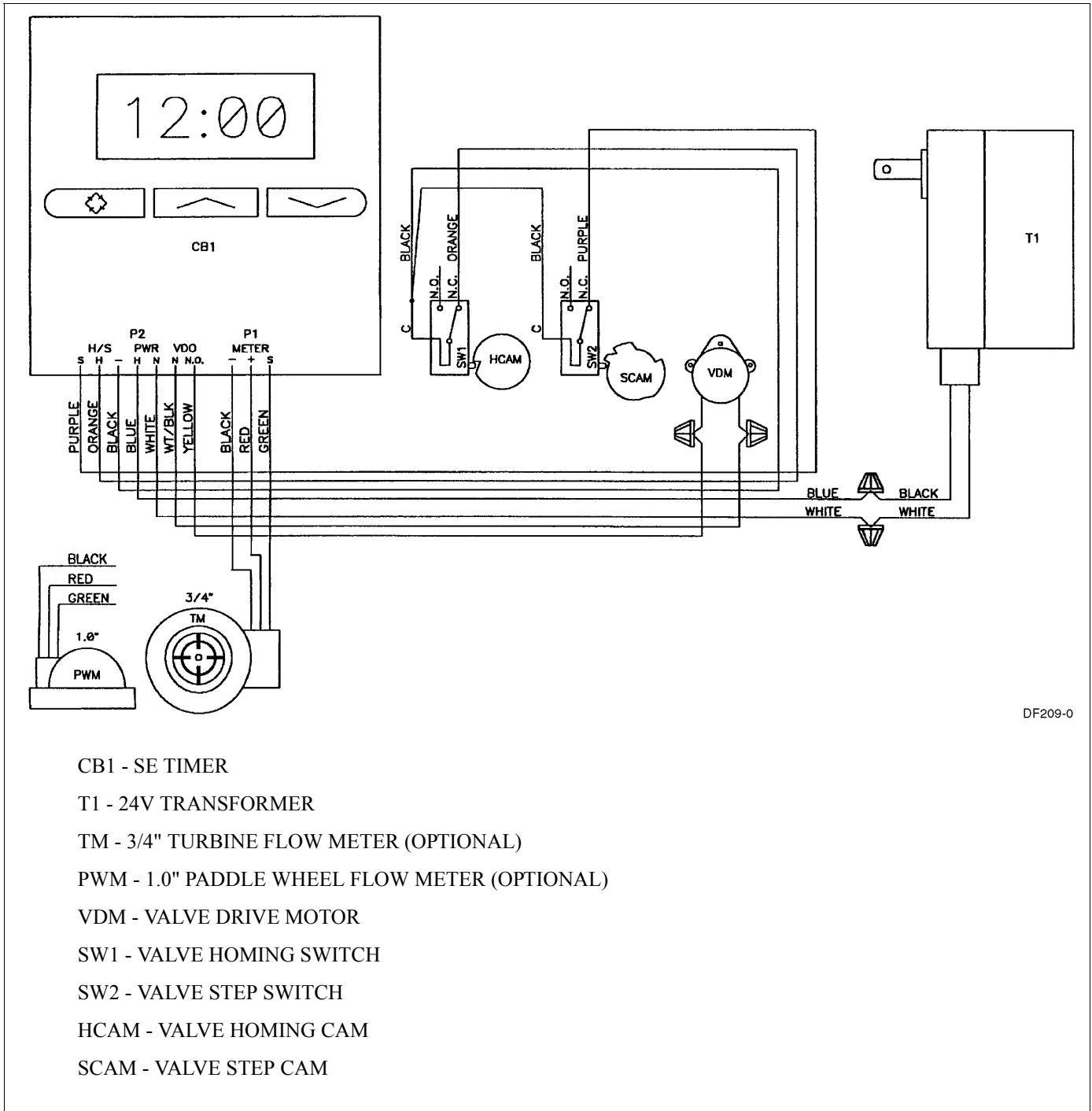

Figure 47

Twin Unit Meter/Timeclock/Sensor Regeneration

# Model 9000/9100/9500

## SE Timer Valve Wiring



DF209-0

Figure 48



# Model 9000/9100/9500

## 9000 Control Dimensions

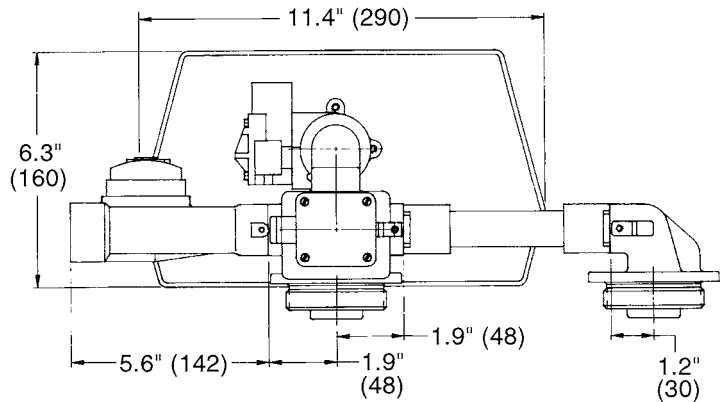
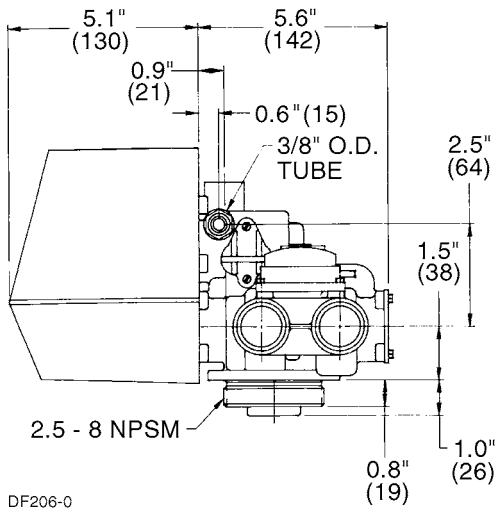
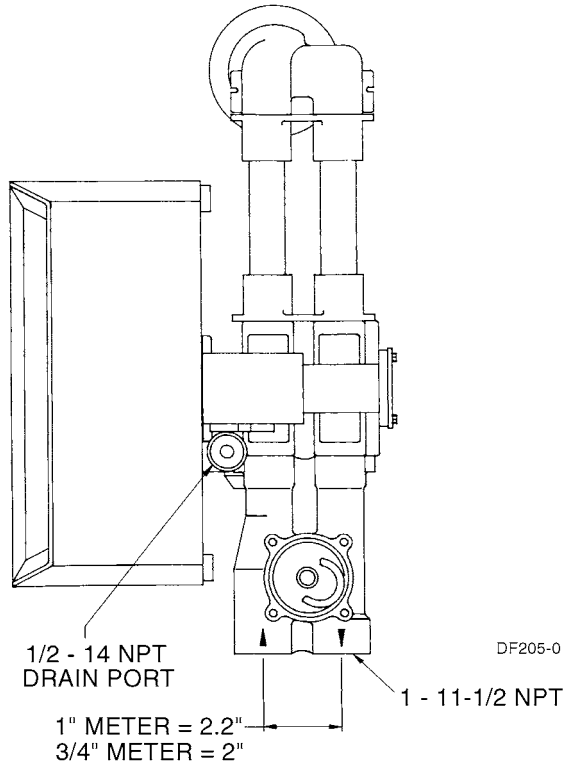

Figure 49

# Model 9000/9100/9500

## 9100 Control Dimensions

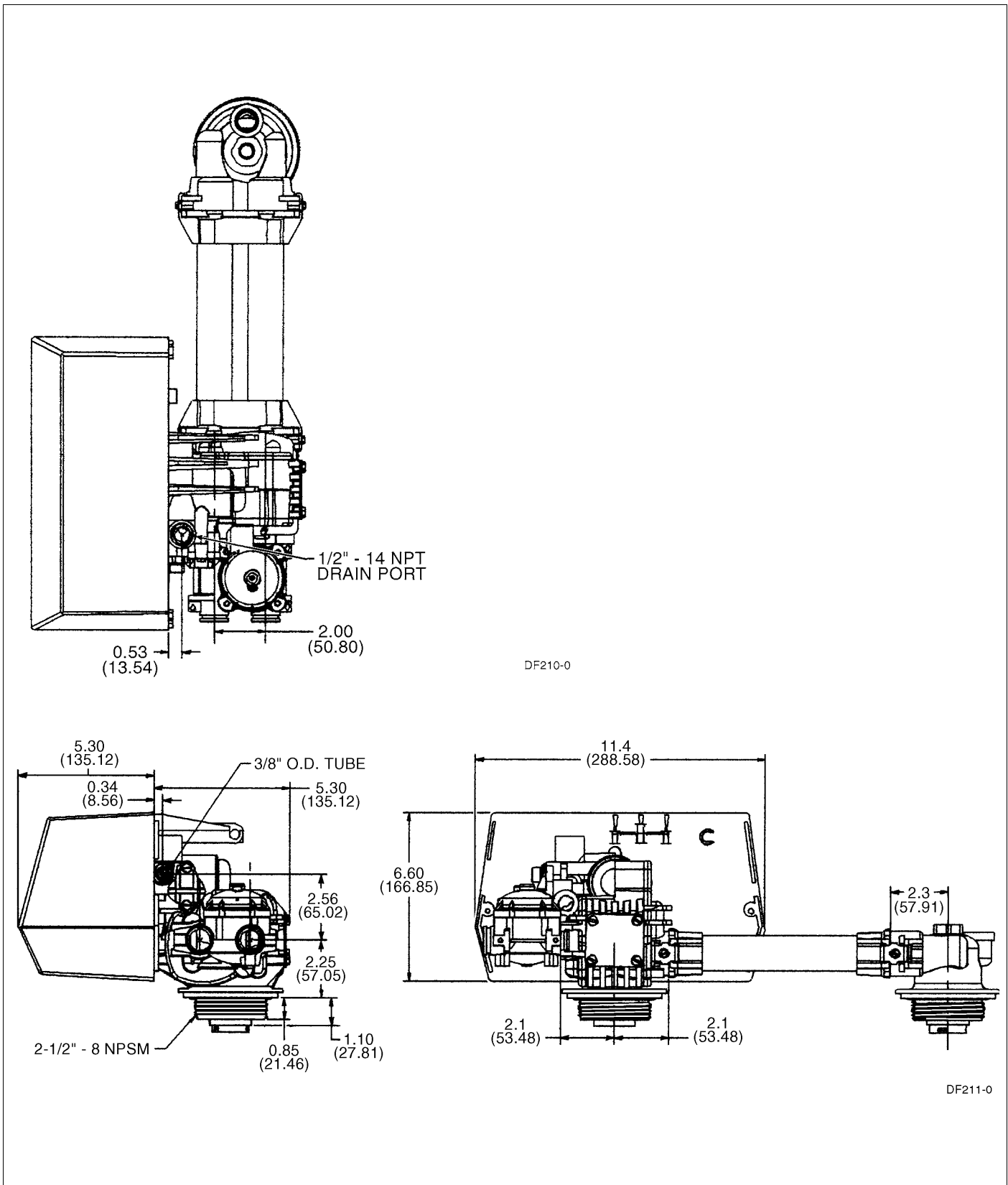

Figure 50

# Model 9000/9100/9500

## 9500 Control Dimensions

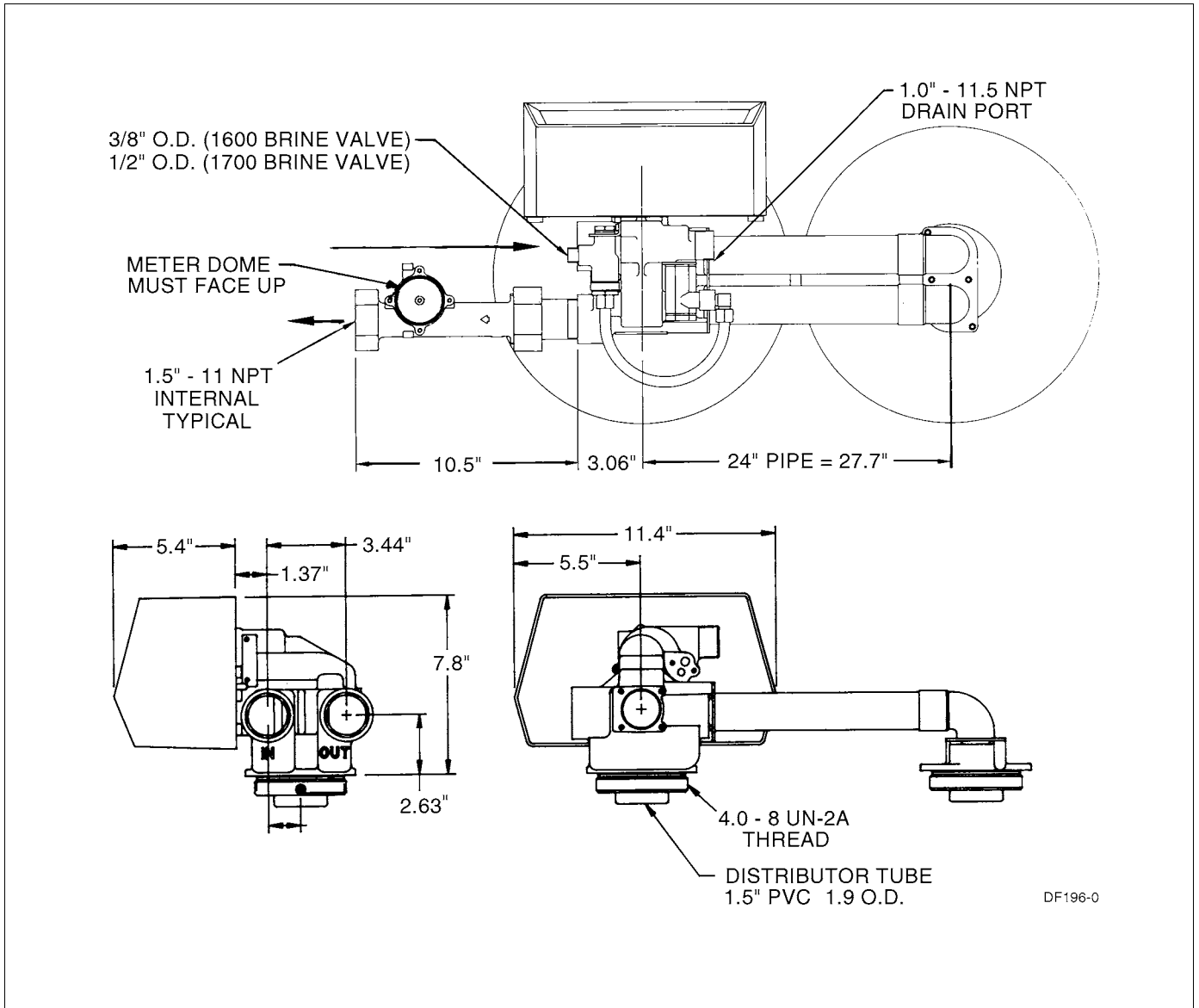

Figure 51

# Model 9000/9100/9500

## Meter Flow Data

### 9000

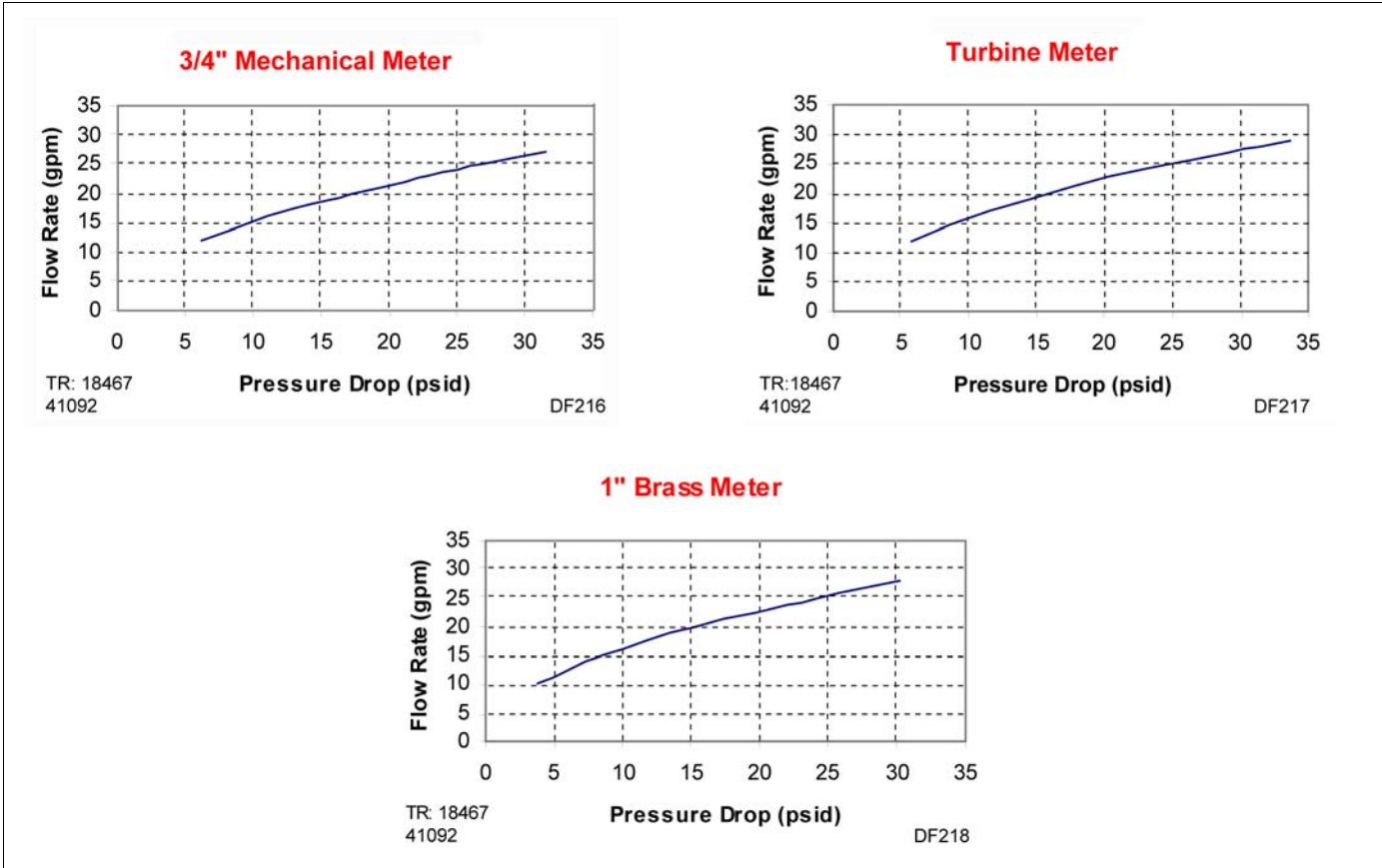

Figure 52: 9000 Meter Flow Data

# Model 9000/9100/9500

## 9100

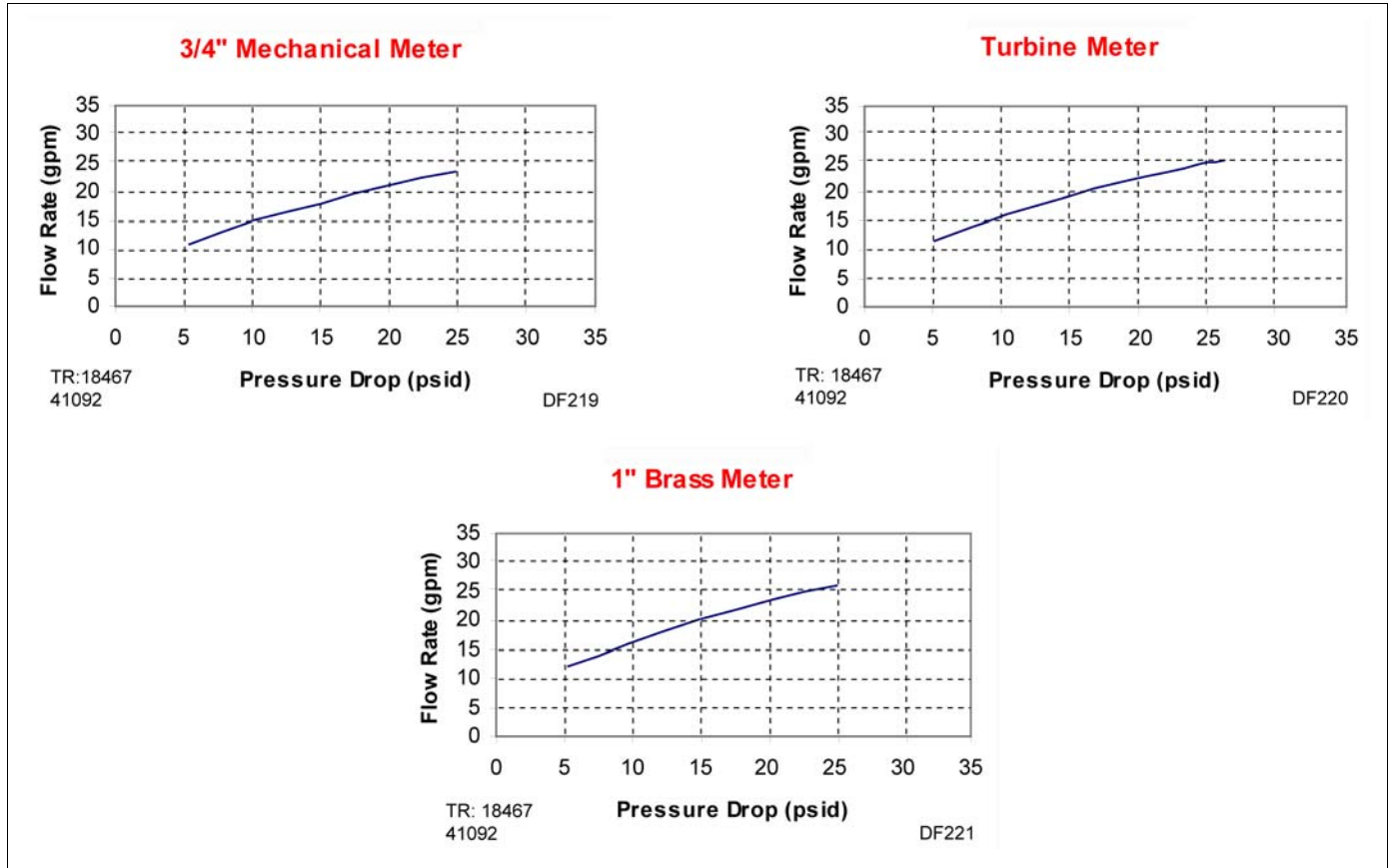

Figure 53: 9100 Meter Flow Data

## 9500

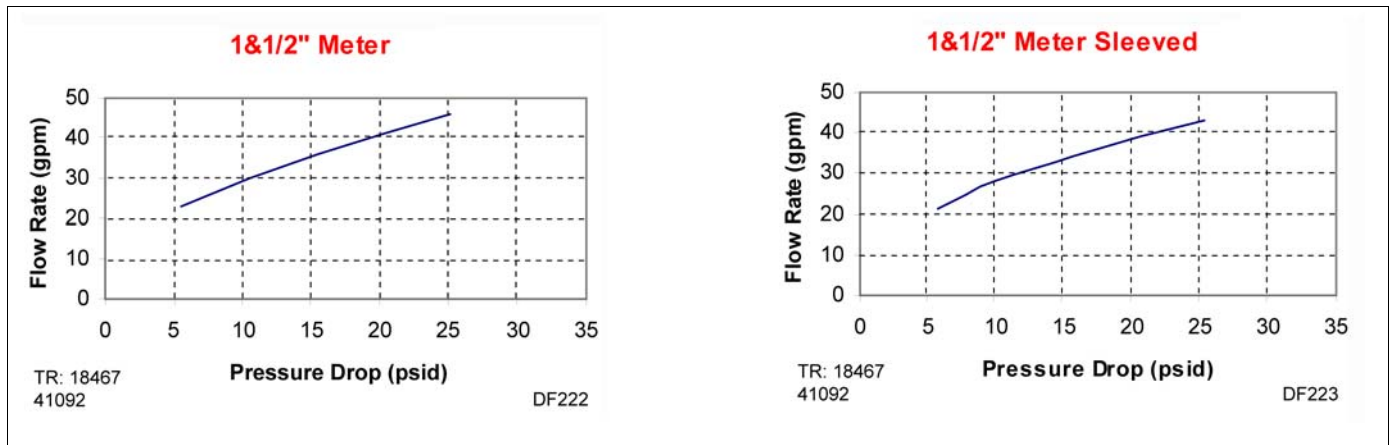

Figure 54: 9500 Meter Flow Data

# Model 9000/9100/9500

## Injector Flow Data

9000/9100

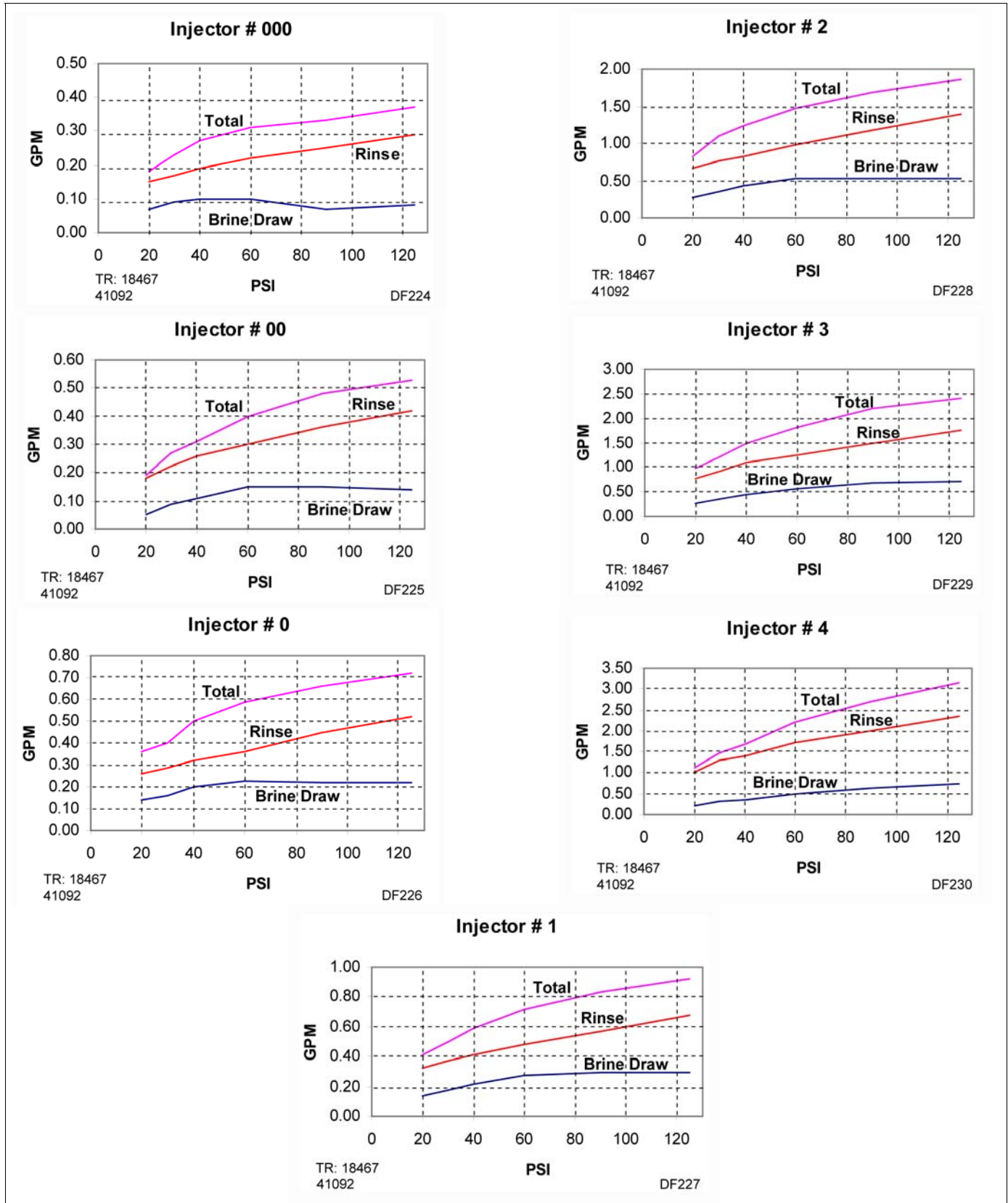

Figure 55: 9000/9100—1600 Series Injectors

# Model 9000/9100/9500

9500

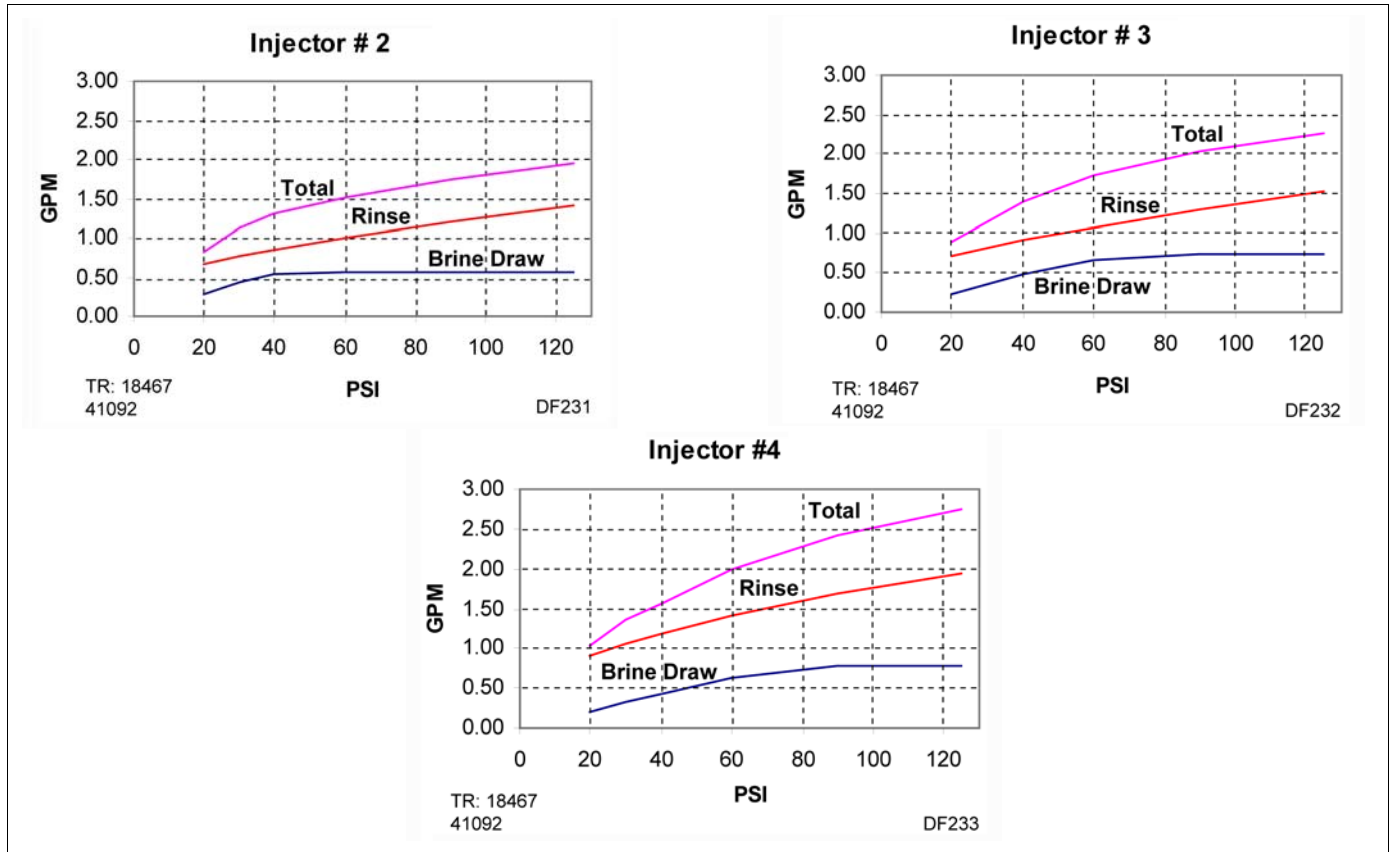

Figure 56: 9500–1600 Series Injectors

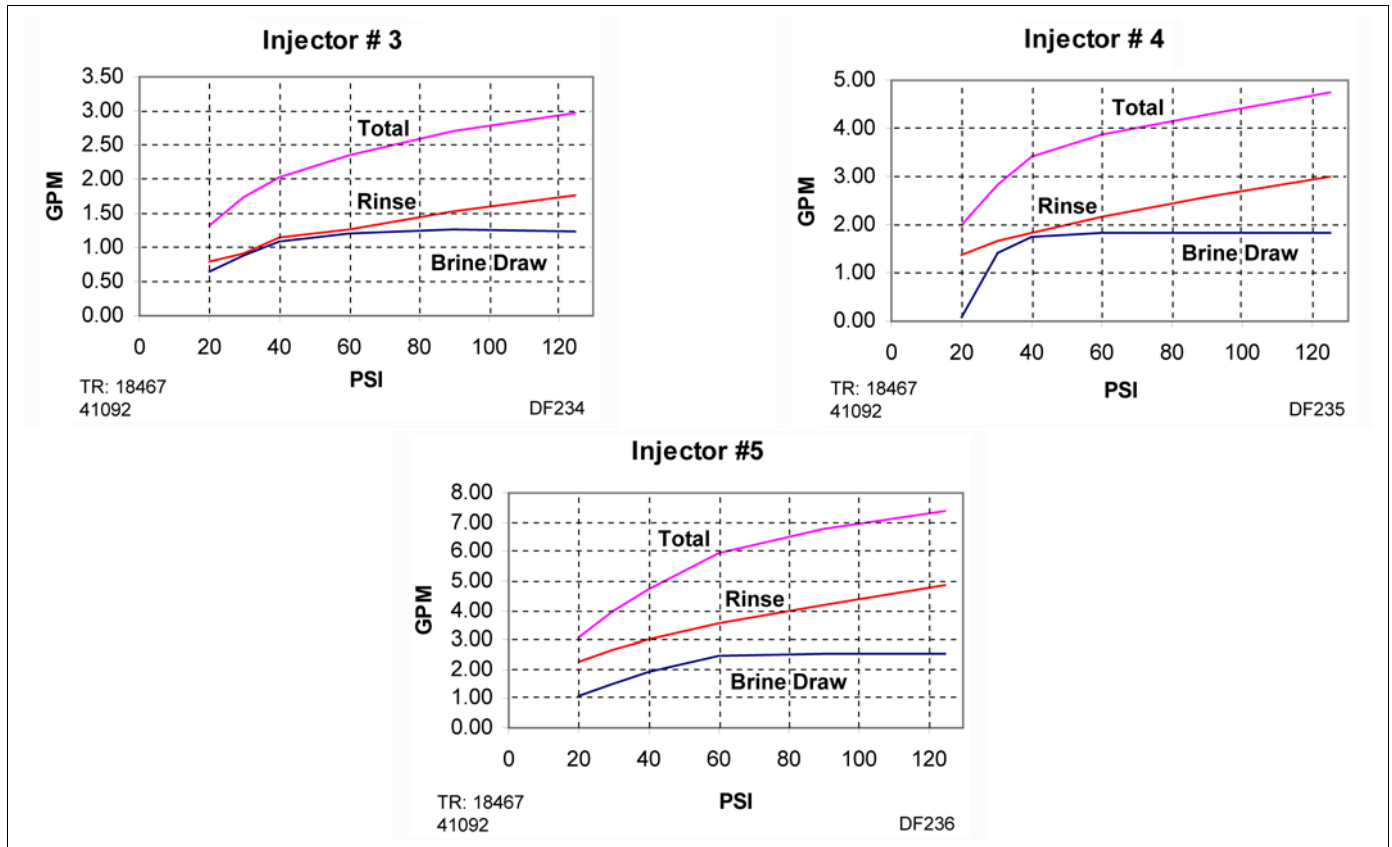

Figure 57: 9500–1700 Series Injectors

