

# Residential Gas and Electric Water Heaters

## MODELS COVERED

Residential Gas Water Heaters that are atmospherically vented and use a thermocouple as their electrical source.

Residential Electric Water Heaters having one or two heating elements and common wiring configurations for these models.



# RESIDENTIAL GAS AND ELECTRIC WATER HEATER SERVICE HANDBOOK

---

## TABLE OF CONTENTS

	Page		Page
<b>Introduction</b>		<b>Residential Electric Water Heaters</b>	
Terms .....	1	Installation.....	26
Tools .....	2	Standard Illustrations.....	27
<b>Residential Gas Water Heaters</b>		Guidelines.....	28
General Information .....	3	Elements.....	29
Installation.....	5	Thermostat.....	30
<b>Operations and Servicing</b>		C-2 Circuit.....	31
Control.....	6	C-2 Sequence of Operation.....	32
Burner .....	7	A-6 Circuit.....	33
Normal Operations.....	7	A-6 Sequence of Operation.....	34
Temperature.....	8	A-7 Circuit.....	35
Gas.....	8	A-7 Sequence of Operation.....	36
Water Flow .....	9	A-7 – wiring – Post 1995.....	37
Service .....	10	A-7 - Sequence of Operation .....	38
Procedures and Conditions.....	11	Certification and Approvals.....	39
Multiple Heater Piping.....	14	Unbalanced 3 phase.....	40
Exhaust Venting Notes.....	15	C-2 Ohms Check.....	41
<b>Flammable Vapor Ignition Design</b> .....	15	C-2 Ohms Check.....	42
Lint, Dust & Oil Screen.....	16	C2 No Hot Water.....	43
Flame Arrestor.....	17	C-2 Grounded Element Check.....	44
Thermal Cut Off Switch.....	18	A-6 Ohms Check – No Hot Water.....	45
Pilot Burner Assembly.....	19	A-6 No Hot Water Voltage Check.....	46
Sealed Combustion Chamber.....	20	A-6 Lack of Hot Water Voltage Ck....	47
Piezo Igniter.....	21	A-6 Grounded Element Test.....	48
Miscellaneous .....	22	A-7 Service.....	49
FVIR Service Tip.....	23-25	A-7 Ohms Test.....	50
		A-7 Voltage Checks.....	51
		A-7 Lack of Hot .....	52
		A-7 Grounded Element Test.....	53-54
		Miscellaneous and Ohms Table.....	55
		<b>Technical Bulletins</b> .....	<b>56-69</b>

## RESIDENTIAL GAS AND ELECTRIC SERVICE HANDBOOK INTRODUCTION

This service handbook is designed to aid in servicing and troubleshooting A.O. Smith Residential Gas and Electric water heaters in the field. No duplication or reproduction of this book may be made without the express written authorization of the A.O. Smith Water Products Company.

The following text and illustrations will provide you with a step-by-step procedure to verify proper installation, operation, and troubleshooting procedures. Additional quick reference data is included to assist you in servicing this product.

# RESIDENTIAL GAS AND ELECTRIC WATER HEATER SERVICE HANDBOOK

---

The information contained in this handbook is designed to answer commonly faced situations encountered in the operation of the Residential Gas and Electric product line and is not meant to be all-inclusive. If you are experiencing a problem not covered in this handbook, please contact the A.O. Smith Technical Information Center at 1-800-527-1953 or your local A.O. Smith Water Products Company representative for further assistance. Additional information is also available on the web site [www.aosmithwaterheaters.com](http://www.aosmithwaterheaters.com). This handbook is intended for use by licensed plumbing professionals and reference should be made to the instructional manual accompanying the product. This handbook contains supplemental information to the Residential Gas and Electric instructional manual.

## Qualifications

### Tools Required:

For servicing **gas** models:

- Cross top screw driver
- 3/8, 7/16, 3/4 inch open end wrenches
- 3/16 inch Allen wrench
- 11/16 inch – 6 point – socket – for anode removal
- set of marked drill bits
- electrical multimeter
- gas pressure gauge or monometer
- water pressure gauge
- thermometer
- tubing cutter if pilot tube is to be replaced
- hose – to drain tank
- container – to measure gallons per minute flow

For servicing **electric** models:

- 1 1/16 inch – 6 point – socket (for anode removal)
- 1 1/2 inch deep socket – to remove an element
- electrical multimeter
- water pressure gauge
- thermometer
- hose – to drain tank
- container – to measure gallons per minute flow

**Rev 1 adds Technical Bulletins**

**Rev 2 corrects illustration errors**

**Rev 3 adds FVIR (C3) Technology product information**

**2005 printing – revised cover**

**Rev 4 Added FVIR cleaning instructions**

# RESIDENTIAL GAS AND ELECTRIC WATER HEATER SERVICE HANDBOOK

---

## GENERAL SECTION

### MISCELLANEOUS INFORMATION

**Draw efficiency** is the quantity of hot water available to the consumer before the outlet water temperature decreases 25 degrees F. A 40 gallon water heater will typically provide 70% (28 gallons) of this “usable” hot water. The burner or elements are allowed to operate during this test. Incoming, cold water mixes the remaining stored water below this 25 degree limitation.

**Energy Factor** is an indicator of the combined thermal efficiency and standby efficiency of a water heater. The higher the energy factor, the more efficient the water heater will be.

**Recovery rate** is the amount of water that is heated to a set temperature, per hour. An example might be that a water heater has a recovery rate of 30 gallons of water per hour at 80 degree F. (Fahrenheit) temperature rise.

**“R” Value** is a measure of the resistance of a substance to heat flow.

**Thermal efficiency** is approximately the amount of generated BTU (British Thermal Units), which enters the water. A percentage of the total BTU passes out through the vent piping.

**Temperature rise** is the increase in the temperature from its coldest “inlet” water temperature to the desired hot (outlet) setting. Typically this is assumed to be 40 degrees entering water, 120 degrees desired stored water or 80 degrees “temperature rise.”

**Standby efficiency** – the water heater’s ability to contain heat in the tank. A minimum of tank water heat loss per hour is desired.

Sample:  $\frac{\text{temperature change}}{\text{“R” value}} = \text{Btu/h loss/ square foot of tank surface}$

**Water cannot** (for all practical purposes) be compressed.

**Water expands** when it is heated.

**Water Hammer** – is a concussion of moving water against the sides of a containing pipe or vessel on a sudden stoppage of flow.

EX: 1/2 “copper pipe, 5GPM flow (7.2ft/sec.) – stop. Pressure rise of approximately 412 PSI.  
3/4” copper pipe, 5GPM flow (3.3ft/sec) – stop. Pressure rise of approximately 188 PSI

**Minerals and gases** will separate from water as temperature increases.

### **Formulas:**

**BTU (British Thermal Unit)** is the heat required to raise 1 pound of water 1°F

1 BTU = 252 cal = 0.252 kcal

1 cal = 4.187 Joules

BTU X 1.055 = Kilo Joules

BTU divided by 3,413 = Kilowatts

**To convert** from Fahrenheit to Centigrade: (° F – 32) times 5/9, or .556, equals degrees C.

## RESIDENTIAL GAS AND ELECTRIC WATER HEATER SERVICE HANDBOOK

---

**One gallon** of (120° F, 49°C) water weighs approximately 8.25 pounds.

Pounds X .45359 = Kilogram

Gallons X 3.7854 = Liters

**% of Hot** = (Mixed Temp. – Cold) divided by (Hot Temp. – Cold)

**General Section – continued**

**% Thermal Efficiency** = (GPH X 8.25 X Temp. Rise X 1.0) divided by BTU/H Input

**BTU Output** = GPH X 8.25 X Temp. Rise X 1.0

**GPH** = (BTU/H Input X % Eff.) divided by (Temp. Rise X 8.25)

**One cubic foot** of Natural Gas contains about 1000 BTU of heat.

**One “therm”** is equal to 100,000 BTU

**One cubic foot** of Propane Gas contains about 2500 BTU of heat.

**One gallon** of Propane gas contains about 91,250 BTU of heat.

**One pound** of Propane gas contains about 21,600 BTU of heat.

One pound of **gas pressure** is equal to 27.7 inches water column pressure

Inches of Water Column X .036091 = PSI

Inches of Water Column X .073483 = Inches of Mercury (Hg.)

**Centimeters** = Inches X 2.54

**MM** (millimeters) = Inches X 25.4

**Meters** = Inches X .0254

Doubling the diameter of a pipe will increase its flow capacity (approximately) 5.3 times.

**CONSTRUCTION:** **Tank** is constructed of steel.

The inside of the tank is constructed of a **glass lining** bonded to the steel. This prevents water to metal contact and rusting of the tank.

An **anode rod** will be installed within the tank. The hex-head plug end of the anode is visible on the top of the water heater. This metal rod offers secondary protection of the tank against corrosion where the application of glass is not possible (threaded tank openings). These areas will have small areas of water to metal contact.

All water heaters will contain at least **one thermostat** (to operate the heater) and **one high limit** (to prevent water temperatures approaching the “steam” level).

# RESIDENTIAL GAS AND ELECTRIC WATER HEATER SERVICE HANDBOOK

## INSTALLATION OF RESIDENTIAL GAS WATER HEATER

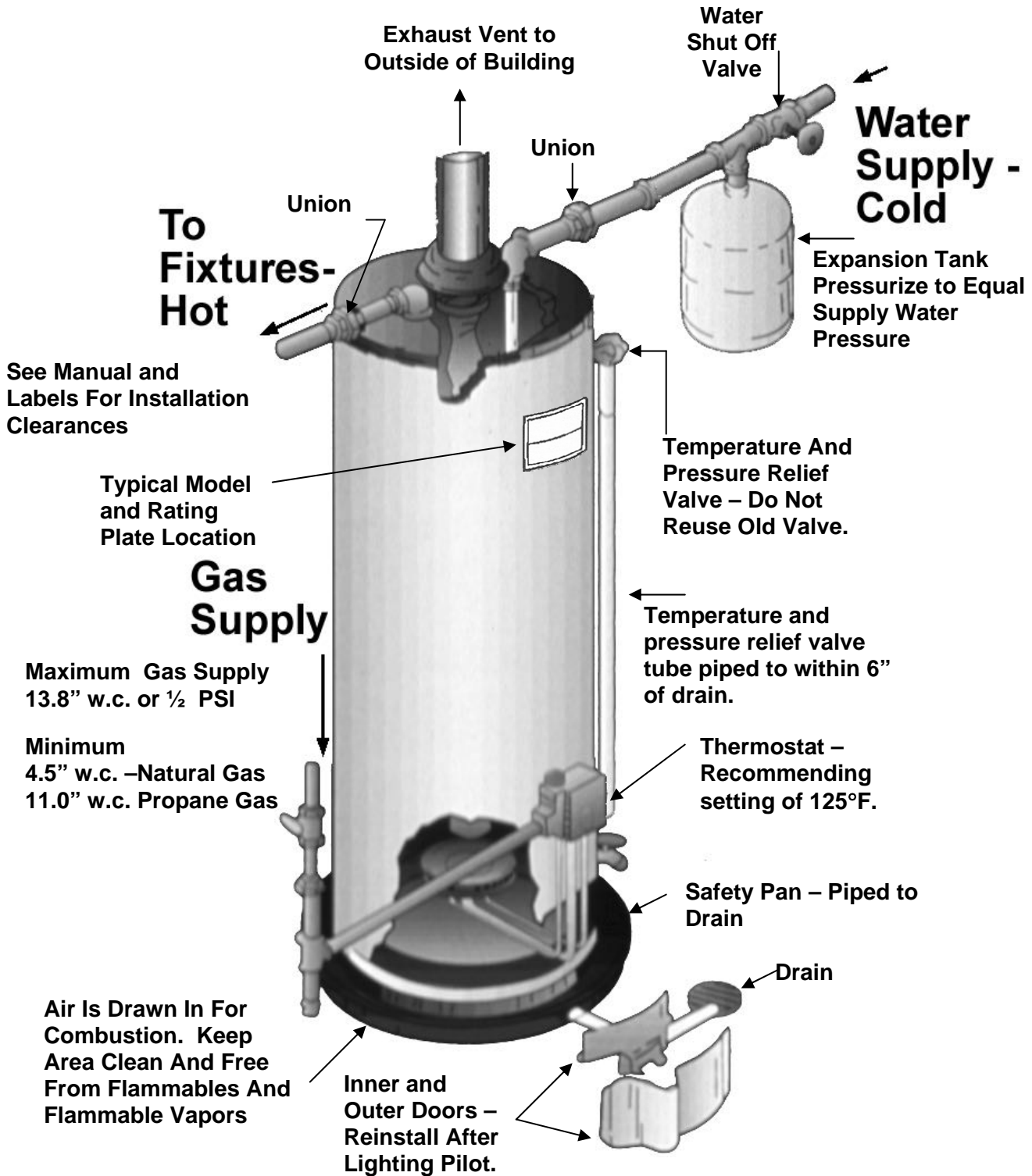

Installation Must Follow Local Codes and Instruction Manual Guidelines

# RESIDENTIAL GAS AND ELECTRIC WATER HEATER SERVICE HANDBOOK

## RESIDENTIAL GAS WATER HEATER SERVICE

This portion of this manual applies to the Operations and Servicing of Residential Gas, Tank Type, Water Heaters, which are vented atmospherically and use a thermocouple as their electrical source.

**Construction:** See also “General” section of this manual.

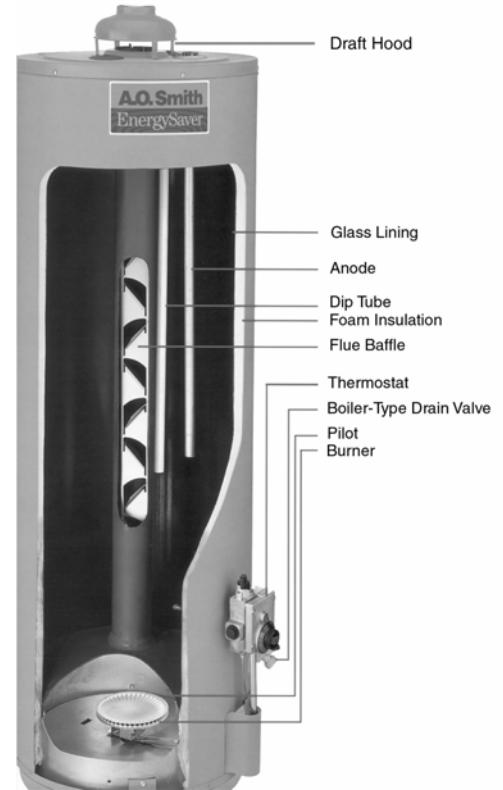
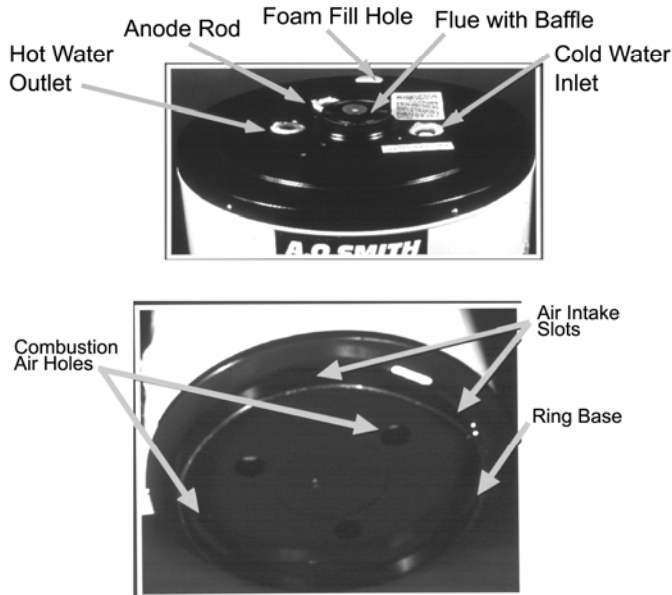

**Control:** There is one control on this style of water heater. The control has a main gas regulator, pilot gas regulator, on-off-pilot knob, controls water temperature, has a temperature adjustment knob, and a high water temperature limit safety.

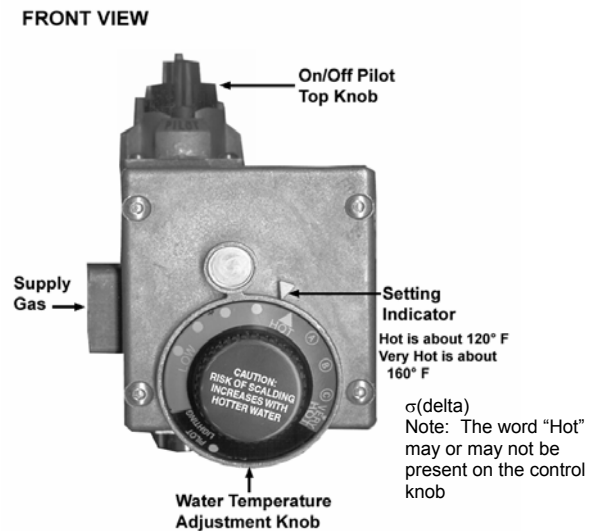
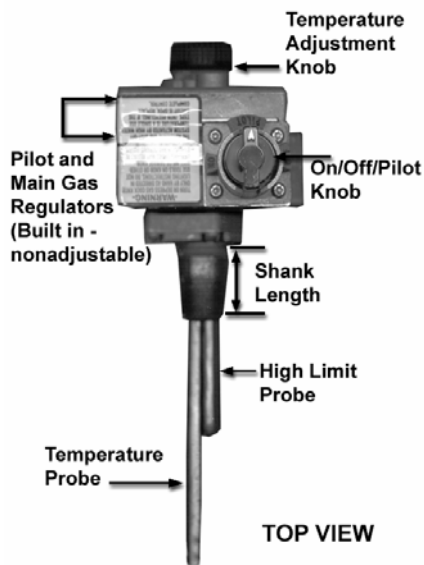

# RESIDENTIAL GAS AND ELECTRIC WATER HEATER SERVICE HANDBOOK

## Residential Gas – continued

**Burner:** The burner assembly consists of the main burner, main burner orifice, main burner gas supply tube, pilot burner, pilot burner orifice, pilot burner gas supply tube and thermocouple.

The pilot burner remains on once it is manually lit. When incoming cold water activates the thermostat, gas flows to the main burner. The pilot flame ignites this gas. The main flame burns until the tank reaches set temperature then the thermostat interrupts this main gas flow.

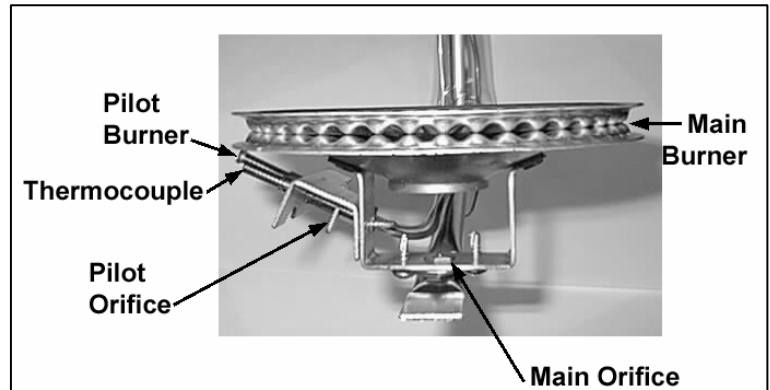
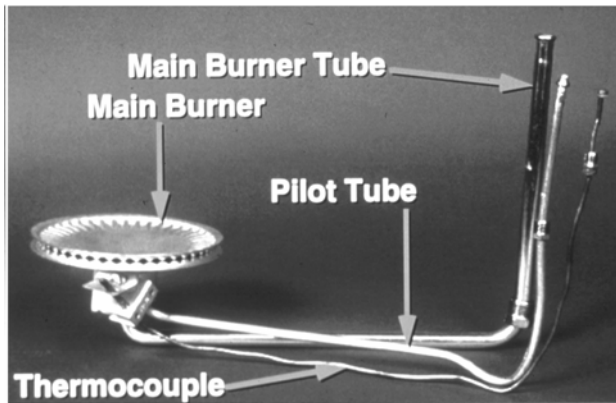

**AFTER HAVING CONFIRMED THAT THE WATER HEATER HAS BEEN INSTALLED PER THE INSTALLATION MANUAL INSTRUCTIONS:**

### Normal Operation

**Electrical:** The Pilot Flame heats the end of a thermocouple. As the thermocouple gets hotter, it generates a small (cannot be detected without an electrical meter) electrical current to the bottom of the control valve. This current powers the electromagnet and holds open the safety valve as long as the pilot flame is heating the thermocouple. DANGER! If the pilot is extinguished, it can take up to 180 seconds for the thermocouple to cool sufficiently to close the safety valve.

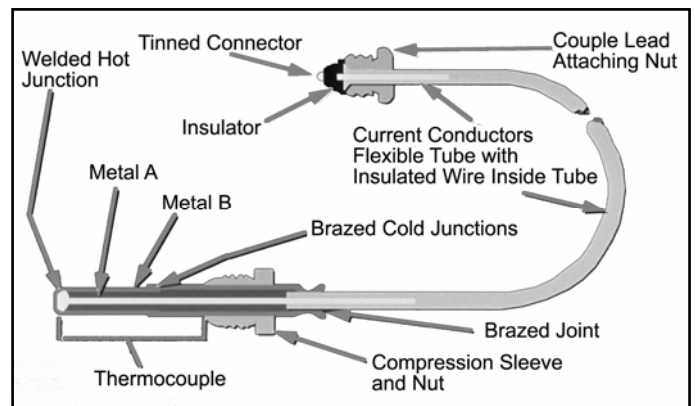
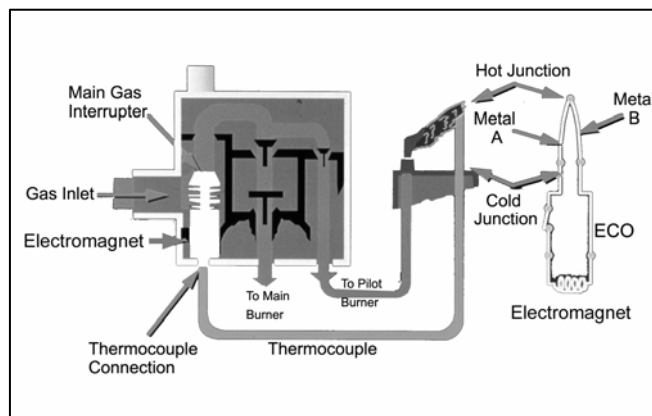

See also C3 technology product information beginning on page .



# RESIDENTIAL GAS AND ELECTRIC WATER HEATER SERVICE HANDBOOK

## Residential Gas – continued

**Temperature:** Two metal probes mounted onto the back of the control are immersed inside the tank water. One probe (the shorter) acts as a temperature high limit. If water gets excessively hot, a sensor within the probe opens, interrupts the small electrical current to the gas valve, and gas flow through the control is interrupted. If this safety sensor opens, the entire control must be replaced.

The longer probe contains a metal rod that expands and contracts as water temperature around the probe cools and heats. As the rod expands, it pushes against a lever actuated gas valve. If the regulator is pushed sufficiently, gas flow is interrupted to the main burner. Adjusting the temperature dial changes the distance the rod must expand or contract to open or close the gas valve.

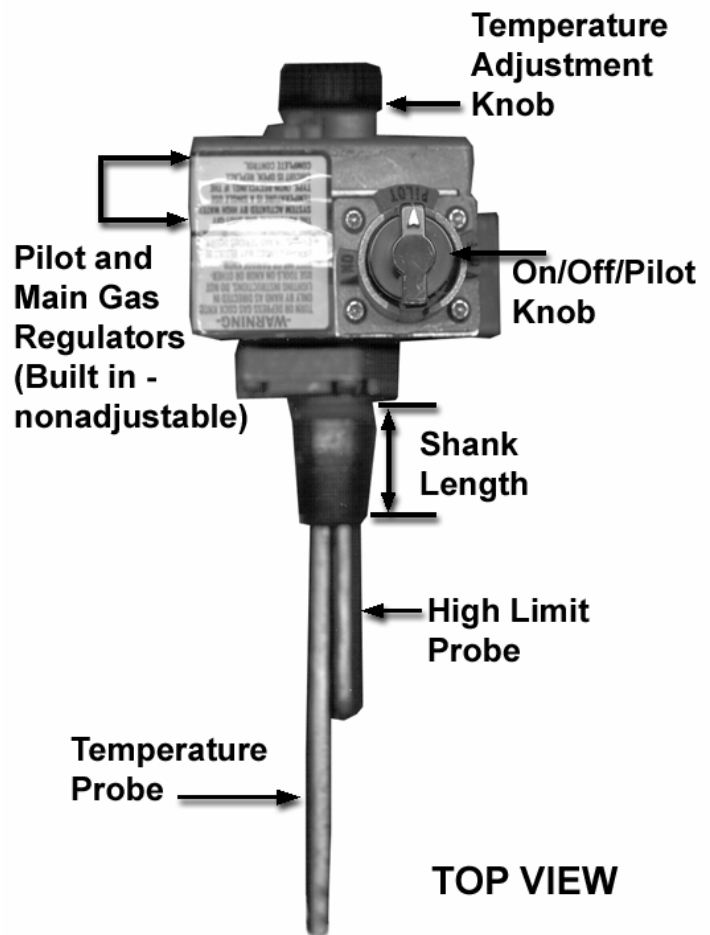

**Gas:** When you prepare to light the pilot, you are instructed to turn the top knob to the pilot position and depress the knob. When the knob is depressed gas will flow to the pilot burner only. You then have to (manually) ignite this pilot gas. When the pilot is lit, the flame must heat the thermocouple until it generates sufficient electricity to the gas valve to allow you to release the knob while gas continues to flow to the pilot. When the top knob is turned to the “ON” position, gas is also available to the main burner if the thermostat calls for heat.

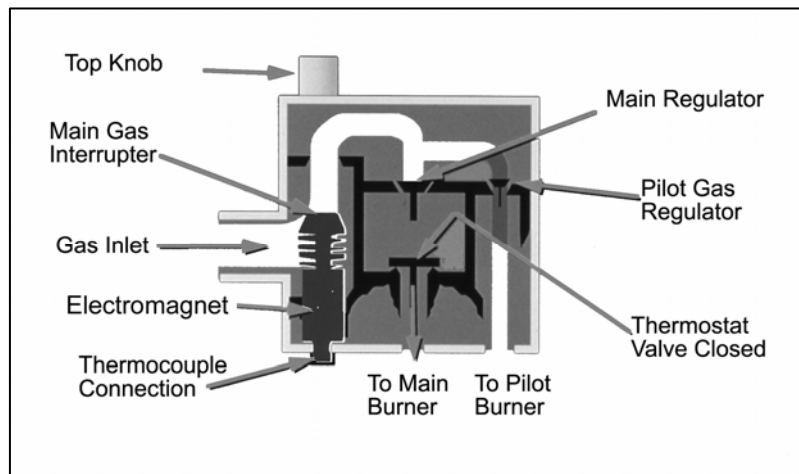

## RESIDENTIAL GAS AND ELECTRIC WATER HEATER SERVICE HANDBOOK

---

### Residential Gas - continued

**Water Flow:** When a hot water faucet is opened, water pressure from the well tank or street main forces cold water into the water heater. This pushes hot water out of the tank.

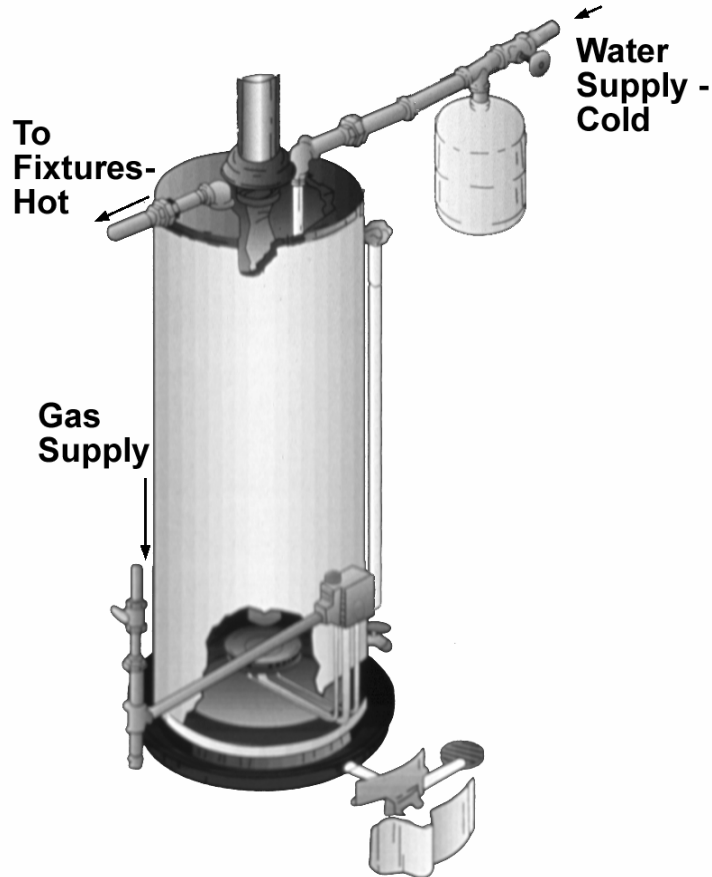

**Operation:** A residential water heater is not a precise operating appliance. Because the water heater relies on the expansion and contraction of a metal rod, when the thermostat dial is set at an indicated setting ("σ" is recommended as a starting setting. This is approximately 120 degrees F.) the heater may shut off at 110 to 130° F. The heater will consistently shut off at this same temperature. For this same reason, water temperature may drop 15 - 25° F, around the temperature probe, before the main burner is activated. Keep in mind that hot water in the upper part of the tank will probably be very near the "shut off" temperature of the control while incoming cold water drops the water temperature around the thermostat probe. Also, short repeating heating cycles caused by small hot water uses can cause temperatures at the point of use to exceed the thermostat setting by up to 30° F.

Setting	Approximate Temperature (°F)	Time To Cause Injury
Hot (▲)	120° ± 10°	5 Minutes
A	130° ± 10°	30 Seconds
B	140° ± 10°	5 Seconds
C	150° ± 10°	1.5 Seconds
Very Hot	160° ± 10°	Under 1 Second

## RESIDENTIAL GAS AND ELECTRIC WATER HEATER SERVICE HANDBOOK

### Residential Gas - continued

#### Service:

**Air:** A gas burning appliance requires the oxygen contained in 12.5 cubic feet of air (at sea level) for every 1000 BTU of heat that is generated. If your water heater has a BTU per hour input of 40,000 BTU then a minimum of 500 (40 times 12.5) cubic feet of clean air must be available. This oxygen will mix with the gas for a clean, blue flame in the burner chamber and provide dilution air for flue products.

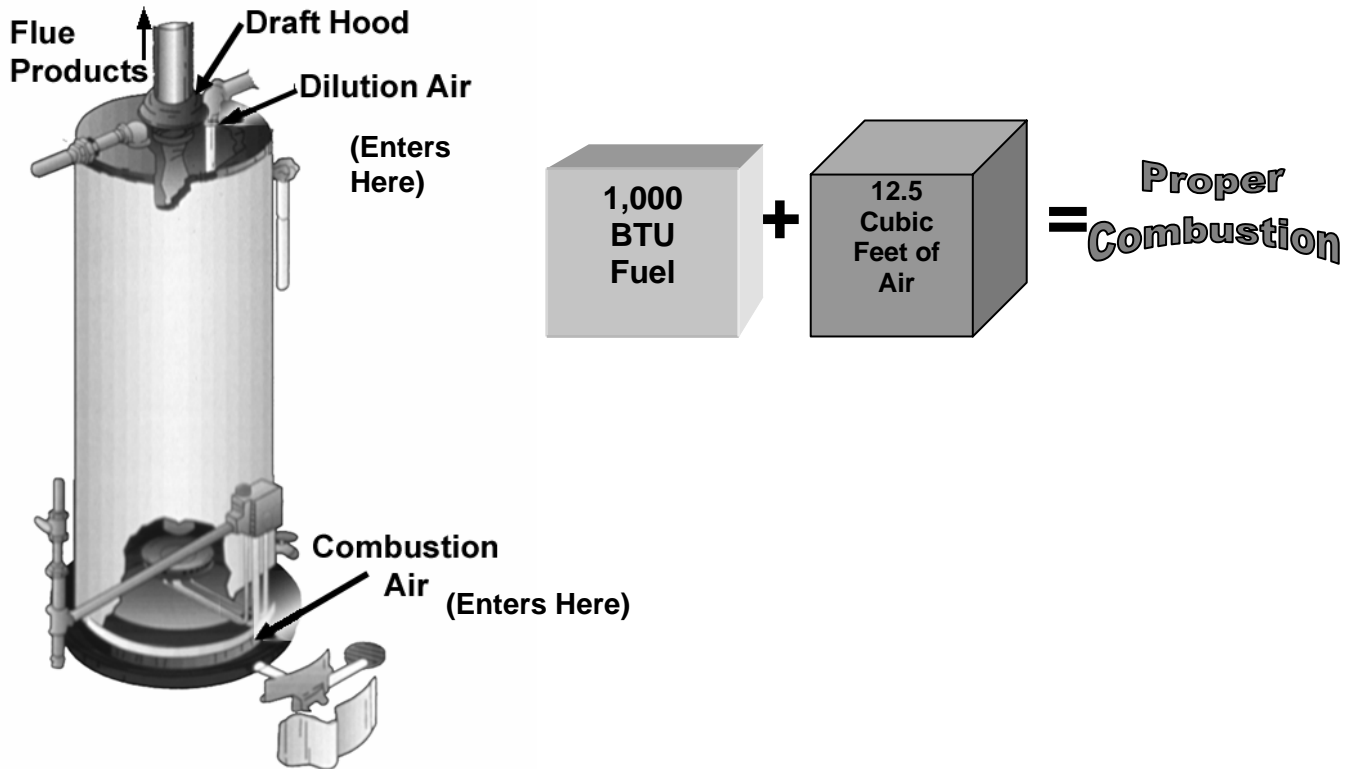

Do not forget that your gas (or oil) furnace and gas clothes dryer also require a like amount of air.

When calculating air supply provisions, also consider the presence of whole house exhaust fans or other exhaust fans competing for the same air supply.

Air must be allowed to enter the heater chamber from the base of the heater and also enter the flue vent from below the draft hood. Do not block these areas with insulation blankets or obstructions lying around the base of the heater.

**Lack of Oxygen:** If a sufficient supply of oxygen (air) is not available for combustion and dilution, the result will be:

- Pilot outage
- Yellow burner flame
- Sooting water heater
- Possible carbon monoxide
- Smell of burnt gas in the room

# RESIDENTIAL GAS AND ELECTRIC WATER HEATER SERVICE HANDBOOK

## Residential Gas – continued

The instruction manual gives guidelines under “Air Requirements” and “Unconfined “ or “Confined Space” sections. If you want to test for a lack of air:

1. Turn on every appliance and fan that exhausts air from the utility room and/or house. Make sure all windows and doors are closed, as well as chimney dampers.
2. Open a hot water faucet so that the main burner will ignite
3. Remove the outer door of the water heater – not the inner door
4. Monitor the flame characteristics for several minutes

If the flame begins to “yellow” open a door or window, to the outdoors, to see if additional air corrects this back to blue. If it does, the room needs more air supply. Perform draft test at draft hood of water heater with match or smoke source to verify.

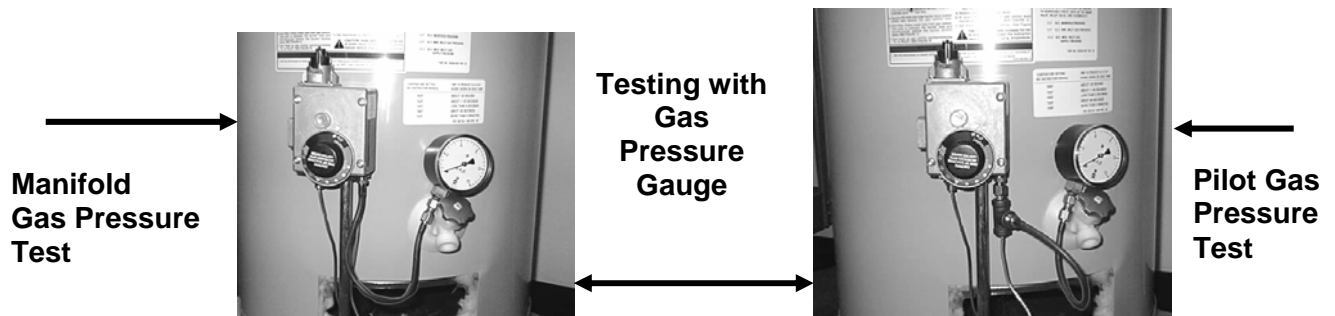

Gas pressure checks are done with flowing gas.

**Supply gas pressure** checks are taken ahead of the gas control and as close to the heater as possible.

**Pilot gas pressure** checks are taken by using fitting adapters to tap into the pilot gas tubing.

**Manifold (main burner) gas pressure** is measured using the Allen wrench tap on the bottom of the control valve.

Desired gas pressures will be noted on the gas valve label.

If ...	... then
supply gas pressure is under desired pressure setting	<ul style="list-style-type: none"> <li>• increase supply gas pressure regulator setting and,</li> <li>• increase supply gas piping size.</li> </ul>
supply gas pressure is over desired pressure	<ul style="list-style-type: none"> <li>• add gas pressure regulator.</li> <li>• reduce setting on existing regulator.</li> </ul>
pilot gas pressure is more than +/- .3 inch W.C. from desired	replace the control valve.
manifold gas pressure is more than +/- .3 inch W.C. from desired	replace the control valve.

Additional considerations when pilot or main burner flames are too large or too small:

- Incorrect orifice
- Dirt in orifice or gas supply tubing

# RESIDENTIAL GAS AND ELECTRIC WATER HEATER SERVICE HANDBOOK

## Residential Gas - continued

### Sooting causes:

If ...	... then
the burner is clean but the chamber and/or flue are sooted	check for lack of supply air.
the main burner, chamber and flue are sooted	check the following: <ul style="list-style-type: none"> <li>• incorrect orifice</li> <li>• excessive gas pressure</li> <li>• loose main burner</li> <li>• cross threaded orifice</li> <li>• gas control valve gas seepage</li> <li>• loose gas connection in burner assembly.</li> </ul>

### Electrical Testing

This type of water heater has its own electrical generating system.

When two dissimilar metals are joined together and this joint is heated, a small, electrical current will be produced. A thermocouple uses this science.

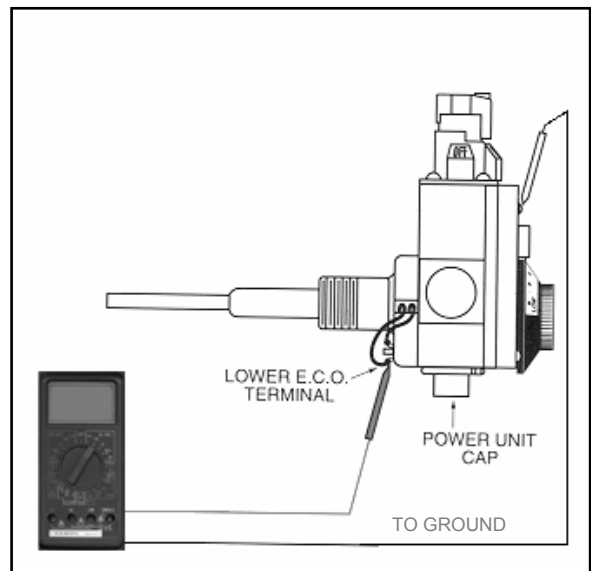

### Thermocouple output test

#### Procedures/Conditions:

Meter set for DC millivolt testing

Test from lower ECO (emergency cut off or energy cut off) solder joint to ground.

Note: If pilot will not stay lit, manually hold the top knob down in the pilot position. This allows gas to flow to the pilot. Light the pilot and continue to hold this knob down while conducting the test.

If ...	... then
reading test of at least 13 MV is not present	<ul style="list-style-type: none"> <li>• check that flame contacts end of thermocouple</li> <li>• replace thermocouple.</li> </ul>
reading test of at least 13 MV is present	continue to next test.

# RESIDENTIAL GAS AND ELECTRIC WATER HEATER SERVICE HANDBOOK

## Residential Gas - continued Electrical Testing– continued

**Millivolt dropout test** through copper magnet winding and ECO (Emergency Cut Off)

**Procedure:** Move meter probe to upper ECO solder joint and ground

If ...	... then
reading of at least 10 MV is not present	replace the control valve.
reading of more than 10 MV is present but, gas to the pilot shuts off each time knob is released	replace the control valve.

**Safety drop out test** – the safety gas shutoff should interrupt gas through the valve when MV current drops to 1-3 MV.

**Procedures:**

Meter still connected to upper ECO solder joint and ground.

Turn Top Knob to “off” position

Millivolt output will decrease as thermocouple cools

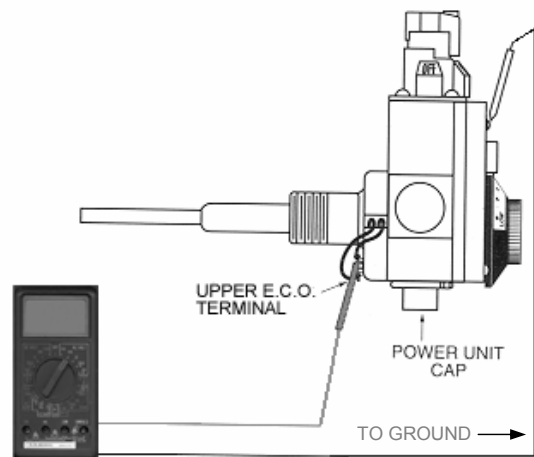

If...	... then
internal safety does not activate between 1 and 3 MV (you will hear a “click” inside the valve)	replace the control valve.
*internal safety does activate between 1 and 3 MV	valve is within tolerance and will interrupt gas flow if pilot loses heat or ECO opens.

\*Note: A “click” sound should be heard from the valve as the main gas interrupter snaps up to the “closed” position.

## Condensation

Flue gas products contain moisture. If these flue gas products are cooled to their “dew point”, they become visible moisture – condensation.

Flue gas may become cooled by:

- Cold supply air temperatures
- Cool surfaces – generally, if tank water temperatures drop below 110°F, the flue pipe surface and/or bottom tank head will be cool enough to cause condensation.
- Increased combustion efficiency – higher thermal efficiency means that an increased amount of heat is transferring from the flue gas into the water. If you transfer (approximately) 87.5%, or more, the moisture in the flue gas will condense.

# RESIDENTIAL GAS AND ELECTRIC WATER HEATER SERVICE HANDBOOK

## Residential Gas – continued

### Condensation is a mild acid – it will corrode steel

**Condensation** is usually noted when:

- water dripping is heard (only) while the main burner is on,
- there is “water” around the heater just after the heater has been operating,
- there are small, black or red granules on the main burner or top of the heater or
- corroded jacket or vent piping is noted.

If ...	... then
any of the above conditions exist	<ul style="list-style-type: none"> <li>• raise the supply air temperature or</li> <li>• increase stored water temperature or</li> <li>• increase the size of the tank</li> </ul> <p>You would not wish to lower combustion efficiency – this would waste gas. Use materials (stainless steel, PVC etc.) that will not be affected by the condensation</p>

### Suggested Multiple Heater Water Piping Required For Proper Operation of Top Connect Models

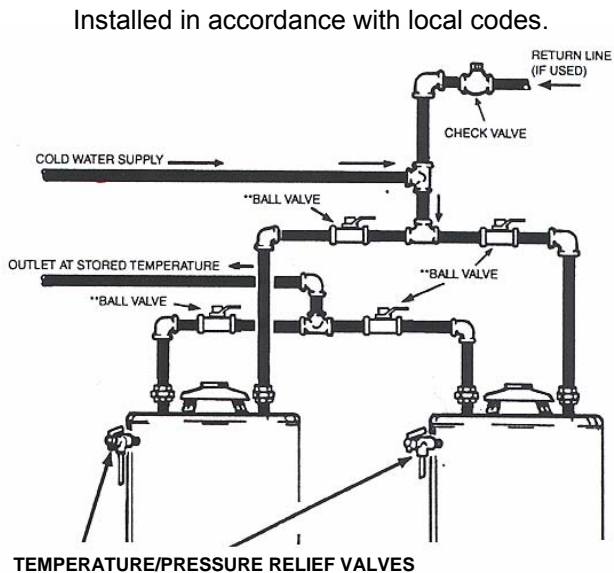

# RESIDENTIAL GAS AND ELECTRIC WATER HEATER SERVICE HANDBOOK

---

## Residential Gas – continued

### Exhaust Venting Notes

Follow current National Fuel Gas Code requirements for proper installation.

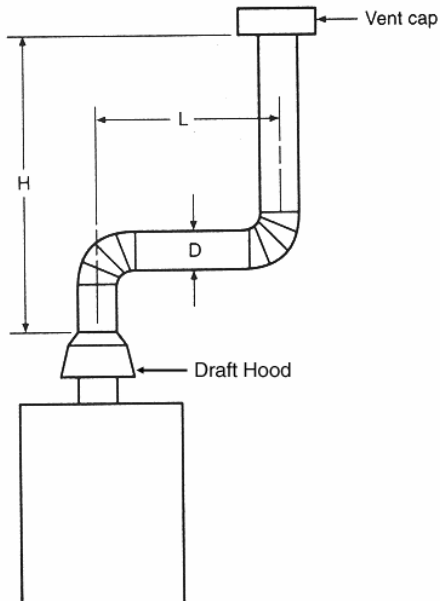

“D” – Typically, same or larger diameter as Draft Hood outlet

“L” – Horizontal piping slopes upward ¼” per foot from heater to chimney or vertical vent  
Length of horizontal not more than 75% of “H”

“H” – Not less than 5 feet

Maximize vertical distance to first elbow

## FLAMMABLE VAPOR IGNITION RESISTANT DESIGN

This section will address the changes brought about by the introduction of FVIR compliant products. Other than items mentioned here, the construction, installation, and service will remain the same as discussed in the primary handbook.

The FVIR acronym stands for "Flammable Vapor Ignition Resistant." The AO Smith products are based on "Corderite Combustion Containment" known as "C3 Technology™". The C3 Technology design features a sealed (from non designated air intake openings) combustion chamber and a "flame arrestor" component.

This class of residential gas water heaters meet the new ANSI standards and testing protocols (ANSI Z21.10.1) established to deal with the accidental or unintended ignition of flammable vapors, such as those emitted by gasoline. Virtually all gas-fired, atmospherically vented, residential water heaters manufactured in the United States with BTU ratings of 75,000 or less are required to meet this new ANSI standard effective July 1, 2003. The current implementation schedule for C3 TECHNOLOGY compliant residential gas-fired products is shown in the following table. These dates are subject to change.



# RESIDENTIAL GAS AND ELECTRIC WATER HEATER SERVICE HANDBOOK

IMPLEMENTATION CATEGORY	ANTICIPATED INTRODUCTION	CLASS OF PRODUCTS INCLUDED IN THIS CATEGORY
Phase I	July 1, 2003	30, 40, and 50 gallon atmospheric vented. (Manufactured housing models are excluded.)
Phase II	January 1, 2005	30, 40, and 50 gallon power-vented models. (Manufactured housing models are excluded.)
Phase III	July 1, 2005	All other gas-fired models with inputs of 75,000 BTU or less.

This supplement addresses the July 1, 2003 compliant products.

In addition to the standard water heater design discussed in the main service handbook, the C3 Technology design also includes:

- A LDO (Lint Dust and Oil) screen over the combustion air intake
- A Flame Arrestor
- A combustion chamber Thermal Cut Off (TCO) limit

An additional tool for these products might be a vacuum cleaner with both blowing and vacuuming capabilities. Also include the long, narrow crevasse accessory.

## LDO SCREEN (LINT, DUST, OIL) SCREEN(S)

An easy to clean screen designed to minimize lint, dust and oil based contaminants from being drawn into the "Flame Arrestor" along with make up – combustion - air. There may be one or two of these screens. The LDO screen must be installed with the arrows on the right and left side facing up to function properly. (The arrows are located on two mounting tabs on each side of the screen).

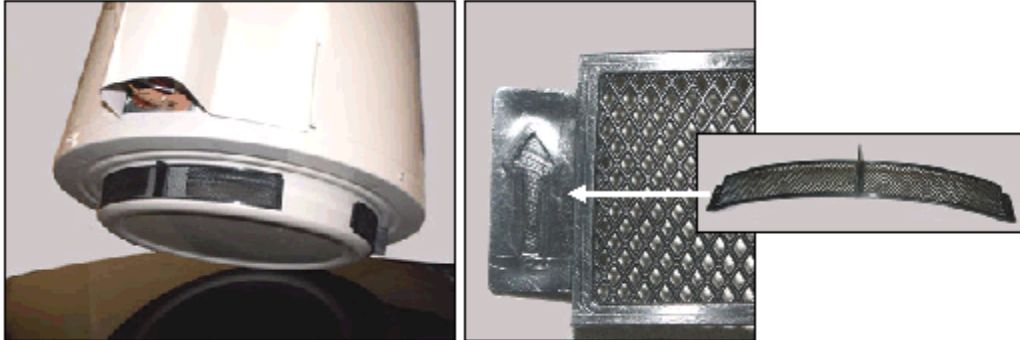

### Service:

Inspect the LDO screen(s) regularly. Clean or wash as necessary.

Pulling the tab located in the middle of the screen will remove the screen. Reinstall the clean screen by inserting the end tabs into the jack with the arrows pointing up.

### Possible Service issues associated with a blocked screen:

- Poor combustion – yellow flame, possible sooting
- Pilot outage resulting from a lack of oxygen
- Pilot outage resulting from to increased combustion chamber temperature below the main burner. This may open the automatic reset, thermal cut off switch (TCO).

# RESIDENTIAL GAS AND ELECTRIC WATER HEATER SERVICE HANDBOOK

---

## FLAME ARRESTOR

Made from Corderite, a fireproof ceramic material, the flame arrestor is built into the base of the water heater. Combustion air is drawn in through the LDO screen (s). After entering the bottom area of the water heater, this air passes up through the small ports of the flame arrestor and into the combustion chamber.

In the event flammable vapors are introduced accidentally into the combustion chamber, the flame arrestor is designed so any flames burn off the top surface of the arrestor and cannot escape down through the arrestor. The arrestor works somewhat like a check valve.

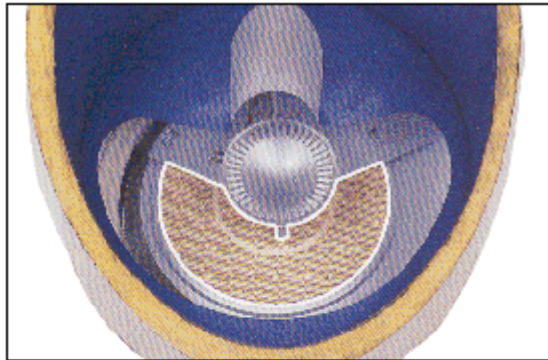

**Top cutaway view of flame arrestor.**

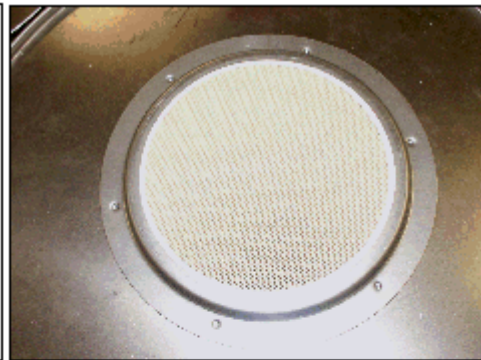

**Bottom view of flame arrestor.**

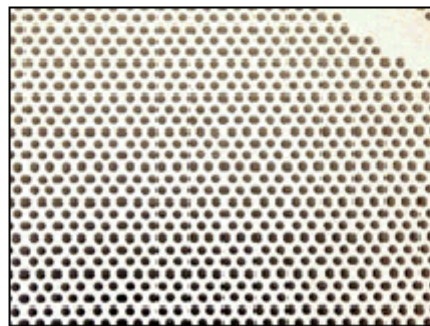

**Close up view of Corderite flame arrestor material.**

### **Service:**

Inspect the bottom ports of the flame arrestor by removing the LDO screen (s) and using a mirror and flashlight. Clean the ports if necessary by vacuuming the bottom of the arrestor.

Inspect the top of the flame arrestor by removing the inner door and burner assembly. Lift the heat shield located on the bottom of the chamber. Inspect with the mirror and flashlight. Vacuum or blow down any blocking material. If you blow down through the ports, be certain to also vacuum below the arrestor.

## RESIDENTIAL GAS AND ELECTRIC WATER HEATER SERVICE HANDBOOK

---

If there has been a flammable vapor ignition, a qualified service agent needs to inspect the arrestor for cracks. The arrestor is not a replaceable part – the heater would need to be replaced.

### Possible service issues associated with the flame arrestor.

- Poor combustion – yellow flame, sooting, possible carbon monoxide production.
- Pilot outage due to lack of oxygen. Continued pilot outage or finding that the LDO screen(s) is heavily blocked would warrant inspection of the flame arrestor.
- Pilot outage due to increased combustion chamber temperatures below the main burner. This may open the automatic reset, thermal cut off switch (TCO).
- The flame arrestor having contained a flammable vapor ignition. The TCO will open and the chamber and arrestor should be inspected by a qualified service agent.

## COMBUSTION CHAMBER TEMPERATURE SENSOR

The C3 Technology water heaters will come equipped with a thermal cutoff (TCO) device that is integral with the thermocouple. Temperature cutoff points range from 160°C to 200°C depending on model. The TCO is an automatic reset thermal switch. When activated it will open the thermocouple circuit and shut off the main and pilot burner gas flow. The pilot would have to be relit after the TCO has had sufficient time to cool down (sensor is below 120 degrees F).

The TCO performs two primary functions:

- In the event of flammable vapor ignition inside the combustion chamber, it senses the corresponding increase in temperature and shuts off gas flow to the main and pilot burners.
- If excessive temperatures inside the combustion chamber indicate poor combustion due to a clogged LDO screen or inadequate air for combustion, the TCO will shut off gas flow to the main and pilot burners.



190°C TCO

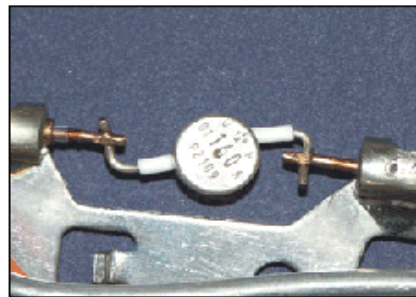

160°C TCO

### SERVICE:

There is no routine service associated with the TCO. The standard thermocouple millivolt output checks described in this service handbook still apply. Millivolt readings indicate that the TCO is closed. An open TCO (within a cool chamber) would indicate that the assembly must be replaced.

## RESIDENTIAL GAS AND ELECTRIC WATER HEATER SERVICE HANDBOOK

---

The TCO is an integral part of the thermocouple and not replaceable as a separate item. A pilot burner assembly must be reinstalled. On repeated calls of no hot water or pilot outage, a clogged/dirty LDO screen might be the cause and should be checked. Keep in mind this TCO will shut off the pilot and main burner when activated.

With the different cutoff temperature set-points of TCO devices for different model water heaters, it is important that the correct part is used when replacement of the pilot burner assembly is necessary.

### **Possible service issues associated with the Thermal Cut Off switch being opened:**

- Pilot outage due to increased combustion chamber temperatures below the main burner. This may open the automatic reset, thermal cut off switch (TCO).
- The flame arrestor having contained a flammable vapor ignition. The TCO will open and the chamber and arrestor should be inspected by a qualified service agent.

## **ONE PIECE PILOT BURNER ASSEMBLY**

C3 Technology models feature a "one piece" pilot burner assembly. This assembly will be covered under a minimum 6 year parts warranty on all C3 Technology models, 10 years on premium models.

There are five main components that make up this pilot assembly:

1. Thermocouple with integral Thermal Cut Off switch (TCO).
2. Pilot burner w/orifice and tubing
3. Piezo igniter cable
4. Pilot assembly seal/grommet (orange).
5. An inner door gasket (white) will also be included.

## RESIDENTIAL GAS AND ELECTRIC WATER HEATER SERVICE HANDBOOK

---

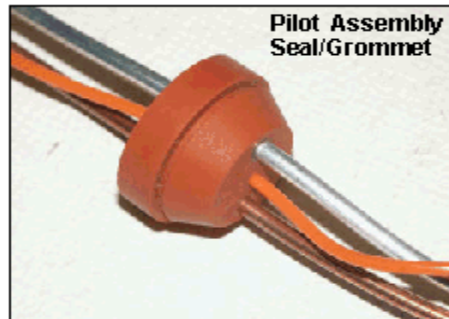
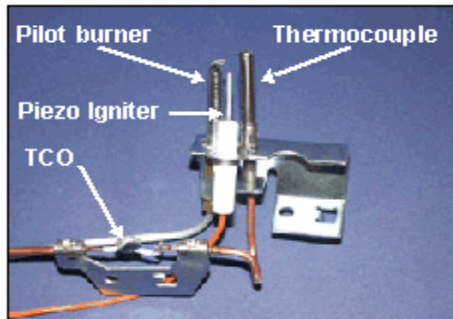
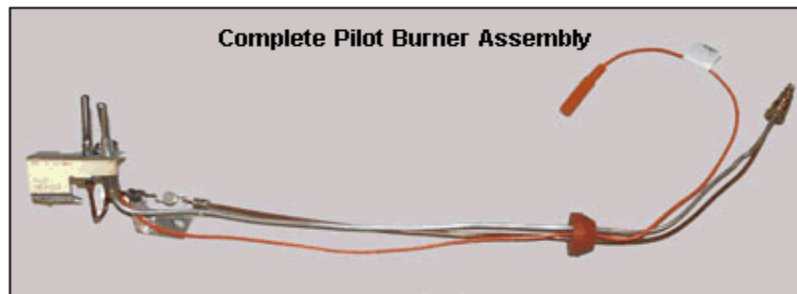

### ***To replace a pilot assembly:***

1. Turn off the gas supply
2. Disconnect the piezo cable from the piezo button (connection near gas control valve).
3. Disconnect the pilot tubing, thermocouple and main burner tube from the bottom of the gas control valve.
4. Remove (2) 3/8 inch nuts securing the inner door.
5. Remove the entire burner assembly.
6. Remove screw securing pilot burner assembly to pilot mounting bracket.
7. Remove pilot assembly - with orange gasket – from the back side of the inner door.
8. Reinsert new pilot assembly into back side of inner door. Wetting the orange gasket may help in securing the gasket into place.
9. Reattach the new pilot assembly to the pilot mounting bracket.
10. Inspect/replace the white, inner door gasket before making the connections to the bottom of the gas control valve.
11. Reattach the piezo cable to the piezo button.
12. Remount the inner door.
13. Follow the pilot lighting instructions including gas and gasket leak checks.
14. Install the outer door.

### ***SEALED COMBUSTION CHAMBER***

The combustion chamber is factory sealed around the flame arrestor and the upper and lower perimeter of the chamber. Access for service is provided through an inner door as with current product. However, this inner door is now sealed with; a door gasket, a pilot assembly grommet type seal, and a main burner tube boot/sleeve type seal.

The three seals on the inner door should be checked every time any service is performed. The sight glass should be checked to insure it is not damaged or missing. The pilot tube and thermocouple routing should be straight (not bent at an angle close to the surface of the seal) as it passes through the pilot assembly seal.

# RESIDENTIAL GAS AND ELECTRIC WATER HEATER SERVICE HANDBOOK

A "five point inner door seal inspection" is outlined below:

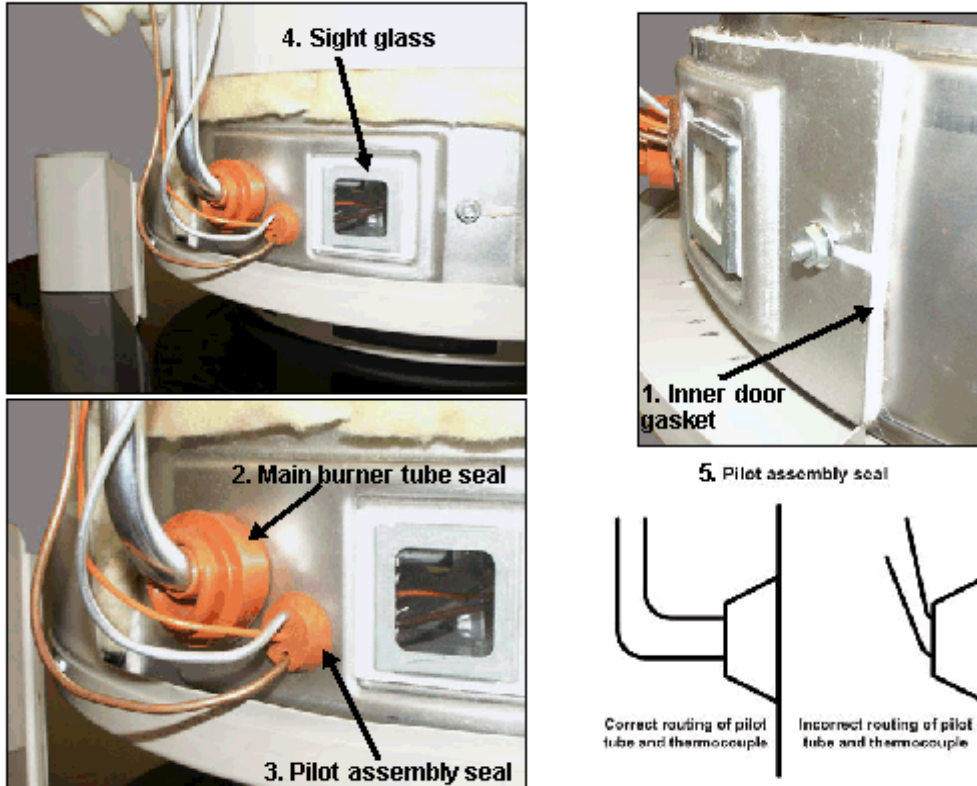

### ***Five point inner door seal inspection:***

1. Inner door gasket condition and fit.
2. Main burner tube seal condition and fit.
3. Pilot assembly seal condition and fit.
4. Sight glass, condition; present, not broken or cracked.
5. Straight routing of the thermocouple and pilot burner tube through the pilot assembly seal.

These are all critical to maintaining the C3 TECHNOLOGY integrity of the combustion chamber.

### ***PIEZO IGNITER***

C3 TECHNOLOGY models will feature a Piezo igniter to light the pilot burner.

The push button switch will be located on the top of the gas control valve. There will be a plug connector between the push button and the igniter wire which is part of the pilot burner assembly.

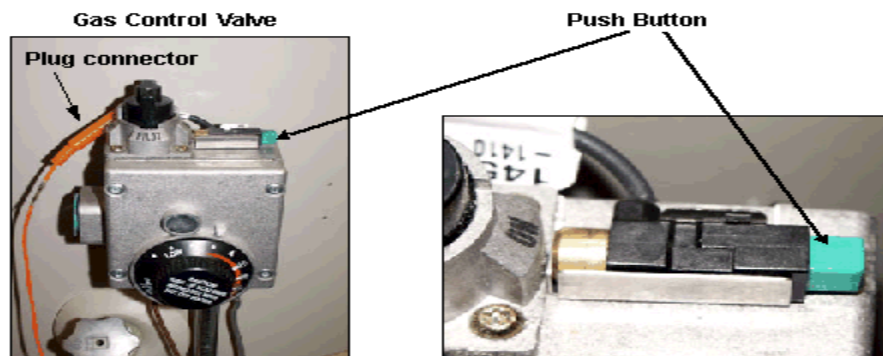

## FLAMMABLE VAPOR IGNITION RESISTANT WATER HEATER SERVICE TIP:

### TO KEEP YOUR WATER HEATER IN PEAK PERFORMANCE

Like other appliances, your water heater will need occasional servicing to maintain peak performance. Sufficient air flow is crucial to the proper operation of your water heater. This publication addresses one possible cause of restricted air flow, and the procedure for its prevention and correction. Signs of restricted air flow are yellow flames, pilot outage, sooting, or unstable flame. Before starting, consult the sections of your owner's manual dealing with condensation, air requirements, gas supply, venting, and cleaning the air intake screen. Also, make sure that your water heater is properly sized for your home. An undersized water heater may result in condensation which can drip onto the flame causing a pilot outage.

Your water heater is built to the current industry safety standard and meets all FVIR (flammable vapor ignition resistant) requirements. This assures that any flammable vapors drawn into the combustion chamber and ignited can not ignite remaining flammable vapors on the exterior of the water heater causing a fire or explosion. This design includes a flame arrestor and one or two air intake screen(s). These screen(s) prevent larger particles of dust or lint from entering the water heater, thus restricting air flow and causing improper combustion. The owner's manual asks you to visually check and clean the screen(s) as necessary.

Smaller particles may pass through these screens and lodge in the flame arrestor.

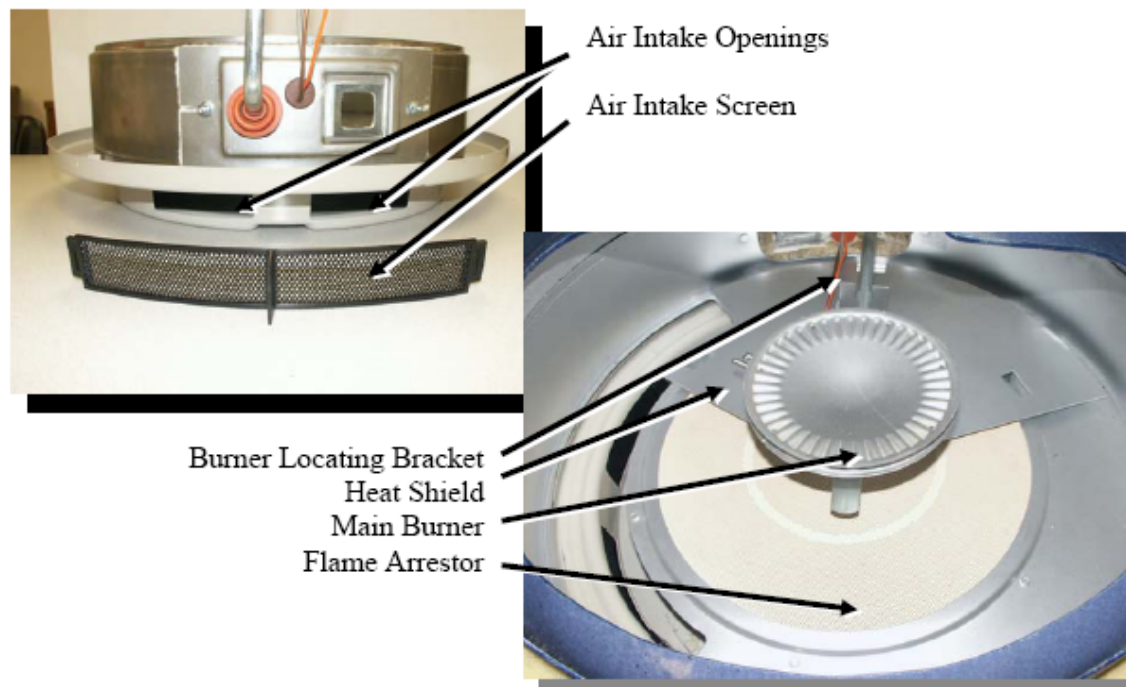

The following paragraphs address the cleaning of the flame arrestor and the combustion chamber. This procedure should be done in two phases: 1) under the water heater and 2) the combustion chamber. Required tools are commonly found in most homes, and additionally are available in most home stores or super centers.

## RESIDENTIAL GAS AND ELECTRIC WATER HEATER SERVICE HANDBOOK

---

### Tools:

- Vacuum cleaner with crevice and curtain attachments.
- Twisted wire brush (household cleaning brush)
- Flashlight
- Small mirror 2" X 3"
- 3/8", 7/16", and 3/4" inch open end wrenches
- 3/8 inch nut driver
- Small container of soapy water and an applicator.

### Procedure

Turn the water heater top knob to "off" and allow the burner area to cool. Then, remove the plastic air intake screen(s) and use a small mirror and flashlight to view the bottom of the flame arrestor. Using the crevice tool, vacuum all dust and other particles from beneath the water heater. To clean the bottom of the flame arrestor, use a common household cleaning brush that will pass through the air intake opening at the base of the water heater and extend into the water heater 2/3 the distance to the back. Use a gentle back and forth motion. Vacuum any remaining debris that may have fallen out of the flame arrestor. Re-insert the air intake screen when finished. At this point, relight the pilot, and check water heater for operation. Allow an entire heating cycle to complete to assure proper operation.

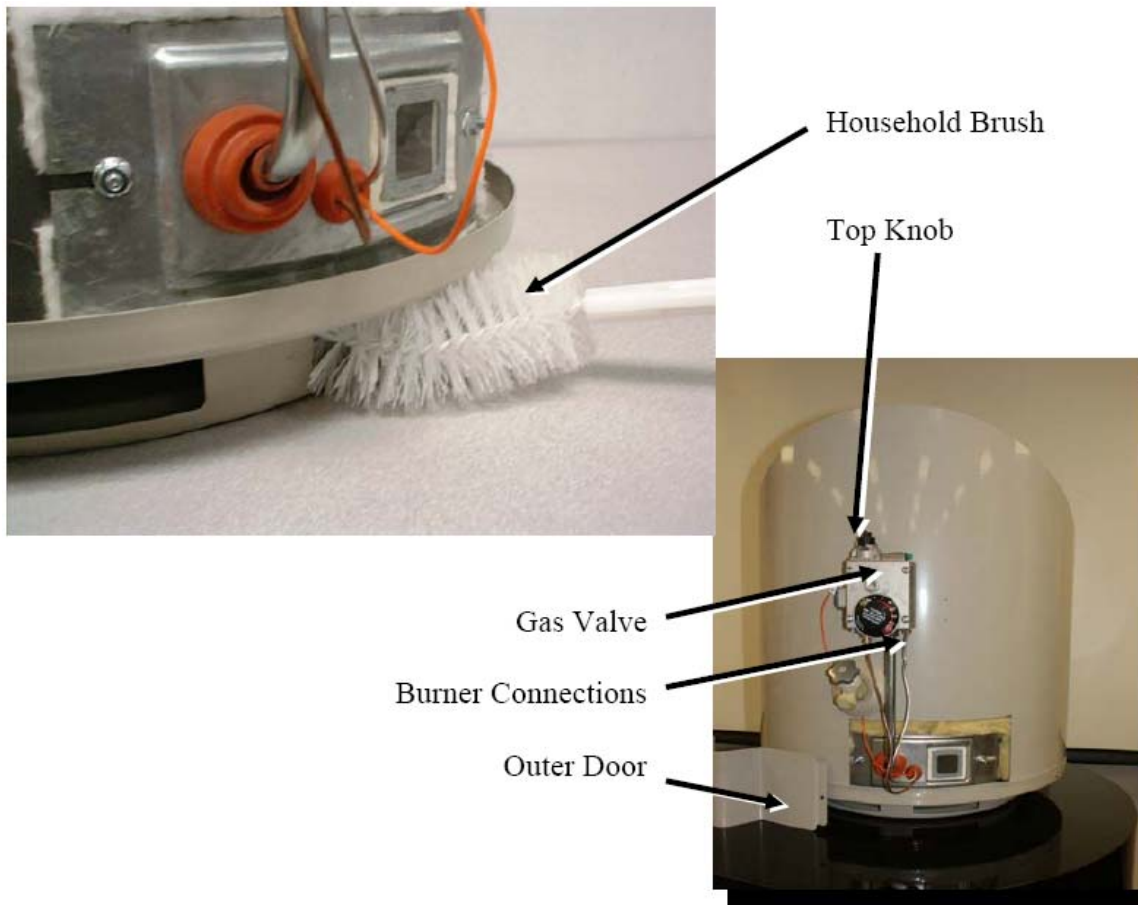

**The following procedure requires abilities equivalent to that of a licensed Tradesman. Contact a qualified service agent for assistance.**

If the yellow flame or pilot outage problem persists, perform the following procedure. Turn the water heater top knob to "off" and allow the burner area to cool completely, approximately 15 minutes. Turn off the supply gas at the supply gas line if applicable. Disconnect the three connections from the bottom of the gas valve, being careful to note their location.



# RESIDENTIAL GAS AND ELECTRIC WATER HEATER SERVICE HANDBOOK

---

## **WARNING**

Do not bend the gas valve connections too far; doing so may result in damage.

Remove the outer door from around the burner tubing at the base of the water heater. Remove the Piezo igniter (with the orange wire) from the gas valve by sliding it back toward the tank (leave the orange wire in the inner door assembly).

Remove the 3/8" nuts, holding the inner door and white gasket in place. Place some protection such as newspaper to protect the floor from debris. Carefully remove the burner from the combustion chamber. There may be soot or other materials collected on the top of the main burner; try not to dump any debris off of the burner until it and the inner door have been removed from the water heater.

**TAKE CARE NOT TO DAMAGE THE WHITE GASKET ON THE INSIDE OF THE INNER DOOR.**

Inspect the radiation shield (thin circular metal sheet under the burner and above the flame arrestor). If any of the sides of the radiation shield are touching the base (disrupting air flow), small feet can be obtained free of charge by contacting our call center at 800-527-1953 and requesting them.

Vacuum the main assembly and pilot burner assembly. Vacuum the top of the radiation shield located inside the burner chamber. Use the vacuum drapery brush attachment to clean the inside of the combustion chamber and the exposed area of the flame arrestor. Use the crevice tool to vacuum under the radiation shield as much as possible without bending the shield upward more than one inch or so.

Re-insert the burner taking care that the main burner tube is seated in the burner positioning bracket. Carefully reposition the inner door w/gasket over the bolts on the combustion chamber. Do not tighten the nuts down until the main burner, pilot burner, and thermocouple are attached and tightened. Make sure that the white fibrous door gasket is not folded over and protrudes out from the inner door in all directions. Then tighten the 3/8" nuts to hold the inner door in place.

Check the gas connections for proper fitting and then light the pilot, following the directions on the side of the water heater. Once the pilot is lit, turn the valve to the "ON" position and ignite the main flame. Brush soapy water on the gas connections and look for bubbling. This is an indication of a gas leak. If bubbles appear, shut off gas supply and check fittings. Re-light the pilot and check for leaks again, repeating the soapy water solution method.

## **Important Service Reminder**

Any time service is performed on C3 TECHNOLOGY product the Five Point Inner Door Seal Inspection outlined in the Sealed Combustion Chamber section should be performed and the LDO Screen (s) should be inspected for proper installation (arrows up) and cleaned before leaving.

## **Other features**

All C3 TECHNOLOGY models will feature Green Choice by having a low NOx (nitrous oxide) burner which meets SCAQMD rule 1121. All C3 TECHNOLOGY models will have a brass drain valve standard.

## RESIDENTIAL GAS AND ELECTRIC WATER HEATER SERVICE HANDBOOK

---

**See the “Technical Bulletins Section” of this manual for explanations of:**

Water Hammer  
Mineral Buildup  
Aluminum Hydroxide  
Condensation  
Discolored Water  
Smelly Water  
Chlorination Process  
Lack of hot water  
Thermal Expansion  
Temperature and Pressure Relief Valve Operation

**Parts Replacement** – The parts on these models may change due to improvements/changes in the products. To order the current, correct replacement part for your model gas water heater, you must know the model number and (complete) serial number of your water heater. This information will be located on a black and white label, on the front of your water heater – this label will also display a star within a circle (the CSA symbol). A sample might be:

Model “PCVG-50 – 250” “Ser No. MB03-(numbers) – 250”.

**To order parts, contact your local A.O. Smith Contractor or Distributor, phone AOS parts at 800-433-2545 or contact A. O. Smith on Web site:  
“[www.aosmithwaterheaters.com](http://www.aosmithwaterheaters.com)”**

# RESIDENTIAL GAS AND ELECTRIC WATER HEATER SERVICE HANDBOOK

## STANDARD RESIDENTIAL ELECTRIC WATER HEATERS

### INSTALLATION SOME MODELS MAY HAVE SIDE OR REAR CONNECTIONS

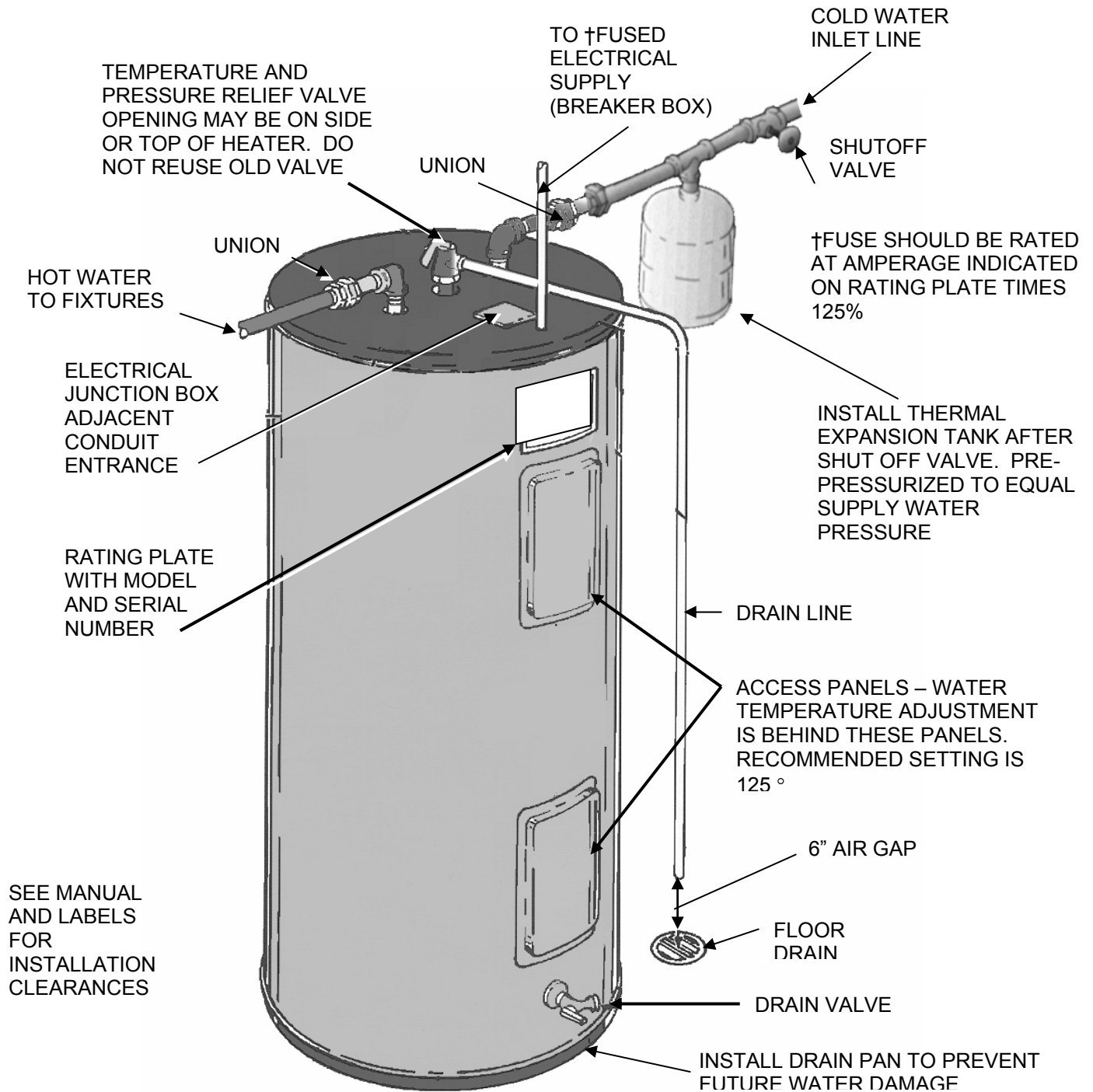

**INSTALLATION MUST FOLLOW LOCAL CODES AND INSTRUCTION MANUAL GUIDELINES.**

# RESIDENTIAL GAS AND ELECTRIC WATER HEATER SERVICE HANDBOOK

## STANDARD RESIDENTIAL ELECTRIC WATER HEATERS

This portion of this manual applies to the Operation and Servicing of Residential Electric, Tank Type, Water Heaters. The illustrations are for two element models but the information also applies to single element models.

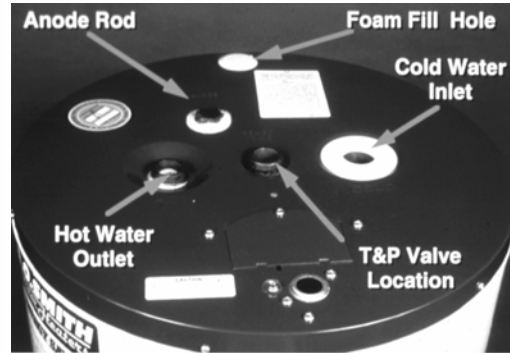
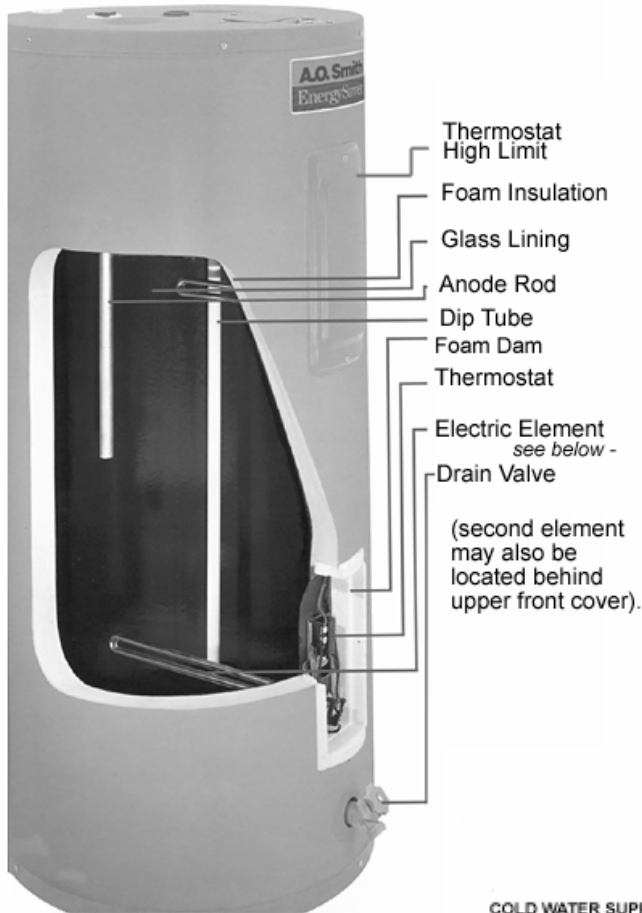

### Multiple Heater Water Piping Required for Proper Operation of Top Connect Models

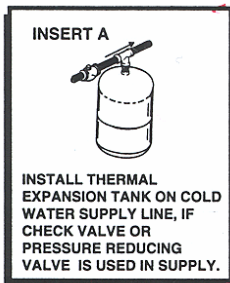
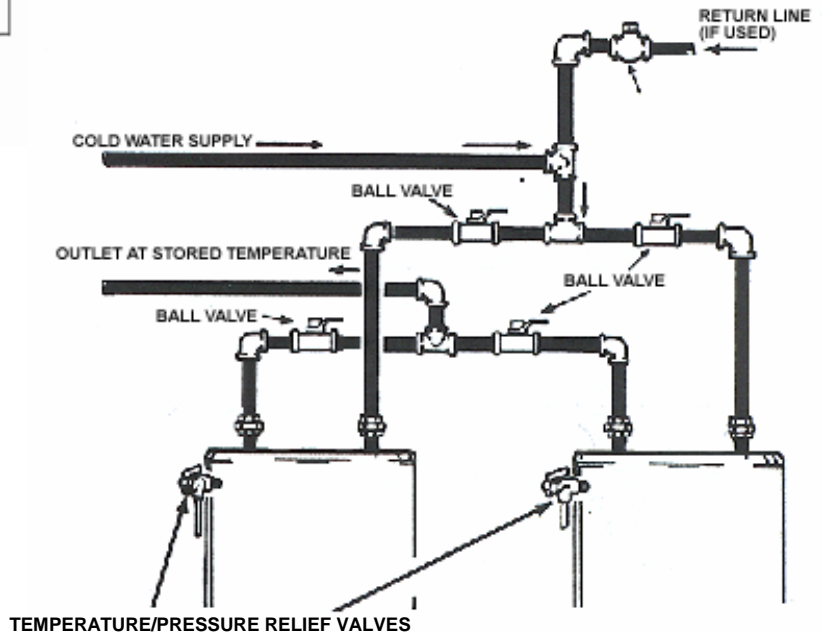

# RESIDENTIAL GAS AND ELECTRIC WATER HEATER SERVICE HANDBOOK

## STANDARD RESIDENTIAL ELECTRIC WATER HEATER SERVICE GUIDELINES

### Construction

See “General Section” for features common to both gas and electric models.

### Miscellaneous:

**Amperage** (Amps) (1 phase) = **Watts** divided by Volts

**Amperage** (3 phase) = (Watts X .577) divided by Volts

**KW Required** = (GPH X 8.25 X Temp. Rise X 1.0) divided by (3413)

**Ohms** = Volts divided by Amperes

**One kilowatt** is equal to 1000 watts

**One kilowatt** is equal to 3,413 BTU

**Recovery Rate** = (KW X 3413) divided by (Temp. Rise X 8.25)

**Rise (F°)** = (KW X 3413) divided by (GPH X 8.25)

**Supply electrical fusing** or breakers should be sized at least 125% of expected heater amperage.

**Water weighs** 8.25 pounds per gallon at 120°F (49°C).

**% of Hot water** = (Mixed temp. – Cold) divided by (Hot temp. – Cold)

### Heating element(s)

This style water heater will have one or two electric, heating elements immersed in the tank. One element will always be located low in the tank; a second element is commonly located down about 1/3 of the tank height from the top of the tank. These elements will seldom be wired to operate at the same time. (If they operate at the same time, amperage draw doubles, wire gauge size increases, fuse size increases and little is gained in heat recovery.)

1 KW	Temperature Rise					
	80	90	100	110	120	130
Gallons Per Hour	5.2	4.6	4.1	3.8	3.5	3.2

# RESIDENTIAL GAS AND ELECTRIC WATER HEATER SERVICE HANDBOOK

## Residential Electric – continued

Since the element (s) are - very nearly - totally immersed in the tank, thermal efficiency is assumed to be 100%. – all of the Btu (Watts) generated, enter the water.



A.



B.



C.

- **Watt Density** = the density of the wattage output of the element compared to the surface area of the element (i.e. “High Watt Density Element” will have the most wattage per square inch of element surface. If the above elements generated 4,500 w. each, “B” might be considered a “high” watt density element, “A” a medium and “C” a low.)

- **Voltage Notes:**

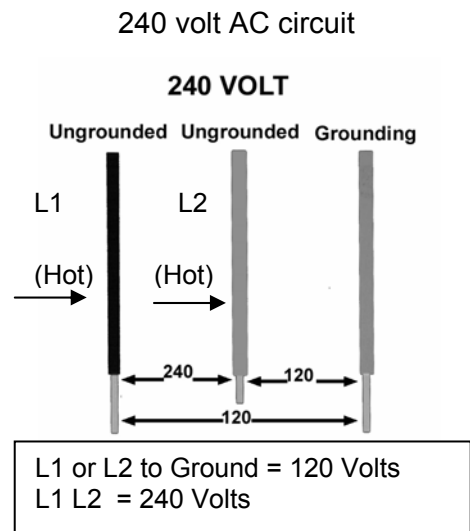
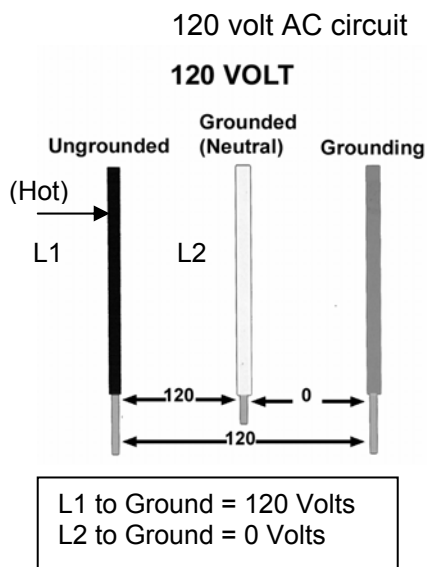

# RESIDENTIAL GAS AND ELECTRIC WATER HEATER SERVICE HANDBOOK

## Residential Electric – continued

### Surface Mounted Thermostat (s) and High Limit (s)

The thermostats and high limits are held against the side of the tank. As the tank surface heats or cools, a metal disc inside of the control expands or contracts to open or close electrical contacts in the controls.

They will satisfy within 10°F of setting. The tank surface has to cool 8 - 15°F to reactivate these controls.

Model	Circuit	Older Models	Newer Models <sup>1</sup>	Location	Temperature Range °F
<sup>2</sup> 59T-Style 4100	A-6, A-7	X A-6		Upper Tank	110-170
<sup>2</sup> 59T-Style 4000	A-6, A-7, C-2	X	X	Lower Tank	110-170
<sup>3</sup> 89T33	A-6		X	Upper Tank	90-150
<sup>3</sup> 89T13	C-2, A-7		X	Lower Tank	90-150
<sup>2</sup> 59T-Style 4000	A-6		X	Lower Tank	90-150
<sup>2</sup> AW-Style 7135	A-7	X	X	Upper Tank	110-170
<sup>4</sup> 66T-Style 4400	A-6, A-7, C-2	X	X	Lower Tank	190°
<sup>3</sup> 89T	A-6, A-7, C-2		X		170°

<sup>1</sup>"Older" = series 916 or older.

"Newer" = series 917 or more current – (Began approximately January, 1996)

<sup>2</sup>Older 59T controls had a maximum setting of 170°F. Replacement 59T controls will stop at 150°F.

<sup>3</sup>89T controls are combination High Limit/Thermostat, one piece controls.

<sup>4</sup>66T limits may be mounted onto 59T thermostats.

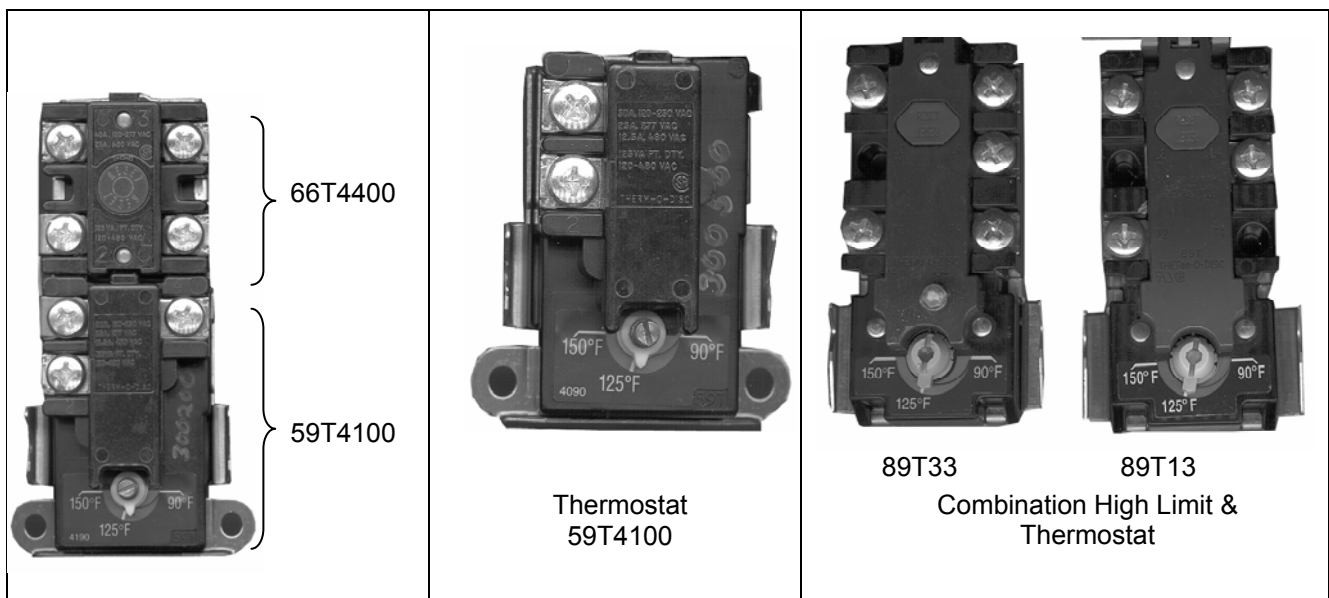

# RESIDENTIAL GAS AND ELECTRIC WATER HEATER SERVICE HANDBOOK

## Residential Electric – continued

After having confirmed that the water heater has been installed per the installation manual instructions:

### C-2 Circuit

- Single element
- Single thermostat
- Single High Limit

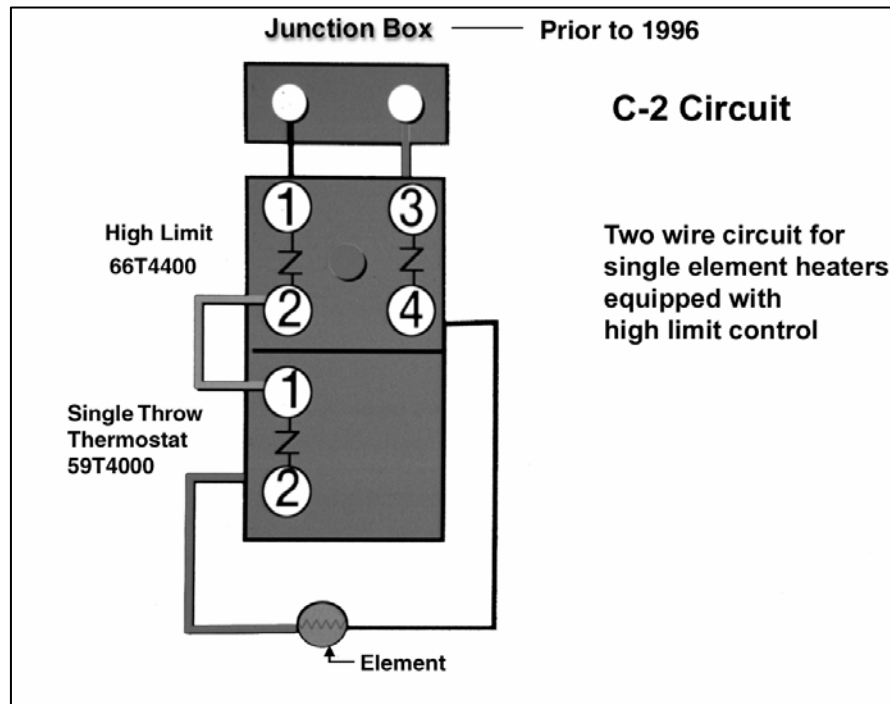
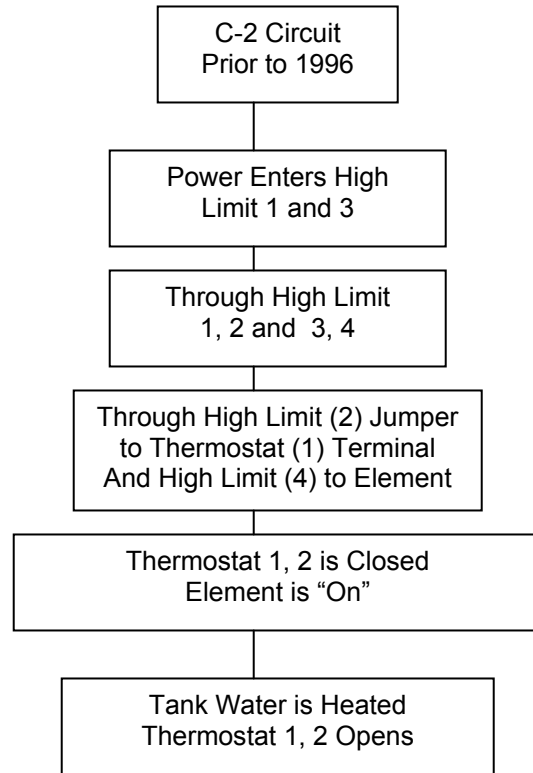



# RESIDENTIAL GAS AND ELECTRIC WATER HEATER SERVICE HANDBOOK

## Residential Electric – continued

### Normal Sequence of Operation

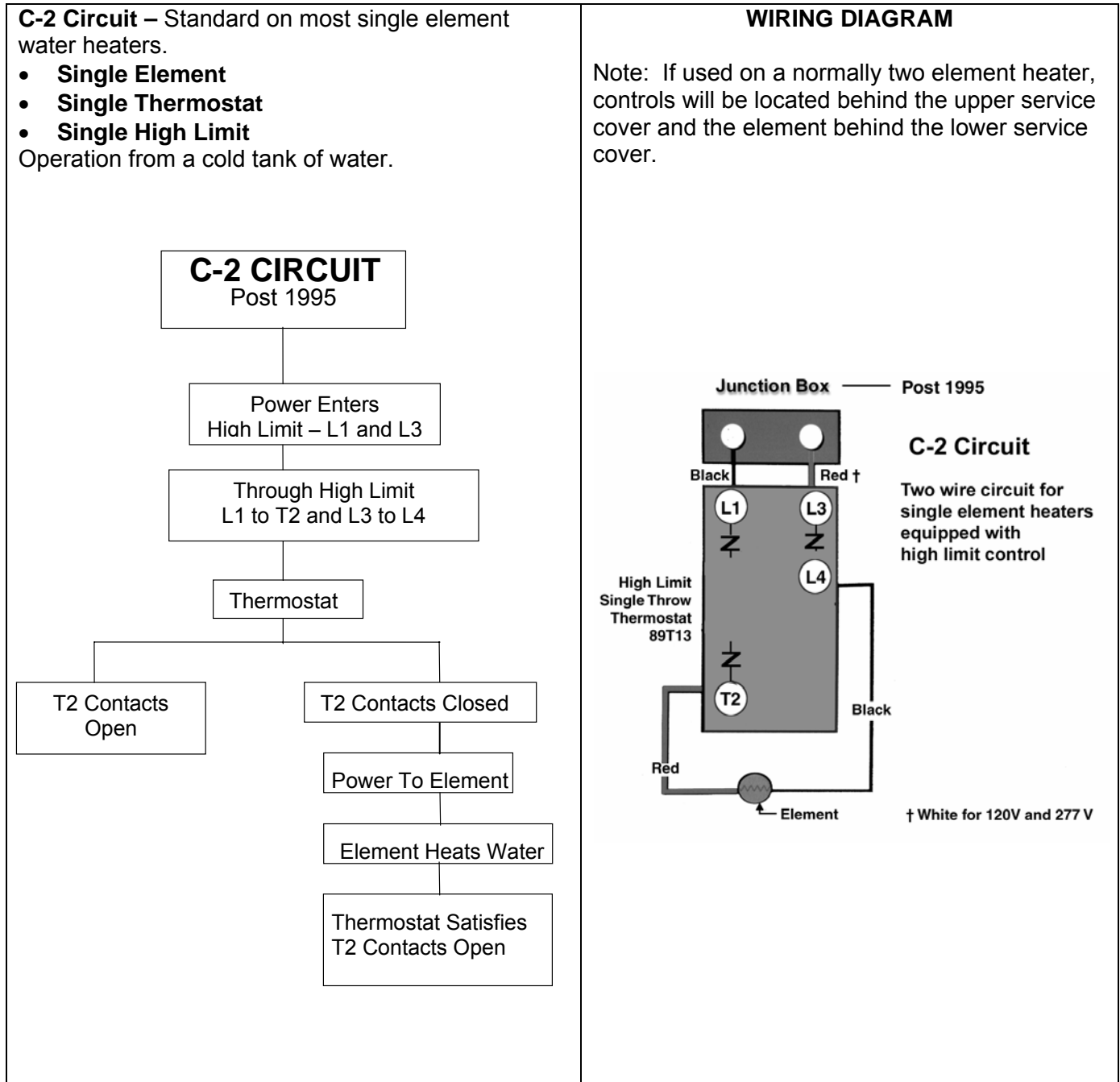

# RESIDENTIAL GAS AND ELECTRIC WATER HEATER SERVICE HANDBOOK

## Residential Electric – continued

### A-6 Circuit

- 2 Elements
- 2 Thermostats
- 1 High Limit

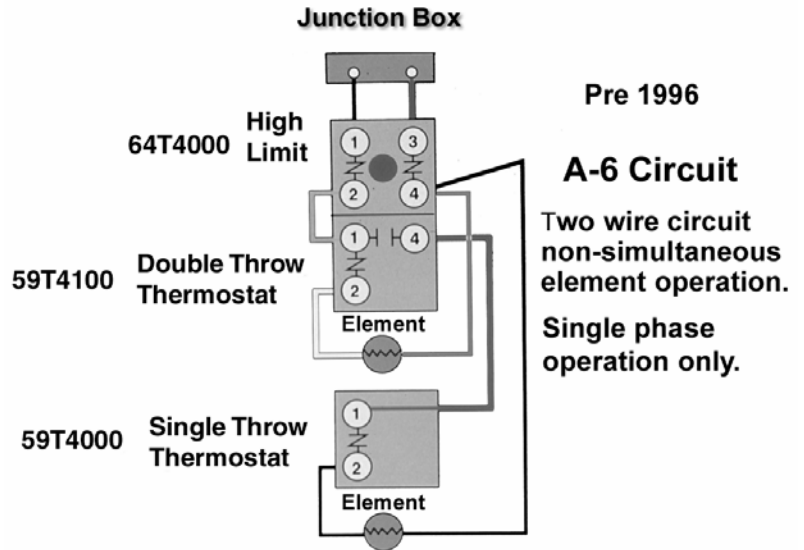

### Operation: From cold tank of water

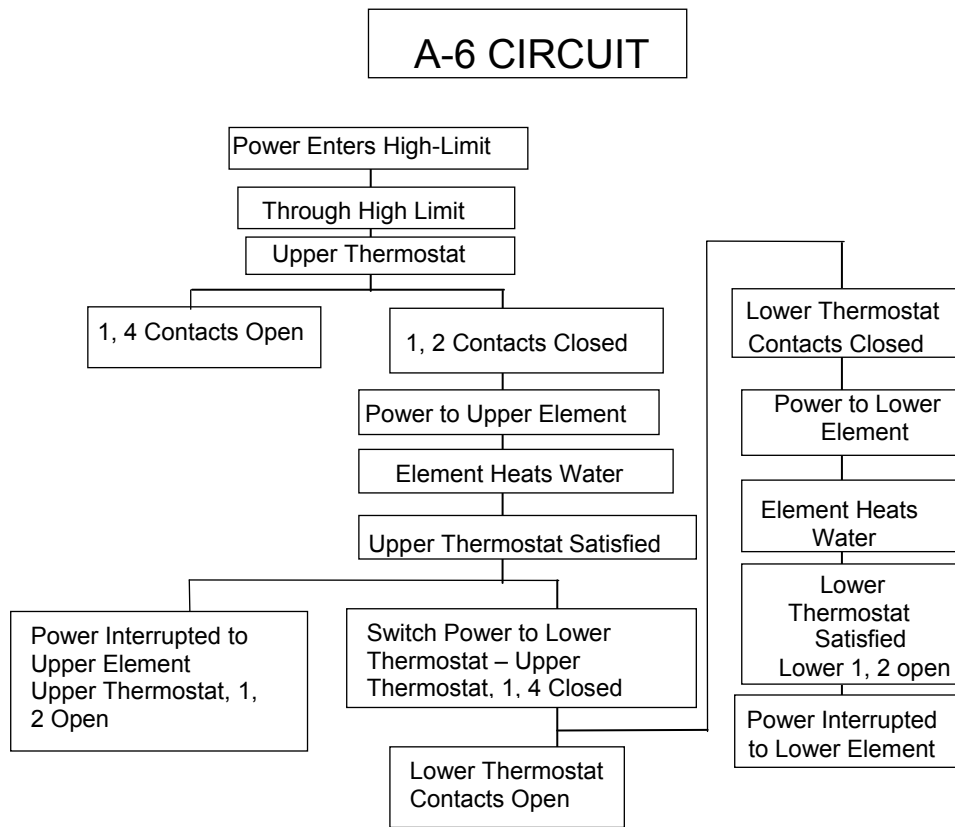

# RESIDENTIAL GAS AND ELECTRIC WATER HEATER SERVICE HANDBOOK

Residential Electric – continued

## WIRING DIAGRAM

### A-6 Circuit

- 2 Elements
- 2 Thermostats
- 1 High Limit

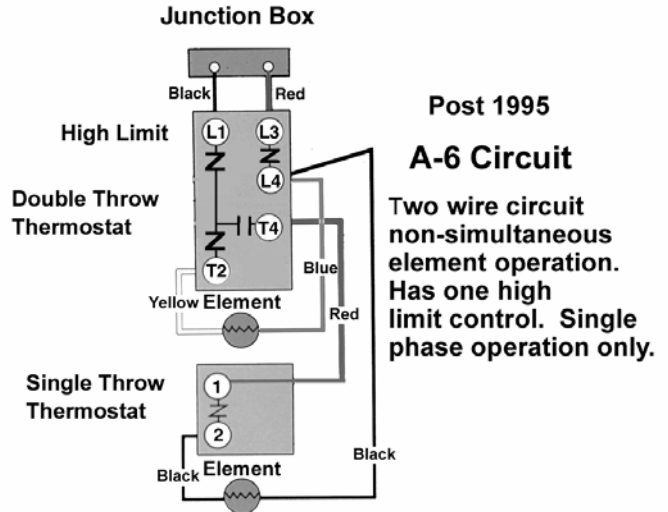

**A-6 Circuit** - Standard on dual element water heaters non-simultaneous/interlocked operation.

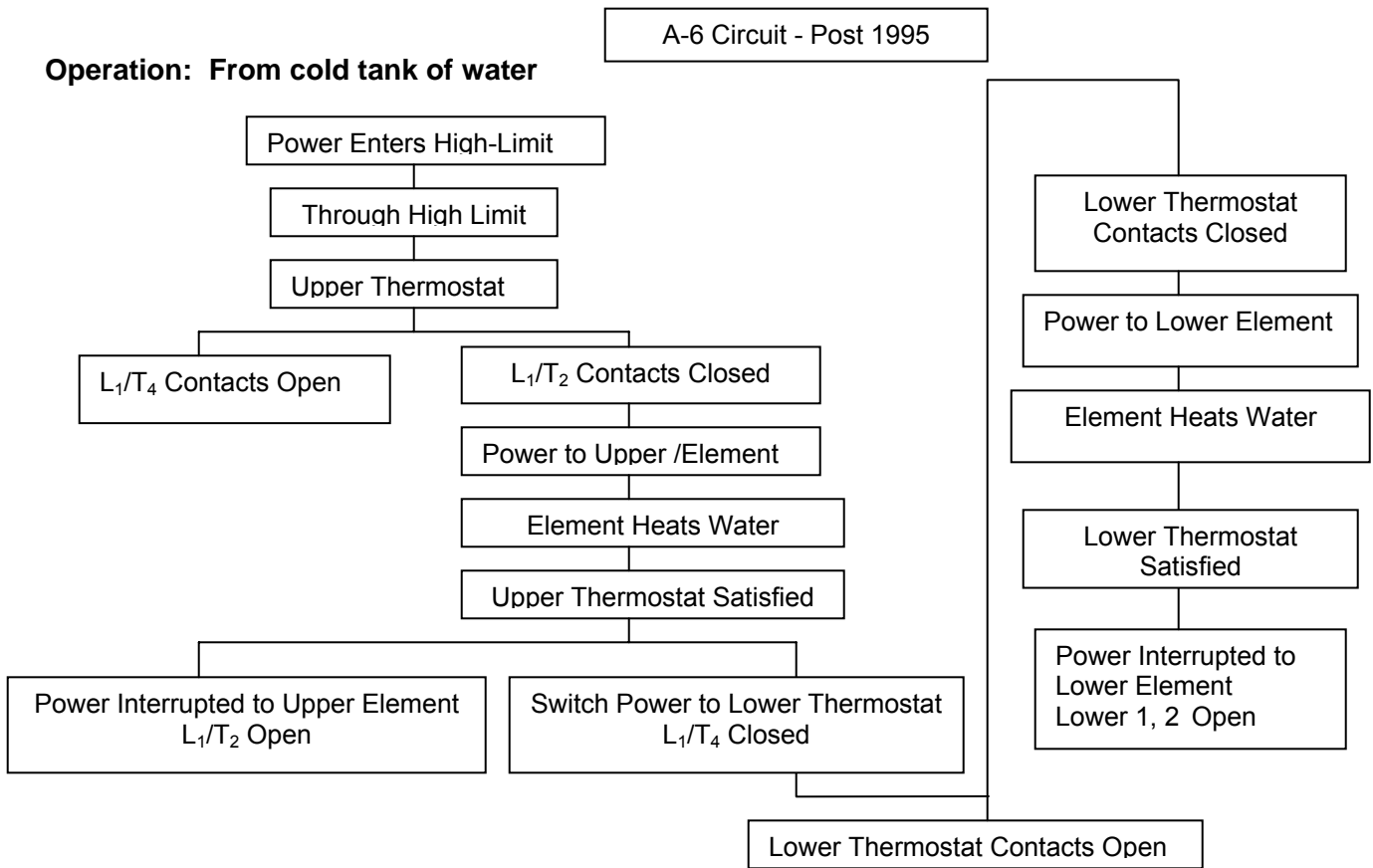

# RESIDENTIAL GAS AND ELECTRIC WATER HEATER SERVICE HANDBOOK

## Residential Electric – continued

### A-7 Circuit

- 2 Elements
- 2 Thermostats
- 2 High Limits
- 4 wire

### A-7

Four wire circuit non-simultaneous operation.

This circuit permits off peak meter usage. Prior to 1996

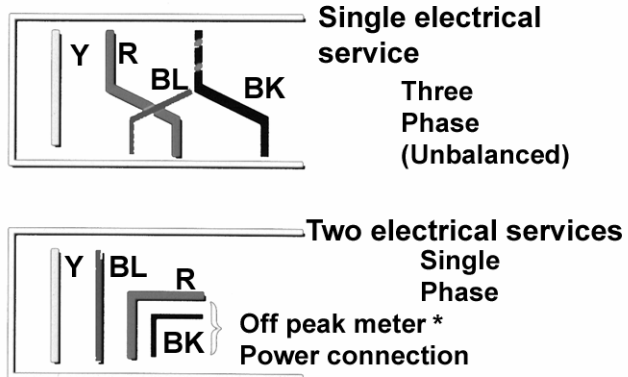

\*Some electrical utilities give discounts if electricity is used during “Off Peak” times of the day. This circuit allows use of an “Off Peak” meter, which interrupts power to the lower element during the time of day when electricity is more expensive. This customer relies on additional hot water storage to meet their needs while this element is off.

### Prior to 1996

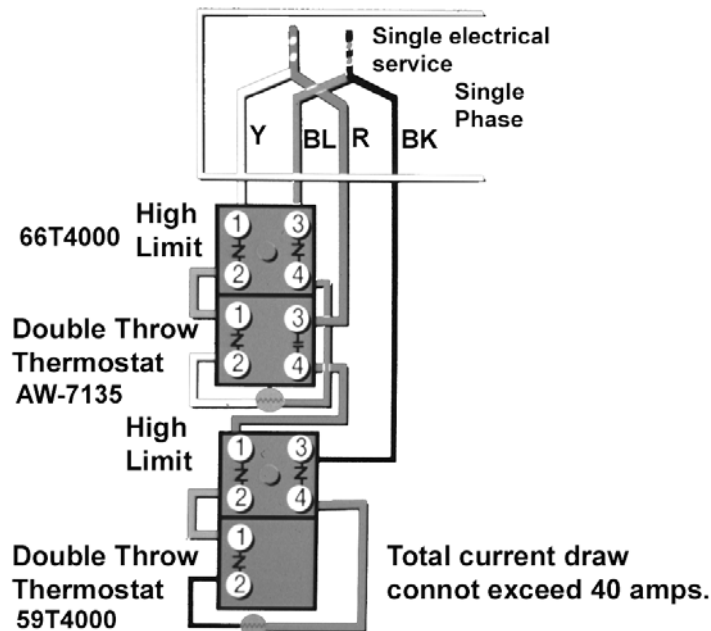

# RESIDENTIAL GAS AND ELECTRIC WATER HEATER SERVICE HANDBOOK

## Residential Electric – continued

Cold tank of water

- Single Electrical Service
- Single Phase

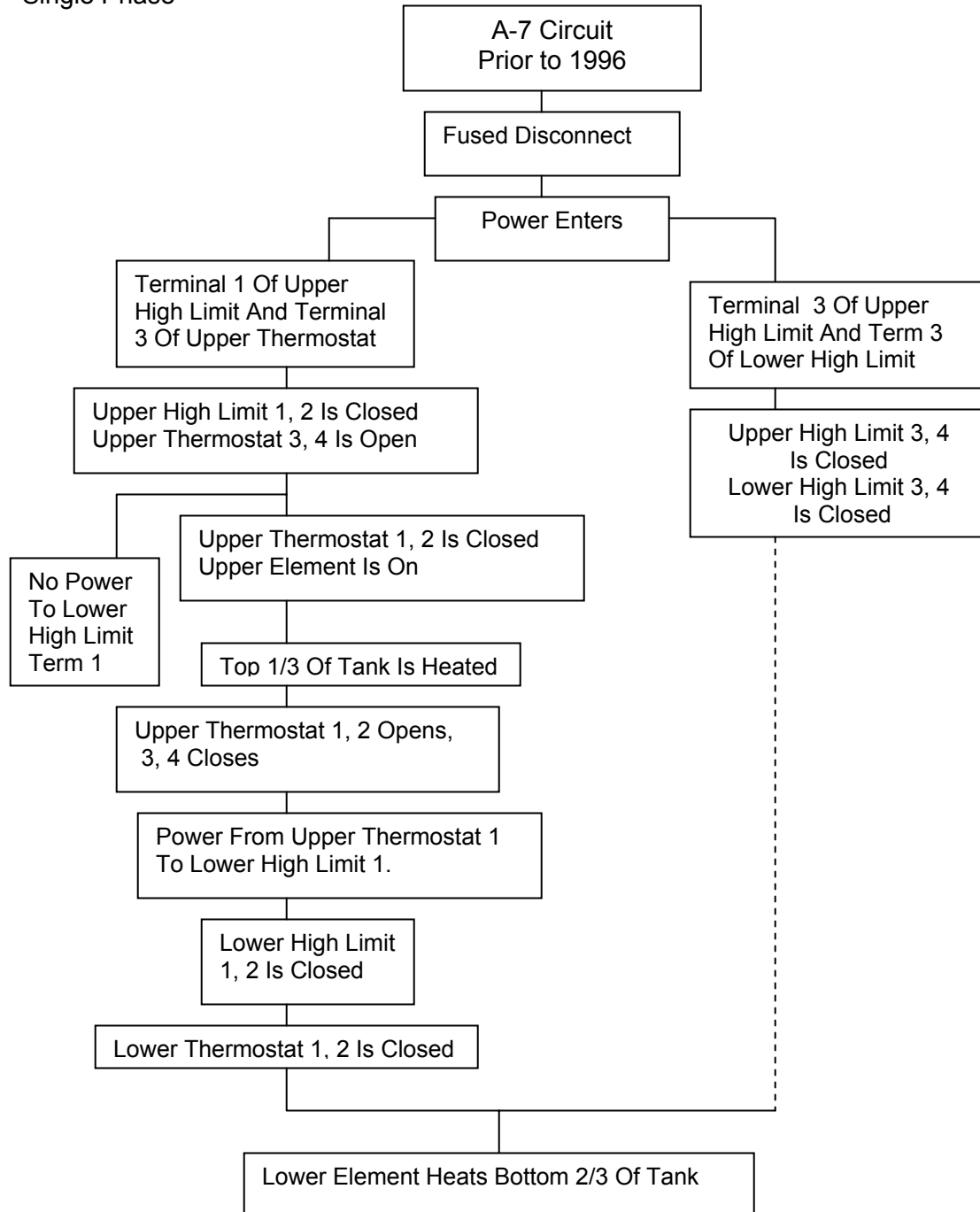

# RESIDENTIAL GAS AND ELECTRIC WATER HEATER SERVICE HANDBOOK

## Residential Electric – continued

### A-7 Circuit

- 2 Elements
- 2 Thermostats
- 2 High Limits
- 4 Wire

## WIRING DIAGRAM

### A-7 – Post 1995

Four wire circuit for non-simultaneous element operation.  
This circuit permits off-peak meter usage and connection to 3 phase supply circuit.

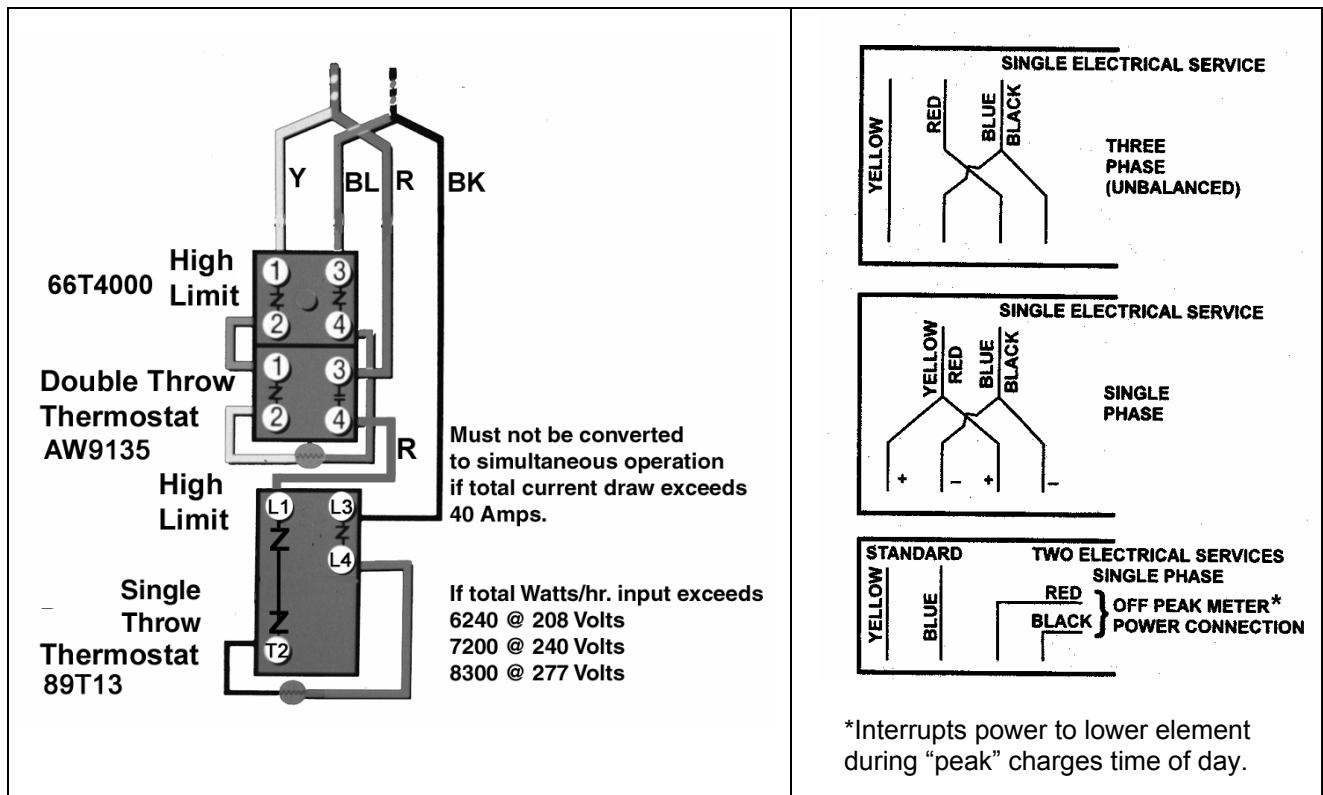

# RESIDENTIAL GAS AND ELECTRIC WATER HEATER SERVICE HANDBOOK

## Residential Electric – continued

Cold tank of water

- Single Electrical Service
- Single Phase

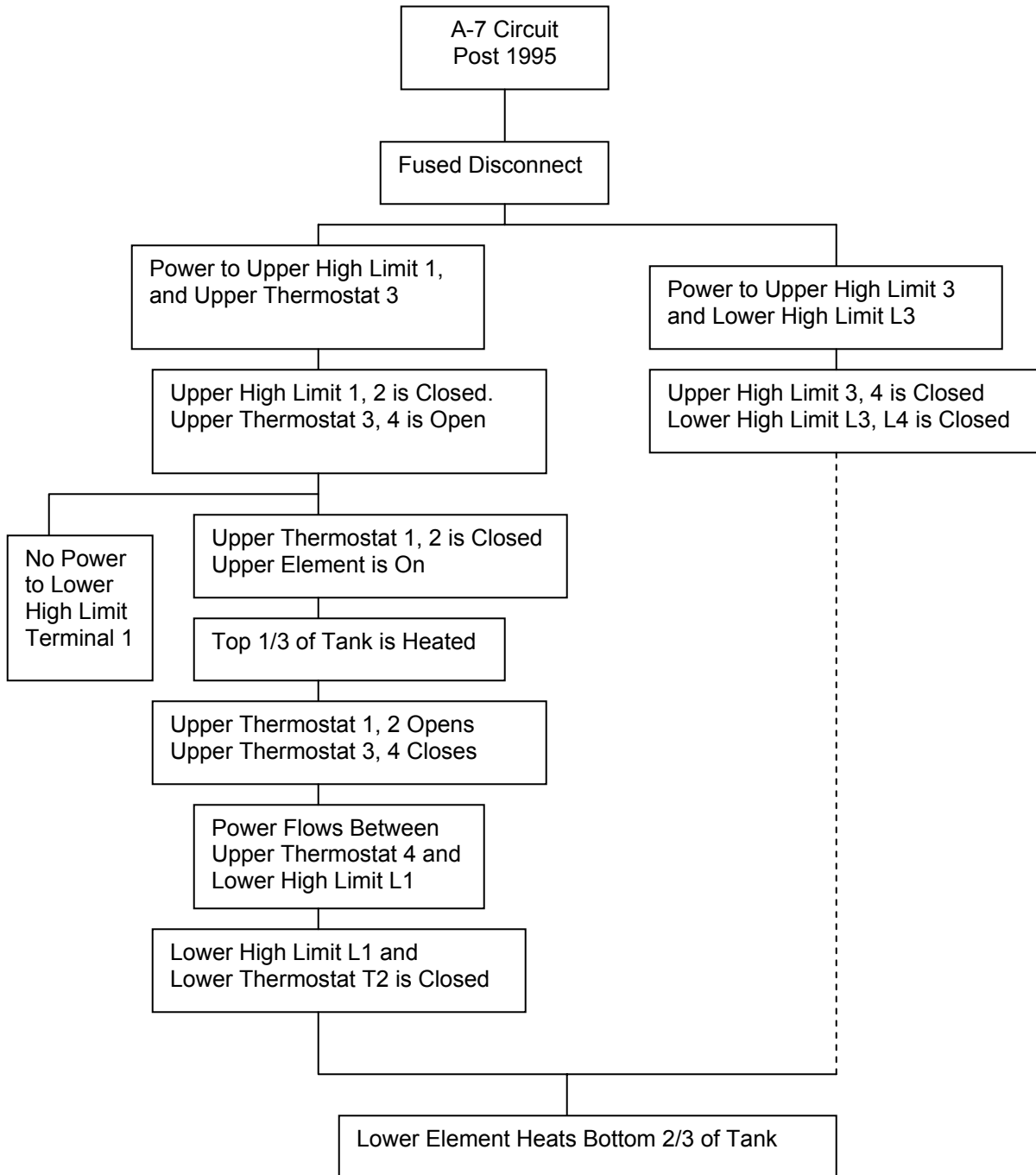

# RESIDENTIAL GAS AND ELECTRIC WATER HEATER SERVICE HANDBOOK

---

## Residential Electric – continued

### CERTIFICATION AND APPROVALS

UL – UL-174 applies to Residential Electric Water Heaters

The following paragraph describes the relationship between ASHRAE, NAECA and the Department of Energy's ENERGY FACTOR as it relates to the residential electric product line. All of the A.O. Smith residential electric water heaters meet this code.

The American Society of Heating, Refrigeration and Air Conditioning Engineer (ASHRAE) guidelines follow the National Appliance Energy Conservationist Act (NAECA). NAECA follows the Department of Energy (DOE) test procedures of the 1990 code of federal regulation, title 10, part 430 (64) which establishes minimum Energy Factors (EF) for water heaters of 12 kilowatts or less and a storage capacity of at least 20, but not more than 120 gallons.

Formula (as of January 2004) -The minimum EF allowed =  $.97 - .00132 \times V$  (volume of storage)  
Example (EES-52; 50 gal.  $\times .00132 = .066$  Then  $.97 - .066 = .904$  minimum allowable energy factor).



# RESIDENTIAL GAS AND ELECTRIC WATER HEATER SERVICE HANDBOOK

Residential Electric – continued

## Three Phase – Unbalanced Circuit

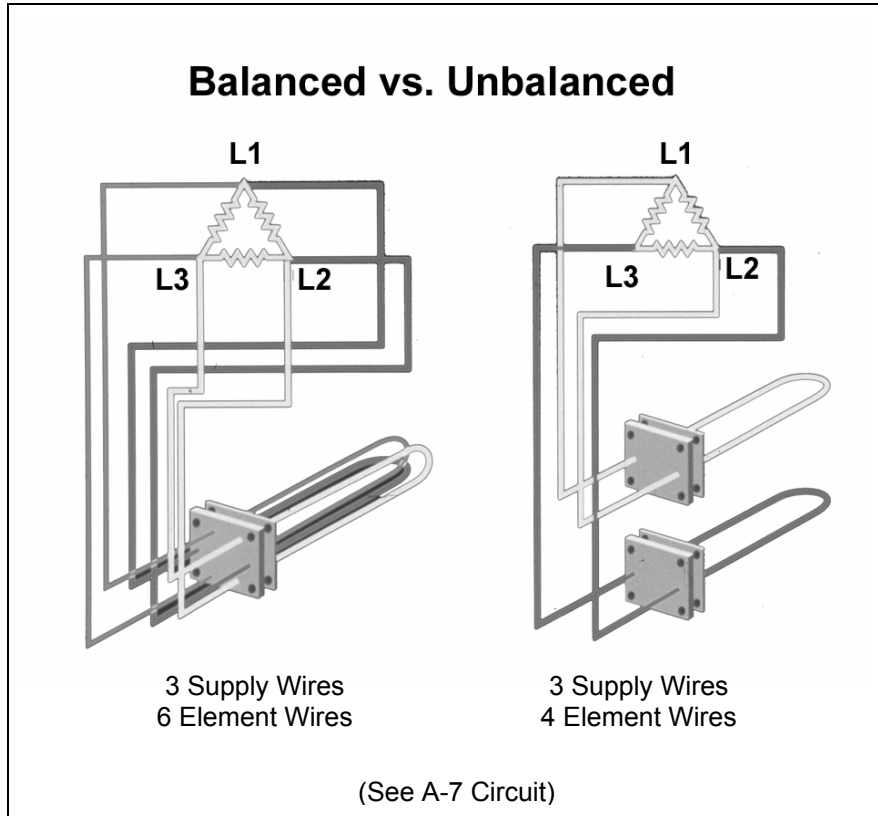

<b>SIMULTANEOUS DUAL ELEMENTS</b> (both elements 'on' when entire tank is cold)			
Element Wattage Upper/Lower	Full Load Current in Amperes Connected to Three Phase Power (Terminal L2/ Terminals L1 & L3)		
	208V	240V	480V
3000/3000	25.0/14.4	21.7/12.5	10.8/6.3
4000/4000	33.3/19.2	28.9/16.7	14.4/8.3
4500/4500	37.5/21.6	32.5/18.8	16.2/9.4
5000/5000	N/A	36.1/20.8	18.0/10.4
6000/6000	N/A	N/A	21.7/12.5

**Note:** Residential heaters may or may not offer the ability to wire elements for simultaneous operation. If they are wired for non-simultaneous operation, amperage will be as if wired single phase.

# RESIDENTIAL GAS AND ELECTRIC WATER HEATER SERVICE HANDBOOK

Residential Electric – continued

## SERVICE

### Testing C-2 type – single element, single controls type circuit

#### Element Test

#### OHMS Resistance Check\*\*

#### Test Conditions:

This test uses the multimeter's battery as the electrical supply.

#### Procedures:

Power to the water heater is "OFF".

Multimeter set to OHMS scale testing.

Black lead "Common" port.

Red lead in "Ω" or "OHMS" port.

Dial indicator set to scale above expected indication.

Note: Volts divided by amps = OHMS

Disconnect wires from the element terminals.

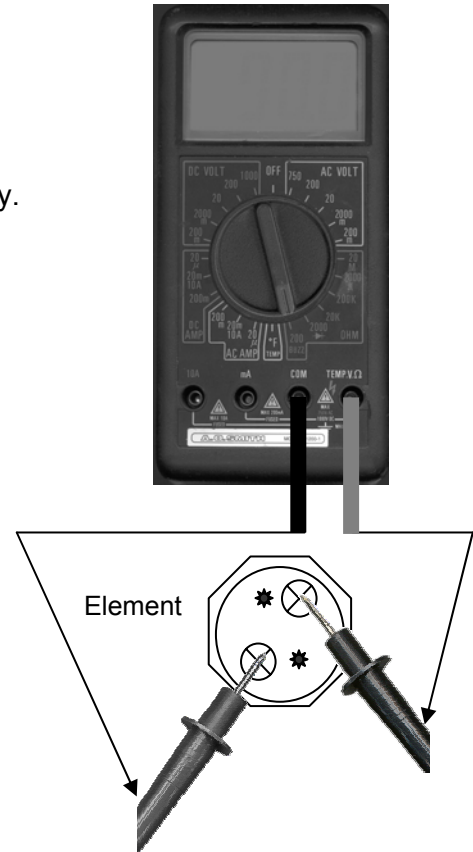

#### Test probe on each terminal of an element

See OHMS Resistance Table – Page 45

If ...	... then
proper resistance (+7.5%) is present	continue testing.
meter reads "0"	<ul style="list-style-type: none"><li>• check OHM scale setting.</li><li>• replace element</li></ul>
meter reads "1" or off scale	replace element.

\*\* The above test can also be conducted with the element removed from the tank.

# RESIDENTIAL GAS AND ELECTRIC WATER HEATER SERVICE HANDBOOK

## Residential Electric – continued

### C-2 – service continued

**Complaint:** No Hot Water

**Conditions:** Tank water cold  
Power on

**Procedure:** Multimeter set for  
AC voltage check

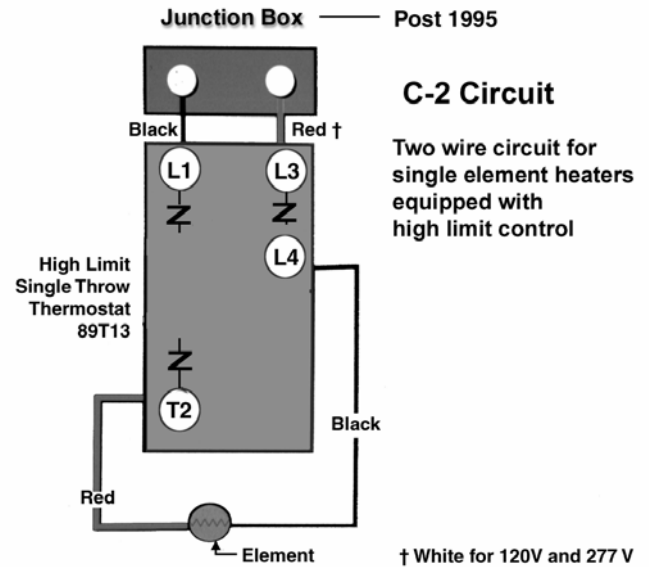

## Voltage Checks

### Test voltage between 1 and 3 or L1 and L3 of high limit.

If ...	... then
rated voltage is not present	<ul style="list-style-type: none"> <li>• check circuit breaker (fused disconnect)</li> <li>• check wire connections in heater junction box</li> <li>• check position of heater ON/OFF switch-if applicable.</li> </ul>
rated voltage is present	continue to next step.

### Test voltage between 2 and 4 or L1 and L4 of high limit

If ...	... then
rated voltage is not present	<ul style="list-style-type: none"> <li>• press high limit reset button</li> <li>• replace high limit (after conducting thermostat check)</li> </ul>
rated voltage is present	continue to next step.

### Test voltage between 4 and 2 or T2 and L4

If ...	... then
rated voltage is not present	<ul style="list-style-type: none"> <li>• check jumper between high limit 2 and thermostat 1or</li> <li>• on T2, L4 test-replace control.</li> </ul>
rated voltage is present	continue to next step.

# RESIDENTIAL GAS AND ELECTRIC WATER HEATER SERVICE HANDBOOK

Residential Electric – continued  
C-2 service “No Hot Water” – continued

## Test between the two element terminals

If ...	... then
rated voltage is not present	check wiring from control.
rated voltage is present	<ul style="list-style-type: none"> <li>repeat Ohms resistance test of element</li> <li>check for water leaks in piping or fixtures.</li> </ul>

## Complaint: Water Too Hot

### Conditions:

Tank water above thermostat setting +10°F  
Power on

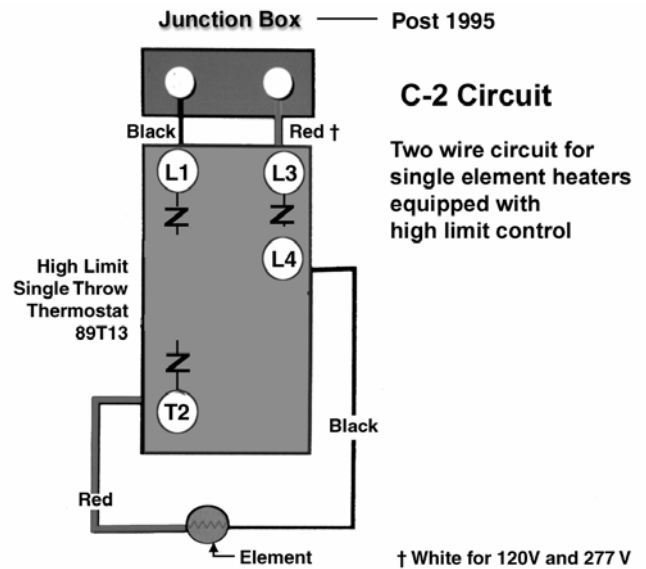

## Voltage Check

### Test between 4 and 2 or L4 and T2

If ...	... then
rated voltage is present	replace thermostat control.
lower than rated voltage is present	test for grounded element.
no voltage is present	test complete.

# RESIDENTIAL GAS AND ELECTRIC WATER HEATER SERVICE HANDBOOK

Residential Electric – continued  
C-2 – service “Water Too Hot” – continued

## Grounded Element Check – Amperage Method

**Grounded Element Test – using “clamp type” Amperage Meter.** Many multimeters could be used to conduct this test but be certain that possible amperage will not exceed the multimeter’s limit.

**Complaint:** A grounded element is suspected whenever the water temperature becomes **excessively hot** and/or the end user **must push the high limit reset** to reactivate the heater.

**Amperage** measures the flow of current through a wire.  
**Watts** divided by volts = Amps

### Conditions:

Power on  
Thermostat is satisfied

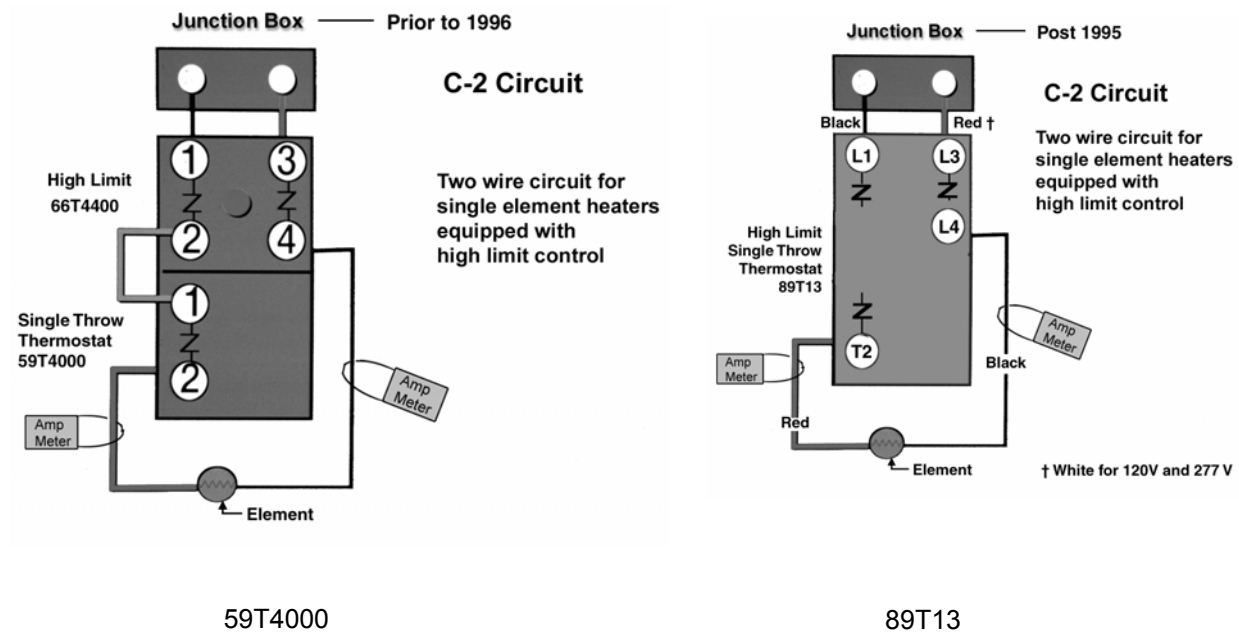

**Test around red wire then black wire to element.**

If ...	... then
amperage is noted (indicating flowing power)	replace the element.
amperage is not noted	the element is not grounded.

# RESIDENTIAL GAS AND ELECTRIC WATER HEATER SERVICE HANDBOOK

## Residential Electric – continued

### A-6 Circuit Servicing

Testing A-6 - two element, two thermostat, one high limit, two wire circuit type water heaters.

Wired non-simultaneously – When the upper element satisfies, power switches to the lower thermostat and element.

#### Element Test

#### OHMS Resistance Check\*\*

##### Test Conditions:

This test uses the multimeter's battery as the electrical supply.

Power to the water heater is "OFF".

Multimeter set to OHMS scale testing.

Black lead "Common" port.

Red lead in "Ω" or "OHMS" port.

Dial indicator set to scale above expected indication.

Note: Volts divided by amps = OHMS

Disconnect wires from the element terminals.

#### Test probe on each terminal of an element

See OHMS Resistance Table – Page 45

If ...	... then
proper resistance (+7.5%) is present	continue testing.
meter reads "0"	<ul style="list-style-type: none"> <li>• check OHM scale setting.</li> <li>• replace element.</li> </ul>
meter reads "1" or off scale	replace element.

\*\* The above test can also be conducted with the element removed from the tank.

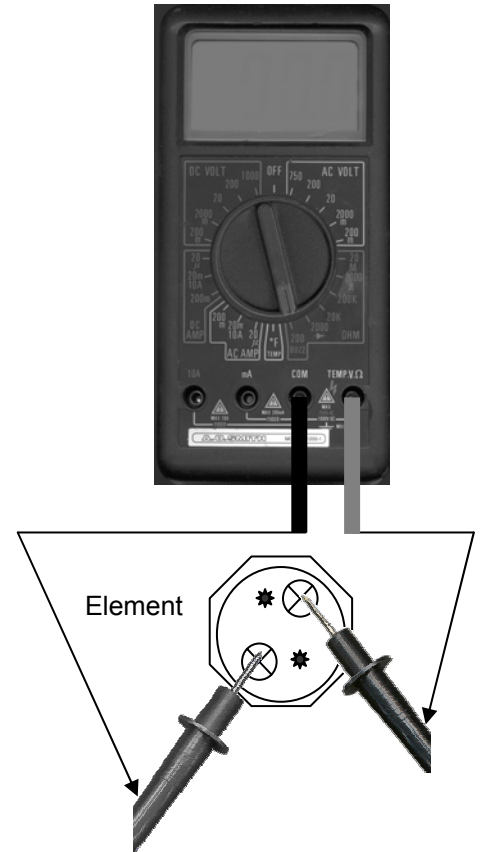

# RESIDENTIAL GAS AND ELECTRIC WATER HEATER SERVICE HANDBOOK

## Residential Electric – continued A-6 service – continued

### Testing with the Multimeter

Probes installed to test for "voltage - (black test lead is "common".)  
Dial set to AC - Voltage scale - set dial to highest voltage scale or scale above the expected voltage. Do not set the meter to a scale below the voltage expected.

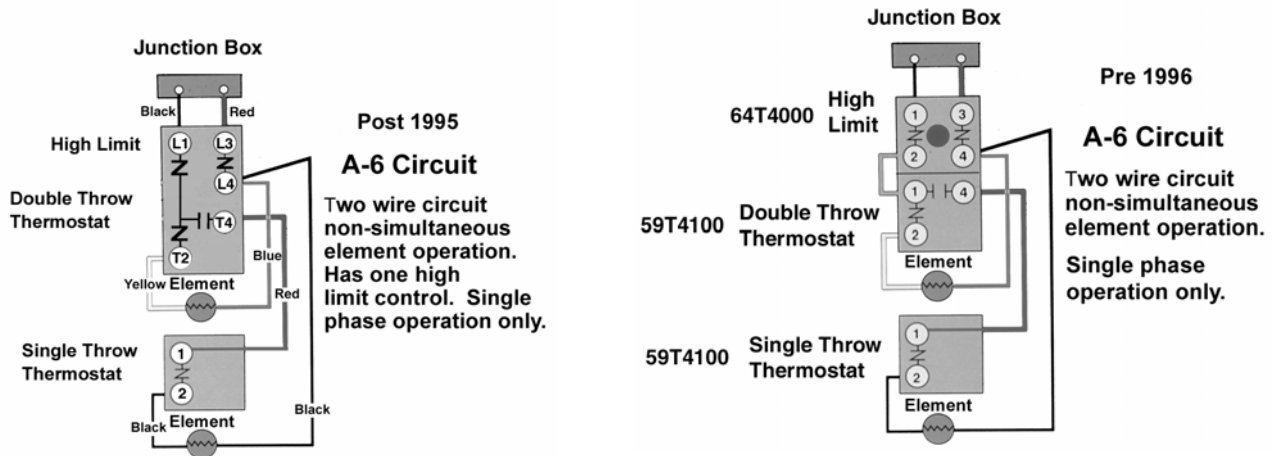

**Complaint:** No hot water

**Test Conditions:**

Tank is full of cold water.  
Power is "on" to the heater

### Voltage Check

#### Test between 1 and 3 or L1 and L3

If ...	... then
correct supply voltage is present	continue.
correct supply voltage is NOT present	<ul style="list-style-type: none"> <li>• check disconnect breaker.</li> <li>• check wiring to the heater.</li> </ul>

#### Test between 2 and 4 or L1 and L4

If ...	... then
correct supply voltage is present	continue
correct supply voltage is NOT present,	push Manual Reset - if power is now supplied, conduct thermostat and element checks.
still no power	replace High Limit (High Limit/Thermostat on 89T)

# RESIDENTIAL GAS AND ELECTRIC WATER HEATER SERVICE HANDBOOK

---

## Residential Electric – continued

### A-6 service Voltage Check “No Hot Water” – continued

#### Test between Thermostat 2 and High Limit 4 or T2 and L4

If ...	... then
supply voltage is present:	continue.
supply voltage is not present	<ul style="list-style-type: none"><li>• check jumper between high limit 2 and thermostat 1.</li><li>• replace thermostat – (tank must be 15°F cooler than setting to activate thermostat.</li></ul>

#### Complaint: Lack of Hot Water

##### Conditions:

Upper thermostat satisfied

Lower portion of tank still calling for heat

#### Test between high limit 4 and thermostat 4 and L4 and T4

If ...	... then
correct supply voltage is present	continue.
correct supply voltage is not present	<ul style="list-style-type: none"><li>• check that tank water temp has satisfied the upper thermostat.</li><li>• replace the upper thermostat.</li></ul>

#### Test between high limit 4 and lower thermostat 1 or L4 and 1

If ...	... then
correct supply voltage is present	continue.
correct supply voltage is not present	check wiring connections.

#### Test between high limit 4 and lower thermostat 2 or L4 and 2

If ...	... then
correct supply voltage is present	continue.
correct supply voltage is not present	replace lower thermostat.



# RESIDENTIAL GAS AND ELECTRIC WATER HEATER SERVICE HANDBOOK

## Residential Electric – continued A-6 service – continued

**Grounded Element Test – Amperage Method - using “clamp type” Amperage Meter.** Many multimeters could be used to conduct this test but be certain that the amperage limits of the multimeter will not be exceeded.

**Complaint:** A grounded element is suspected whenever the water temperature becomes **excessively hot** and/or the end user **must push the high limit reset** to reactivate the heater.

**Amperage** measures the flow of current through a wire.

**Watts** divided by volts = Amps

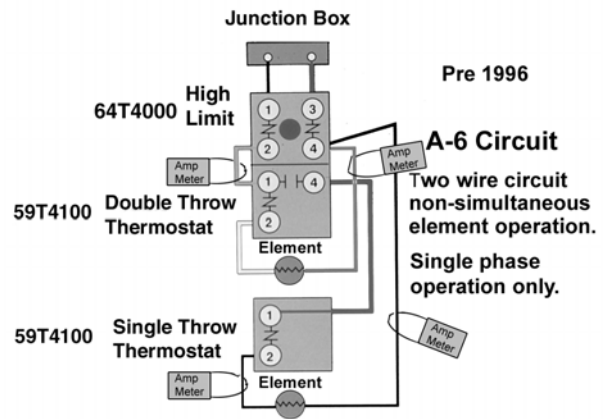
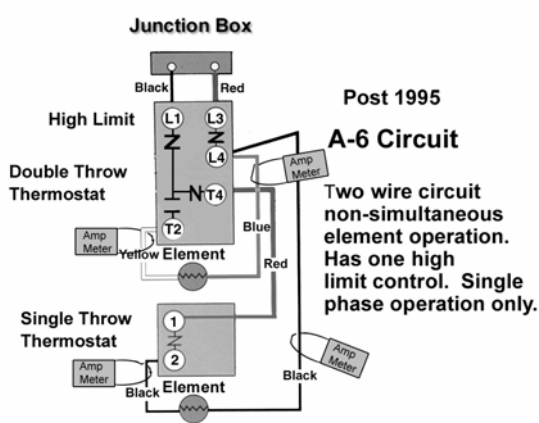

## Test Conditions

Wires on the water heater are all connected to their proper terminals.

Power to the heater is "on".

Both thermostats are satisfied.

**Clamp the jaws of the Amp Meter around each wire connected to the elements – one wire at a time.**

If ...	... then
meter reads the proper amperage (+5, - 10%)	the thermostat is calling for heat.
meter reads approximately ½ of the proper amperage	replace the element.
meter reads NO amperage	thermostat and element are not grounded.

# RESIDENTIAL GAS AND ELECTRIC WATER HEATER SERVICE HANDBOOK

## Residential Electric – continued

### Testing The A-7 Wiring Circuit

#### A-7 Circuit:

- Two elements
- Two thermostats
- Two high limits
- Four wires
- Non-simultaneous operation or simultaneous

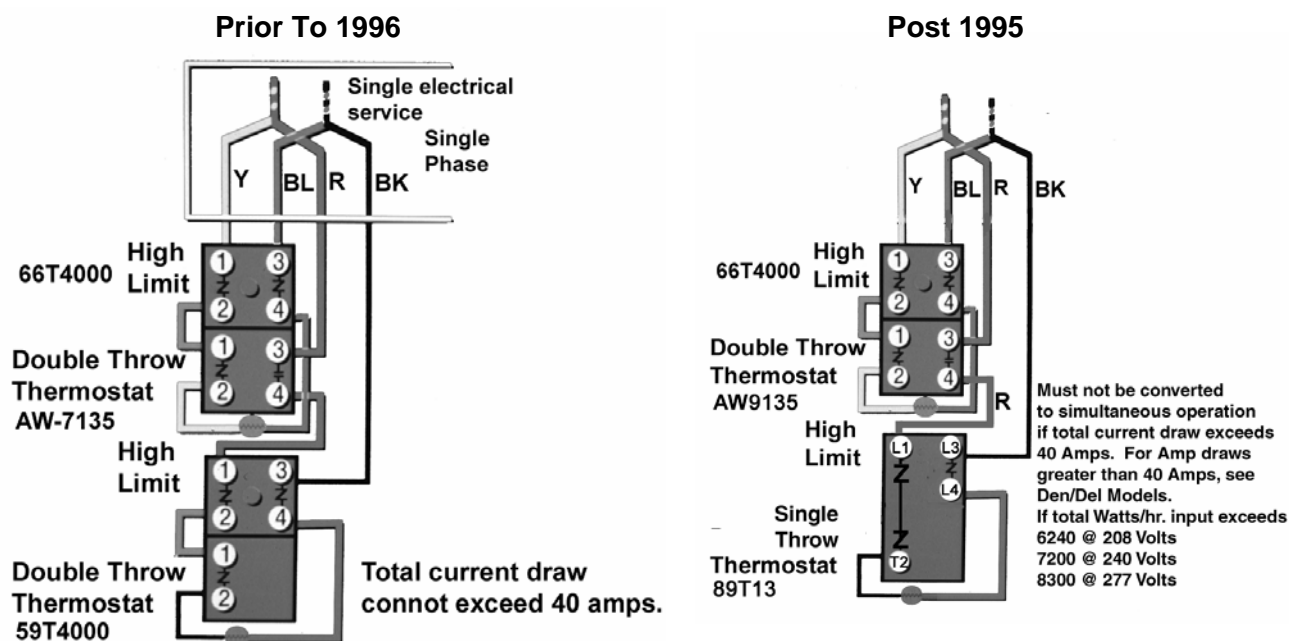

#### Supply wiring may be a: (See Pages 34 and 37)

1. three wire, 3 phase circuit:
2. two wire, single phase circuit or
3. connection to an off peak meter or time clock.

This third, wiring system interrupts power to the lower thermostat during the designated time period but does not interrupt power to the upper thermostat.

If the consumer uses enough of the stored hot water to drop tank temperature at the top of the tank to call for upper element activation, then the upper element will reheat the upper third of the tank

# RESIDENTIAL GAS AND ELECTRIC WATER HEATER SERVICE HANDBOOK

**Residential Electric – continued**  
**A-7 Service – continued**

## Element Test

### OHMS Resistance Check\*\*

**Test Conditions:**

Element(s) not heating or water becoming excessively hot.  
This test uses the multimeter's battery as the electrical supply.

**Procedure:**

Power to the water heater is "OFF".  
Multimeter set to OHMS scale testing.  
Black lead "Common" port.  
Red lead in "Ω" or " OHMS" port.  
Dial indicator set to scale above expected indication.  
Note: Volts divided by amps = OHMS

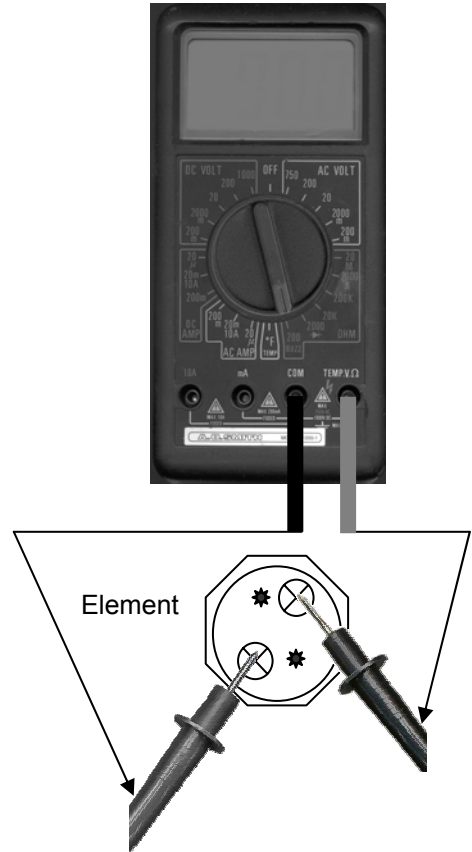

Disconnect wires from the element terminals.  
See OHMS Resistance Table – Page 52

**Test probe on each terminal of an element**

If ...	... then
proper resistance (+7.5%) is present	continue testing.
meter reads "0"	<ul style="list-style-type: none"> <li>• check OHM scale setting</li> <li>• replace element.</li> </ul>
meter reads "1" or off scale	replace element.

\*\* The above test can also be conducted with the element removed from the tank.

# RESIDENTIAL GAS AND ELECTRIC WATER HEATER SERVICE HANDBOOK

---

## Residential Electric – continued A-7 Voltage Check

### Voltage Checks

These tests are conducted on the heater, below the junction box.

**Complaint:**                      **No Hot Water**

#### Test Conditions:

Tank is full of cold water (or at least 15°F below the upper thermostat setting).

#### Power on

Upper thermostat calling for heat

Multimeter set to the proper AC voltage scale

#### Test between upper high limit terminals 1 and 3

If ...	... then
the proper voltage is not present (disconnect)	check power from the breaker (fused disconnect).
the proper voltage is present	check wiring in heater junction box continue to next step.

#### Test between upper high limit terminals 2 and 4

If ...	... then
the proper voltage is not present	push the reset button – if this establishes proper voltage, conduct thermostat and element checks before changing the high limit.
pushing the reset does not restore voltage	replace the high limit.
the proper voltage is present	continue to the next step.

#### Test between upper high limit 4 and upper thermostat 2

If ...	... then
the proper voltage is not present high limit and upper thermostats 2	<ul style="list-style-type: none"><li>• check the jumper between upper thermostat 1 and high limit 2.</li><li>• replace the upper thermostat</li></ul>
the proper voltage is present	<ul style="list-style-type: none"><li>• conduct upper element checks.</li><li>• top 1/3 of tank should be hot.</li></ul>

# RESIDENTIAL GAS AND ELECTRIC WATER HEATER SERVICE HANDBOOK

Residential Electric – continued  
A-7 Voltage Check - continued

**Complaint:** Lack of Hot Water

**Test Conditions:**  
Upper thermostat satisfied

**Test between upper high limit 4 and upper thermostat 4**

If ...	... then
proper voltage is not present	replace upper thermostat.
proper voltage is present	continue to next step.

**Test between lower high limit terminal 1 and 3 or L1 and L3**

If ...	... then
proper voltage is not present	<ul style="list-style-type: none"> <li>check wiring to upper thermostat and heater junction box.</li> <li>check that off peak meter is not "Open".</li> </ul>
proper voltage is present	continue to next step.

**Test between lower high limit 2 and 4 or L1 and L4**

If ...	... then
proper voltage is not present	push lower high limit reset.
pushing reset restored voltage	<ul style="list-style-type: none"> <li>conduct lower thermostat check</li> <li>conduct lower element checks</li> </ul>
pushing reset did not restore voltage	replace lower high limit
proper voltage is present	continue to next step

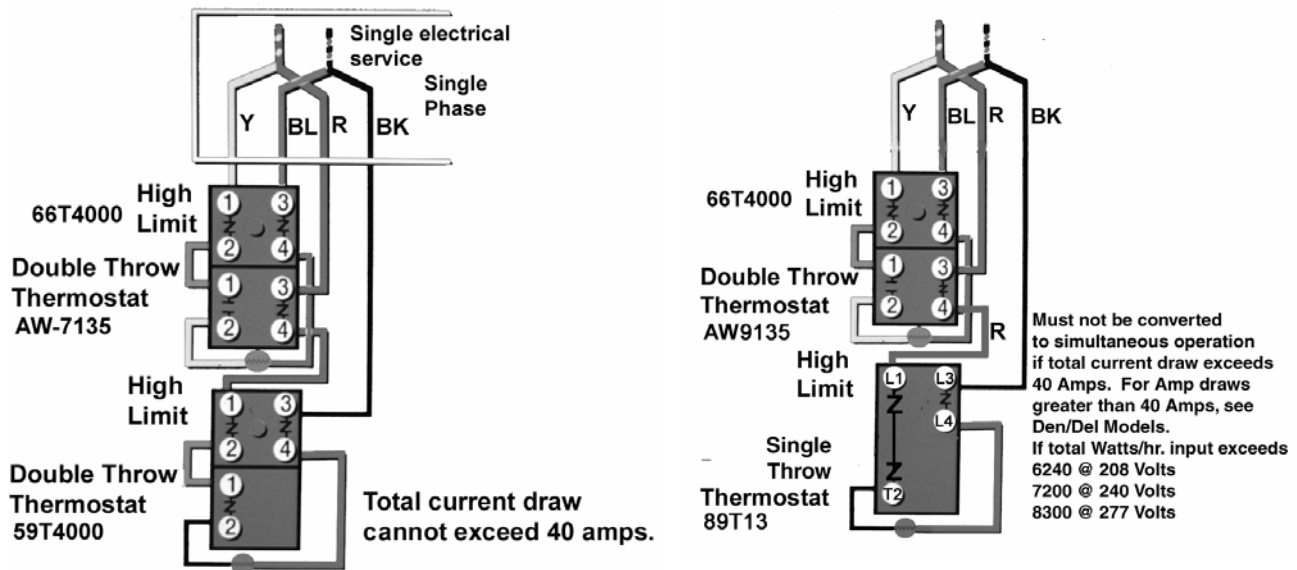

# RESIDENTIAL GAS AND ELECTRIC WATER HEATER SERVICE HANDBOOK

## Residential Electric – continued

### A-7 service – Voltage Checks “Lack of Hot Water” – continued

#### Test Condition

Lower tank water is at least 15°F below lower thermostat setting

#### Test between lower high limit 4 and lower thermostat 2 or lower high limit L4 and lower thermostat T2

If ...	... then
proper voltage is not present:	<ul style="list-style-type: none"> <li>check jumper between lower high limit 2 and lower thermostat 1.</li> <li>replace lower thermostat.</li> </ul>
proper voltage is present:	continue to next step.

#### Test between the terminals of the lower element

If ...	... then
proper voltage is not present:	check wire connections to lower controls.
proper voltage is present:	conduct grounded element checks.

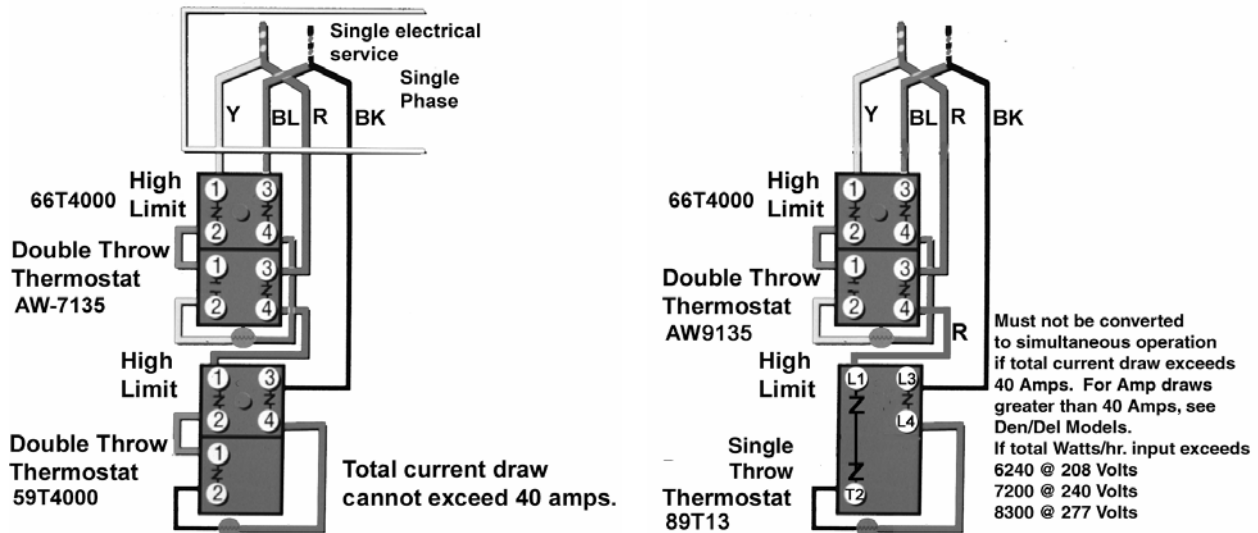

# RESIDENTIAL GAS AND ELECTRIC WATER HEATER SERVICE HANDBOOK

## Residential Electric – continued A-7 – continued

**Grounded Element Test – Amperage Method – Using “clamp type” Amperage Meter.** Many multimeters could be used to conduct this test but be certain that the thermostat is satisfied or the amperage limits of the multimeter may be exceeded.

**Complaint:** A grounded element is suspected whenever the water temperature becomes **excessively hot** and/or the end user **must push the high limit reset** to reactivate the heater.

**Amperage** measures the flow of current through a wire.  
**Watts** divided by volts = Amps

### Conditions

Power on  
Thermostats are satisfied

**Clamp the jaws of the Amp Meter around each wire connected to an element – one wire at a time.**

If ...	... then
meter reads the proper amperage (+5, -10%)	the thermostat is calling for heat
meter reads approximately ½ of the proper amperage	replace the element
meter reads NO amperage	thermostat and element are not grounded

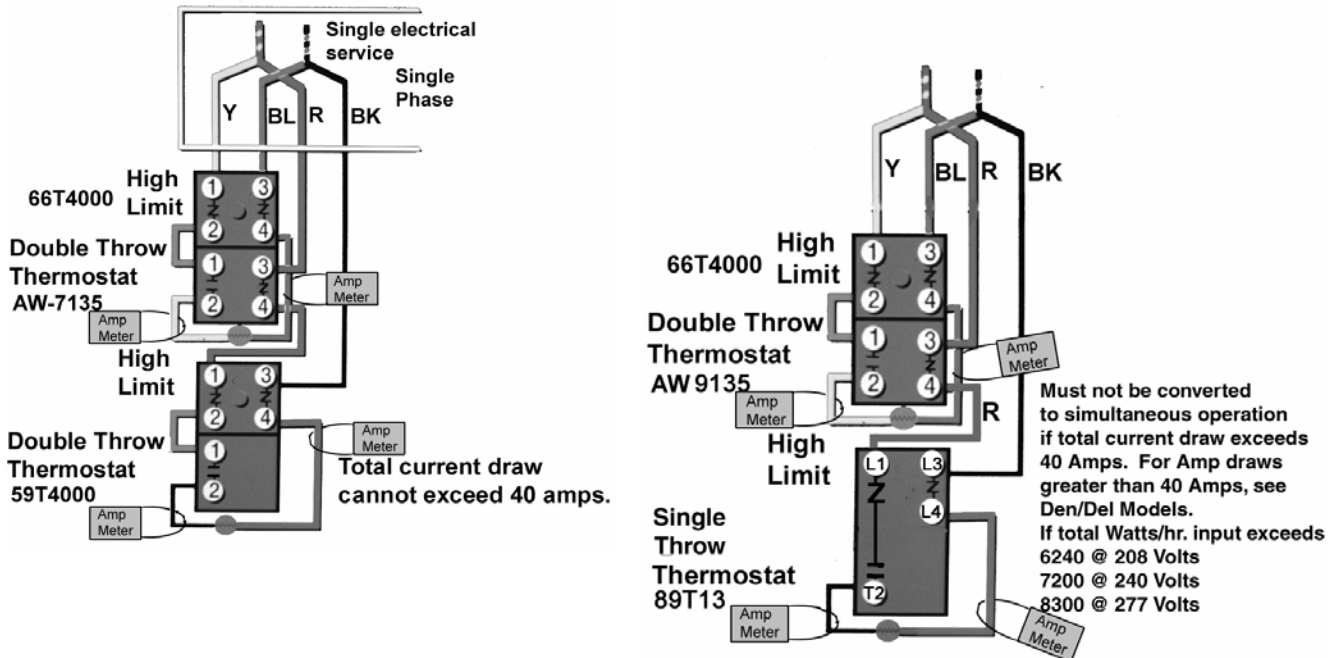

Note: Amperage will only be indicated while electricity flows through a wire.

## RESIDENTIAL GAS AND ELECTRIC WATER HEATER SERVICE HANDBOOK

---

### Miscellaneous Residential Electric Water Heater Service Items:

- **Watts divided by Volts = Amps**  
Supply wire gauge and fuse (breaker) protection must be at least 125% of the expected Amperage draw of the water heater.
- **Volts times Amps = Watts**  
Replace elements with elements rated at the same wattage and voltage indicated on the heater model and rating plate. Installing an element with a **higher** voltage rating or wattage output may create a safety hazard by overloading the heater wiring or supply wiring or fusing. Installing an element with a **lower** wattage or voltage rating will reduce performance.
- Normally, a residential electric water heater with two elements will have **only one** element operate at a time. If the upper element or thermostat fails, the customer will be out of hot water. If the lower element or thermostat fails, the customer **should still** have 1/3 of the tank with hot water.
- With two element heaters, the **lower element and thermostat** will **cycle more** frequently than the upper element and thermostat. For this reason, the lower element will normally accumulate lime faster and fail more often than the upper element. Lower thermostats will fail more often than upper thermostats.
- **Replacement elements:**  
Replace elements with an element having the **most surface area** (low watt density) available for your water heater. By spreading the heat of the element over a greater area, lime (calcium) buildup rate should be reduced.  
Elements constructed of **Incoloy** are much more durable than elements made of copper with zinc coating.
- Many electric **utilities** offer discounts if you do not use electricity during certain times of the day. **Contact them** – by purchasing a larger storage water heater, with special wiring (see A-7 wiring circuit) for time clocks or “off peak meters”, you may save on monthly operating costs.

Element with Links							
Resistance of Element in Ohms (± 7.5%)							
Rated Voltage	Rated Wattage						
	600	750	1000	1250	1500	2000	2500
120	23.2	18.6	13.9	11.1	9.28	6.96	5.57
208	72.1	57.7	43.3	34.6	28.8	21.6	17.3
240	92.8	74.3	55.7	44.6	37.1	27.8	22.3
277	128	102	76.7	61.4	51.2	38.4	30.7
Rated Voltage	Rated Wattage						
	3000	3500	4000	4500	5000	5500	6000
120	4.64						
208	14.4	12.4	10.8	9.61	8.65	7.85*	7.2
240	18.6	15.9	13.9	12.4	11.1	10.1*	9.28
277	25.6	21.9	19.2	17.1	15.3	14.0	12.8
480	76.8	65.7	57.5	51.1	45.7	41.8	38.4



# RESIDENTIAL GAS AND ELECTRIC WATER HEATER SERVICE HANDBOOK

---

## A.O. SMITH TECHNICAL BULLETINS

The following are bulletins designed to help service the standard, residential gas and electric model water heaters. These bulletins and more are available on the A. O. Smith website [www.aosmithwaterheaters.com](http://www.aosmithwaterheaters.com).

This information is intended to supplement service and maintenance information found in the heater installation and operation manual.

“Why water heaters leak” information .....54-55

### Index of Technical Bulletins:

Water Hammer .....	56
Mineral Buildup .....	57
Aluminum Hydroxide .....	58
Discolored Water .....	59
Smelly Water .....	60
Chlorination Procedure.....	61
Not Enough Hot Water - Gas .....	62
Not Enough Hot Water – Electric .....	63
Thermal Expansion.....	64-65
Leaking Temperature and Pressure Relief Valve .....	66

## RESIDENTIAL GAS AND ELECTRIC WATER HEATER SERVICE HANDBOOK

---

### WHY WATER HEATER TANKS LEAK

WHAT	WHY	PREVENTION
Water Pressure	Water expands when it is heated (Thermal Expansion). Water cannot be compressed. Excessive Pressure in the tank causes failure of joints, welds or gaskets.	A Temperature and Pressure Relief Valve limits pressure to a maximum. Adding a Thermal Expansion Tank limits pressure to near supply water pressure.
Condensation (Gas Water Heaters)	Products of combustion contain moisture. As the combustion products cool the moisture becomes liquid – carbonic acid. The acid attacks the metal. Higher efficiency water heaters have cooler gases. Recommended water storage temperatures create cooler surfaces.	Install a water heater with capacity to minimize significant stored water temperature drop during usage. Store water at a higher temperature – install a mixing valve to reduce danger of scalding.
Contaminated Air	Bleaches, floor waxes, detergents, salt and many other household products contain chemicals which, when drawn into contact with a flame (a gas water heater uses 12 cubic feet of air for each 1000 BTU of heat generated). When these chemical vapors or dusts come into contact with a flame or electrical contact, various acids form. These acids attack the metal.	Supply the heater with clean air. “Direct Vent” water heaters use air from outside of the building for combustion.
Soft Water	Soft water minimizes mineral buildup within the tank. Minimal minerals maintain the water heater at high efficiency but may also expose interior surfaces to corrosion. Mineral buildup in some heaters prevents them leaking while greatly reducing efficiency.	A metal “Anode” rod within the tank helps to prevent internal corrosion. Maintain the self sacrificing “anode” rod by inspecting the rod annually and replacing when large “gouges” appear in its surface.

## RESIDENTIAL GAS AND ELECTRIC WATER HEATER SERVICE HANDBOOK

**WHY WATER HEATER TANKS LEAK -**

**Continued**

<b>WATER CONDITIONS</b>		
<b>WHAT</b>	<b>WHY</b>	<b>PREVENTION</b>
"Hard" Water (Gas Water Heaters)	"Hard" water contains minerals. As water is heated the minerals separate from the water and attach to hot surfaces within the tank. In gas water heaters, these minerals "insulate" the heat transfer surfaces conducting heat from the burner through to the water. These surfaces become hotter than if they were clean. Hotter surfaces mean more expansion and contraction of the metal as the burner cycles on and off. The metal or weld joints crack.	"Flush" the sand from the tank every 6 months. Delime the tank interior yearly. Install a water softener in hard water areas. These should be adjusted according to manufacturer's recommendations, typically for 5 grains hardness.
"Hard" Water (Electric Water Heaters)	See above explanation. Lime (calcium) forms on the electric elements. Elements become excessively hot and may split. Split elements often leak to the outside of the heater.	Inspect and clean elements as necessary. Add a water softener. Install elements resistant to failure due to Lime (mineral) build up.
Water Temperature	Water stored at 160°F (72 °C) may be twice as corrosive as water stored at 140°F (60°C)	Begin with a water heater setting of 120°F (49°C) and increase only as necessary.
Usage	Each time the burner or elements cycle on and off, a small amount of metal expansion and contraction take place. As bending a piece of wire back and forth will break the wire, this expansion and contraction will eventually crack tank joints or welds.	Purchasing a proper sized tank will minimize burner or element operation when only small quantities of hot water are used.

For more detailed explanation on this information as well as additional service information, see the A.O. Smith Web site [www.hotwater.com](http://www.hotwater.com) under "Technical Information".

0801 form TC-063

# RESIDENTIAL GAS AND ELECTRIC WATER HEATER SERVICE HANDBOOK



A DIVISION OF A. O. SMITH CORPORATION



## TECHNICAL BULLETIN

BULLETIN 11

### WATER HAMMER

<b>GENERAL</b>	Water hammer is the destructive forces, pounding noises and vibration in a piping system when water flowing through a pipeline is stopped abruptly. When water hammer occurs, a high intensity pressure wave travels back through the piping system until it reaches a point of some relief. The shock wave will then surge back and forth between the point of relief and the point of stoppage until the destructive energy is dissipated in the piping system. The violent action accounts for “banging”, “thumping”, and/or intense vibration in the pipe line. Although noise is generally associated with the occurrence of water hammer, it can occur without audible sound or noise. Quick closure always causes some degree of shock with or without noise. The common cause of water hammer is single lever faucets (sinks/lavatories) or automatic solenoid valves (dishwashers, washing machines, etc.). The speed of the valve closure time is directly related to the intensity of the surge pressure.
<b>EFFECTS</b>	The damage from water hammer can manifest itself in a number of ways. The most common are: <ul style="list-style-type: none"><li>• <i>Expanded Tank Shell</i> - This can be demonstrated by measuring the circumference at various locations along the shell. Pressures in excess of the maximum design working pressure can cause permanent deformation of the shell.</li><li>• <i>Collapsed Flue Tube</i> - This will choke off the ability to vent the products of combustion causing the flame and/or combustion to spill out from the combustion chamber. Often this will occur where thinning of the flue tube walls has occurred due to contamination of the combustion air or because of excessive condensation.</li><li>• <i>Inverted or Deformed Tank Heads</i> - Often this accompanies collapsed flues, but one or both heads can be deformed.</li></ul>
<b>THE FIX</b>	The only effective means of control is to install water hammer arrestors. These devices have diaphragms, which separate an air chamber from the water in the piping system. As the shock wave reaches this device, the air chamber absorbs the shock. Arrestors should be located as close as possible to the source of the shock wave.
<b>NOTES</b>	Since water hammer exposes the equipment to pressures in excess of its design limits, failures caused by water hammer are not eligible for warranty consideration.

# RESIDENTIAL GAS AND ELECTRIC WATER HEATER SERVICE HANDBOOK

**A.O. SMITH**  
**WATER PRODUCTS**  
**COMPANY**

A DIVISION OF A. O. SMITH CORPORATION



## TECHNICAL BULLETIN

BULLETIN 13

### MINERAL BUILD-UP

<b>SYMPTOMS</b>	<ul style="list-style-type: none"><li>• Rumbling</li><li>• Crackling</li><li>• Popping</li></ul>
<b>CAUSE</b>	<p>With the advent of high input and larger storage tanks in both commercial and residential heaters, deliming has become a necessity of modern maintenance. Lime (<math>\text{CaCO}_3</math>), is the most notable factor when discussing water hardness. Lime is present in every water system to some degree across the entire United States. Since lime is inversely soluble [the more you heat, the more lime comes out], higher usage, excessive hardness, and increased heating surface can lead to a high incidence of “limed-up” heaters.</p> <p>Symptoms often include a popping of water trapped under lime deposits or the sizzling of water trapped next to elements, boiling it to steam.</p>
<b>THE FIX</b>	<p>Treatment of a “limed-up” heater is relatively simple. Since <math>\text{CaCO}_3</math> is a base, the easiest way to dissolve it so it can be flushed from the heater is with an acid. The most commonly used is phosphoric acid at a food-grade level.</p> <p>Two common treatments marketed by A.O. Smith are Mag-Erad® and Un-Lime®. Any well-stocked plumbing supply house should have a deliming solution available.</p> <p>The directions on the product should be followed explicitly.</p>
<b>NOTES</b>	<p>For additional information and instructions in deliming water heaters and boilers, please refer to the following pamphlets available from A.O. Smith:</p> <ul style="list-style-type: none"><li>• <i>Why? When &amp; How: To Remove Water Scale from Tank Type Water Heaters</i></li><li>• <i>The Mag-Erad® Method of Cleaning Gas Fired Water Heaters</i></li><li>• <i>Up-N-Down™ Transfer Kit</i></li><li>• <i>All About Deliming Coil Type Water Heaters</i></li></ul>

# RESIDENTIAL GAS AND ELECTRIC WATER HEATER SERVICE HANDBOOK

**A. O. SMITH**  
**WATER PRODUCTS**  
**COMPANY**

## TECHNICAL BULLETIN

BULLETIN 14

A DIVISION OF A. O. SMITH CORPORATION



### ALUMINUM HYDROXIDE

<b>SYMPTOMS</b>	“Crackling”, “gurgling”, or “popping” noises from new water heaters (installed less than six months).
-----------------	---

<b>CAUSE</b>	In a few isolated parts of the United States where the water supply has a relatively high pH (8+), water conditions will react with the aluminum anode to form excessive amounts of aluminum hydroxide on the anode and in the bottom of the tank. Aluminum hydroxide looks like “jelly beads” or a green, blue or gray gel like substance in the heater drain or at faucet aerators.
--------------	---

<b>THE FIX</b>	This procedure should only be performed by someone with abilities equal to a licensed tradesman. Aluminum hydroxide can be removed by using one of the methods outlined.
----------------	--

	<b>If tank is new <u>with no</u> lime build-up to any degree:</b>
1	Turn off the heater.
2	Remove the anode.
3	Flush the tank thoroughly with water.
4	Replace the aluminum anode ( <i>identifiable by smooth surface on plug</i> ) with magnesium anode ( <i>identifiable by weld bead on plug</i> ).
	<b>If the tank is new <u>with</u> lime build-up to any degree:</b>
1	Turn off the heater.
2	Drain the heater.
3	Remove the anode.
4	Add UN-LIME to the tank. 20-40 gallon models (use 3 gallons of UN-LIME) 41-65 gallon models (use 5 gallons of UN-LIME) 66-100 gallon models (use 7 gallons of UN-LIME) <i>(On electric models, be certain the lower element is immersed in solution.)</i>
5	Heat the UN-LIME to a temperature between 140°F to 160°F. <ul style="list-style-type: none"> <li>• GAS - Heat for 7 to 10 minutes.</li> <li>• ELECTRIC - Power off and remove the yellow wire from terminal 2 on the upper thermostat. Move the red wire from terminal 4 of the upper thermostat to terminal 2 of the upper thermostat. This allows operation of the lower element only. Restore power to the heater. Be certain that only the lower element is operating. Heat for 7 to 10 minutes.</li> </ul>
6	Shut off the water heater.
7	Allow the heated UN-LIME to stand for up to 12 minutes.
8	Drain and flush the tank. Caution: UN-LIME will still be hot.
9	Replace the original aluminum anode with a magnesium anode.
10	Fill the system with water.
11	On electric models, return the wiring to its original configuration.
12	Turn heater fuel “ON”.

<b>NOTE</b>	Since aluminum hydroxide is a product of a chemical reaction dependent on the water condition, any treatment is not considered warranty related.
-------------	--

# RESIDENTIAL GAS AND ELECTRIC WATER HEATER SERVICE HANDBOOK

**A.O. SMITH**  
**WATER PRODUCTS**  
**COMPANY**

A DIVISION OF A. O. SMITH CORPORATION



## TECHNICAL BULLETIN

BULLETIN 21

### DISCOLORED WATER

#### SYMPTOMS

Rusty, brown, black, or yellow water appearing in the hot water.

#### CAUSE

Complaints of discolored water are commonly blamed on water heaters and storage tanks, but in fact, it is a rare occurrence for today's high quality glass lined tanks to have a lining failure significant enough to allow water to contact enough bare metal to discolor the contents of even a small tank.

The most common cause of "rusty" water is a non-toxic iron reducing bacteria, scientifically termed Crenothrix, Leptothrix, and Gallionella. Iron bacteria is commonly found in soil, water wells, water treatment plants and water distribution piping systems where soluble iron exceeds 0.2 ppm, higher levels make conditions even more favorable. Soluble iron in the water provides food for the bacteria. Rusty discolored water is the end result of the bacteria feeding process. Water heaters and storage tanks usually require new anode rods as presence of iron bacteria contributes to premature anode failure.

The requirements for the bacteria to thrive are:

- Elevated level of iron and manganese in the water
- Water with little or no dissolved oxygen
- Temperatures below 138°F

Items that can increase the potential for this bacteria are:

- Water softeners
- Well water
- Long periods of no water movement

#### TREATMENT

The simplest treatment available is shock-chlorination of the system. This is a surface treatment, and often requires repeated trials in heavily infected systems. The chlorination of a system requires that you follow each step explicitly to avoid an un-treated portion of the piping system from reinfesting another part. See Bulletin 23 for the chlorination procedure.

#### NOTE

Since rusty water is caused by a bacteria presence and is not caused by the water heater, any treatment would not be considered warranty related.

# RESIDENTIAL GAS AND ELECTRIC WATER HEATER SERVICE HANDBOOK

**A.O. SMITH**  
**WATER PRODUCTS**  
**COMPANY**

A DIVISION OF A. O. SMITH CORPORATION



## TECHNICAL BULLETIN

BULLETIN 22

### SMELLY WATER

<b>CAUSE</b>	<p>The most common cause of “smelly water” is a non-toxic sulfate reducing bacteria, scientifically termed <i>Divibrio Sulfurcans</i>. This bacteria often enters the water system through construction or a break in ground piping. The bacteria creates the energy it needs to survive by converting sulfate (SO<sub>4</sub>) to hydrogen sulfide (H<sub>2</sub>S) gas you smell in the water.</p> <p>Hydrogen sulfide gas is distinctive because of its rotten egg-like stench. Its presence can severely affect the taste as well as the odor of the water. Occasionally this bacteria can be accompanied by black deposits, the result of pipe and fitting corrosion. In extremely high concentrations, hydrogen sulfide gas can be toxic though the gas is detectable long before harmful levels are reached.</p> <p>The requirements for the bacteria to thrive are: a) an elevated level of sulfur in the water, b) activated hydrogen from cathodic reactions within the tank, c) water with little or no dissolved oxygen, d) and temperatures below 138°F.</p> <p>Items that can increase the potential for this bacteria are: a) water softeners, b) well water, c) and long periods of no water movement.</p> <p>Other factors that may contribute to smelly water:</p> <ul style="list-style-type: none"><li>• Chlorides of Magnesium and Calcium leave a bitter taste.</li><li>• Chloride of Sodium produces a salty taste.</li><li>• Sulfates (50 ppm) give a medicinal taste.</li><li>• Carbon Dioxide in a low pH water gives fizzy water.</li><li>• Iron and tannic waters also give a bad taste and odor.</li></ul>
<b>TREATMENT</b>	<p>The simplest treatment available is the shock-chlorination of the system. This is a surface treatment, and often requires repeated trials in heavily infected systems. The chlorination of a system requires that you follow each step explicitly to avoid an un-treated portion of the piping system from reinfesting another part. See Bulletin 23 for the chlorination procedure. Longer lasting solutions include chlorination or aeration of the water supply.</p>
<b>NOTE</b>	<p>Since smelly water is caused by a bacteria presence and is not caused by the water heater, any treatment would not be considered warranty related.</p>



# RESIDENTIAL GAS AND ELECTRIC WATER HEATER SERVICE HANDBOOK



## TECHNICAL BULLETIN

A DIVISION OF A. O. SMITH CORPORATION



BULLETIN 23

### CHLORINATION PROCEDURE

<b>CAUSE</b>	The chlorination procedure is used to eliminate various bacteria that accumulate and grow in water heaters. These bacteria often cause odorous or discolored water conditions.
--------------	--

<b>PROCEDURE</b>	Please read the steps of the chlorination procedure prior to beginning. If you feel uncomfortable performing any of these steps, contact a service person to perform this procedure for you.
<i>STEP 1</i>	Turn off the gas or electric supply to the tank.
<i>STEP 2</i>	Turn off the cold water supply valve to the tank.
<i>STEP 3</i>	Open a nearby hot water faucet to relieve the vacuum.
<i>STEP 4</i>	Drain all the water from the tank (a water-hose may be needed).
<i>STEP 5</i>	Remove the anode rod(s), and close the drain valve.
<i>STEP 6</i>	Using a funnel in the anode opening add one gallon of household chlorine bleach (e.g. Clorox or Purex) for every 25 gallons of tank capacity.
<i>STEP 7</i>	Reinstall anode rod(s) after inspecting and replacing as needed.
<i>STEP 8</i>	Open cold water supply valve and refill the system. Then draw the water to <u>every</u> hot water fixture, until the smell of chlorine is detected. Operate dish and clothes washers until a noticeable amount of the chlorine is detected as well. <b>All hot water lines must receive treatment.</b>
<i>STEP 9</i>	Leave the chlorine solution undisturbed for one hour or more.
<i>STEP 10</i>	After the contact time has elapsed, drain the tank according to steps #2, #3, & #4.
<i>STEP 11</i>	Close the drain valve and refill the tank. Allow the tank to sit for 15 minutes. Repeat steps #2, #3, and #4. Continue to flush the tank if the water is discolored or contains a chlorine odor.
<i>STEP 12</i>	Close the drain valve and refill the tank. Flush <u>all</u> chlorine from the piping by opening every hot water outlet/ appliance.
<i>STEP 13</i>	Return hot water heating system to service by following the recommended start-up procedure posted on the unit or in the manual.

# RESIDENTIAL GAS AND ELECTRIC WATER HEATER SERVICE HANDBOOK



## TECHNICAL BULLETIN

A DIVISION OF A. O. SMITH CORPORATION



BULLETIN 35

### NOT ENOUGH HOT WATER - GAS

<b>CAUSE</b>	Not enough hot water complaints are becoming more frequent in the water heater industry. This increase was triggered when changes required by our regulatory agencies were implemented. For example, heaters are now factory preset at a lower temperature and inlet tubes have been shortened. While lower temperatures settings reduce the burn rate, and shorter dip tubes guard against stacking, both affect the amount of hot water a water heater can supply. The following test will help determine if a water heater is supplying the intended amount of hot water and will help pinpoint any problems that exist.
--------------	---

<b>TEST</b>	Please read all the steps of the test prior to beginning. If you feel uncomfortable performing any of these steps, contact a service person to conduct this test for you.												
<i>STEP 1</i>	At the faucet nearest to the water heater, time (in seconds) how long it takes to fill a 1 gallon bucket (flow rate).  $\text{Gallon per minute (gpm)} = 60 \text{ seconds} / \text{seconds to fill a 1 gallon bucket}$ <i>If the bucket fills in:</i> <ul style="list-style-type: none"> <li>10 sec = 6 gpm</li> <li>12 sec = 5 gpm</li> <li>15 sec = 4 gpm</li> <li>20 sec = 3 gpm</li> <li>24 sec = 2.5 gpm</li> </ul>												
<i>STEP 2</i>	Turn thermostat dial on the water heater so the arrow points to "A" position.												
<i>STEP 3</i>	Run about 15 gallons of hot water from the nearest faucet. Shut water off.												
<i>STEP 4</i>	Water heater should complete heating 15 gallons in approximately 20-35 minutes.												
<i>STEP 5</i>	At a nearby faucet using a candy thermometer, measure the hot water temperature.												
<i>STEP 6</i>	The temperature should fall between 120°F to 140°F.												
<i>STEP 7</i>	Continue running the hot water until 60% of the tank capacity is depleted: <table style="margin-left: auto; margin-right: auto; border: none;"> <thead> <tr> <th style="text-align: left;"><b>CAPACITY</b></th> <th style="text-align: left;"><b>DEplete</b></th> </tr> </thead> <tbody> <tr> <td>30 gallons</td> <td>18 gallons</td> </tr> <tr> <td>40 gallons</td> <td>24 gallons</td> </tr> <tr> <td>50 gallons</td> <td>30 gallons</td> </tr> <tr> <td>75 gallons</td> <td>45 gallons</td> </tr> <tr> <td>100 gallons</td> <td>60 gallons</td> </tr> </tbody> </table>	<b>CAPACITY</b>	<b>DEplete</b>	30 gallons	18 gallons	40 gallons	24 gallons	50 gallons	30 gallons	75 gallons	45 gallons	100 gallons	60 gallons
<b>CAPACITY</b>	<b>DEplete</b>												
30 gallons	18 gallons												
40 gallons	24 gallons												
50 gallons	30 gallons												
75 gallons	45 gallons												
100 gallons	60 gallons												
<i>STEP 8</i>	At the same faucet using a candy thermometer, measure the water temperature.												
<i>STEP 9</i>	The temperature should be about 30°F below the temperature in step 6.												

<b>THE FIX</b>	Step 6 - if the temperature was not within range, check the thermostat. Step 9 - if more than 30 °F was lost, check the dip tube.
----------------	--

# RESIDENTIAL GAS AND ELECTRIC WATER HEATER SERVICE HANDBOOK



A DIVISION OF A. O. SMITH CORPORATION



## TECHNICAL BULLETIN

BULLETIN 36

### NOT ENOUGH HOT WATER - ELECTRIC

<b>CAUSE</b>	Not enough hot water complaints are becoming more frequent in the water heater industry. This increase was triggered when changes required by our regulatory agencies were implemented. For example, heaters are now factory preset at a lower temperature and inlet tubes have been shortened. While lower temperatures settings reduce the burn rate, and shorter dip tubes guard against stacking, both affect the amount of hot water a water heater can supply. The following test will help determine if a water heater is supplying the intended amount of hot water and will help pinpoint any problems that exist.
--------------	---

<b>TEST</b>	Please read all the steps of the test prior to beginning. If you feel uncomfortable performing any of these steps, contact a service person to conduct this test for you.														
<i>STEP 1</i>	At the faucet nearest to the water heater, time (in seconds) how long it takes to fill a 1 gallon bucket (flow rate).  <div style="text-align: center;"> <p>Gallon per minute (gpm) = 60 seconds / seconds to fill a 1 gallon bucket</p> <p><i>If the bucket fills in:</i> 10 sec = 6 gpm</p> <p style="padding-left: 40px;">12 sec = 5 gpm</p> <p style="padding-left: 40px;">15 sec = 4 gpm</p> <p style="padding-left: 40px;">20 sec = 3 gpm</p> <p style="padding-left: 40px;">24 sec = 2.5 gpm</p> </div>														
<i>STEP 2</i>	Turn both upper and lower thermostat dials on the water heater to 130° F.														
<i>STEP 3</i>	Run about 15 gallons of hot water from the nearest faucet. Shut water off.														
<i>STEP 4</i>	Water heater should complete heating 15 gallons in approximately 45 minutes														
<i>STEP 5</i>	At a nearby faucet using a candy thermometer, measure the hot water temperature.														
<i>STEP 6</i>	The temperature should fall between 120°F to 140°F.														
<i>STEP 7</i>	Continue running the hot water until 60% of the tank capacity is depleted:  <table style="margin-left: auto; margin-right: auto; border: none;"> <thead> <tr> <th style="text-align: left;"><b>CAPACITY</b></th> <th style="text-align: left;"><b>DEplete</b></th> </tr> </thead> <tbody> <tr><td style="padding-left: 40px;">30 gallons</td><td style="padding-left: 40px;">18 gallons</td></tr> <tr><td style="padding-left: 40px;">40 gallons</td><td style="padding-left: 40px;">24 gallons</td></tr> <tr><td style="padding-left: 40px;">50 gallons</td><td style="padding-left: 40px;">30 gallons</td></tr> <tr><td style="padding-left: 40px;">66 gallons</td><td style="padding-left: 40px;">39 gallons</td></tr> <tr><td style="padding-left: 40px;">80 gallons</td><td style="padding-left: 40px;">48 gallons</td></tr> <tr><td style="padding-left: 40px;">120 gallons</td><td style="padding-left: 40px;">72 gallons</td></tr> </tbody> </table>	<b>CAPACITY</b>	<b>DEplete</b>	30 gallons	18 gallons	40 gallons	24 gallons	50 gallons	30 gallons	66 gallons	39 gallons	80 gallons	48 gallons	120 gallons	72 gallons
<b>CAPACITY</b>	<b>DEplete</b>														
30 gallons	18 gallons														
40 gallons	24 gallons														
50 gallons	30 gallons														
66 gallons	39 gallons														
80 gallons	48 gallons														
120 gallons	72 gallons														
<i>STEP 8</i>	At the same faucet using a candy thermometer, measure the water temperature.														
<i>STEP 9</i>	The temperature should be about 30°F below the temperature in step 6.														

<b>THE FIX</b>	Step 6 - if the temperature was not within range, check the thermostats. Step 9 - if more than 30 °F was lost, check the lower element for continuity and the dip tube.
----------------	--

# RESIDENTIAL GAS AND ELECTRIC WATER HEATER SERVICE HANDBOOK



A DIVISION OF A. O. SMITH CORPORATION



## TECHNICAL BULLETIN

BULLETIN 45

### THERMAL EXPANSION

<b>SYMPTOMS</b>	<ul style="list-style-type: none"><li>• Effects are only noticeable after hot water use followed by periods of no water use.</li><li>• Relief valve drips during any recovery cycle when no hot or cold water is used.</li><li>• Hot water pipes creak while heater is recovering and all valves are closed.</li><li>• Tanks or other components of the water supply system fail prematurely.</li><li>• A metallic creaking noise might actually be heard in the location of the heater as the pressure is relieved and the stretched tank returns to a natural shape.</li><li>• Faucets drips during any recovery cycle when no hot or cold water is used.</li></ul> <p>Water surges when a valve is first open and then pressure drops.</p>
<b>CAUSE</b>	<p>The water in a water heating system expands when it is heated and has a greater volume. Since water will not compress (like air), system designers must include provisions for thermal expansion. (Water in a closed tank at 50 psi, when heated just 10 degrees, will reach a pressure of 250 psi).</p> <p>Many water supply systems have check valves at the water meter to prevent any possible contamination of the public water supply by the accidental back-flow of contaminated water into the supply mains. These check valves are often required by code, and some cities are even installing the check valves. They serve a useful purpose. Do not remove them!</p> <p>The use of pressure reducing valves (PRV) is another cause. PRVs are designed to conserve water and prolong fixture life. Many PRVs also act as very effective check valves. Again, do not remove them!</p> <p>Water softeners in the system may also act as back-flow preventers.</p>
<b>TEST</b>	<p>Follow these easy steps to diagnose thermal expansion:</p> <ul style="list-style-type: none"><li>• Turn the heater thermostat all the way down, and install a water pressure gauge with dead hand (AOS part #4798) on the drain valve. Open the drain valve, so the gauge reads system pressure.</li><li>• Open a hot water tap and allow 15% to 20% of the tanks volume to run out. Shut off the drain valve and make sure that no other fixture in the system, hot or cold, is open. Make sure that outside fixtures, if they are on the same system, are turned off too. Any water leaks or use will make the test meaningless.</li><li>• Check the water pressure gauge, and turn the pointer so it lines up with the pressure indicating needle. Turn the thermostat back up to its normal position, so the heater cycles on. Watch the pressure gauge.</li><li>• If the system is closed, the pressure will start to climb steadily and rapidly. A small amount of thermal expansion control may be built into the system because of trapped air pockets or a water hammer arrestor. In that case the pressure will increase slightly, hold steady for a short time and then rapidly increase. The temperature and pressure relief valve (T&amp;P) or PRV should open and release water once the pressure reaches the maximum setting on the valve. The valve will close once the pressure falls below the pressure setting of the valve.</li></ul>

## RESIDENTIAL GAS AND ELECTRIC WATER HEATER SERVICE HANDBOOK

### THE FIX

The ideal fix involves the use of a pressure reducing valve if supply pressures are above 60 to 70 psi, and a properly sized expansion tank. The PRV reduces supply pressures to 40 to 60 psi allowing an economically priced and sized expansion tank to be used. The PRV also offers the benefit of saving water and prolonging the life of water flow valves. The PRV is not required if the system already has one or if high supply pressures are desired.

The PRV is installed between the check valve and the water heating system. The expansion tank is installed between the PRV and the water heating system. Follow the manufacturers instructions for installing the expansion tank.

Run the thermal expansion check again. The pressure should increase only slightly then hold steady throughout the recovery cycle. The expanded water is flowing back from the heater and into the pressurized storage bladder of the expansion tank. Air pressure will force this water out of the expansion tank into the supply once usage resumes.

**DO NOT DEPEND ON THE T&P VALVE TO HANDLE THERMAL EXPANSION!** The T&P valve, according to the makers of those valves, was designed as an emergency relief device only. The T&P could be subject to reduced effectiveness or failure.

### FIGURE

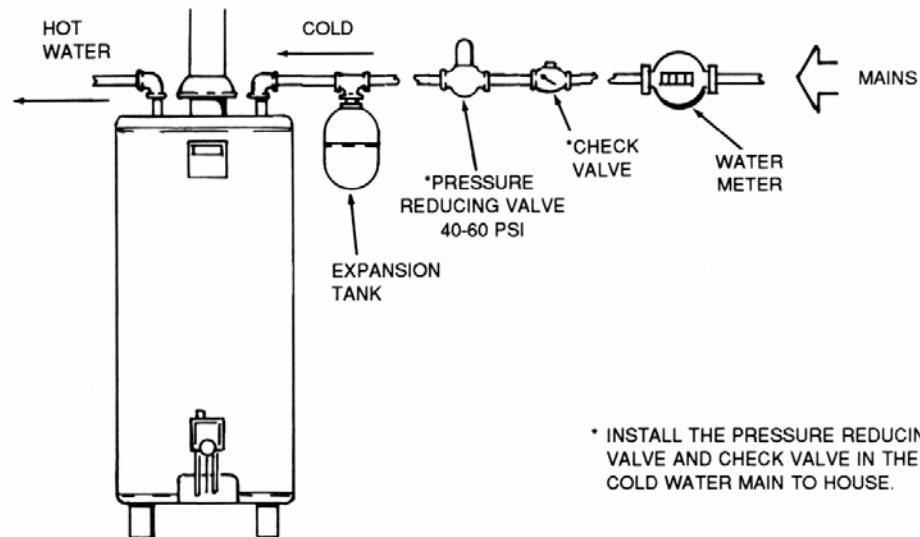

### WARNING

Thermal expansion of water, if not compensated for in system design, will lead to the early failure of components. These failures are not covered by the manufacturer's warranty, so it is extremely important that everyone be aware of the causes, symptoms and solutions to thermal expansion in a closed water heating system.

# RESIDENTIAL GAS AND ELECTRIC WATER HEATER SERVICE HANDBOOK

## TECHNICAL BULLETIN



BULLETIN 52

A DIVISION OF A. O. SMITH CORPORATION



### LEAKING TEMPERATURE AND PRESSURE RELIEF VALVE

<b>SYMPTOMS</b>	<ul style="list-style-type: none"> <li>Water seeping around the relief valve tank connection</li> <li>Leakage at the threaded portion of the relief valve connection</li> <li>Intermittent weeping and/or dribbling from the relief valve</li> <li>Large volume of hot water sporadically discharged from the relief valve</li> </ul>
<b>GENERAL</b>	<p>The temperature and pressure relief valve (T &amp; P) is a safety device limiting temperature and pressure levels in a water heater. Each T &amp; P has both a temperature and pressure rating.</p> <p>Normally, the temperature and pressure relief valve will have a temperature rating for 210°F. A probe (part of the relief valve) extends into the tank measuring the stored water temperature. This probe must be within the top six inches of the water heater. However, if the water heater's thermostat malfunctions, higher than normal water temperatures could be produced. Once the probe senses a temperature exceeding its temperature rating, the relief valve will open to full capacity releasing "very hot" water until the temperature is below its reset temperature.</p> <p>The pressure rating on the relief valve should be the same or less than the certified working pressure of the tank (generally 150 psi) and be below the lowest pressure rating of any system components. It is not acceptable to install a relief valve that exceeds the maximum working pressure of the water heater. Once the pressure in the tank reaches the valve's pressure rating, it will slightly open relieving the pressure. Relieving of pressure can be noted as "dribbling" or "weeping" water from the relief valve.</p> <p>If an incorrectly sized temperature and pressure relief valve is installed, the warranty will be void.</p>
<b>THE FIX</b>	<ul style="list-style-type: none"> <li><u>Seeping at the spud of the water heater</u> - Spuds are welded to the tank and are not repairable. The heater should be replaced.</li> <li><u>Leakage at the threaded relief valve connection</u> - Remove relief valve and reseal connection.</li> <li><u>Intermittent weeping and/or dribbling at the relief valve</u> - The relief valve relieves water slowly when actuating on pressure. A closed system can cause pressure to increase in the system. This condition is called thermal expansion. For additional information regarding thermal expansion please see Bulletin 45.</li> <li><u>Large volume of hot water sporadically discharged from the relief valve</u> - The relief valve relieves water quickly when actuating on temperature. The only cause of this problem is a malfunctioning thermostat.</li> </ul>

**RESIDENTIAL GAS AND ELECTRIC WATER HEATER  
SERVICE HANDBOOK**

---

**PLEASE DO NOT RETURN THIS INFORMATION UNTIL YOU HAVE HAD THIS  
SERVICE HANDBOOK AT LEAST 6 MONTHS.**

Please assist us in making this Service Handbook more useful to you by completing and returning this page.

Date Service Handbook Received: \_\_\_month\_\_\_year

Date Returned to the Technical Training Department: \_\_\_month\_\_\_year

From front cover: Service Handbook part number: \_\_\_\_\_.

I have used this handbook \_\_\_\_\_ times to help service these water heaters.

I would rate this handbook as: no benefit, 1, 2, 3, Okay 4, 5, 6 Very beneficial.

Comments: \_\_\_\_\_

This handbook saved me: no,1, 2, 3, some 4, 5, 6, significant, time on these service calls.

Comments: \_\_\_\_\_

I feel that this handbook is: difficult, 1, 2, 3 okay 4, 5, 6, very easy, to understand and use.

Comments: \_\_\_\_\_

I Would or Would NOT recommend this book to other service agents. (circle answer).

Comments: \_\_\_\_\_

Other methods of receiving service information or training that I would like to have available:

\_\_\_ Internet Based Training                      \_\_\_ Service Computer Disc (CDs)  
\_\_\_ Internet correspondence                      \_\_\_ Prefer written literature  
\_\_\_ Other \_\_\_\_\_

Additional comments or suggestions to improve this service handbook:

**Please cut out this page and return your comments to:  
Technical Training Department - FAX 1-615-792-2135**

Visit the “Information Central” link of [www.hotwater.com](http://www.hotwater.com) for a listing of available Service Handbooks.

For additional information contact:

**A. O. Smith Water Heaters**  
**500 Tennessee Waltz Parkway**  
**Ashland City, TN 37015**  
1-800-527-1953  
[www.hotwater.com](http://www.hotwater.com)

**A.O. Smith**  
Water Heaters