



INSTALLATION AND SERVICE MANUAL

EPJ-SERIES INDIRECT WATER HEATERS

FOR MODELS: EPJ-40-SC, EPJ-56-SC, EPJ-79-SC, EPJ-119-SC



WARNING

Read this manual and all information provided with the appliance before installation, operation, or service. Failure to follow the instructions may result in severe personal injury, death or substantial property damage. Installation and service must be performed by a qualified service technician. Please keep this manual for future reference.

Allied Engineering Company

Division of E-Z-Rect Manufacturing Ltd.

Manufacturers of Gas and Electric Boilers, Heat Exchangers, Electric Boosters, Indirect Tanks
94 Riverside Drive, North Vancouver, B.C. V7H 2M6 • Telephone 604-929-1214 • www.alliedboilers.com

Branches: Calgary • Edmonton • Toronto • Denver



Table of Contents

Section	Page
SECTION 1 - DIMENSIONS AND SPECIFICATIONS	3
1.1 SPECIFICATIONS	3
1.2 DIMENSIONS.....	4
1.3 PRESSURE DROP CHART	5
SECTION 2 - PRE-INSTALLATION	6
2.1 RECEIVING.....	6
2.2 INSTALLATION CODES AND REQUIREMENTS.....	6
2.3 LOCATION	6
2.4 OPERATING RESTRICTIONS.....	7
2.5 WATER QUALITY	7
SECTION 3 – WATER PIPING	8
3.1 BOILER WATER PIPING	8
3.2 DOMESTIC WATER PIPING.....	12
3.3 T&P RELIEF VALVE.....	13
3.4 WATER HAMMER.....	13
SECTION 4 – WIRING	14
SECTION 5 - STARTUP AND ADJUSTMENT	19
5.1 PRE-START UP CHECKLIST	19
5.2 STARTUP INSTRUCTIONS.....	19
SECTION 6 - WATER ADJUSTMENT	20
6.1 CONTROL AQUASTAT.....	20
6.2 AQUASTAT TEMPERATURE	20
6.3 TEMPERATURE ADJUSTMENT	21
SECTION 7 - SERVICE AND MAINTENANCE	22
7.1 GENERAL OPERATION	22
7.2 ELECTRONIC ANODE.....	22
7.3 ANNUAL SERVICE	23
7.4 MONTHLY SERVICE	23
SECTION 8 - TROUBLESHOOTING GUIDE	24
SECTION 9 - WARRANTY REGISTRATION	25
SECTION 10 - NOTES	27



Dimensions and Specifications **Section 1**

1.1 SPECIFICATIONS

Model	Storage Capacity (US Gal.)	R value (ft ² h°F/Btu)	Shipping Weight (lbs)
EPJ-40-SC	38.9	9.8	66
EPJ-56-SC	55.3	9.8	96
EPJ-79-SC	78.1	9.6	115
EPJ-119-SC	115.0	9.5	189

Note: SC = Single Coil

PERFORMANCE						
Model	Boiler Water Flow Rate (US GPM)	Pressure Drop Through Coil (ft. w.c)	1 st Hour Delivery @ 135°F (US Gal.)	Continuous Delivery @ 135°F (US GPH)	Boiler Output Required (Btu/h)	Standby Loss (°F/hr)
EPJ-40-SC	8	2.6	194	160	102,000	0.6
EPJ-56-SC	8	3.2	236	189	119,000	0.5
EPJ-79-SC	13	10.7	348	281	179,000	0.5
EPJ-119-SC	15	7.5	492	391	250,000	0.4

* Note: Ratings are based on 180°F boiler supply and 58°F entering cold water

OPERATING RESTRICTIONS	
Maximum Temperature for Tank:	150°F
Maximum Boiler Water Temperature:	210°F
Maximum Working Pressure for Tank:	150 PSIG

MATERIALS OF CONSTRUCTION	
Tank:	AISI 444 Stainless Steel
Coil:	AISI 444 Stainless Steel
Process:	Pickled and Passivated for corrosion protection
Insulation:	EPS Foam Insulation (2 inch thickness)
Jacket:	Polypropylene
Testing:	Each tank is Factory Pressure Tested to 300 PSI



1.2 DIMENSIONS

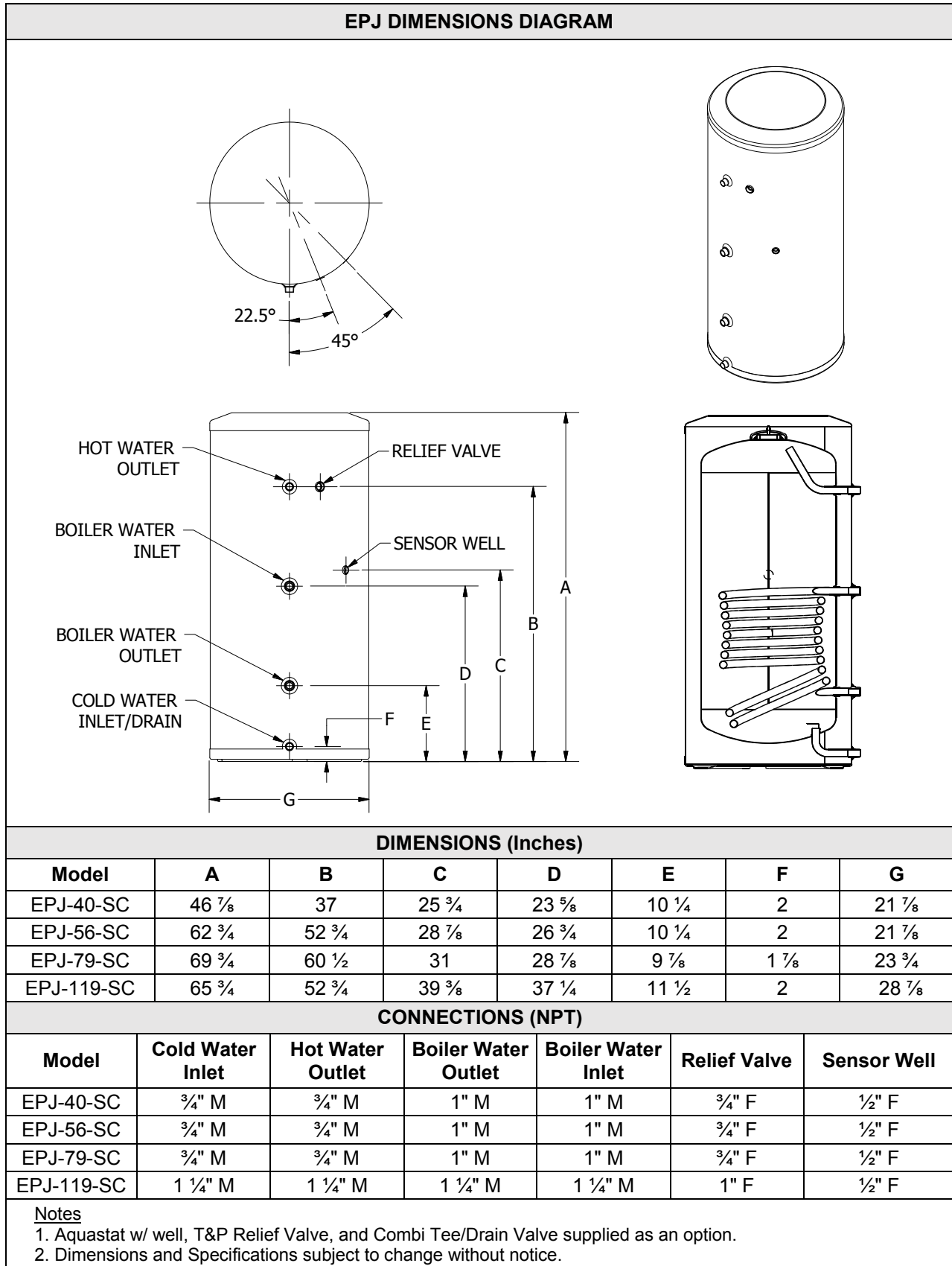



1.3 PRESSURE DROP CHART

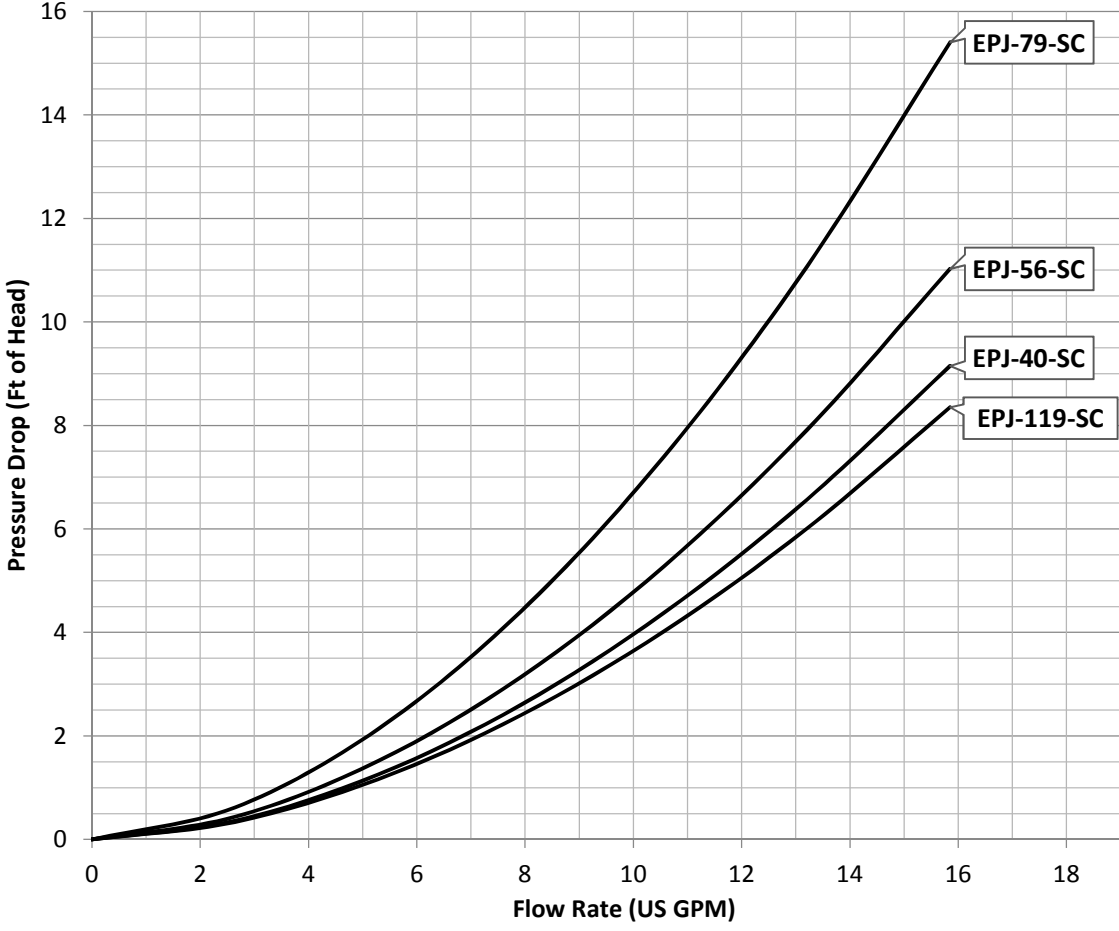

Boiler Water Pressure Drop through Coil



Pre-Installation

Section 2

2.1 RECEIVING

INSPECT SHIPMENT FOR POSSIBLE DAMAGE. All goods are carefully manufactured, inspected, checked and packed by experienced workers. The manufacturer's responsibility ceases upon delivery of goods to the carrier in good condition. Any claims for damage and/or shortage in shipment or non-delivery must be filed immediately against the carrier by the consignee.

Use care when receiving and unpacking the tank. Dropping the tank may cause damage and prevent safe and proper operation.

2.2 INSTALLATION CODES AND REQUIREMENTS

All applicable national, provincial/state, and local codes, laws, regulations, and ordinances must be followed. They expand on and take precedence over any recommendations in this booklet. Authorities having jurisdiction shall be consulted before installations are made.

If an external electrical source is utilized, the indirect water heater must be electrically grounded and installed in accordance with local codes or, in the absence of local codes, with the *National Electrical Code, ANSI/NFPA 70* (current edition) and/or the *Canadian Electrical Code, CSA C22.1 Part 1* (current edition).

If there is any conflict in the above requirements, the more stringent requirement applies.

The installation and service must also conform to the additional requirements in this manual. If there is any conflict with a requirement in this manual and a code requirement, the code requirement must be followed.

2.3 LOCATION

- **DANGER - Risk of Explosion:** Do not use or store gasoline or other flammable fuels or chemicals which have flammable vapors near the tank. The vapors may be ignited by the heat or electronic components of the tank.
- **WARNING:** The indirect water heater should be located in an area where water leakage of the tank or its connections will not result in damage to the area adjacent to the appliance or to lower floors of the structure. When such locations cannot be avoided, a suitable drain pan must be installed under the appliance and the drain pan must be connected to a drain of adequate capacity. Failure to comply with the above could result in severe personal injury, death or substantial property damage.
- **WARNING:** Failure to support and stabilize the water heater could result in severe personal injury, death or substantial property damage. Do not lean items against the water heater. Avoid unnecessary contact with the water heater.
- This tank is designed for vertical installation. Install the tank on an area that is stable, flat, level and capable of supporting the weight of the tank when filled with water.
- This tank should not be placed where freezing might occur and is not to be installed outdoors.
- Although minimal clearance is required for this tank, ensure that there is sufficient room around the tank to access all of the fittings easily. We recommend a **service clearance of 24 inches** around the piping connections.
- This tank must be installed such that any electronic components are protected from water (dripping, spraying, rain, etc.) during appliance operation and service.
- Avoid heat loss and friction loss by locating the tank as close to the boiler as possible. Further heat loss should be avoided by insulating the pipe.
- For the fastest delivery of hot water, locate the water heater in a position central to the points of use.



2.4 OPERATING RESTRICTIONS

WARNING: The heat transfer medium (including additives, if used) must be water or another non-toxic fluid having a toxicity rating of Class 1, as listed in Clinical Toxicology of Commercial Products (current edition). The pressure of the heat transfer medium must be limited to **30 PSIG** by an approved pressure relief valve.

The domestic water in the tank must be limited to a maximum temperature of 150°F and maximum pressure of 150 PSIG by an approved T&P relief valve.

- **Maximum Water Temperature for Tank: 150°F**
- **Maximum Water Temperature for Coil: 210°F**
- **Maximum Working Pressure for Tank: 150 PSIG**

2.5 WATER QUALITY

Always use good quality water to prolong the life of the tank. Water that is safe to drink and even city water is not necessarily good quality water for the tank. The use of water treatment and filters can prevent corrosion and reduce sediment in the tank. Water hardness, pH, and chlorides must be controlled to normal levels.

- **PH levels must be between 6.0 and 8.0**
- **Chlorine, chlorides and aggressive sulfates concentrations must be below 100 parts per million.**

If you are unsure, use a water softening system or consult a qualified water treatment expert.

NOTE: All improper use as detailed above could void the warranty of the indirect water heater.



Water Piping

Section 3

3.1 BOILER WATER PIPING

Connect boiler out (hot) supply piping to the “BOILER WATER IN” fitting on the tank. The “BOILER WATER OUT” fitting on the tank should be piped to the boiler return. Use Teflon tape, pipe dope, or both on all threaded fittings. When installing the pump make sure that the direction arrow is pointing in the same direction as the flow. The use of shut off valves and brass or dielectric unions are recommended when installing your water heater for future service convenience and to prevent galvanic corrosion.

To prevent heat loss due to gravity flow from the coil, a check valve or heat trap with a minimum 12 inch drop should be installed as close to the “boiler water in” fitting as practical. For systems with two or more circulators, a check valve may be used to prevent thermal siphoning from circulator draw.

The heat output of the tank is based on the *temperature* and *flow rate* from the boiler supply. To ensure that the minimum flow rate is provided, the diameter of the pipe between the boiler and tank must be equivalent to or larger than the diameter of Boiler Water connections on the tank (see section 1.2 *Dimensions*). There should be no excessive restrictions due to components (e.g. zone valve, check valve, fittings) or the design of the piping system (e.g. length of run, number of elbows). If a zone valve is used, it should be a minimum of 1” full port and have a flow coefficient of at least $C_v = 8$.

Hot Water Priority

A boiler system connected to multiple zones may be installed so that domestic water heating will be given priority over other zone heating. If hot water priority is used, preventative measures must be taken to ensure hot water priority during cold weather conditions does not result in freezing damage to the other zones.

Zone Circulator System

This system is run the same as a standard heating zone except one zone is piped to the water heater and can be prioritized by using a zone circulator (pump).

Zone Valve System

This system is run the same as a standard heating zone except one zone is piped to the water heater and can be prioritized by using a zone valve.

3-way Zone Valve System

This system overrides the heat demands of all other zones when there is a heat demand from the water heater aquastat and diverts all boiler water to the water heater. There are three ports on a 3-way valve: a common port, a normally closed port, and a normally open port. The common port is connected to the boiler supply side, the normally open port is connected to the heating zones, and the normally closed port is connected to the “boiler water in” fitting of the water heater. The 3-way valve normally allows boiler water to flow through the normally open port to the heating zones. When there is a heat demand from the water heater aquastat, the 3-way valve diverts all boiler water through the normally closed port to the water heater.

Sample Systems

Although there are many possible system designs for your indirect water heater, a few of the most common are described below. Note that all zones can be controlled by using either circulators or zone valves as long as the adequate flow is provided. Always ensure that the circulator is correctly sized to provide the required *Boiler Water Flow Rate* to the water heater.

- Dedicated Single Boiler with Single Tank**
- Radiant Floor / Baseboard with 3 Port Zone Valve – Domestic Priority**
- Radiant Floor / Baseboard with 2 Port Zone Valve – Domestic Priority**
- Radiant Floor / Baseboard Using Circulator and Domestic Hot Water Priority**
- Multiple Water Heaters – Domestic Priority**
- Multiple Water Heaters Piped in Series**



3.2 BOILER WATER PIPING DIAGRAMS

BOILER WATER PIPING

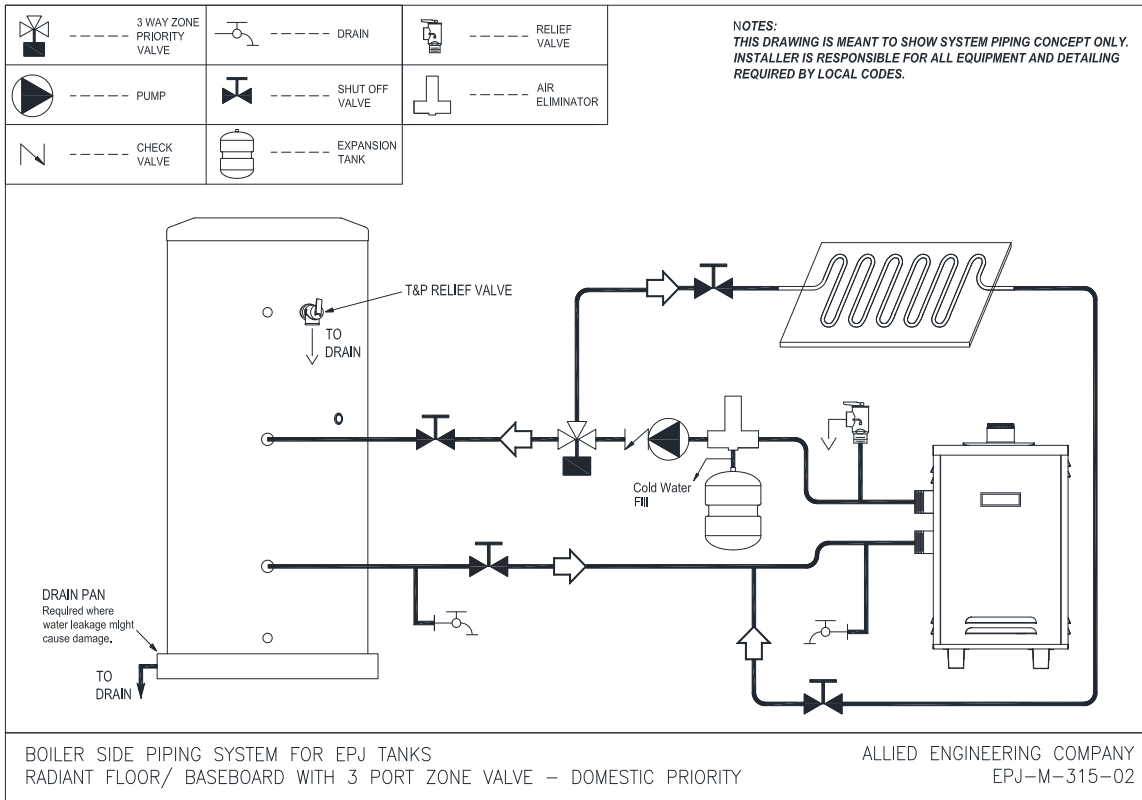
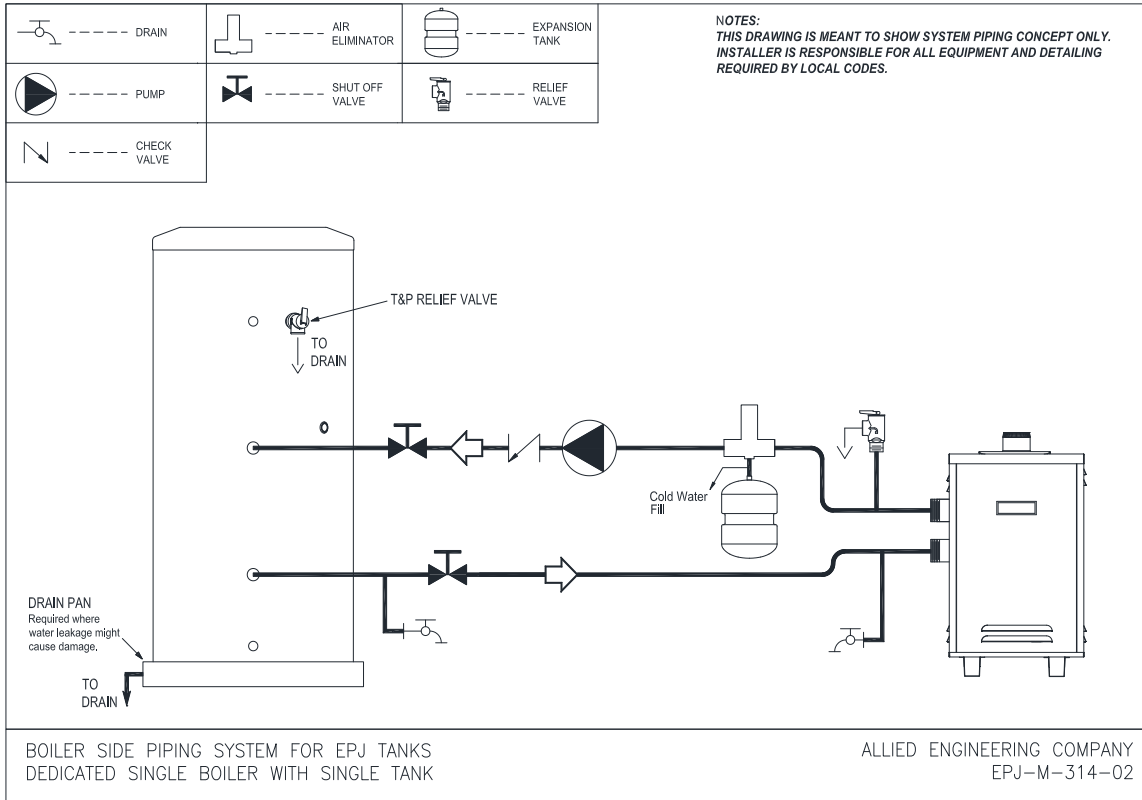



BOILER WATER PIPING

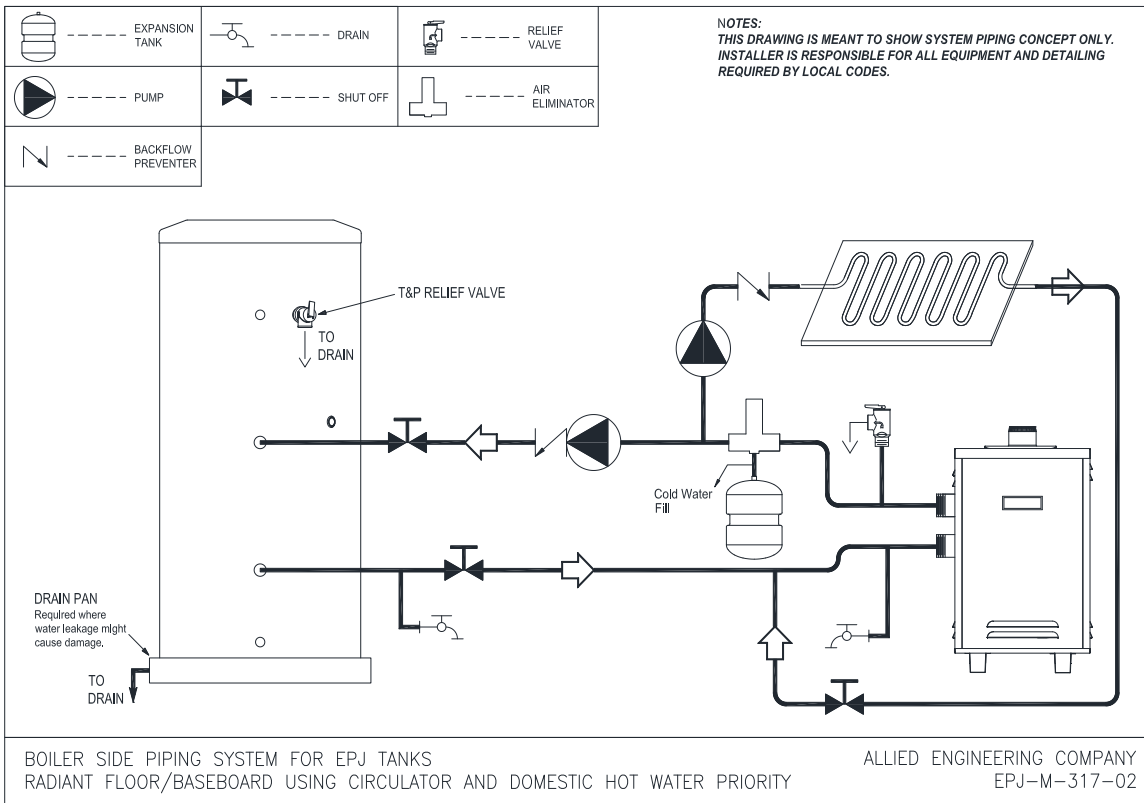
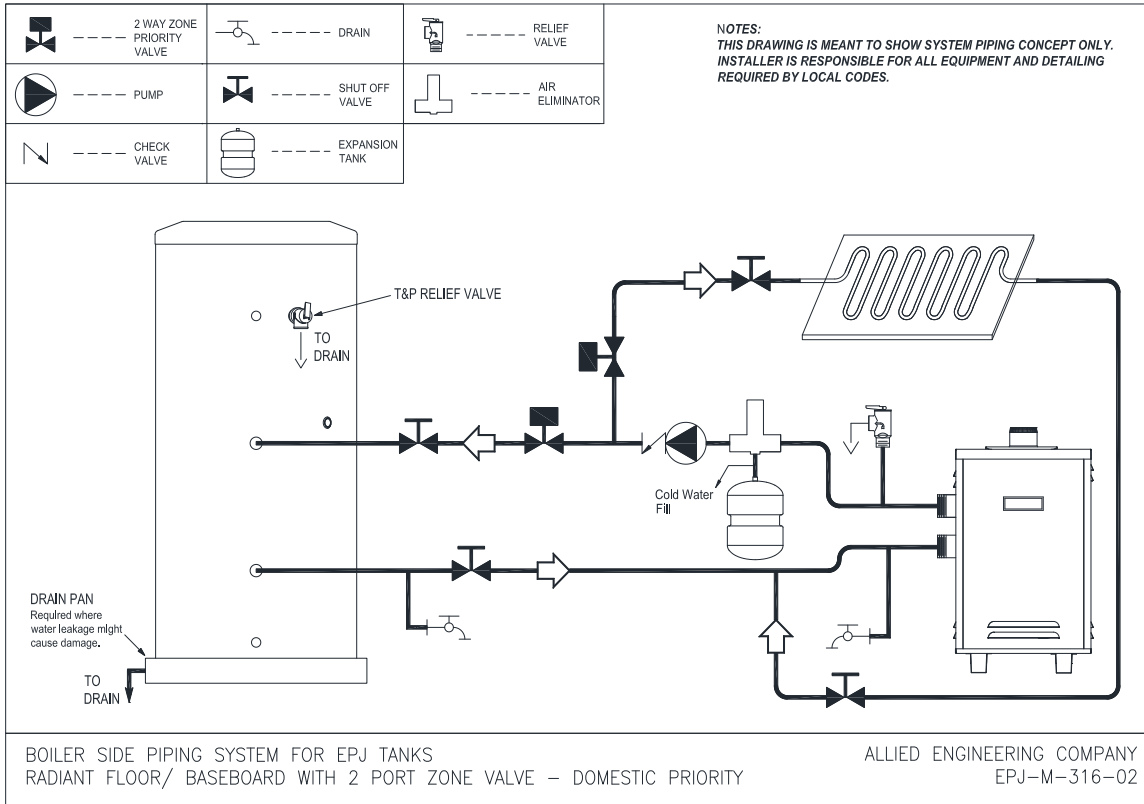



BOILER WATER PIPING WITH MULTIPLE WATER HEATERS

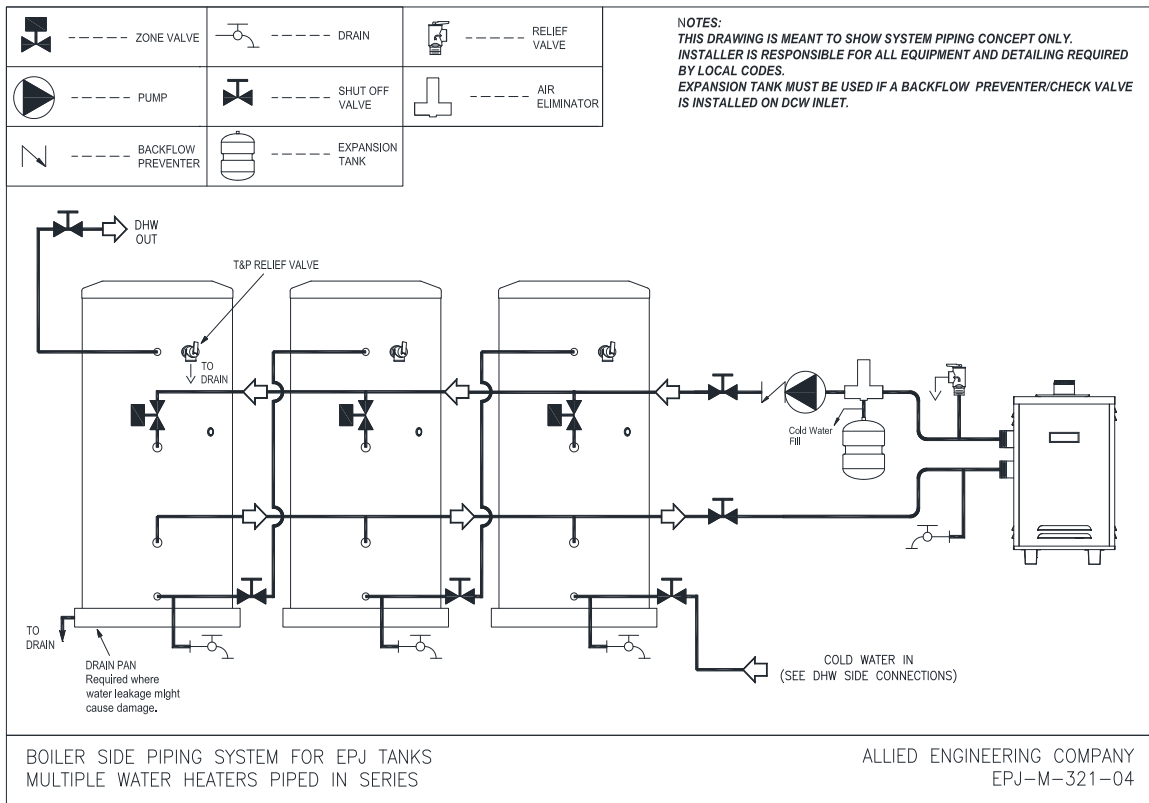
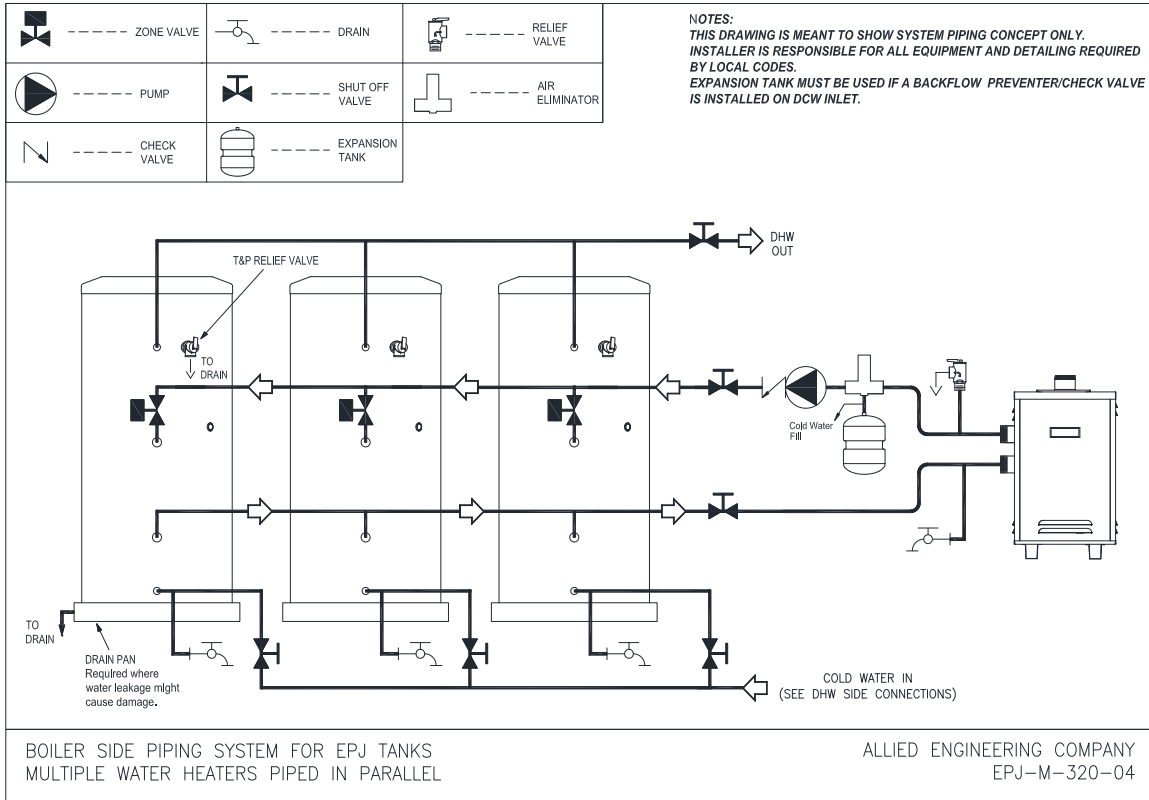



3.3 DOMESTIC WATER PIPING

Connect domestic cold water in to the “DRAIN/COLD WATER IN” fitting and the domestic hot water out to the “HOT WATER OUTLET” fitting. Use Teflon tape, pipe dope, or both on all threaded fittings. Connect a drain valve near the cold water inlet connection so that the tank can be drained. Connect a control aquastat and thermowell to the “SENSOR WELL” fitting. The use of shut off valves and brass or dielectric unions are recommended when installing your water heater for future service convenience and to prevent galvanic corrosion.

If a backflow preventer, check valve or pressure reducing valve is installed upstream of the tank on the cold water inlet, a potable water expansion tank of adequate capacity must be installed in accordance with the manufacturer’s instructions. Do not install any valve or restrictions between the expansion tank and the hot water tank. Improper piping of the expansion tank, check valve or backflow preventer could cause excessive pressure in the tank, tank failure and substantial property damage.

A T&P relief valve must be installed. See section 3.5 *T&P Relief Valve* for important requirements.

A vacuum breaker can protect the tank from collapse. A vacuum breaker must be installed in the cold water supply line with or above the highest point in the tank. No valve is to be placed between the vacuum breaker and the tank. The vacuum breaker manufacturer’s instructions must be followed.

To prevent heat loss due to gravity flow from the tank, a check valve or heat trap with a minimum 12 inch drop should be installed as close to the “hot water outlet” fitting as practical.

3.4 DOMESTIC WATER PIPING DIAGRAM

Domestic Piping with Optional Recirculation and Thermostatic Mixing Valve

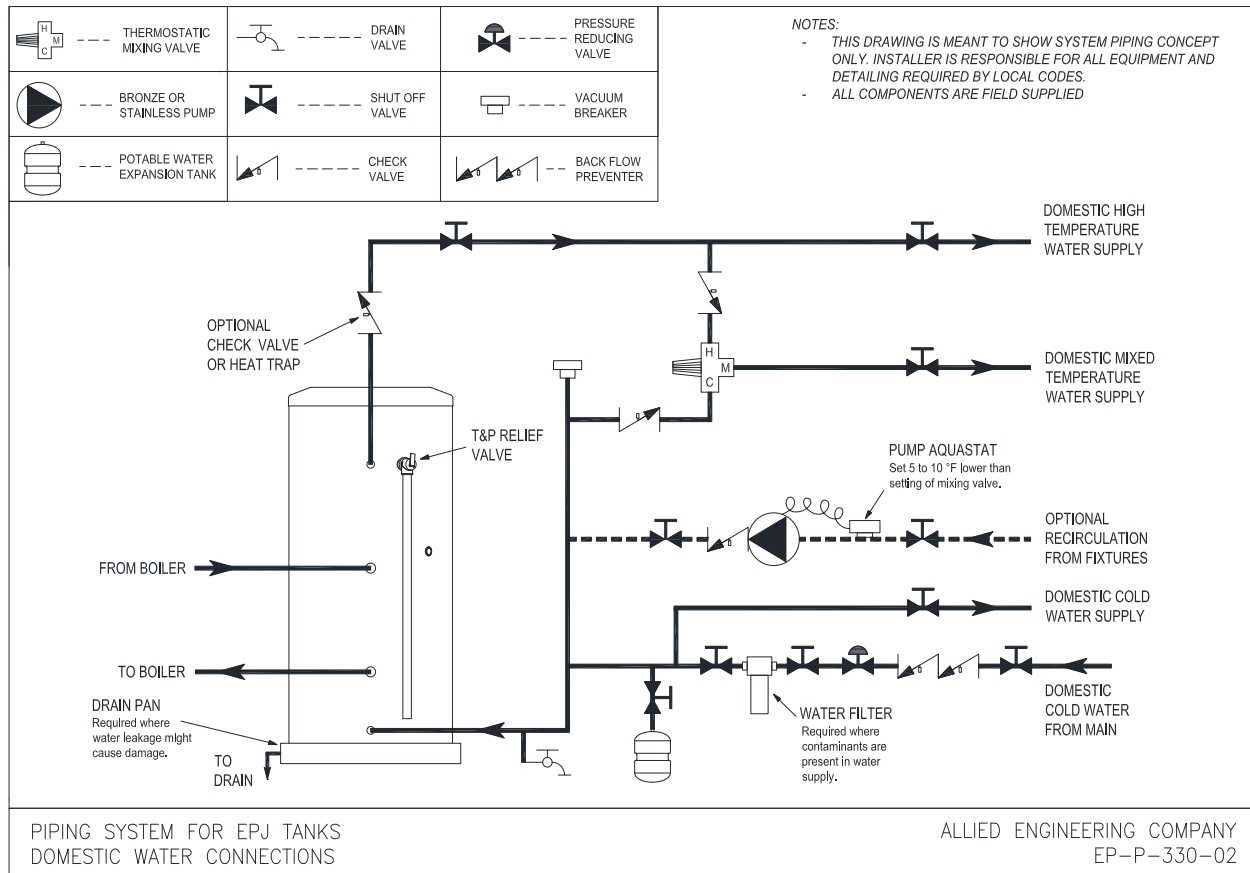



3.5 T&P RELIEF VALVE

DANGER – Risk of Explosion: A T&P (temperature and pressure) relief valve certified by a nationally recognized testing laboratory to the requirements of *ANSI Z21.22/CSA 4.4 - Relief valves for hot water supply systems* must be installed to protect the tank from excessive temperature and pressure. **The T&P relief valve must have a rating greater than the gross input of the boiler connected to the indirect water heater.** The T&P relief valve must have a maximum temperature setting of 150°F and maximum pressure setting of 150 PSIG. Do not plug T&P relief valve or discharge piping. Plugging the T&P relief valve or discharge piping can cause excessive pressure in water heater, resulting in severe personal injury, death or substantial property damage.

WARNING: The T&P relief valve may discharge pressurized hot water and/or steam. Steam exiting the discharge outlet can explosively expand in any direction. Always maintain a safe distance from the discharge pipe outlet in order to avoid potential contact with exiting hot water or steam.

Temperature and pressure settings of a T&P relief valve are factory set and are not adjustable. The service pressure should be at least 25 psi less than the setting stamped on the T&P relief valve.

Install the T&P relief valve directly into the T&P relief valve fitting, labeled “RELIEF VALVE”, so that the temperature sensing element is immersed in water in the top of the tank. No valve, reducing coupling or other restriction is to be placed between the T&P relief valve and the tank connection. No valve, reducing coupling, pipe plug, pipe cap or other restriction is to be placed in the discharge piping. Improper placement or piping of the T&P relief valve can cause severe personal injury, death or substantial property damage.

The discharge line must be installed to allow the complete drainage of both the valve and the line. It shall be independently supported or arranged so as to avoid undue stress on the valve. **Do not pipe in any area where freezing may occur.**

The termination of the T&P relief valve discharge line shall be downward and not directly connected to a sewer line. The outlet of the discharge line shall terminate in the vicinity of a point of drainage within 6” of the floor to eliminate potential risk of scalding, and should terminate freely to atmosphere where any discharge will be clearly visible and is at no risk of freezing.

3.6 WATER HAMMER

Water hammer is a damaging pressure shock wave created when the flow of water is suddenly stopped or reduced (possibly induced by a fast-closing faucet, reducing valve, or solenoid valve in a clothes/dish washing machine). This condition is commonly associated with hammering noises and vibrations; however, lack of noise does not assure that water hammer is not present. Risers or air chambers do not provide protection. To prevent damage to pipes and appliances: (1) install water hammer arrestors of adequate size at all required locations and (2) adequately size pipes to ensure a maximum water velocity less than 5 ft/s.



Wiring **Section 4**

DANGER – RISK OF ELECTROCUTION: Turn off all electric power before attempting any wiring or service. All electrical supply circuits related to the boiler and tank operation must be switched off.

CAUTION: Label all wires prior to disconnection when servicing controls. Wiring errors can cause improper and dangerous operation.

All wiring must be done in accordance with all applicable local codes or, in the absence of local codes, with the National Electrical Code ANSI/NFPA 70 (current edition), and/or the Canadian Electric Code CSA C22.1 Part 1 (current edition). They expand on and take precedence over any recommendations in this manual.

If there is any conflict in the above requirements, the more stringent requirement applies.

The indirect water heater must be grounded in accordance with the above requirements.

Wire the aquastat in accordance with the aquastat manufacturer’s instructions. Wiring for the aquastat is typically connected through the junction box below the aquastat opening. For line voltage connections over 30 volts, wiring must be securely fastened at the junction box opening (field supplied). The aquastat is typically connected in series with the either a zone valve motor or the coil-side of a relay for switching a circulator.

Wiring Diagrams

The following wiring diagrams are meant to show concept only. Installer is responsible for all detailing required by local codes.

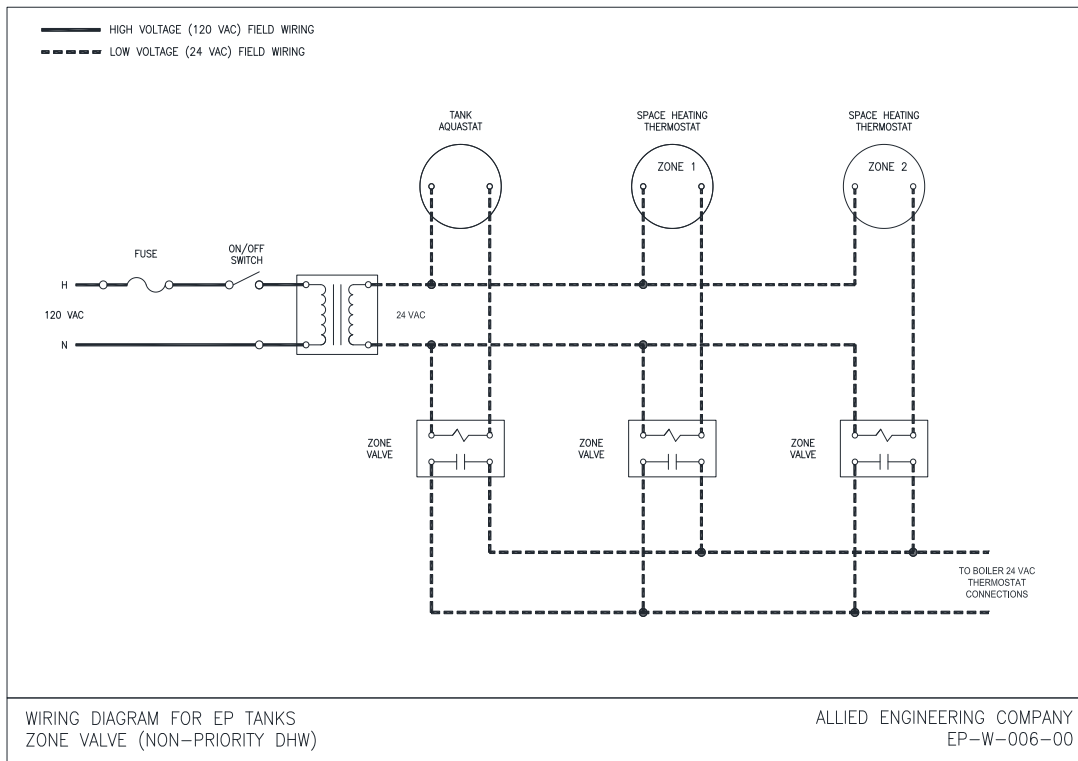

EPJ SERIES INDIRECT WATER HEATERS – Installation and Service Manual

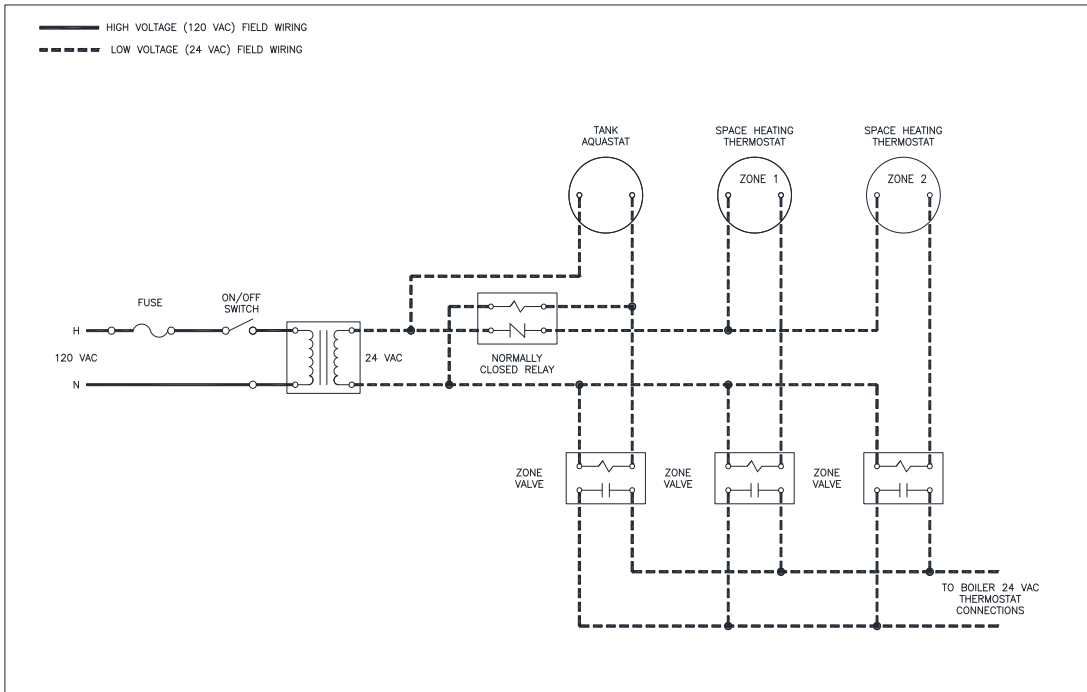

WIRING DIAGRAM FOR EP TANKS
ZONE VALVE (PRIORITY DHW)

ALLIED ENGINEERING COMPANY
EP-W-007-00

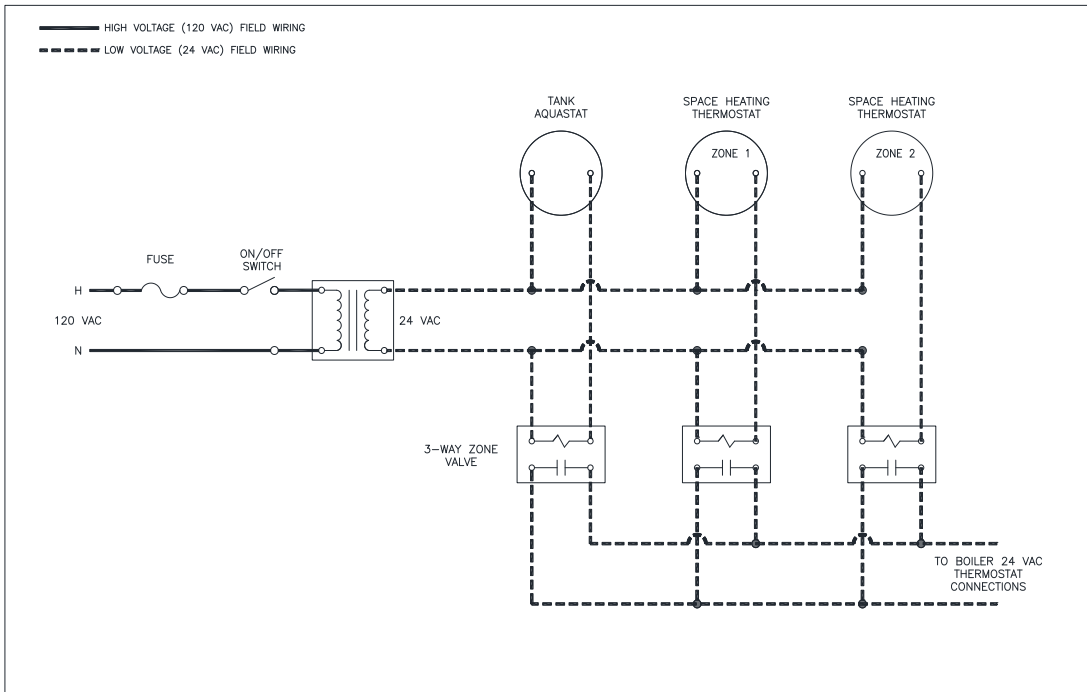

WIRING DIAGRAM FOR EP TANKS
THREE-WAY ZONE VALVE (PRIORITY DHW)

ALLIED ENGINEERING COMPANY
EP-W-008-00

EPJ SERIES INDIRECT WATER HEATERS – Installation and Service Manual

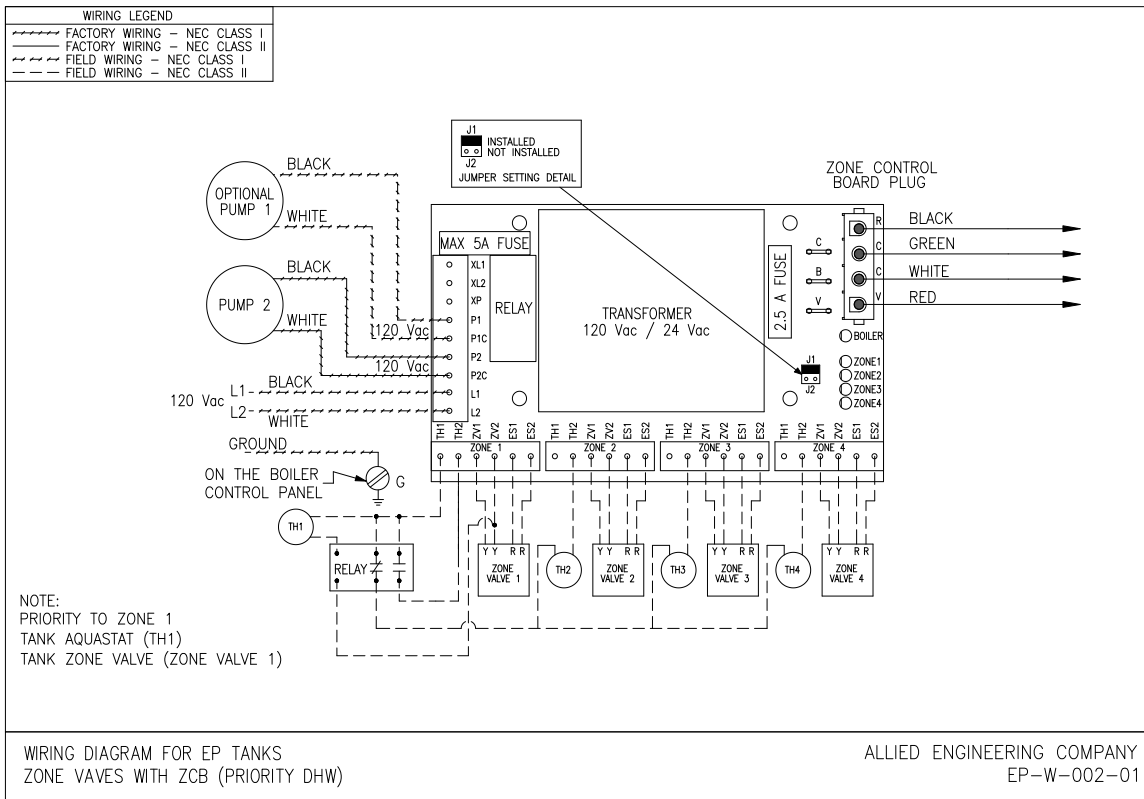
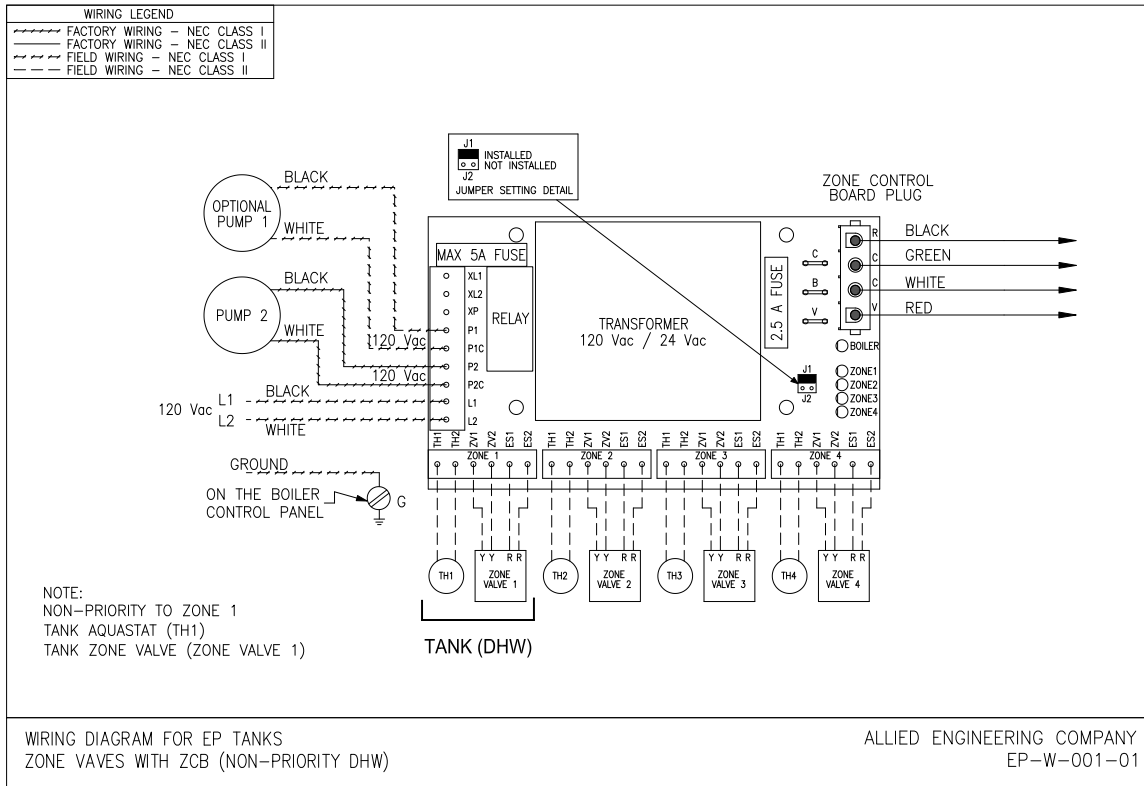

EPJ SERIES INDIRECT WATER HEATERS – Installation and Service Manual

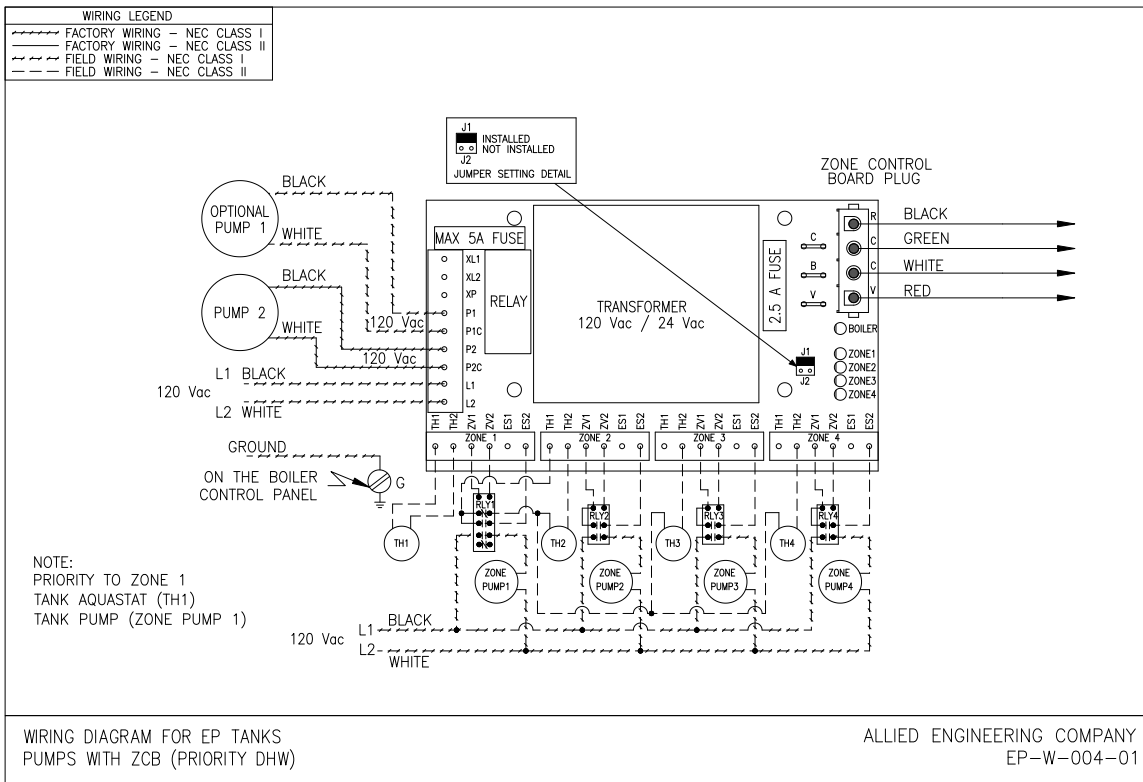
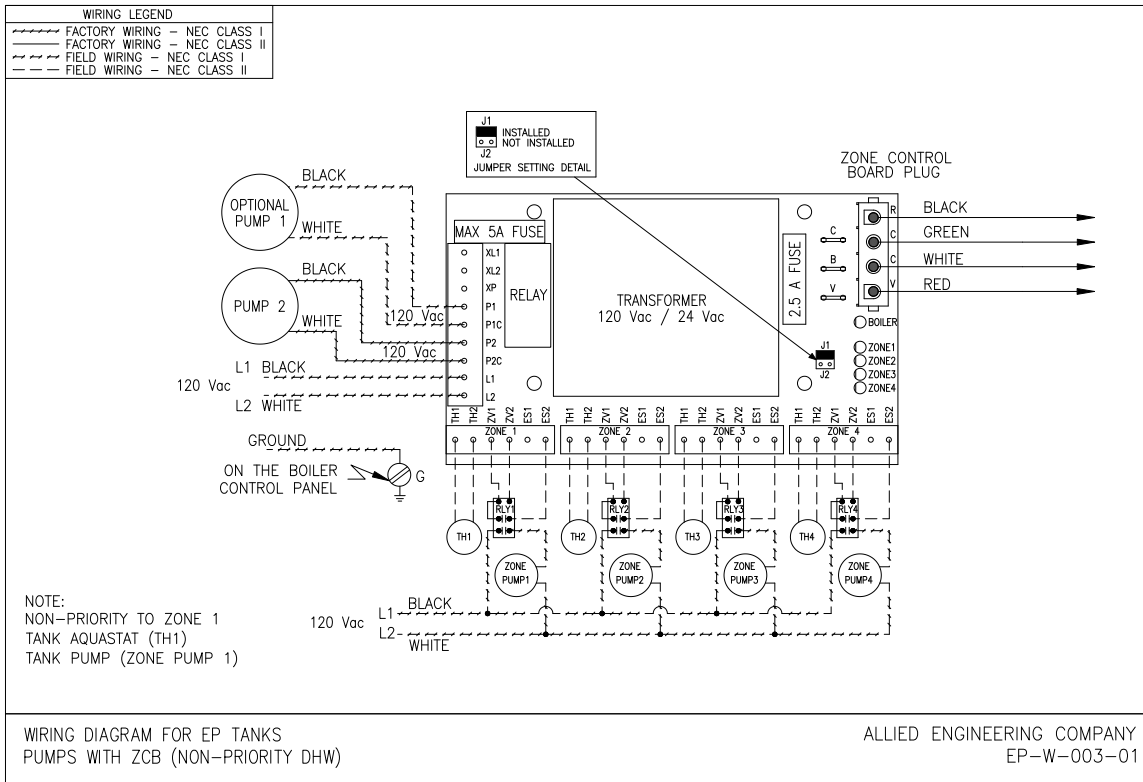

EPJ SERIES INDIRECT WATER HEATERS – Installation and Service Manual

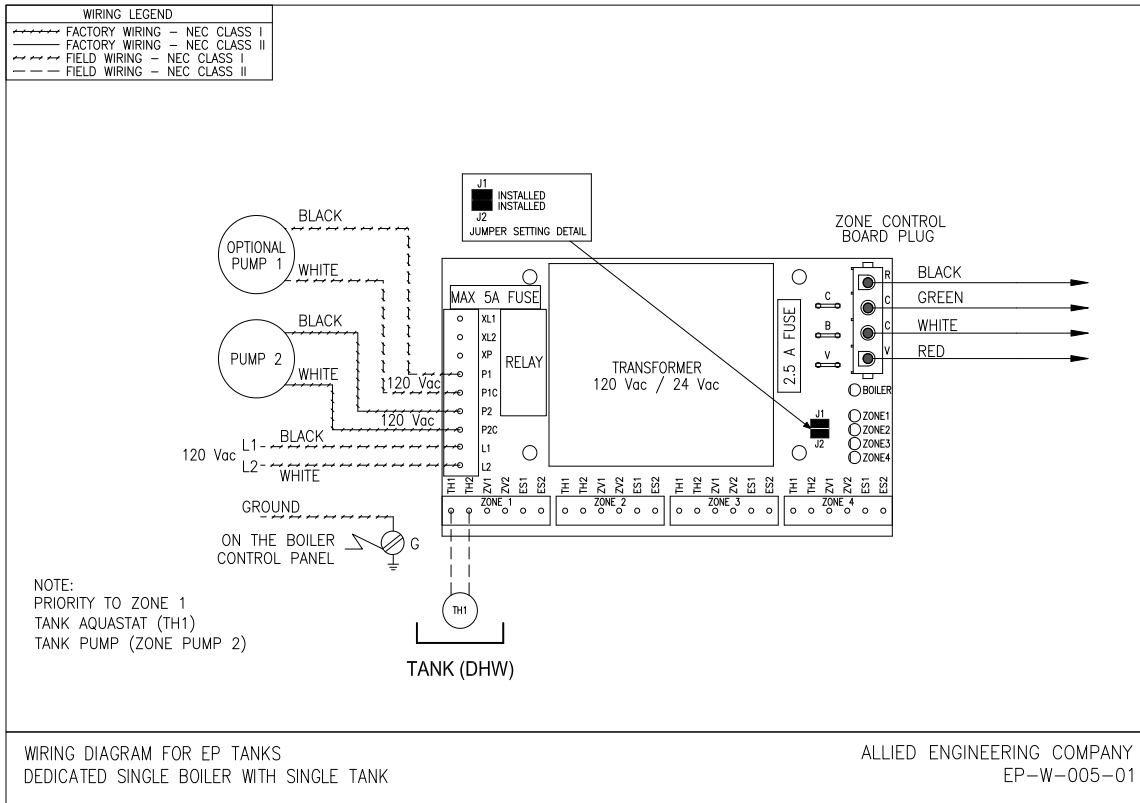



Startup and Adjustment

Section 5

DANGER: Before filling the tank, make sure that the T&P relief valve is installed and that the unit is properly grounded.

CAUTION: Never use tank until it is filled with water and connected to the domestic water piping and boiler piping.

5.1 PRE-START UP CHECKLIST

- T&P relief valve is properly installed and drain discharge is piped to a drain.
- Domestic cold and hot water lines are correctly connected to domestic water system.
- Boiler supply and return piping is correctly connected from boiler to tank.
- Domestic and boiler water systems are set at the correct operating pressure.
- All wiring is installed correctly, no exposed high voltage wiring is present and the unit is properly grounded.

5.2 STARTUP INSTRUCTIONS

1. Make sure all electrical power is OFF.
2. Close the drain valve on tank.
3. Open domestic water supply valve.
4. Open the closest hot water faucet to vent air from the system.
5. Close faucet when there is a constant flow of water.
6. For boiler side piping, follow boiler instructions to purge air.
7. The tank, domestic water piping, and boiler water piping should be completely filled with water and all air purged from both domestic and boiler water systems.
8. Set aquastat on water heater.
9. Power up boiler (following boiler instructions) and water heater.
10. Check boiler is operating normally.
11. Check all zone valves and/or circulators are working properly.
12. Check all connections, fittings and piping for leaks.
13. Adjust the temperature at the faucets as described in the next section.



Water Adjustment **Section 6**

DANGER: Water Temperatures over 125°F (52°C) can cause severe burns instantly or death from scalds. Feel water before bathing and showering. Homes that have small children, elderly and disabled persons may wish to lower the water heater setting to 120°F (49°C) to prevent potential scalding. Below is a table showing the approximate time it takes to have a scalding accident for different temperatures of hot water:

Water Temperature	Length of Time to Cause Scalding
125°F (52°C)	1 1/2 to 2 minutes
130°F (54°C)	about 30 seconds
135°F (57°C)	about 10 seconds
140°F (60°C)	less than 5 seconds
145°F (63°C)	less than 3 seconds
150°F (66°C)	about 1 ½ seconds



Maximum boiler water temperature is 210°F.

A thermostatic mixing valve or tempering valve should be installed on the domestic hot water supply and set to a maximum of 120°F (49°C).

Valves for reducing point of use temperature by mixing cold and hot water are available. Consult a licensed plumber or local plumbing authority.

WARNING: Studies show that dangerous bacteria can form in domestic water distributions systems if a minimum water temperature is not maintained. For example, legionella pneumophila, can form in hot water maintained at 115°F (46°C) or lower. We recommend a domestic water temperature not lower than 122°F (50°C) at faucets and a tank temperature not lower than 140°F (60°C) to limit the potential for legionella pneumophila growth. Contact your local health authority for more information.

6.1 CONTROL AQUASTAT

A control aquastat and thermowell must be installed in order to control the maximum temperature of the tank. The upper limit of the aquastat’s adjustable range must not exceed 150°F.

First, install the well in the “SENSOR WELL” fitting, then insert the control aquastat into the well and secure the set screw on the aquastat body or as per the manufacturer’s instructions. Thermal paste is recommended but not required.

The aquastat will control the tank water temperature within a close tolerance to the aquastat temperature setting, but unusual usage patterns may cause the outlet water temperature to rise significantly above the aquastat setting. To control fluctuating temperature, a thermostatic mixing valve (tempering valve) must be installed.

6.2 AQUASTAT TEMPERATURE

- Use the aquastat to control the maximum water temperature in the tank.
- Household water usage patterns will affect water temperature at any faucet or shower. Always check temperature at every point after adjusting aquastat.
- When hot water is used in repeated small quantities the upper layer of water in tank can be much hotter than lower layers. When adjusting the aquastat, be sure the boiler operating limit control is set a minimum of 20°F (11°C) higher than the aquastat setting. However, in no case should the boiler operating limit control be set above 210°F (99°C).
- Maximum tank temperature is 150°F.



6.3 TEMPERATURE ADJUSTMENT

Allow the water heater to operate several heat-up cycles and check the water temperature at the faucet to verify proper operation.

- If the water at the faucet is hotter than needed:
 1. If a thermostatic mixing valve is used, check that it is properly set.
 2. Adjust the aquastat to a lower temperature setting.
 3. Draw sufficient water or allow the water to sit until another heat-up cycle is initiated.
 4. Wait until the heat-up cycle is completed.
 5. Recheck the water temperature at the faucet.

- If the water at the faucet is colder than needed:
 1. If a thermostatic mixing valve is used, check that it is properly set.
 2. Adjust the aquastat to a higher temperature setting.
 3. If a heat-up cycle begins, wait until the heat-up cycle is completed and recheck the water temperature at the faucet.
 4. If a heat-up does not begin, draw sufficient water or allow the water to sit until a heat-up cycle is initiated. Wait until the heat-up cycle is completed. Recheck the water temperature at the faucet.



Service and Maintenance

Section 7

The *EPJ Series Indirect Water Heater* has been designed to provide years of trouble-free performance in normal installations and requires minimal routine maintenance to ensure a safe and reliable supply of hot water.

7.1 GENERAL OPERATION

- **DANGER:** Before operating the T&P relief valve, make sure no person is near the T&P relief valve discharge piping.
- **DANGER:** Do not plug T&P relief valve or discharge piping. Plugging T&P relief valve or discharge piping can cause excessive pressure in water heater resulting in severe personal injury, death or substantial property damage.
- **WARNING:** This water heater may contain water at very high temperature and pressure. Wear protective clothing, safety glasses and gloves. Ensure the water in the tank and coil has cooled to room temperature before disconnecting fittings, piping or valves or opening the drain valve. Do not solely rely on the pressure and temperature gauges to determine the temperature and pressure of the water in the water heater.
- If the temperature and pressure relief valve on the appliance discharges periodically, this may be due to thermal expansion in a closed water supply system. Contact the water supplier or local plumbing inspector for information on how to correct this situation. Do not plug the temperature and pressure relief valve.
- Hydrogen Sulfide gas can be produced in a hot water system that has not been used for a long period of time (generally two weeks or more). Hydrogen Sulfide gas is extremely flammable. To prevent the possibility of injury under these conditions, we recommend the hot water faucet to be open for several minutes at the kitchen sink before you use any electrical appliance which is connected to the hot water system. If hydrogen is present, there will probably be an unusual sound such as air escaping through the pipe as the hot water begins to flow. There should be no smoking or open flame near the faucet at the time it is opened.
- Verify proper operation after servicing.

7.2 ELECTRONIC ANODE

- Most installations do not require the use of an anode, however, in extremely corrosive water conditions, we recommend the use of an **Electronic Anode** that is non-sacrificial (e.g. "Corro-Protec"). A sacrificial anode, such as magnesium or aluminum, is not recommended and may result in accelerated corrosion.
- The Electronic Anode should be installed in the top of the tank using the factory supplied kit. Please contact the factory for details.
- Follow the anode manufacturer's instructions regarding installation and inspection to ensure continuous and proper operation. The inspection should be performed annually but may need to be more frequent in areas with water having low pH values or high hardness.



7.3 ANNUAL SERVICE

The owner or user should have a qualified heating technician perform annual service as follows:

1. Water Piping: Check all domestic water and boiler water piping for signs of leakage at joints, valves, unions and other fittings.
2. Controls and Valves: Check function of controls and valves as per the control/valve manufacturer's instructions. If the circulator is oil-lubricated, follow the instructions on the circulator to oil it.
3. Flushing the tank:
 - a) When draining tank use caution as water will be hot.
 - b) Shut off power.
 - c) Shut off domestic water supply to tank. To relieve pressure in tank, open a hot water faucet.
 - d) Open drain valve. Allow water to flow until it runs clear or empties.
 - e) For chemical flushing, remove the T&P relief valve and apply the chemical flushing technique as per the manufacturer's instructions. Replace T&P relief valve after treatment.
 - f) Close drain valve.
 - g) Open domestic water inlet shut-off valve. Close hot water faucet after flow is established.
 - h) Resume power.
4. T&P Relief Valve: **DANGER: Before operating T&P relief valve, make sure no person is near the T&P relief valve discharging piping.** Hot discharge water can cause severe personal injury or substantial property damage. Check T&P relief valve is in accordance with manufacturer's instructions. If such instructions are not available, perform the following: move operating lever to open position for a few seconds and then move it back, allowing it to snap closed. If the relief valve continues to release water, close cold water inlet to water heater immediately. Follow "Flushing the tank" instructions to drain water and replace T&P relief valve.

7.4 MONTHLY SERVICE

Visual Check: Visually check joints, valves and other fittings for leaks. Call a qualified service technician to repair any leaks found.

These instructions are for general guidance only. Please contact a qualified heating technician or plumber for requirements of local codes and standard procedures.



Troubleshooting Guide **Section 8**

Problem	Possible Cause	Solution
No Hot Water	Tank control failure	<ul style="list-style-type: none"> • Check wiring and power supply • Replace control
	Aquastat not calling for heat	<ul style="list-style-type: none"> • Check wiring • Replace aquastat
	Air lock in domestic water loop	<ul style="list-style-type: none"> • Purge and bleed piping
	Circulator not operating	<ul style="list-style-type: none"> • Repair or replace circulator
	Zone valve not operating	<ul style="list-style-type: none"> • Check wiring and power supply / open manually to check • Replace zone valve
	Boiler not operating	<ul style="list-style-type: none"> • Boiler control too low • Check wiring • Check disconnect switch • Check fuse or circuit breaker • Check wiring and power supply
Insufficient Hot Water	Temperature setting too low	<ul style="list-style-type: none"> • Adjust aquastat or tempering valve to higher setting
	Defective aquastat or improper calibration	<ul style="list-style-type: none"> • Replace aquastat
	Undersized water heater	<ul style="list-style-type: none"> • Install adequate water heater
	Undersized boiler with no priority to domestic hot water	<ul style="list-style-type: none"> • Rewire for priority / check sizing
Slow Hot Water Recovery	Undersized boiler with no priority to domestic hot water	<ul style="list-style-type: none"> • Rewire for priority / check sizing
	Inadequate boiler water flow	<ul style="list-style-type: none"> • Check circulator sizing • Ensure valve is open • Purge and bleed piping
	Circulator capacity too low	<ul style="list-style-type: none"> • Replace circulator with correct one
	Scale build-up in tank	<ul style="list-style-type: none"> • Chemical cleaning or repeated flushing
Water Too Hot	Aquastat setting too high	<ul style="list-style-type: none"> • Adjust aquastat to lower setting
	Aquastat continuously runs	<ul style="list-style-type: none"> • Check wiring • Replace aquastat
	Improper system piping and/or control	<ul style="list-style-type: none"> • Check piping and flow control valve
	Improper system wiring	<ul style="list-style-type: none"> • Check wiring
	Tempering (mixing) valve	<ul style="list-style-type: none"> • Read valve instructions or consult with manufacturer
Discharge From T&P Relief Valve	Inlet cold water pressure too high	<ul style="list-style-type: none"> • Install pressure reducing valve
	Excessive water pressure when heating	<ul style="list-style-type: none"> • Install properly sized potable thermal expansion tank on cold water inlet
	T&P Relief valve leaking	<ul style="list-style-type: none"> • Replace T&P relief valve



WARRANTY REGISTRATION **Section 9**

IMPORTANT

Registration is required to validate your warranty.

Option 1: Please visit www.alliedboilers.com and go to the "Warranty Registration" section of the website to register your product warranty.

Option 2: Please fill out the required information on the card below, detach, insert in an envelope and mail with appropriate postage to Allied Engineering (address provided on opposite side of card).

Note: The 'Serial No.' and 'Model' can be found on the rating plate. The rating plate is located on the jacket of the tank near the sensor well.



CARD MUST BE RETURNED TO VALIDATE WARRANTY
Cette forme doit être complétée et retournée pour valider votre garantie

Serial No. _____ **Model** _____
No. du Série *Modèle*

Date of Purchase _____
Date de l'Achat

Owner's Name _____
Nom du Propriétaire

Owner's Address _____
Adresse

Installed by _____
Nom de l'Installateur

Dealer's Name _____
Nom du Distributeur

Dealer's Address _____
Adresse du Distributeur

NOTE: This card must be filled out and mailed within 30 days of purchase to validate your warranty.
 NOTE: Cette forme doit être complétée et envoyée en dedans 30 (trente) jours de l'achat pour valider votre garantie.

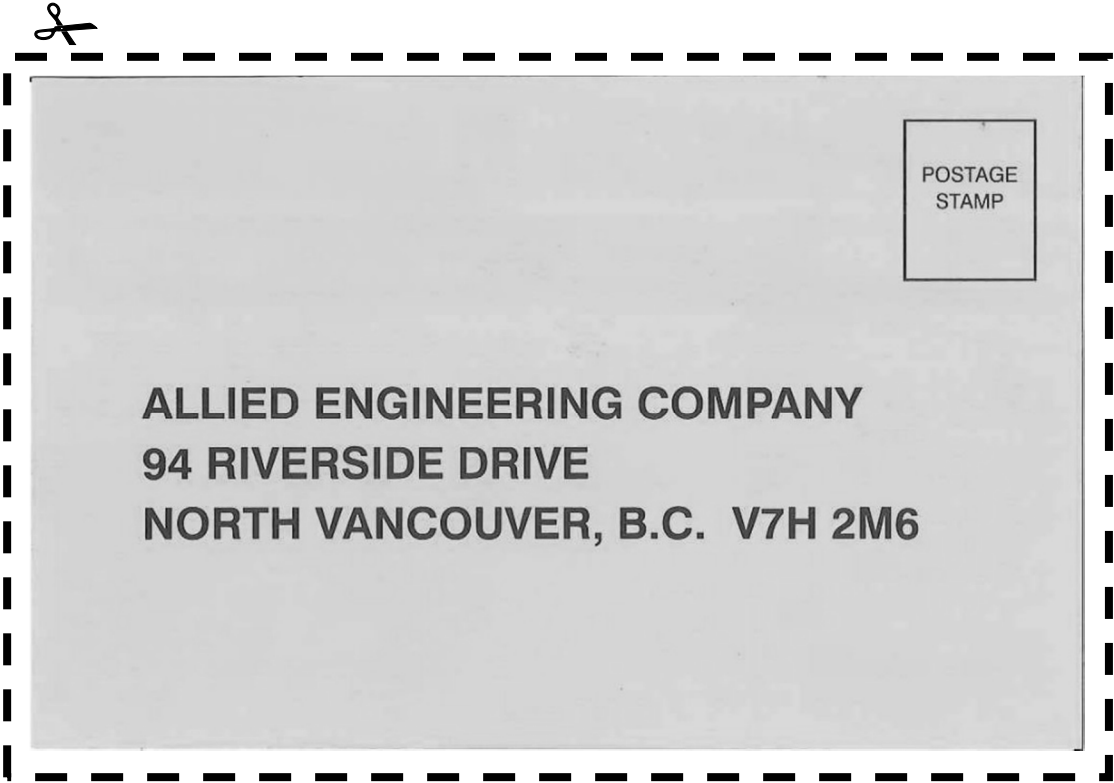



NOTES

Section 10



Manufacturers of Gas and Electric Boilers, Heat Exchangers, Electric Boosters, Indirect Tanks
94 Riverside Drive, North Vancouver, B.C. V7H 2M6 • Telephone 604-929-1214 • www.alliedboilers.com
Branches: Calgary • Edmonton • Toronto • Denver