

# Natural Gas Service

CLICK ANYWHERE ON THIS PAGE  
TO RETURN TO GAS METER CLEARANCES  
INFORMATION at [InspectApedia.com](https://www.InspectApedia.com)

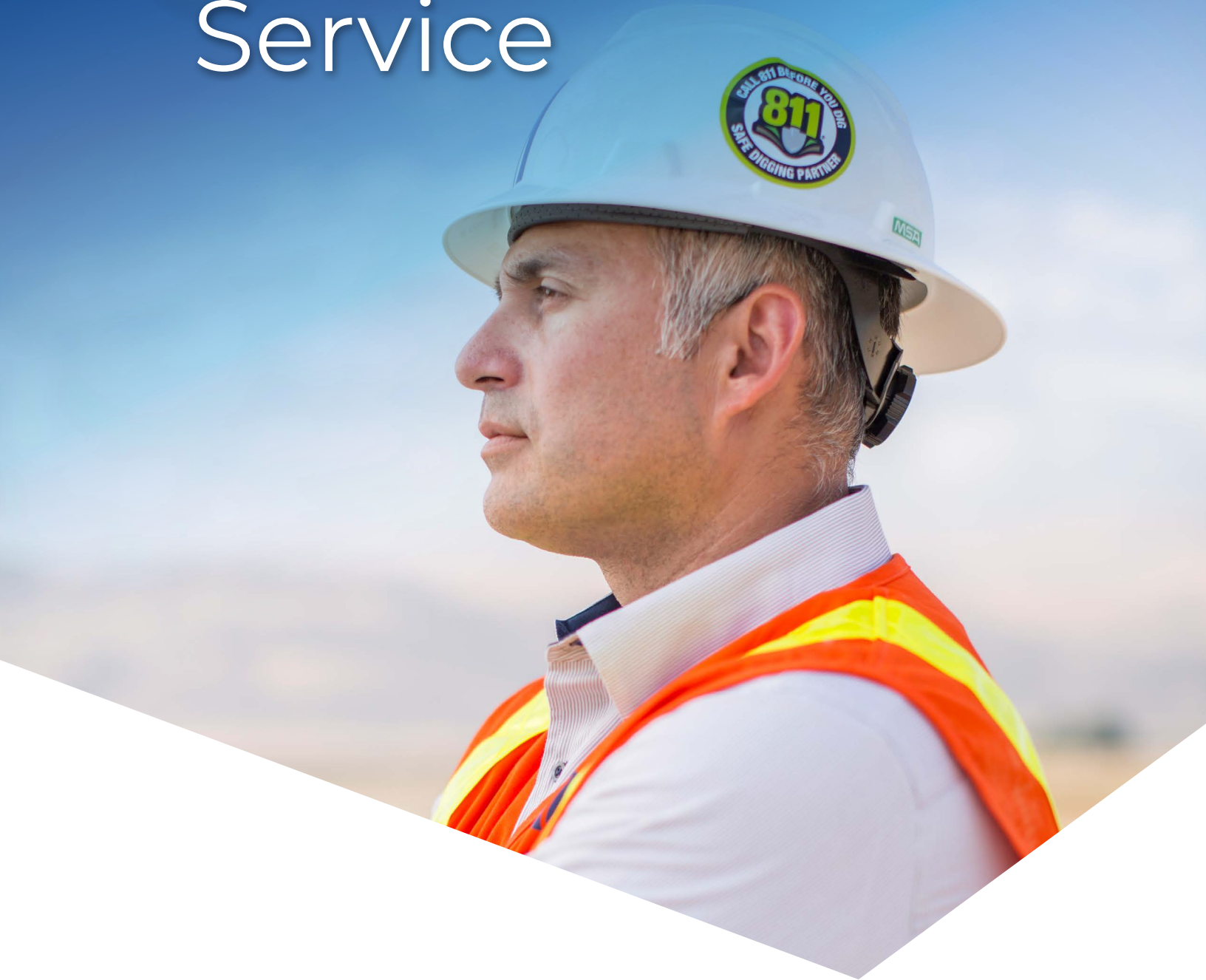

Guidebook  
April 2022



# SOCALGAS®

## NATURAL GAS SERVICE GUIDEBOOK

for  
BUILDERS  
PLUMBING CONTRACTORS  
CITY AND COUNTY BUILDING INSPECTORS  
EMPLOYEES AND CONTRACTORS

April, 2022

The Natural Gas Service Guidebook is a guide to SoCalGas® requirements and policies for establishing natural gas service to new or remodeled applicant installations.

The information contained herein is made available for informational purposes. Although SoCalGas has used reasonable efforts regarding the accuracy of the information at the time of its inclusion, no express or implied representation is made that it is free from error or suitable for any particular purpose. SoCalGas assumes no responsibility for any use thereof by you, and you should discuss decisions related to this subject with your own advisors and experts. In the event of a conflict between this Guidebook and any of CPUC tariffs, decisions and general orders, the tariffs, decisions and general orders shall control.

In addition to SoCalGas' requirements, local and state officials may require additional provisions for the installation of equipment or material in accordance with their authorized areas of responsibility and jurisdiction.

Questions regarding this Guidebook should be emailed to SoCalGas New Business Team ([newbusinessprocessteam@socialgas.com](mailto:newbusinessprocessteam@socialgas.com)) or your SoCalGas representative.

Applicant natural gas service and meter installation arrangements are subject to SoCalGas' review and approval.

NOTE: The trademarked name "SoCalGas" is used throughout this Guidebook to designate Southern California Gas Company.

## SAFETY MESSAGE

Whether you're planning to build a major development or just landscaping your yard, protect your safety and the safety of those around you by calling Underground Service Alert at 811 or by submitting a location request online at [california811.org](http://california811.org) at least two working days (not including the day of notification) prior to excavating. There is no cost to you for this service and it can help prevent injury, costly property damage and loss of utility service. Here is a link for more info: [california811.org](http://california811.org).

## WHAT TO DO

1. **MARK** out your proposed excavation area in white paint or provide other suitable markings. Note that some facility owners will not mark unless the area has been delineated.
2. **CONTACT** Underground Service Alert at 811 from 6 a.m. to 7 p.m., Monday through Friday (excluding holidays) or submit a location request at [california811.org](http://california811.org) at least two working days before digging. NOTE: A working day is a weekday (Monday through Friday) from 7 a.m. to 5 p.m., except for federal and state holidays, as defined in Section 19853 of the California Government Code. Underground Service Alert will contact SoCalGas, as well as other local utilities, to mark the location of all utility-owned lines for free. Notifying Underground Service Alert prior to excavation is required by California law. Failure to comply can carry heavy fines.
3. **WAIT** until we either mark our gas pipelines and indicate pipe material and diameter – or advise the area is clear of our pipes, before digging can begin.
4. **REMEMBER** we only use yellow paint, flags or stakes to mark out the location of our gas pipes. If no natural gas facilities are in your work area you may get a call, email, or see in writing on the ground that indicates “no conflict” or “no natural gas”.
5. **USE** only hand tools within 24" of each marked utility line to carefully expose the exact locations of all lines before using any power equipment in the area. SoCalGas does not mark customer-owned natural gas lines, which typically run from the meter to the customer's natural gas equipment. To have customer-owned lines located and marked before a project, contact a qualified pipe-locating professional. Even if you've hired a contractor, make sure the contractor contacts 811 to have the natural gas lines marked.
6. **REPORT** any pipe damage by calling us immediately at 1-800-427-2200. No damage is too small to report. Even a slight gouge, scrape or dent to a pipeline, its coating, or any component attached to or running alongside the pipe, such as a wire, may cause a dangerous break or leak in the future.  
[Learn more about what to do if you damage or suspect damage to a pipeline or meter.](#)

**NOTE:** Although SoCalGas has been installing Warning Mesh above certain natural gas pipelines to provide notification to those digging, it is not present for all pipelines, therefore please follow the steps above before digging.

## PREFACE

SoCalGas has always striven to provide outstanding customer service and be a positive community influence, as well as deliver a safe, clean and affordable source of energy. Our customers have come to expect our exceptional service, and this Natural Gas Service Guidebook was written with that commitment in mind. The goal is to provide applicants with the knowledge to effectively navigate through SoCalGas' service establishment process including the legal, regulatory, and safety factors that must be considered.

In addition to the SoCalGas requirements and recommendations in this Guidebook, applicants must comply with all applicable California Public Utility Commission (CPUC) decisions and general orders, as well as all SoCalGas' tariffs and rate schedules. Finally, applicants must comply with all federal, state, and local agency regulations and inspection requirements.

In the event of a conflict between this Guidebook and any tariffs, rate schedules, decisions and general orders, the tariffs, rate schedules, decisions and general orders shall control.

**Local and state ordinances require that builders/applicants obtain the appropriate permits and final inspections before SoCalGas can establish natural gas service (meter installation and turn on) to any building, equipment, or structure.**

## TABLE OF CONTENTS

<a href="#">Table of Contents</a>	<a href="#">ii</a>
<a href="#">Table of Figures</a>	<a href="#">iv</a>
<a href="#">Table of Tables</a>	<a href="#">iv</a>
<b><a href="#">SECTION 1 – GENERAL INFORMATION</a></b>	<b><a href="#">1</a></b>
<a href="#">1.1 Service Territory</a>	<a href="#">1</a>
<a href="#">1.1.1. Will Serve</a>	<a href="#">1</a>
<a href="#">1.2 Communications</a>	<a href="#">2</a>
<a href="#">1.2.1. SoCalgas.com Website</a>	<a href="#">2</a>
<a href="#">1.2.2. Email</a>	<a href="#">2</a>
<a href="#">1.3 Permits and Inspections</a>	<a href="#">2</a>
<a href="#">1.4 Design and Installation</a>	<a href="#">2</a>
<a href="#">1.4.1. SoCalGas Responsibilities</a>	<a href="#">2</a>
<a href="#">1.4.2. Applicant Responsibilities</a>	<a href="#">2</a>
<a href="#">1.4.3. Access to SoCalGas Facilities</a>	<a href="#">3</a>
<a href="#">1.4.4. Connecting Services</a>	<a href="#">3</a>
<a href="#">1.5 Advanced Meter Program</a>	<a href="#">3</a>
<b><a href="#">SECTION 2 - LINE EXTENSION PROCESS</a></b>	<b><a href="#">3</a></b>
<a href="#">2.1 Scope</a>	<a href="#">3</a>
<a href="#">2.2 Underground Service Alert (USA) Dial “811”</a>	<a href="#">3</a>
<a href="#">2.2.1 What to Do</a>	<a href="#">3</a>
<a href="#">2.3 Requesting a Natural Gas Service Line Extension – Six–Step Process</a>	<a href="#">4</a>
<a href="#">2.3.1. Step 1 - Submit Application</a>	<a href="#">4</a>
<a href="#">2.3.2. Step 2 - Planning</a>	<a href="#">5</a>
<a href="#">2.3.3. Step 3 - Contract</a>	<a href="#">5</a>
<a href="#">2.3.4. Step 4 – Construction</a>	<a href="#">5</a>
<a href="#">2.3.5. Step 5 - Meter Installation</a>	<a href="#">6</a>
<a href="#">2.3.6. Step 6 – Contract Compliance and Reconciliation</a>	<a href="#">6</a>
<a href="#">2.4 Important Timelines for Natural Gas Service Line Extension Projects</a>	<a href="#">7</a>
<a href="#">2.5 Relocation / Alteration of Existing Natural Gas Facilities</a>	<a href="#">8</a>
<a href="#">2.6 Service Design and Installation Options</a>	<a href="#">8</a>
<a href="#">2.6.1. Applicant Design</a>	<a href="#">8</a>
<a href="#">2.6.2. Applicant Install</a>	<a href="#">9</a>
<b><a href="#">SECTION 3 - NATURAL GAS SERVICE</a></b>	<b><a href="#">9</a></b>
<a href="#">3.1 General Requirements</a>	<a href="#">9</a>
<a href="#">3.2 Service Location</a>	<a href="#">10</a>
<a href="#">3.3 Number of Services</a>	<a href="#">11</a>
<a href="#">3.4 Excess Flow Valves</a>	<a href="#">14</a>
<a href="#">3.5 Trenching</a>	<a href="#">14</a>
<a href="#">3.6 Branch Services</a>	<a href="#">17</a>

<b>SECTION 4 - NATURAL GAS METER SET ASSEMBLIES (MSA)</b>	<b>17</b>
4.1 MSA Features	17
4.2 Number of Meters	17
4.2.1. Individual Meters versus Master Meter - Vented Appliances	17
4.2.2. Resale of Natural Gas (Sub-Metering)	18
4.3 Pressure	18
4.3.1. Standard Delivery Pressure	18
4.3.2. Elevated Delivery Pressure	18
4.3.3. Single-family Residential Elevated Delivery Pressure	18
4.3.4. Multi-family Residential Elevated Pressure Program (2 psig delivery)	18
4.3.5. Elevated Pressure Houeline Verification - Agency Approval	18
4.4 Meter Location	19
4.4.1. General Requirements	19
4.4.2. Meter Protection	19
4.4.3. Preferred Meter Location	21
4.4.4. Discouraged Meter Locations -SoCalGas Approval Required	21
4.4.5. Prohibited Meter Locations	22
4.5 Single-family Residential Meter Configurations	22
4.6 Residential Multiple Meter Manifolds	23
4.7 Non-residential Single Meter Configurations	25
4.8 Non-residential Multiple Meter Manifolds	25
4.9 Marking Houelines for Multiple Meter Locations	25
4.10 Meter Cabinets, Recesses, and Enclosures	25
4.11 Meter Room Requirements	28
<b>SECTION 5 - APPLICANT-OWNED PIPING (HOUSELINE)</b>	<b>31</b>
5.1 Service Delivery Point	31
<b>SECTION 6 - ADVANCED METER LOCATION REQUIREMENTS</b>	<b>32</b>
<b>SECTION 7 - LOCATION OF APPLICANT-OWNED VALVES, STEP-DOWN REGULATORS, AND AUTOMATIC SHUT-OFF DEVICES</b>	<b>32</b>
<b>SECTION 8 - GROUNDING NATURAL GAS PIPE</b>	<b>33</b>
<b>SECTION 9 - NATURAL GAS FLOW PROTECTIVE EQUIPMENT</b>	<b>33</b>
<b>APPENDIX A - Checklist for Applicants with a Request for a Natural Gas Service Line Extension or with a Request to Upsize an Existing Non-Residential Meter</b>	<b>34</b>
<b>APPENDIX B - Checklist for Applicants with a Request for a Relocation/Alteration or Abandonment of Existing Natural Gas Facilities, or with a Request to Upsize an Existing Residential Meter</b>	<b>35</b>

## TABLE OF FIGURES

Figure 1	- SoCalGas Service Territory	1
Figure 2	- Timelines for Contract and Start of Construction for New Natural Gas Line Extension	7
Figure 3	- Single Structure, Single Premise	10
Figure 4	- Mini Riser Vault (MRV)	10
Figure 5	- Residential, Two Structures w/Vented Appliances, Single Premise	11
Figure 6	- Residential – Multi-family/Three or more Structures on a Single Premise with No Vented Appliances in Each Dwelling Unit	12
Figure 7	- Residential – Multi-family/Three or more Structures on a Single Premise with Vented Appliances in Each Dwelling Unit	12
Figure 8	- Service - Residential, Multi-family Single Structure, Multiple Legal Property Lines	13
Figure 9	- Multi-family Residential Single Structure, Single Premise	13
Figure 10	- Single Non-residential Enterprise, Single Premise, with Multiple Structures	13
Figure 11	- Multiple Non-residential Enterprises on a Single Premise, Single Structure	14
Figure 12a	- SoCalGas Distribution Main Joint Trench Diagram (Typical Examples)	15
Figure 12b	- SoCalGas Distribution Service Joint Trench Diagram (Public and Private Property Cross Sections)	16
Figure 13	- Branch Service Diagram	17
Figure 14	- Meter Locations – Distance from Roadways	20
Figure 15	- Typical Protection Post Installations	20
Figure 16	- Offset and Spacing of Protection Posts	21
Figure 17	- New Single Residential Natural Gas Meter Set Separation and Clearance Guidance Diagram	22
Figure 18	- Single-family Residential Standard Delivery Natural Gas Meter Set – Top View	23
Figure 19a	- Multi-family One-Tier Natural Gas Meter Manifold	23
Figure 19b	- Multi-family Two-Tier Natural Gas Meter Manifold	24
Figure 19c	- Multi-family Three-Tier Natural Gas Meter Manifold	24
Figure 20	- Natural Gas Meter Cabinet Guidelines	26
Figure 21	- Single Natural Gas Meter Recess Guidelines	27
Figure 22	- Natural Gas Meter Enclosure – Single Meter Surface Mount	27
Figure 23	- Natural Gas Meter Enclosure – Multiple Meters Surface Mount	28
Figure 24	- Conforming RF Signage Sample	31
Figure 25	- Natural Gas Meter Service Delivery Point	31
Figure 26	- Requirements for New Step-Down Manifolds for Non-Residential 2PSIG, 5PSIG and Above Systems	32
Figure 27	- Requirements for New Step-Down Manifolds for Residential 2PSIG and 5PSIG Systems	32

## TABLE OF TABLES

Table 1	- Common Residential Equipment Connected Load Requirements (BTU/Hour)	4
Table 2	- Meter Recess Dimensions and Riser and Housetline Spacing	26

# SECTION 1

## GENERAL INFORMATION

### 1.1 SERVICE TERRITORY

SoCalGas® has been delivering safe, clean, affordable, and reliable natural gas to its customers for over 150 years. It is the nation's largest natural gas distribution utility, providing safe and affordable energy to 21.8 million consumers through 5.9 million meters in more than 500 communities. The company's service territory encompasses approximately 24,000 square miles in diverse terrain throughout Central and Southern California, from Visalia to the Mexican border. SoCalGas currently has two operating regions and more than 45 operating bases throughout its service territory that provide customer service and natural gas operations for its customers. Planning organizations are centralized within the two operating regions with planners in various offices and bases throughout each region. Visit our website for more information about the communities we serve at the following link [SoCalGas Communities Served](#)

#### 1.1.1. WILL SERVE

Visit [socalgas.com Maps & Descriptions](https://www.socalgas.com/Maps-Descriptions) to get a detailed look of the natural gas service areas of Southern California and to determine if SoCalGas provides service at your project location. Additionally, you may request a letter of availability/facility map for your project by submitting an email message to [newbusinessprocessteam@socalgas.com](mailto:newbusinessprocessteam@socalgas.com). Please include your name, mailing address, email address, and detailed project location in the email message. Your email message will be forwarded to the appropriate Will Serve department at SoCalGas for processing.

**FIGURE 1 - SoCalGas Service Territory**

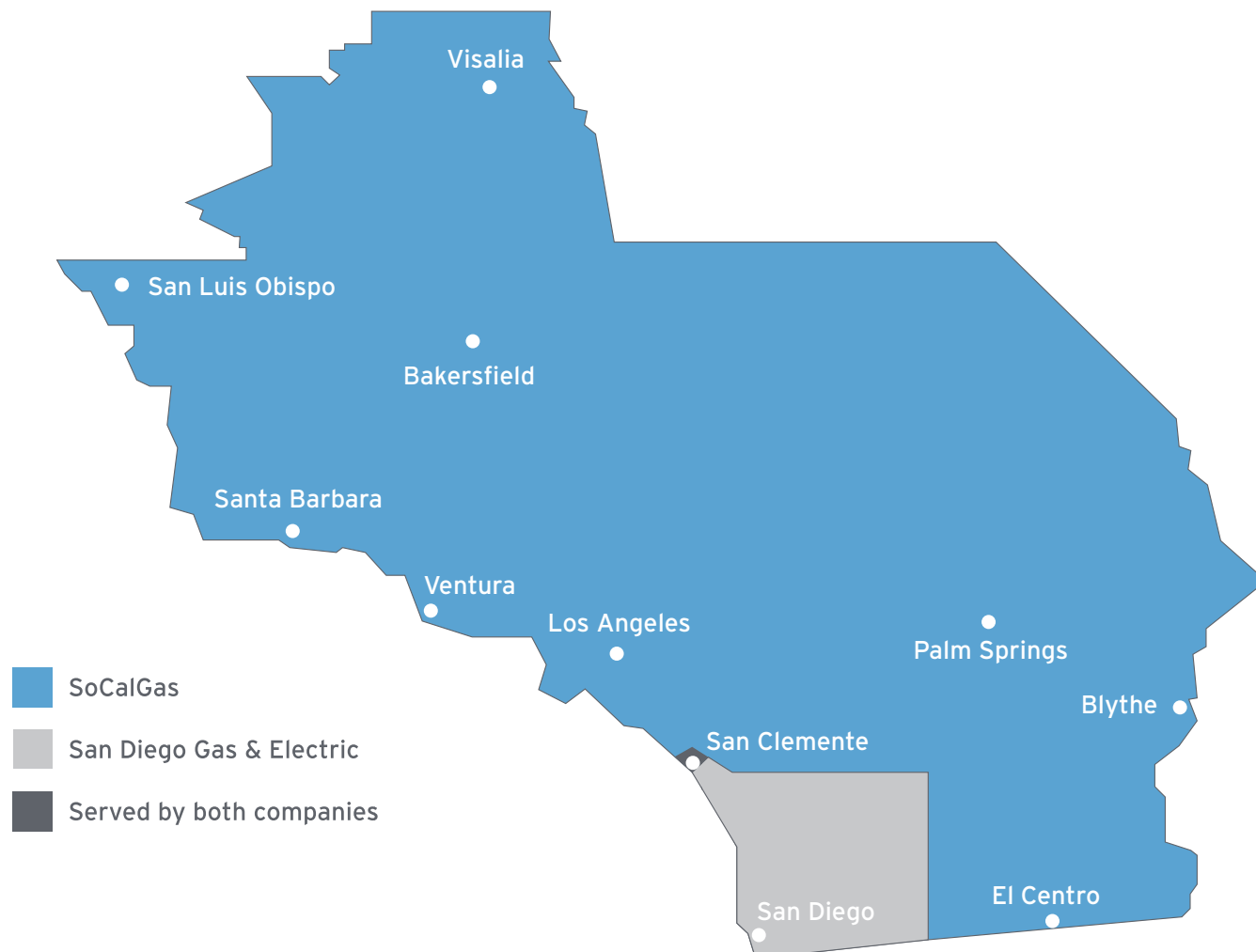



## 1.2 COMMUNICATIONS

To facilitate consistent and efficient service, line extension planning requests are submitted through a centralized process via the [Line Extension Process](#) page on the [socalgas.com](#) website. For those without Internet access, the service process can be initiated via phone by contacting the SoCalGas Customer Contact Center. Your contact information will be forwarded to the appropriate planning office and you will be contacted within 10 working days.

- For residential construction, call: 1-877-238-0092
- For non-residential construction, call: 1-800-427-2000

### 1.2.1. SOCALGAS.COM WEBSITE

SoCalGas' website at [socalgas.com](#) has multiple sections designed to aid customers' interactions with the utility at a single point of entry for billing, requests to start or stop utility service, energy efficiency programs, and other matters essential to providing natural gas service.

#### BUILDER SERVICES

Visit the [socalgas.com Builder Services](#) page to find information on various construction-related topics such as energy efficiency programs, line extension application forms, mapping submittal process, line extension process, contract brochures, etc.

#### ENERGY EFFICIENCY PROGRAMS

Visit the [socalgas.com Energy Efficiency](#) programs page to review a variety of energy-efficiency contracting opportunities to help our customers use energy more efficiently. There are programs ranging from single and multi-family residential to commercial and industrial facility equipment upgrade assistance.

#### RATES AND TARIFFS

Visit the [socalgas.com Tariff](#) page to find a listing of the current SoCalGas tariffs, rate schedules, preliminary statements, rules, forms, advice letters, maps and descriptions, cities and communities served, and other regulatory items.

#### NEW CONSTRUCTION STATUS TRACKER (NCST)

Visit the [socalgas.com NCST](#) page to follow the status of your online application for new natural gas service for both residential and nonresidential projects. It is accessible once you have received your confirmation email message that contains your Project Number and your unique five-digit access code. With the NCST, you will be able to specifically follow the status of the contract for your project, your payment for the project, your project's work order(s), and your project's meter set(s). SoCalGas planning representatives can leverage the NCST to notify you of required documents needed for your project to proceed. You will also receive email notifications when key events take place during your project's lifecycle and

when key changes have been made to the project in the NCST. The goal of the NCST is to enhance communication between SoCalGas and the applicant/builder during the pre-construction and construction stages of a new natural gas service project.

A survey will be sent upon project completion as a means of providing feedback to SoCalGas.

### COST ESTIMATOR TOOL FOR SINGLE-FAMILY NEW CONSTRUCTION & HOME IMPROVEMENTS

SoCalGas offers an online cost estimator tool to single-family homeowners that may provide an approximate cost of installing or modifying a natural gas service pipeline and meter in advance of submitting an application. Visit either [socalgas.com Cost Estimator Tool for Single-family New Construction](#) or [socalgas.com Cost Estimator Tool for Home Improvements](#). A valid street address is required to use these online cost estimators.

### 1.2.2. EMAIL

Please send your questions to the following email address:

Email: [newbusinessprocessteam@socalgas.com](mailto:newbusinessprocessteam@socalgas.com)

Email is the preferred method for submitting questions. It establishes a record for document tracking purposes.

## 1.3 PERMITS AND INSPECTIONS

Adherence to the following guidance is necessary for new and remodeling construction projects:

- Local city and county ordinances
- CPUC rules
- California rules and laws applicable to construction, including building, plumbing, mechanical, and electric codes

Local and state ordinances require that applicants obtain the appropriate permits and final inspections before SoCalGas establishes natural gas service (meter installation and turn-on) to any building or structure.

SoCalGas will not establish natural gas service until the natural gas piping has been installed satisfactorily and has been released by the local inspection agency. In addition, SoCalGas' inspection process may include SoCalGas-established safety based requirements not governed by local or state codes that will need to be satisfied and approved prior to natural gas service activation.

## 1.4 DESIGN AND INSTALLATION

### 1.4.1. SOCALGAS RESPONSIBILITIES

SoCalGas is responsible for planning, designing, and engineering service facilities and extensions using SoCalGas standards for material, design, and construction. All extension facilities installed under line extension procedures shall be owned, operated, and maintained by SoCalGas, except for substructures and enclosures that



are on, under, within or part of a building or structure. SoCalGas is not required to serve via applicant-owned or private lines.

### 1.4.2. APPLICANT RESPONSIBILITIES

Applicants are required to submit "Application for Natural Gas Service" to initiate the line extension process (See Line Extension Process - Section 2.3). Applicants have the right to select either SoCalGas or a third-party SoCalGas-approved contractor to perform the natural gas service design, installation, and trenching. (See Service Design and Installation Options - Section 2.5). Applicants must provide a clear unobstructed route from the nearest permanent and available SoCalGas distribution facility to the point at which natural gas services will be connected and have rights secured by law or under CPUC-approved tariff schedules. These rights include, but are not limited to: installing a locking device to prevent unauthorized access to SoCalGas facilities; providing safe and ready access for SoCalGas personnel, free from unrestrained animals; providing unobstructed access for SoCalGas vehicles/equipment to repair, maintain, and operate SoCalGas facilities; providing unobstructed access for SoCalGas personnel during the removal of SoCalGas facilities after termination of service.

### 1.4.3. ACCESS TO SOCALGAS FACILITIES

SoCalGas requires access to SoCalGas facilities at all times for any purpose connected with the furnishing of natural gas service (meter reading, inspection, testing, routine repairs, replacement, maintenance, emergency work, etc.).

### 1.4.4. CONNECTING SERVICES

Only SoCalGas personnel or agents duly authorized by SoCalGas may connect or disconnect service pipe to or from existing SoCalGas distribution facilities (Main/Service), or tamper, connect, disconnect, remove or perform any work on meters, regulators, tees or any other SoCalGas facility.

An unauthorized connection to SoCalGas natural gas facilities, or to facilities used to provide utility services, may be a violation of the California Penal Code, and subject the person(s) to damages pursuant to *California Civil Code*, or otherwise.

## 1.5 ADVANCED METER PROGRAM

In late 2012, as part of a statewide CPUC effort to upgrade California's energy infrastructure with automated metering technology, SoCalGas initiated the Advanced Meter Program. As part of the program, either a new meter or a communication device (module) will be installed on the existing meter to automatically and securely transmit measurement information via SoCalGas' wireless radio frequency (RF) communication network.

Depending upon site conditions, SoCalGas may need to install additional equipment or require greater spacing on applicant buildings or premises to support the advanced meter communication network. For more information and to follow the Advanced Meter team's progress as it transitions more than 5.9 million SoCalGas natural gas meters, please visit the SoCalGas Advanced Meter web page at the following link: [Advanced Meter](#).

For questions, please send email to:

[AdvancedMeter-NewBusinessTeam@semprautilities.com](mailto:AdvancedMeter-NewBusinessTeam@semprautilities.com).

## SECTION 2 LINE EXTENSION PROCESS

### 2.1 SCOPE

With many SoCalGas® departments involved and many local, state, and federal rules and regulations to follow, the process of establishing a new natural gas line can be confusing and complicated. This section clarifies the general SoCalGas service and meter requirements for residential and non-residential installations.

### 2.2 UNDERGROUND SERVICE ALERT (USA) DIAL "811"



Whether you're planning to build a major development or just landscaping your yard, protect your safety and the safety of those around you by calling Underground Service Alert at 811 or submitting a location request online at [california811.org](http://california811.org) at least two working days (not including the day of notification) prior to excavating. There is no cost to you for this service and it can help prevent injury, costly property damage and loss of utility service. Notifying Underground Service Alert prior to excavation is required by California law. Failure to comply can carry heavy fines.

#### 2.2.1 WHAT TO DO

- 1 **MARK** out your proposed excavation area in white paint or provide other suitable markings. Note that some facility owners will not mark unless the area has been delineated.

- 2. CONTACT** Underground Service Alert at 811 from 6 a.m. to 7 p.m., Monday through Friday (excluding holidays) or submit a location request at [california811.org](http://california811.org) at least two working days before digging. NOTE: A working day is a weekday (Monday through Friday) from 7 a.m. to 5 p.m., except for federal and state holidays, as defined in Section 19853 of the California Government Code. Underground Service Alert will contact SoCalGas, as well as other local utilities, to mark the location of all utility-owned lines for free. Notifying Underground Service Alert prior to excavation is required by California law. Failure to comply can carry heavy fines.
- 3. WAIT** until we either mark our gas pipelines and indicate pipe material and diameter – or advise the area is clear of our pipes, before digging can begin..
- 4. REMEMBER** we only use yellow paint, flags or stakes to mark out the location of our gas pipes. If no natural gas facilities are in your work area you may get a call, email, or see in writing on the ground that indicates "no conflict" or "no natural gas"
- 5. USE** only hand tools within 24" of each marked utility line to carefully expose the exact locations of all lines before using any power equipment in the area. SoCalGas does not mark customer-owned natural gas lines, which typically run from the meter to the customer's natural gas equipment. To have customer-owned lines located and marked before a project, contact a qualified pipe-locating professional. Even if you've hired a contractor, make sure the contractor contacts 811 to have the natural gas lines marked.
- 6. REPORT** any pipe damage by calling us immediately at 1-800-427-2200. No damage is too small to report. Even a slight gouge, scrape or dent to a pipeline, its

coating, or any component attached to or running alongside the pipe, such as a wire, may cause a dangerous break or leak in the future. [Learn more about what to do if you damage or suspect damage to a pipeline or meter.](#)

**NOTE:** Although SoCalGas has been installing Warning Mesh above certain natural gas pipelines to provide notification to those digging, it is not present for all pipelines, therefore please follow the steps above before digging.

## 2.3 REQUESTING A NATURAL GAS SERVICE LINE EXTENSION - SIX-STEP PROCESS

### 2.3.1. STEP 1 - SUBMIT APPLICATION

After you have secured the appropriate permits for construction, submit your application for natural gas with the proposed natural gas facility installation date. The application, a "Request for Service," is required for all new line extension requests and separated based upon customer class - either residential or non-residential. The application should be submitted online and may be accessed from the [Builder Services page](#).

For those without Internet access, the application process can be initiated via phone by contacting the SoCalGas Customer Contact Center:

- For residential construction, call: 1-877-238-0092
- For non-residential construction, call: 1-800-427-2000

To complete the application, it's essential to accurately identify the structure's connected load in BTU units by equipment type or end-use for proper planning. Manufacturer labels should provide the appliances actual connected load. However, Table 1 (below) provides general connected load guidance for common residential equipment.

**TABLE 1 - Common Residential Equipment Connected Load Requirements (BTU/Hour)**

Appliance Type	Natural Gas Usage BTU/Hour
Cooking – Range Top (Stand-alone)	30,000 - 80,000
Cooking – Oven (Stand-alone)	30,000 - 50,000
Cooking – Free-standing Range	60,000 - 130,000
Water Heating – Conventional Tank	30,000 – 100,000
Water Heating – Tankless or On-demand	120,000 – 199,000
Space Heating – Conventional Furnace	80,000 – 120,000
Space Heating – Hydronic Boiler	60,000 – 100,000
Space/Water Heating Combo - Hydronic Unit	80,000 – 150,000
Laundry – Clothes Dryer	30,000 – 50,000
Pool/Spa Heater	250,000 – 500,000
Natural Gas Fireplace	20,000 – 80,000
Natural Gas Grill	20,000 – 60,000
Exterior Natural Gas Lighting	2,000 – 5,000

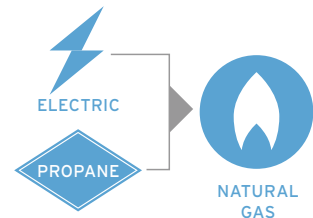

**NOTE:**

If your project is an electric/propane conversion, your application should only list appliances that are convertible to natural gas. If you need your appliances inspected to make this determination, schedule through the SoCalGas Customer Contact Center.

### 2.3.2. STEP 2 - PLANNING

After application submittal is received, a SoCalGas planning representative will contact you within 10 business days to discuss your project needs. In preparation for your initial meeting with the SoCalGas planning representative, please read the [Submitting Your Project Plans Electronically](#) section on [socalgas.com](http://socalgas.com) and the [Natural Gas Service Guidebook](#). These pages on [socalgas.com](http://socalgas.com) will help you determine the information, plans, and documents you will need to provide to the representative. During the initial contact with the planning representative, the representative will review your application, the obligated service requirements and discuss the following site-specific topics prior to commencing your natural gas facility installation plan:

- Trenching and backfill provider
- Meter location
- Natural gas delivery requirements
- Easement/access issues
- Schedule and timing
- Other construction matters (grade/riser, curb/gutter, etc.)

If the requested service exceeds SoCalGas' obligated service per CPUC rules (See Section 1.2.1, Rates and Tariffs), the SoCalGas representative will review service options and potential [Rule 2](#) Section O special facilities ownership charges with you.

### 2.3.3. STEP 3 - CONTRACT

After completing the natural gas facility planning process, a contract with a site-specific installation, fixed-bid cost estimate will be electronically submitted to the email address provided by the Applicant. Your email address is necessary to facilitate the contract process; no solicitation/marketing or any other communication beyond the requested application/contract/verification process will occur. If a valid email address is unavailable, considerable delays in contract delivery and validation may occur.

The estimate includes costs for all appurtenant facilities and fittings, valves, service pipe, service regulators, metering equipment, etc. in excess of estimated allowance. The type of natural gas appliances/equipment you plan to install will help determine the amount of allowance (credit for natural gas usage) applied to your SoCalGas contract. The residential natural gas appliance types qualifying for allowance are: water heating, space heating, both cooktop and oven, clothes dryer stub, and natural gas powered space cooling. Commercial allowances are based on the total estimated annual natural gas usage and verified after 3 years. See [Understanding Your Line Extension Contract](#).

A cost break-down is only provided for the following CPUC-directed applicable categories: main, stub, service, meter, and inspection. SoCalGas does not break down cost based

upon labor, non-labor, equipment, hours, hourly rate, or any other break-down.

If money is due, payment in full must be received in cash or cash equivalent (check, money order, ACH) and recorded by SoCalGas prior to scheduling the construction of the natural gas facility. It may take up to 10 business days to record/post payment to your natural gas facility project. SoCalGas does not accept partial payment and will not install natural gas facilities ahead of payment receipt/recording/posting.

In addition to the cost information, depending upon your request, you will be required to execute several other documents on topics such as the odor conditioning, applicant-provided trench, grade and riser setback, curb and gutter indemnity, storm water agreement, applicant installation bid, elevated pressure, etc.

Execution (signed contract, documents, and payment, if applicable) is required within 90 calendar days of the contract generation date. Failure to comply will result in the re-calculation of costs based upon the then-current system generated costs.

### 2.3.4. STEP 4 - CONSTRUCTION

Once the contract and documents are signed, payment is posted (if required), and all other pre-requisites are satisfied (permitting, environmental, cultural, easements, etc.), your line extension project is ready for scheduling. There is a processing lead time of ten business days for the project to be at the scheduler. If a specific date is requested it must be within 90 calendar days after contract execution since SoCalGas natural gas facility construction must commence within 90 calendar days after contract execution. After that time if the installation of natural gas facilities has not begun for the project, SoCalGas has the right to revise the contract and recalculate the costs to reflect the then-current, system-generated costs of the project. SoCalGas also has the right to not begin construction if job site is deemed unsafe (work area must be free of any scaffolding or obstruction).

SoCalGas has New Business Construction Liaisons who are responsible for handling the construction schedule for all customer-driven work where pipe is required to be installed. They work with Applicants after the project has been scheduled for construction. If you need to contact the Liaisons after your new natural gas line project has been scheduled for construction, send an email message with your name, phone number, and SoCalGas Work Order number to [NewBusinessConstructionLiaison@semprautilities.com](mailto:NewBusinessConstructionLiaison@semprautilities.com). The Liaisons will reply within one business day. Please note that the New Business Construction Liaisons do not handle the schedule for meter sets and turn-ons. The group who handles the meter set and turn-on schedule is outlined in STEP 5 - METER INSTALLATION.

If builder/applicant's scheduling changes from the planned installation that could result in either a reduction or increase in the contracted work, a change order will be created. If the change requires an additional payment, the payment must be made prior to construction or if during construction, within 30 calendar days after generation. Meters will not be set until the change order payment is satisfied. When the change order results in a refund, SoCalGas will provide refund after project is constructed and reconciled.

Applicants can decide if they would like the trench to be provided and backfilled by a contractor of their choice. The contractor must be Operator Qualified and be on an approved Drug & Alcohol plan to perform these two tasks, known as "Covered Tasks," per 49 CFR 192 Subpart N. SoCalGas utilizes [Veriforce](#)<sup>®</sup> to verify the qualification of personnel performing Covered Tasks prior to contract generation and at work scheduling, and a SoCalGas Inspector visits the construction site to verify operator qualifications. If you are looking to get your contractor Operator Qualified or have questions regarding Operator Qualification, the Drug and Alcohol plan, and Common Covered Tasks, please send your inquiry/question, name, and contact information to [ContractorOpQual@socalgas.com](mailto:ContractorOpQual@socalgas.com). Total time is anticipated to be approximately three to four weeks to become an approved vendor (for minimum cover and backfill and to receive Drug & Alcohol plan approval). Having a dedicated person to follow up with all aspects of operator qualification and Drug & Alcohol on a daily basis, until completed, helps to minimize the amount of time it takes to be listed in [Veriforce](#)<sup>®</sup>.

If providing the trench, builders/applicants should be sure to have the trenching ready at a minimum of one business day prior to the scheduled natural gas facility construction date to avoid installation delays or additional costs. Also, it is the builder/applicant's responsibility to provide shading materials and to cover the pipeline once it is installed by Operator Qualified personnel (per 49 CFR 192 Subpart N). Our installing crew cannot leave the site until shading is completed to our satisfaction, so be sure to have personnel and material at the ready on natural gas facility installation day and to ask SoCalGas about the appropriate shading material prior to work scheduling. SoCalGas requires a warning mesh to be installed above its natural gas pipeline to further improve damage-prevention efforts. This mesh will be provided by SoCalGas. When natural gas facility construction is completed, the natural gas line is ready for service and the meter installation can be scheduled.

It is recommended to coordinate with local agency building offices to ensure building code compliance to avoid houseline approval issues. It is also essential to establish a billing account prior to requesting meter set and turn-on to avoid meter installation delays. SoCalGas has two ways to

establish an account - either online ([Start New Service](#)) or by phone:

- Residential 1-877-238-0092
- Non-residential 1-800-427-2000

### 2.3.5. STEP 5 - METER INSTALLATION

Some residential projects are eligible to participate in the SoCalGas Pre-scheduled Meter Set Program. Builders/applicants with eligible projects may submit requests for meter set and turn-on prior to local agency final inspection and houseline okay under the following conditions:

- The final inspection date is set and confirmed with the local agency
- Notification was made to the SoCalGas Meter Set Desk a minimum of three weeks prior to the final inspection date (Note: before notifying the SoCalGas Meter Set Desk, please work with the SoCalGas planning representative to process a Multiple Application Worksheet (MAW) for the meter sets to be included in the Pre-scheduled Meter Set Program)

Meter installations will then be pre-scheduled to occur four days after the anticipated inspection date. SoCalGas must receive the houseline okay at least 48 hours prior to this pre-scheduled install date or it will be rescheduled according to next availability. For more details about the SoCalGas Pre-scheduled Meter Set Program, please visit: [www.socalgas.com/construction](http://www.socalgas.com/construction).

For all other meter set and turn-on requests, notify SoCalGas once the final inspection and houseline okay is complete. Our typical meter installation wait times are between seven to 14 business days after notification. Be aware that during the heating/re-lighting season (typically November through February) meter set and turn-on wait times can be more than 20 business days.

- Meter Set Desk: 800-228-7377 or [setdesk@socalgas.com](mailto:setdesk@socalgas.com)

SoCalGas will not set meters if job site is deemed unsafe (work area must be free of any scaffolding or obstruction).

### 2.3.6. STEP 6 - CONTRACT COMPLIANCE AND RECONCILIATION

If allowance was granted for your line extension contract, meter(s) must be turned on within six (6) months of the SoCalGas construction completion date (ready to serve date) for projects that include main and service; or twelve (12) months for projects that do not involve main (service only). Failure to do so will result in a SoCalGas bill for the amount of allowance granted and any applicable additional funds such as the Income Tax Component of Contributions and Advances (ITCCA).

The ready-to-serve date is not usually the meter set date; rather, it is the date that natural gas service piping is gassed-up and verified at the service valve (stop-cock); or

for main only contracts, the date that the main is tied into the existing system and gassed-up/energized.

Once the meter is turned on, the line extension project is reconciled within the following timelines:

- For residential, no later than one year after the ready to serve date.
- For non-residential, during the 36th month after the ready-to-serve date.

For residential contracts, earned allowance is verified based upon the installed end uses recorded during the meter set and turn on process performed by SoCalGas Customer Service personnel and then compared to the contracted end use. Deviations are investigated and if the actual end use is found to be different than what is contracted, a change order will be issued resulting in a bill with ITCCA. Failure to satisfy the reconciliation bill will result in withholding of upfront allowances for future projects until payment is made in full.

For non-residential contracts, earned allowance is dependent upon actual consumption as measured monthly for 36 months and then compared with the contracted projected consumption. The comparison takes the annualized amount of consumption either on a three-year average basis or the actual third year's consumption - whichever is greater - against the projected consumption.

- If consumption is greater than projected, a refund up to the amount paid plus ITCCA will be issued within 90 calendar days of reconciliation.
- If consumption is less than projected, a bill for the difference between projected and actual consumption

plus applicable ITCCA will be issued. Payment must be received within 30 calendar days of receipt. Failure to satisfy the reconciliation bill will result in withholding of upfront allowance for future projects until payment is made in full. For main related projects, a monthly main ownership will be incurred and reduce the remaining refundable portion.

To mitigate reconciliation billing, SoCalGas has adopted a policy that withholds upfront allowance for non-residential space heating only projects and projects where it's known that meters will not be installed within the required timelines. Non-residential space heating-only projects will receive a refund up to the amount paid including ITCCA at the three-year reconciliation.

## 2.4 IMPORTANT TIMELINES FOR NATURAL GAS SERVICE LINE EXTENSION PROJECTS

To help applicants/builders better plan their construction schedules, the timelines in Figure 2 outline when to expect a contract for signature and when to expect the installation of the SoCalGas line extension project. Please note that construction start dates are only estimates and are subject to change. Equipment and material lead times, labor availability, regulatory approvals, right-of-way negotiations, and/or other unforeseen events could delay the actual construction start date. Construction start dates are also contingent on customer satisfying all of their obligations with respect to the project, including timely delivering all applicable agreements and payments related thereto.

**FIGURE 2 - Timelines for Contract and Start of Construction for New Natural Gas Line Extension**

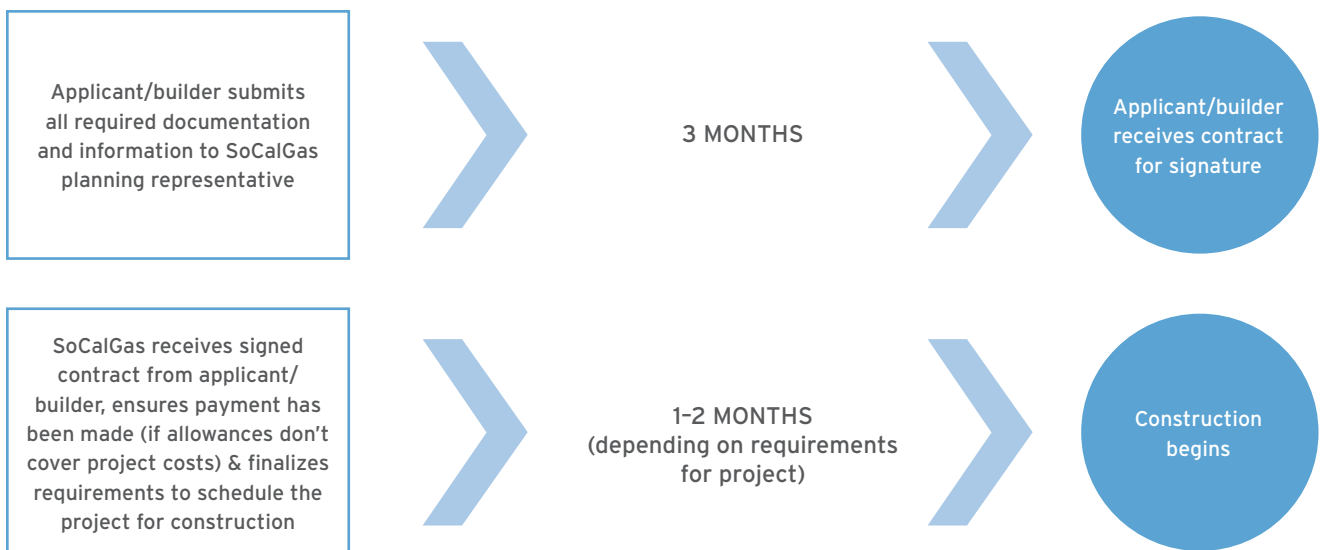



## 2.5 RELOCATION / ALTERATION OF EXISTING NATURAL GAS FACILITIES

Customers/builders should contact SoCalGas as early as possible when plans call for abandonment, relocation or alteration of existing service or meter set assemblies. To begin the process of submitting a request for relocation/alteration of an existing natural gas facility, access an online application at [www.socalgas.com/new-construction](http://www.socalgas.com/new-construction).

Your request will be assigned to a SoCalGas planner in your request area. The planner will arrange a site visit to review your request. For service abandonment requests, provide proof of a demolition permit and/or new building construction permit to the planner, and state if you plan to rebuild and require a new service for a new structure. The planner will discuss the various service options to meet your needs and develop a cost estimate for your approval/signature to serve those needs. No natural gas facility work can be scheduled or commence until full payment is received and recorded.

To reduce costs, applicants can provide their own service-trenching on their private property. Trenching requirements and guidance will be provided upon request.

Residential customers needing to upsize their existing meter because of the addition of new natural gas appliances will also need to submit an online application at [www.socalgas.com/new-construction](http://www.socalgas.com/new-construction).

## 2.6 SERVICE DESIGN AND INSTALLATION OPTIONS

Per [Rule 20 and Rule 21](#), applicants have the right to select either SoCalGas or a third-party SoCalGas-approved contractor to perform the natural gas service design, installation, and trenching. Upon applicant designation on the "Request for Service" application, SoCalGas will provide a bid for applicant design or installation costs. Specific conditions must be met to utilize an applicant design or install.

### 2.6.1. APPLICANT DESIGN

Per [Rule 20 and Rule 21](#), new natural gas line extensions may be designed by the applicant's qualified contractor or subcontractor in accordance with the Utility's designs and construction standards. The type of SoCalGas projects that can be designed by an applicant designer are: new, 3-inch and smaller diameter polyethylene (PE) main and services with no steel tie-in and operating at medium pressure (<60psig).

As [Rule 20 and Rule 21](#) indicate, if the applicant elects to utilize an applicant designer, it is the applicant's responsibility to ensure they sign the Applicant Design Terms and Conditions ([Form 6665](#)) and return it to [NewBusinessProcessTeam@socalgas.com](mailto:NewBusinessProcessTeam@socalgas.com). It is also the applicant's responsibility to ensure the applicant design work is performed by or under the direction of a licensed professional engineer and all designed work submitted to SoCalGas must be certified by an appropriately licensed professional engineer, consistent with the applicable federal, state, and local codes and ordinances.

SoCalGas requires every applicant designer to be certified and approved by SoCalGas. For an applicant designer to be certified and approved by SoCalGas:

- Applicant designer works with New Business Process ([NewBusinessProcessTeam@socalgas.com](mailto:NewBusinessProcessTeam@socalgas.com)) to:
  1. Receive training manual
  2. Pay for, schedule, and attend a 5-day applicant designer training at our Pico Rivera training center
  3. Pay for, schedule, and take pre-qualification test
  4. Ensure SoCalGas is named on Professional Errors and Omissions insurance
  5. Provide a copy of endorsement
  6. Provide name of appropriately-licensed professional engineer who will be certifying applicant designer's work

Once qualification requirements are met, applicant designer will be responsible for:

- Submitting plans required for land basing and planning to SoCalGas planning representative
- Submitting recorded grant deed, documentation showing who is authorized to sign documents relating to real estate matters on behalf of that entity, and recorded tract/parcel map or lot line adjustment to SoCalGas planning representative to process easement/right of way
- Creating construction sketch and substructure sketch for main installation
- Creating a material list for main installation
- Creating gas handling procedure for main installation
- Populating a service information sheet
- Creating service sketch

If interested in the applicant design process, please send an email to [NewBusinessProcessTeam@socalgas.com](mailto:NewBusinessProcessTeam@socalgas.com) and request the applicant design information packet.

## 2.6.2. APPLICANT INSTALL

Per [Rule 20 and Rule 21](#), new natural gas line extensions may be installed by the applicant's qualified contractor or subcontractor in accordance with the Utility's designs and specifications. The type of SoCalGas projects that can be installed by an applicant installer are: new, 4-inch and smaller diameter polyethylene (PE) main and services in open trench and operating at medium pressure (<60psig). To ensure a project stays within this scope, SoCalGas provides the installation materials to the applicant installer.

As [Rule 20 and Rule 21](#) indicate, if the applicant elects to utilize an applicant installer, it is the applicant's responsibility to locate and contract with a SoCalGas-approved applicant installer. SoCalGas requires every applicant installer to be certified and approved by SoCalGas. For an applicant installer to be certified and approved by SoCalGas:

- Applicant installer works with SoCalGas Applicant Installer Coordinator ([MCarigma@socalgas.com](mailto:MCarigma@socalgas.com)) to schedule, pay for, and attend plastic fusion training at either our Pico Rivera or Bakersfield training centers, and to process credit check
- Applicant installer works with SoCalGas' Operator Qualification team ([ContractorOpQual@socalgas.com](mailto:ContractorOpQual@socalgas.com)) to ensure 12 Operator Qualification tasks are/ have been completed in Veriforce®, a Drug & Alcohol Program is in place, and SoCalGas is protected
- Applicant installer works with New Business Process Manager ([NewBusinessProcessTeam@socalgas.com](mailto:NewBusinessProcessTeam@socalgas.com)) to schedule and attend as-built documentation training on Microsoft® Teams.

Contracts for applicant installation projects come in two parts. SoCalGas sends Part 1 of contract to applicant for signature which includes the Applicant Install Cover Sheet, Bid Letter (comparison of costs sheet), and [Form 66602](#). Once applicant returns Part 1 with signatures, they will receive Part 2 of contract which includes the Exhibit A (invoice). Upfront allowances are not granted on applicant install projects and will be granted at project reconciliation or with the extend stub project when allowance is generated. Additionally, an inspection fee is included in the project cost and is non-refundable.

Before construction of an applicant installation project, an inspector from SoCalGas will meet with the applicant installer to establish an inspection schedule and make arrangements to pick up material from a SoCalGas location. Responsibilities will also be covered, such as:

- Applicant installers install pipe and do not tie-in to live main

- Natural gas facilities installed by applicant installer must be placed into service within 120 days from the date of pipe installation
- Applicant installation is irrevocable and non-transferable (i.e. if applicant installer starts constructing a phase of the project then applicant decides they want to have SoCalGas do the installation instead, the applicant installer needs to finish the phase first as applicant install)
- Prior to receiving a future applicant install work order package, the applicant installer is responsible for completing and receiving approval from the SoCalGas inspector of all as-built documentation
- Applicant installer has 10 days after moving off job site to provide completed as-built documentation to SoCalGas inspector
- Applicant installers are to correct any errors on as-built documentation within 5 working days of receipt and change orders can be issued for excessive as-built document review

## SECTION 3 NATURAL GAS SERVICE

### 3.1 GENERAL REQUIREMENTS

A natural gas service lateral is the section of pipe that connects from the SoCalGas® distribution main in the public street or easement to the service riser located on the customer's premise. It is typically constructed of polyethylene (PE) pipe material although steel pipe is installed when required by ordinance, code or SoCalGas system integrity.



## 3.2 SERVICE LOCATION

Service lateral facilities shall extend:

- a) In public property - from the point of connection at the distribution main to the applicant's nearest property line along any street, highway, and easement which SoCalGas has or will install distribution main.
  - b) In private property - along the shortest, most practical and available route that is clear of obstruction (leakage patrol requirement) to reach the SoCalGas-agreed-to service delivery point. Avoidance of steep banks, excessive moisture, retaining walls, and plowed lands is encouraged.
- Services should be installed perpendicular to the source main. Diagonal or cross lot installations are not acceptable (See Figure 3).
  - Each natural gas service must have a shutoff valve located outside of a building in a readily-accessible location and cannot be in a privately-locked security area.
- SoCalGas does not permit service installation:
    - a) under or through buildings and retaining walls/ structures
    - b) directly into concrete or asphalt pavement materials
    - c) below underground structures, breezeways, concrete pads, wood decking, or carports
  - Riser spacing - Accurate finish grade and riser locations are necessary to complete the integrity of the natural gas installation. SoCalGas installation crews will install the natural gas risers to the location and grade that the applicant/builder provides.
  - Riser damage - Once a service and riser is installed to finished grade, any changes in location, finished grade or other reason resulting in an unsatisfactory location, all costs shall be borne by the builder/applicant. "Mini-riser vaults" (MRVs) (see Figure 4) are now installed as a corrective action, at the builder/ applicant's expense, to protect a riser in an unsatisfactory location.

**FIGURE 3 - Single Structure, Single Premise**

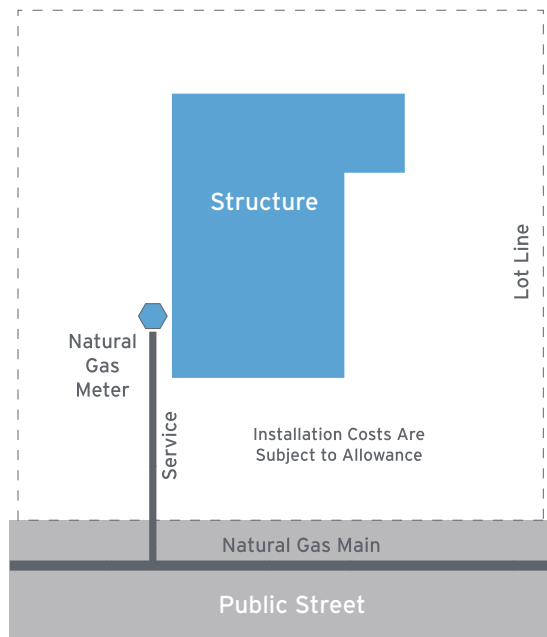

**FIGURE 4 - Mini Riser Vault (MRV)**

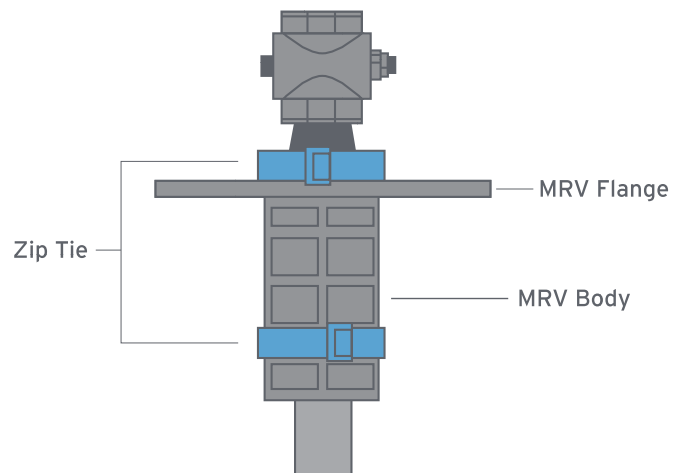

### 3.3 NUMBER OF SERVICES

- SoCalGas will not normally provide more than one Service lateral, including associated facilities, for any one building or group of buildings for a single enterprise on a single premise, except if required by:
  - a) Tariff Rules or Rate Schedules
  - b) Utility Convenience
  - c) Local Ordinance
  - d) Other - Utility can install additional services for customer benefit as a [Rule 2](#) special facility installation

#### SERVICE CONSTRUCTION EXAMPLES TO ILLUSTRATE ACCEPTABLE PRACTICES:

##### a) Residential - Two Dwelling Unit Structures with Vented Appliances/Single Premise

Generally, one service to each structure is provided; meters located at one location per structure. If space is limited and a meter easement can be obtained, one service with a meter manifold can be installed. Additional services to a single structure can be granted and are subject to allowance if it is determined by SoCalGas to best serve the structure at more than one location. Additional services for applicant benefit (minimizing house piping, proximity, etc.) may be installed but do not qualify for allowance and may be subject to [Rule 2](#) special facilities ownership charges.

**FIGURE 5 - Residential, Two Structures w/ Vented Appliances, Single Premise**

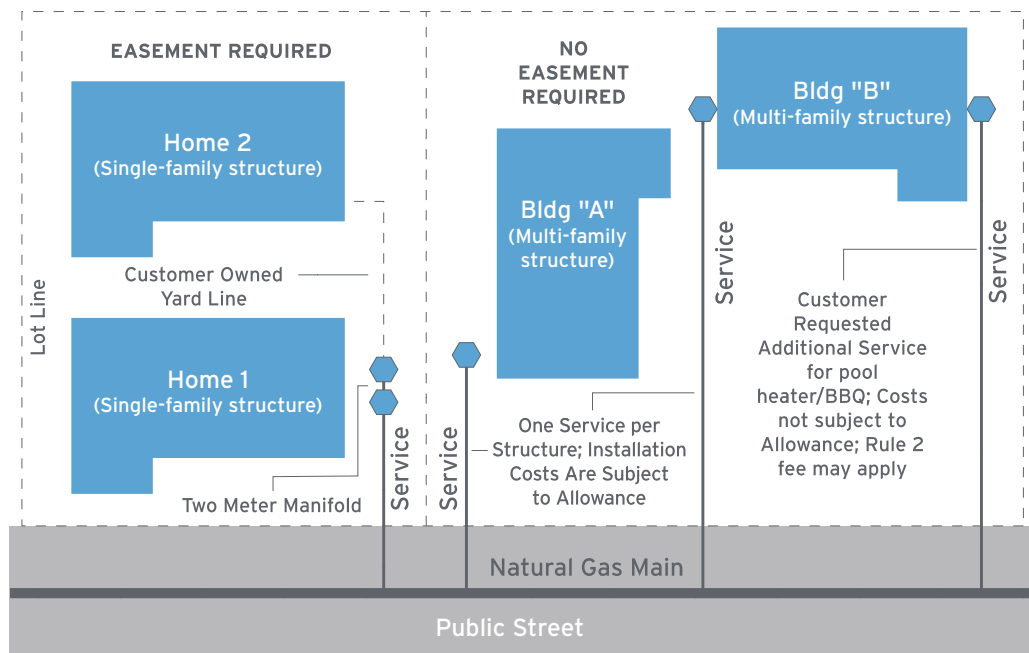

**b) Residential - Multi-family/Three or More Structures on a Single Premise with No Vented Appliances in each Dwelling Unit**

When three or more multi-family structures are on the same premise and do not have individual vented appliances serving each dwelling unit (central water/space heating serves all units in common), SoCalGas may install a natural gas distribution main and a single individual service and meter to each structure provided the following conditions are met:

- a. An accessible and protected location exists for SoCalGas use
- b. An easement, right-of-way, or permit to install natural gas facilities on the premise at no cost to SoCalGas

Additional services to a single structure can be granted and are subject to allowance if it is determined by SoCalGas to best serve the structure at more than one location. Additional services for applicant benefit (minimizing house piping, proximity, etc.) may be installed but do not qualify for allowance and may be subject to [Rule 2](#) special facilities ownership charges. Additionally, a single service with individual natural gas meters may be requested for structures where dwelling units do not have vented appliances. For further information, please see Section 4.2.1 - Individual Meters Versus Master Meter -Vented Appliances.

**FIGURE 6 - Residential - Multi-family/Three or more Structures on a Single Premise with No Vented Appliances in Each Dwelling Unit**

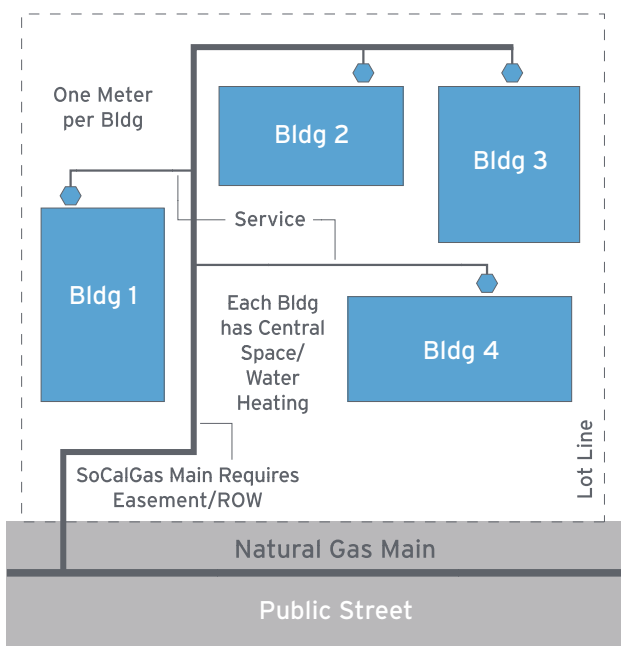

**c) Residential - Multi-family/Three or More Structures on a Single Premise with Vented Appliances in each Dwelling Unit**

When three or more multi-family structures are on the same premise and have individual vented appliances serving each dwelling unit, SoCalGas will serve each building with individual meters but requires an easement/right-of-way (ROW) for main installation.

Additional services to a single structure can be granted and are subject to allowance if it is determined by SoCalGas to best serve the structure with individual meters at more than one location. Additional services for applicant benefit (minimizing house piping, proximity, etc.) may be installed but do not qualify for allowance and may be subject to [Rule 2](#) special facilities ownership charges.

**FIGURE 7 - Residential - Multi-family/Three or more Structures on a Single Premise with Vented Appliances in Each Dwelling Unit**

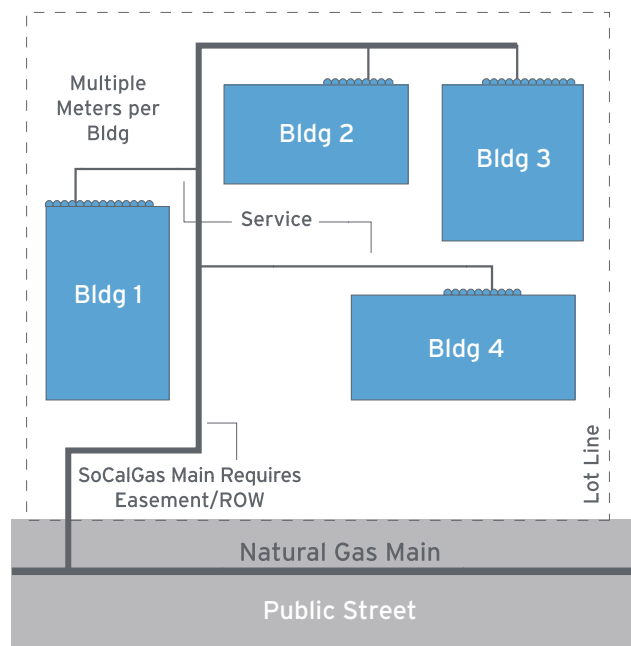

**FIGURE 8 - Service - Residential, Multi-family Single Structure, Multiple Legal Property Lines**

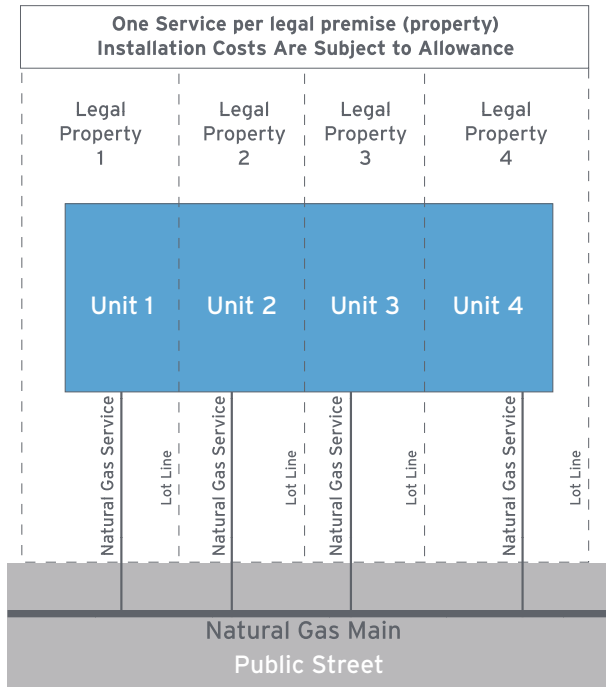

**FIGURE 9 - Multi-family Residential Single Structure, Single Premise**

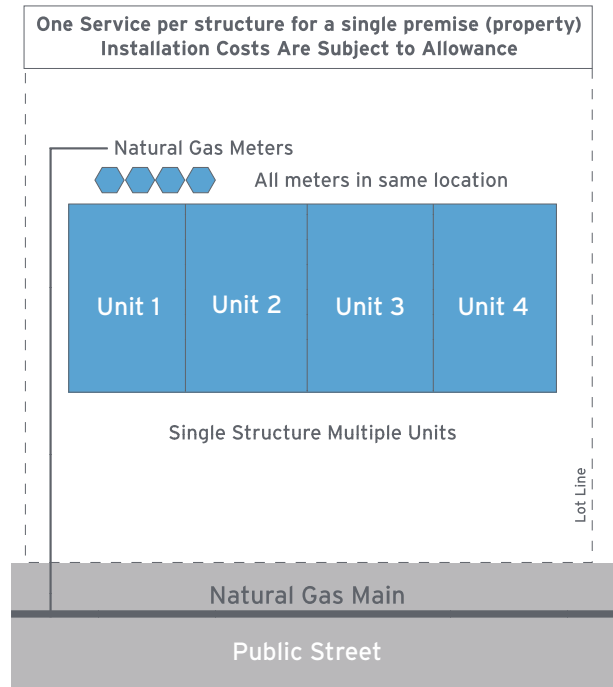

**d) Residential Contiguous Dwellings (Condos/ Townhomes) (single structure)**

- i. If each dwelling unit is bounded by its own legal property lines on the same parcel, then a separate service is required for each dwelling unit and located within the serving property. See Figure 8.
- ii. If each dwelling unit is divided by assumed property lines, then dependent upon agency inspection/ approval, SoCalGas will either serve with individual services (if required for agency approval) or through one service serving a meter bank (preferred). If required by agency for approval, the builder must obtain easements for houselines that cross assumed property lines from the governing agency before SoCalGas will install natural gas meter facilities. See Figure 9.

**e) Single Non-residential Enterprise, Single Premise with Multiple Structures**

One service per premise capable of serving the permanent, bona fide load. Additional services can be provided and are subject to allowance and [Rule 2](#) special facilities ownership charges. See Figure 10.

**f) Multiple Non-residential Enterprises on a Single Premise in a Single Structure (Strip Mall or Spec Building)**

**FIGURE 10 - Single Non-residential Enterprise, Single Premise, with Multiple Structures**

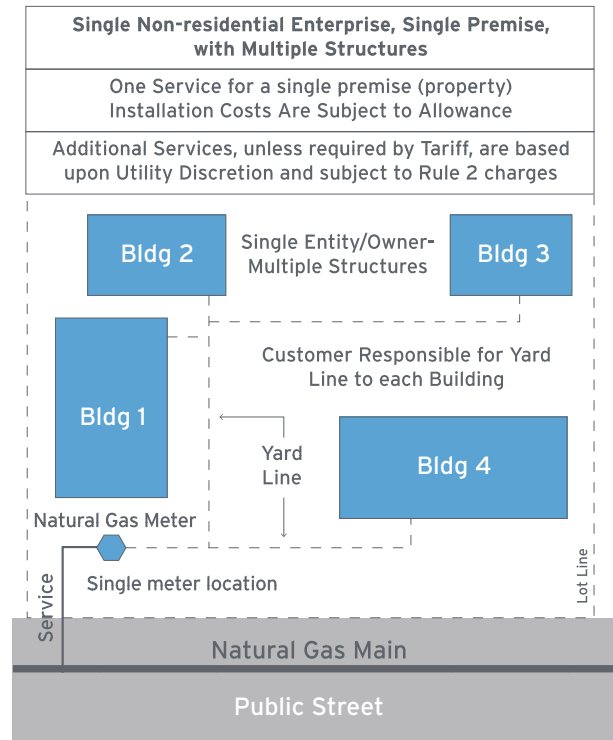

**FIGURE 11 - Multiple Non-residential Enterprises on a Single Premise, Single Structure**

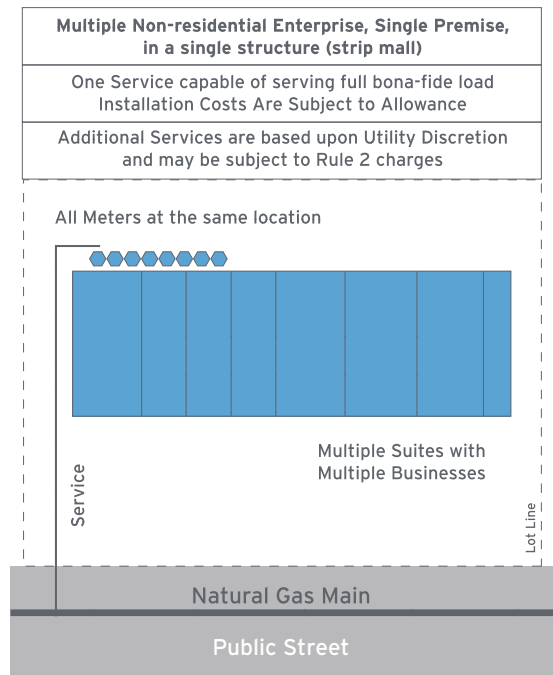

One service is capable of serving the permanent, bona fide load. A second service can be installed and is subject to allowance depending upon the utility's discretion (reduces utility cost to serve).

No upfront allowance will be granted when bona fide load is unknown or for space heating only.

Actual consumption or earned allowance will be issued as a refund at the 3 year reconciliation (3 years from the first meter turn-on date).

**g) New - Mixed-use (Residential/Non-Residential), Single Premise, Single Structure**

One service is capable of serving the total permanent, bona fide load.

Customer-requested additional services can be granted; however, incremental allowance will be capped at SoCalGas' obligated cost to serve the load. In addition, the incremental cost will be borne entirely by the customer and is non-refundable, fully-collectible and subject to [Rule 2](#) special facility ownership charges.

For existing non-residential customers who request additional services and have multiple existing services serving a single enterprise on a single premise, the collective delivery capacity (CDC) will be used to determine load sufficiency. If the CDC can meet the incremental load, then no incremental allowance will be applied. The total cost will be borne by the customer including any non-refundable [Rule 2](#) special facility ownership charges. If the CDC cannot meet the incremental load, then an additional service will be provided with allowance.

## 3.4 EXCESS FLOW VALVES AND CURB VALVES

An excess flow valve (EFV) is a device installed underground on the natural gas service line designed to limit the flow of natural gas to a predetermined level if there is a complete break in the service line. If tripped, the EFV has a bypass feature that automatically resets the valve once the service line is no longer leaking and pressure equalizes across the valve.

An EFV is required on all new and/or replaced natural gas service installations per Code of Federal Regulations (CFR) 49 Parts 192.381 & 192.383. A manual service line shut-off valve, or curb valve, may be installed in lieu of an EFV when the total load of the service line is greater than 1,000 CFH.

## 3.5 TRENCHING

SoCalGas is the default provider of trench for the natural gas facility installation. However, [Rule 21](#) has provisions that allow builder/applicants to provide their own trench with the potential to receive credit if allowance exceeds total cost. The following are guidelines for applicant-provided trench. Your SoCalGas planner will provide further details if needed, and if you are looking to provide a trench, please read section 2.3.4. STEP 4 - CONSTRUCTION for more information on what is required for the trencher to be qualified.

### General

- The entity providing the trench is considered the trench owner and is responsible for all local ordinance, permit and resurfacing.
- The trench must comply with CPUC and DOT regulations and with SoCalGas trench specifications.
- Only dry utilities (power, telephone, CATV, street lighting) are allowed in joint trench with natural gas.
- No wet utilities (water/sewer/landscaping) are allowed in a joint trench.

### Separation from Natural Gas Pipe/Line

- For natural gas main installation, at least 60" of undisturbed earth must separate a dry utility trench from a wet utility trench. For natural gas service installation, the separation from a wet utility trench must be at least 24". If sandy soil conditions do not allow the native soil to remain undisturbed between the trenches, then casing (sleeve) is required for the natural gas line, or a minimum of 36" separation and no casing (sleeve). Note: "undisturbed" means the earth/soil has been unaltered or has obtained maximum compaction density and stability through backfill and compaction and will not shift or settle from natural weather cycles.

- f) Power/electric, CATV, telephone, and other dry substructures within the joint trench, a minimum of 12" of separation in all directions when natural gas pipe/line has a diameter of 4" or smaller and does not contain arc welds. Minimum separation increases as diameter increases and when there are arc welds. Please work with SoCalGas planning representative on obtaining appropriate separation requirements in these cases.

**Depth or Cover over Natural Gas Pipe/Line for New Installations**

- g) 30" minimum cover on private property (24" if conditions warrant - SoCalGas approval required).
- h) 30" minimum cover to finished grade when behind curb (parkway) in public easement.
- i) 30" minimum cover to finished grade (flow line) when in street (between curbs) in public easement.
- j) 32" minimum cover for 4-inch and larger diameter pipe.
- k) 42" maximum cover to finished grade in street/public easement.

**Trench Width for Service Natural Gas Pipe/Line**

- l) 18" minimum width for 2" or smaller diameter natural gas-only pipe trench
- m) 24" minimum width for greater than 2-inch natural gas-only pipe trench

- n) 18" minimum width for 5 feet from coupling
- o) 24" minimum width at service to main connection

**Bedding for Service Natural Gas Pipe/Line**

- a) 6" minimum bed of rock and debris-free sand (screened sand)

**Backfill Material for Natural Gas Pipe/Line**

- b) 12" minimum cover of rock-free sand (screened sand) over natural gas pipe in normal soil
- c) 18" minimum cover of rock-free sand (screened sand) over natural gas pipe in rocky soil
- d) Native back fill is encouraged to complete backfill

**Warning Mesh**

- e) SoCalGas requires a warning mesh to be installed at a minimum of 12" above its natural gas pipeline for pipeline operating at 60 PSIG or below, and 18" above natural gas pipeline operating above 60 PSIG.

**Casing**

- f) A SoCalGas planning representative will provide the requirements for the encasement of carrier pipe at street crossings. Per Tariff Rule 20, where requested by builders/developers and mutually agreed upon, SoCalGas may furnish and install the casing (sleeves) provided this work is included in the total estimated cost on the line extension contract.

**FIGURE 12a - SoCalGas Distribution Main Joint Trench Diagram (Typical Examples)**

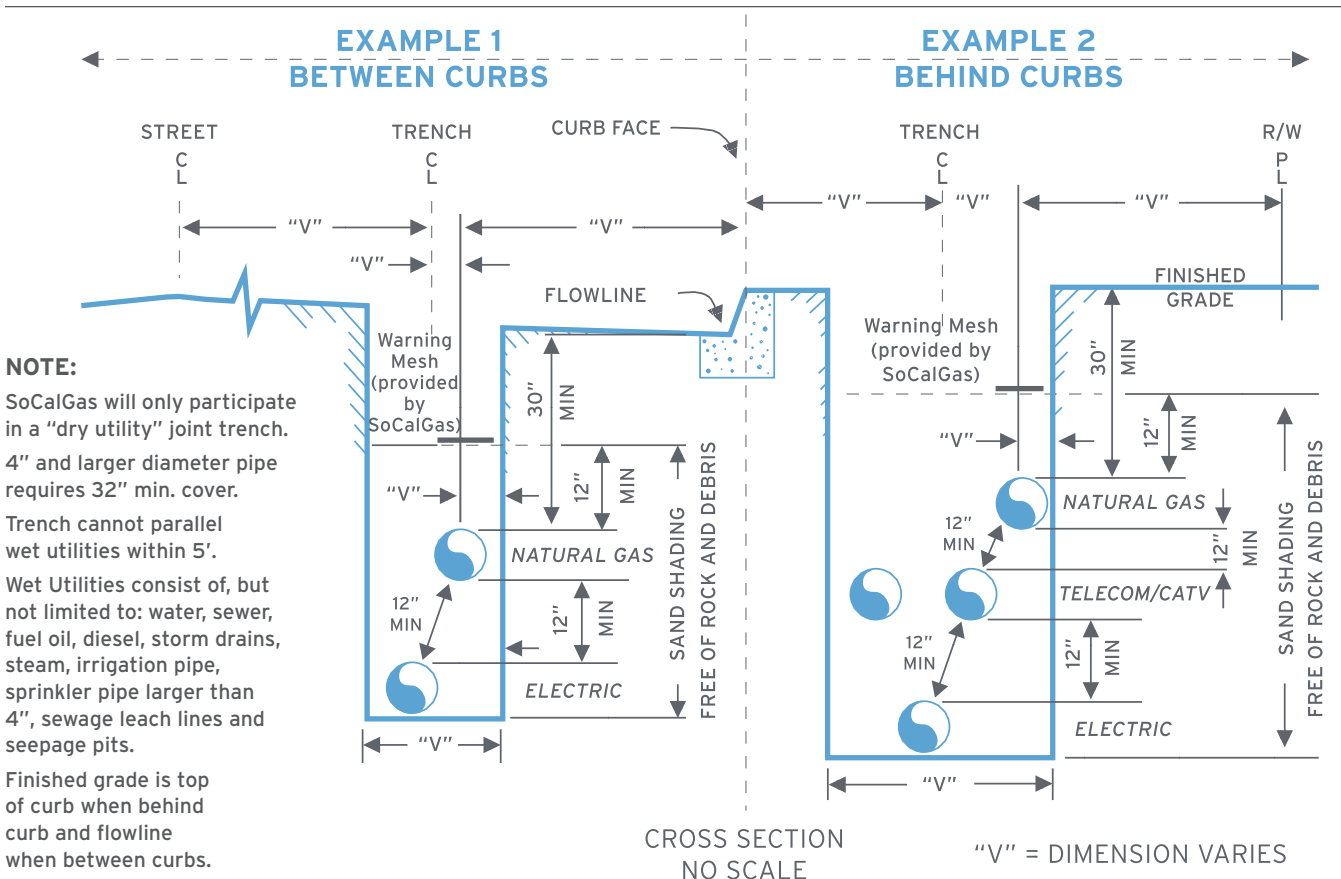

**FIGURE 12b - SoCalGas Distribution Service Joint Trench Diagram (Public and Private Property Cross Sections)**

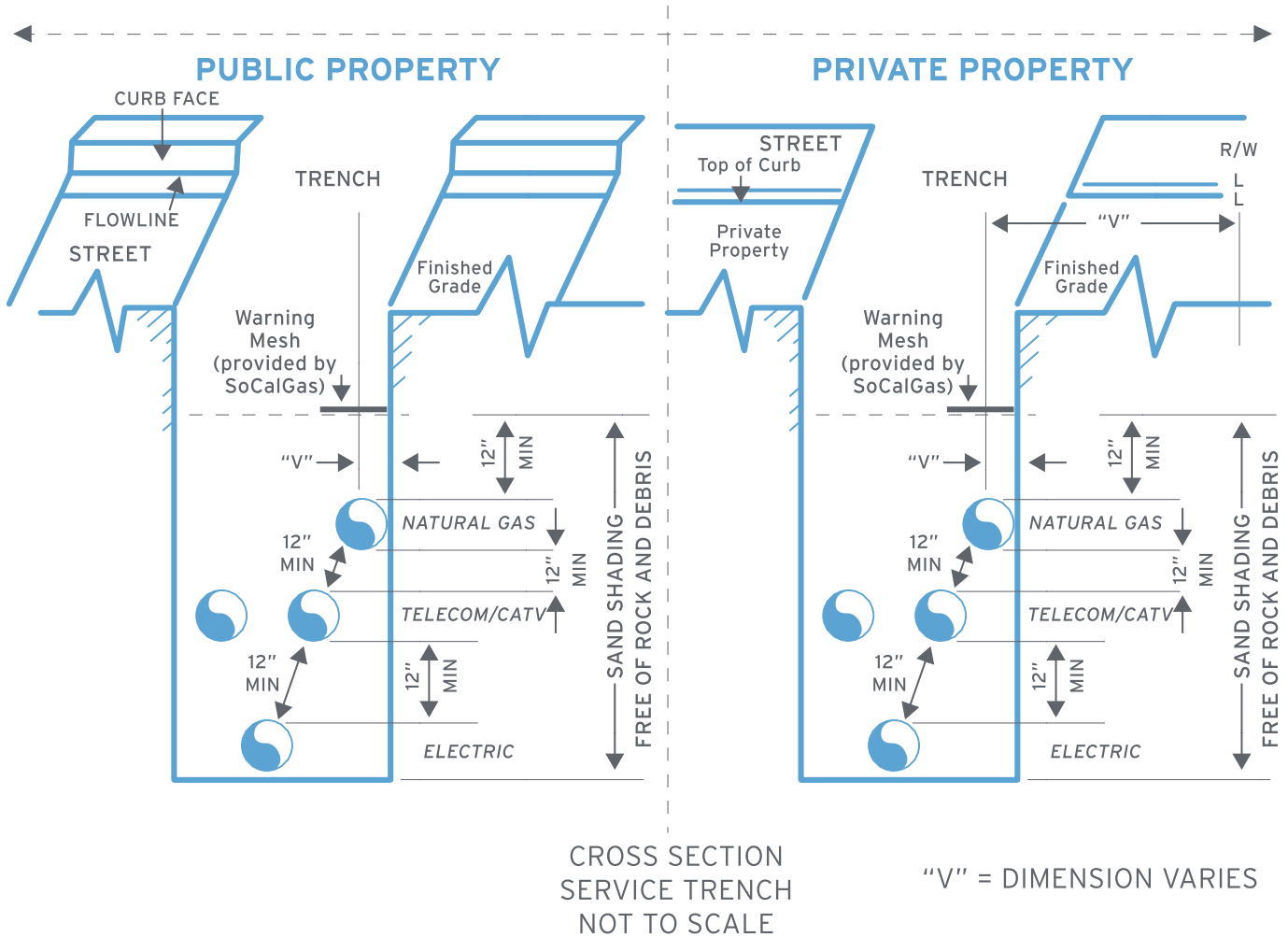

**NOTE:**

SoCalGas will only participate in a "dry utility" joint trench.

24" minimum horizontal separation from wet utilities i.e., water, sewer, landscaping sprinklers and/or irrigation pipes, drains, sewage leach lines, or seepage pits.

For wet utilities, if sandy soil conditions do not allow the native soil to remain undisturbed between the trenches, then a sleeve will be required for the natural gas line, or a minimum of 36" separation and no sleeve. Note: "undisturbed" means the earth/soil has been unaltered or has obtained maximum compaction density and stability through backfill and compaction and will not shift or settle from natural weather cycles.

Finished grade is top of curb when behind curb and flowline when between curbs.



### 3.6 BRANCH SERVICES

A branch service is a pipe that branches off a natural gas service or standard pipe. A branch service is typically installed between two adjacent residential structures that front the same street and have meter locations adjacent to one another. An easement or right-of-way (ROW) is required for all cross-lot branch services.

SoCalGas limits the use of cross-lot branch service installations due to property disputes among owners, potential damage from property line fencing, and potential service capacity issues.

If a cross-lot branch service is the only feasible method to serve your property, SoCalGas will attempt to contact your neighboring property owner to obtain an easement/ROW prior to finalizing planning and construction. If the owner is unresponsive or does not wish to honor our request, it is the builder/applicant's responsibility to pursue the matter further. SoCalGas will not install a cross-lot branch service without an easement.

As a note, SoCalGas cannot force reluctant neighboring property owners to authorize an easement/ROW nor will SoCalGas participate in any legal contract or dispute mitigation that develops as a result.

Below is an example of a residential branch service arrangement.

**FIGURE 13 – Branch Service Diagram**

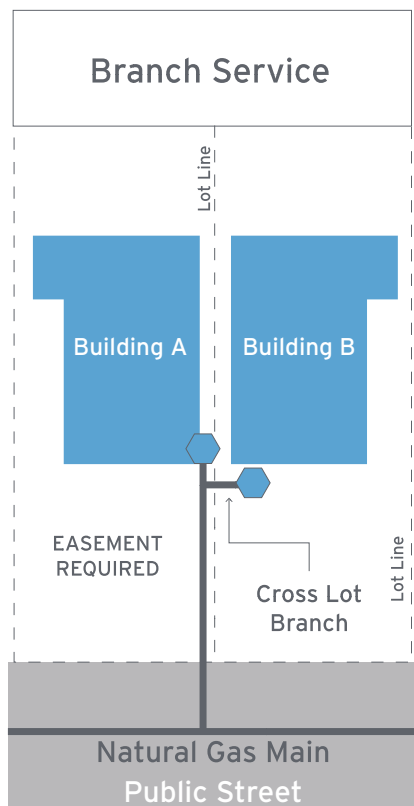

## SECTION 4 NATURAL GAS METER SET ASSEMBLIES (MSA)

### 4.1 MSA FEATURES

A natural gas meter set assembly (MSA) generally consists of the following features:

- Natural gas meter
- Service regulator
- Natural gas shut-off valve (additional valves installed if required)
- Bypass tee fittings to facilitate SoCalGas maintenance of the MSA

When required especially for high volume MSAs, SoCalGas® will install filtration, additional by-pass capabilities, monitor regulation, and various other equipment necessary to ensure safety and natural gas measurement accuracy.

### 4.2 NUMBER OF METERS

SoCalGas will normally install only one meter for a single family residence or a single non-residential enterprise on a single premise, except:

- When otherwise required or allowed under SoCalGas Tariff Rules (see [Rule 20 and Rule 21](#))
- At the option of and as determined by SoCalGas Engineering for its operating convenience
- When required by law or local ordinance
- When additional services are granted by SoCalGas under the [Rule 2](#) provisions

#### 4.2.1. INDIVIDUAL METERS VERSUS MASTER METER - VENTED APPLIANCES

Per [Rule 13](#), SoCalGas is obligated to individually meter all new multi-unit residential structures where multi-tenants use natural gas directly in natural gas appliances that individually serve each occupancy and which require venting.

CPUC defines natural gas appliances that require venting as those that require venting for combustion product purposes. Space heating (furnaces, a fireplace that provides the dwelling units' sole source for space heating, etc.) and water heaters (conventional tank or tankless) require venting for combustion purposes- see Public Utilities Code, Section 780.5. <http://codes.findlaw.com/ca/public-utilities-code/puc-sect-780-5.html>

A single natural gas meter (master meter) can serve an entire multi-unit complex in which the natural gas is used only for central water/space heating purposes that supply all tenants in common or in which each unit has its own natural gas cooking and/or natural gas laundry (clothes drying). Individual meters, in addition to the master meter, may be requested for individual dwelling units with no vented appliances.

#### 4.2.2. RESALE OF NATURAL GAS (SUB-METERING)

“Sub-metering,” by definition, is a system that allows a landlord to bill tenants for individual measured utility usage through the installation of customer owned sub-meters. Per [Rule 24](#), only a Utility can bill a customer for energy consumption and a landlord shall not charge their tenants for natural gas received through a single meter except where the cost of natural gas is absorbed in the rent for each individual tenant and the monthly rent does not change due to the natural gas consumption of each individual tenant. [Rule 24](#) prevents landlords/customers of residential and non-residential properties from installing sub-meters for billing purposes unless they become a utility and comply with all of the state regulatory and billing compliance requirements.

Non-Residential applicants/customers are allowed to install sub-meters on their houeline, and for new residential construction, customer owned sub-meters on houeline is allowed provided [Rule 13](#) is also not impacted. Per [Rule 13](#), as long as there are no vented appliances within the individual dwelling units, which requires SoCalGas to install individual SoCalGas meters, and the builder/applicant complies with the conditions as it relates to [Rule 24](#), sub-meter installation on houeline is acceptable. Additionally, the applicant/customer/landlord must follow the requirements outlined in Sections 5-9 of this guidebook and in the [California Plumbing Code/Uniform Plumbing Code](#) for applicant owned piping (houeline) and placement of sub-meters in safe locations.

### 4.3 PRESSURE

#### 4.3.1. STANDARD DELIVERY PRESSURE

Per [Rule 2, Section 3 - Pressure](#), SoCalGas provides natural gas service pressure to the service delivery point at 8" water column or approximately 1/3 psig as measured at the MSA's natural gas outlet.

#### 4.3.2. ELEVATED DELIVERY PRESSURE

Per [Rule 2](#), for connected loads of 1 million BTU/hour or greater, SoCalGas will deliver elevated pressure upon request and acceptance at the following elevated pressures:

- Two pounds
- Five pounds

- Service at as-available fluctuating pressures from the point of service
- Such other pressure as agreed upon by SoCalGas and the customer

As indicated on the “as-available” elevated delivery pressure letter, SoCalGas reserves the right to reduce the natural gas service pressure to either a lower elevated pressure or standard delivery pressure, without liability, when:

- It is determined that the elevated natural gas pressure will no longer be available
- Current delivery pressure is detrimental to SoCalGas' natural gas distribution system

#### 4.3.3. SINGLE-FAMILY RESIDENTIAL ELEVATED DELIVERY PRESSURE

For single-family residential construction, SoCalGas offers an elevated pressure program that enables developers to reduce plumbing costs by receiving elevated pressure at 2 psi. For more information, please visit: [Residential New Construction 2 PSIG Program](#). For single-family residential elevated pressure requests at 5 PSIG, there is a greater criterion (over 400' of yard line required, 4" or greater diameter yard line at standard delivery required to meet load, etc.) than [Rule 2](#)'s 1 million BTU/Hr of connected load requirement. It is evaluated on a case-by-case basis by SoCalGas Gas Operations. Builders/applicants/plumbers should never presume its availability. A [Rule 2](#) special facility ownership charge may be assessed if pressure is needed for appliance operation but fails to meet the residential pressure criterion.

#### 4.3.4. MULTI-FAMILY RESIDENTIAL ELEVATED PRESSURE PROGRAM (2 PSIG DELIVERY)

For multi-family residential construction, SoCalGas offers an elevated pressure program that enables developers to reduce plumbing costs by receiving elevated pressure at 2psig. For more information, please visit the following link: [Residential New Construction 2 PSIG Program](#)

#### 4.3.5. ELEVATED PRESSURE HOUSELINE VERIFICATION - AGENCY APPROVAL

Prior to natural gas delivery, builder/applicants are responsible for obtaining the appropriate houeline approval and SoCalGas must receive notification of the approval from the local governing agency. Once received, the SoCalGas planner will release the job for meter set scheduling. Meter set scheduling is not performed by the planner or the planning office. Builders must verify with the local governing agency to confirm that notification has been sent to SoCalGas. SoCalGas will not contact the building agency to determine houeline notification status or submittal.

## 4.4 METER LOCATION

### 4.4.1. GENERAL REQUIREMENTS

SoCalGas operates with multiple CPUC-governed electric service providers (PG&E, Southern California Edison, San Diego Gas and Electric) as well as several municipal electric service providers (LADWP, City of Anaheim, City of Glendale, etc.) each of which has unique and conflicting meter clearance requirements. In the past, SoCalGas has avoided establishing a single specific meter location requirement guideline to enable applicants to meet the electric service needs.

However, the following basic meter location requirements are consistent and must be maintained for all new SoCalGas natural gas meter installations.

SoCalGas requires all meter set assembly (Meter, riser, fittings, etc.) locations to be:

- Protected from vehicular damage or other potential hazards (corrosive environment, etc.) either by location or engineered/installed protection when:
  - Meter set assembly is on a residential site (i.e., any single-family residence or duplex) and is within 3 feet of:
    - Parking/garage spaces
    - Residential driveways
    - Commercial refuse containers
    - Paved areas with curbs
  - Meter set assembly is on a non-residential site (i.e. any commercial, industrial, government building, church, hospital, school, place of public gathering, multi-unit residential housing with more than two units) and is within 10 feet of:
    - Non-residential driveways without SoCalGas-approved protection
    - Freight or shipping docks
    - Paved areas without curbs
  - When located away from the serving structure:
    - Follow the guidance in Figure 14 - Meter Locations - Distance from Roadways
- 36" (measured radially from the regulator vent point of termination) of a source of ignition. Sources of ignition include, but not limited to:
  - Electric meter
  - Electrical outlet (explosion proof electric outlets excluded)

- Air conditioner condenser
- Communications enclosure, cable box, telephone box
- Any other electrically-powered device
- To enable operation and maintenance; require and maintain an unobstructed, flat and level working space in front of the MSA, at least 48" measured from the structure wall face (see Figure 17 and 18). If 48" is not available, please work with SoCalGas.
- Meter set assembly (meter, riser, fittings, etc.) cannot be placed within eight horizontal feet (96") of a mechanical air intake (see Figure 17). Examples of mechanical air intakes include, but are not limited to, window air conditioners/fans and swamp coolers.
- For most typical single-family residences, customer houelines would be located 11 to 19" horizontally from the natural gas riser depending upon meter capacity (see Figure 17).
- If potential hazards, unsafe conditions or access limitations exist, SoCalGas may locate the meter at or near the property line or away from the hazard. SoCalGas planners will determine the appropriate location after pre-construction site inspection.
- The meter location shall be evaluated in regard to traffic proximity to provide the least potential for damage by vehicles. See Figure 14.
- Roadway descriptions can be referenced on the [California Road System \(CRS\) Maps website](#)
  - Local roadways are considered small residential.

### 4.4.2. METER PROTECTION

For new business installations, the applicant, builder, or developer is responsible for installing meter protection. Meter protection is required where aboveground meter set assemblies (MSA) are within three feet of driveways, roadways, alleys, parking stalls, wheel bumpers, trash collection areas and areas where industrial equipment (forklifts, loaders, etc.) may operate. See Section 4.4.1.

Meter protection may be used in conjunction with manmade barriers such as wing walls, planters, steps, fences, and fireplaces to provide adequate protection to the MSA. See Figures 15 and 16 for guidelines on protection post installation and spacing. SoCalGas planners will determine the proper type of protection needed for your application.

**FIGURE 14 – Meter Locations – Distance from Roadways**

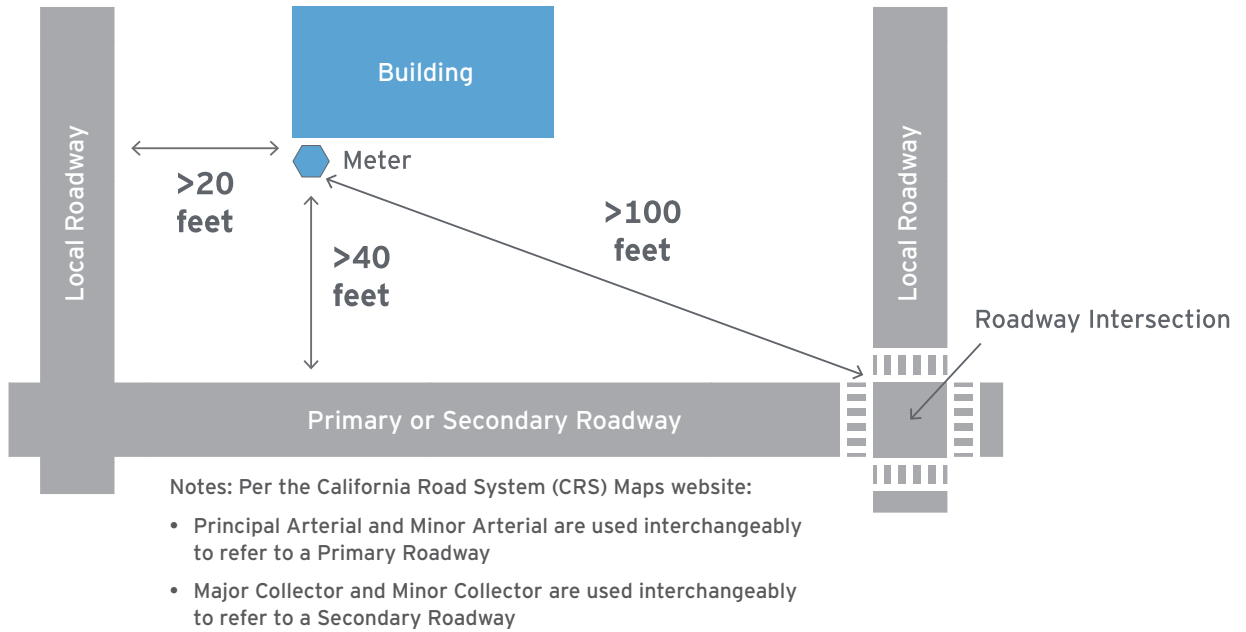

**FIGURE 15 - Typical Protection Post Installations**

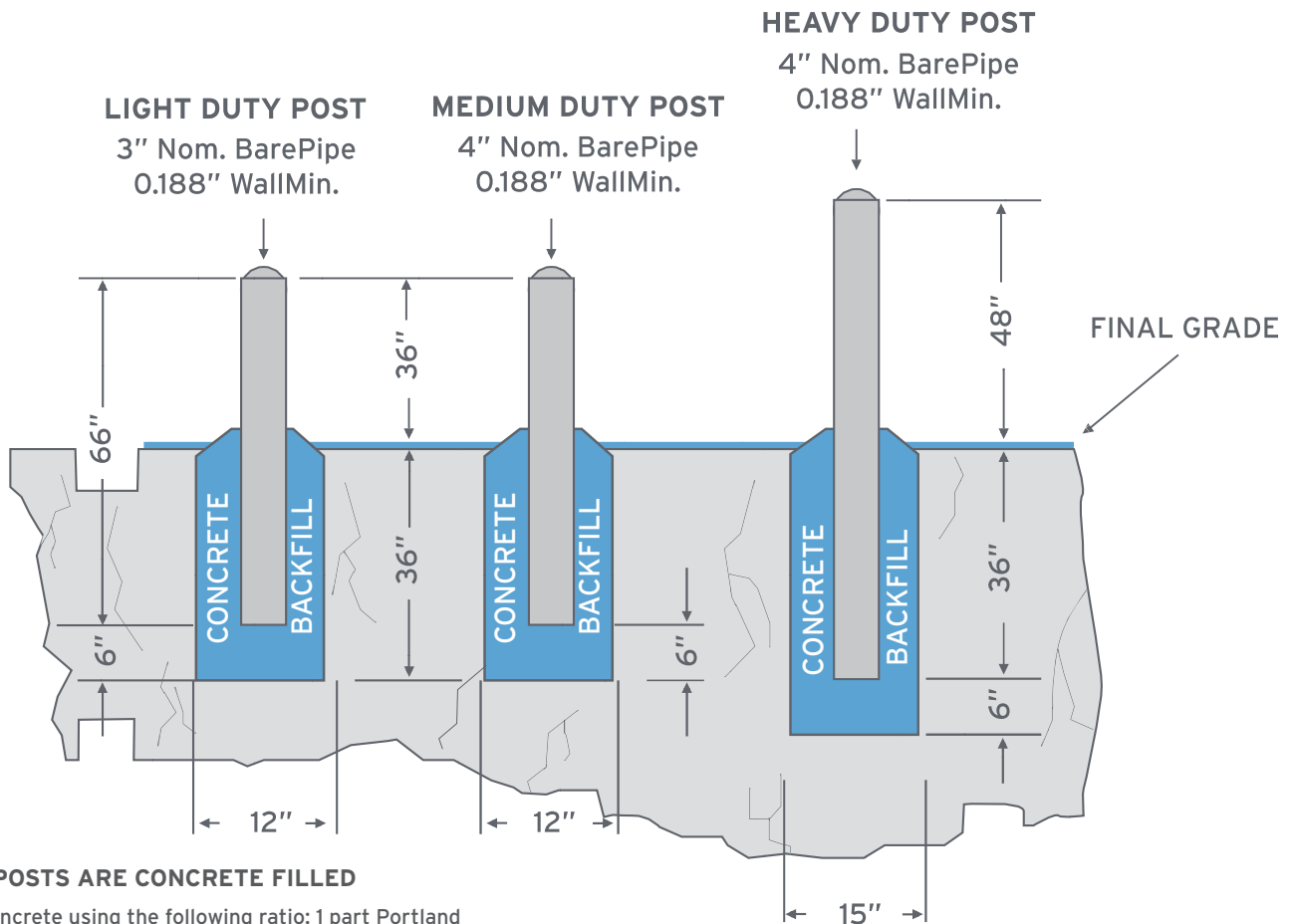

**ALL POSTS ARE CONCRETE FILLED**

Mix concrete using the following ratio: 1 part Portland cement, 2-1/2 parts sand, 3-1/2 parts gravel, or 5 sacks commercial ready-mix. Maximum water content is 4.66 gallons per 60 lbs. sack or 7 gallons per 90 lbs. sack of commercial ready-mix. Use 3/8" to 3/4" gravel.

**FIGURE 16 - Offset and Spacing of Protection Posts**

OFFSET AND SPACING OF PROTECTION POSTS			
Width of MSA ("A")	No. of Posts Required	Offset From Face and Corner of MSA ("B") Max. 26"	Spacing of Posts ("C")
24" to 52"	3	"A"/2 (14" Min. Light & Medium duty) (18" Min. Heavy duty)	2 x "B"
52" to 104"	4	"A"/4 (14" Min. Light & Medium duty) (18" Min. Heavy duty)	2 x "B"
104" to 156"	5	"A"/6 (14" Min. Light & Medium duty) (18" Min. Heavy duty)	2 x "B"
156" to 208"	6	"A"/8 (14" Min. Light & Medium duty) (18" Min. Heavy duty)	2 x "B"

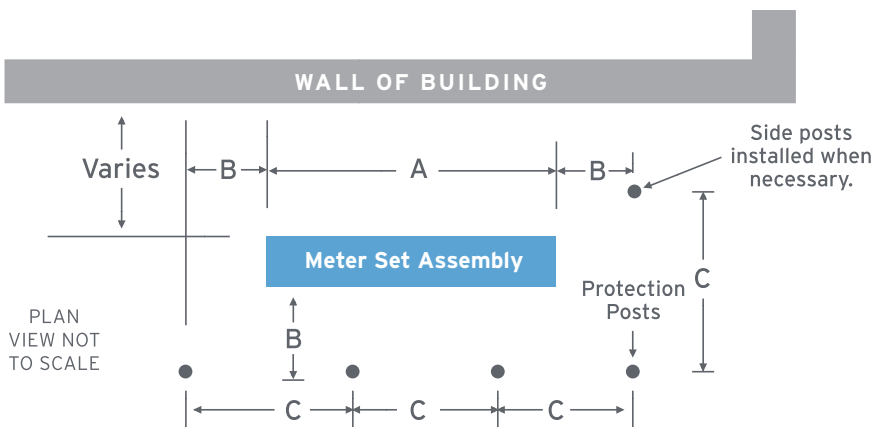
**EXAMPLE:**

MSA is 84" wide. **"A" = 84"**

To find "B", use second row of Table (52" to 104") Four posts are required. 84" divided by 4 posts = 21". **"B" = 21"**  
**"C" = 2 x "B". "C" = 42."**

**Result:** Set three posts, 21" offset, on 42" centers.

**4.4.3. PREFERRED METER LOCATION**

SoCalGas prefers meter installations to be:

- Outside, aboveground, and as close to the front of the structure as practical (typically within five feet of the structure's front wall but not closer than one foot from the front edge), provided there is little likelihood of damage by vehicles. See Section 4.4.1. for more information.
- In a ventilated recess or enclosure provided by the developer and approved by SoCalGas. The enclosure must have a vapor proof seal. See Section 4.10 for more information.

**4.4.4. DISCOURAGED METER LOCATIONS -SOCALGAS APPROVAL REQUIRED**

SoCalGas discourages the following meter locations but may accept them when no other acceptable location for access and safety is reasonably available:

- Curb meter vaults.
- Avoid locations inside carports or garage areas in or under buildings, except where there is no other satisfactory location, and then only if the customer provides a guard rail or other adequate protection from damage for the meters and service riser.
- On the wall of a building where meter dials are more than six feet above the ground level or above the ground floor of a building.
- Outside of a structure on a side where less than three feet exists between the foundation of the building and the lot or property line, except for an approved, ventilated, recessed opening in the wall of a building.
- In any location where it would be unsafe or subject to damage unless adequate protection is provided by a guard rail or fence. This protection must be provided by the builder/applicant or developer.
- Meters in vaults, operating at higher than standard delivery pressure.
- Under exterior stairways.
- New MSA installations within six feet of masonry-type chimney.
- Natural gas meter rooms (see Section 4.11).

### 4.4.5. PROHIBITED METER LOCATIONS

SoCalGas prohibits the following meter locations:

- Boiler room, heater room, engine room, electric meter room, elevator shaft or any room housing elevator machinery or equipment.
- In the same room or enclosure with any source of ignition or heat which may damage the meter unless meter is in a ventilated location and regulator vent point of termination is more than three radial feet away from the source of ignition or heat. See meter room requirements in Section 4.11.
- In living quarters or in a closet, under interior stairways, bathroom, shower room, or toilet room in any building. See Section 4.11 for meter room requirements.
- Any location where corrosive substances may contact any natural gas facilities (meter, riser, piping, regulation, etc.) or impede meter operation.

- Within eight horizontal feet of mechanical air intake. Examples of mechanical air intakes include, but are not limited to, window air conditioners/fans and swamp coolers.
- Under outside fire escapes.
- In any unvented location, or any location inside or out, where the regulator vent point of termination is closer than three radial feet from a source of ignition.
- Locations under electric meters.

## 4.5 SINGLE-FAMILY RESIDENTIAL METER CONFIGURATIONS

For single-family residential meters, please refer to the SoCalGas single-family residential natural gas meter set separation and clearance guidance diagrams for a graphical representation of meter separation requirements (see Figures 17 and 18). Your SoCalGas planner will advise of additional spacing requirements as it varies based upon load.

**FIGURE 17 - New Single Residential Natural Gas Meter Set Separation and Clearance Guidance Diagram**

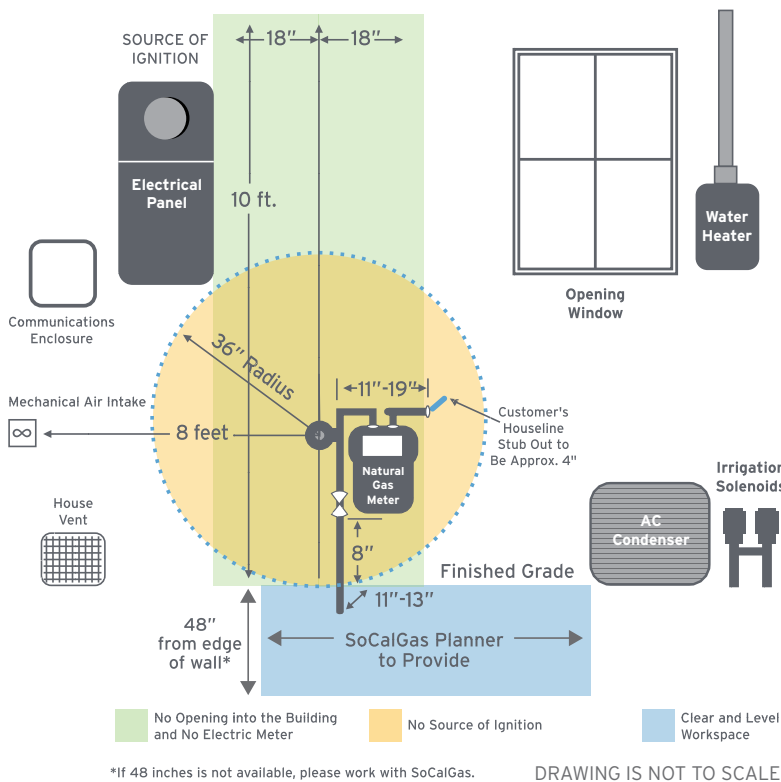

- Required for Single Residential Meters,
  - Houseline is located 11" to 19" from natural gas riser – varies based upon load
  - SCG typically installs risers at 11" to 13" out from building
- All Sources of Ignition shall be located more than 3 radial feet from regulator vent point of termination, per National Fuel Gas Code (NFPA) 54. Electric meters are also not permitted in the No Opening into the Building zone. Sources of ignition include, but are not limited to: electric meter, electrical outlet (explosion proof electric outlets excluded), air conditioner condenser, communications enclosure, cable box, telephone box, and any other electrically-powered device.
- Only fixed non-opening windows can be installed within 18" from either side of the regulator vent point of termination and 10 feet high from finished grade.
- Mechanical air intake cannot be within 8 horizontal feet from regulator vent point of termination. Examples include, but are not limited to, window air conditioners/fans, swamp coolers.
- SoCalGas operates with multiple CPUC-governed electric service providers (PG&E, Southern California Edison, San Diego Gas and Electric) as well as several municipal electric service providers (LADWP, City of Anaheim, City of Glendale, etc.) each of which has unique and conflicting meter clearance requirements. It is the responsibility of the Applicant to adhere to the requirements of their local electric service providers which may mean greater separation from SoCalGas meters.
- A clear and level workspace, as shown in Figure 18, is required. SoCalGas highly discourages the installation of any underground openings, such as but not limited to a utility box or vault, in the area designated as "Clear and Level Workspace," especially directly in front of the meter and riser, as it can prohibit future maintenance of our facilities.

**Note(s):**

1. Size and dimensions vary. Drawings are not to scale.
2. Meters and piping must be protected from vehicular damage, corrosive environments, and other safety related issues.
3. Meters cannot be placed under a carport roof, awning, enclosure, or any overhang larger than a standard eave, without prior approval of SoCalGas.
4. Meters are not to be installed behind solid walls, fences, or gates without SoCalGas access.









## 4.7 NON-RESIDENTIAL SINGLE METER CONFIGURATIONS

Generally, non-residential single meter configurations fall under the same general guidelines as residential meters except that the distances from riser to houseline can vary from 18" for a standard delivery pressure under 270 CFH load, up to 136" or more for a large industrial meter with elevated pressure. Additional equipment such as filters, separators, equipment protection (monitor) regulation, by-pass piping, valves or other components may be required to effectively serve the customer's needs. Although a 10'x3'x7' (WxDxH) area should serve most non-residential MSA applications, your SoCalGas planner will determine the most appropriate meter location and meter set assembly to serve your project. Elevated pressure (typically 5 psig) is available for qualifying non-residential applications upon documented request and receipt of the required plans and operating schedule for each of the natural gas equipment to be installed for your project (provide the schedule in hours/day, days/week, and weeks/year). See section 4.3 in this guidebook and visit the Submitting Your Project Plans Electronically section on [www.socalgas.com/new-construction](http://www.socalgas.com/new-construction).

## 4.8 NON-RESIDENTIAL MULTIPLE METER MANIFOLDS

Commercial meter manifolds are handled on a case-specific basis. Contact your SoCalGas planner for further guidance about spacing and condition requirements and please provide the operating schedule for each of the natural gas equipment to be installed for your project (provide the schedule in hours/day, days/week, and weeks/year).

## 4.9 MARKING HOUSELINES FOR MULTIPLE METER LOCATIONS

Per [CPUC Tariff Rule 21](#), Builders are responsible for identifying/marketing outlet houselines for SoCalGas connection. Markings must:

- Be permanent, prominent and legible at the service connection point.
- Identify the specific dwelling unit's street address, equipment location, or building, etc. to be served.
- SoCalGas will not install meters until houselines are accurately identified.

Per California Plumbing Code/Uniform Plumbing Code, it is a requirement to permanently display, through stamp or engraving, the exact unit # or street address each houseline feeds so SoCalGas can easily identify which manifold to address for emergency response, system testing, inspection and maintenance.

## 4.10 METER CABINETS, RECESSES, AND ENCLOSURES

Meter cabinets, recesses, and enclosures must comply with the general meter location requirements outlined in Section 4.4. Additionally, they must comply with the following guidelines:

- Be gas-tight at all interior seams and corners, including the seal around the houseline entrance into the recess/enclosure.
- All seals must be permanent to prevent natural gas from entering into the building or walls; materials such as silicone-based compounds can be used to make permanent seals.
- Enclosure doors should be a non-metallic material to not interfere with radio frequency (RF) signal transmission.
- Meter recess interiors can be the same material as the structure's exterior provided it is gas-tight; if additional sealing is required, it must be completed before MSA installation.
- Meter cabinets can be surface-mounted or partially recessed.
- Meter cabinets must be pre-approved by SoCalGas to be used.
- Only natural gas-related facilities are allowed within a natural gas meter recess/enclosure; foreign equipment (such as electrical conduits, water lines, telephone or TV cable, etc.) is prohibited; natural gas meter recesses/enclosures are not to be used as storage areas.
- Electric metering and any other potential sources of ignition must be a minimum of three radial feet from the regulator vent termination; no potential sources of ignition are permitted above a natural gas meter recess, cabinet or enclosure at any time.
- No doors, lattice work or covers of any type are permitted on the meter recess; the entire opening of the recess must be clear for installation and maintenance of the MSA.
- A minimum three-foot (four-foot preferred) clear and level working space must be maintained in front of the cabinet, enclosure or recess opening to a height of 78" above final grade.
- The wall area above the cabinet, enclosure or recess must be free of projections that might present a hazard to personnel servicing the MSA.
- The bottom floor of the recess or enclosure may be earth or paved and must be graded to prevent water from collecting inside the recess; if recess floor is paved, an opening 4" in diameter or 4" square sleeve must be provided around the riser; the required riser location is inside the recess and outside of the cabinet/enclosure.
- The recess walls and ceiling where they meet the exterior wall must be uncased and without open joints or other interruptions to the exterior wall finish.

**TABLE 2 - Meter Recess & Enclosure Dimensions and Riser and Houeline Spacing in Inches**

**Standard Delivery Pressure**

Meter Size	Riser to Back Wall		Riser to Houeline (Horiz.)	Min. Height	Min. Width	Depth	Ventilation Area Req.
	Recess	Encl					
	A	A	B	C	D	E	SQ. IN.
250	12	30	16	60	36	24	121
425	12	30	20	60	48	24	161
630	12	30	20	60	48	24	161
8C 15	12	42	26	60	48	36	245
15C175	12	42	32	60	60	36	307
3M175	12	42	46	60	72	36	368
5M175	18	54	46	60	72	48	499
7M175	18	54	53	60	72	48	499

**Above Standard Delivery Pressure**

Meter Size	Riser to Back Wall		Riser to Houeline (Horiz.)	Min. Height	Min. Width	Depth	Ventilation Area Req.
	Recess	Encl					
425	12	42	28	60	48	36	245
630	12	42	28	60	48	36	245
8C15	12	42	34	60	60	36	307
15C175	12	42	34	60	60	36	307
3M175	12	42	90	60	114	36	583
5M175	18	48	80	60	114	42	685
7M175	18	48	83	60	114	42	685
11M175	18	48	103	60	126	42	757

**4.10 METER CABINETS, RECESSES, AND ENCLOSURES (CONT)**

- The ceiling must have a slope from back to front, as shown in the Figures on the following pages, to facilitate escape of natural gas to the outside.
- Meter-stacking is limited to two-tier for enclosure and recess designs.
  - Minimum dimensions for single MSAs are shown in Table 2.
  - Minimum dimension requirements for multiple MSAs can be obtained through your SoCalGas representative.

**FIGURE 20 - Natural Gas Meter Cabinet Guidelines**

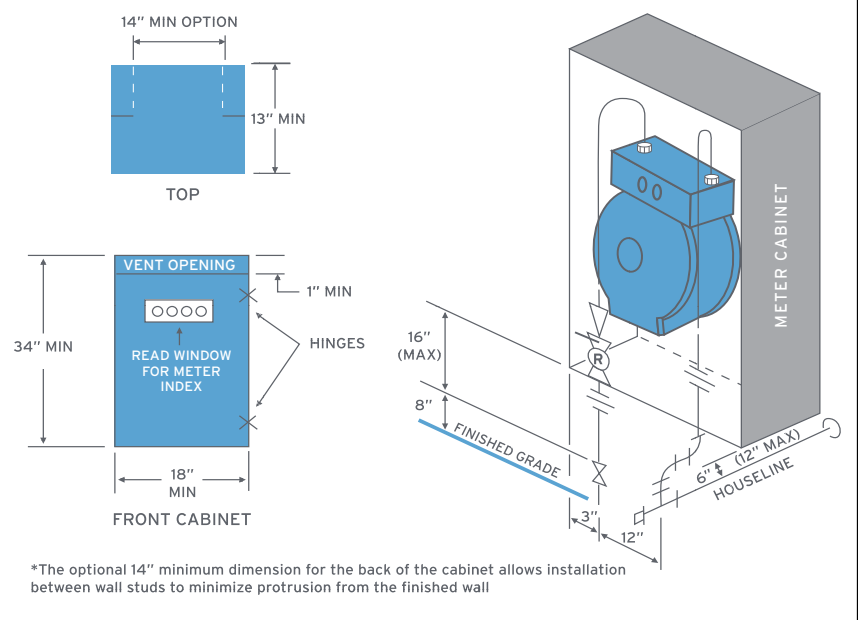

**FIGURE 21 - Single Natural Gas Meter Recess Guidelines**

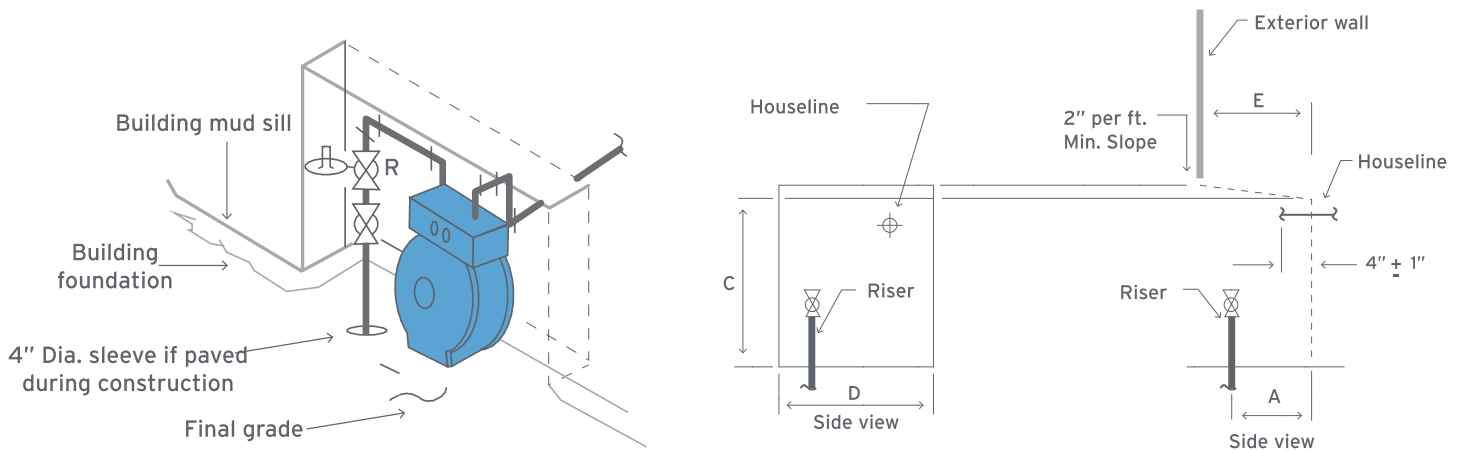

**FIGURE 22 - Natural Gas Meter Enclosure - Single Meter Surface Mount**

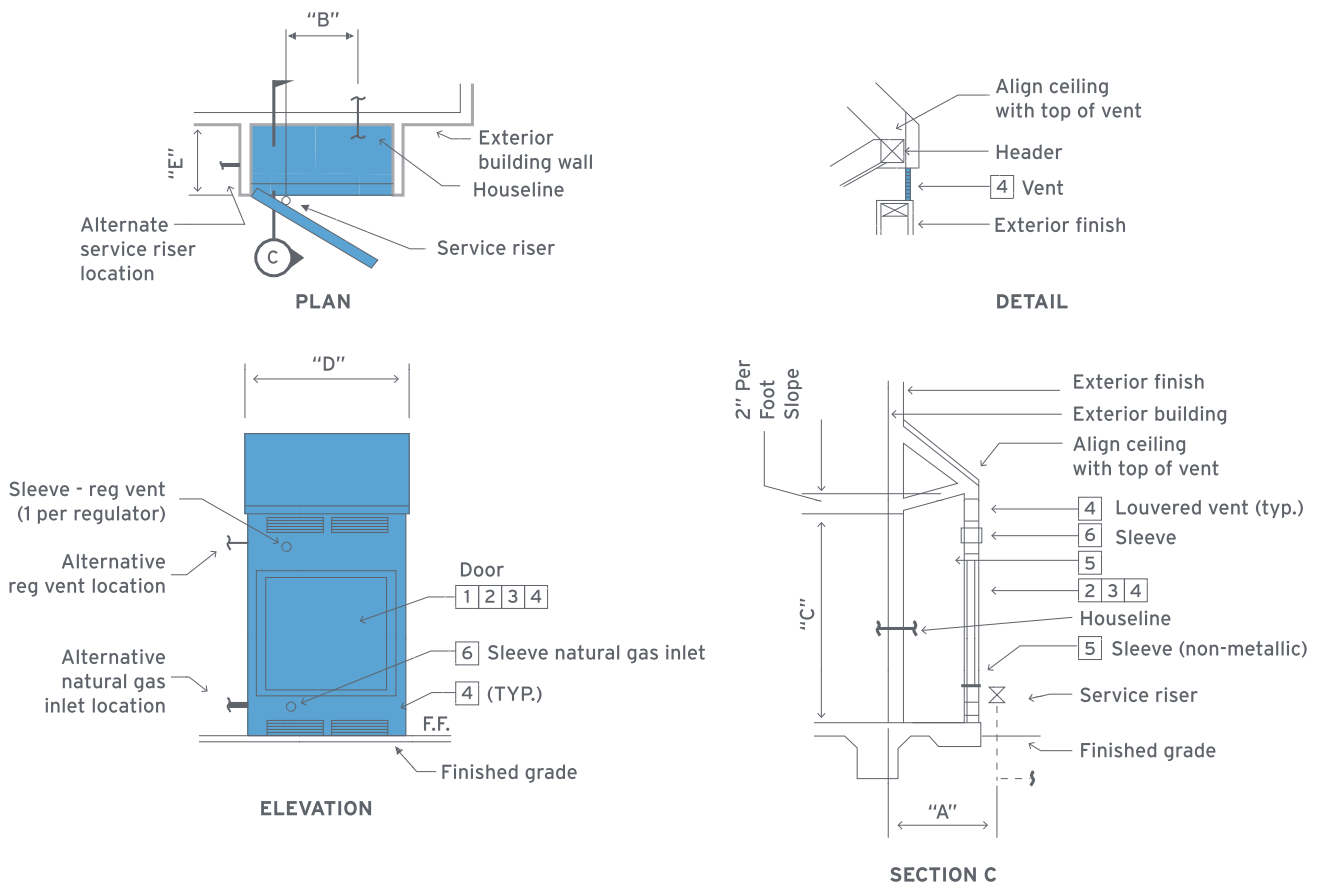

1. Enclosure doors may be full opening doors or they must meet the minimum size requirements established by SoCalGas. In all cases the maximum door is 48". Multiple doors are required for enclosures with door requirements exceeding 48" in width. All enclosure doors should be a non-metallic material to not interfere with radio frequency (RF) signal transmission.
2. Provide 1 pair butt hinges per door.
3. Access door with padlock latch.
4. Louver vent top and bottom each door and enclosure for required ventilation area shown in Table 2.
5. Provide sealed joints throughout interior of enclosure.
6. Sleeve size and location per SoCalGas instruction.

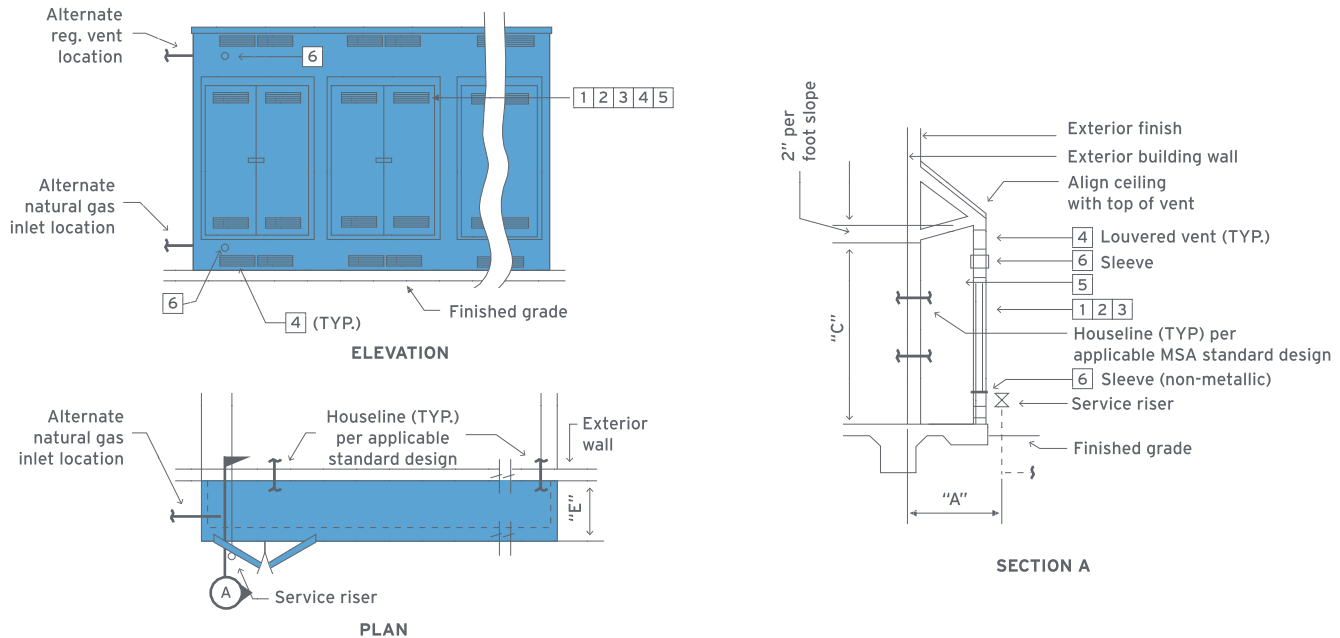
**FIGURE 23 - Natural Gas Meter Enclosure - Multiple Meter Surface Mount**

1. Enclosure doors may be full opening door or they must meet the minimum size requirements established by SoCalGas. In all cases the maximum door is 48". Multiple doors are required for enclosures with door requirements exceeding 48" in width. All enclosure doors should be a non-metallic material to not interfere with radio frequency (RF) signal transmission.
2. Provide 1 pair butt hinges per door.
3. Access door with padlock latch.
4. Louver vent top and bottom each door and enclosure for required ventilation area established by SoCalGas.
5. Provide sealed joints throughout interior of enclosure.
6. Sleeve size and location per SoCalGas instruction.

## 4.11 METER ROOM REQUIREMENTS

Meter rooms are defined as any closed space intended to contain natural gas meters. Builder/applicants must notify SoCalGas of their intent to create a natural gas meter room during their project's architectural design phase. Builders must submit both hard and electronic copies of the Engineering Design Package that substantiate conformance to all requirements outlined below. Additionally, this Package should include annotations and information that clearly identify compliance with all of the requirements listed in this section (and an index indicating where within the package each requirement is met). The Package must be approved (stamped and signed) by a current and active Professional Engineer licensed in the state of California and must also be approved by SoCalGas. If a natural gas meter room is not

constructed in accordance with drawings in the approved Engineering Design package, then SoCalGas reserves the right to postpone or suspend natural gas service until all requirements have been met. All meter rooms must comply with local codes and ordinances AND the following SoCalGas requirements:

### LOCATION

- Meter rooms with an above-grade location and at least one wall with an access door to the outside are strongly preferred.
- Meter rooms in basements, lower or elevated floor levels without direct outside access, are only considered when no other acceptable location is available, and if approved, may incur a Special Facility Ownership Charge (above obligated service). See [Rule 2](#) Section O for Special Facility details.

## ELECTRICAL

- All electrical equipment, lighting fixtures and switches shall meet NFPA Volume 70 requirements for Class I Division 2 Group D Locations.
- The natural gas meter room shall be provided with lighting that at a minimum meets the illumination requirements of the current edition of the California Building Code, and lighting shall be on an emergency back-up or an uninterruptable power supply (UPS).
- The natural gas meter room light switch shall be located outside of the room adjacent to the entry door with switch function identification.
- No electrical receptacles are permitted inside a natural gas meter room.
- Any electrical power requirements for SoCalGas measurement and/or communications equipment will be specified on a project specific basis by SoCalGas representatives as determined by the Measurement Regulation and Control Group in Gas Engineering.

## VENTILATION

- A mechanical ventilation system meeting the requirements of SoCalGas, California Building Code, California Mechanical Code, and all applicable local codes and ordinances shall be provided with a minimum capacity of at least six air exchanges per hour.
- The quantity and location of both the air inlet vents and the air exhaust fans shall be configured and located such that a complete or full exchange of air occurs within the room with each exchange.
- Knowledge of proper operation of the mechanical ventilation system shall occur at all times. This can be accomplished with:
  - Installation of a real-time continuous monitoring system with output to an on-site manned building control room (or to an off-site manned monitoring control center).
  - Installation of a back-up redundant exhaust fan system that activates upon failure of the primary fan system and sends an output alarm to a manned building control room (or to an off-site manned monitoring control center).
  - Installation of a locking cover over the isolation switch on the meter room air handlers when building code is requiring the developer to install the switch on the air handler itself or outside the meter room.

- The customers/builders must submit calculations and documentation that are approved (stamped and signed) by a California licensed professional engineer demonstrating that the ventilation system for the natural gas meter room satisfies all requirements within this document as well as all applicable codes, standards and ordinances.

## SECURITY/ACCESS

- Entry doors shall either be locked and provided with a lockbox located near the door containing the door key or they shall be secured with a double lock arrangement that allows access to the room by SoCalGas personnel as well as the appropriate on-site representative.
- In accordance with SoCalGas [Rule 25](#) (company's right of ingress to and egress from customer's premises) the property owner shall provide SoCalGas personnel with access to the natural gas meter room at all times including emergency response, meter reading, system testing, inspection and maintenance.

## SIGNAGE

- The access door(s) shall be identified with signs stating: "Gas Meter Room"; "Contains Flammable Gas" and "No Smoking Permitted".
- Additional "No Smoking" signs shall be posted on at least two interior walls of the natural gas meter room.

## CONSTRUCTION

- An outside shut-off valve shall be installed in the service line in a location accessible at all times for emergency shut down.
- Only natural gas-related facilities are allowed in the natural gas meter room. Other facilities, equipment or materials are prohibited (the only permitted exception may be a Fire Sprinkler System pursuant to NFPA-13). The room shall not be used for storage purposes at any time.
- All interior surfaces, joints and openings (penetrations) shall be sealed gas-tight to prevent natural gas from leaking into the building using a non-hardening silicone based compound. Doors that do not open to the outside shall seal gas-tight when closed.
- Floor drains are not permitted in a natural gas meter room.
- The natural gas meter room shall fully comply with the Use and Occupancy requirements for High-Hazard Group H-2 of the current applicable version of the California Building Code. All interior walls, ceilings, floors and doors shall be fire-rated for a minimum of



2 hours or as specified in the California Building Code for High-Hazard Group H-2 occupancies. Doors should be a non-metallic material to not interfere with radio frequency (RF) signal transmission.

- Natural gas meter room minimum dimensions will be specified by your SoCalGas representative to allow sufficient working space for construction and maintenance. The room height shall be a minimum of 7.5 feet and a maximum of 10 feet.
- Where three-tiered meter manifolds are installed, the appropriate on-site representative will provide work platforms specified by SoCalGas representatives.
- Any facilities/conduits/openings (penetrations) required for natural gas measurement and/or communications equipment will be specified on a project-specific basis by SoCalGas representatives as determined by the Measurement Regulation and Control Group of Gas Engineering.

### EQUIPMENT VENT PIPE

- The builder/applicant shall provide the number and size holes (penetrations) specified by your SoCalGas representative through the exterior wall to the outside to facilitate vent piping for natural gas regulating and control equipment and for purging during maintenance operations.
- For natural gas meter rooms without a wall with exterior access, the customer/builder shall install a separate steel vent pipe for each pressure regulating and control device. Additionally, the customer/builder shall install one steel vent pipe for purging natural gas during maintenance operations. Each steel vent pipe shall be at a location specified by SoCalGas and shall adhere to the following requirements (approved by the SoCalGas representative):
  - All vent piping shall be steel material and consist of standard welded or threaded pipe, pipe nipples and fittings that are approved for use by SoCalGas (CSST tubing is prohibited for use in vent piping).
  - Each vent pipe shall be the same size or larger as the size of each regulator vent.
  - Never downsize or decrease the size of vent piping.
  - To as great an extent as possible, minimize the length of all vent piping. The size of vent pipe shall be increased by one nominal pipe diameter for every 25 feet of vent pipe.
  - Always provide one vent pipe per regulator vent.
  - Never combine vent pipes into one pipe.
  - Each vent pipe shall be marked to identify the regulator or device to which it is connected.
  - All vent pipes shall be installed so as to avoid

liquid traps and shall be routed to the outside of the building to a "safe" location. They shall be terminated with a fitting designed to prevent the entry of insects, foreign material or moisture.

- A "safe" location for the terminus of vent piping shall avoid tripping or public hazards and be a minimum of 8 feet from any air intake, fresh air vent or building opening and a minimum of 3 feet from electric meters or any potential source of ignition.

### AUTOMATED METER DATA COLLECTOR UNIT (DCU) UTILITY CLOSET

- A separate DCU utility closet shall be constructed directly adjacent (with a common or shared wall) to the natural gas meter room.
- The DCU utility closet shall be constructed to the following requirements:
  - This closet shall be the same height as the natural gas meter room with a minimum width of six feet and a minimum depth of six feet.
  - All interior walls, ceilings, floors and doors shall be fire-rated for a minimum of two hours or as specified in the California Building Code for Group H Division 1 occupancies.
  - The DCU utility closet shall be provided with lighting that as a minimum meets the illumination requirements of the current edition of the California Building Code.
  - The DCU Utility Closet shall be supplied by a dedicated 15 Amp, 120V single phase circuit (two #10 AWG conductors). The dedicated circuit shall terminate to a fused disconnect switch inside the DCU Utility Closet. The fused disconnect switch shall be lockable with a 3 amp fuse installed. The dedicated circuit shall be tied to the ground system of the building.
  - The DCU utility closet shall include a quad outlet supplied by a dedicated circuit from the Building distribution panel.
  - One 1-1/2" conduit from the DCU utility closet to the outside of the building shall be provided which meets the following:
    - This conduit shall run the most direct path to the outside with a maximum distance of 100 feet.
    - Depending on site conditions, antenna(s) and/or related communication devices may be mounted to the building wall or to a roof parapet wall at a minimum height of 15 feet but no more than 30 feet above ground level. For this equipment the location where the conduit terminates to the outside of the building will be free from obstructions including the building itself.



- One 1-1/2" conduit from the DCU utility closet to the natural gas meter room shall be provided (this conduit shall be sealed after installation of SoCalGas' conductors).
- One 1-1/2" conduit from the DCU utility closet to the building telecommunications room shall be provided.
- The access door to the DCU utility closet shall be identified with a sign identifying: "SoCalGas Communication Closet".
- The access door shall also include appropriate radio frequency (RF) signage that conforms to IEEE ANSI Standard C95.2 and FCC OET 65, this sign will be provided by SoCalGas (see Figure 24 below):

**FIGURE 24 - Conforming RF Signage Sample**



**FIGURE 25 - Natural Gas Meter Service Delivery Point**

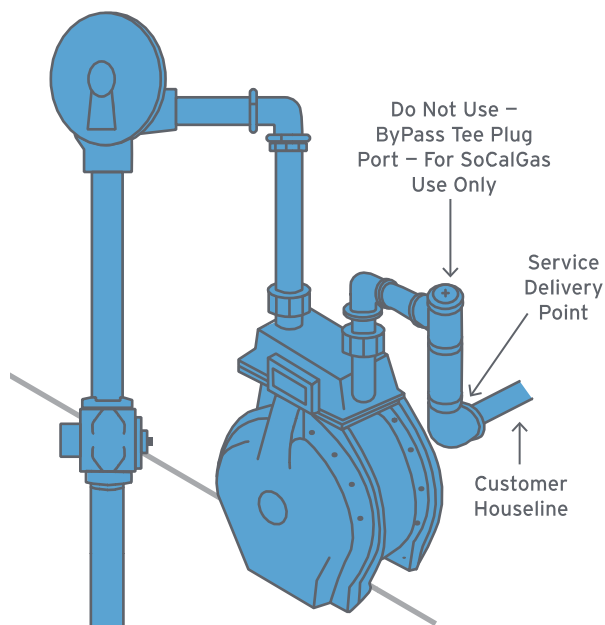

## SECTION 5 APPLICANT-OWNED PIPING (HOUSELINE)

- All **builder/applicant-installed** piping shall be steel and constructed in accordance with NFPA 54 and all local codes and ordinances.
- Houeline piping must be adequately supported to minimize structural load on the MSA.
- It shall not interfere in any way with the installation, operation and maintenance of SoCalGas® equipment.
- When flexible corrugated stainless steel tubing (CSST) is used, it shall be connected to the MSA outlet with standard threaded pipe fittings and steel pipe or pipe nipples properly supported and approved by SoCalGas.

### 5.1 SERVICE DELIVERY POINT

The natural gas service delivery point is where SoCalGas' facilities connect to the Applicant-owned natural gas piping or houeline.

This is applicable for most residential and small commercial meter set assemblies.

For larger commercial and industrial installations, the service delivery point is located downstream of or after all SoCalGas natural gas facilities and where customer piping commences. Typically, it's where the Applicant's piping is connected to SoCalGas' piping downstream of the by-pass valve assembly. Please see Figure 25.

#### IMPORTANT NOTE

- Use of the bypass tee outlet plug port is strictly prohibited. The plug port is used by SoCalGas to perform MSA service and maintenance.
- Builder/applicants are prohibited from connecting to or installing fittings on the SoCalGas-owned MSA (upstream of or before the service delivery point).
- If necessary, Builder/applicants must install bracing for houeline support.
- A flexible houeline connection to the service delivery point is strictly prohibited (except for Mobile Home applications).

## SECTION 6 ADVANCED METER LOCATION REQUIREMENTS

As part of the SoCalGas® Advanced Meter program, all newly-installed SoCalGas meters will have the ability to be read and monitored remotely. To do so may require SoCalGas to install a remote module to ensure proper radio frequency transmissions. This necessary equipment may be installed on nearby natural gas facilities, interior walls or an outside location.

## SECTION 7 LOCATION OF APPLICANT- OWNED VALVES, STEP-DOWN REGULATORS, AND AUTOMATIC SHUT-OFF DEVICES

Builder/applicants are responsible for maintaining customer-installed-and-owned natural gas piping (yard or houselines), valves, regulators, shut-off devices, or any other piping component on the premise affixed to the natural gas system.

Builder/applicant-installed-and-owned equipment must not interfere or obstruct the operation or maintenance of SoCalGas' piping, regulation, or meter equipment. If Builder equipment is found to obstruct SoCalGas® natural gas facilities, natural gas service may be discontinued until equipment no longer impedes SoCalGas equipment operation.

For new construction,

- For Non-Residential 2 PSI, 5 PSI and above systems, the regulators must be reached safely no more than approximately 48" off the working surface (view Figure 26). Attic installations are unacceptable.
- For 2 PSI and 5 PSI Residential, builder/applicant shall install step-down regulator(s) in a safe and readily accessible location that has adequate room to work (two feet clearance front and sides) and must be reached safely between one and five feet above ground level (view Figure 27 or [Residential New Construction 2 PSIG Program](#)). Regulators are not allowed above parking spaces, above lanes of traffic (underground parking structures) or in attics.
- Due to safety concerns, SoCalGas employees cannot perform initial meter and natural gas turn-on if there is natural gas-controlling equipment that requires use of engineered lifts or ladders to access.

**FIGURE 26 - Requirements for New Step-Down Manifolds for Non-Residential 2 PSIG, 5 PSIG and Above Systems**

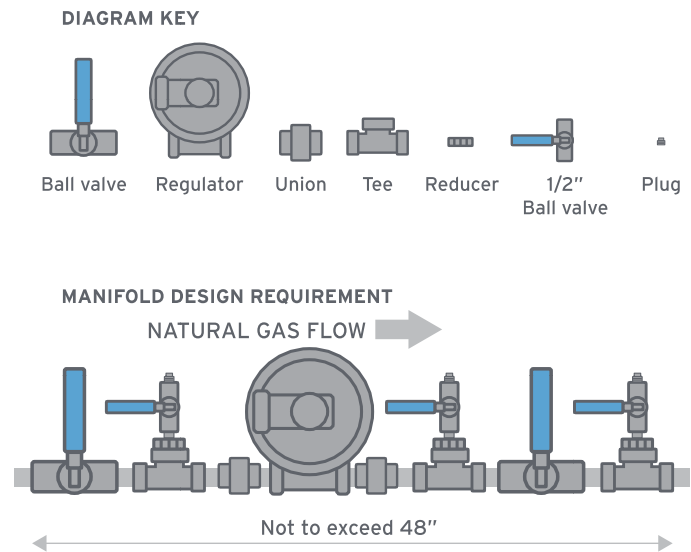

**FIGURE 27 - Requirements for New Step-Down Manifolds for Residential 2 PSIG and 5 PSIG Systems**

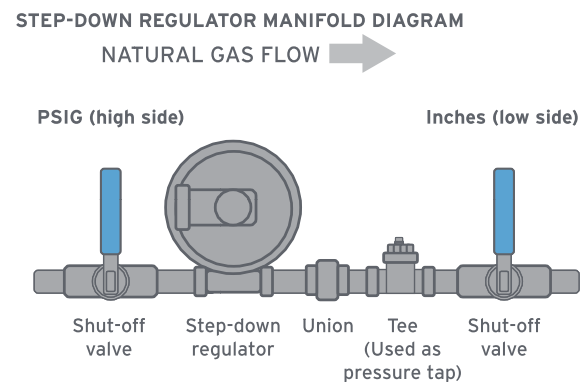

## SECTION 8

### GROUNDING NATURAL GAS PIPE

Builder/applicants must ensure that houseline natural gas pipe is electrically bonded and grounded. They must comply with local codes and ordinances, regulations, and standards on electric bonding and grounding.

Builder/applicants must **not** allow natural gas pipe to be used as described below.

- Do **not** allow houseline natural gas pipe to be electrically bonded to SoCalGas natural gas service piping, natural gas risers, or meter facilities. Also, do **not** allow natural gas pipe to be electrically bonded to the inside of meter enclosures, cabinets, or meter rooms.
- Do **not** use SoCalGas' natural gas service piping, risers or meter facilities for electric grounding or in a manner that allows the natural gas piping or other natural gas facilities to become current-carrying conductors.

## SECTION 9

### NATURAL GAS FLOW PROTECTIVE EQUIPMENT

SoCalGas' natural gas metering equipment can be adversely affected when a customer's equipment causes:

- Pulsations in the natural gas flow
- Sudden changes in flow rate
- A backflow condition

Builder/applicants must install, at their expense, any equipment necessary to mitigate or eliminate these detrimental effects. SoCalGas will review and approve installations before re-initiating natural gas service. Builder/applicants must add any necessary protective equipment when their operations change and those changes could result in adverse metering conditions.

SoCalGas may terminate service and refuse to restore that service if the identified issues are not resolved promptly or the builder/applicant disregards SoCalGas notifications and continues to operate without proper protective equipment.

Builder/applicants are responsible for damages made to SoCalGas equipment due to failure to install proper protective equipment.

## APPENDIX A

### CHECKLIST FOR APPLICANTS WITH A REQUEST FOR A NATURAL GAS SERVICE LINE EXTENSION OR WITH A REQUEST TO UPSIZE AN EXISTING NON-RESIDENTIAL METER

#### Before Being Assigned to a SoCalGas Planning Representative

- Secure appropriate permits for construction
- Read the Natural Gas Service Guidebook on [www.socalgas.com/new-construction](http://www.socalgas.com/new-construction)
- Determine if you would like to request elevated pressure (Note: those with residential projects can read the Residential New Construction 2 PSIG Program section on [www.socalgas.com/new-construction](http://www.socalgas.com/new-construction) for more details)
- If your project is an electric/propane conversion, determine the appliances/equipment that are convertible to natural gas (Note: if you need your appliances inspected to make this determination, schedule through SoCalGas Customer Contact Center)
- Submit a Request for New Natural Gas Service on [www.socalgas.com/new-construction](http://www.socalgas.com/new-construction) and include accurate natural gas appliance/equipment information in BTUs
- Read the Submitting Your Project Plans Electronically section on [www.socalgas.com/new-construction](http://www.socalgas.com/new-construction) to determine the plans and documents you will be required to provide

#### Once Assigned to a SoCalGas Planning Representative

- Submit the appropriate plans as outlined on the Submitting Your Project Plans Electronically section on [www.socalgas.com/new-construction](http://www.socalgas.com/new-construction)
- If you would like a consultant or agent to request and receive information regarding your SoCalGas project on your behalf, request and complete a form titled, [Authorization to Obtain Confidential Customer Information and Act on Customer's Behalf](#)
- If the trenching, installation of natural gas pipe, and/or design of natural gas pipe will be performed by a contractor or sub-contractor of your choice, ensure the contractor/sub-contractor meets the qualifications outlined in the Natural Gas Service Guidebook on [www.socalgas.com/new-construction](http://www.socalgas.com/new-construction)
- Log into the New Construction Status Tracker on [www.socalgas.com/ncst](http://www.socalgas.com/ncst) to follow the status of your online application for new natural gas service for both residential and nonresidential projects once you have received your confirmation email message that contains your Project Number and your unique five-digit access code

#### Once Contract is Received

- Read the Understanding Your Line Extension Contract section on [www.socalgas.com/new-construction](http://www.socalgas.com/new-construction)
- Read, sign, and return contract and any corresponding documents included with contract
- Make payment if money is owed (Note: payment instructions are outlined on cover sheet of contract)

#### Before or During the Installation of Your Natural Gas Facilities

- Establish a billing account with SoCalGas prior to requesting meter set and turn-on by visiting [www.socalgas.com/schedule-service](http://www.socalgas.com/schedule-service) or calling 877-238-0092 (Residential)/800-427-2000 (Non-residential)
- Work with your inspecting agency to obtain a houseline approval

#### To Set and Turn-on Meter After Receiving Houseline Approval

- Contact the SoCalGas Meter Set Desk at 800-228-7377 or [setdesk@socalgas.com](mailto:setdesk@socalgas.com)

## APPENDIX B

### CHECKLIST FOR APPLICANTS WITH A REQUEST FOR A RELOCATION/ALTERATION OR ABANDONMENT OF EXISTING NATURAL GAS FACILITIES, OR WITH A REQUEST TO UPSIZE AN EXISTING RESIDENTIAL METER

#### Before Being Assigned to a SoCalGas Planning Representative

- Secure appropriate permit for construction or demolition
- Read the Natural Gas Service Guidebook on [www.socalgas.com/new-construction](http://www.socalgas.com/new-construction)
- If applicable, determine if you would like elevated pressure (Note: those with residential projects can read the Residential New Construction 2 PSIG Program section on [www.socalgas.com/new-construction](http://www.socalgas.com/new-construction) for more details)
- Submit a request for relocation/alteration/abandonment of existing facilities on [www.socalgas.com/new-construction](http://www.socalgas.com/new-construction)
- Read the Submitting Your Project Plans Electronically section on [www.socalgas.com/new-construction](http://www.socalgas.com/new-construction) to determine the plans and documents you will be required to provide

#### Once Assigned to a SoCalGas Planning Representative

- Submit the appropriate plans as outlined on the Submitting Your Project Plans Electronically section on [www.socalgas.com/new-construction](http://www.socalgas.com/new-construction)
- If you would like a consultant or agent to request and receive information regarding your SoCalGas project on your behalf, request and complete a form titled, [Authorization to Obtain Confidential Customer Information and Act on Customer's Behalf](#)
- If trenching will be performed by a contractor or sub-contractor of your choice, ensure the contractor/sub-contractor meets the qualifications outlined in the Natural Gas Service Guidebook on [www.socalgas.com/new-construction](http://www.socalgas.com/new-construction)

#### Once Contract is Received, If Applicable

- Read, sign, and return contract and any corresponding documents included with contract
- Make payment (Note: payment instructions are outlined on invoice)

#### Before or During the Installation of Your Natural Gas Facilities

- If applicable, work with your inspecting agency to obtain a houeline approval

#### To Set and Turn-on Meter After Receiving Houeline Approval, If Applicable

- Contact the SoCalGas Meter Set Desk at 800-228-7377 or [setdesk@socalgas.com](mailto:setdesk@socalgas.com)



| [socalgas.com](http://socalgas.com) |

1-800-427-2000 |

