

CLICK ANYWHERE on THIS PAGE to RETURN TO WATER PUMP & TANK I&O & REPAIR MANUALS at InspectApedia.com

SEARS

**OWNER'S
MANUAL**

MODEL NO.
390.2508

CAUTION:
Read and Follow
All Safety Rules and
Operating Instructions
Before First Use of
This Product.

Save This Manual For
Future Reference.

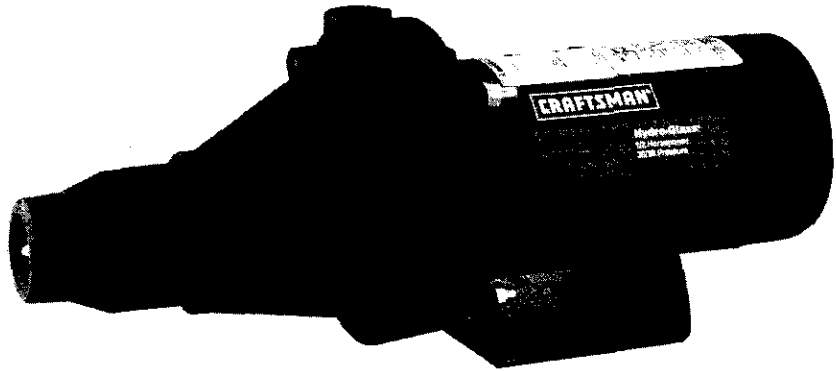

CRAFTSMAN® HYDROGLASS® SHALLOW WELL JET PUMP

- Safety Instructions
- Installation
- Operation
- Troubleshooting
- Repair Parts

Sears, Roebuck and Co., Hoffman Estates, IL 60179 U.S.A.

CONTENTS

Warranty	2
Pump Performance	3
Major Components	3
Piping	3-4
Installation	4
Electrical	5
Operation/Maintenance	6-9
Helpful Hints	9
Troubleshooting Guide	10
Repair Parts	11

INTRODUCTION

Please read our instructions before installing and using your pump. This will help you obtain the full benefits of the quality and convenience built into this equipment. It will also help you avoid any needless service expense resulting from causes beyond our control which are not covered by our warranty.

FULL ONE YEAR WARRANTY ON CRAFTSMAN® WELL PUMPS

For one year from the date of purchase, Sears will repair or replace this pump, free of charge, if defective in material or workmanship.

LIMITED WARRANTY ON CRAFTSMAN® PROFESSIONAL HYDROGLASS® WELL PUMPS

After one year and through three years from the date of purchase, Sears will furnish, free of charge, a replacement part for any defective part. You pay for labor.

LIMITED WARRANTY ON CRAFTSMAN® HYDROGLASS® WELL PUMP

After one year and through two years from the date of purchase, Sears will furnish, free of charge, a replacement part for any defective part. You pay for labor.

This warranty does not cover repairs or replacement parts necessary because of abuse or negligence including failure to install, adjust and operate this pump according to the instructions in the owner's manual.

LIMITATION OF LIABILITY

SEARS WILL NOT BE LIABLE FOR LOSS OR DAMAGE TO PROPERTY OR ANY INCIDENTAL OR CONSEQUENTIAL LOSS OR EXPENSE FROM PROPERTY DAMAGE DUE DIRECTLY OR INDIRECTLY FROM THE USE OF THIS PRODUCT.

Some states do not allow the exclusion or limitation of incidental or consequential damages, so the above limitation or exclusion may not apply to you.

WARRANTY SERVICE IS AVAILABLE BY SIMPLY CONTACTING THE NEAREST SEARS SERVICE CENTER/DEPARTMENT IN THE UNITED STATES.

This warranty applies only while the product is in use in the United States.

This warranty gives you specific legal rights, and you may also have other rights which vary from state to state.

Sears, Roebuck and Co., Dept. 817 WA, Hoffman Estates, IL 60179

RULES FOR SAFE INSTALLATION AND OPERATION

1. Read the Owners Manual and Rules for Installation and Safe Operation carefully. Failure to follow these Rules and Instructions could cause serious bodily injury, and/or property damage.
2. Check your local electrical wiring codes before installation. If your local codes are not followed, your pump will not work to its full rated capacity and could present a fire hazard. If in doubt, contact your local power company.
3. **BE SURE** your pump installation meets all local plumbing, pump and well codes.
4. While installing your pump, always keep the well covered to prevent leaves and foreign matter from falling into the well, contaminating the water and/or causing possible serious damage to the mechanical operation of the pump.
5. Always test the water from well for purity before using. Check with local health department for testing procedure.
6. Before installing or servicing your pump, **BE SURE** pump power source is disconnected.
7. **BE SURE** your pump electrical circuit is properly grounded.
8. Complete pump and piping system **MUST** be protected against below freezing temperature. Allowing the pump or piping to freeze could cause severe damage and voids the Warranty.
9. **BE SURE** the line voltage and frequency of the electrical current supply agree with the motor wiring as shown on motor nameplate.
10. The correct fusing and wiring sizing is essential to proper motor operation. Recommended fusing and wire size data is in the manual (Page 5).
11. Pump water only with this pump.
12. Periodically inspect pump and system components.

▲ CAUTION Motor normally operates at high temperature and will be too hot to touch. It is protected from heat damage during operation by an automatic internal cutoff switch. Before handling pump or motor, stop motor and allow it to cool for 20 minutes.

GENERAL INFORMATION

Table I: Pump Performance Chart (In Gallons Per Minute)

Pump Model	Description	Suction Size	Discharge Size	Discharge Pressure P.S.I.	Pumping Depth in Feet			
					5'	10'	15'	20'
390.2508	1/2 HP Standard S.W. Jet	1-1/4"	3/4"	40	7.3	6.2	5.2	4.2

MAJOR COMPONENTS AND WHAT THEY DO

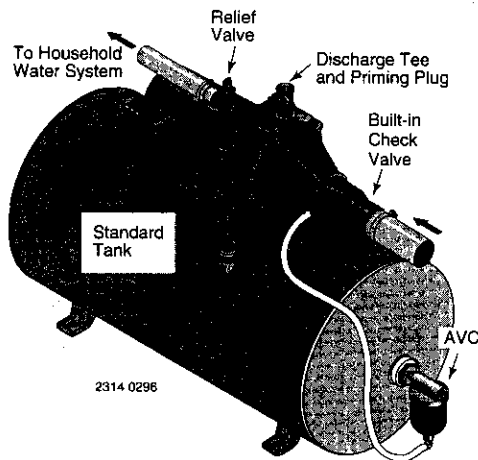

Figure 1

Impeller and Jet

Impeller turns with motor shaft, causing the water to fly out from its rim by centrifugal force. Impeller rotation creates a vacuum which pulls in more water. Part of the water is diverted back to the jet where it passes through the nozzle and venturi. This creates more vacuum to draw in more water.

In shallow wells (less than 20 feet deep), the vacuum created at the pump is enough to pull water to the pump. Therefore, for shallow well use the jet is built into the pump.

Air Volume Control

The air volume control (AVC) maintains the cushion of air in Standard tanks.

Pressure Switch

The pressure switch provides automatic control.

MODEL NO.	PUMP STARTS AT	PUMP STOPS AT
390.2508	30 Pounds	50 Pounds

Check Valve or Foot Valve

This pump is equipped with a built-in check valve. Install a foot valve in the well on dug or cased wells. See Figure 3, Page 4.

Tank

The tank serves two functions. It provides a reservoir of water, some of which can be drawn through the house fixture before the pump must start. It maintains a cushion of air under pressure.

Two types of tanks are available: Captive Air® and Standard. No air volume control is needed with Captive® Air Tanks.

PIPING

Piping in the Well

A Shallow well jet pump can be installed on a dug well, drilled well or with a driven point. In a dug or ased well, a foot valve and strainer should be installed for easy priming. It should be five to ten feet below the lowest level to which the water will drop while pump is operating (pumping water level).

The strainer should not be too close to the bottom or sediment may clog it. Before installing the foot valve, check to see that it works freely.

When installed on a driven pont well, your Shallow Well Jet Pump should have a check valve installed as shown in Figure 2.

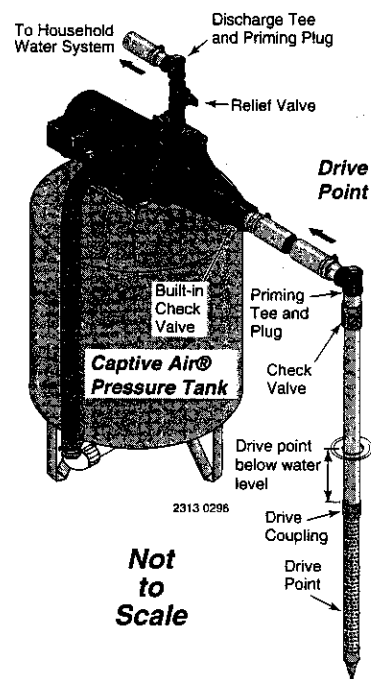

Figure 2

For a pump at sea level, be sure the vertical distance (lift) from the pumping water level to the pump is not over 20 feet if the pump is over the well. This will be less if the pump is offset from the well.

The maximum lift of any pump decreases at the rate of about 1' less lift for every 1,000 feet elevation above sea level. For example, if your are at 5,000 feet elevation such as in Denver, Colorado, you would loose five feet of lift. The maximum depth from which oyou could pump water would therefore be 15 feet.

PIPING

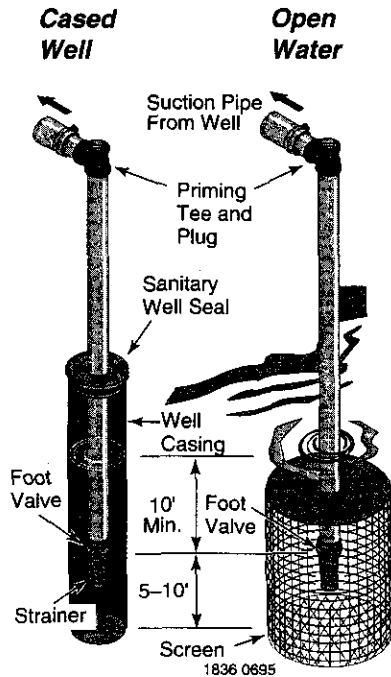

Figure 3

Horizontal Piping From Well To Pump

When the pump is offset more than 25 feet from the well, horizontal piping should be increased in size to reduce friction losses. In no case should the offset piping be smaller than the suction tapping of the pump.

Horizontal Offset Piping Sizes for Shallow Well Jets

1-1/4"	1-1/2"	2"
Up to 25 Ft.	25 to 50 Ft.	50 to 200 Ft.

Discharge Pipe Sizes

When the pump is set at a distance from the house or point of water use, the discharge pipe size should be increased to reduce pressure losses caused by friction.

1"	1-1/4"	1-1/2"
Up to 25 Ft.	25 to 100 Ft.	100 to 600 Ft.

INSTALLATION

If horizontal suction pipe is more than 25' long, install a priming plug at well head to allow filling of pipe.

SEARS jet pumps should be used with Captive Air® Tanks (see Figure 2, Page 3). For mounting pump to tank, purchase tank fittings Kit No. 2788.

SEARS Captive Air® Tanks are pre-charged with air at the factory. Check the tank Owner's Manual to find if air charge needs adjustment. Pump model 390.2508 requires 30 pounds for proper operation.

The Jet pump can also be mounted on standard horizontal tanks. A mounting kit with an AVC is furnished with tank (Figure 1, Page 3). Instructions are also included.

The installation, operation and care of your Hydroglass® pump is very similar to cast iron pumps. We ask, however, that you keep the following points in mind.

IMPORTANT: Use teflon tape supplied with the pump for making all threaded connections to the pump itself. Do not use pipe joint compounds on the pump!

1. Wrap one and one-half to two layers of Teflon tape on all male threads being attached to pump. This will insure leakproof connections. Do not overtighten threaded fittings in the plastic pump. If leaks do occur, remove the fitting, **clean off** the old Teflon tape, rewrap with one and one-half to two layers of new tape and remake the connection.
2. Be sure to support all piping connected to your Shallow Well Jet Pump.
3. To connect AVC to the pump, remove the 1/8" pipe plug (Key No. 13, Page 11) from the jet portion of the pump body near the suction tapping. Insert a 1/8" fitting into this tapping. Cut tubing to length and assemble the two fittings on the air volume control and pump body.

ELECTRICAL

⚠ Disconnect power before working on pump, motor, pressure switch, or wiring.

Motor Switch Settings

If the motor can operate at either 115 or 230 volts, it is set at the factory to 230 volts. Do not change motor voltage setting if line voltage is 230 volts, or if you have a single voltage motor.

NOTICE: Never wire a 115 volt motor to a 230 volt line.

Remove Motor End Cover

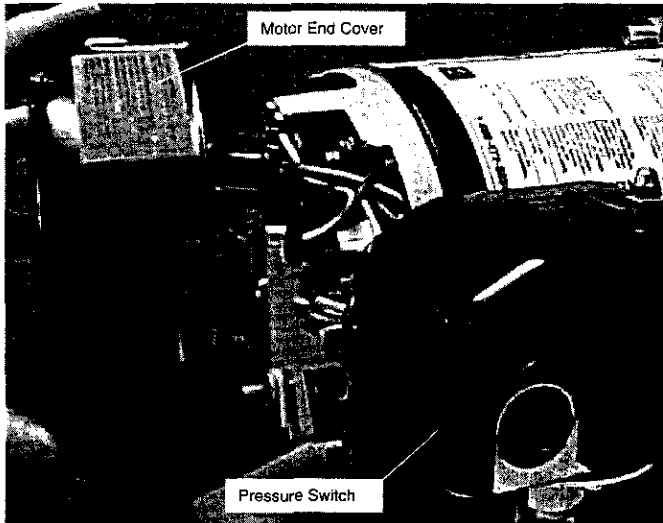

Figure 4 – Removing Motor End Cover

You will need to remove the motor end cover to change the voltage setting. The illustration above also shows the pressure switch. If the power supply connection still needs to be made, the pressure switch cover will need to be removed.

Your motor terminal board (located under the motor end cover) should look like the one at right.

Dial Type Voltage Selector

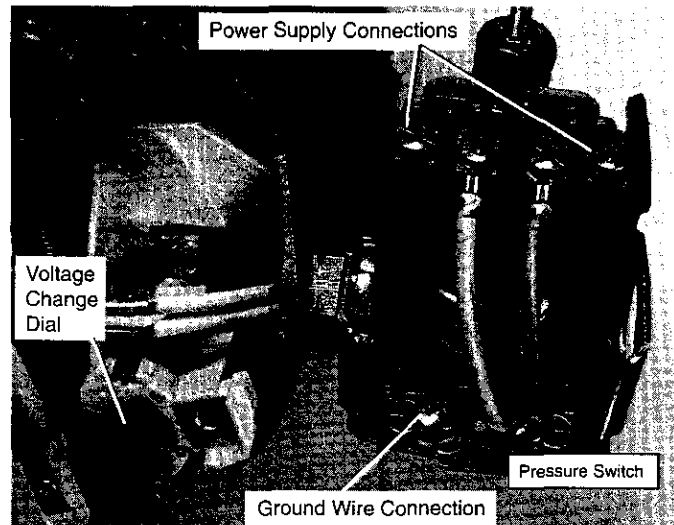

Figure 5 – Voltage Set To 230 Volts, Dial Type

To change to 115 volts:

1. Make sure power is off.
2. Turn the dial counter-clockwise until 115 shows in the dial window.
3. Reinstall the Motor end cover
4. Go to Wiring Connections, Page 6.

⚠ WARNING Hazardous voltage. Can shock, burn, or kill. Connect ground wire before connecting power supply wires. Use the wire size (including the ground wire) specified in the wiring chart. If possible, connect the pump to a separate branch circuit with no other appliances on it.

⚠ WARNING Explosion hazard. Do not ground to a gas supply line.

ELECTRICAL

WIRING CONNECTIONS

⚠ WARNING Fire hazard. Incorrect voltage can cause a fire or seriously damage the motor and voids the warranty. The supply voltage must be within $\pm 10\%$ of the motor nameplate voltage.

NOTICE: Dual-voltage motors are factory wired for 230 volts. If necessary, reconnect the motor for 115 volts, as shown. Do not alter the wiring in single voltage motors.

Install, ground, wire, and maintain your pump in compliance with the National Electrical Code (NEC) or the Canadian Electrical Code (CEC), as applicable, and with all local codes and ordinances that apply. Consult your local building inspector for code information.

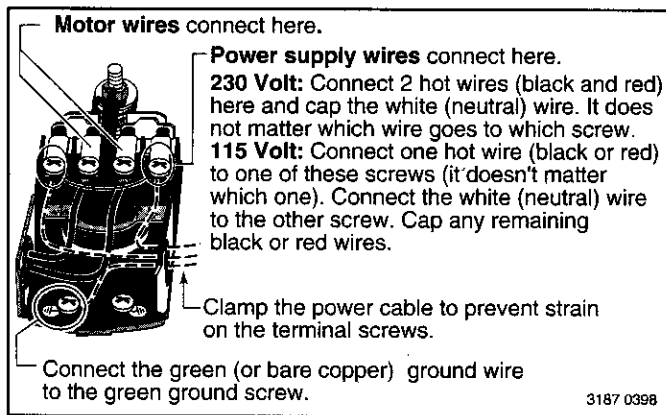

Figure 6 – Pressure switch wiring

Connection Procedure:

1. Connect the ground wire first as shown in Figure 6. The ground wire must be a solid copper wire at least as large as the power supply wires.
2. There must be a solid metal connection between the pressure switch and the motor for motor grounding protection. If the pressure switch is not connected to the motor, connect the green ground screw in the switch to the green ground screw under the motor end cover. Use a solid copper wire at least as large as the power supply wires.
3. Connect the ground wire to a grounded lead in a service panel, to a metal underground water pipe, to a metal well casing at least ten feet (3M) long, or to a ground electrode provided by the power company or the hydro authority.
4. Connect the power supply wires to the pressure switch as shown in Figure 6.
5. Reinstall the pressure switch cover.

TABLE II: WIRING CHART – Recommended Fusing and Wiring Data

Motor Horsepower	Volts	Max. Load Amperes	Branch* Fuse Rating Amps	Distance in Feet From Motor to Meter					
				0' to 50'	51' to 100'	101' to 200'	201' to 300'	201' to 400'	401' to 500'
				Wire Size					
1/2	115/230	10.4/5.2	15/15	14/14	14/14	10/14	8/14	6/14	6/12

* Time delayed fuses are recommended instead of regular fuses in any motor circuit.

OPERATION

Priming the Pump

NOTE: To properly prime the pump, install a pipe tee in the discharge piping, similar to that shown in Figures 1 and 2 on Page 3.

▲ CAUTION **Never run pump dry.** Running pump without water may cause pump to overheat, damaging seal and possibly causing burns to persons handling pump. Fill pump with water before starting.

▲ WARNING **Explosion Hazard.** Never run pump against closed discharge. To do so can boil water inside pump, causing hazardous pressure in unit, risk of explosion and possibly scalding persons handling pump.

To prevent damage to internal parts, do not start motor until pump has been filled with water.

To prime pump:

1. Remove priming plug (Figure 1, Page 3).
2. Fill pump with water.
3. Replace priming plug, using Teflon tape on plug threads; tighten plug.
4. Start the pump. Water should be pumped in 1-2 minutes. If not, repeat steps 1, 2 and 3.

On shallow depths to water (ten feet or less), the pump will more than likely prime the first time after following the outlined procedure.

From ten to 20 foot depths, it is very likely you will have to shut the pump off and reprime per the outlined procedure several times.

5. If, after priming pump several times, no water is pumped, check the following:
 - A. Be sure suction pipe is in the water.
 - B. Be sure suction pipe has no leaks.
 - C. Be sure the pump is not trying to lift water too high. (See "Piping in the Well," Page 4).
6. As long as foot valve and check valve function correctly and suction pipe does not develop leaks, pump should not need repriming in normal service.

MAINTAINING YOUR PUMP

Lubrication

It is not necessary to lubricate the pump or its motor. The motor bearings are lubricated for life. The mechanical shaft seal in the pump is water lubricated and self-adjusting.

Draining for Winter

When the pump is to be disconnected from service or is in danger of freezing, it must be drained. To drain it, turn off power and relieve all pressure on the system. Remove pressure switch tubing from the side of the pump housing. Remove the priming plug to vent the pump. Drain the pressure tank; drain all piping to a point below the freeze line.

To drain an air volume control (AVC), remove the tubing from it and turn the AVC upside down. This will permit any water in the AVC to drain into tank.

Disassembly and Assembly of Pump

▲ WARNING **Risk of electrical shock.** Be sure unit is grounded and power disconnected before attempting any work on pump or motor.

Your SEARS pump is designed for ease in servicing. Should repair or replacement of the motor or seal be needed, the pump and piping do not need to be disconnected or disturbed.

1. Disassemble pump as follows:

- A. Disconnect power.
- B. Remove pressure switch tube from pump body and allow pump to drain.
- C. Remove four hexnuts and lockwashers (Key Nos. 24 and 23, Page 12) which hold the pump body to the motor.
- D. Remove motor, seal plate, impeller, rubber pad and diffuser (Key Nos. 1, 3, 7, 8 and 9, Page 12) as a unit. You may have to pry gently with two screwdrivers between the motor flange and the pump body to separate pump and motor.

2. Reassembly of pump:

- A. Install O-Ring gasket on seal plate (Key Nos. 5 and 3, Page 12).
- B. Pick up a **small** amount of petroleum jelly on one finger and spread evenly over seal plate and venturi O-Ring gasket for lubrication during reassembly. **Be careful** not to nick or tear O-Ring.
- C. Replace motor onto pump body; be sure rubber pad (Key No. 8, Page 12) stays in place on top of diffuser. Remount base on lower studs. Tighten four hexnuts and lockwashers snugly (35-45 inch-lbs. torque). **Do not overtighten.**
- D. Replace pressure switch tubing and motor wiring.
- E. Prime pump according to instructions above.
- F. Check for leaks.

Removing Motor for Service and Replacing Shaft Seal

If it is necessary to separate motor and seal plate, always replace the shaft seal. We suggest you purchase this item, U109-6A, and have it on hand for future use.

NOTICE: The seal consists of two parts, a rotating member and a ceramic seat. The surfaces of the seal are easily damaged. Read instructions carefully.

Remove motor as follows:

1. Disassemble pump per instructions above.
2. Remove diffuser and impeller as follows (Key Nos. 9 and 7, Page 12).
 - A. Remove screws holding diffuser.
 - B. Loosen two screws and remove motor canopy from motor (Key No. 1, Page 12).
 - C. Place 7/16" open end wrench on motor shaft flat.
 - D. Turn impeller counterclockwise when facing it.

OPERATION

- Remove seal plate from motor by inserting two screwdrivers between the seal plate and the motor flange. Pry seal plate off motor flange. This will force rotating portion of seal off shaft.

NOTE: Be sure you do not scratch shaft!

See Figures 7 & 8.

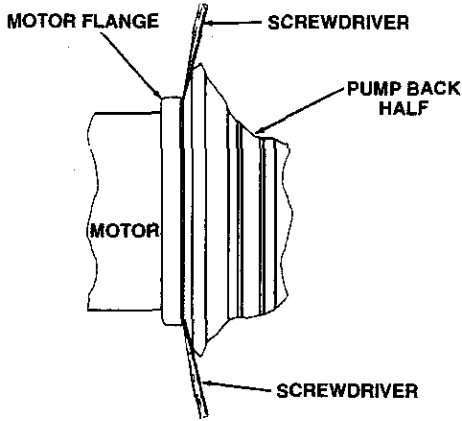

Figure 7

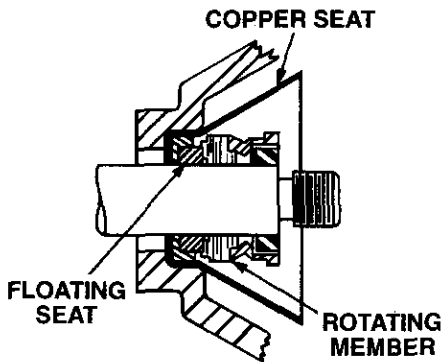

Figure 8

- Place seal plate face down on flat surface and tap out ceramic seat.

NOTICE: Do not force out copper insert. If it has moved, leakage will occur. See section on installing copper insert on Page 9.

- Clean seal cavity.
- Install new seal.
 - Clean polished surface of ceramic seat with clean cloth.
 - Wet outer edge of cup seal with petroleum jelly or detergent solution.
 - With finger pressure, press firmly and squarely into cavity. Polished face of seat faces inside of pump. If seat will not locate properly, place cardboard washer over polished face and use piece of 3/4" standard pipe for pressing purposes. See Figure 9.
 - Dispose of cardboard washer and clean surface of seat.
 - Clean motor shaft.

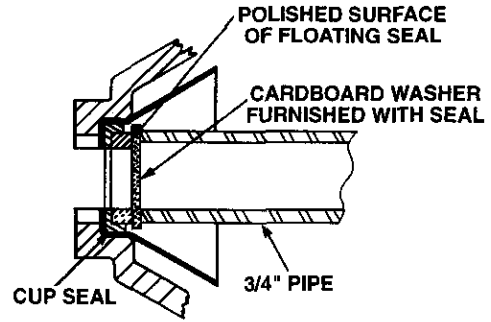

Figure 9

- Reassemble seal plate to motor flange. **BE SURE** it is right side up: index pins should be down; seal plate is marked at top. See Figures 10A and 10B.

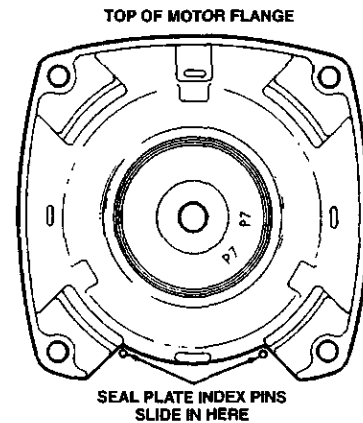

Figure 10A

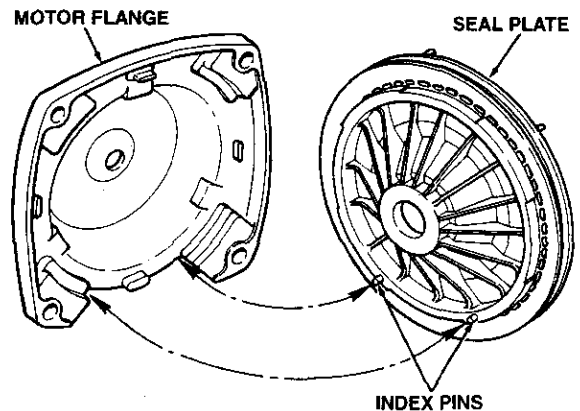

Figure 10B

- Apply detergent solution to inside diameter of rotating seal member.
- Slide rotating member on shaft until rubber drive ring hits shaft shoulder.

NOTE: Be sure you do not chip or scratch seal face on shaft shoulder or seal will leak!

OPERATION

- I. Screw impeller on shaft (clockwise) while holding shaft with 7/16" open end wrench on shaft flats. This will automatically locate seal in place. See Figure 11.

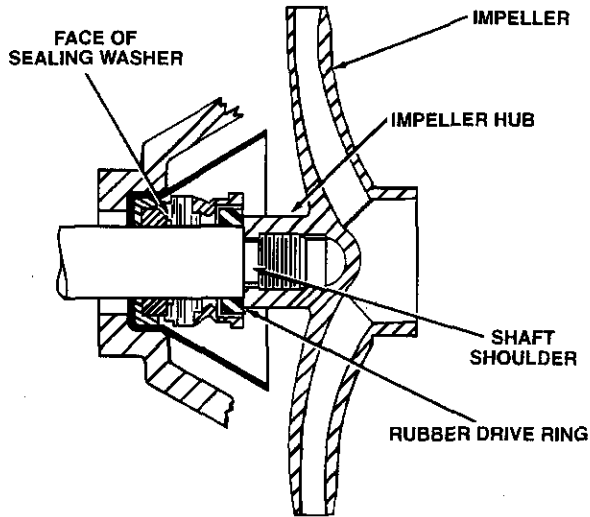

Figure 11

- J. Remount diffuser on seal plate. Be sure diffuser is right side up as follows (see Figures 13 and 14).
- Rib next to priming hole should be at six o'clock position;
 - Part number (N1-28P) should be between nine o'clock and ten o'clock.
 - Both mounting screws must engage screw holes in seal plate. See Figure 12.
 - Be sure rubber pad (Figure 12; Key No. 8, Page 12) stays in place on top of diffuser.

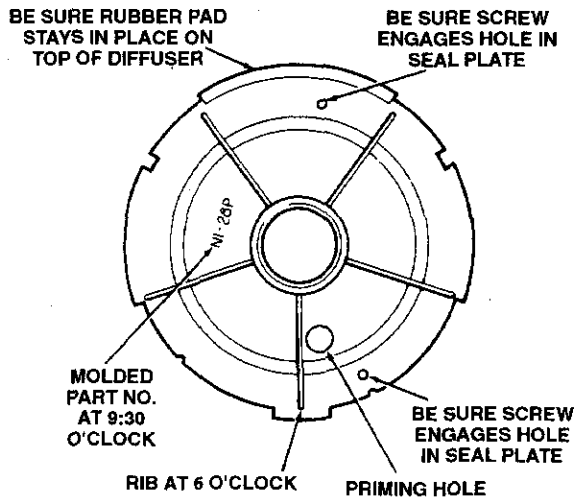

Figure 12

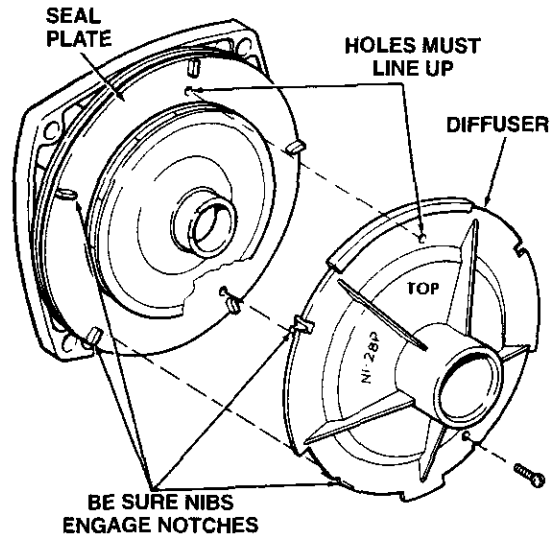

Figure 13

Installing Copper Insert

NOTE: If the copper insert (Key No. 4, Page 12) moves or shifts during seal removal, it should be removed and reinstalled.

- Remove copper insert as shown in Figure 14. do not deform.

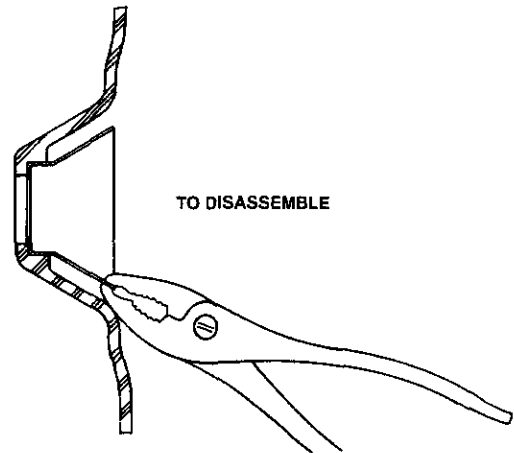

Figure 14

- Replace copper insert:
 - Clean off surplus Permatex* from around insert cavity. Be careful not to scratch or mark the machined bore. It is important that this area be clean no no old Permatex lodges behind the new insert and causes improper seating.

* "Permatex" is a registered trademark of Permatex Co. Inc.

OPERATION

- B. Place a small amount of No. 2 non-hardening Permatex on surface of insert as shown. Smooth out with finger. See Figure 15.

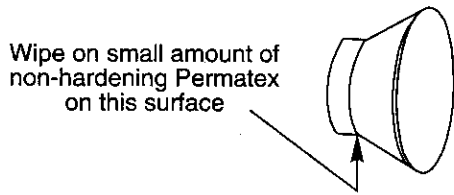

Figure 15

- C. Pull insert into cavity as shown in Figure 16.

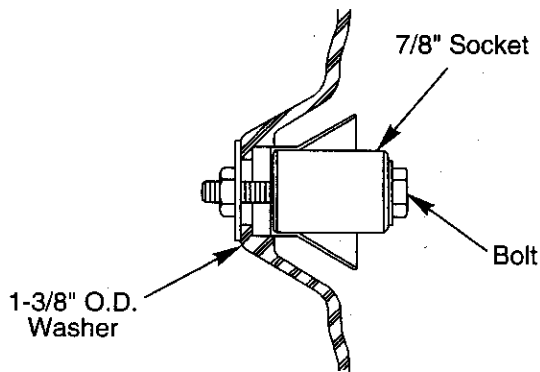

Figure 16

- D. Clean out any surplus Permatex from insert cavity where new seal will be located. See Figure 17.

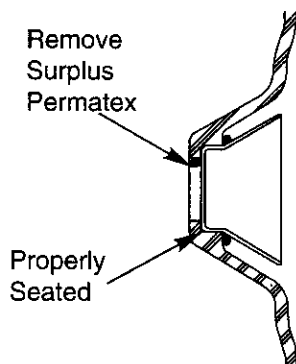

Figure 17

Cleaning Impeller

1. Follow steps 1A through 1D under "Disassembly and Assembly of Pump" on Page 7.
2. Remove diffuser and impeller from pump per instructions under "Removing Motor for Service and Replacing Shaft Seal" on Page 7.
3. Clean impeller and reassemble impeller and diffuser per instructions under "Removing Motor for Service and Replacing Shaft Seal" on Page 7.

Cleaning Shallow Well Jet

To remove debris from venturi or nozzle, proceed as follows:

1. Disassemble pump per instructions on Page 7.
2. Turn venturi counterclockwise and remove it. The nozzle is now exposed. Remove it using a 5/8" hex socket wrench with extension. Turn counterclockwise. If socket wrench is not available, insert an ice pick or similar pointed tool carefully into the nozzle. This will dislodge debris.
3. Flush out the debris by running water through the nozzle in the same direction as the dislodging tool was inserted.
4. Replace nozzle and venturi. **Do not overtighten!**
5. Reassemble per pump instructions on Page 7.

HELPFUL HINTS

How to Handle a Gaseous Well

In some areas well water contains gases which must be allowed to escape before the water is used. This can be done as shown in Figure 18.

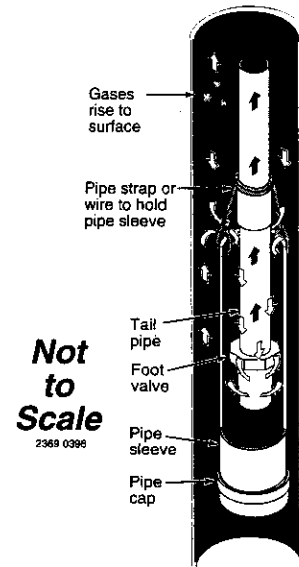

Figure 18

A good way of delivering gas-free water is to suspend a pipe, closed at the bottom and open at the top, surrounding the suction pipe. Since the gases rise in the well casing, the water sucked down through the pipe and into the suction pipe is free of gas. This type of well must be vented to the outside of any enclosure.

Air Control in Flowing Wells

Flowing wells, or wells with little or no drawdown, could create a special problem in air control in the operation of your water system.

In such cases, install a Captive Air® Tank. It does not require any air control.

TROUBLESHOOTING CHART

SYMPTOM	POSSIBLE CAUSE(S)	CORRECTIVE ACTION
Motor will not run	<ol style="list-style-type: none"> 1. Disconnect switch is off 2. Fuse is blown 3. Starting switch is defective 4. Wires at motor are loose, disconnected, or wired incorrectly 5. Pressure switch contacts are dirty 	<ol style="list-style-type: none"> 1. Be sure switch is on 2. Replace fuse 3. Replace starting switch 4. Refer to instructions on wiring. Check and tighten all wiring. 5. Clean by sliding pieces of plain paper between contacts
Motor runs hot and overload kicks off	<ol style="list-style-type: none"> 1. Motor is wired incorrectly 2. Voltage is too low 3. Pump cycles too frequently 	<ol style="list-style-type: none"> 1. Refer to instructions on wiring 2. Check with power company. Install heavier wiring if wire size is too small. See wiring instructions 3. See section below on too frequent cycling
Motor runs but no water is delivered	<ol style="list-style-type: none"> 1. Pump in new installation did not pick up prime through: <ol style="list-style-type: none"> a. Improper priming b. Air leaks c. Leaking foot valve 2. Pump has lost prime through: <ol style="list-style-type: none"> a. Air leaks b. Water level below suction of pump 3. Jet or impeller is plugged 4. Check valve or foot valve is stuck in closed position 5. Pipes are frozen 6. Foot valve and/or strainer are buried in sand or mud 	<ol style="list-style-type: none"> 1. In new installation: <ol style="list-style-type: none"> a. Re-prime according to instructions b. Check all connections on suction line, air volume control, and jet c. Replace foot valve 2. In installation already in use: <ol style="list-style-type: none"> a. Check all connections on suction line, air volume control, jet and shaft seal b. Lower suction line into water and re-prime. If receding water level in well exceeds suction lift, a deep well pump is needed 3. Clean jet or impeller according to instructions 4. Replace check valve or foot valve 5. Thaw pipes. Bury pipes below frost line. Heat pit or pump house. 6. Raise foot valve and/or strainer above well bottom
Pump does not deliver water to full capacity (Also check point 3 immediately above)	<ol style="list-style-type: none"> 1. Water level in well is lower than estimated 2. Steel piping (if used) is corroded or lined, causing excess friction 3. Offset piping is too small in size 	<ol style="list-style-type: none"> 1. A deep well jet pump may be needed (over 20 ft. to water) 2. Replace with plastic pipe where possible, otherwise with new steel pipe 3. Use larger offset piping
Pump pumps water but does not shut off	<ol style="list-style-type: none"> 1. Pressure switch is out of adjustment or contacts are "frozen" 2. Faucets have been left open 3. Jet or impeller is clogged 4. Water level in well is lower than estimated 5. Motor is wired incorrectly 	<ol style="list-style-type: none"> 1. Adjust or replace pressure switch 2. Close faucets 3. Clean jet or impeller 4. Check possibility of using a deep well jet pump 5. Refer to instructions on wiring
Pump cycles too frequently	<ol style="list-style-type: none"> 1. Standard pressure tank is waterlogged and has no air cushion 2. Pipe leak 3. Faucets or valves are open 4. Foot valve leaks 5. Pressure switch is out of adjustment 6. Air charge too low in Captive Air® Tank 	<ol style="list-style-type: none"> 1. Drain tank to air volume control tapping. Check air volume control for defects. Check for air leaks at any connection 2. Check connections 3. Close faucets or valves 4. Replace foot valve 5. Replace pressure switch 6. Disconnect electrical power and open faucets until all pressure is relieved. Using automobile tire pressure gauge, check air pressure in tank at the valve stem located at top of tank. If air pressure is lower, pump air into tank from outside source until proper air pressure is reached. Check air valve for leaks, using soapy solution, and replace core if necessary.
Air spurts from faucets	<ol style="list-style-type: none"> 1. Pump is picking up prime 2. Leak in suction side of pump 3. Well is gaseous 4. Intermittent over-pumping of well 	<ol style="list-style-type: none"> 1. As soon as pump picks up prime, all air will be ejected 2. Check suction piping 3. Change installation as described in manual 4. Lower foot valve if possible, otherwise restrict discharge side of pump

REPAIR PARTS

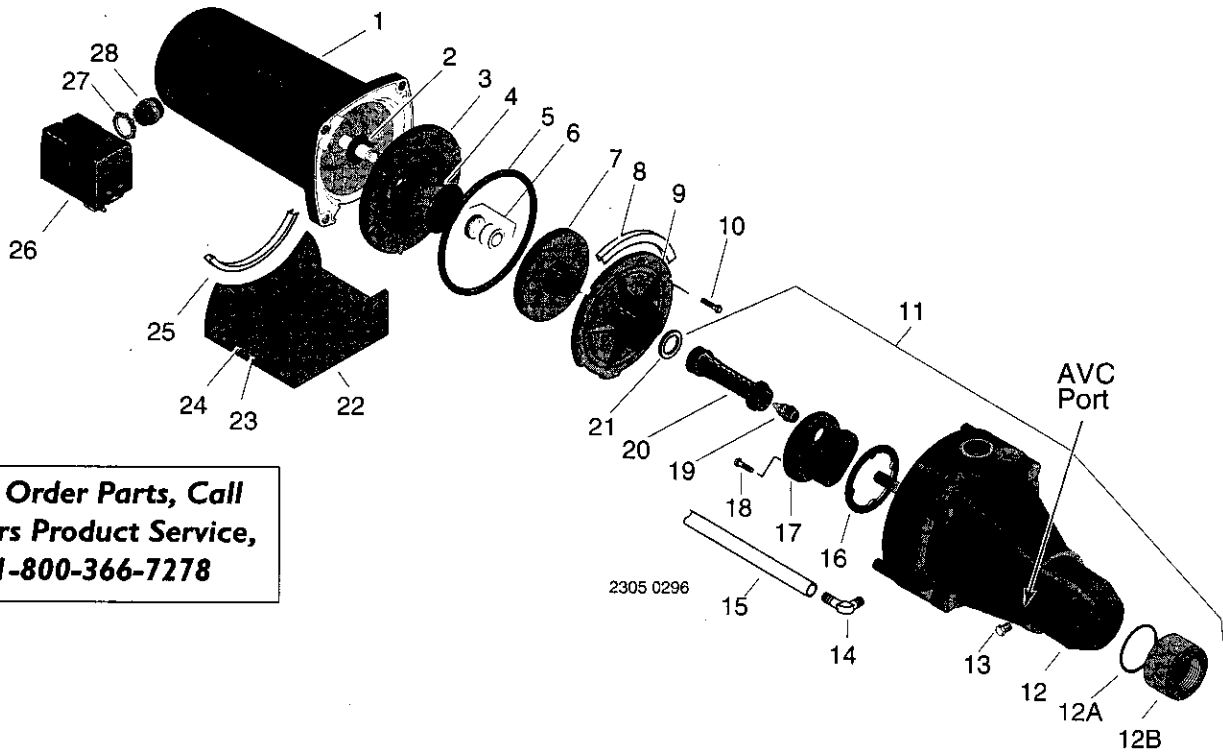

**To Order Parts, Call
Sears Product Service,
1-800-366-7278**

Model 390.2508

Key No.	Part Number	Qty. Used	Description
1#	J218-953C	1	Motor - 115/230V
2	17351-0009	1	Water Slinger
3*	N203-12P	1	Seal Plate Assembly
4	J3-2	1	Seal Plate Insert
5	U9-390	1	O-Ring
6	U109-6A	1	Shaft Seal
7	J105-40PF	1	Impeller
8	C35-41	1	Rubber Pad
9	N1-28P	1	Diffuser
10	U30-738SS	2	Capscrew #10-16 Hex Head
11**	N176-35PE	1	Pump Body Assembly
12	N76-35PE	1	Pump Body
12A	U9-226	1	O-Ring
12B	N166-5P	1	Check Valve
13†	-	1	Pipe Plug 1/8" NPT
14	U111-212T	2	90° Hose Barb
15	U37-669P	1	Switch Tube
16	J20-18	1	Gasket
17	N76-29P	1	Pump Body Jet Insert
18	U30-742SS	4	Capscrew #10-16
19	N34P-19	1	Nozzle #45
20	N32P-66	1	Venturi
21	U9-201	1	O-Ring
22	J104-9F	1	Base Assembly Painted
23†	-	4	Lock Washer 3/8"
24†	-	4	Nut 3/8" - 16
25	C35-5	1	Rubber Pad
26	2781	1	Pressure switch
27†	-	1	Locknut 1/2"
28	L43-5C	1	Connector 1/2"

For repair or service to motors, always give the motor model number and any other data found on the motor model plate.

* Includes Key Nos. 4 and 5.

** Includes Key Nos. 12, 12A, 12B, and 16 through 21.

† Standard hardware item, may be purchased locally.

SEARS

OWNER'S MANUAL

MODEL NO.
390.2508

The model number of your Shallow Well Jet Pump will be found on a plate attached to the pump discharge connection.

When requesting service or ordering parts, always give the following information:

- Product Type
- Model Number
- Part Number
- Part Description

CRAFTSMAN[®] HYDROGLASS[®] SHALLOW WELL JET PUMP

For the repair or replacement parts you need

Call 7 am - 7 pm, 7 days a week

1-800-366-PART

(1-800-366-7278)

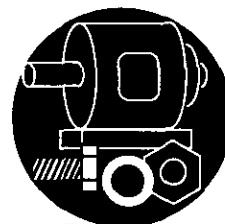

For in-home major brand repair service

Call 24 hours a day, 7 days a week

1-800-4-REPAIR

(1-800-473-7247)



**For the location of a
Sears Repair Service Center in your area**

Call 24 hours a day, 7 days a week

1-800-488-1222



**For information on purchasing a Sears
Maintenance Agreement or to inquire
about an existing Agreement**

call 9 am - 5 pm, Monday-Saturday

1-800-827-6655



SEARS
REPAIR SERVICES
America's Repair Specialists

Sears, Roebuck and Co., Hoffman Estates, IL 60179 U.S.A.