

SEARS

OWNER'S MANUAL

MODEL NO.
390.2521

CAUTION:
Read and Follow
All Safety Rules and
Operating Instructions
Before First Use of
This Product.

Save This Manual For
Future Reference.



CRAFTSMAN® PROFESSIONAL 1/2 HP SHALLOW WELL WATER SYSTEM

- Safety Instructions
- Installation
- Electrical
- Maintenance
- Repair Parts

CLICK ANYWHERE on THIS PAGE to
RETURN TO WATER PUMP & TANK I&O &
REPAIR MANUALS at InspectApedia.com

Sears, Roebuck and Co., Hoffman Estates, IL 60179 U.S.A.

CONTENTS

INTRODUCTION/WARRANTY	2
PUMP PERFORMANCE	3
MAJOR COMPONENTS	3
INSTALLATION	4-5
ELECTRICAL	6-7
OPERATION	-
MAINTENANCE	8-10
HELPFUL HINTS	10
TROUBLESHOOTING GUIDE	11
REPAIR PARTS	12-14

INTRODUCTION

Please read our instructions before installing and using your Shallow Well Water System. This will help you obtain the full benefits of the quality and convenience built into this equipment. It will also help you avoid any needless service expense resulting from causes beyond our control which are not covered by our warranty.

FULL ONE YEAR WARRANTY ON CRAFTSMAN® WELL PUMP

For one year from the date of purchase, Sears will repair or replace well pump, free of charge, if defective in material or workmanship.

LIMITED WARRANTY ON CRAFTSMAN® PROFESSIONAL HYDRO-GLASS® WELL PUMP

After one year and through three years from the date of purchase, Sears will furnish, free of charge, a replacement part for any defective part. You pay labor.

FULL FIVE YEAR WARRANTY ON CRAFTSMAN® CAPTIVE AIR TANK

For five years from date of purchase, Sears will repair or replace the tank, free of charge, if defective in material or workmanship.

This warranty does not cover repairs or replacement parts necessary because of abuse or negligence, including failure to install, adjust and operate this pump according to the instructions in the owners manual.

LIMITATION OF LIABILITY

SEARS WILL NOT BE LIABLE FOR LOSS OR DAMAGE TO PROPERTY OR ANY INCIDENTAL OR CONSEQUENTIAL LOSS OR EXPENSE FROM PROPERTY DAMAGE DUE DIRECTLY OR INDIRECTLY FROM THE USE OF THIS PRODUCT.

Some states do not allow the exclusion or limitation of incidental or consequential damages, so the above limitation or exclusion may not apply to you.

WARRANTY SERVICE IS AVAILABLE BY SIMPLY CONTACTING THE NEAREST SEARS SERVICE CENTER/DEPARTMENT IN THE UNITED STATES.

This warranty applies only while this product is in the United States.

This warranty gives you specific legal rights, and you may also have other rights which vary from state to state.

Sears, Roebuck and Co., Dept. 817WA, Hoffman Estates, IL 60179

READ AND FOLLOW SAFETY INSTRUCTIONS!

Carefully read and follow all safety instructions in this manual or on pump.

⚠ This is the safety alert symbol. When you see this symbol on your pump or in this manual, look for one of the following signal words and be alert to the potential for personal injury!

⚠ DANGER warns about hazards that **will** cause serious personal injury, death or major property damage if ignored.

⚠ WARNING warns about hazards that **will** or **can** cause serious personal injury, death or major property damage if ignored.

⚠ CAUTION warns about hazards that **will** or **can** cause minor personal injury or property damage if ignored.

The word **NOTICE** indicates special instructions which are important but not related to hazards.

⚠ CAUTION Never run pump dry. Running pump without water may cause pump to overheat, damaging seal and possibly causing burns to persons handling pump. Fill pump with water before starting.

⚠ WARNING Never run pump against closed discharge. To do so can boil water inside pump, causing hazardous pressure in unit, risk of explosion and possibly scalding persons handling pump.

⚠ CAUTION Motor normally operates at high temperature and will be too hot to touch. It is protected from heat damage during operation by an automatic internal cutoff switch. Before handling pump or motor, stop motor and allow to cool for 20 minutes.

- 1 To avoid risk of serious bodily injury and property damage, read safety instructions carefully before installing pump.
- 2 Follow local and/or national plumbing and electrical codes when installing pump.
- 3 Keep well covered while installing pump to prevent leaves and other debris from falling into well, contaminating well and possibly damaging pump.
- 4 Protect pump and piping system from freezing. Allowing pump or water system to freeze could severely damage pump and voids warranty.

⚠ WARNING To avoid serious injury and equipment damage, limit system pressure to 100 pounds per square inch (PSI) or below at all times. Overpressure can cause tank blowup; install relief valve capable of passing full pump volume at 100 PSI.

- 5 With a new well, test well for purity before use. Consult local Health Department for procedure.

⚠ WARNING Hazardous voltage. Can shock, burn, cause death, or start fires.

SAFETY INSTRUCTIONS (Continued)

- | | |
|--|--|
| <p>6. Disconnect electrical power source before installing or working on pump.</p> <p>7. Ground pump with a ground wire run from grounding lug on motor to a grounded lead in the service panel.</p> | <p>8. Line voltage and frequency of electrical power supply must agree with motor nameplate.</p> <p>9. Use of fuses or wire smaller than size recommended in owner's manual can cause overheating, possible fires, and will void warranty.</p> |
|--|--|

TABLE I – Pump Performance (In Gallons per Minute)

NOTE: This system is designed for pumping depths of 20 feet or less.

Pump Model	Description	Suct.	Disch.	Discharge Pressure PSI	Pumping Depth in Feet			
					5'	10'	15'	20'
390.2521	1/2 HP S.W. Jet	1-1/4"	1"	40	8.2	7.3	6.2	5.0

BASIC TOOLS AND MATERIALS NEEDED

Plastic Pipe Installation

Tools

Pipe Wrenches
Screwdriver
Knife or Saw to Cut Plastic Pipe
Tire Pressure Gauge

Materials

Plastic Pipe and Fittings (as required to complete job).
Teflon Tape (DO NOT use joint compound on plastic fittings).

Galvanized Steel Pipe Installation

Tools

Pipe Wrenches
Screwdriver
Pipe Cutting and Threading Tools
Tire Pressure Gauge

Materials

Galvanized Pipe and Fittings (as required to complete job).
Pipe Joint Compound or Teflon Tape

MAJOR COMPONENTS AND WHAT THEY DO

Impeller and Jet

Impeller turns with motor shaft, causing water to fly out from its rim by centrifugal force. Impeller rotation creates a vacuum which pulls in more water. Part of the water is diverted back to the jet where it passes through the nozzle and venturi. This creates more vacuum to draw in more water. In shallow wells (less than 20 feet deep), the vacuum created at the pump is enough to pull water to the pump. Therefore, for shallow well use the jet is built into the pump.

Pre-Charged Tank

The tank serves two functions. It provides a reservoir of water under pressure and maintains a cushion of air pressure to prevent pipe hammering and possible damage to plumbing components. When water is drawn off through the house fixtures, the pressure in the tank is lowered and the pump starts.

Pressure Switch

The pressure switch provides for automatic operation. Pump starts when pressure drops to 40 pounds and stops when pressure reaches 60 pounds.

Check Valve or Foot Valve

This pump is equipped with a built-in check valve. Install a check valve **as close to well as possible** on well point installations. A foot valve must be installed **in the well** on dug or cased wells. See Figures 2A and 2B, Page 4. For long horizontal pipe runs, install check valve as close to well as possible (all types of wells).

INSTALLATION

INSTALLATION

Piping in the Well

The Shallow Well Water System can be installed on a dug well, drilled well or with a driven point. In a dug or cased well, a foot valve and strainer should be installed for easy priming. It should be installed five to ten feet below the lowest level to which the water will drop while the pump is operating (pumping water level). To keep sediment from clogging the strainer, be sure it is five to ten feet above the bottom of the well. Before installing the foot valve, make sure that it works freely.

When using a foot valve, a priming tee and plug as shown in Figure 1, are recommended.

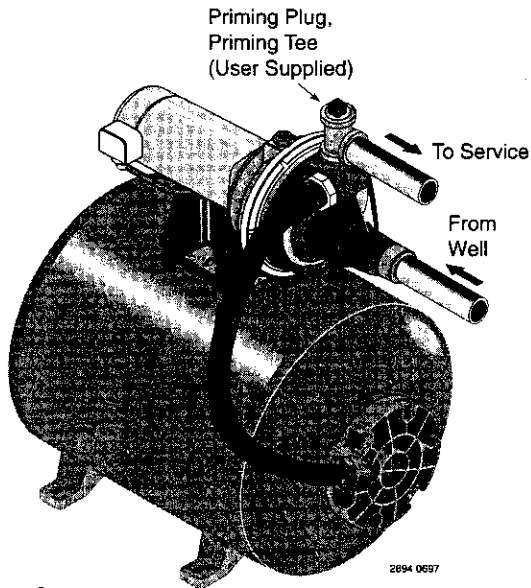

Figure 1

When installed on a driven point well, your Shallow Well Water System should have a check valve installed as shown in Figure 2A.

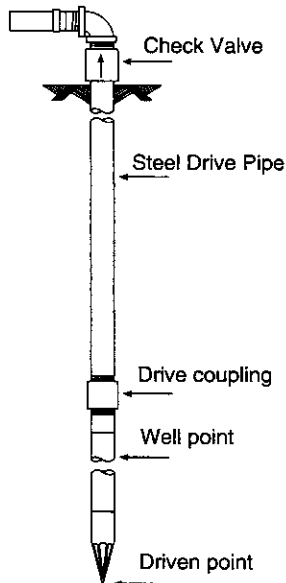

Figure 2A

For a pump at sea level mounted directly over the well, be sure the total lift from the pumping water level to the pump does not exceed 20 feet. This will be less if the pump is offset from the well.

The maximum lift of any pump decreases at the rate of about 1' less lift for every 1,000 feet of elevation above sea level. For example, at Denver, Colorado (Elev. 5,000') the pump loses five feet of lift. The maximum depth from which it would pump water would therefore be 15 feet.

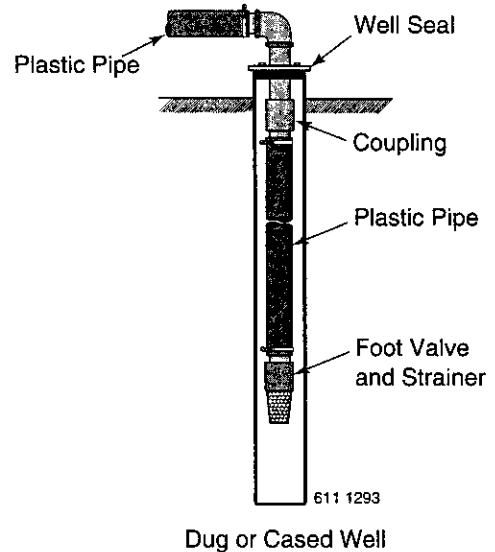

Figure 2B

PUMP/TANK INSTALLATION

Pump

NOTICE: Use Teflon tape supplied with the pump or Plasto-Joint Stik¹ for making all pipe-thread connections to the pump itself. To avoid stress-cracking, do not use pipe joint compounds on the pump.

1. Wrap male pipe threads being attached to pump with one or two layers of Teflon tape. Cover entire threaded portion of pipe.
2. Do not overtighten threaded fittings in the plastic pump. Be sure you do not try to tighten joint past thread stop in pump port!
3. If leaks occur, remove fittings, clean off old tape, rewrap with two to three layers of tape and remake the connection. If joint still leaks, replace the fittings (fittings may be undersized).
4. Be sure to support all piping connected to the System.

¹Lake Chemical Co., Chicago, Illinois

Horizontal Piping from Well to Pump

When the pump is offset more than 25 feet from the well, horizontal suction pipe size should be increased to reduce friction losses. Never install a suction pipe that is smaller than the suction tapping of the pump.

INSTALLATION

1-1/4"	1-1/2"	2"
Up to 25 Ft.	25 to 50 Ft.	50 to 200 Ft.

Discharge Pipe Sizes

When the pump is some distance from the house or point of water use, the discharge pipe size should be increased to reduce pressure losses caused by friction.

1"	1-1/4"	1-1/2"
Up to 25 Ft.	25 to 100 Ft.	100 to 600 Ft.

Tank

Tanks are pre-charged with 40 PSI air pressure at the factory. Your tank requires an air charge of 40 pounds per square inch (PSI) for proper operation; check tank pressure with tire gauge to determine if air charge needs adjustment. Tank pre-charge should be checked annually; see instructions at right.

In areas where the temperature is high for long periods of time, the tank pre-charge pressure may increase. This may reduce the tank drawdown (amount of water available per cycle). If this occurs, reduce the pre-charge pressure to two PSI below the pump cut-in setting of the pressure switch (normally to 38 PSI).

It is necessary to flush all air out of the piping system and water reservoir portion of the pre-charged tank. This is re-

quired on new installations, pumps requiring repriming and pumps that have been disassembled for service. Do this as follows:

1. Open faucets furthest from tank and allow pump to operate.
2. Air in the system will cause a sputtering flow; allow faucets to run until you have a steady, air free stream.
3. Open and close faucets repeatedly until you are sure all air has been removed.
4. If stream does not become steady, air may be leaking into the system; check for leaks in the piping on the suction side of the pump.

NOTICE: To prevent waterlogging, check tank air charge annually.

To Check Tank Air Charge

If drawdown (amount of water available per cycle) decreases significantly, check as follows:

1. To check air charge in tank, shut off electric power to pump, open faucet near tank, and drain completely.
2. At the air valve in top of tank, check air pressure with standard tire gauge. Air pressure should be the same as pump pressure switch cut-in setting (40 PSI).
3. If the air pressure is below 40 PSI, add air to the tank. Use an air compressor or a portable air storage tank.
4. Use soap or liquid detergent to check for air leaks around air valve. Continuous bubbling indicates a leak. If necessary, install new core in air valve. This is the same as those used for automobile tubeless tires.

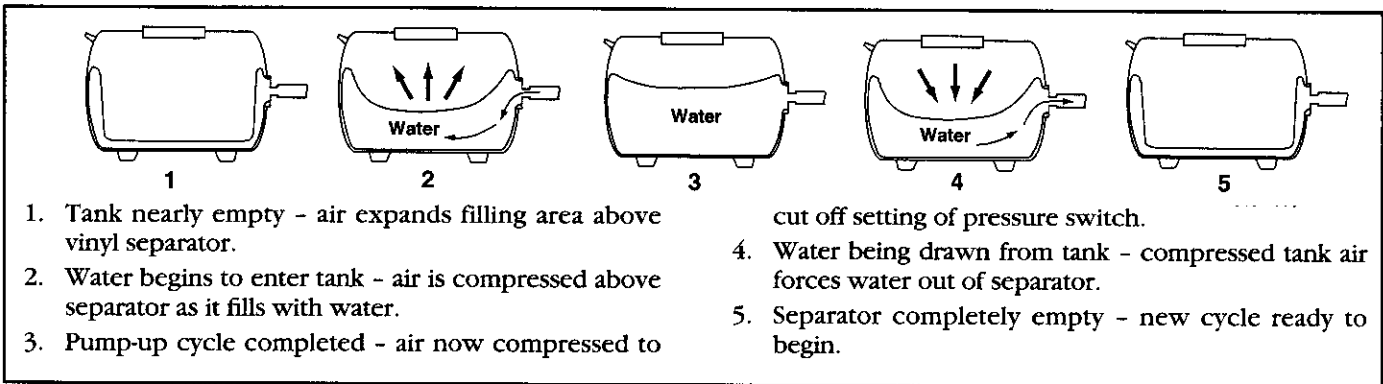

Figure 3

ELECTRICAL

⚠ Disconnect power before working on pump, motor, pressure switch, or wiring.

Motor Switch Settings

If the motor can operate at either 115 or 230 volts, it is set at the factory to 230 volts. Do not change motor voltage setting if line voltage is 230 volts, or if you have a single voltage motor.

NOTICE: Never wire a 115 volt motor to a 230 volt line.

Remove Motor End Cover

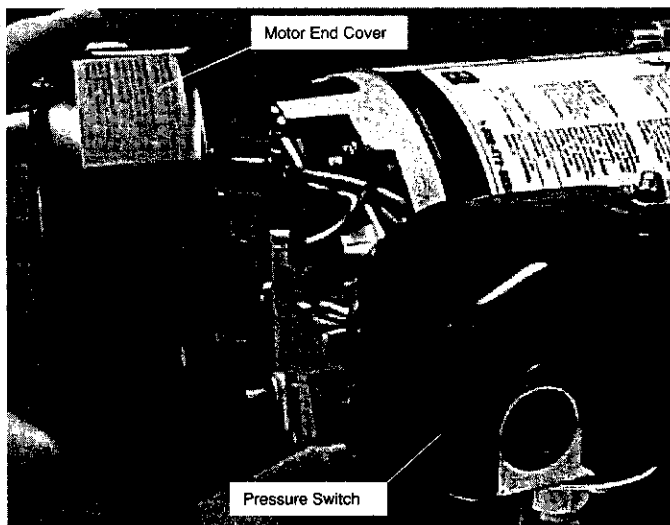

Figure 4 – Removing Motor End Cover

You will need to remove the motor end cover to change the voltage setting. The illustration above also shows the pressure switch. If the power supply connection still needs to be made, the pressure switch cover will need to be removed.

Your motor terminal board (located under the motor end cover) should look like the one at right.

Dial Type Voltage Selector

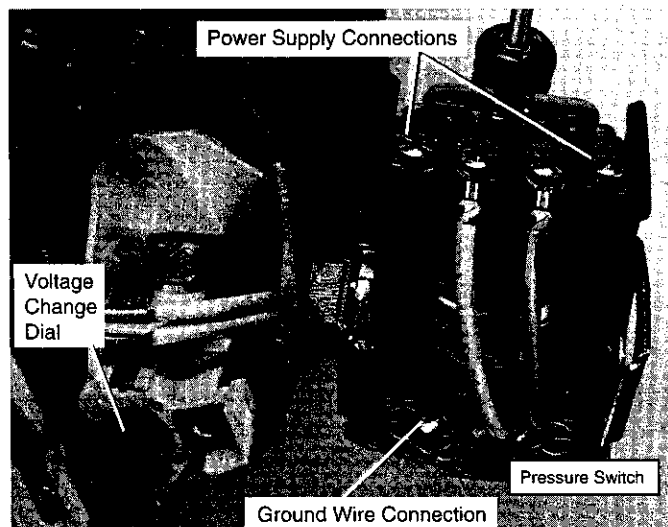

Figure 5 – Voltage Set To 230 Volts, Dial Type

To change to 115 volts:

1. Make sure power is off.
2. Turn the dial counter-clockwise until 115 shows in the dial window.
3. Reinstall the Motor end cover
4. Go to Wiring Connections below.

⚠ WARNING Hazardous voltage. Can shock, burn, or kill. Connect ground wire before connecting power supply wires. Use the wire size (including the ground wire) specified in the wiring chart. If possible, connect the pump to a separate branch circuit with no other appliances on it.

⚠ WARNING Explosion hazard. Do not ground to a gas supply line.

WIRING CONNECTIONS

⚠ WARNING Fire hazard. Incorrect voltage can cause a fire or seriously damage the motor and voids the warranty. The supply voltage must be within $\pm 10\%$ of the motor name-plate voltage.

ELECTRICAL

NOTICE: Dual-voltage motors are factory wired for 230 volts. If necessary, reconnect the motor for 115 volts, as shown. Do not alter the wiring in single voltage motors.

Install, ground, wire, and maintain your pump in compliance with the National Electrical Code (NEC) or the Canadian Electrical Code (CEC), as applicable, and with all local codes and ordinances that apply. Consult your local building inspector for code information.

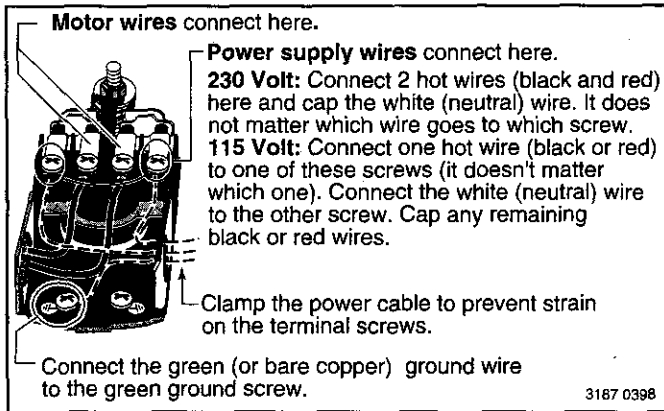

Figure 6 – Pressure Switch Wiring

Connection Procedure:

1. Connect the ground wire first as shown in Figure 4. The ground wire must be a solid copper wire at least as large as the power supply wires.
2. There must be a solid metal connection between the pressure switch and the motor for motor grounding protection. If the pressure switch is not connected to the motor, connect the green ground screw in the switch to the green ground screw under the motor end cover. Use a solid copper wire at least as large as the power supply wires.
3. Connect the ground wire to a grounded lead in a service panel, to a metal underground water pipe, to a metal well casing at least ten feet (3M) long, or to a ground electrode provided by the power company or the hydro authority.
4. Connect the power supply wires to the pressure switch as shown in Figure 6.

Table II Wiring Chart – Recommended Wire and Fuse Sizes

Motor Horsepower	Volts	Max. Load Amps.	Branch Fuse* Rating Amps	Distance in Feet from Motor to Meter				
				0' to 100'	101' to 200'	201' to 300'	301' to 400'	401' to 500'
				Wire Size				
1/2	115/230	10.5/5.2	15/15	14/14	10/14	8/14	6/14	6/12

OPERATION

Priming the Pump

NOTICE: To properly prime the pump, install a pipe tee in the discharge piping (see Figure 1, Page 4).

To prevent damage to internal parts, do not start motor until pump has been filled with water.

To prime pump:

1. Remove priming plug (Purchase separately; Figure 1, Page 4).
2. Fill pump with water.
3. Replace priming plug, using Teflon tape or Plasto-Joint Stik² on plug threads; tighten plug.
4. Start the pump. Water should be pumped in 1-2 minutes. If not, repeat steps 1, 2 and 3.

On shallow depths to water (10 feet or less), the pump will probably prime the first time after the following steps 1 through 4 above.

From 10 to 20 foot depths, you might have to shut off the pump and repeat steps 1, 2 and 3 several times.

5. If, after priming pump several times, no water is pumped, check the following:
 - A. Be sure suction pipe is in the water.
 - B. Be sure suction pipe does not leak.
 - C. Be sure that pump is not trying to lift water too high (see "Piping in the Well", Page 4).
 - D. As long as foot valve and check valve function correctly and suction pipe does not develop leaks, pump should not need repriming in normal service.

² Lake Chemical Co., Chicago, Illinois

MAINTENANCE

Lubrication

It is not necessary to lubricate the pump or its motor. The motor bearings are lubricated for life. The mechanical shaft seal in the pump is water lubricated and self-adjusting.

Draining for Winter

▲WARNING Risk of electric shock. Disconnect power before working on unit.

Pump should be drained whenever it is disconnected from service or is in danger of freezing.

1. DISCONNECT POWER.
2. Open faucet and relieve all pressure on system before proceeding.
3. Disconnect pressure switch tube (Key No. 17, Page 12) at barbed elbow on pressure switch (Key No. 28) and allow tube to drain.
4. Open draincock (Key No. 22, Page 12) on pump body and allow pump to drain.
5. Remove priming plug to vent pump; disconnect hose (Key No. 6, Page 14) at tank end and drain pressure tank and all piping to a point below the frost line.
6. Be sure to drain any piping that may be cut off from normal system drain due to check valve installation.

Vinyl Bag Removal

▲WARNING Be sure ALL air pressure has been released from tank before removing nuts from flange. Failure to do this may result in serious or fatal injury. Do not attempt to open tank unless all pressure has been relieved!

▲WARNING Risk of electric shock. Disconnect power before working on unit.

1. DISCONNECT POWER TO PUMP.
2. Drain system as follows:
 - A. Open faucet closest to tank.
 - B. Open draincock (Key No. 22, Page 12) on pump body.
 - C. Remove hose (Key No. 6, Page 14) from tank flange.
3. Relieve (expel) ALL air pressure in system by removing valve core.
4. Disconnect outside piping from tank and pump.

▲WARNING To avoid serious or fatal injury, be sure all air pressure has been released from tank before proceeding to step 5.

5. Remove nuts and washers from tank inlet flange (Key No. 2, Page 14). Tap inlet flange to break seal. Remove flange.
6. Wherever convenient, hold bag with pliers and cut with single-edge razor blade or sharp knife. Bag will not come out in one piece. Continue pulling and cutting until bag is removed.
7. Clean and dry inside of tank.
8. Place replacement bag on a clean surface with opening

up. Flatten bag and force air out.

9. Tightly roll bag towards center opening.
10. Before center opening is covered up, force air out of remaining portion of bag. Finish rolling bag.
11. To make bag easier to insert into tank, sprinkle outside of bag with talcum powder.
12. Being careful not to break valve, stand tank on end. Push tightly rolled bag into tank.
13. Reach into bag and push out sidewalls. You need not remove all wrinkles.
14. Clean center opening ring on bag and lip on tank.
15. Pull ring on bag through tank opening and fit over tank lip. BE SURE it seats properly in groove on tank lip.
16. Clean sealing surface of inlet flange and place on studs.
17. **NOTICE:** Tighten nuts as follows:
 - A. Hand tighten all nuts.
 - B. Tighten one nut snug.
 - C. Tighten opposite nut snug.
 - D. Proceed, tightening opposite pairs to a snug fit.
 - E. Recheck all nuts, using same pattern. Be sure all nuts are tight and you have a good seal.
- NOTICE:** Do not overtighten; you may twist studs off of tank. If you have a torque wrench, tighten to 85 inch-pounds torque.
18. Stand tank on feet and reconnect piping.
19. Recharge tank to proper air pressure (see Page 5).
20. Reconnect hoses and pressure switch tube; prime pump (see Page 6).

Air Valve Replacement

1. Follow steps 1 through 5 under "Vinyl Bag Removal".
2. Cut valve off as close to tank as possible. Push remaining portion back into tank.
3. Tip tank on end and BE SURE all water is drained from bag.
4. Carefully remove bag ring from lip on tank opening and push bag ring back into tank; reach in around it and remove cut off portion of valve from tank.
5. Wipe a thin film of soapy solution on replacement valve and from inside tank insert in hole in top of tank.
6. Pull valve through hole with pliers or a valve tool (available at your local filling station or Automotive Center).
7. Follow steps 14 through 20 under "Vinyl Bag Removal" to reinstall bag in tank.

Testing for Bag Leakage

1. Follow steps 1 through 4 under "Vinyl Bag Removal".
2. Tip tank on end, valve down. Be careful not to break valve!
3. If bag leaks, water will run out of valve. If so, replace bag as instructed above.

MAINTENANCE

DISASSEMBLY AND ASSEMBLY OF PUMP

▲WARNING Risk of electric shock. Ground unit and disconnect power before attempting any work on pump or motor.

Your Sears pump is designed for ease in servicing. Should repair or replacement of the motor or seal be needed, the pump and piping do not need to be disconnected or disturbed.

1. Disassemble pump as follows:
 - A. Disconnect power.
 - B. Drain pump by opening drain cock. Remove pressure switch tubing from fitting on top of pump.

▲WARNING To avoid serious injury, release all pressure from system before attempting to remove clamp from pump.

- C. Remove clamp, Key No. 10, Page 12.
 - D. Remove pump base mounting bolts. Motor assembly and back half assembly of pump can be pulled away from front half.
 - E. Remove "O" rings.
2. Reassembly of pump.
 - A. Clean "O" rings and "O" ring grooves.
 - B. Lubricate "O" rings with petroleum jelly, and place in grooves.
 - C. Slide pump halves together.
 - D. Clean inside of clamp. Place clamp around pump halves. Alternately tighten clamp screw and tap clamp around outside with plastic mallet. This will insure proper seating of "O" ring and clamp.
 - E. Assemble base mounting bolts. Connect pressure switch tubing and close drain cock.
 - F. Prime pump and turn on power.
 - G. Check for leaks.

Removing Motor for Service and Replacing Shaft Seal

If it is necessary to separate motor and seal plate, always replace the shaft seal. We suggest you purchase this item, U109-6A, and have it on hand for future use.

NOTICE: The seal consists of two parts, a rotating member and a ceramic seat. The surfaces of the seal are easily damaged. Read instructions carefully.

1. Disassemble pump per instructions above.
2. Remove diffuser and impeller as follows (Key Nos. 8 and 9, Page 12).
 - A. Remove screws holding diffuser.
 - B. Loosen two screws and remove motor canopy from motor.
 - C. Place 7/16" open end wrench on motor shaft flat.
 - D. Turn impeller counterclockwise when facing it.
3. Remove pump back half from motor by unscrewing four (4) nuts. Pry back half off motor by inserting two (2)

screwdrivers between the back pump half and the motor flange. This will force rotating portion of seal off shaft. See Figure 7.

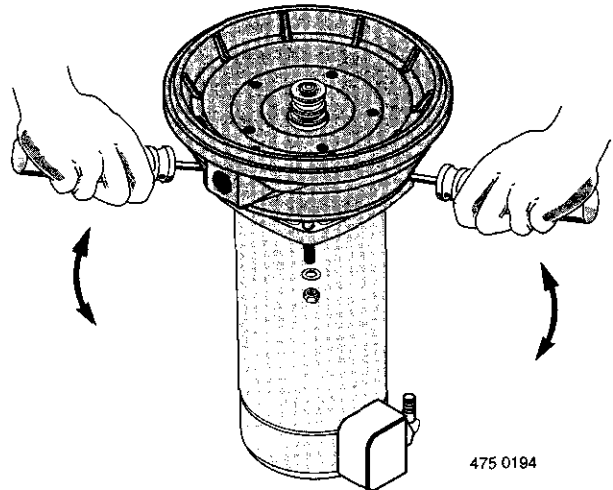

Figure 7

4. Place back half of pump on flat surface and tap out ceramic seat. See Figure 8.

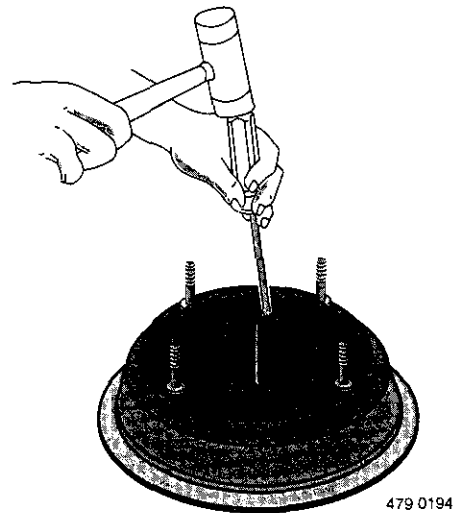

Figure 8

5. Clean seal cavity.
6. Install new seal.
 - A. Clean polished surface of ceramic seat with clean cloth.

MAINTENANCE / HELPFUL HINTS

- B. Wet outer edge of "O" Ring with detergent solution.
- C. With finger pressure press seat firmly and squarely into cavity. See Figure 9A. Polished face of seat faces inside of pump. If seat will not locate properly, place cardboard washer over polished face and use piece of 3/4" standard pipe for pressing purposes. See Figure 9B.

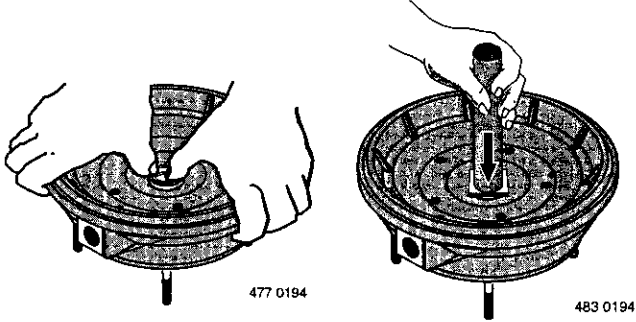

Figure 9A

Figure 9B

- D. Dispose of cardboard washer and clean surface of seat.
- E. Clean motor shaft.
- F. Reassemble back half of pump to motor.
- G. Apply detergent solution to inside diameter of rotating seal member.
- H. Slide rotating member on shaft until rubber drive ring hits shaft shoulder. NOTICE: BE SURE you do not chip or scratch seal face on shaft shoulder or seal will leak!
- I. Screw impeller on shaft (clockwise) while holding shaft with 7/16" open end wrench on shaft flats. This will automatically locate seal in place. See Figure 10.

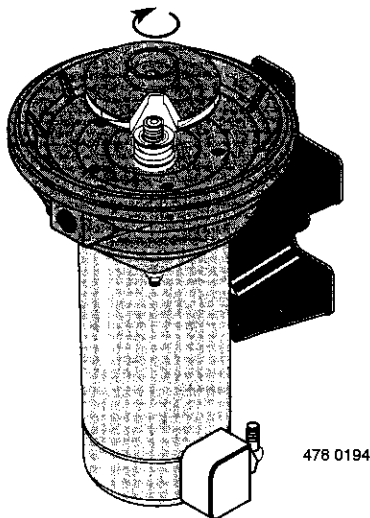

Figure 10

- J. Remount diffuser on seal plate.

Cleaning Impeller

1. Follow steps 1A through 1E under "Disassembly and Assembly of Pump" on Page 8.
2. Remove diffuser and impeller from pump per instructions under "Removing Motor for Service and Replacing Shaft Seal" on Page 9.
3. Clean impeller and reassemble impeller and diffuser per instructions under "Removing Motor for Service and Replacing Shaft Seal" on Pages 9 and 10.

Cleaning Shallow Well Jet

To remove debris from venturi or nozzle, proceed as follows:

1. Disassemble pump per instructions on Page 9.
2. Turn venturi counterclockwise and remove it. The nozzle is now exposed. Remove it using a 5/8" hex socket wrench with extension. Turn counterclockwise. If socket wrench is not available, insert an ice pick or similar pointed tool carefully into the nozzle. This will dislodge debris.
3. Flush out the debris by running water through the nozzle in the same direction as the dislodging tool was inserted.
4. Reinstall nozzle and venturi. **Do not overtighten!**
5. Reassemble pump per instructions on Page 9.

How to Handle a Gaseous Well

In some areas well water contains gases which must be allowed to escape before the water is used. This can be done as shown in Figure 11.

A good way of delivering gas-free water is to suspend a pipe, closed at the bottom and open at the top, surrounding the suction pipe. Since the gases rise in the well casing, the water sucked down through the pipe and into the suction pipe is free of gas. This type of well must be vented to the outside of any enclosure.

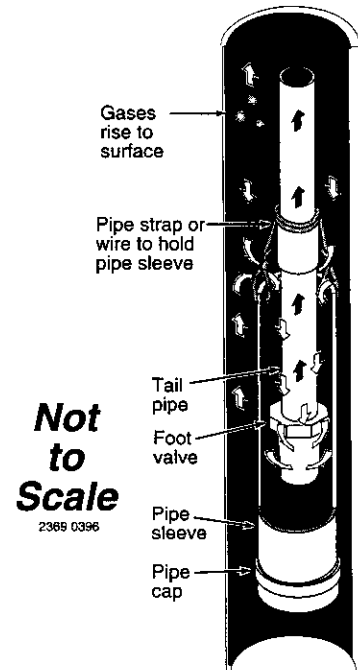

Figure 11

TROUBLESHOOTING GUIDE

TROUBLE	POSSIBLE CAUSES	REMEDIES
Motor will not run	<ol style="list-style-type: none"> 1. Disconnect switch is off 2. Fuse is blown 3. Starting switch is defective 4. Wires at motor are loose, disconnected, or wired incorrectly *5. Motor is wired incorrectly 6. Pressure switch contacts are dirty 	<ol style="list-style-type: none"> 1. Be sure switch is on 2. Replace fuse 3. Replace starting switch 4. Refer to instructions on wiring 5. Refer to instructions on wiring 6. Clean by sliding piece of plain paper between contacts
Motor runs hot and overload kicks off	<ol style="list-style-type: none"> *1. Motor is wired incorrectly 2. Voltage is too low 3. Pump cycles too frequently 	<ol style="list-style-type: none"> 1. Refer to instructions on wiring 2. Check with power company. Install heavier wiring if wire size is too small. See wiring instructions 3. See section below on too frequent cycling
Motor runs but no water is delivered (*Note: Check prime before looking for other causes. Unscrew priming plug and see if there is water in priming hole)	<ol style="list-style-type: none"> *1. Pump in a new installation did not pick up prime through: <ol style="list-style-type: none"> a. Improper priming b. Air leaks c. Leaking foot valve *2. Pump has lost its prime through: <ol style="list-style-type: none"> a. Air leaks b. Water level below suction of pump 3. Jet or impeller is plugged 4. Check valve or foot valve is stuck in closed position 5. Pipes are frozen 6. Foot valve and/or strainer are buried in sand or mud 	<ol style="list-style-type: none"> 1. In new installation: <ol style="list-style-type: none"> a. Re-prime according to instructions b. Check all connections on suction line and jet c. Replace foot valve 2. In installation already in use: <ol style="list-style-type: none"> a. Check all connections on suction line, jet and shaft seal b. Lower suction line into water and re-prime. If receding water level in a shallow well operation exceeds suction lift, a deep well pump is needed 3. Clean jet or impeller according to instructions 4. Replace check valve or foot valve 5. Thaw pipes. Bury pipes below frost line. Heat pit or pump house 6. Raise foot valve and/or strainer above well bottom
Pump does not deliver water to full capacity (also check point 3 immediately above)	<ol style="list-style-type: none"> 1. Water level in well is lower than estimated 2. Steel piping (if used) is corroded or limed, causing excess friction 3. Offset piping is too small in size 	<ol style="list-style-type: none"> 1. A deep well jet pump may be needed (over 20 ft. to water) 2. Replace with Plastic Pipe where possible, otherwise with new steel pipe 3. Use larger offset piping
Pump pumps water but does not shut off	<ol style="list-style-type: none"> 1. Pressure switch is out of adjustment or contacts are "frozen" 2. Faucets have been left open 3. Jet or impeller is clogged 4. Motor is wired incorrectly 5. Water level in well is lower than estimated 	<ol style="list-style-type: none"> 1. Adjust or replace pressure switch 2. Close faucets 3. Clean jet or impeller 4. Refer to instructions on wiring 5. Check possibility of using a deep well jet pump
Pump cycles too frequently	<ol style="list-style-type: none"> 1. Pipes leak 2. Faucets or valves are open 3. Foot valve leaks 4. Pressure switch is out of adjustment 5. Air charge too low in Captive Air® Tank 	<ol style="list-style-type: none"> 1. Check connections, replace pipe fittings 2. Close faucets or valves 3. Replace foot valve 4. Adjust or replace pressure switch 5. Disconnect electrical power and open faucets until all pressure is relieved. Using automobile tire pressure gauge, check air pressure in tank at the valve stem located at top of tank. If less than 40 pounds, pump air into tank from outside source, until 40 pounds pressure is reached. Check air valve for leaks, using soapy solution, and replace core if necessary
Air spurts from faucets	<ol style="list-style-type: none"> 1. Pump is picking up prime 2. Leak in suction side of pump 3. Well is gaseous 4. Intermittent over-pumping of well 	<ol style="list-style-type: none"> 1. As soon as pump picks up prime, all air will be ejected 2. Check suction piping, make sure joints are not sucking air 3. Change installation as described in manual 4. Lower foot valve if possible, otherwise restrict discharge side of pump
Leaks at the metal clamp <div style="border: 1px solid black; padding: 2px; display: inline-block;">▲ WARNING</div> Release all pressure in system before working on clamp!	<ol style="list-style-type: none"> 1. Loose clamps or "O" ring not sealed 	<ol style="list-style-type: none"> 1. First check the clamp tightening screw to see if it is tight. If it is tight and slight leakage still occurs, place a piece of wood on the periphery of the clamp and firmly tap the wood with a hammer. Repeat this operation around the edge of the clamp and retighten the clamp screw. If leak continues, disassemble clamp and pump halves and check to see that "O" ring is properly seated and no foreign material is on "O" ring or "O" seat. Reassemble pump.

REPAIR PARTS

Pump Only – Model 390.2521

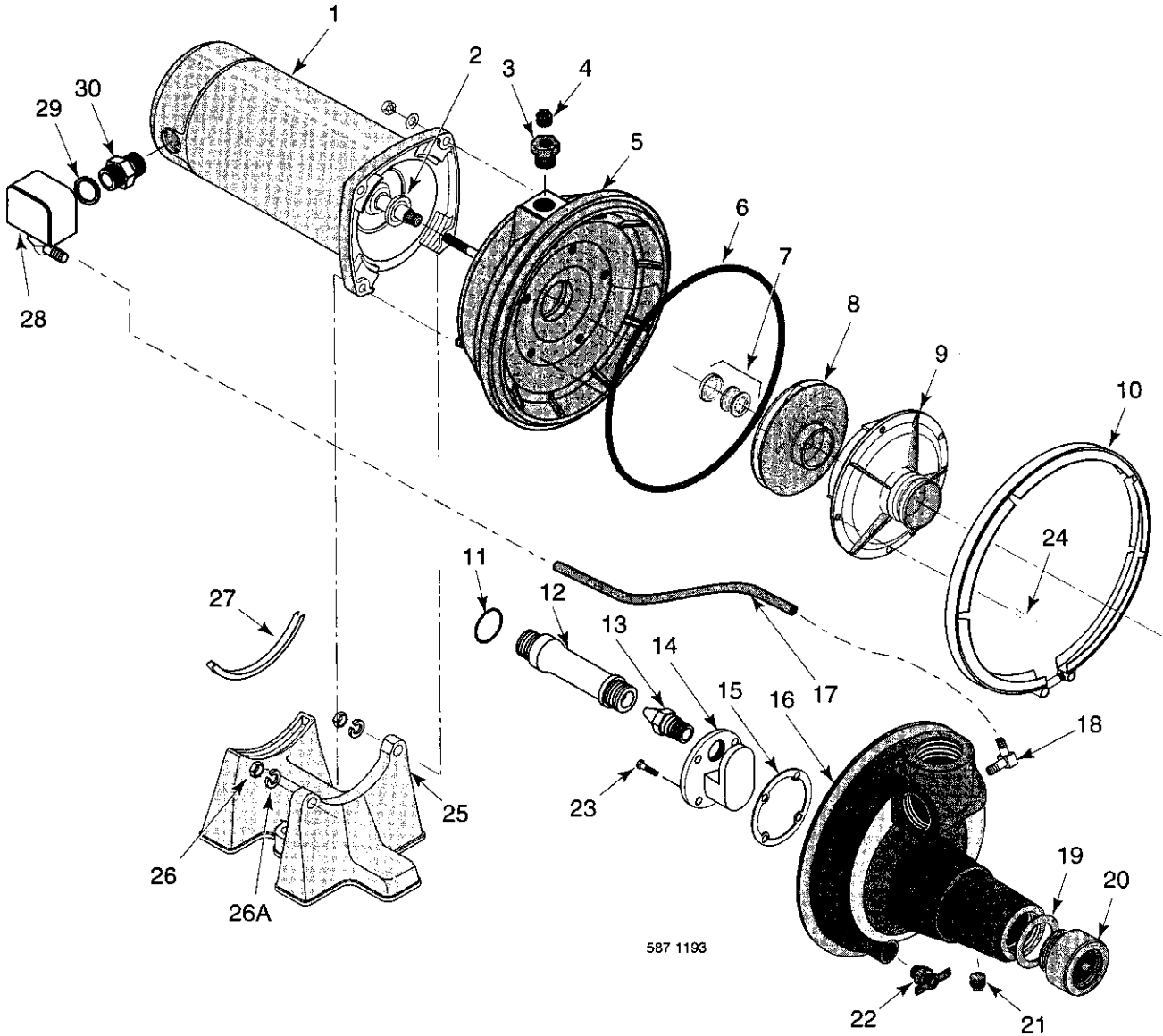

**To Order Parts in the U.S.A., Call
Sears Product Service, 1-800-366-7278**

**To Order Parts outside the U.S.A., Call
Your local Sears Service Center or Store**

REPAIR PARTS

Key No.	Model 390.2521 1/2 HP	Part Description
1**	J218-953C	Motor - 1/2 HP - 115/230V - 60 Cycle
2	17351-0009	Water Slinger
3*	-	Reducer Bushing - 1/2" x 1/8" NPT
4	WC78-41T	Pipe Plug - 1/8" NPT
5	L176-47P	Tank Body (Back Half)
6	U9-399	"O" Ring - Tank Body - 9-1/2"x 9" x 1/4"
7	U109-6A	Shaft Seal
8	J105-40PE	Impeller
9	J1-39P	Diffuser
10	C19-54SS	Clamp - Tank Body
11	U9-201	"O" Ring - Venturi - 1-3/8" x 1-1/8" x 1/8"
12	N32P-66	Venturi
13	N34P-19	Nozzle
14	N76-29P	Insert
15	J20-18	Gasket
16	N176-28PB	Tank Body Assembly (Front Half - Includes Key No's. 11, 12, 13, 14, 15, 16, 19, 20, 21, 23 and 24)
16	N76-28P	Tank Body Only - Front Half
17	U37-673P	Switch Tube
18	U111-212T	90° Hose Barb
19	U9-226	"O" Ring - Check Valve - 2-1/4" x 2" x 1/8"
20	N166-5P	Check Valve
21*	-	Pipe Plug - 1/8" NPT (2 Required)
22	U212-68T	Draincock - 1/4" NPT
23	U30-742SS	Screw - #10 - 16 x 1-1/8" (4 Required)
24	U30-542SS	Screw - #8 - 32 x 7/8" (5 Required)
25	C4-42P	Base
26*	-	Nut - 5/16" - 18 Hex Head (4 Required)
26A*	-	Lockwasher (4 Required)
27	C35-11	Motor Pad
28	2782	Pressure Switch
29*	-	Locknut - 1/2"
30	L43-5C	Connector

* Standard hardware item, may be purchased locally.

** For repair or service to motors, always give the motor model number.

REPAIR PARTS

Tank Only – Model 390.2521

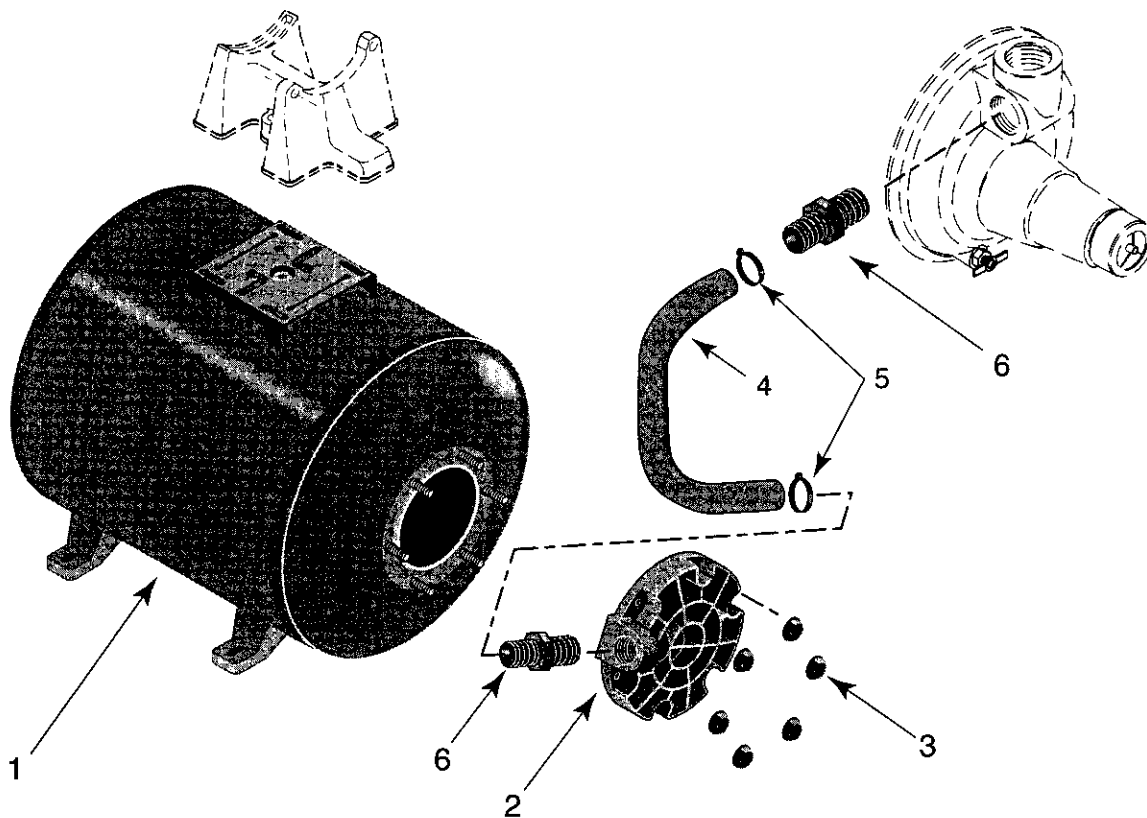

To Order Parts in the U.S.A., Call
Sears Product Service, 1-800-366-7278

To Order Parts outside the U.S.A., Call
Your local Sears Service Center or Store

REPAIR PARTS

Key No.	Model 390.2521 1/2 HP Part Number	Qty. Used	Description
1	29135	1	Tank Assembly (Includes Diaphragm, Elbow, Valve, Nuts, Washers, & Inlet Flange)
•	U20-13	1	Bag - Vinyl
•†	—	1	Air Valve w/Cap
2	U31-446P	1	Inlet Flange
3†	—	6	Nut - 5/16-18 Hex
4	U74-37H	1	Hose - 1" x 24-1/2"
5	U19-55SS	2	Clamp
6†	—	2	Adapter - 1" NPT (Male) x 1" Insert

• Not illustrated.

† Standard hardware item, may be purchased locally.

SEARS

OWNER'S MANUAL

Model No.
390.2521

The model number of your Shallow Well Water System will be found on the pump body.

When requesting service or ordering parts, always give the following information:

- Product Type
- Model Number
- Part Number
- Part Description

CRAFTSMAN[®] PROFESSIONAL 1/2 HP SHALLOW WELL WATER SYSTEM

For the repair or replacement parts you need

Call 7 am - 7 pm, 7 days a week

1-800-366-PART

(1-800-366-7278)

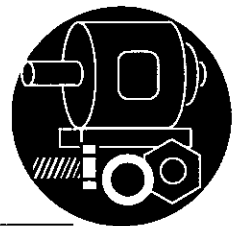

For in-home major brand repair service

Call 24 hours a day, 7 days a week

1-800-4-REPAIR

(1-800-473-7247)



For the location of a
Sears Repair Service Center in your area

Call 24 hours a day, 7 days a week

1-800-488-1222



For information on purchasing a Sears
Maintenance Agreement or to inquire
about an existing Agreement

call 9 am - 5 pm, Monday-Saturday

1-800-827-6655



SEARS

REPAIR SERVICES

America's Repair Specialists

Sears, Roebuck and Co., Hoffman Estates, IL 60179 U.S.A.