



Installation Instructions & Owner's Manual

Sanitizer Plus Series®

Water Conditioners



TABLE OF CONTENTS

Preinstallation Instructions for Dealers	3
Bypass Valve	3-4
Installation	5-6
Programming Procedures	7-8
Operating Displays and Instructions	8-10
Start-up Instructions	11
Troubleshooting Guide	12-13
Replacement Parts	14-22
Specifications	23
Quick Reference Guide	24

YOUR WATER TEST

Hardness _____ gpg
Iron _____ ppm
pH _____ number
*Nitrates _____ ppm
Manganese _____ ppm
Sulphur _____ yes/no
Total Dissolved Solids _____

*Over 10 ppm may be harmful for human consumption. Water conditioners do not remove nitrates or coliform bacteria, this requires specialized equipment.

Your Sanitizer Series water conditioners are precision built, high quality products. These units will deliver conditioned water for many years to come, when installed and operated properly. Please study this manual carefully and understand the cautions and notes before installing. This manual should be kept for future reference. If you have any questions regarding your water conditioner, contact your local dealer or Water-Right at the following:

Water-Right, Inc.
1900 Prospect Court • Appleton, WI 54914
Phone: 920-739-9401 • Fax: 920-739-9406

PREINSTALLATION INSTRUCTIONS FOR DEALERS:

The manufacturer has preset the water treatment unit's sequence of cycles, cycle times, salt dose, exchange capacity and salt dose refill time.

The dealer should read this page and guide the installer regarding hardness, day override, and time of regeneration, before installation:

For the installer, the following must be used:

- Program Installer Settings ... Hardness, Day Override (preset to 6 days), and Time of Regeneration (preset to 2 a.m., with brine tank refill to occur four hours prior; see Operating Displays and Instructions for more details)
- Read Normal Operating Displays
- Set Time of Day
- Read Power Loss & Error Display

For the homeowner, please read operating displays and instructions.

WATER SOFTENERS:

During operation, the normal user display is *time of day* and *gallons per minute*.

Flow Rate, *Capacity Remaining* and *Days to a Regeneration* are optional displays but are not normally used. Each of these can be viewed by pressing **NEXT** to scroll through them. When stepping through any programming, if no buttons are pressed within 5 minutes, the display returns to a normal user display. Any changes made prior to the 5 minute time out are incorporated.

To quickly exit any Programming, Installer Settings, etc., press **SET CLOCK**. Any changes made prior to the exit are incorporated. If desired, two regenerations within 24 hours are possible with a return to the preset program. To do a *double regeneration*:

1. Press the **REGEN** button once. "REGEN TODAY" will flash on the display.
2. Press and hold the **REGEN** button for three seconds until a regeneration begins.

Once the valve has completed the immediate regeneration, the valve will regenerate one more time at the preset.

BYPASS VALVE:

The bypass valve is typically used to isolate the control valve from the plumbing system's water pressure in order to perform control valve repairs or maintenance. The 1" full flow bypass valve incorporates four positions, including a diagnostic position that allows a service technician to have pressure to test a system while providing untreated bypass water to the building. Be sure to install bypass valve onto main control valve, before beginning plumbing. Or, make provisions in the plumbing system for a bypass. The bypass body and rotors are glass-filled Noryl® and the nuts and caps are glass-filled polypropylene. All seals are self-lubricating EPDM to help prevent valve seizing after long periods of non-use. Internal "O" Rings can easily be replaced if service is required.

The bypass consists of two interchangeable plug valves that are operated independently by red arrow shaped handles. The handles identify the direction of flow. The plug valves enable the bypass valve to operate in four positions.

1. **NORMAL OPERATION POSITION:** The inlet and outlet handles point in the direction of flow indicated by the engraved arrows on the control valve. Water flows through the control valve for normal operation of a water softener. During the regeneration cycle this position provides regeneration water to the unit, while also providing untreated water to the distribution system (**Fig. 1**).
2. **BYPASS POSITION:** The inlet and outlet handles point to the center of the bypass. The system is isolated from the water pressure in the plumbing system. Untreated water is supplied to the building (**Fig. 2**).
3. **DIAGNOSTIC POSITION:** The inlet handle points toward the control valve and the outlet handle points to the center of bypass valve. Untreated supply water is allowed to flow to the system and to the building, while not allowing water to exit from the system to the building (**Fig. 3**). This allows the service technician to draw brine and perform other tests without the test water going to the building.
NOTE: The system must be rinsed before returning the bypass valve to the normal position.
4. **SHUT OFF POSITION:** The inlet handle points to the center of the bypass valve and the outlet handle points away from the control valve. The water is shut off to the building. The water treatment system will depressurize upon opening a tap in the building. A negative pressure in the building combined with the softener being in regeneration could cause a siphoning of brine into the building. If water is available on the outlet side of the softener, it is an indication of water bypassing the system (**Fig. 4**) (i.e. a plumbing cross-connection somewhere in the building).

NORMAL OPERATION POSITION

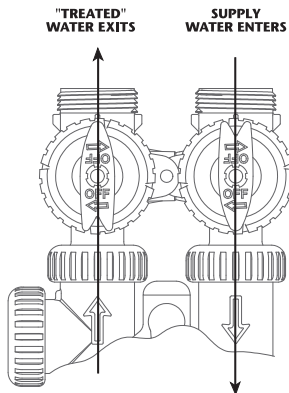

Figure 1

BYPASS POSITION

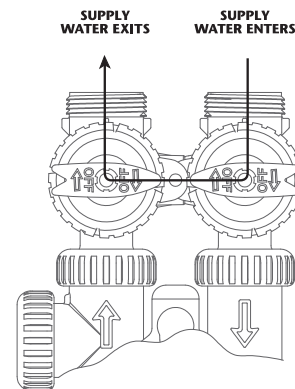

Figure 2

DIAGNOSTIC POSITION

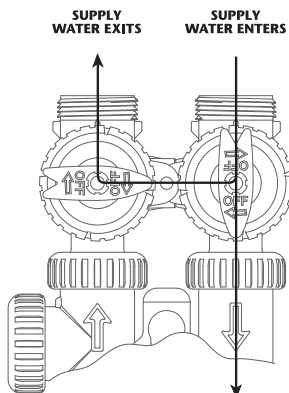

Figure 3

SHUT OFF POSITION

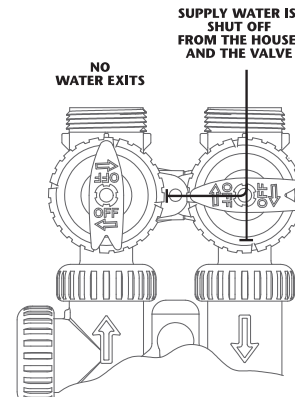

Figure 4

INSTALLATION:

GENERAL INSTALLATION & SERVICE WARNINGS

The control valve, fittings and/or bypass are designed to accommodate minor plumbing misalignments. There is a small amount of "give" to properly connect the piping, but the water softener is not designed to support the weight of the plumbing.

Do not use Vaseline, oils, other hydrocarbon lubricants or spray silicone anywhere. A silicone lubricant may be used on black "O" Rings, but is not necessary. *Avoid any type of lubricants, including silicone, on red or clear lip seals.*

Do not use pipe dope or other sealants on threads. Teflon® tape must be used on the threads of the 1" NPT inlet and outlet, the brine line connection at the control valve, and on the threads for the drain line connection. Teflon® tape is not used on the nut connections or caps because "O" Ring seals are used. The nuts and caps are designed to be unscrewed or tightened by hand or with the special plastic Service Wrench, #CV3193-01. If necessary pliers can be used to unscrew the nut or cap. Do not use a pipe wrench to tighten nuts or caps. *Do not place screwdriver in slots on caps and/or tap with a hammer.*

SITE REQUIREMENTS

- water pressure – 25-100 psi
- water temperature – 33-100°F (0.5-37.7°C)
- electrical – 115/120V, 60Hz uninterrupted outlet
- the tank should be on a firm level surface
- current draw is 0.5 amperes
- the plug-in transformer is for dry locations only

WELL WATER INSTALLATION

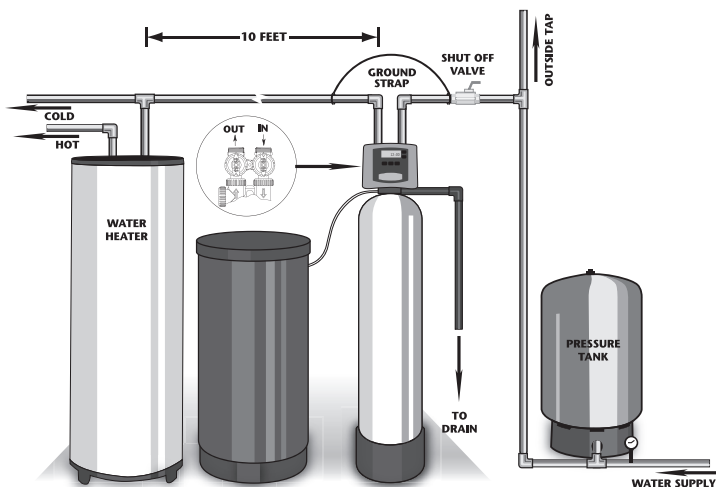

MUNICIPAL INSTALLATION

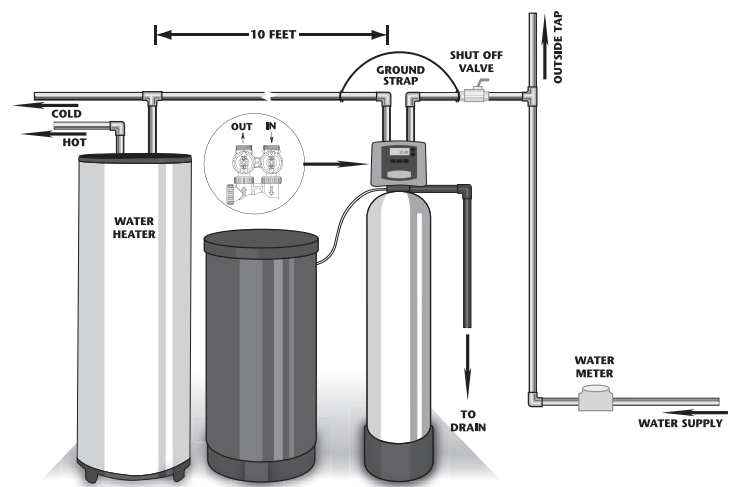

1. The distance between the drain and the water conditioner should be as short as possible.
2. Since salt must be periodically added to the brine tank, it should be located where it is easily accessible.
3. Do not install any water conditioner with less than 10 feet of piping between its outlet and the inlet of a water heater.
4. Do not locate unit where it or its connections (including the drain and overflow lines) will ever be subjected to room temperatures under 33°F.

6. **INLET/OUTLET PLUMBING:** Be sure to install Bypass Valve onto main control valve before beginning plumbing. Make provisions to bypass outside hydrant and cold hard water lines at this time. Install an inlet shutoff valve and plumb to the unit's bypass valve inlet located at the right rear as you face the unit. There are a variety of installation fittings available. They are listed under Installation Fitting Assemblies, page 21-22. When assembling the installation fitting package (inlet and outlet), connect the fitting to the plumbing system first and then attach the nut, split ring and "O" Ring. Heat from soldering or solvent cements may damage the nut, split ring or "O" Ring. Solder joints should be cool and solvent cements should be set before installing the nut, split ring and "O" Ring. Avoid getting solder flux, primer, and solvent cement on any part of the "O" Rings, split rings, bypass valve or control valve. If the building's electrical system is grounded to the plumbing, install a copper grounding strap from the inlet to the outlet pipe. Plumbing must be done in accordance with all applicable local codes.

7. **DRAIN LINE:** First, be sure that the drain can handle the backwash rate of the system. Solder joints near the drain must be done prior to connecting the drain line flow control fitting. Leave at least 6" between the drain line flow control fitting and solder joints. Failure to do this could cause interior damage to the flow control. Install a 1/2" I.D. flexible plastic tube to the Drain Line Assembly or discard the tubing nut and use the 3/4" NPT fitting for rigid pipe (recommended). **If the backwash rate is greater than 7 gpm, use a 3/4" rigid drain line.** Where the drain line is elevated but empties into a drain below the level of the control valve, form a 7" loop at the discharge end of the line so that the bottom of the loop is level with the drain connection on the control valve. This will provide an adequate anti-siphon trap. Piping the drain line overhead <10 ft is normally not a problem. Be sure adequate pressure is available (40-60 psi is recommended). Where the drain empties into an overhead sewer line, a sink-type trap must be used. Run drain tube to its discharge point in accordance with plumbing codes. Pay special attention to codes for air gaps and anti-siphon devices.
NOTE: Drain line nut will not be supplied for units having a backwash rate greater than 7 gpm.

8. **BRINE TANK CONNECTION:** Install the 3/8" O.D. polyethylene tube from the Refill Elbow to the Brine Valve in the brine tank.

9. **OVERFLOW LINE CONNECTION:** *An overflow drain line is recommended where a brine overflow could damage furnishings or the building structure.* Your softener is equipped with a brine tank safety float which greatly reduces the chance of an accidental brine overflow. In the event of a malfunction, however, an *overflow line connection* will direct the "overflow" to the drain instead of spilling on the floor where it could cause considerable damage. This fitting is an elbow on the side of the brine tank. Attach a length of 1/2" I.D. tubing to fitting and run to drain. Do not elevate overflow line higher than 3" below bottom of overflow fitting. Do not "tie" this tube into the drain line of the control valve. Overflow line must be a direct, separate line from overflow fitting to drain, sewer, or tub. Allow an air gap as per the drain line instructions.



CAUTION: Never insert a drain line into a drain, sewer line, or trap. Always allow an air gap between the drain line and the wastewater to prevent the possibility of sewage being back-siphoned into the conditioner.

PROGRAMMING PROCEDURES:

1. Set time of day:

Time of day should only need to be set after extended power outages or when daylight saving time begins or ends. If an extended power outage occurs, the time of day will flash on and off indicating that the time should be reset.

STEP 1 – Press **SET CLOCK**.

STEP 2 – **CURRENT TIME (HOUR)**: Set the hour of the day using **+** or **-** buttons. AM/PM toggles after 12. Press **NEXT** to go to step 3.

STEP 3 – **CURRENT TIME (MINUTES)**: Set the minutes using **+** or **-** buttons. If it is desired to back up to the previous step press **REGEN** button once. Press **NEXT** to go to step 4.

STEP 4 – **CURRENT DAY**: Set the day of the week using **+** or **-** buttons. Pressing **NEXT** will exit **SET CLOCK** and return to the general operating display (page 10).

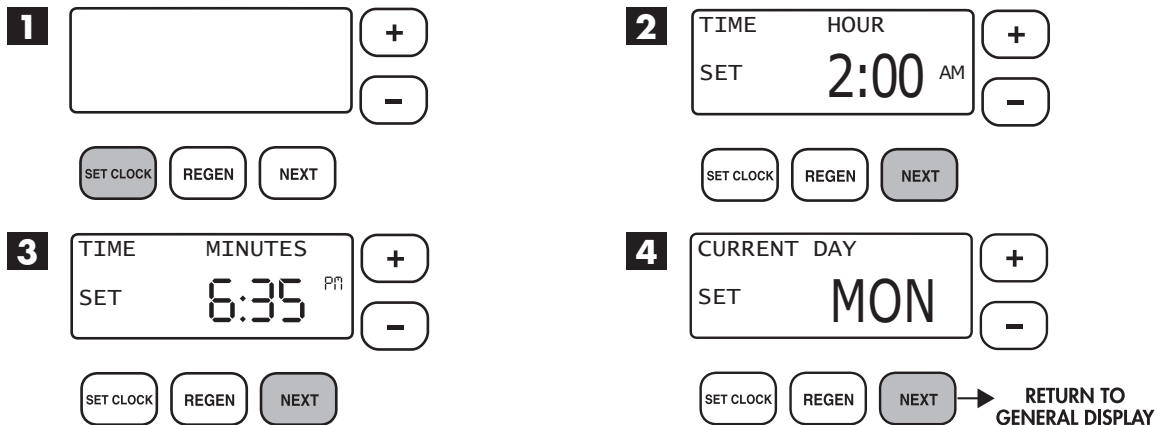

2. Programming:

NOTE: The manufacturer has preset the unit so that the gallons between regenerations will be automatically calculated after the hardness is entered.

STEP 1 – Press **NEXT** and **+** simultaneously for 3 seconds.

STEP 2 – **HARDNESS**: Set the amount of hardness in grains per gallon (default 20) using the **+** or **-** buttons. The allowable range is from 1 to 150 in 1 grain increments.

Note: If a resin media is used in the softener, increase the grains per gallon if soluble iron is present (1ppm = 4 gpg). This display will show “-nA- (not available)” if “FILTER” is selected or if “AUTO” is not factory set.

Press **NEXT** to go to step 3. Press **REGEN** if you want to exit.

STEP 3 – **DAYS BETWEEN REGENERATION (DAY OVERRIDE)**: The manufacturer has factory set 6 DAYS as the default. This is the maximum number of days between regenerations. If this is set to “OFF”, regeneration initiation is based solely on gallons used. If any number is set (allowable range from 1 to 28), a regeneration initiation will be called for on that day even if a sufficient number of gallons were not used to call for a regeneration.

Set Day Override using **+** or **-** buttons (6 is recommended):

- set number of days between regeneration (1 to 28); or
- set to “OFF”

NOTE: This valve has the capability of regenerating up to six times in one day. This can be observed by using the **-** button to toggle below once a day regeneration (see example to right). These settings are typically used in twin system configurations or in commercial settings.

Press **NEXT** to go to step 4. Press **REGEN** if you need to return to the previous step.

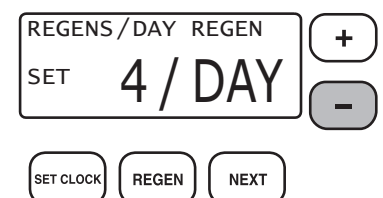

Example: Indicates unit set to regen 4 times in one day.

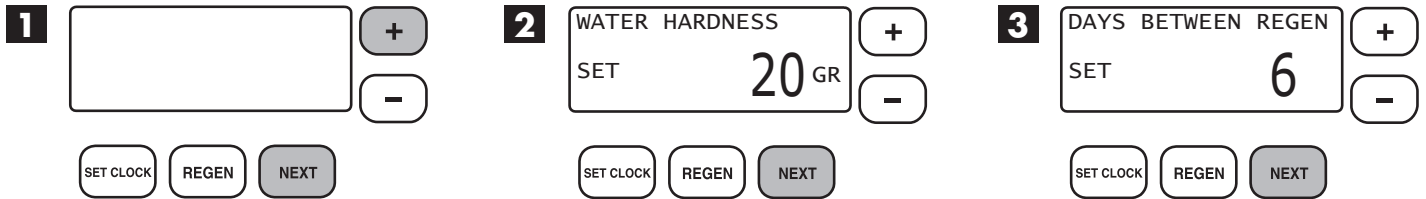

STEP 4 – REGENERATION HOUR: The manufacturer has factory set 2:00 A.M. as the default. This is the hour of day for regeneration and can be reset by using **+** or **-** buttons. “AM/PM” toggles after 12. The default time is 2:00 a.m. (recommended for a normal household). Press **NEXT** to go to step 5. Press **REGEN** if you need to return to the previous step.

STEP 5 – REGENERATION MINUTES: Set the minutes using **+** or **-** buttons. Press **NEXT** to go to step 6. Press **REGEN** to return to previous step. To initiate an immediate manual regeneration, press and hold the **REGEN** button for three seconds. The system will begin to regenerate immediately. The control may be manually stepped through the regeneration cycles by pressing **REGEN**.

STEP 6 – ALARM BUZZER: The manufacturer has factory set ON as the default. Alarm will sound immediately after regeneration if there is no salt or if another error has occurred. Turn the alarm OFF or ON using **+** or **-** buttons. Press **NEXT** to exit installer programming.

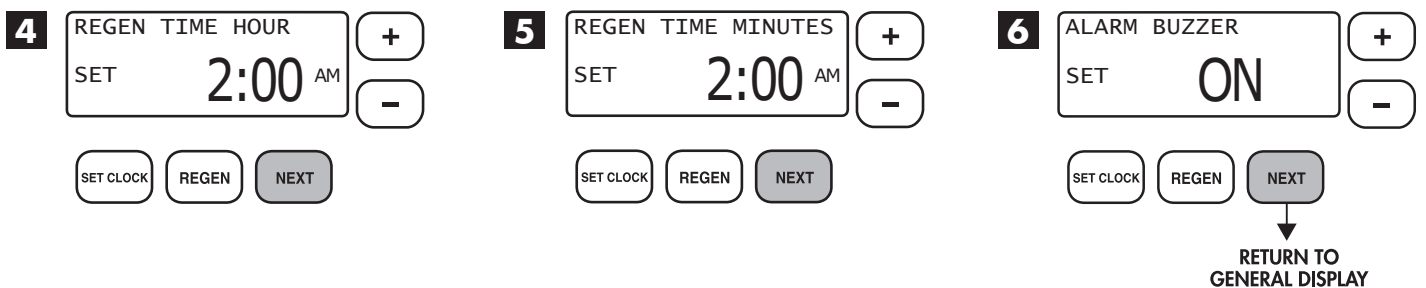

OPERATING DISPLAYS AND INSTRUCTIONS:

1. **GENERAL OPERATION:** When the system is operating, one of four displays may be shown. Pressing **NEXT** will alternate between the displays.

1. *CURRENT TIME OF DAY* and *GPM*
2. *FLOW RATE* which is the current treated water flow rate through the system in Gallons Per Minute
3. *CAPACITY REMAINING* which is the gallons that will be treated before the system signals a regeneration cycle
4. *DAYS TO A REGEN* is the number of days left before the system goes through a regeneration cycle, based on the days override value

The user can scroll between the displays as desired.

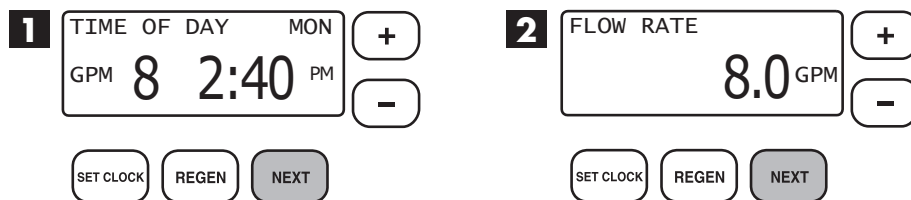

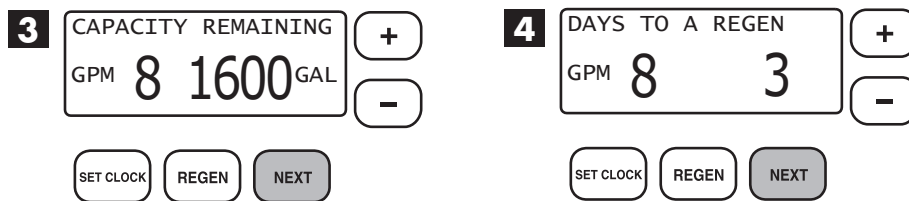

If the system has called for a regeneration that will occur at the preset time of regeneration, the words "REGEN TODAY" will appear on the display.

If a water meter is installed, "GPM" flashes on the display when water is being treated, indicating gallons per minute going through the system.

2. **REGENERATION MODE:** Typically a system is set to regenerate at a time of no water usage. If there is a demand for water when the system is regenerating, untreated water will be delivered. When the system begins to regenerate, the display will change to include information about the step of the regeneration process and the time remaining for that step to be completed. The system runs through the steps automatically and will reset itself to provide treated water when the regeneration has been completed.

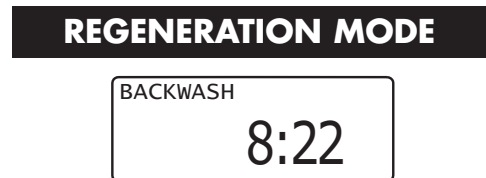

3. **MANUAL REGENERATION:** Sometimes there is a need to regenerate before the control valve calls for it. This may be needed if a period of heavy water use is anticipated or when the system has been operated without salt.

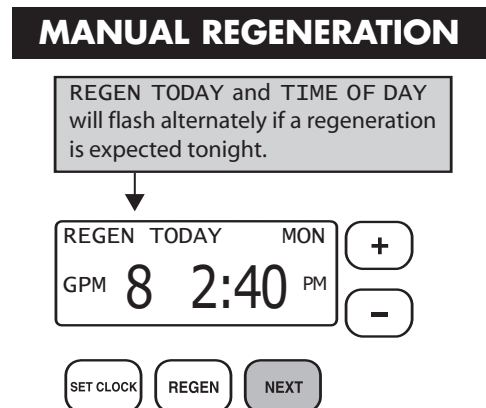

- To initiate a manual regeneration *at the next preset regeneration time*, press and release **REGEN**. The words "REGEN TODAY" will flash on the display to indicate that the system will regenerate at the next regeneration time (set in Programming, steps 4 and 5). *If you pressed the REGEN button in error, pressing the button again will cancel the command.*
- To initiate a manual regeneration *immediately*, press and hold the **REGEN** button for three seconds. The system will begin to regenerate immediately. **This command cannot be cancelled.**

Once a manual regeneration is initiated, the unit will go into the FILL position. This position allows water to enter the brine tank until it reaches the proper level. Once this position is complete, you will notice a 240 Minute (4 hours) SOFTENING position. This 4-hour window allows the salt to dissolve and achieve proper brine strength. During these FILL and SOFTENING positions, you will have softened water available for use. Once the unit advances to the BACKWASH position and subsequent positions thereafter (see Start Up Instructions for regeneration sequence), the water softener will deliver water, but it will be untreated.

IMPORTANT: With the Dry Salt Storage Feature, the brine tank will refill 4 hours before the actual regeneration occurs. You may experience a small amount of noise for a short period of time at 10:00 p.m. (with typical setting) on the night that regeneration is to occur. This noise is only the brine tank filling and at no time during this process will you be without treated water.

4. **POWER LOSS AND BATTERY REPLACEMENT:**

The AC transformer comes with a 15 foot power cord and is designed for use with the control valve; the transformer should only be used in a dry location.

In the event of a power outage, the control valve will remember all settings and time of day. If an extended power outage occurs, the control valve will keep time of day until the battery is depleted. When the battery becomes depleted, the only item that needs to be reset is the time of day and will be indicated by the time of day flashing. All other settings are permanently stored in the nonvolatile memory.

If a power loss occurs and the time of day flashes, this indicates that the battery is depleted. The time of day should be reset and the non-rechargeable battery should be replaced. The battery is a 3 Volt Lithium Coin Cell type 2032 and is readily available at most stores. To access battery location, remove front cover (see diagram on page 14 for battery location).

BATTERY REPLACEMENT

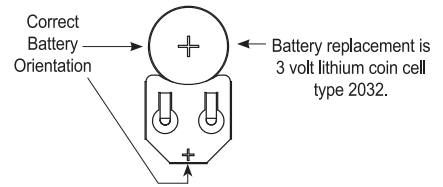

When replacing the battery, align positives and push down to fully seat.

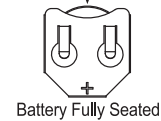

5. **CHECK SALT INDICATOR AND AUDIBLE ALARM:** This control valve is equipped with a Low Salt Warning to alert homeowners that the system is operating in a low salt condition. This usually indicates that the salt level in the brine tank is too low to operate properly. If "CHECK SALT" appears on the screen, there will usually be an audible alarm that sounds also (if turned on), alerting you to these conditions.

To turn off alarm: If the audible alarm sounds due to a low salt condition, press any button on the face of the control valve to turn off. If salt is not added to the brine tank before the next regeneration, the CHECK SALT indicator will alarm again.

IMPORTANT: If you feel that the salt level is adequate (at least 1/3 full) in the brine tank, please contact the dealer that installed your system for service.

6. **ERROR MESSAGE:** If the word "ERROR" and a number are alternately flashing on the display record the number and contact your dealer for help. This indicates that the control valve was not able to function properly.

ERROR

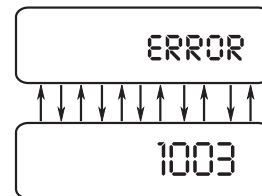

7. **BRINE TANK MAINTENANCE AND SALT:** Refill the brine tank as necessary, making sure at least 1/3 of the brine tank is full at all times. Without proper salt levels, the water softener may not operate properly.

Because "typical" settings of this water softener include a dry salt storage feature (no water in brine tank between regeneration), the manufacturer recommends the use of solar salt for best results. The brine tank is manufactured for the use of solar, pellets or rock salt. **Do not use block salt.** If pellet or rock salt is used, a cleaning of the brine tank every six months is recommended. If the dry salt storage feature is not being utilized, block salt may be used.



CAUTION: Do not use any resin cleaners, nor place any resin cleaners into the brine tank. Furthermore, do not use any salt that indicates it is an iron cleaning salt or that contains any cleaning additives. This may be harmful to the water softener and for human consumption. Consult dealer for proper cleaning instructions.

START-UP INSTRUCTIONS:

- After installation is complete, rotate bypass handles to bypass mode (*see Fig.2 on page 4*).
- Turn on water and check for leaks.
- Fully open a cold water faucet — preferably a laundry sink or bathtub without an aerator.
- Allow water to run until clear to rid pipes of debris which may have occurred during installation.

System regeneration sequence is in the following order. (If it is desired to change this sequence, please refer to the Dealer Manual or contact the manufacturer.)

- 1) BRINE TANK REFILL**
- 2) 4 HOURS (240 minutes) OF SOFTENING MODE WHILE SALT IS DISSOLVING**
- 3) BACKWASH**
- 4) BRINE DRAW AND SLOW RINSE**
- 5) FAST RINSE**
- 6) END (return to service)**

The system is now ready for filling with water and for testing.

1. With the softener in the bypass mode (*Fig. 2 on page 4*) and the control valve in normal operation where the display shows either the time of day or the gallons remaining, manually add 3" of water to the regenerant tank.

NOTE: If too much water is put into the brine tank during softener start up, it could result in a "salty water" complaint after the first regeneration.

During the first regeneration the unit will draw out the initial volume of brine/regenerant and refill it with the correct preset amount.

2. With the softener in bypass mode, press and hold the **REGEN** button until the motor starts. Release button. The display reads "FILL" and the remaining time in this step is counting down. Since the regenerant tank was already filled in Step 1 press **REGEN** again and the display will read SOFTENING 240 (During a full regeneration this will be a 4 hour period for salt to dissolve). Press **REGEN** again to put the valve into "BACKWASH." Once valve has stopped in position, unplug the transformer so that the valve will not cycle to the next position. Open the inlet handle of the bypass valve very slightly allowing water to fill the tank slowly in order to expel air.



CAUTION: If water flows too rapidly, there will be a loss of media to the drain.

3. When the water is flowing steadily to the drain without the presence of air, slowly open the inlet valve. Restore power and momentarily press the **REGEN** button to advance the control to the "BRINE" position.
4. The bypass is now in the diagnostic mode (*Fig. 3 on page 4*). Check to verify that water is being drawn from regenerant tank with no air leaks or bubbles in the brine line. There should be a slow flow to the drain.
5. Momentarily press **REGEN** again until the display reads "RINSE." There should be a rapid flow to the drain. Unplug transformer to keep the valve in the "RINSE" position. Allow to run until steady, clear and without air. While the unit is rinsing load the brine tank with water softener salt. Restore power.
6. Place bypass valve in the normal operating mode (*Fig. 1 on page 4*) by opening the outlet bypass handle. Press **REGEN** and the unit will return to the service position with time of day being displayed.

TROUBLESHOOTING GUIDE:

PROBLEM	CAUSE	CORRECTION
Timer does not display time of day	A. transformer unplugged	A. reconnect transformer
	B. no power at outlet	B. repair or use working outlet
	C. defective transformer	C. replace transformer
	D. defective PC board	D. replace PC board
Timer does not display correct time of day or time of day flashes	A. outlet is on a switch	A. use unswitched outlet
	B. power outage; transformer was unplugged from either wall outlet or from PC board	B. reset time of day and replace battery (see instructions on page 12)
	C. defective PC board	C. replace PC board
"Check Salt" appears on yellow screen with audible alarm	A. low salt in brine tank	A. push any button on cover to stop alarm and add salt to brine tank
	B. plugged injector and/or injector screen	B. clean or replace injector and screen
	C. drain line plugged or restricted	C. clear drain line restriction
	D. chlorine generator probes are dirty	D. clean or replace chlorine generator
	E. system drawing in air	E. tighten fittings in brine system
	F. system "short brining"	F. clean brine line flow control, check for bridging or hardened salt around brine well, increase brine refill time
No softening display when water is flowing	A. bypass valve in bypass position	A. put bypass in service position
	B. meter cable disconnected	B. reconnect PC board
	C. restricted/stalled meter turbine	C. remove meter and check for debris
	D. defective meter	D. replace meter
	E. defective PC board	E. replace PC board
Unit regenerates at wrong time of day	A. past power outage	A. reset time of day
	B. incorrect time of day displayed	B. reset time of day
	C. time of regenerant set incorrectly	C. reset time of regeneration
	D. control set at "on 0"	D. check with regeneration time option in programming
	E. control set at "NORMAL + on 0"	E. check with regeneration time option in programming
Valve stalled in regeneration (cont'd next page)	A. motor not operating	A. replace motors
	B. no power at outlet	B. repair outlet or use working outlet
	C. defective transformer	C. replace transformer

PROBLEM	CAUSE	CORRECTION
Valve stalled in regeneration (cont'd)	D. defective PC board	D. replace PC board
	E. broken drive gear or drive cap assembly	E. replace gear or drive cap assembly
	F. broken piston retainer	F. replace drive cap assembly
	G. broken main or regenerant piston	G. replace main or regenerant piston
Valve does not regenerate automatically when REGEN button is pressed	A. transformer unplugged	A. connect transformer and PC board power
	B. no power at outlet	B. restore power
	C. broken drive gear or drive cap assembly	C. replace gear or drive cap assembly
	D. defective PC board	D. replace board
Valve does not regenerate automatically but does when REGEN button is pressed	A. bypass valve not in normal operating mode	A. see bypass diagrams on page 4
	B. meter disconnected	B. reconnect to PC board
	C. obstructed meter turbine	C. clear obstruction
	D. defective meter	D. replace meter
	E. programming error	E. review programming
	F. defective PC board	F. replace board
ERROR followed by code #		
Error code 101: unable to recognize start of regeneration Error code 102: unexpected stall Error code 103: motor ran too long Error code 104: motor ran too long Error code 109, 201, 402, 403, 404, 410: circuit board failure TWIN ALT SYSTEMS Error code 106: motor ran too long Error code 107: unexpected stall	A. valve has just been serviced (#101)	A. press NEXT and REGEN for 3 seconds or momentarily unplug power source from PC board
	B. motor gears not fully engaged — motor wires broken — failed motor (#101)	B. check motor wiring
	C. foreign material stuck in valve (#102)	C. check piston and spacer stack for obstruction
	D. excessive piston resistance (#102)	D. replace piston(s) and spacer stack assembly
	E. piston not in home position (#104)	E. press NEXT and REGEN or momentarily unplug PC board power
	F. center drive gear reflector dirty or damaged — missing or broken gear (#104)	F. replace or clean drive gear(s)
	G. drive bracket incorrectly aligned on backplate (#104)	G. reset drive bracket
	H. PC board is damaged or defective (#109, 201, 402, 403, 404, 410)	H. replace PC board
	I. PC board incorrectly aligned on drive bracket (#109, 201, 402, 403, 404, 410)	I. reset PC board onto drive bracket
If other codes appear, contact dealer.		

REPLACEMENT PARTS:

FRONT COVER AND DRIVE ASSEMBLY

Item No.	Part No.	Description	Qty.
1	CV3540S-A	Black cover	1
	CV3540-WS-A	Gray cover	1
2	CV3107-1	Motor	1
3	CV3106-1	Drive bracket & spring clip	1
4	CV3554WS	PC board, CC	1
5	CV3110	Drive gear, 12 x 36	3
6	CV3109	Drive gear cover	1
7	CV3002CC	Drive assembly, CC	-
	CV3526	Transformer, 110V-12V	1
	CV3543	<i>Optional</i> weather cover	1

NOTE: Battery Location

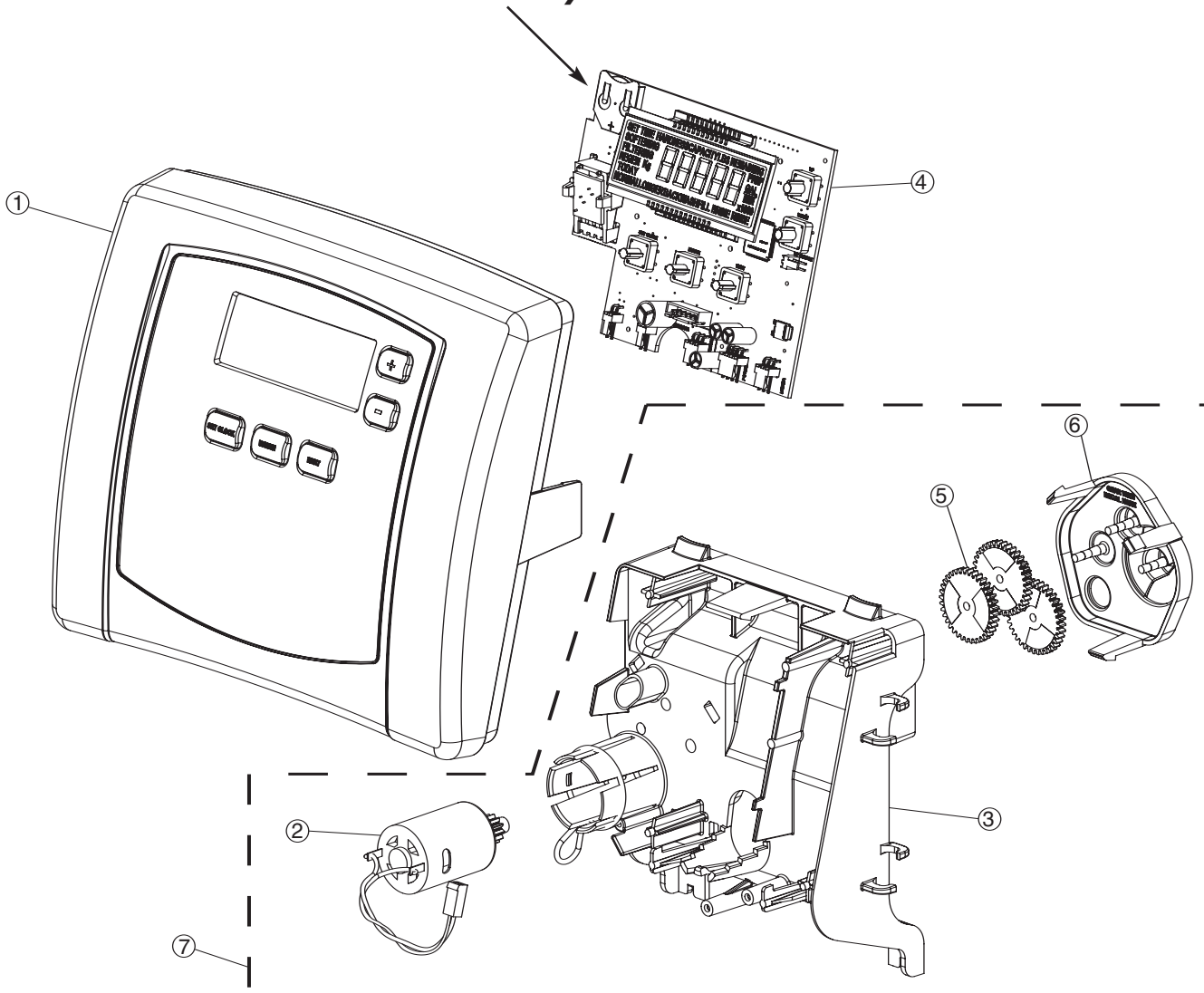

REPLACEMENT PARTS:

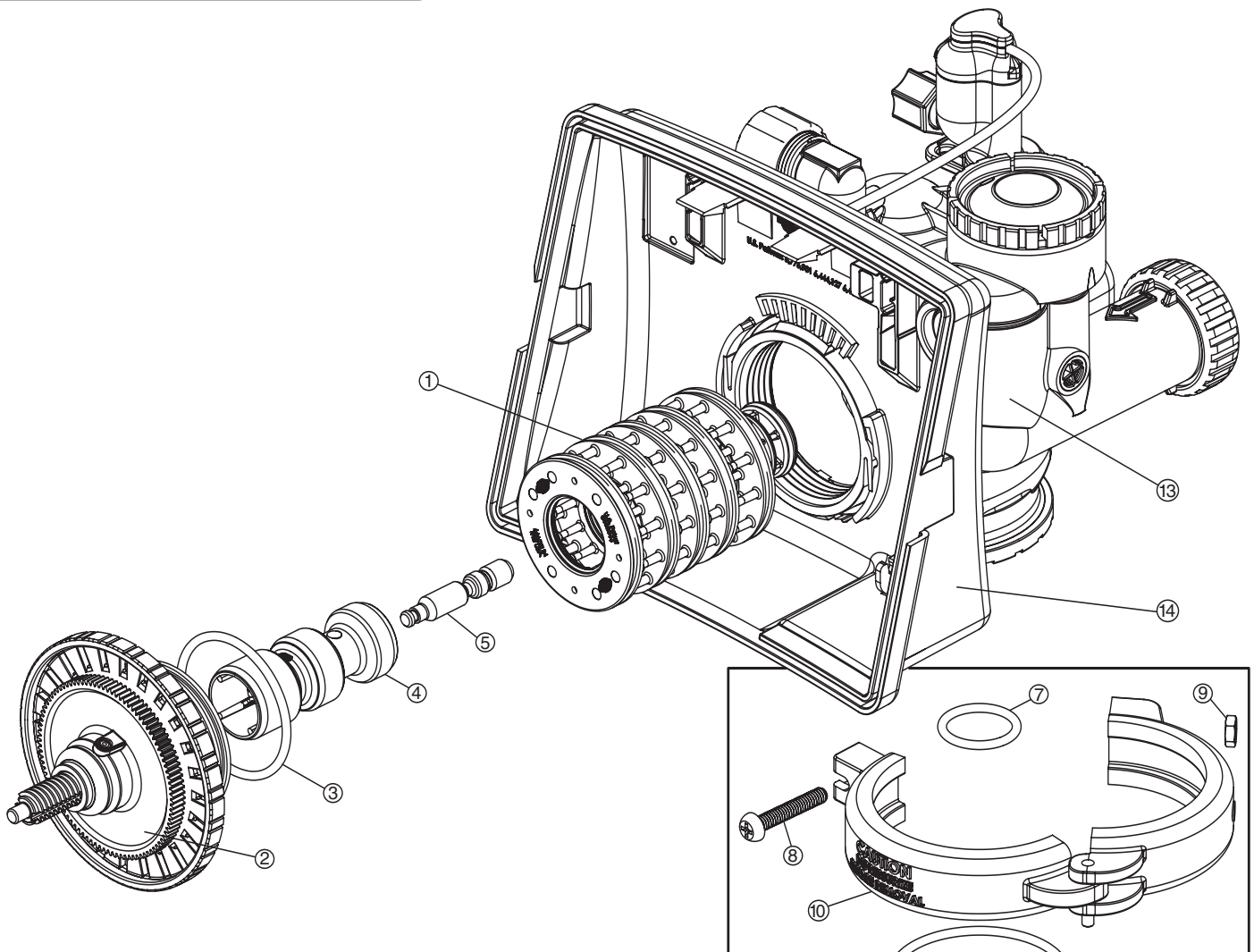

PISTON ASSEMBLY

Item No.	Part No.	Description	Qty.
1	CV3005	1" spacer stack assembly	1
	CV3430	1.25" spacer stack assembly	1
2	CV3004	Drive cap assembly	1
3	CV3135	O-ring 228	1
4	CV3011	1" piston assembly downflow	1
	CV3011-01	1" piston assembly upflow	1
	CV3407	1.25" piston assembly downflow	1
5	CV3174	Regenerant piston	1
6	CV3180	O-ring 337	1
7	CV3105	O-ring 215	1
8	CV3556	Screw, 1/4-20x1-1/2 18-8SS	1
9	CCI-00318337	Nut, 1/4-20 HEX 18-8SS	1
10	CV3016	QC2 clamp assembly (includes screw & nut)	1
11	CV3452	O-ring 230	1
12	CV3015	WS1 QC2 tank adapter assembly (includes O-rings)	1
13	CV3001	1" body assembly downflow	1
	CV3001UP	1" body assembly upflow	1
	CV3020	1.25" body assembly downflow	1
14	CV3541	Drive backplate	1

NOTE: Not available on 1 1/4" valve.

REPLACEMENT PARTS:

BYPASS VALVE			
Item No.	Part No.	Description	Qty.
1	CV3151	Nut, 1" quick connect	2
2	CV3150	Split ring	2
3	CV3105	O-ring 215	2
4	CV3145	Bypass rotor, 1"	2
5	CV3146	Bypass cap	2
6	CV3147	Bypass handle	2
7	CV3148	Bypass rotor seal retainer	2
8	CV3152	O-ring 135	2
9	CV3155	O-ring 112	2
10	CV3156	O-ring 214	2

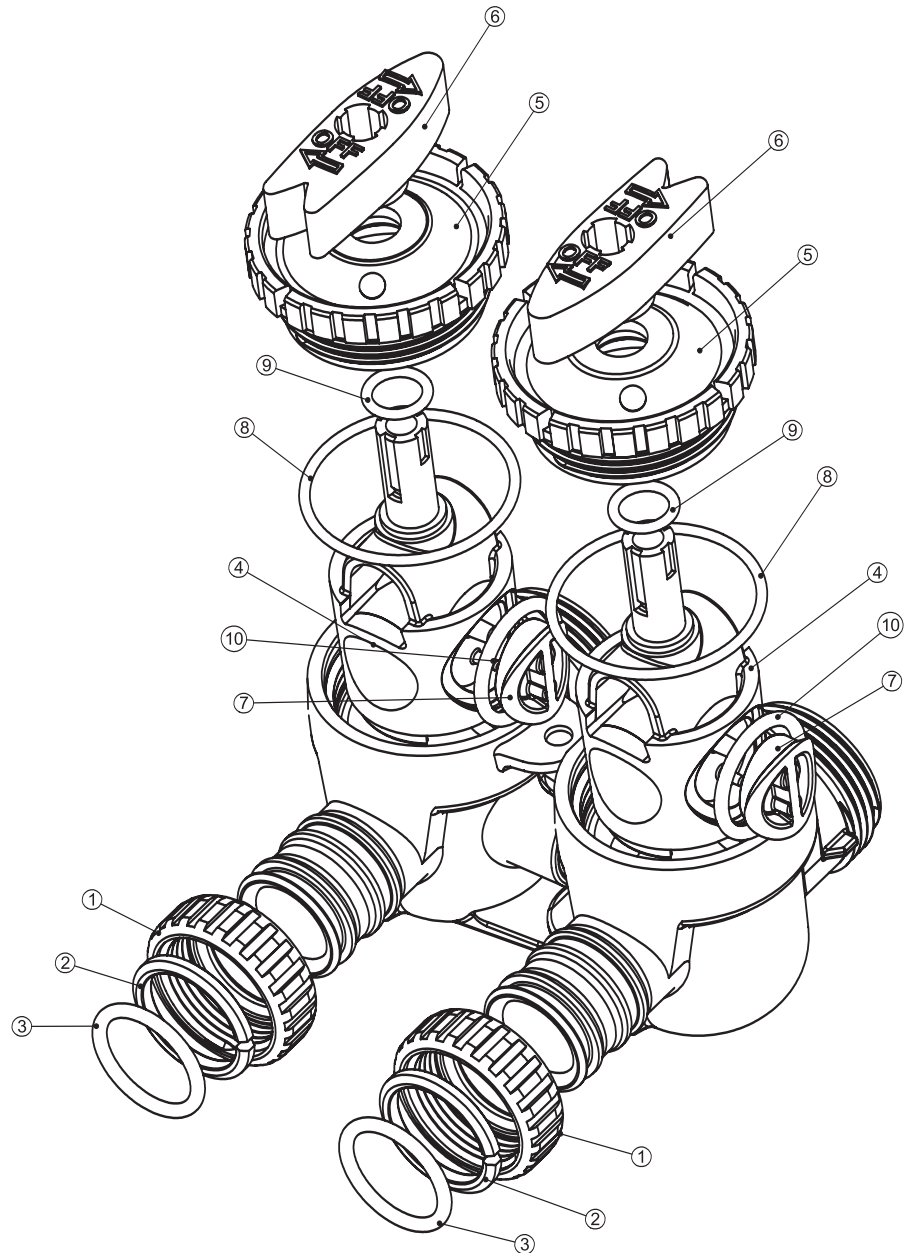

REPLACEMENT PARTS:

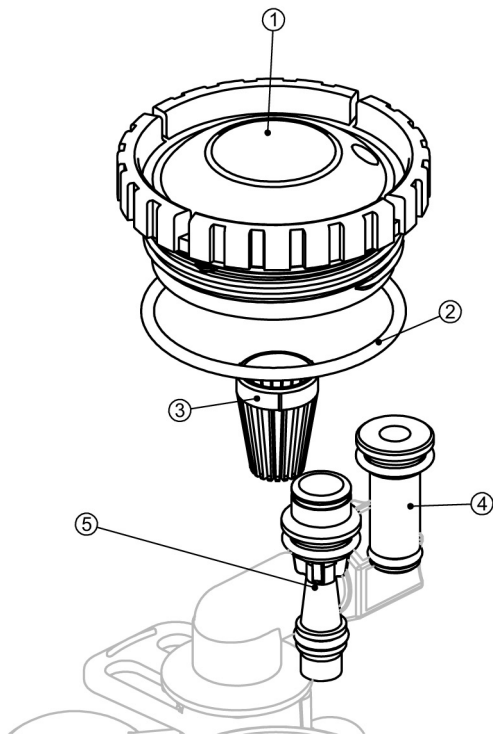

INJECTOR ASSEMBLIES			
Item No.	Part No.	Description	Qty.
1	CV3176	Injector cap	1
2	CV3152	O-ring 135	1
3	CV3177-01	Injector screen	1
4	CV3010-1Z	Injector assembly plug	1
5	CV3010-1A	A injector assembly, BLACK	1
	CV3010-1B	B injector assembly, BROWN	
	CV3010-1C	C injector assembly, VIOLET	
	CV3010-1D	D injector assembly, RED	
	CV3010-1E	E injector assembly, WHITE	
	CV3010-1F	F injector assembly, BLUE	
	CV3010-1G	G injector assembly, YELLOW	
	CV3010-1H	H injector assembly, GREEN	
	CV3010-1I	I injector assembly, ORANGE	
	CV3010-1J	J injector assembly, LIGHT BLUE	
CV3010-1K	K injector assembly, LIGHT GREEN		
not shown	CV3170	O-ring 011, lower	*
not shown	CV3171	O-ring 013, upper	*

* The injector plug and the injector each use one lower and one upper o-ring

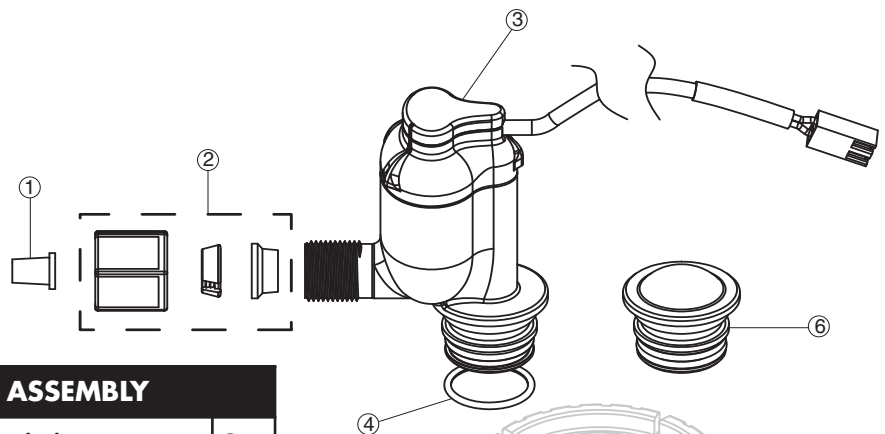

CHLORINE GENERATOR ASSEMBLY			
Item No.	Part No.	Description	Qty.
1	CS1197	Polytube 3/8" insert	1
2	JCPG-6PBLK	Nut compression, 3/8" black	1
3	CV3395	Chlorinator, NPT WR body assembly	1
4	CV3163	O-ring 019	1
5	CH4615	Locking clip	1
6	CV3195-01	Refill port plug assembly	1
ASSEMBLIES			
	CV3395-A	Complete chlorinator assembly	1

REPLACEMENT PARTS:

DRAIN LINE ASSEMBLY 3/4"			
Item No.	Part No.	Description	Qty.
1	CH4615	Elbow locking clip	1
2	CPKP10TS8-BULK	Optional insert, 5/8" tube	1
3	CV3192	Optional nut, 3/4" drain elbow	1
4	CV3158-01	Drain elbow, 3/4" NPT with O-ring	1
5	CV3163	O-ring 019	1
6	CV3159-01	DLFC retainer assembly	1
7	CV3162-007	0.7 DLFC for 3/4" elbow	1
	CV3162-010	1.0 DLFC for 3/4" elbow	
	CV3162-013	1.3 DLFC for 3/4" elbow	
	CV3162-017	1.7 DLFC for 3/4" elbow	
	CV3162-022	2.2 DLFC for 3/4" elbow	
	CV3162-027	2.7 DLFC for 3/4" elbow	
	CV3162-032	3.2 DLFC for 3/4" elbow	
	CV3162-042	4.2 DLFC for 3/4" elbow	
8	CV3331	Drain elbow and retainer assembly	

Items 2 and 3, nut and insert are only used with 1/2" I.D. by 5/8" O.D. polytubing. For other piping material, the 3/4" NPT is used.

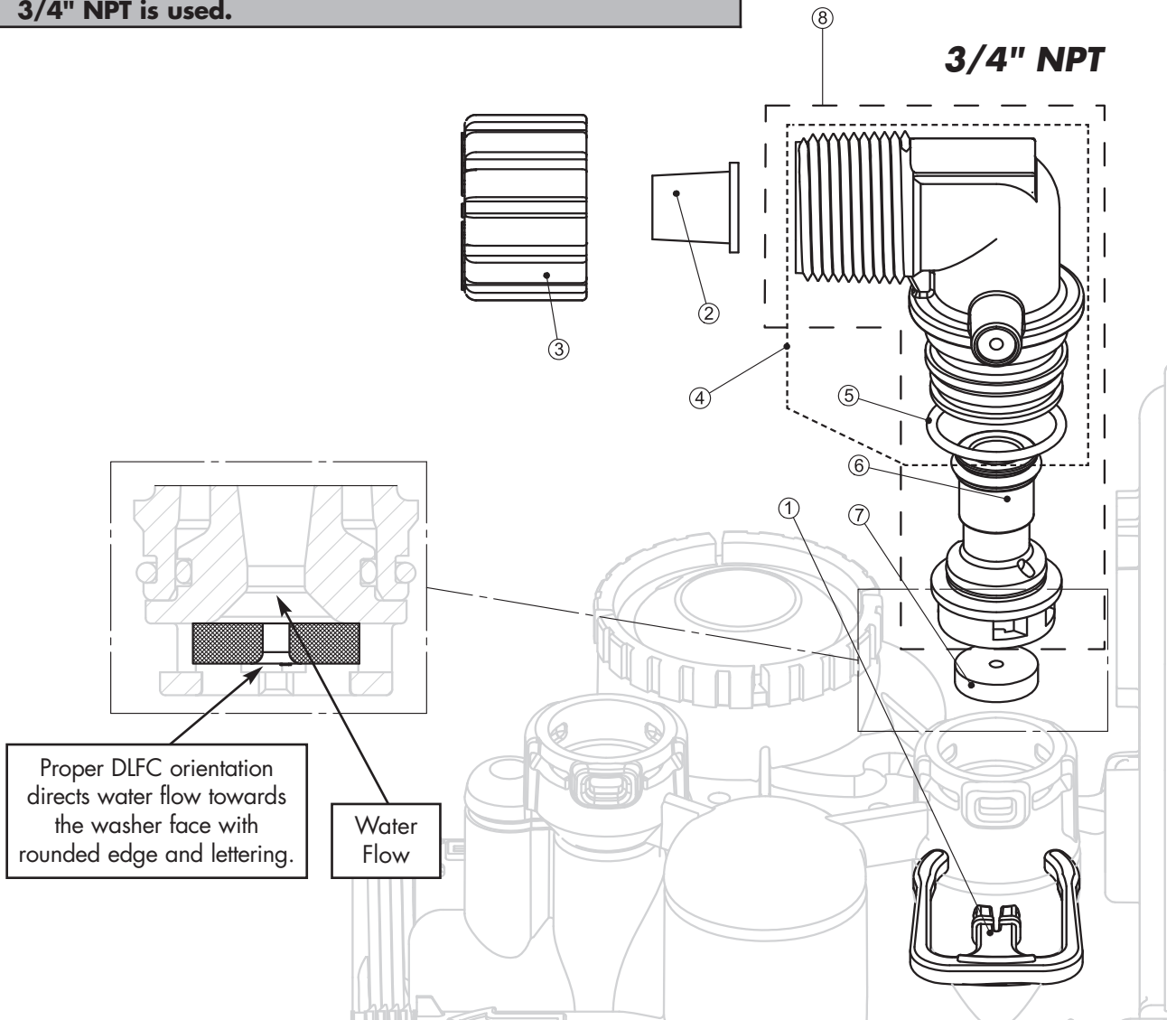

REPLACEMENT PARTS:

WATER METER & METER PLUG			
Item No.	Part No.	Description	Qty.
1	CV3151	Nut, 1" QC	1
2	CV3003	Meter assembly, includes items 3 & 4	1
3	CV3118-01	Turbine assembly	1
4	CV3105	O-ring 215	1
5	CV3003-01	Meter plug assembly	1
6	CV3013	<i>Optional</i> mixing valve	1

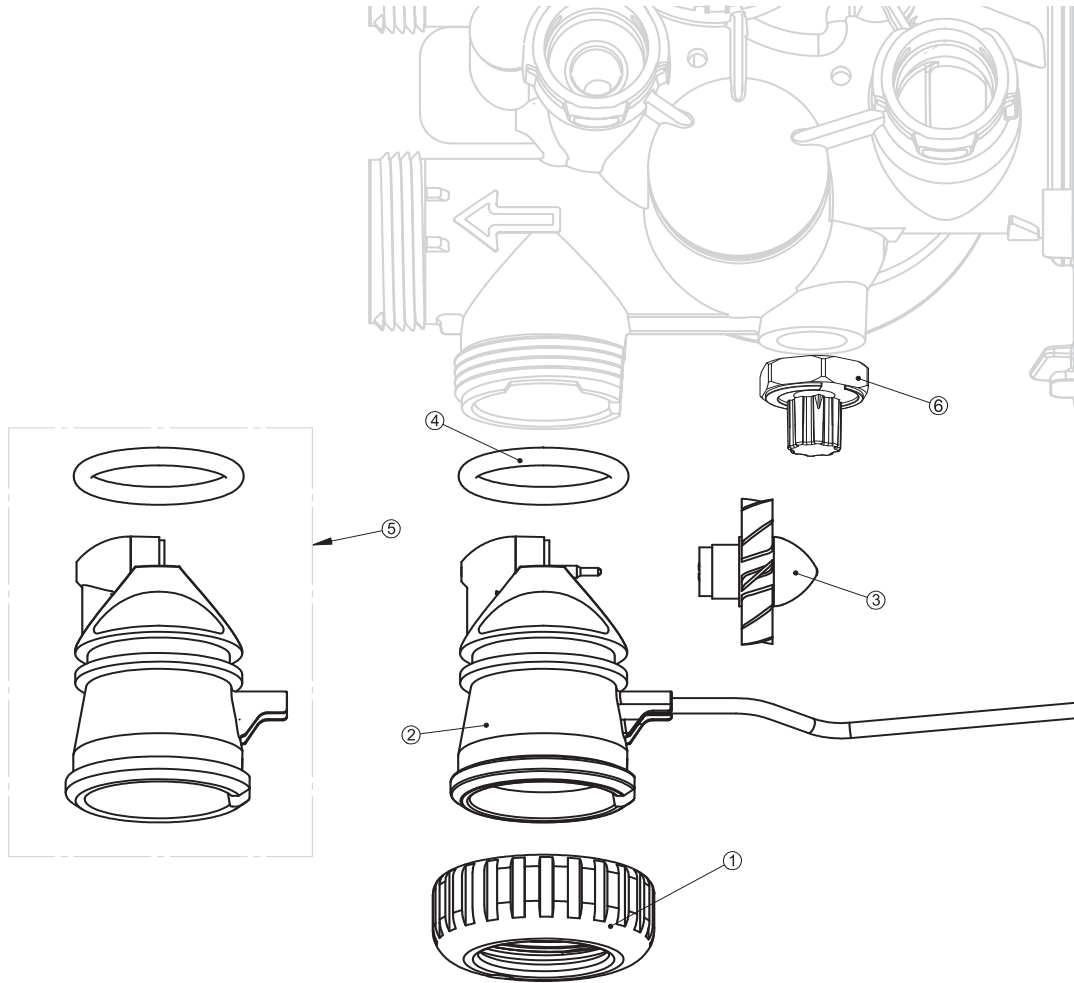

REPLACEMENT PARTS:

BRINE TANK ASSEMBLY

Item No.	Part No.	Description	Qty.
1	CG2191-84	Brine tank cover, injection molded WR	1
	CG2180	Brine tank cover, standard	1
2	CH1072-01	Optional 18" diameter salt grid	1
	CH1080	Optional 24" diameter salt grid	1
3	CG21833CB1C00	18" x 33" brine tank, black	1
	CG21840CB1C00	18" x 40" brine tank, black	1
	CG22441CB1C00	24" x 41" brine tank, black	1
4	CH1030-27	4" x 27" brine well (18 x 33 BT)	1
	CH1030-34.5	4" x 34.5" brine well (18 x 40, 24 x 40 BT's)	1
5	CH1018	2 piece overflow set	1
6	CH4500-48	474 air check assembly, 1/2" x 48"	1
7	CH4640-32	474 float assembly, 32" w/ 2 grommets	1
8	CH4600-50	474 safety brine valve w/ .5 gpm flow control	1
9	CH7016	Cap 4" brine well	1
10	CH4626	Nut safety brine valve stand off	1

ASSEMBLIES

11	CH4700-27WR-1	.5 gpm safety float assembly, 18" x 33"	
	CH4700-34.5WR-1	.5 gpm safety float assembly, 18" x 40"	

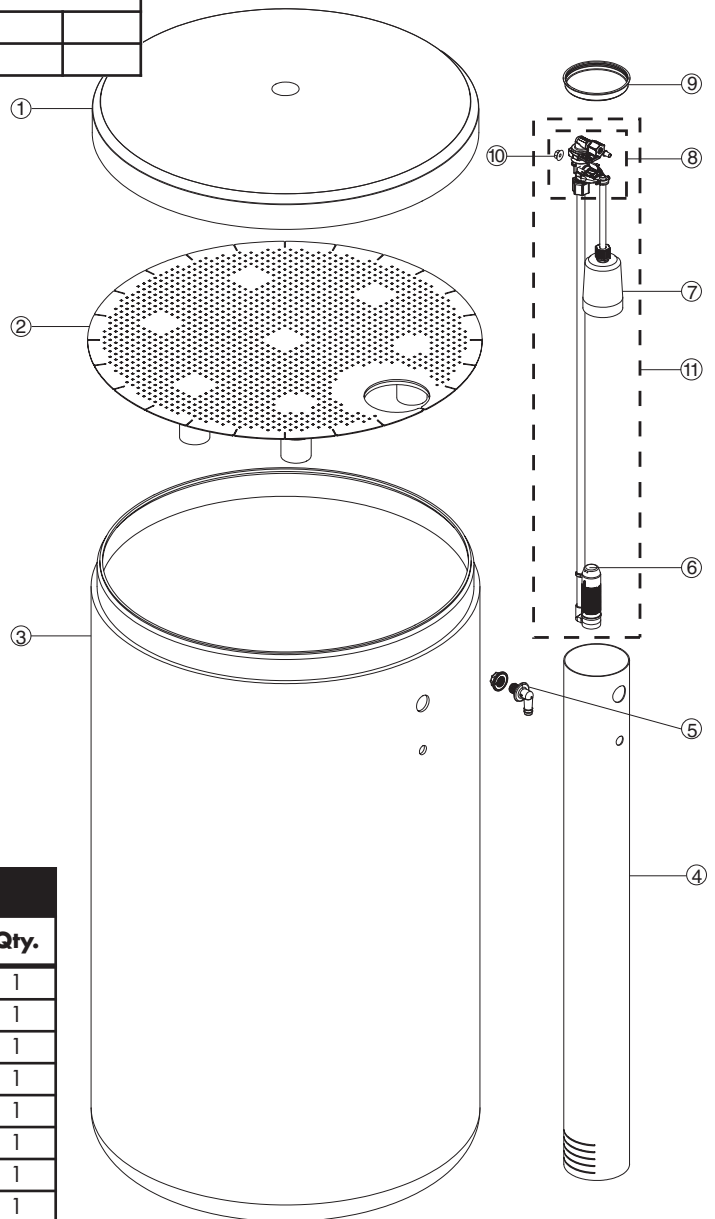
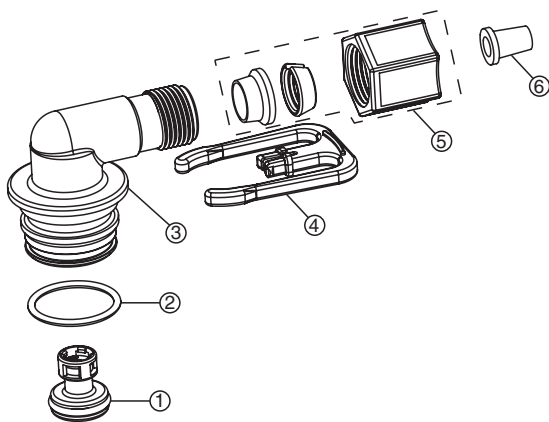

SAFETY FLOAT BRINE ELBOW

Item No.	Part No.	Description	Qty.
1	CH4655	474 .5 gpm flow control	1
2	CV3163	O-Ring 019	1
3	CH4613	3/8" elbow cap	1
	CH4612	1/2" elbow cap	1
4	CH4615	Elbow locking clip	1
5	CJCPG-5PBLK	3/8" compression nut	1
	CJCPG-8PBLK	1/2" compression nut	1
6	FP10332	Poly tube insert	1

INSTALLATION FITTING ASSEMBLIES:

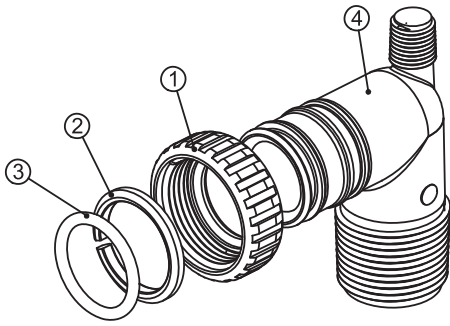

1" PVC MALE NPT ELBOW

Item No.	Part No.	Description	Qty.
	CV3007	1" PVC male NPT elbow assembly	2
1	CV3151	Nut, 1" quick connect	2
2	CV3150	Split ring	2
3	CV3105	O-ring 215	2
4	CV3149	Fitting	2

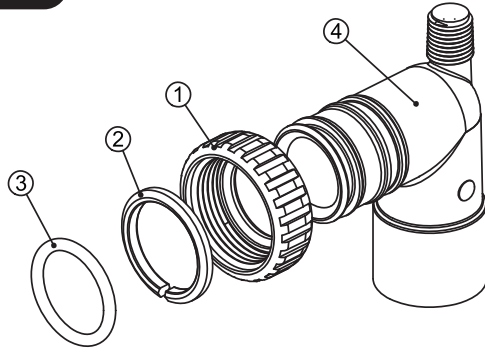

3/4" & 1" PVC SOLVENT ELBOW

Item No.	Part No.	Description	Qty.
	CV3007-01	3/4" & 1" PVC solvent elbow assembly	2
1	CV3151	Nut, 1" quick connect	2
2	CV3150	Split ring	2
3	CV3105	O-ring 215	2
4	CV3189	Fitting	2

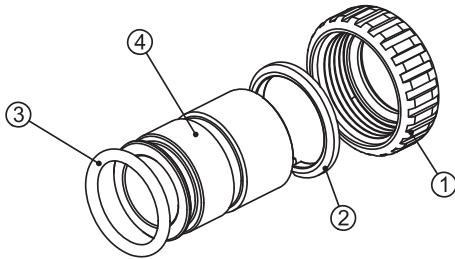

1" BRASS SWEAT

Item No.	Part No.	Description	Qty.
	CV3007-02	1" brass sweat assembly	2
1	CV3151	Nut, 1" quick connect	2
2	CV3150	Split ring	2
3	CV3105	O-ring 215	2
4	CV3188	Fitting	2

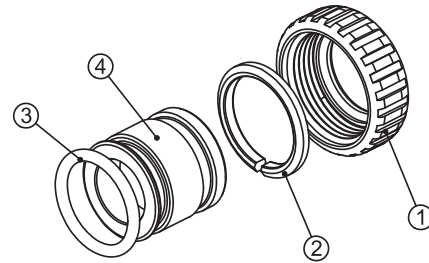

3/4" BRASS SWEAT

Item No.	Part No.	Description	Qty.
	CV3007-03	3/4" brass sweat assembly	2
1	CV3151	Nut, 1" quick connect	2
2	CV3150	Split ring	2
3	CV3105	O-ring 215	2
4	CV3188-01	Fitting	2

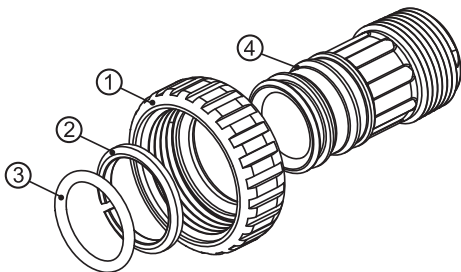

1" PLASTIC MALE NPT

Item No.	Part No.	Description	Qty.
	CV3007-04	1" plastic male NPT assembly	2
1	CV3151	Nut, 1" quick connect	2
2	CV3150	Split ring	2
3	CV3105	O-ring 215	2
4	CV3164	Fitting	2

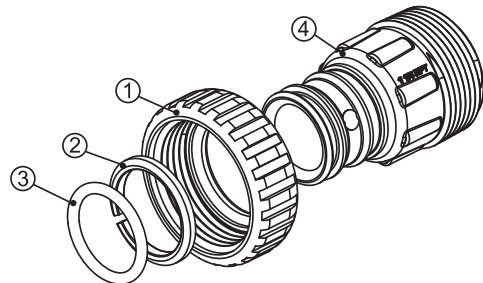

1-1/4" PLASTIC MALE

Item No.	Part No.	Description	Qty.
	CV3007-05	1-1/4" plastic male assembly	2
1	CV3151	Nut, 1" quick connect	2
2	CV3150	Split ring	2
3	CV3105	O-ring 215	2
4	CV3317	Fitting	2

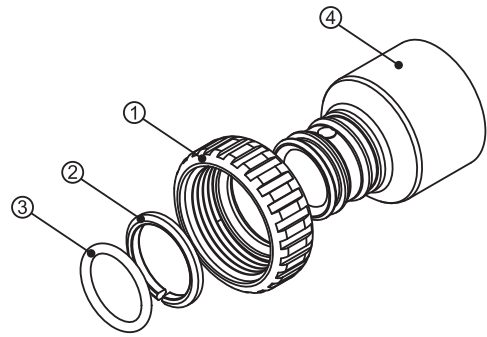
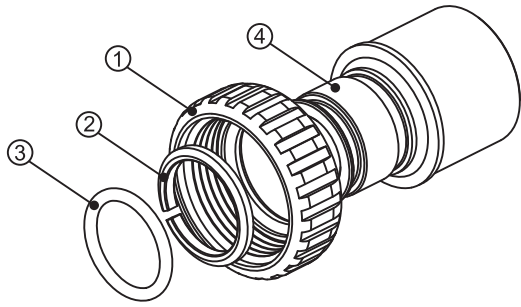

1-1/4" & 1-1/2" BRASS SWEAT			
Item No.	Part No.	Description	Qty.
	CV3007-09	1-1/4 & 1-1/2" brass sweat assembly	2
1	CV3151	Nut, 1" quick connect	2
2	CV3150	Split ring	2
3	CV3105	O-ring 215	2
4	CV3375	Fitting	2

1-1/4" & 1-1/2" PVC SOLVENT			
Item No.	Part No.	Description	Qty.
	CV3007-07	1-1/4" & 1-1/2" PVC solvent assembly	2
1	CV3151	Nut, 1" quick connect	2
2	CV3150	Split ring	2
3	CV3105	O-ring 215	2
4	CV3352	Fitting	2

SERVICE WRENCH - CV3193-01

Although no tools are necessary to assemble or disassemble the valve, the *Service Wrench*, (shown in various positions on the valve) is available to aid in assembly or disassembly.

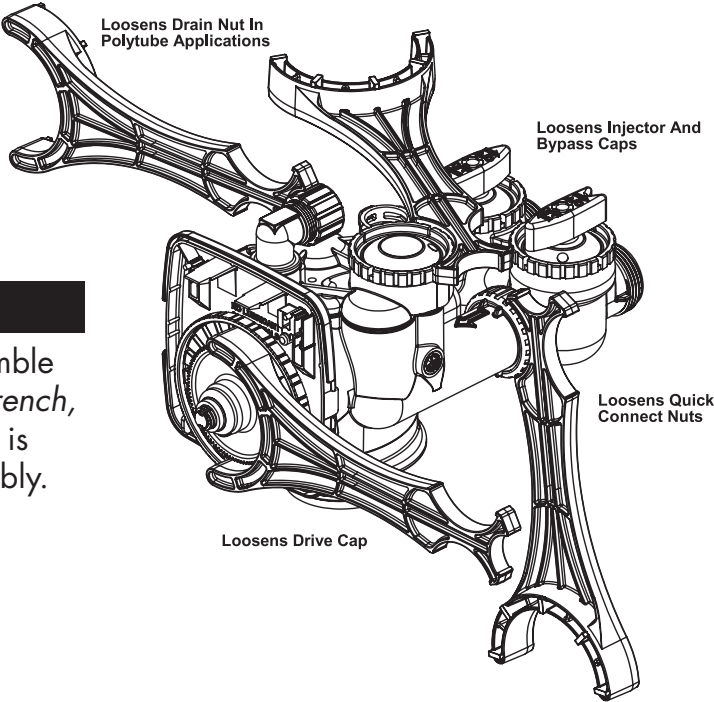

SPECIFICATIONS:

MODEL		ASP1-1044	ASP1-1054	ASP1-1354	ASP2-1044	ASP2-1054	ASP2-1354
¹ Capacity: (Grains/Lbs. NaCl)	Maximum	11,800 @ 12.4	22,600 @ 15.9	36,900 @ 21.2	20,300 @ 12.4	34,800 @ 15.9	60,300 @ 26.5
	Medium	11,400 @ 9.3	20,700 @ 12.4	33,600 @ 15.9	19,100 @ 9.3	32,000 @ 12.4	48,300 @ 15.9
	Minimum	7,300 @ 3.2	16,400 @ 6.1	28,300 @ 9.5	11,100 @ 3.2	22,900 @ 6.1	28,200 @ 9.3
Amount of Media (Cu. Ft.)		1.0	1.5	2.5	1.0	1.5	2.5
Maximum Water Hardness (GPG)		20	30	40	40	60	80
² Maximum Iron (PPM)		8.0	10.0	15.0	8.0	10.0	15.0
³ Minimum pH Required		6.5	6.0	6.0	7.0	7.0	7.0
⁴ Total pH Adjusted Water at Continuous Flows		630	252	432	NA	NA	NA
⁵ Peak Flow Rate (GPM @ P-PSI)		19 @ 15.0	17 @ 15.0	19 @ 15.0	19 @ 15.0	17 @ 15.0	19 @ 15.0
Continuous Flow Rate (GPM @ P-PSI)		9.0 @ 5.0	8.0 @ 5.0	9.0 @ 5.0	9.0 @ 5.0	8.0 @ 5.0	9.0 @ 5.0
Water Pressure Range (PSI)		25-100	25-100	25-100	25-100	25-100	25-100
Water Temp. (°F)		33-100	33-100	33-100	33-100	33-100	33-100
Electrical Requirements (volts-hertz)		110-50/60	110-50/60	110-50/60	110-50/60	110-50/60	110-50/60
Pipe Size		1"	1"	1"	1"	1"	1"
Total Dimensions:	Media Tank	10"W x 52"H	10"W x 62"H	13"W x 62"H	10"W x 52"H	10"W x 62"H	13"W x 62"H
	Brine Tank	18"W x 33"H	18"W x 33"H	18"W x 40"H	18"W x 33"H	18"W x 33"H	18"W x 40"H

MODEL		ASPR-1044	ASPR-1054	ASPR-1354	ASPR-844
¹ Capacity: (Grains/Lbs. NaCl)	Maximum	32,000 @ 15.0	48,800 @ 21.0	72,800 @ 24.0	25,600 @ 9.0
	Medium	28,400 @ 9.0	44,400 @ 15.0	64,200 @ 18.0	21,600 @ 6.0
	Minimum	23,600 @ 6.0	35,400 @ 9.0	53,000 @ 12.0	15,600 @ 3.0
Amount of Media (Cu. Ft.)		1.0	1.5	2.5	0.85
Maximum Water Hardness (GPG)		75	100	100	50
² Maximum Iron (PPM)		1.0	1.0	1.0	1.0
³ Minimum pH Required		7.0	7.0	7.0	7.0
⁴ Total pH Adjusted Water at Continuous Flows		NA	NA	NA	NA
⁵ Peak Flow Rate (GPM @ P-PSI)		17.1 @ 15.0	14.3 @ 15.0	18.5 @ 15.0	11.4 @ 15.0
Continuous Flow Rate (GPM @ P-PSI)		5.0 @ 2.8	5.0 @ 3.8	5.0 @ 2.4	5.0 @ 5.4
Water Pressure Range (PSI)		25-100	25-100	25-100	25-100
Water Temp. (°F)		33-100	33-100	33-100	33-100
Electrical Requirements (volts-hertz)		110-50/60	110-50/60	110-50/60	110-50/60
Pipe Size		1"	1"	1"	1"
Total Dimensions:	Media Tank	10"W x 52"H	10"W x 62"H	13"W x 62"H	8"W x 52"H
	Brine Tank	18"W x 33"H	18"W x 33"H	18"W x 40"H	18"W x 33"H

¹ All Sanitizer Plus water conditioners are pre-factory set at medium salting. Note: influent waters must be at least 3 GPG hardness and 80 TDS. A calcite or corsex unit may be needed for correct operation.

² Iron removal may vary depending on form of iron, pH and other local conditions. On waters that are pre-chlorinated or where other pre-oxidation occurs, an iron precipitate can form that is too small to be filtered.

³ The pH listed is the minimum for the influent water.

⁴ This is the minimum number of gallons at the continuous flow rate corrected to a 7 pH. The actual amount of pH adjusted water may be greater.

⁵ Unit not tested for capacity at these flow rates. Water quality may vary.

MODEL	ASP1-1044		ASP1-1054		ASP1-1354		ASP2-1044		ASP2-1054		ASP2-1354		ASPR-1044		ASPR-1054		ASPR-1354		ASPR-844	
	MIN.	GAL.	MIN.	GAL.	MIN.	GAL.	MIN.	GAL.	MIN.	GAL.	MIN.	GAL.	MIN.	GAL.	MIN.	GAL.	MIN.	GAL.	MIN.	GAL.
Brine Refill	5:51	3	9:53	5	11:53	6	5:51	3	9:53	5	11:53	6	5:51	3	9:53	5	11:53	6	3:51	2
Backwash	12	42	12	48	12	84	12	36	12	42	12	60	8	22	8	22	10	32	6	10
Brine & Rinse	72	29	90	36	90	72	72	29	90	36	90	72	60	24	90	36	90	47	40	16
Rapid Rinse	4	14	4	16	4	28	4	12	4	14	4	20	4	11	4	11	4	13	4	7
Total	94	88	116	105	118	190	94	80	116	97	118	158	78	60	112	74	116	98	54	35

QUICK REFERENCE GUIDE:

GENERAL OPERATION

When the system is operating, one of four displays will be shown: time of day/gpm, flow rate, capacity remaining or days to a regen. Pressing **NEXT** will toggle between the three choices.

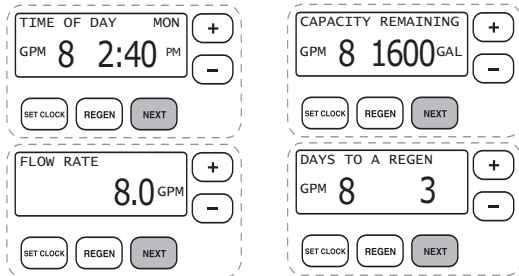

TO SET TIME OF DAY

In the event of a prolonged power outage, time of day flashes, indicating that this needs to be reset. All other information will be stored in memory no matter how long the power outage.

1. Accessed by pressing **SET CLOCK**
2. Adjust hours with **+** and **-** buttons, AM/PM toggles at 12
3. Press **NEXT**
4. Adjust minutes with **+** and **-** buttons
5. Press **NEXT**
6. Adjust current day with **+** and **-** buttons
7. Press **NEXT** to complete and return to normal operation

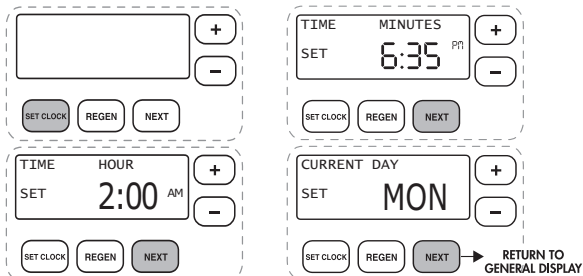

MANUAL REGENERATION

NOTE: For softeners, if brine tank does not contain salt, fill with salt and wait at least two hours before regeneration. If you need to initiate a manual regeneration, either immediately, or the same night at the preprogrammed time for regeneration (typically 2:00 AM), complete the following steps.

REGEN TODAY and TIME OF DAY will flash alternately if a regeneration is expected tonight.



For Immediate Regeneration:

Press and hold **REGEN** until valve motor starts (typically 3 seconds).

For Regeneration the same night:

Press and release **REGEN** (notice that flashing "REGEN TODAY" appears).

ERROR

If the display toggles between "Error" and an error code (i.e. a number), call a service technician and report the error code.

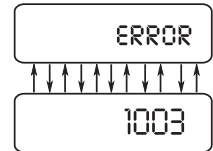

BYPASS VALVE OPERATION

To shut off water to the system, position arrow handles as shown in the bypass operation diagram below. If your valve doesn't look like the diagram below, contact your service technician for instructions on how to shut off water.

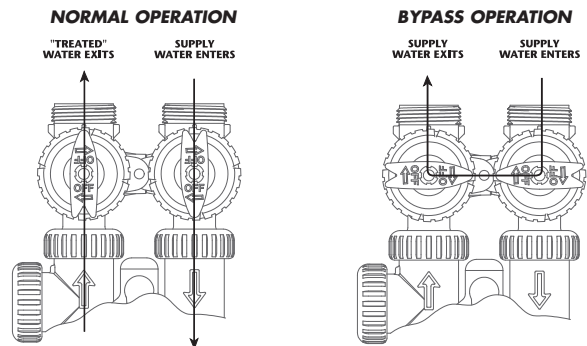

ADJUST HARDNESS, DAYS BETWEEN REGENERATION, TIME OF REGENERATION AND ALARM BUZZER

For initial set-up or to make adjustments, please complete the following steps.

1. Accessed by pressing **NEXT** and **+** button simultaneously
2. Adjust hardness using **+** and **-** buttons
3. Press **NEXT**
4. Adjust days between regenerations using **+** and **-** buttons
5. Press **NEXT**
6. Adjust time of regeneration hour with **+** and **-** buttons, AM/PM toggles at 12.
7. Press **NEXT**
8. Adjust time of regeneration minutes with **+** and **-** buttons
9. Press **NEXT**
10. Turn alarm buzzer ON or OFF with **+** and **-** buttons
11. Press **NEXT** to complete and return to normal operation.

