

# Commercial Electric Water Heater



# USE & CARE MANUAL

## WITH INSTALLATION INSTRUCTIONS FOR THE CONTRACTOR

The purpose of this manual is twofold: one, for the installing contractor, to provide requirements and recommendations for the proper installation and adjustment of the water heater; and two, for the owner-operator, to explain the features, operation, safety precautions, maintenance and trouble shooting of the water heater. This manual also includes replacement parts information.

It is imperative that all persons who are expected to install, operate or adjust this water heater read the instructions carefully so that they may understand how to do so.

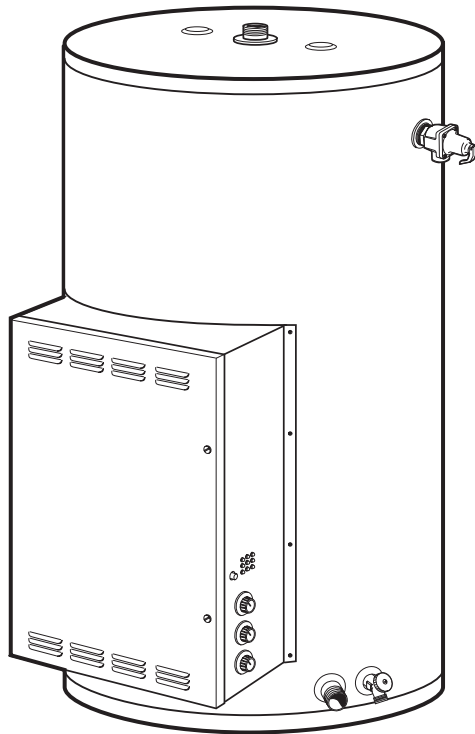

**Tank Type Models**  
Surface Mounted or Immersion Thermostats

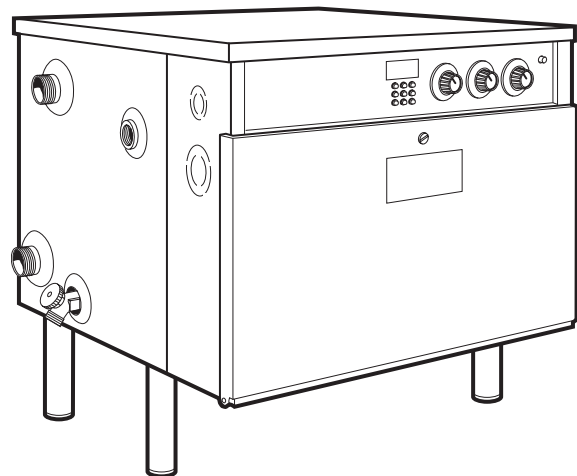

**Booster Models**  
Immersion Thermostats Only



**Do Not Destroy this Manual. Please read carefully and keep in a safe place for Future Reference.**



**Recognize this symbol as an Indication of Important Safety Information!**



**NOTICE:** This water heater is designed for use in a commercial application and the installation and maintenance of it should be performed by qualified, licensed service personnel. If the foregoing assumption is not appropriate, then we recommend that you obtain and retain our Residential Use & Care Manual.



**CALIFORNIA PROPOSITION 65 WARNING:** This product contains chemicals known to the State of California to cause cancer, birth defects or other reproductive harm.



# General Safety Precautions

Be sure to read and understand the entire Use & Care Manual before attempting to install or operate this water heater. Pay particular attention to the following General Safety Precautions. Failure to follow these warnings could result in serious bodily injury or death. Should you have any problems understanding the instructions in this manual, STOP, and get help from a qualified installer or service technician or the local utility.

To meet commercial water use needs, all Immersion thermostat model water heaters are adjustable to deliver water up to 190°F. (88°C) Surface mounted thermostat model water heaters are adjustable to deliver 160°F (71°C) for the 50 gallon models and 180°F (82°C) for the 85 and 120 gallon models. However, water temperatures over 125°F (52°C) can cause severe burns instantly or death from scalds. This is the preferred starting point for setting the control for supplying general purpose hot water.

Maximum water temperatures occur just after the thermostat has shut off the elements. To find the hot water temperature being delivered, turn on a hot water faucet and place a thermometer in the hot water stream and read the thermometer.

The following chart details the relationship of water temperature and time with regard to scald injury and may be used as a guide in determining the safest water temperature for your applications.

### TIME / TEMPERATURE RELATIONSHIPS IN SCALDS

Temperature	Time to Produce Serious Burn
120° F. (49°C)	More than 5 minutes
125° F. (52°C)	1 1/2 to 2 minutes
130° F. (54°C)	About 30 seconds
135° F. (57°C)	About 10 seconds
140° F. (60°C)	Less than 5 seconds
145° F. (63°C)	Less than 3 seconds
150° F. (66°C)	About 1 1/2 seconds
155° F. (68°C)	About 1 second

Table courtesy of Shriners Burn Institute

**! DANGER**



**Water temperature over 125° (52°C) can cause severe burns instantly or death from scalds.**

**Children, disabled and elderly are at highest risk of being scalded.**

**See instruction manual before setting temperature at water heater.**

**Feel water before bathing or showering.**

**Temperature limiting valves are available, see manual.**

The temperature of the water in the heater can be regulated by adjusting the thermostat. To comply with safety regulations the thermostat was set at the factory to a setting corresponding to 120°F. (49°C) The illustration below pictures the thermostats used on the water heaters covered in this manual and how to adjust the water temperature.

To adjust the water temperature on Surface Mounted Thermostat models, insert a small straight screwdriver into slotted screw of indicator and move indicator to desired setting. See Operation Section of this Manual for details.

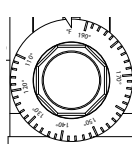

**Immersion Thermostat**

To adjust the water temperature on Immersion Thermostat models, turn thermostat dial to align desired mark with index line above thermostat. See Operation Section of this Manual for details.

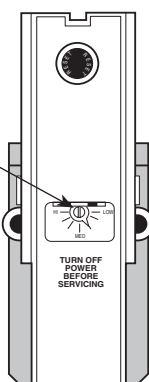

**Surface Mounted Thermostat**

TURN OFF POWER BEFORE SERVICING

**E-10 Model Only**

**CAUTION!! — Hotter water increases the risk of SCALDING!**

## **! DANGER**

There is a Hot Water SCALD Potential if the thermostat is set too high.

**NOTE:** When this water heater is supplying general purpose hot water requirements for use by individuals, a thermostatically controlled mixing valve for reducing point of use water temperature is recommended to reduce the risk of scald injury. Contact a licensed plumber or the local plumbing authority for further information.

Safety and energy conservation are factors to be considered when setting the water temperature on the thermostat. The most energy efficient operation will result when the temperature setting is the lowest that satisfies the needs consistent with the application.

---

# Introduction

---

## WARNING

Read and Review this entire Manual with special emphasis on the Installation Section (Pages 3 - 6) and Operation Section (Pages 7 - 8) prior to any installation work.

**LOCAL INSTALLATION REGULATIONS**—This water heater must be installed in accordance with these instructions, local codes, utility company requirements, and/or in the absence of local codes, the latest edition of the American National Standard / National Electrical Code. A copy of which can be purchased from the National Fire Protection Association, 1 Batterymarch Park, Quincy, MA 02269 as booklet NFPA 70.

### LOCATION

A. The water heater should be installed in a clean, dry location as close as practical to the area of greatest hot water demand. Long hot water lines should be insulated to conserve water and energy. The water heater and water lines should be protected from exposure to freezing temperatures. DO NOT install the water heater in an outdoor, unprotected area.

B. The water heater should not be located in an area where leakage of the tank or connections will result in damage to the area adjacent to it or to lower floors of the structure. When such areas cannot be avoided, it is recommended that a suitable catch pan, adequately drained, be installed under the water heater.

NOTE: Auxiliary catch pan installation MUST conform the applicable local codes.

C. FOR THE TANK TYPE MODELS, the minimum distance to provide adequate clearance for protection of combustible material is 0 inches (0 mm) from jacket and 18 inches (457mm) from access door. However, additional clearance for accessibility to permit inspection and servicing such as removing heating elements or checking controls must be provided. All models are approved for installation on combustible flooring.

### FOR THE BOOSTER MODELS

A minimum clearance of 18 inches (457mm) on the right side of the Booster model is required for removal of the heating element(s) when required for service or inspection.

Four separate 5/16-18 threaded openings are provided on the top, rear and bottom panels, so the heater may be bolted to a horizontal or vertical surface. If installed on a counter top, or stacked vertically in multiples, insert bolts and/or washers in bottom threaded openings to provide a minimum 1/4" (6mm) clearance so door hinges will not bind.

Factory designed accessories available for the Booster square model are: six inch adjustable stainless steel legs and a bracket kit for slide in "under counter" mounting or wall mounting of the water heater.

### D. RESTAURANT INSTALLATION:

If the water heater is to be installed in a restaurant, or other location where NSF International listing is required, it must be weather sealed to the floor, a raised base, or shelf so that seepage cannot accumulate under it; or elevated to provide at least (6) inches (152mm) of clearance from the floor.

The standard legs supplied with the Booster models provide the six (6) inches (152mm) of clearance in accordance with NSF International requirements.

For the Tank Type models, a factory designed sealing kit is available from the distributor or store where the water heater was purchased. When installed according to the instructions supplied with the kit, these heaters will meet the NSF International requirements.

---

# Installation

---

## WARNING

The manufacturer's warranty does not cover any damage or defect caused by installation, or attachment or use of any special attachment such as energy saving devices (other than those authorized by the manufacturer) into, onto, or in conjunction with the water heater. The use of such unauthorized devices may shorten the life of the water heater and may endanger life and property. The manufacturer disclaims any responsibility for such loss or injury resulting from the use of such unauthorized devices.

1. **INSPECT SHIPMENT**—for possible damage. The manufacturer's responsibility ceases upon delivery of goods to the carrier in good condition. Any claims for damage, shortage in shipments, or nondelivery must be filed immediately against carrier by consignee. Refer to Fig. 1 for installation with commercial dishwasher to provide hot water for sanitizing rinse. Note: Adjust the pressure reducing valve to the dishwasher manufacturer's recommended pressure (usually between 15 and 25 psi) (103-172kPa), with water flowing to the dishwasher.

2. **THERMAL EXPANSION** — Determine if a check valve exists in the inlet water line. It may have been installed in the cold water line as a separate back flow preventer, or it may be part of a pressure reducing valve, water meter or water softener. A check valve located in the cold water inlet line can cause what is referred to as a "closed water system". A cold water inlet line with no check valve or back flow prevention device is referred to as an "open" water system.

As water is heated, it expands in volume and creates an increase in the pressure within the water system. This action is referred to as "thermal expansion". In an "open" water system, expanding water which exceeds the capacity of the water heater flows back into the city main where the pressure is easily dissipated. A "closed water system", however, prevents the expanding water from flowing back into the main supply line, and the result of "thermal expansion" can create a rapid, and dangerous pressure increase in the water heater and system piping. This rapid pressure increase can quickly reach the safety setting of the relief valve, causing it to operate during each heating cycle. Thermal

# Installation

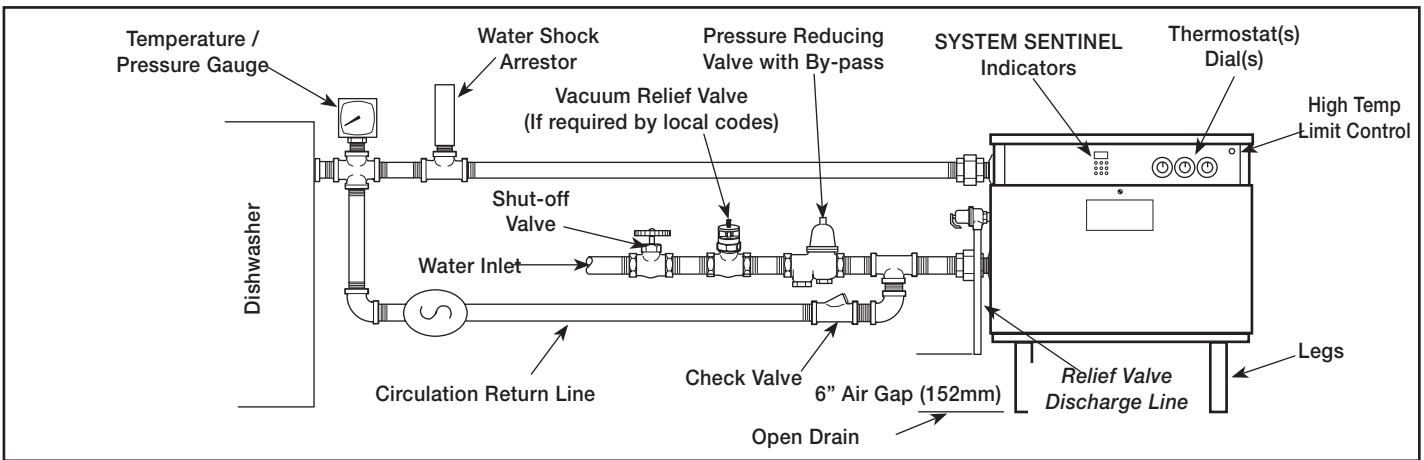

Figure 1. — Recommended installation for dishwashing sanitizing rinse application

expansion, and the resulting rapid, and repeated expansion and contraction of components in the water heater and piping system can cause premature failure of the relief valve, and possibly the heater itself. Replacing the relief valve will not correct the problem!

The suggested method of controlling thermal expansion is to install an expansion tank in the cold water line between the water heater and the check valve. The expansion tank is designed with an air cushion built in that compresses as the system pressure increases, thereby relieving the over pressure condition and eliminating the repeated operation of the relief valve. Other methods of controlling thermal expansion are also available. Contact your installing contractor, water supplier, or plumbing inspector for additional information regarding this subject.

If a recirculation line is installed, the return connection should be made to a tee close to the inlet connection on the water heater. A check valve should always be installed in the recirculation line to prevent cold water from entering.

Factory designed Equa-Flow Manifolds, and jacketed, insulated storage tanks are available.

**3. WATER CONNECTIONS**—This heater may be connected individually in multiples with others, or with an external hot water storage tank. It may also be used to boost the temperature of preheated water.

Inlet and outlet water connections are clearly marked next to the connections on the heater. Use only clean, new galvanized steel, copper or approved plastic for pipe for water connections. Local codes shall govern

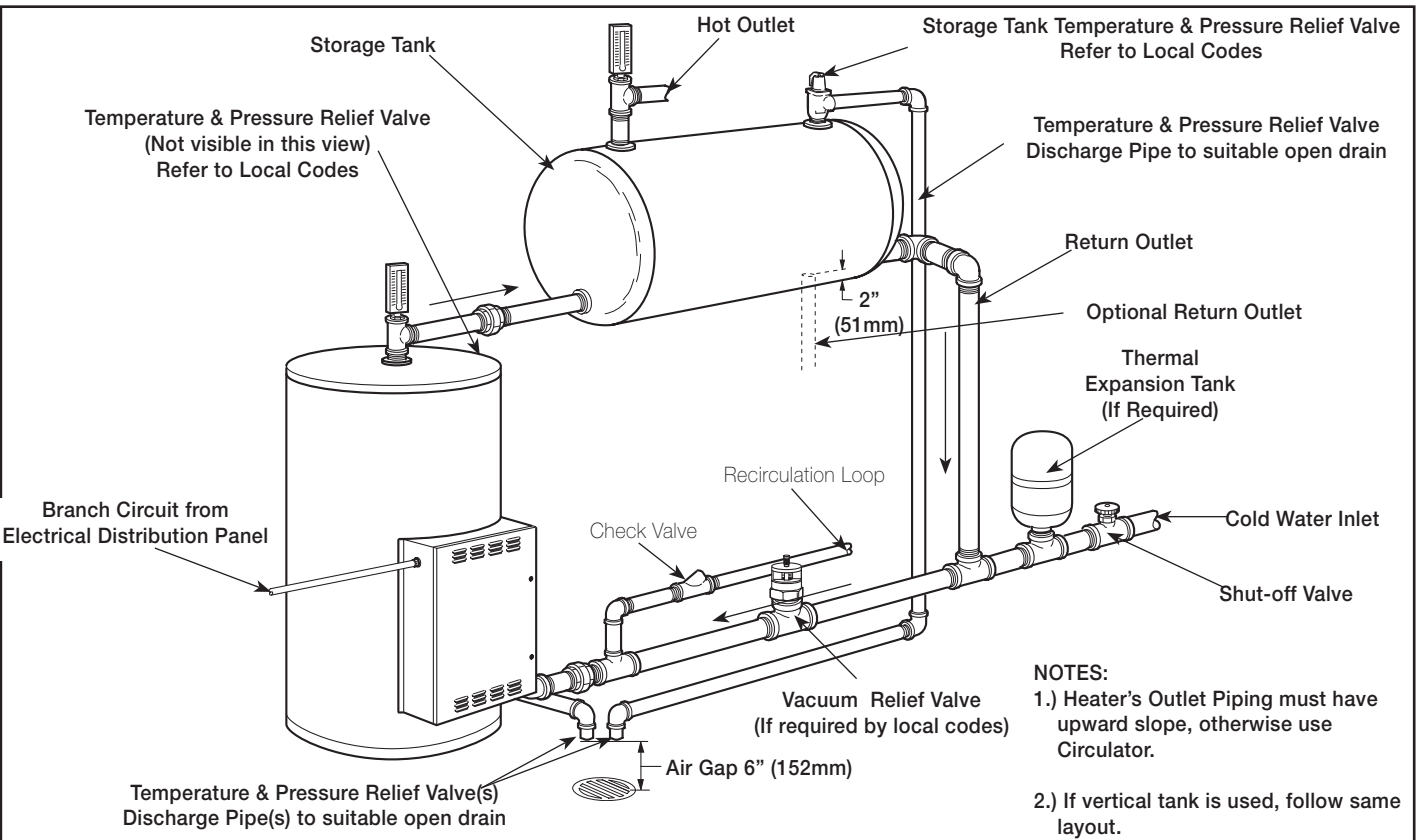

Figure 2. — Typical Gravity Circulating System

# Installation

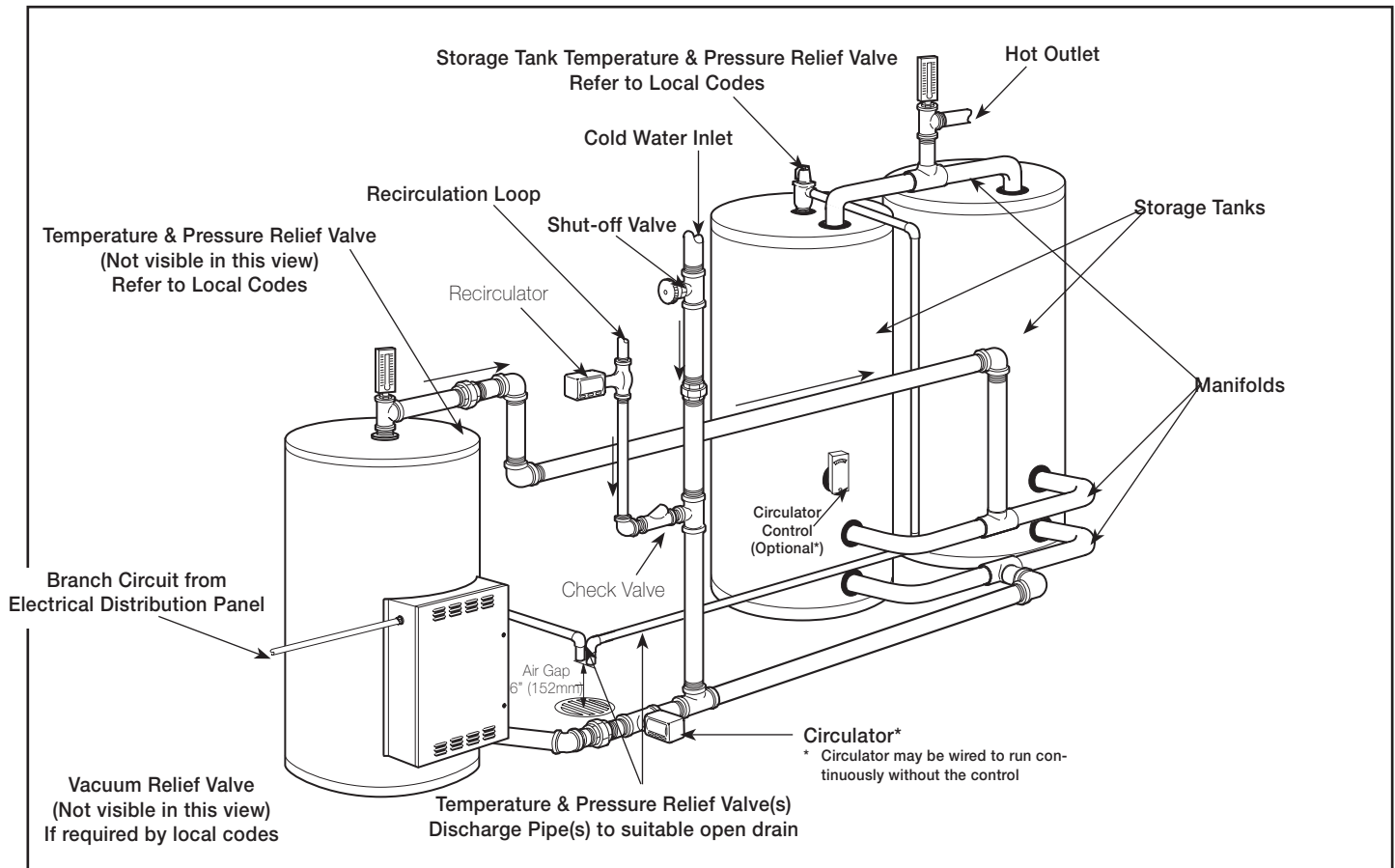

Figure 3. — Typical Forced Circulation Tank System with factory supplied jacketed and insulated storage tanks.

the exact type of material to be used. The installation of unions on the inlet and outlet water lines and a shut-off valve in at least the cold water line is recommended so the water heater may be easily disconnected for servicing. Dielectric unions are not required for protection of the water heater.

When this water heater is supplying general purpose hot water requirements for use by individuals, a thermostatically controlled mixing valve is recommended to reduce the risk of scald injury. Contact a licensed plumber or the local plumbing authority for further information.

Thermometer(s) should be installed so that they indicate the temperature of the water at or near the outlet of the water heater and storage tank(s) if provided. See Fig. 2 or 3.

**4. RELIEF VALVE** — A new combination pressure and temperature relief valve, complying with the Standard for Relief Valves and Automatic Gas Shutoff Devices for Hot Water Supply Systems, ANSI Z21.22, is factory installed on this water heater at the time of manufacture. No valve is to be placed between the relief valve and the water heater. For a circulating tank installation, the separate storage tank(s) must have similar protection. Local codes shall govern the installation of relief valves.

The pressure rating of the relief valve must not exceed 150 psi (1034kPa)(160 psi (1103kPa) for ASME models)), the maximum working pressure of the water heater as marked on the rating plate. The Btu/h rating of the relief valve must not be less than the input rating of the water heater as indicated on the rating plate located on the front of the heater. (1 watt = 3.412 Btu/h).

Connect the outlet of the relief valve to a suitable open drain so that the discharge water cannot contact live electrical parts. The discharge line must pitch downward from the valve to allow complete draining (by gravity) of the relief valve and discharge line and be no smaller than the outlet of the valve. The end of the discharge line should not be threaded or concealed and should be protected from freezing. No valve of any type, restriction or reducer coupling should be installed in the discharge line. Local codes shall govern the installation of relief valves.

**5. TO FILL WATER HEATER** — Make certain drain valve is completely closed. Open shut-off valve in cold water supply line. Open each hot water faucet slowly to allow air to vent from the water heater and piping. A steady flow of water from the hot water faucet(s) indicates a full water heater.

# Installation

kW	Phase	Recommended Over Current Protection Rating																	
		208				240				277				480					
		Voltage		Copper		Aluminum		Copper		Aluminum		Copper		Aluminum		Copper		Aluminum	
208	240	277	480	Wire Gauge	EMT Conduit**	Wire Gauge	EMT Conduit**	Wire Gauge	EMT Conduit**	Wire Gauge	EMT Conduit**	Wire Gauge	EMT Conduit**	Wire Gauge	EMT Conduit**	Wire Gauge	EMT Conduit**		
3	1	20	20	15	10	14	1/2	12	1/2	12	1/2	14	1/2	12	1/2	14	1/2	12	1/2
6	1	40	35	30	20	8	3/4	8	3/4	8	3/4	10	1/2	10	1/2	14	1/2	12	1/2
	3	25	20	NA	10	12	1/2	10	1/2	12	1/2	14	1/2	NA	NA	14	1/2	12	1/2
9	1	55	50	45	25	6	3/4	4	1	6	3/4	8	3/4	6	3/4	12	1/2	10	1/2
	3	35	30	NA	15	10	1/2	8	3/4	10	1/2	10	1/2	NA	NA	14	1/2	12	1/2
12	1	75	65	55	35	4	1	3	1	6	3/4	4	1	4	1	10	1/2	8	3/4
	3	45	40	NA	20	8	3/4	6	1	8	3/4	8	3/4	NA	NA	14	1/2	12	1/2
15	1	95	80	70	40	3	1	1	1 1/4	4	1	2	1 1/4	4	1	8	3/4	8	3/4
	3	55	50	NA	25	6	1	4	1 1/4	8	3/4	6	1	NA	NA	12	1/2	10	1/2
18	1	110	95	85	50	2	1 1/4	1 1/4	1 1/2	3	1	1	1 1/4	4	1	8	3/4	6	3/4
	3	65	55	NA	30	6	1	4	1 1/4	6	1	4	1 1/4	NA	NA	10	1/2	10	1/2
24	1	145	125	110	65	1 1/2	1 1/2	3 1/2	2	1	1 1/4	2 1/2	1 1/2	2	1 1/4	6	3/4	4	1
	3	85	75	NA	40	4	1 1/4	2	1 1/4	4	1 1/4	3	1 1/4	NA	NA	8	3/4	8	3/4
27	1	165	145	125	75	2 1/2	1 1/2	4 1/2	2	1 1/2	1 1/2	3 1/2	2	1	1 1/4	4	1	3	1
	3	95	85	NA	45	3	1 1/4	1	1 1/2	4	1 1/4	2	1 1/4	NA	NA	8	3/4	6	1
30	1	185	160	140	80	3 1/2	2	250MCM	2	2 1/2	1 1/2	4 1/2	2	1 1/2	1 1/2	4	1	2	1 1/4
	3	105	95	NA	50	2	1 1/4	1 1/2	1 1/2	3	1 1/4	1	1 1/2	NA	NA	8	3/4	6	1
36	1	220	190	165	95	4 1/2	2	300MCM	2 1/2	3 1/2	2	250MCM	2	2 1/2	1 1/2	3	1	1	1 1/4
	3	125	110	NA	55	1	1 1/2	2 1/2	2	2	1 1/4	1 1/2	2	NA	NA	6	1	4	1 1/4
45	1	275	235	205	120	300MCM	2 1/2	500MCM	2 1/2	250MCM	2	350MCM	2 1/2	4 1/2	2	1	1 1/4	1 1/2	1 1/2
	3	160	140	NA	70	2 1/2	2	4 1/2	2 1/2	1 1/2	2	3 1/2	2	NA	NA	4	1 1/4	3	1 1/4
54	1	325	285	245	145	400MCM	2 1/2	600MCM	3	300MCM	2 1/2	500MCM	2 1/2	250MCM	2	1 1/2	1 1/2	3 1/2	2
	3	190	165	NA	85	3 1/2	2	250MCM	2 1/2	2 1/2	2	4 1/2	2 1/2	NA	NA	4	1 1/4	2	1 1/4
60	1	360	315	275	160	500MCM	2.5	700MCM	3	400MCM	2.5	500MCM	2.5	300MCM	2 1/2	500MCM	2 1/2	4 1/2	2
	3	210	180	NA	90	4 1/2	2.5	300MCM	2.5	3 1/2	2	4 1/2	2.5	NA	NA	4	1.25	3	1.25
72	1	NA	NA	NA	NA	NA	NA	NA	NA	NA	NA	NA	NA	300MCM	2.5	3 1/2	2	250MCM	2
	3	250	220	NA	110	250MCM	2.5	350MCM	2.5	4 1/2	2.5	300MCM	2.5	NA	NA	2	1.25	1 1/2	2
81	3	NA	NA	NA	125	NA	NA	NA	NA	NA	NA	NA	NA	NA	NA	2 1/2	2	4 1/2	2 1/2
108	1	NA	NA	NA	NA	NA	NA	NA	NA	NA	NA	NA	NA	NA	NA	NA	NA	NA	NA
	3	NA	NA	NA	170	NA	NA	NA	NA	NA	NA	NA	NA	NA	NA	2 1/2	2	NA	NA

\* Table 1 - Minimum Branch Circuit and Wire Sizing Guide. Based on N.E.C. ANSI/NFPA 70 - 2002, Article 422.10(A); Article 240.6(A); Annex C Table C1 (EMT); Table 310.16 (Based on 75 C Type THW wire).

\*\* Conduit size based on NEC Code, Annex C Table C1 Maximum Number of Conductors or Fixture Wires in Electrical Metallic Tubing (EMT); 3 wires for single phase; 4 wires for 3 phase.

# Installation

## WARNING

Tank **MUST** be full of water before power is turned on. Heating elements **WILL BE DAMAGED** if energized for even a short time while tank is dry. The water heater's warranty does not cover damage or failure resulting from operation with an empty or partially empty tank. (Reference is made to the limited warranty for complete terms and conditions.)

### 6. ELECTRICAL CONNECTIONS & WIRING —

Check rating plate of water heater against supply for correct voltage. The water heater is completely internally wired from the factory to the field connection terminal block for a three phase connection. For single phase connections refer to the wiring diagrams in this manual and:

- A. Disconnect the red and black wires from the field terminal block legs 1, 2, and 3.
- B. Reconnect all black wires to leg 1 of the field terminal block.
- C. Reconnect all red wires to leg 2 of the field terminal block.
- D. Connect incoming power to field terminal block legs 1 and 2. Nothing will be connected to leg 3.

Provide a separate branch circuit with overcurrent protective device and suitable disconnecting means for each water heater. Refer to Table 1 above for minimum branch circuit sizing.

Water heater internal wiring diagrams are located in the back of this manual.

### 7. GROUNDING—

## CAUTION

The presence of water in the piping and water heater does not provide sufficient conduction for a ground. Nonmetallic piping, dielectric unions, flexible connections, Etc..., can cause the water heater to be electrically isolated.

The branch circuit should include either:

- A. Metallic conduit or metallic sheathed cable approved for use as a grounding conductor and installed with fittings approved for the purpose.
- B. Nonmetallic sheathed cable, or metallic conductor or metallic sheathed cable not approved for use as a grounding conductor, shall include a separate conductor for grounding. It shall be connected to the grounding means of the water heater (1/4" green screw) and that of the electrical distribution box. Terminate stranded grounding conductors with suitable pressure connectors .

### ALUMINUM WIRE CONNECTIONS

When aluminum wire is used for electrical supply leads, it is advisable to check the field terminal connections of a new installation twenty-four hours after the heater has been placed in service for possible need to retighten. Torque specs are marked on the terminal block.

# Operation

## SAFETY PRECAUTIONS

A. Do not turn off power to water heater if it has been subjected to over heating, fire, flood or physical damage.

B. **DO NOT** turn on water heater unless it is filled with water.

C. **DO NOT** turn on water heater if cold water supply shut-off valve is closed.

D. If there is any difficulty in understanding or following the OPERATION or MAINTENANCE instructions, it is recommended that a qualified person or serviceman perform the work.

Hydrogen gas can be produced in a hot water system served by this water heater that has not been

### ⚠ CAUTION

used for a long period of time (generally two weeks or more).

**HYDROGEN GAS IS EXTREMELY FLAMMABLE!!** To dissipate such gas and to reduce risk of injury, it is recommended that the hot water faucet be opened for several minutes at the kitchen sink before using any electrical appliance connected to the hot water system. If hydrogen is present, there will probably be an unusual sound such as air escaping through the pipe as the water begins to flow. Do not smoke or use an open flame near the faucet at the time it is open.

### TO PLACE WATER HEATER IN OPERATION:

#### ⚠ CAUTION

Make certain tank is completely filled with water before placing the water heater in operation. (Refer to Installation Section of this manual)

1. **WATER TEMPERATURE SETTING** — To comply with safety regulations and reduce the risk of scald injury, the thermostat(s) of the water heater has been set at the factory to a setting corresponding to 120° F. (49°C) This is the preferred starting point for setting the control for general purpose hot water. To meet commercial water needs, the Booster model's thermostat is adjustable to 190° F (88°C) to insure the 180° (82°C) F minimum for dishwasher rinse applications and other commercial purposes.

#### ⚠ WARNING

Water temperatures over 125°F (52°C) can cause severe burns instantly or death from scalds.

Safety and energy conservation are factors to be considered when setting the water temperature on the thermostat. The most energy efficient operation will result when the temperature setting is the lowest that satisfies the needs consistent with the application.

#### ⚠ DANGER

There is a hot water **SCALD POTENTIAL** if the thermostat is set too high.

**NOTE:** When this water heater is supplying general purpose hot water requirements for use by individuals, a thermostatically controlled mixing valve for reducing point of use water temperature is recommended to reduce the risk of scald injury. Contact a licensed plumber or the local plumbing authority for further information. Outlet water temperatures will vary during normal operating cycles. Reliable temperature readings should be taken shortly after the thermostat(s) cycle off during a period of little or no use.

If water temperature other than 120° F (49°C) is needed, the following instructions will apply depending on model.

#### SURFACE MOUNTED THERMOSTAT MODELS:

#### ⚠ DANGER

Be certain power to the water heater is turned OFF before adjusting temperature setting of thermostat.

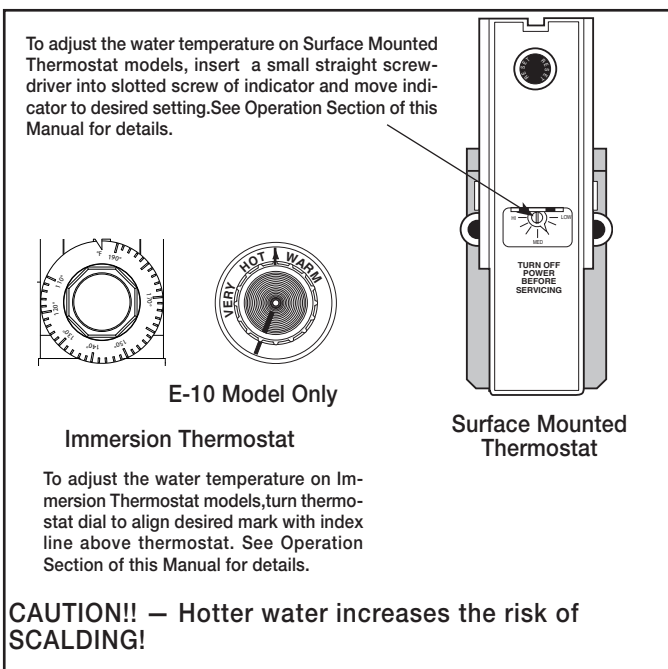

Figure 4. — Thermostat Adjustment



# Operation

There is one thermostat that controls all heating elements. It is located behind the removable pad of glass fiber insulation in the control compartment.

160°F (71°C) MODELS:

Adjust thermostat dial pointer, with a small screwdriver, to the desired water temperature setting (refer to Fig. 4). THERMOSTAT PROTECTIVE COVER SHOULD NOT BE REMOVED. The thermostat is adjustable from a "LOW" to "HI" setting. An approximate water temperature of 130° F (54°C) is accomplished when the temperature dial pointer is in the "MED" position. Each mark above and below the "MED" position indicates an approximate 10° F (6°C) change in water temperature. Replace insulation, close access door and turn power "ON", and the water heater is operational.

NOTE: A thermometer(s) installed at or near the outlet of the water heater and/or storage tank(s) will result in the most accurate outlet water temperature measurement.

180°F (82°C) GALLON MODELS:

Adjust thermostat dial pointer, with a small screwdriver, to the desired water temperature setting (refer to Fig. 4). THERMOSTAT PROTECTIVE COVER SHOULD NOT BE REMOVED. The thermostat is adjustable from a "LOW" to "HI" setting. An approximate water temperature of 150° F (66°C) is accomplished when the temperature dial pointer is in the "MED" position. Each mark above and below the "MED" position indicates an approximate 10° F (6°C) change in water temperature. Replace insulation, close access door and turn power "ON", and the water heater is operational.

NOTE: A thermometer(s) installed at or near the outlet of the water heater and/or storage tank(s) will result in the most accurate outlet water temperature settings.

IMMERSION THERMOSTAT MODELS:

NOTE: On Immersion Thermostat models, it is not necessary to turn power OFF before adjusting the temperature setting of the thermostat(s).

The adjustable thermostat dial(s) on these models is located on the exterior of the cabinet. A 140° F (60°C) setting is at the diamond mark between "WARM" and "HOT" on the dial (refer to Fig. 4). The range of settings are from an "OFF" position, indicated by the bar on dial, to 190° F (88°C) at the "VERY" position. This higher setting is provided to insure the required 180° F (82°C) minimum for dishwasher rinse applications and other commercial purposes. The "OFF" position can be used as a convenient means of conserving energy during periods of non-use.

2. HIGH TEMPERATURE LIMIT CONTROL — Both Surface and Immersion Thermostat models are equipped with a manual reset high temperature limiting control(s). If for any reason the water temperature becomes excessively high, The High Temperature Limit Control breaks the power to the heating elements. Once this control opens, it must be manually reset.

## CAUTION

The cause of the high temperature condition must be investigated by qualified service personnel and corrective action taken before placing the water heater in service again.

TO RESET HIGH TEMPERATURE LIMIT CONTROL:

## WARNING

Be certain the power supply to the water heater is turned "OFF" before attempting to reset the Limit Control.

NOTE: Allow the water in the tank to cool before resetting the High Temperature Limit Control.

On Surface Mounted Thermostat models, press the red "RESET" button located above the thermostat (refer to Fig. 4). The thermostat protective cover SHOULD NOT be removed.

On Immersion Thermostat models, the reset button is located on the outside of the control enclosure near the thermostat(s) dial(s).

3. EMERGENCY INSTRUCTIONS —

## WARNING

If the water heater has been subjected to flood, fire, or physical damage, turn off power and water to water heater. Do not operate the water heater again until it has been thoroughly checked by qualified service personnel.

4. LONG TIME SHUT-DOWN — If the water heater is to remain idle for an extended period of time (60 days or more), the power and water to the water heater should be turned off to conserve energy. The water heater and piping should be drained if they might be subjected to freezing temperatures. It is recommended that the water heater's operation and controls should be checked by qualified service personnel, before putting it in service again.

## WARNING

Make certain the water heater is completely filled before again placing it in operation.

NOTE: Refer to "Hydrogen Gas Caution" in Safety Precautions Section on page 8.

5. DRAINING HEATER —

## CAUTION

Be sure that the power to water heater is shut off before draining water.

## CAUTION

The water drained from the tank may be hot enough to present a SCALD HAZARD and should be directed to a suitable drain to prevent injury or damage.

In order to drain water heater, turn off cold water supply, then it is necessary to open a hot water faucet or lift the handle on the relief valve to admit air to the tank. Attach a garden hose to the drain valve on the water heater and direct the stream of water to a drain where it will do no damage.

# Maintenance

Properly maintained, this water heater will provide years of dependable, trouble free service. It is strongly suggested that a regular routine maintenance program be established and followed by the owner. It is further recommended that a periodic inspection of the relief valve and electrical controls be made by service personnel qualified in electric appliance repair.

## CAUTION

**Make certain all power to the water heater is turned “OFF” before performing any maintenance or inspection work on this water heater.**

**1. ELECTRICAL CONNECTIONS** — Periodic inspection of all electrical connections at the service terminal block, fuse holders, contactors, thermostats and elements should be performed to make certain all connections are tight. If the electrical supply leads used are aluminum, particular attention should be given to the branch circuit connections at the heater’s terminal block. It is advisable to retighten the field terminal connections of aluminum conductors twenty-four hours after the water heater was first placed in service. Torque specs are marked on the terminal block.

**NOTE:** On surface mounted thermostat models, make certain insulation is carefully replaced and tucked in before placing heater in operation. Also check the thermostat to be certain that it is located in its bracket and making good contact with the surface of the tank.

**2. FUSES** — Any replacement fuses should be of the same UL Class and type as the originals. The amp rating of the element circuit fuses may be reduced on those models not having high amperage elements.

**3. HEATING ELEMENTS** — The life of elements can be extended in hard water areas by removing the scale build up. Cleaning can be accomplished by scraping or soaking in a de-scaling solution. Care should be taken so the protective plating is not damaged by scraping or dissolved by excessive soaking.

## CAUTION

**Be certain all power to the water heater is turned “OFF” and tank has been completely drained before removing elements for cleaning.**

Whenever an element is removed from the tank for cleaning or replacement, a new gasket should be installed to prevent a possible water leak. Refer to parts information in this manual for replacement gasket information. The elements are easily unscrewed with a 1-1/2” socket wrench.

**4. RELIEF VALVE** — The Temperature and Pressure Relief Valve must be free to operate properly. Check operation (at least once a year) by lifting the handle fully and allowing several gallons of water to flush through the discharge line. Make certain the discharged water is directed to a suitable drain.

## DANGER

**Before manually operating the relief valve, make certain no one will be exposed to the danger of coming in contact with the hot water released by this valve. The water may be hot enough to create a SCALD hazard. The water released should be directed to a suitable drain to prevent injury or damage.**

**NOTE:** If the temperature and pressure relief valve on the water heater discharges periodically, this may be due to thermal expansion in a “closed” water system. Contact the water supplier or local plumbing inspector on how to correct this. **DO NOT** plug the relief valve outlet.

**5. TANK** — Good maintenance requires that the tank be cleaned of deposits. Unless the water supply is very soft (0 to 5 grains hardness), scale or lime deposits will accumulate in the tank. Hard water scale is deposited at an increasingly high rate in proportion to increased water temperature, and accumulation of these deposits may reduce efficiency and shorten the life of the water heater.

### CLEANING THE TANK:

The water heater is not supplied with a clean-out provision on the tank. To remove accumulated deposits from the tank, it is suggested that a few gallons of water be drained from the water heater’s tank through the drain valve every month to remove those deposits.

If chemical lime dissolving cleaners are preferred, cautiously follow the instructions supplied with the cleaner. **DO NOT** use a muriatic or hydrochloric acid (HCl) based cleaner.

**6. ANODE ROD INSPECTION** — This water heater is equipped with an anode rod designed to prolong the life of the glass lined tank. The anode is slowly consumed cathodically, thereby eliminating or minimizing corrosion of the glass lined tank.

Water sometimes contains a high sulfate and/or mineral content and together with the cathodic protection process can produce a hydrogen sulfide or rotten egg odor in the heated water. Chlorination of the water supply should minimize the problem.

The anode rod(s) should be removed from the water heater’s tank for periodic inspection. Replace the anode(s) when more than 6” (152mm) of core wire is exposed at either end of the rod.

If overhead clearance is not sufficient to allow installation of a rigid rod of original length, segmented rods in both standard and resistor versions are available.

**NOTE:** Do not remove the anode rod from the water heater’s tank, except for inspection and/or replacement, as operation with the anode rod removed will shorten the life of the glass lined tank and exclude warranty coverage.

## Maintenance

7. SEASONAL OPERATION — If the water heater is to remain idle for an extended period of time (60 days or more) the power to the heater should be turned off. The water heater and piping should be drained if they might be subjected to freezing temperatures. It is recommended that the water heater's operation is thoroughly checked (by qualified personnel) before it is placed back in service.

NOTE: Refer to "Hydrogen Gas Caution" in Safety Precautions Section on page 8.

8. GENERAL— Periodic cleaning of the equipment is recommended. Turn off power to heater. Remove any lint or dust that may block the free passage of air through the control compartment. **DO NOT** allow combustible materials such as newspapers, rags or mops to accumulate near the water heater.

## System Sentinel® System

This water heater is supplied with the System Sentinel® System. The system consists of an element diagnostic panel utilizing light emitting diodes (L.E.D.). The L.E.D.'s are lit only when the thermostat(s) is calling for element operation. This diagnostic system has L.E.D.'s corresponding to the number and location of heating elements and are energized when the elements are operating. An unlit L.E.D pinpoints the exact location of a non-functioning element, making element operation diagnosis simple and positive.

## Replacement Parts

The following Parts are required for Normal Maintenance for all Models:

SP21949 1 1/2" Socket Wrench for Element Head  
SP6708 Element Gasket

All other Parts can be ordered by providing the following information:

1. Description of Part(s), such as:  
Thermostat(s)\*  
Thermostat / High Temp Limit Assembly\*  
High Temperature Limit\*  
Control Transformer\*  
Heating Element (Include wattage and voltage)  
Anode Rod(s)  
Or other parts as required\*

2. Quantity of each part required.
3. Complete model number and name of the water heater.
4. Serial Number of water heater
5. Specify the voltage and KW rating.
6. Address Parts orders to your distributor or dealer.



\* For your safety, **DO NOT** attempt repair of Thermostats, High Limit Controls or any other control component. Refer repairs to qualified service personnel.

## How to Obtain Service Assistance

1. Should you have any questions about your new water heater, or if it requires adjustment, repair, or routine maintenance, it is suggested that you first contact your installer, plumbing contractor or previously agreed upon service agency. In the event that the firm has moved, or is unavailable, refer to the telephone directory commercial listings or local utility for qualified service assistance.

2. Should your problem not be solved to your complete satisfaction, you should then contact the Manufacturer's National Service Department at the following address:

2600 Gunter Park Drive  
Montgomery, Alabama 36109-1413  
Phone: 1-800-432-8373.

When contacting the manufacturer, the following information should be made available:

- a. Model and serial numbers of the water heater as shown on the rating plate attached to the jacket of the heater.
- b. Address where water heater is located and can be seen.
- c. Name and address of installer and any service agency who performed service on the water heater.
- d. Date of original installation and dates any service work was performed.
- e. Details of the problem as you can best describe them.
- f. List of people, with dates, who have been contacted regarding your problem.

# Wiring Diagram: Surface Mounted Thermostat Models -G Models 3 & 6 Element Models Only

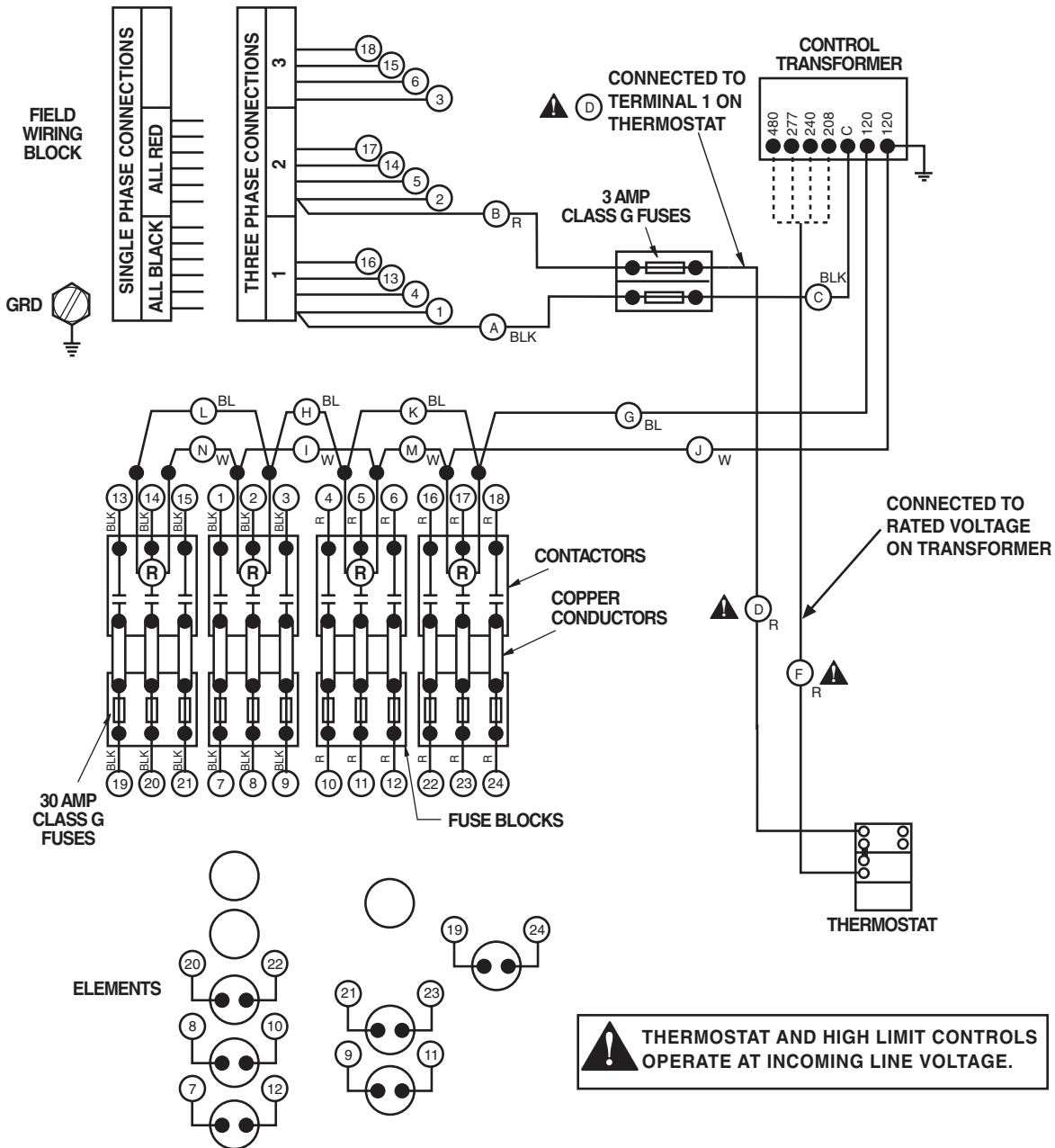

No. of Elements	Follow Wire Routes
3	1 thru 12, A thru J
6	1 thru 24, A thru N

**NOTE:**  
To insure proper thermostat response, be sure to replace insulation pad tightly over elements after servicing.

**NOTE:**  
THIS WATER HEATER MAY BE SUPPLIED BY A BRANCH CIRCUIT HAVING OVER 300 VOLTS BETWEEN CONDUCTORS, PROVIDED THE SYSTEM HAS A GROUND NEUTRAL AND NO CONDUCTOR IS OVER 300 VOLTS TO GROUND.

# Wiring Diagram: Surface Mounted Thermostat Models -G Models 9 Element Configuration Only

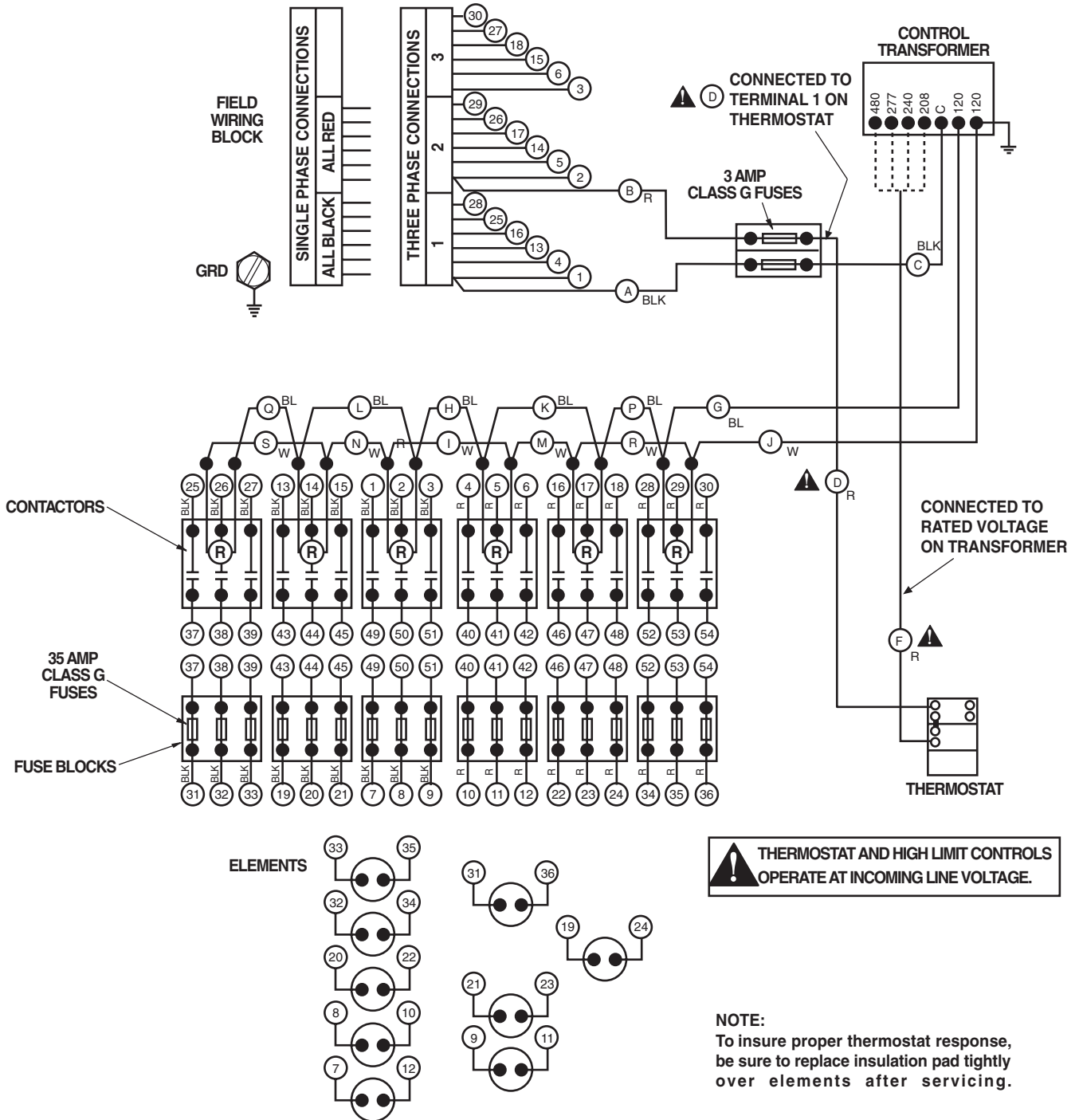

**NOTE:**  
THIS WATER HEATER MAY BE SUPPLIED BY A BRANCH CIRCUIT HAVING OVER 300 VOLTS BETWEEN CONDUCTORS, PROVIDED THE SYSTEM HAS A GROUND NEUTRAL AND NO CONDUCTOR IS OVER 300 VOLTS TO GROUND.

# Wiring Diagram: Immersion Thermostat Models

## -G Models 1 Element Configuration

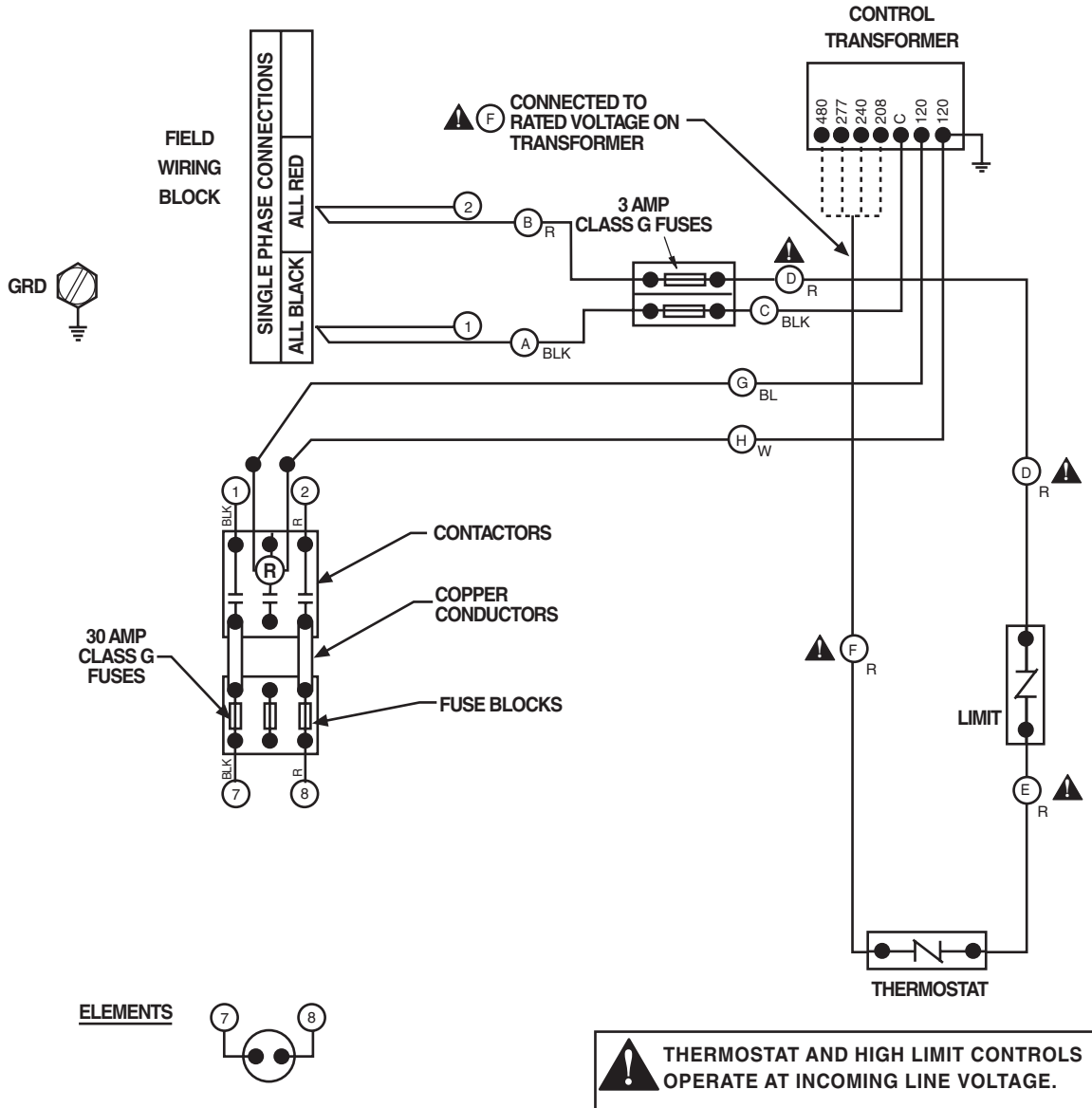

**NOTE:**  
THIS WATER HEATER MAY BE SUPPLIED BY A BRANCH CIRCUIT HAVING OVER 300 VOLTS BETWEEN CONDUCTORS, PROVIDED THE SYSTEM HAS A GROUND NEUTRAL AND NO CONDUCTOR IS OVER 300 VOLTS TO GROUND.

# Wiring Diagram: Immersion Thermostat Models

-G Models

3 & 6 Element Configurations Only

Up to 30 Amp Fuses

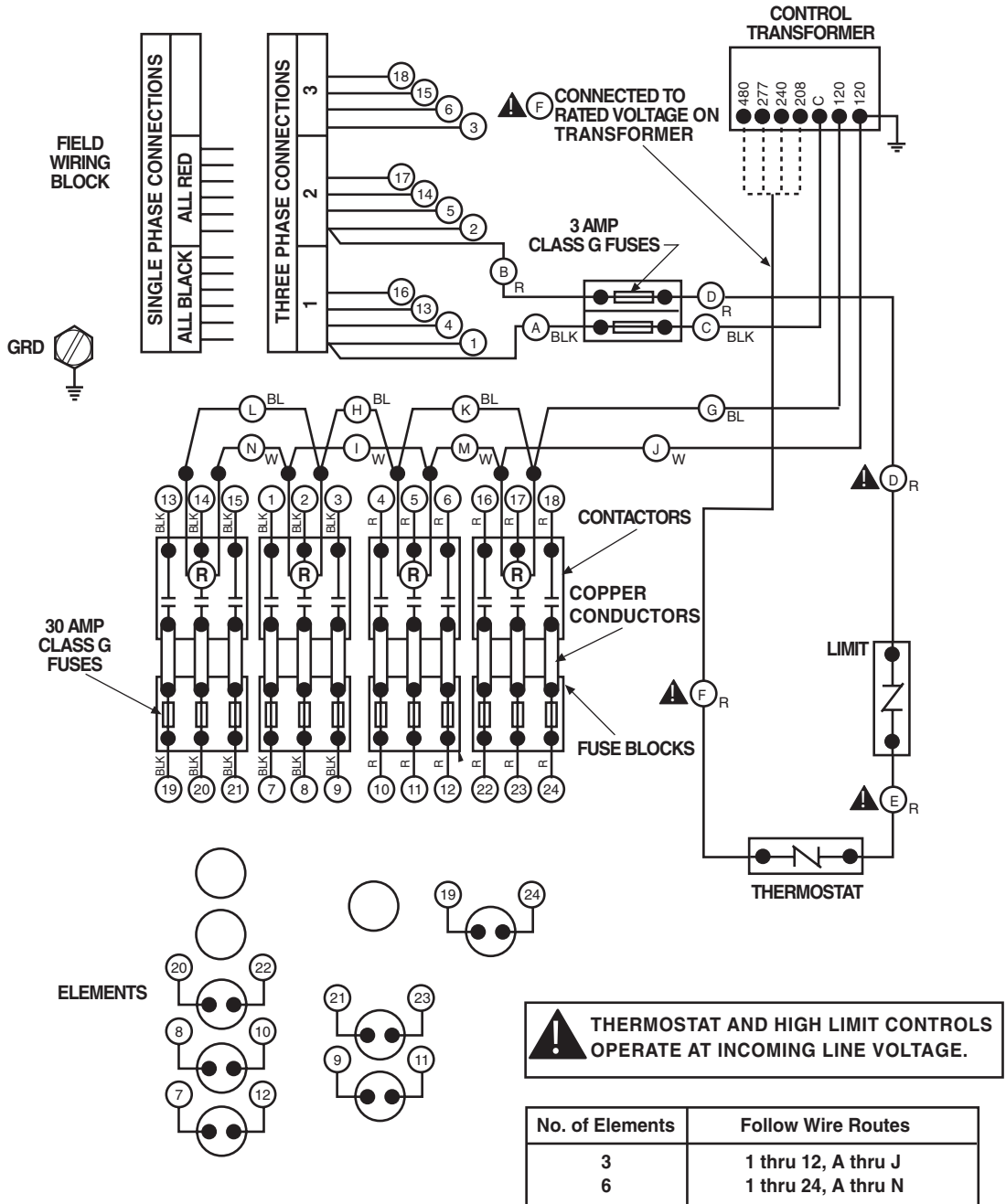

**NOTE:**  
THIS WATER HEATER MAY BE SUPPLIED BY A BRANCH CIRCUIT HAVING OVER 300 VOLTS BETWEEN CONDUCTORS, PROVIDED THE SYSTEM HAS A GROUND NEUTRAL AND NO CONDUCTOR IS OVER 300 VOLTS TO GROUND.

# Wiring Diagram: Immersion Thermostat Models

-G Models

3 & 6 Element Configurations Only

35 Amp Fuse

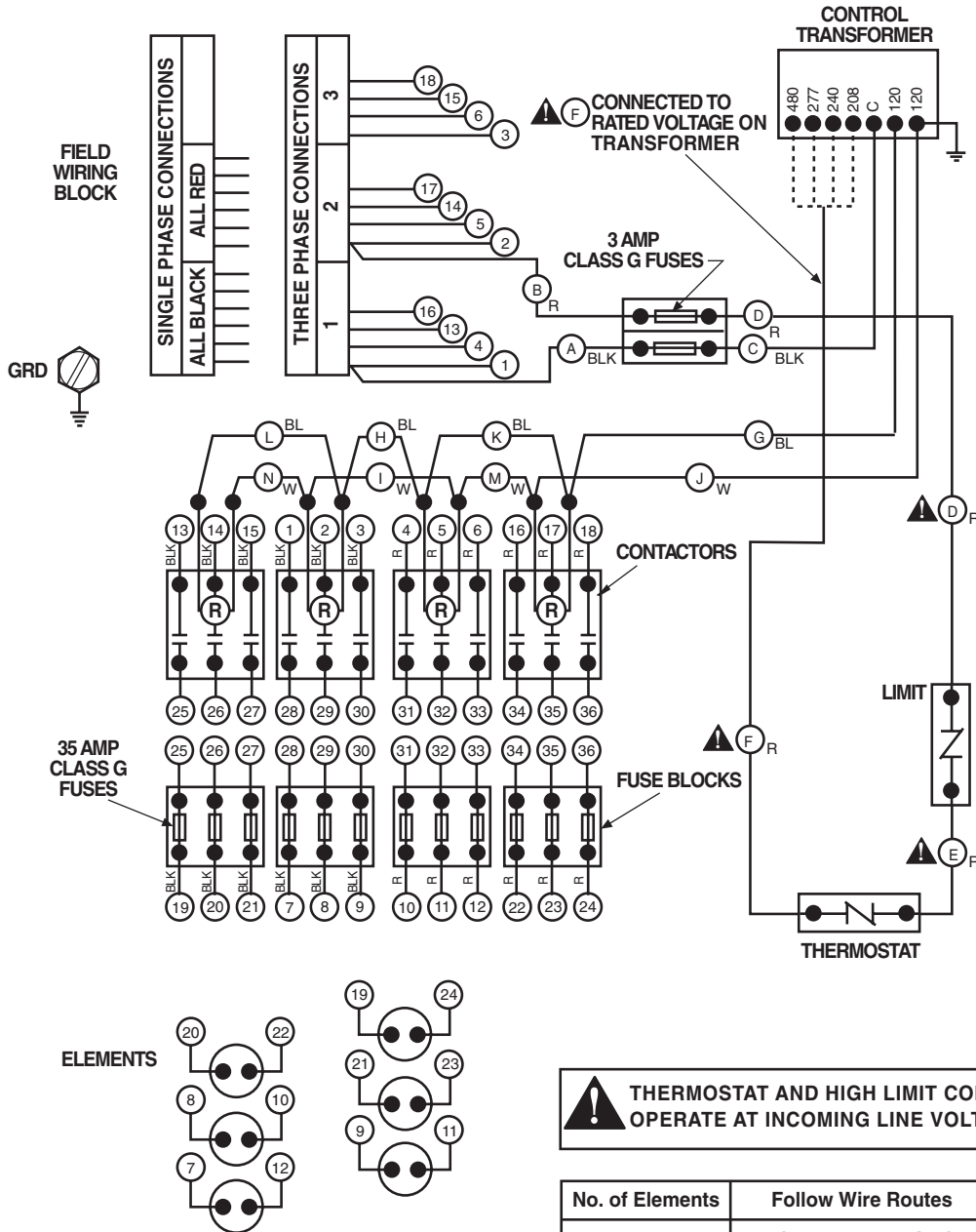

**NOTE:**  
THIS WATER HEATER MAY BE SUPPLIED BY A BRANCH CIRCUIT HAVING OVER 300 VOLTS BETWEEN CONDUCTORS, PROVIDED THE SYSTEM HAS A GROUND NEUTRAL AND NO CONDUCTOR IS OVER 300 VOLTS TO GROUND.



# Wiring Diagram: Immersion Thermostat Models -G Models 9 Element Configuration Only

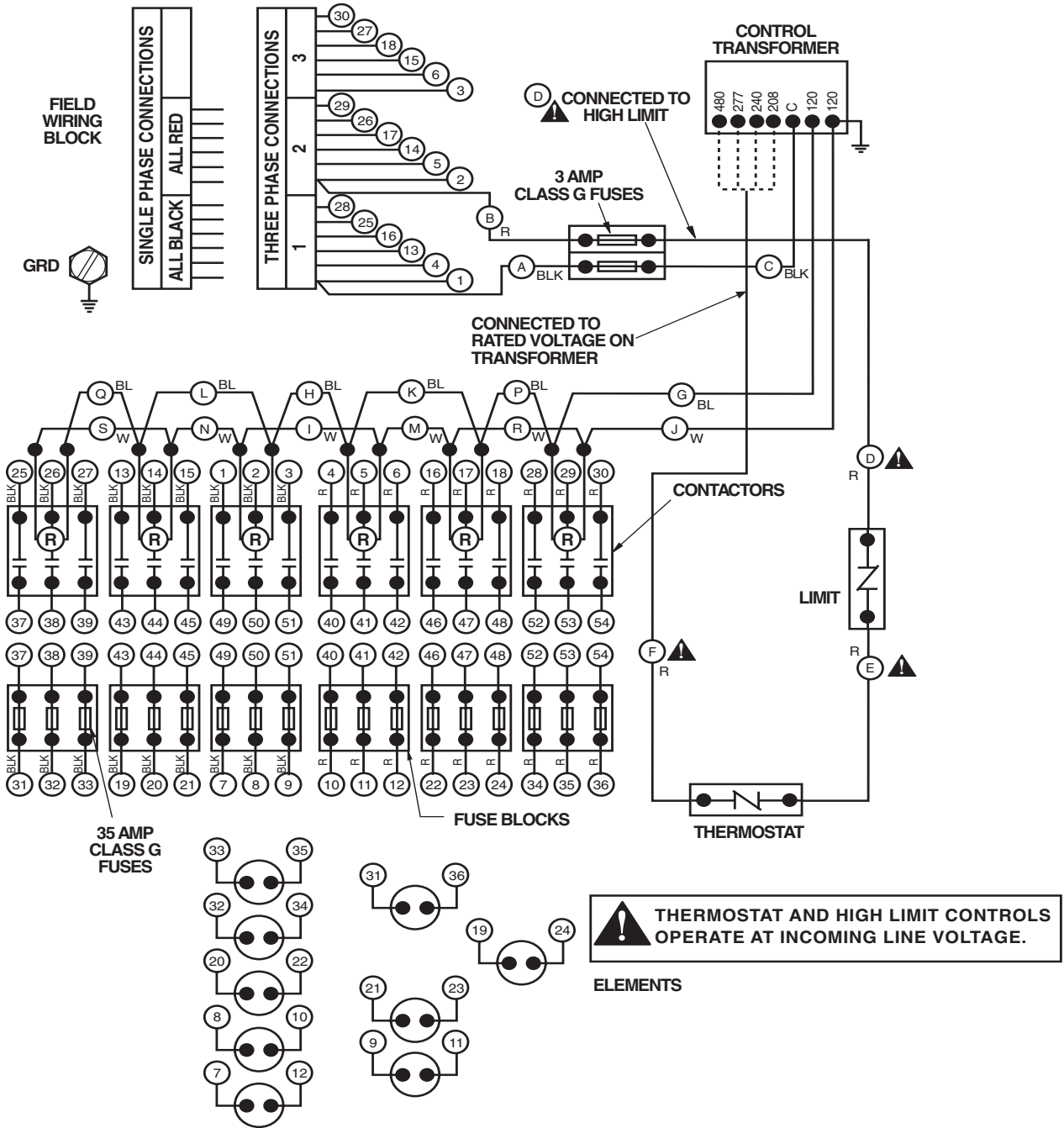

**NOTE:**  
THIS WATER HEATER MAY BE SUPPLIED BY A BRANCH CIRCUIT HAVING OVER 300 VOLTS BETWEEN CONDUCTORS, PROVIDED THE SYSTEM HAS A GROUND NEUTRAL AND NO CONDUCTOR IS OVER 300 VOLTS TO GROUND.

# Wiring Diagram: Immersion Thermostat Models with Staging

## 3 Stage -GS Models

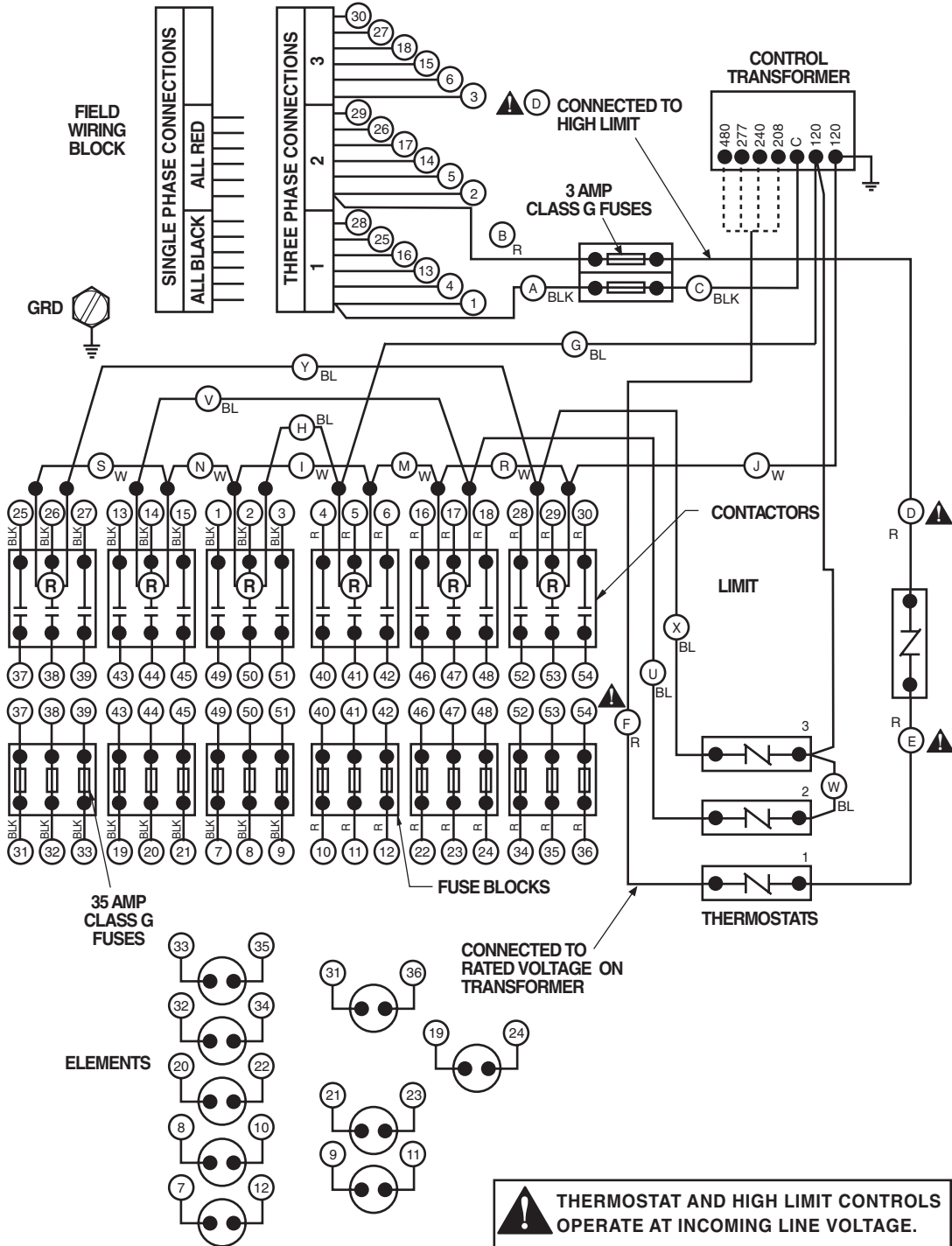

**NOTE:**  
THIS WATER HEATER MAY BE SUPPLIED BY A BRANCH CIRCUIT HAVING OVER 300 VOLTS BETWEEN CONDUCTORS, PROVIDED THE SYSTEM HAS A GROUND NEUTRAL AND NO CONDUCTOR IS OVER 300 VOLTS TO GROUND.

# Wiring Diagram: Immersion Thermostat Models with Staging

## 2 Stage -GS Models

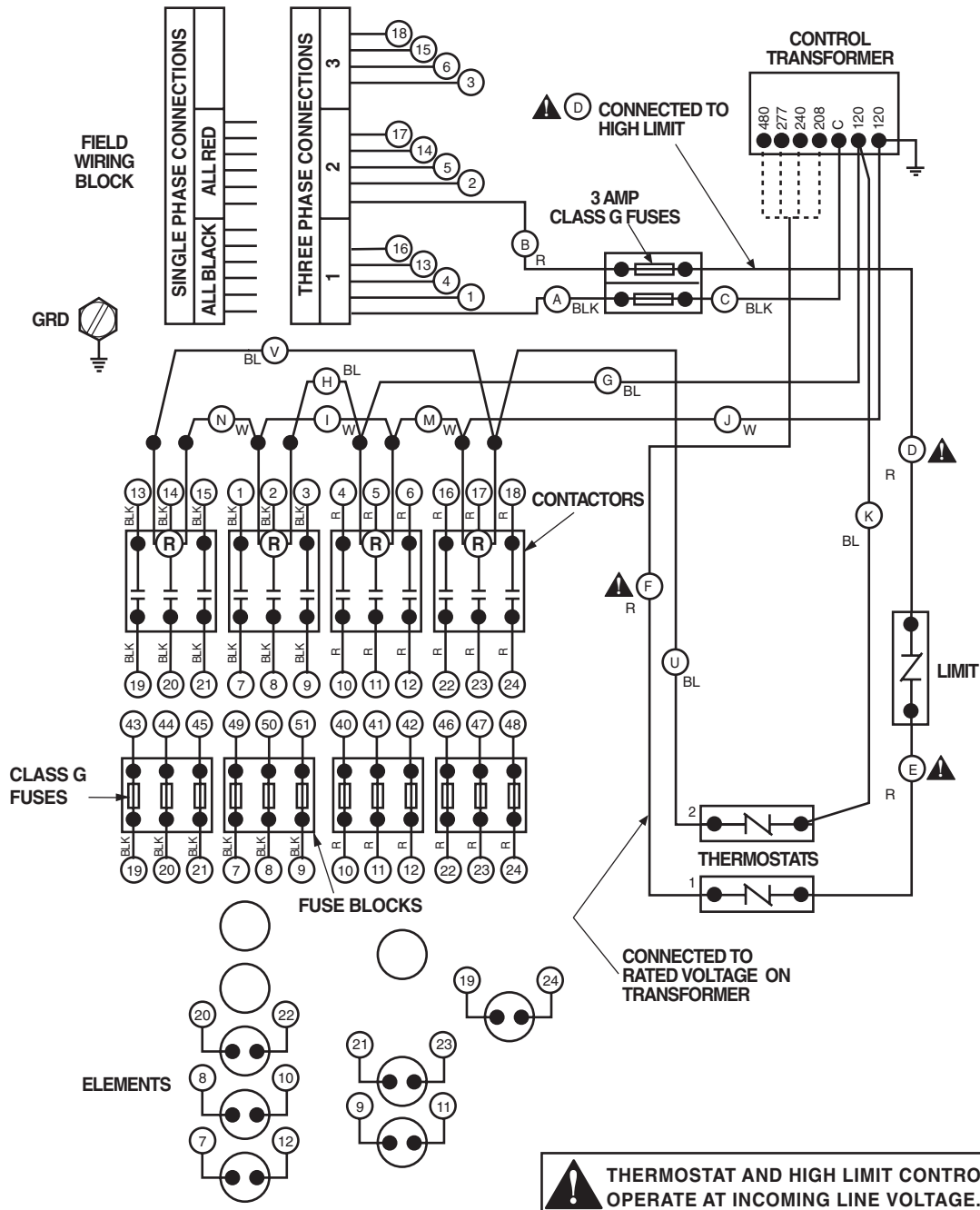

**NOTE:**  
THIS WATER HEATER MAY BE SUPPLIED BY A BRANCH CIRCUIT HAVING OVER 300 VOLTS BETWEEN CONDUCTORS, PROVIDED THE SYSTEM HAS A GROUND NEUTRAL AND NO CONDUCTOR IS OVER 300 VOLTS TO GROUND.

# Wiring Diagram: Immersion Thermostat Models -G Models

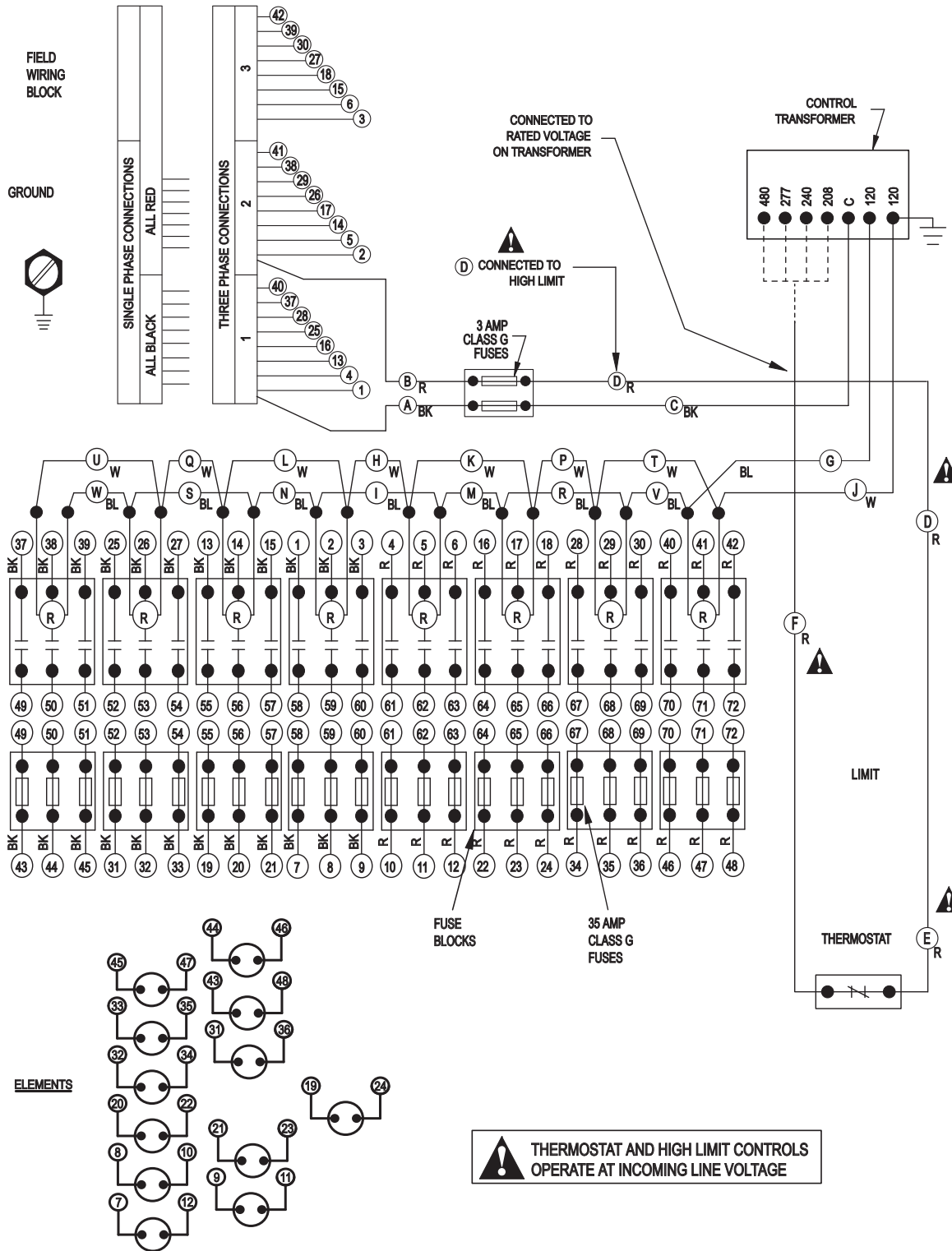

**NOTE:**  
THIS WATER HEATER MAY BE SUPPLIED BY A BRANCH CIRCUIT HAVING OVER 300 VOLTS BETWEEN CONDUCTORS, PROVIDED THE SYSTEM HAS A GROUND NEUTRAL AND NO CONDUCTOR IS OVER 300 VOLTS TO GROUND.

# Wiring Diagram: Immersion Thermostat Models 4 Stage -GS Models

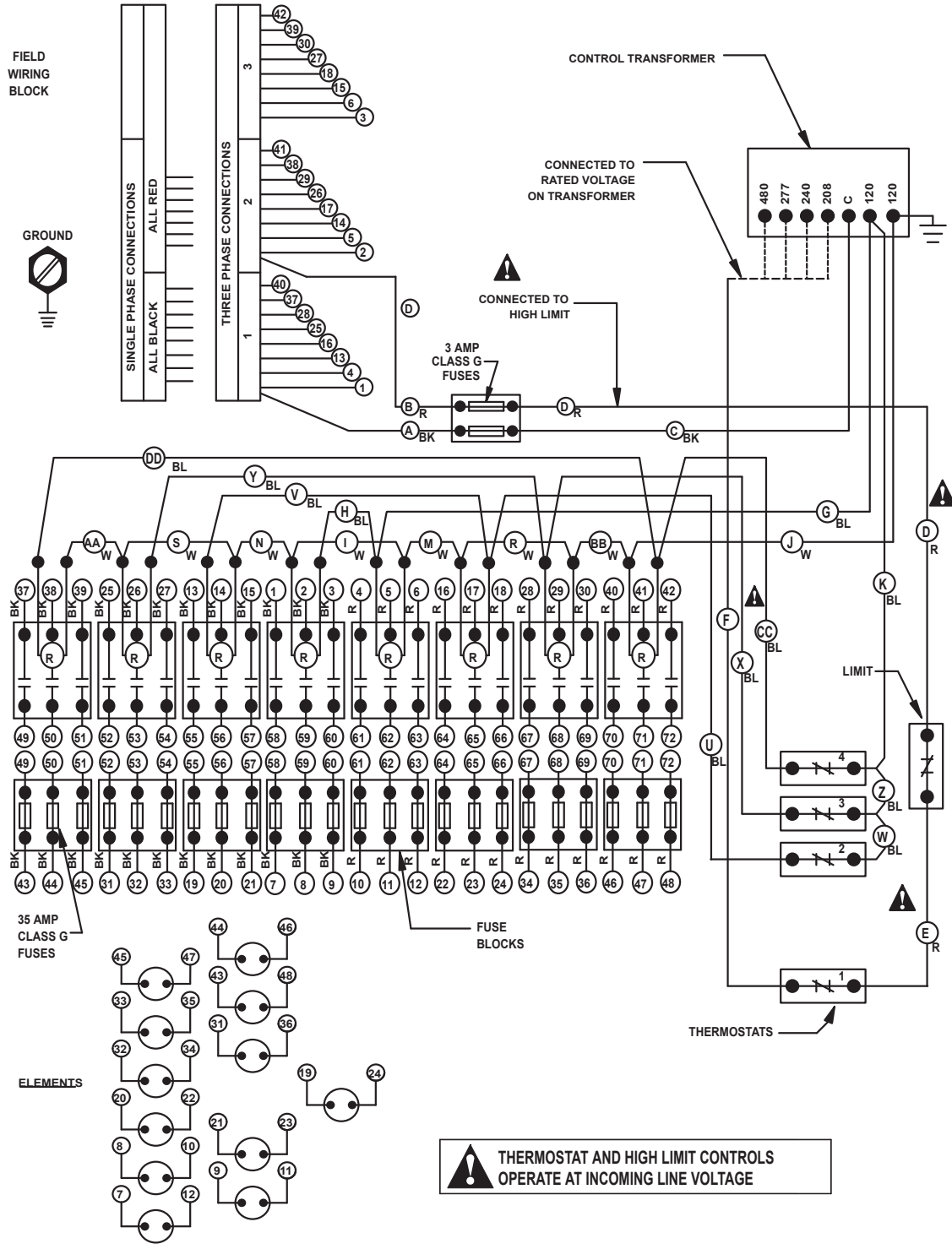

**NOTE:**  
THIS WATER HEATER MAY BE SUPPLIED BY A BRANCH CIRCUIT HAVING OVER 300 VOLTS BETWEEN CONDUCTORS, PROVIDED THE SYSTEM HAS A GROUND NEUTRAL AND NO CONDUCTOR IS OVER 300 VOLTS TO GROUND.

# Wiring Diagram: Immersion Thermostat Models -G Models

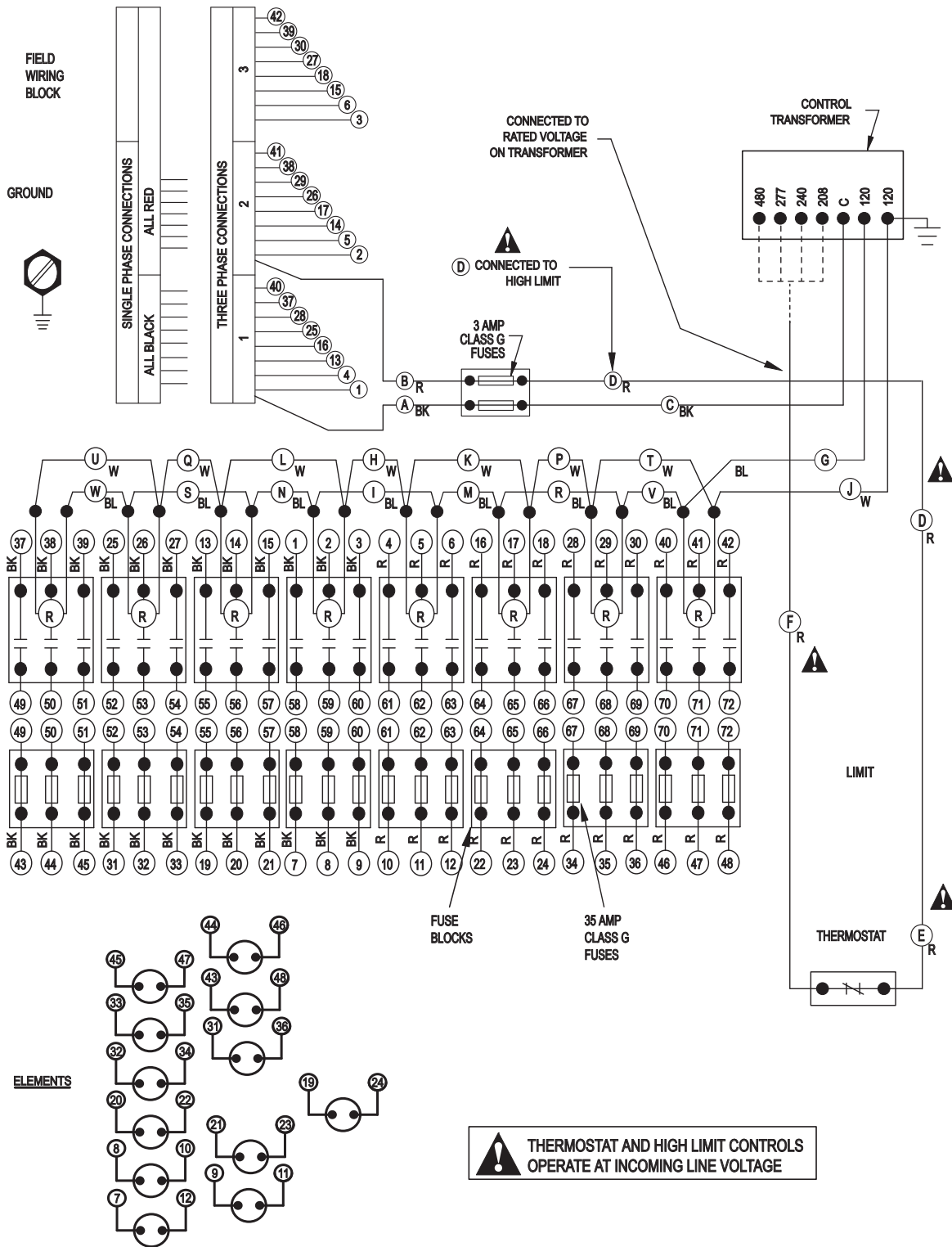

**NOTE:**  
THIS WATER HEATER MAY BE SUPPLIED BY A BRANCH CIRCUIT HAVING OVER 300 VOLTS BETWEEN CONDUCTORS, PROVIDED THE SYSTEM HAS A GROUND NEUTRAL AND NO CONDUCTOR IS OVER 300 VOLTS TO GROUND.

# Wiring Diagram: Immersion Thermostat Models 4 Stage -GS Models

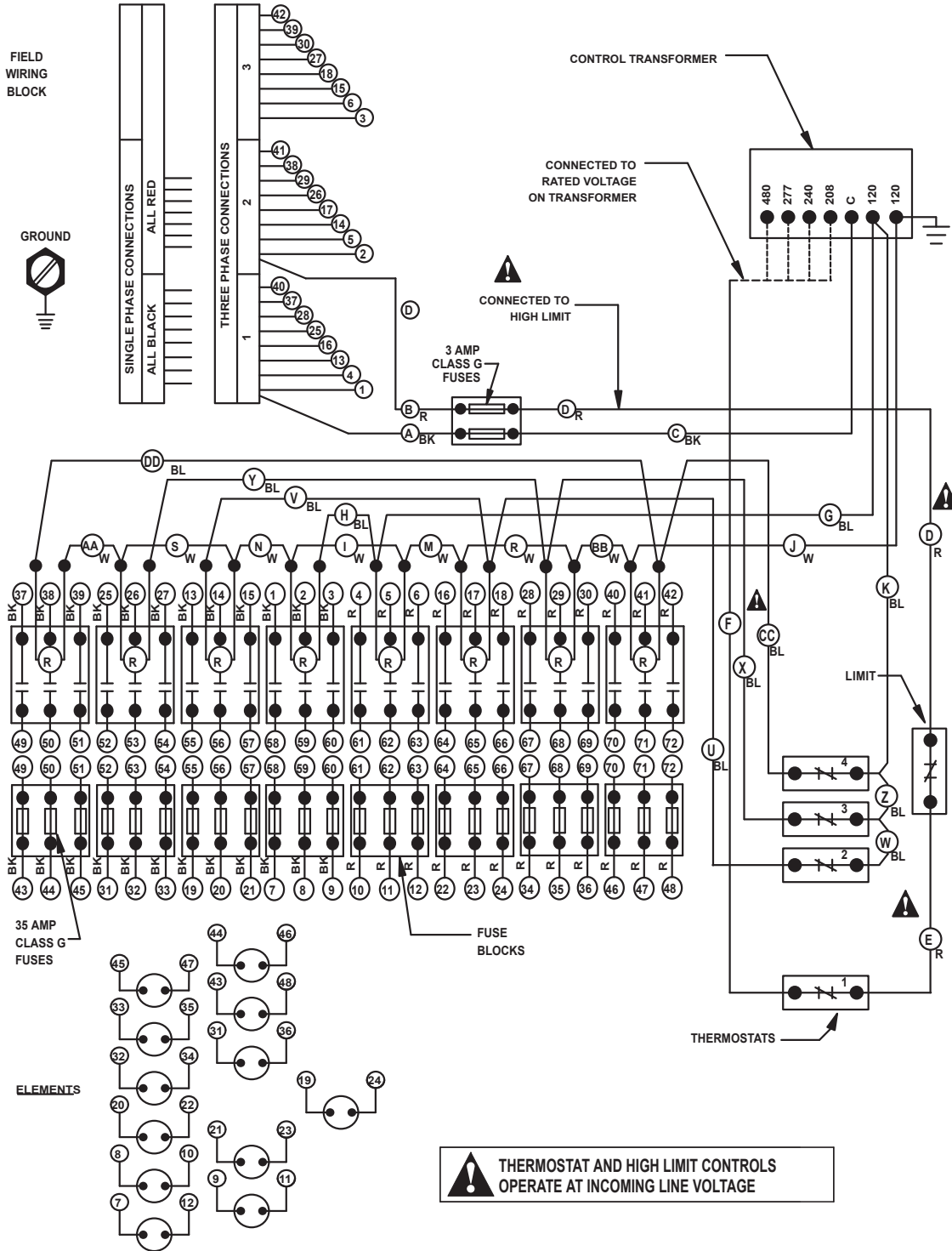

**NOTE:**  
THIS WATER HEATER MAY BE SUPPLIED BY A BRANCH CIRCUIT HAVING OVER 300 VOLTS BETWEEN CONDUCTORS, PROVIDED THE SYSTEM HAS A GROUND NEUTRAL AND NO CONDUCTOR IS OVER 300 VOLTS TO GROUND.

