



PENTAIR



STRUCTURAL
PRESSURE VESSELS'
ACCESSORIES & SPARE PARTS

WATER PURIFICATION

TANKS & SYSTEMS



TABLE OF CONTENT

MATERIALS.....	5
POLYMERS	5
RUBBERS/ELASTOMERS	6
METALS	6
USER GUIDE	7
WHAT IS WHAT	7
SYMBOLS & ICONS.....	8
INSTRUCTION	9
INSTALLATION INSTRUCTIONS	9
FLANGE ASSEMBLY	9
ASSEMBLY.....	10
ACCESSORIES	
CLOSURE & ADAPTERS	
2.5" THREAD	
2.5" CLOSURE PVC	11
4" THREAD	
DN 400	12
4" CLOSURE PVC	13
4" - 2.5" ADAPTER.....	14
6" THREAD	
6" CLOSURE PVC	15
6" FLANGE	
6" BLINDFLANGE	16
6" BLINDFLANGE ULTRA PURE	17
6" FLANGE - 1.5 BSP.....	18
6" FLANGE - 2.5" 8UN	19
6" FLANGE - 4" 8UN	20
6" FLANGE - DN65	21
6" FLANGE - DN80	22
6" FLANGE - DN100	23



BLINDFLANGE

DN50 FLANGE	24
DN65 FLANGE	25
DN80 FLANGE	26
DN100 FLANGE	27
DN125 FLANGE	28
DN150 FLANGE	29
DN200 FLANGE	30
DN400 FLANGE	31

DRAIN INSERTS

6" FLANGE

1" BSP OUTLET STANDARD	32
1" BSP OUTLET LOW FLOW	33
1" BSP OUTLET HIGH FLOW	34

SIGHT GLASS

SIGHTGLASS	35
------------------	----

VALVES

AERATION VALVES

1.5" AERATION VALVE	36
ADAPTER FOR AERATION VALVE 1.5"	37

2.5" VALVE

2.5" VALVE MANUAL VALVE - 3/4" INLET/OUTLET	38
---	----

TOOLS

WRENCHES

NOTCHED WRENCH FOR ADATORS	39
OCTOGON 2.5"	40
OCTOGON 4"	41
WRENCH FOR MANUAL VALVE	42

EXTENSIONS

EXTENSION 3/4 BSP	43
EXTENSION 2" BSP	44
EXTENSION HOLDER 6-FOLD HUB	45



SPARE PARTS

HUBS & HUB CONNECTORS

HUB	46
HUBCAP	47
HUB ADAPTORS	48
LATERAL	49
DIFFUSOR	50
UNION	51
ELBOW	52

SEALS

O'RING	53
FLAT SEAL.....	54



MATERIALS

POLYMERS

POLYETHYLENE (PE)

PE is the material used for the inner lining of standard Structural vessels and some closures and adaptors found in this catalogue.

Typical properties:

- Lightweight
- High toughness and elongation before break
- Very low water absorption & permeability
- High resistance to attack by chemicals
- Resistance to environmental stress cracking

POLYPROPYLENE (PP)

Injection molded material for standard laterals, hubs and hub adaptors

Typical properties:

- Similar properties as PE
- Higher temperature resistance than PE
- PP is Brittle when cold (below 10°C) (take care during cold assembly).

GLASSFIBER REINFORCED POLYPROPYLENE (PP-GF)

Injection molded material for high temperature laterals, hub adaptors. PP-GF has much higher stiffness than normal PP.

POLYPHENYLENEOXIDE (PPO)

Injection molded material for typical flanges and flanged closures. PPO is used as a 30% glass-filled product.

Typical properties:

- High dimensional stability
- High temperature resistance (up to 99°C)
- Good resistance to hydrolysis
- Self extinguishing, non-dripping
- Low water absorption

POLYVINYLIDENEFLUORIDE (PVDF)

Linings and components for ultra pure applications. PVDF is a high-grade technical polymer with excellent (chemical) properties.

Typical properties:

- High Toughness and elongation before break at high and low temperatures.
- Very high resistance to attack by most chemicals
- Suitable for ultra pure applications
- High mechanical strength.



POLYVINYLCHLORIDE (PVC)

Widely used polymer for water transportation systems, but also other applications. PVC is one of the world most used plastics. Structural uses PVC in some machined and injection molded parts of the distribution systems.

Typical properties:

- High mechanical strength, rigidity and hardness
- Low cold impact strength
- High chemical resistance
- Self extinguishing after removing ignition source

GLASSFIBER REINFORCED EPOXY (EP-GF)

Thermosetting material with a very high strength. Up to 60% glass-filled this plastic approaches the strength of aluminium, but has an even greater strength to weight ratio. It is not intended to come in contact with the contents of the vessel and is used as a reinforcing element only.

Typical properties:

- Very high strength & durability
- Structure elements only



RUBBERS/ELASTOMERS

ACRYLONITRILE BUTADIENE (NBR)

General purpose rubber compound

ETHYLENE-PROPYLENE-DIENE TERPOLYMER (EPDM)

Rubber compound with a better chemical and thermal resistance than standard NBR grade.

FLUOR-CARBON ELASTOMER (FPM)

Special grade (Viton ®) for specific applications. Suitable for most Ultra Pure or highly corrosive applications.



TETRAFLUORETHYLENE/ HEXAFLUORPROPYLENE (FEP)

Very high performance O-ring material. FEP seals are in fact made of a FPM inner core providing the necessary flexibility, enveloped by a seamless Teflon ® (PFA) cover.

Used where chemical, toxicological and thermal properties are of the utmost importance.



METALS

STAINLESS STEEL (SS)

All bolts are made of A2 (1.4303-1.4301-1.4541) grade stainless steel, all nuts, washers, spring washers etc. are grade A4 (1.4401-1.4571).

ALUMINIUM (AL)

Lightweight and corrosion resistant metal for construction of the flanges that are built in STRUCTURAL pressure vessels

For specific chemical resistance of one or more materials and agents, please contact our sales department. We will be happy to give advise.
Please specify the chemical exactly, along with its concentration & temperature.





USER GUIDE

WHAT IS WHAT

1
14" - 16" - 18"

2 
6" FLANGE

6 
65°C
1

7 

8 
DN65

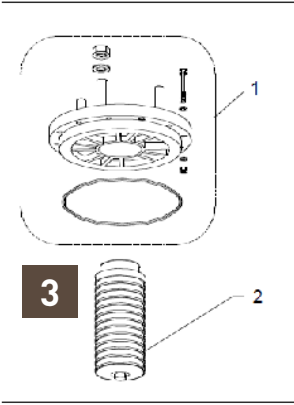
3 

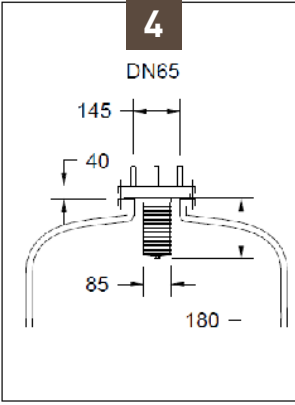
4 
DN65
145
40
85
180

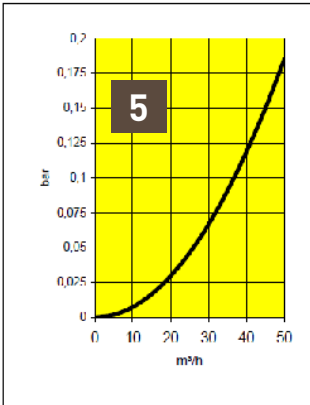
5 
0.2
0.175
0.15
0.125
0.1
0.075
0.05
0.025
0
0 10 20 30 40 50
m³/h

9 

10 
0.2 0.5

Item	Description	11	Dimensions	Quantity	Matière	N° d'article	
1	Adaptor		6" - DN65	1	PP	A-3100-02C	A-3100-02C
2	Diffusor		2.5" - 180mm	1	PP	A-2740--	A-2746--
						A-2727-F6	A-2527-F6

12 
1

13

1 Diameter of vessel

2 Vessel connection

3 Exploded View

4 Dimensions

5 Pressure drop curve

6 Operating temperature

7 Type of installation

8 System connection

9 Type of lateral connection

10 Lateral slot size

11 Spare parts list

12 Minimum order quantity

13 Codes



SYMBOLS & ICONS



Bajonet system



Threaded system



Slotsize of 0.2 mm



Slotsize of 0.3 mm



Slotsize of 0.5 mm



Slotsize of 12 mm



System or component for flanged vessels



System or component for threaded vessels



Threaded or flanged closures



Threaded or flanged adapters



Drain inserts



Tools and assembly aids



System for installation in top of flanged vessel



System for installation in bottom of flanged vessel



System for installation in top flanged vessel



System or component suitable from 1°C up to 50°C



System or component suitable from 1°C up to 65°C



System or component suitable from 1°C up to 99°C



Outward system connection



Adaptor function from ... to ...



Glue connection



Spare parts



System or component suitable for ultra



Maximum torque specification



Minimum order quantity



System for installation in top of threaded



System for installation in bottom of threaded vessel



System for installation in top threaded vessel



System for installation in top flanged vessel with sidehole



PENTAIR

INTRODUCTION



INSTRUCTION

INSTALLATION INSTRUCTIONS

- Please check parts on transport damage prior to assembly and installations.
- Protect the components from freezing 0°C (32°F).
- Pre-heating of the parts in warm water is recommended for assemblies below 10°C (50°F).
- Maximum torque to 5 Nm (3,69 ft.-lbs).

FLANGE ASSEMBLY

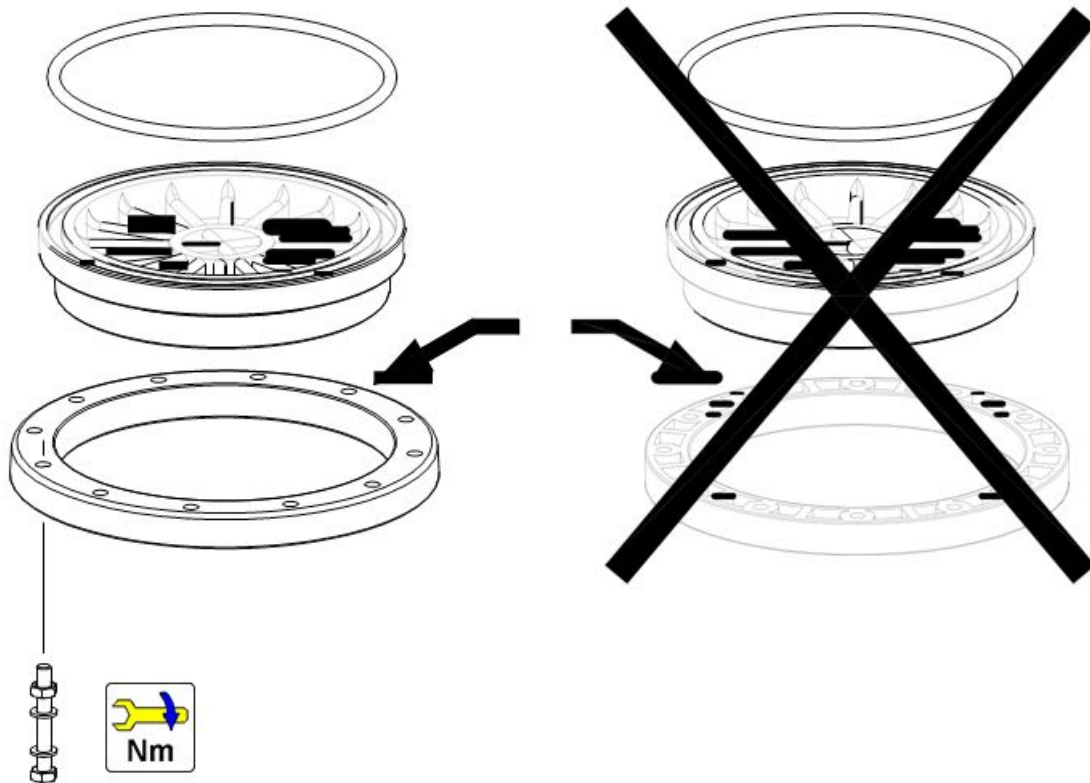



ASSEMBLY



Step 1: Unassembled parts with extension I-WR03-LA.



Step 2: Parts shown in Step 1 are assembled (outside of tank) and inserted in tank using extension I-WR03-LA.



Step 3: Put assembly inside the tank to mount laterals.



Step 4: Screw all laterals in hub while still holding extension.



Step 5: Screw flange adaptor on assembly. Be sure O-ring is attached and sealed properly to adaptor.



Step 6: Use backing flange to connect distribution system to 6" flange. Now remove extension.





PENTAIR

CLOSURES & ADAPTER

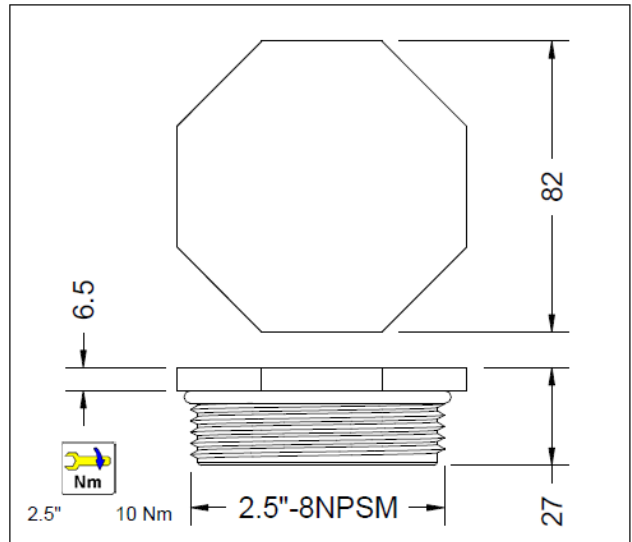
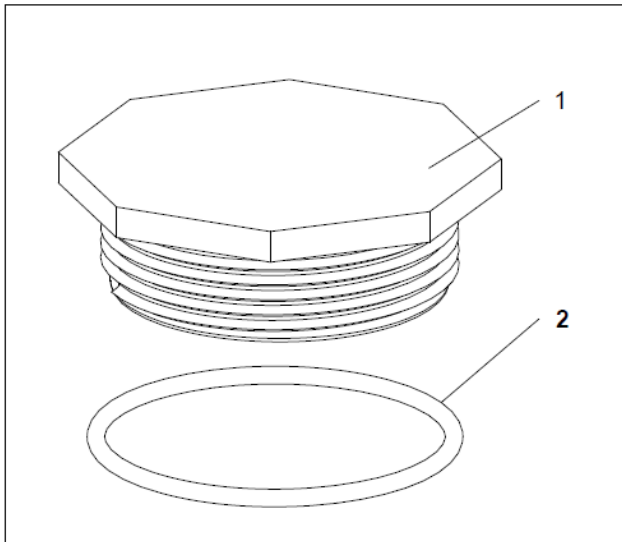
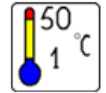
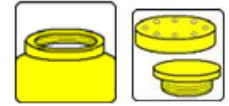

2.5" THREAD





2.5"-8NPSM

Item	Description	Dimensions	Quantity	Material	Part number
1	Closure	2.5" -8NPSM	1	PVC	A-2751-1
2	O-ring	66.27 x 3.53 mm	1	NBR	A-2694-1

A-2751-1C





PENTAIR

CLOSURES & ADAPTER



DN 400

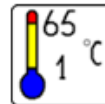
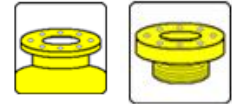

DN400



DN50

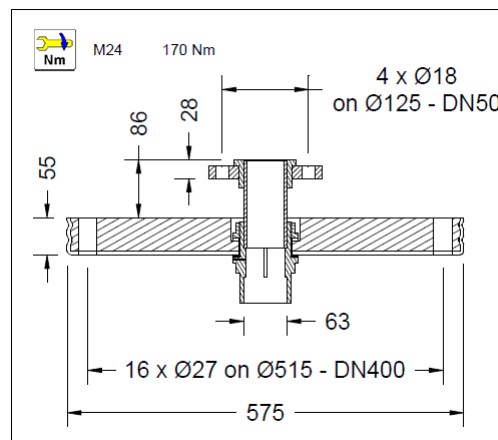
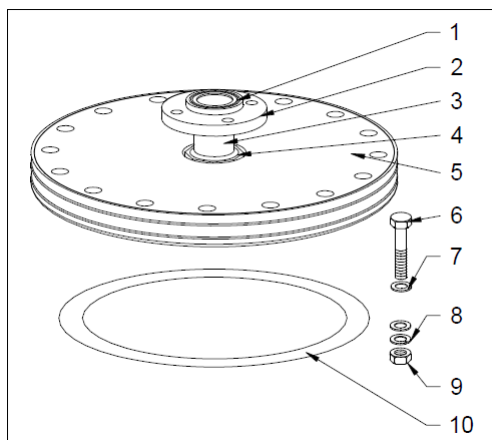

DN400 - DN50

Item	Description	Dimensions	Quantity	Material	Part number
1	Flange Adapter	DN50 - 63 mm	1	PVC	A-3720-64
2	Flange	DN50	1	PP-GF	X-1V-IPN1
3	Pipe	63 - 178 mm	1	PVC	A-PVC-063
4	Table Duct	63 mm	1	PVC	A-5160-65C
5	Flange	DN400	1	LLDPE/GR-EP	A-MACH-DN400
6	Bolt	M24 x 130	16	SS	A-M24-130
7	Washer	M24	32	SS	A-M24-RON
8	Spring Washer	M24	16	SS	A-M24-VRO
9	Nut	M24	16	SS	A-M24-A4
10	Flat Seal	DN400	1	NBR	A-DN40-0D



1

A-3400-02C



PENTAIR

CLOSURES & ADAPTER



4" THREAD

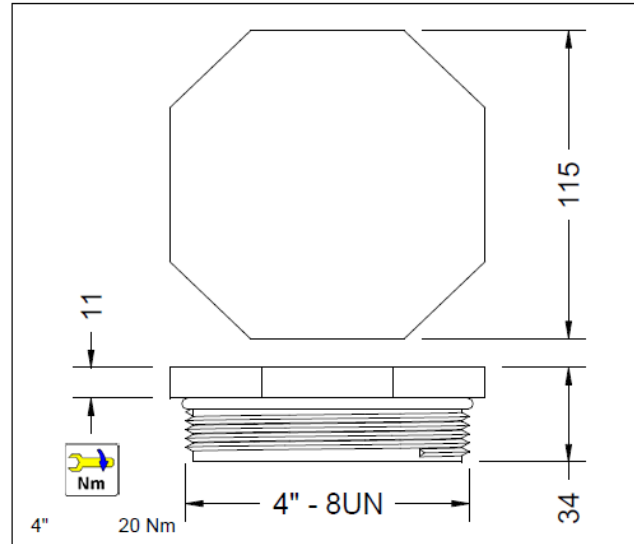
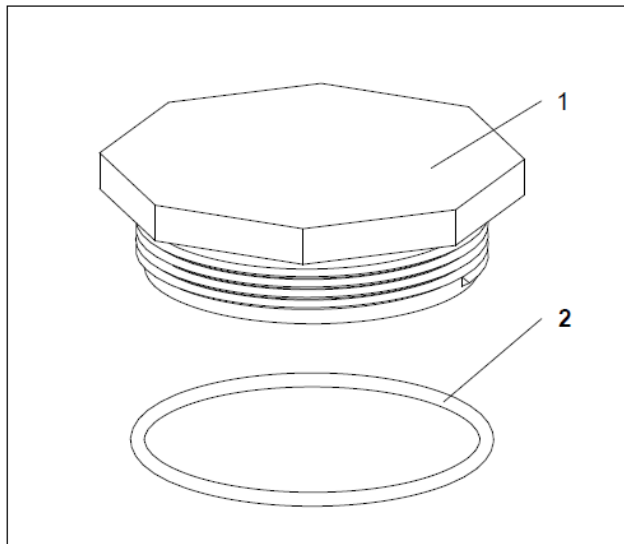
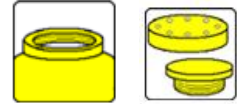

4" - 8 UN

Item	Description	Dimensions	Quantity	Material	Part number
1	Closure	4"-8UN	1	PVC	A-2752-1
2	O-ring	98 x 4 mm	1	NBR	A-2694-3



1



PENTAIR

CLOSURES & ADAPTER



4" THREAD

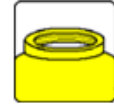

4"-8UN



2 1/2"-8NPSM

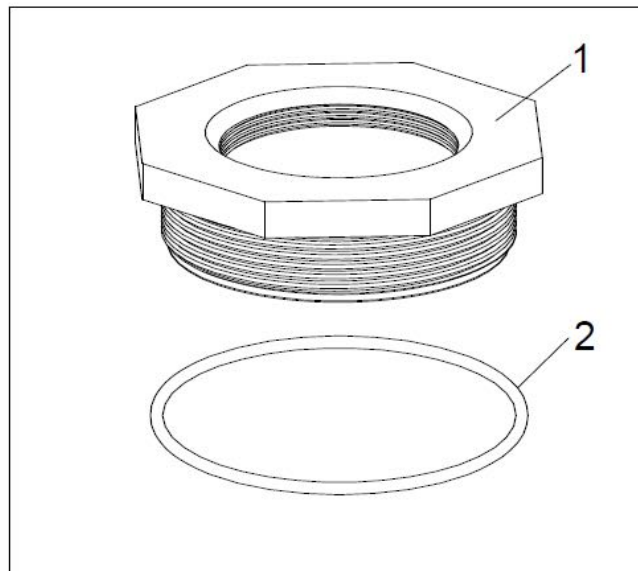

4" 20Nm



4" - 8 UN

Item	Description	Dimensions	Quantity	Material	Part number
1	Closure	4"-8UN	1	PVC	A-2752-2
2	O-ring	98 x 4 mm	1	NBR	A-2694-3
					A-2752-2C



1



PENTAIR

CLOSURES & ADAPTER



6" THREAD

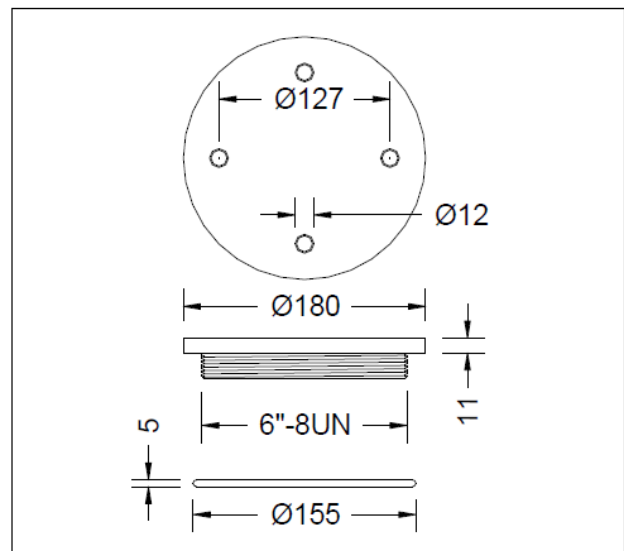
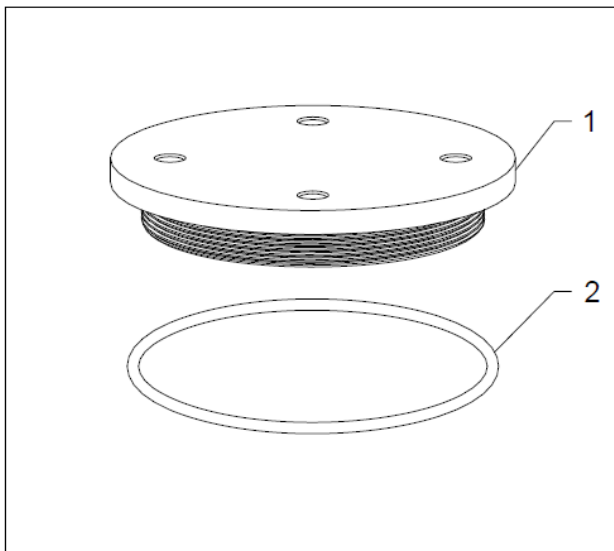
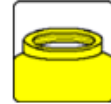

6" - 8 UN

Item	Description	Dimensions	Quantity	Material	Part number
1	Closure	6"-8UN	1	C-PVC	A-2695-3F
2	O-ring	155 x 5 mm	1	NBR	A-2694-BF
					A-2695-3FC



1



PENTAIR

CLOSURES & ADAPTER



6" FLANGE

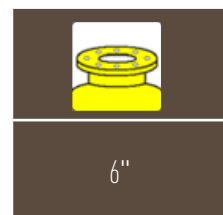
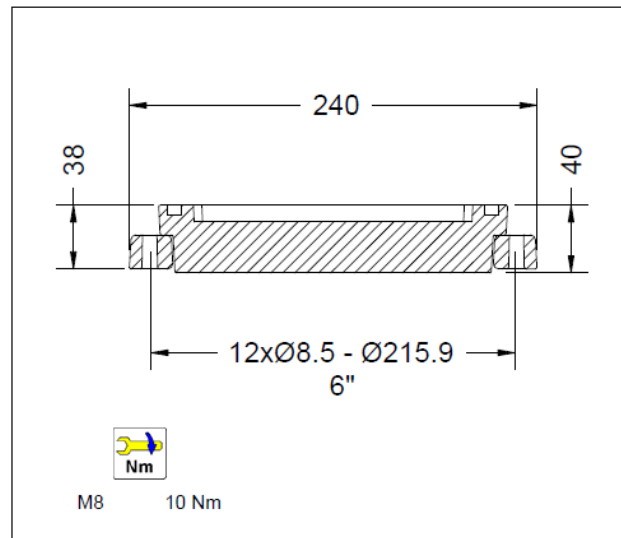
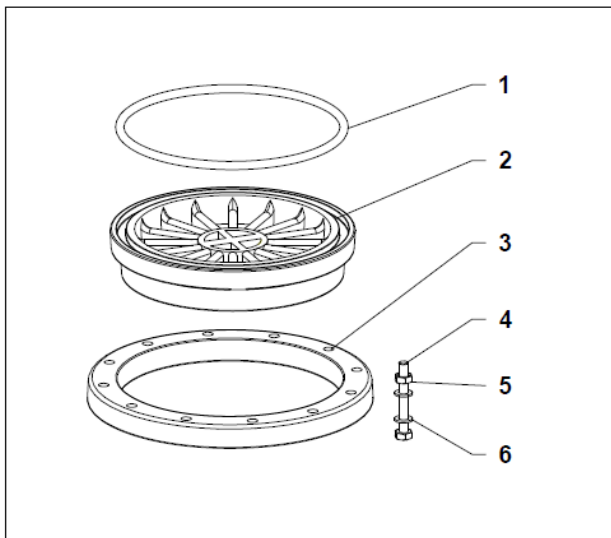
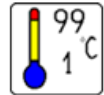
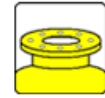

6"

Item	Description	Dimensions	Quantity	Material	Part number
1	O-ring	183.52 x 6.99 mm	1	NBR	A-2694-8F
2	Closure	6"	1	PPO	A-085-0006
3	Backing Flange	6"	1	PPO	A-085-0221
4	Bolt	M8 x 75	12	SS	A-M8-075
5	Nut	M8	12	SS	A-M8-A4
6	Washer	M8	24	SS	A-M8-RON



A-3100-01C

1







PENTAIR

CLOSURES & ADAPTER

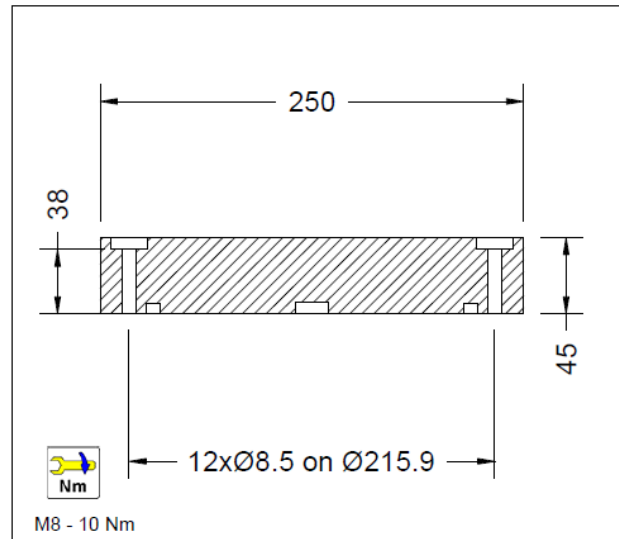
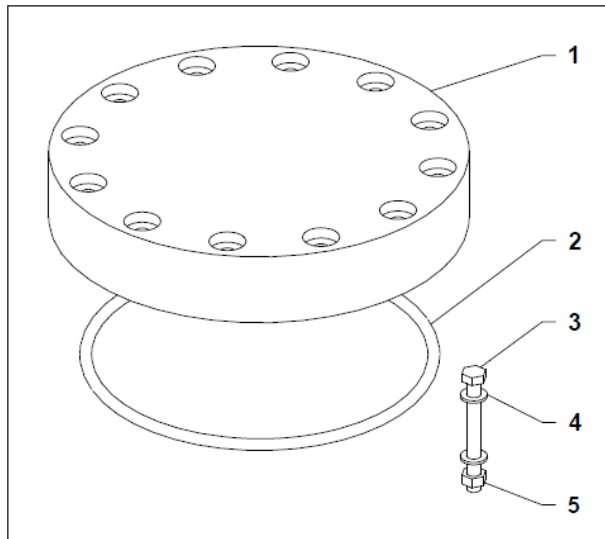
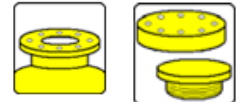

6" FLANGE



	 HDPE	 PVDF
	 50 1 °C	 99 1 °C
A-3100-ALC	A1-3100-ALC	A1-3100-ALC

Item	Description	Dimensions	Quantity	Material	Part number
1	Closure	6"	1		A-3100-01AL A1-3100-01AL
2	O-ring	183.52 x 6.99 mm	1	FPM	A-2694-V8F A-2694-V8F
3	Bolt	M8 x 75	12	SS	A-8894-00 A-8894-00
4	Washer	M8	24	SS	A-M8-RON A-M8-RON
5	Nut	M8	12	SS	A-M8-A4 A-M8-A4





PENTAIR

CLOSURES & ADAPTER



6" FLANGE



6" FLANGE
1.5" BSP



1.5" BSP

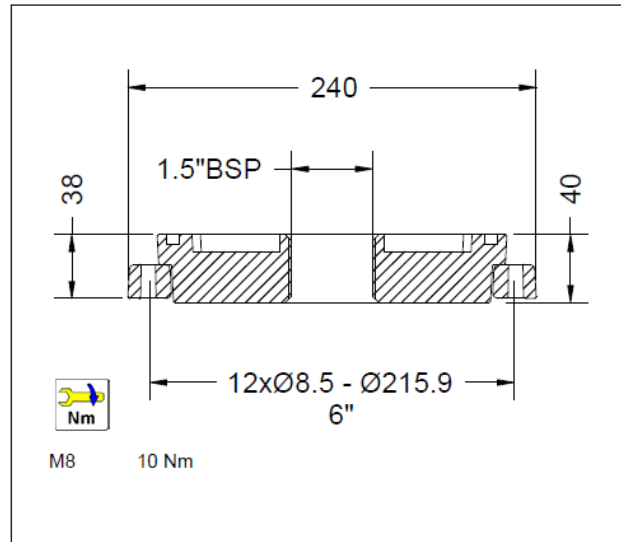
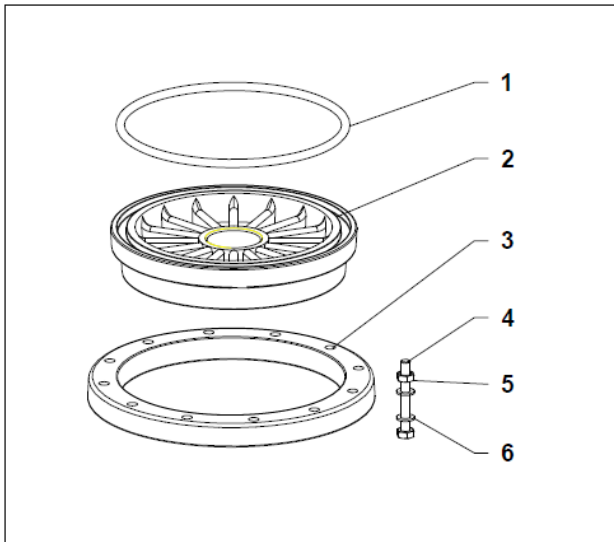

6" - 1.5" BSP

Item	Description	Dimensions	Quantity	Material	Part number
1	O-ring	183.52 x 6.99 mm	1	NBR	A-2694-8F
2	Adapter	6" - 1.5"BSP	1	PPO	A-085-0007
3	Backing Flange	6"	1	PPO	A-085-0221
4	Bolt	M8 x 75	12	SS	A-M8-075
5	Nut	M8	12	SS	A-M8-A4
6	Washer	M8	24	SS	A-M8-RON



1

A-3100-06C



PENTAIR

CLOSURES & ADAPTER



6" FLANGE

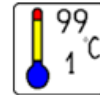
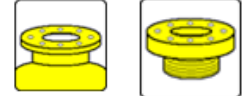

6" FLANGE
2.5"-8 NPSM



2.5" 8 NPSM

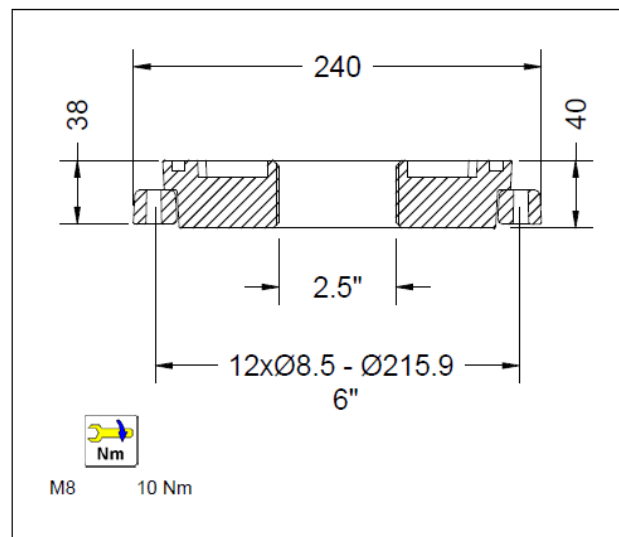
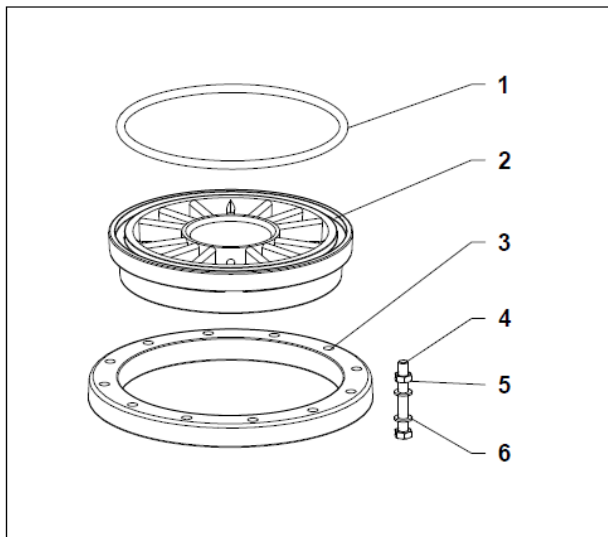

6" - 2.5"

Item	Description	Dimensions	Quantity	Material	Part number
1	O-ring	183.52 x 6.99 mm	1	NBR	A-2694-8F
2	Adapter	6" - 2.5"	1	PPO	A-085-0009
3	Backing Flange	6"	1	PPO	A-085-0221
4	Bolt	M8 x 75	12	SS	A-M8-075
5	Nut	M8	12	SS	A-M8-A4
6	Washer	M8	24	SS	A-M8-RON

A-3100-07C



1



PENTAIR

CLOSURES & ADAPTER



6" FLANGE

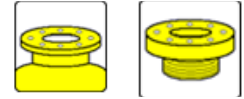

6" FLANGE
4" - 8 UN



4" - 8 UN

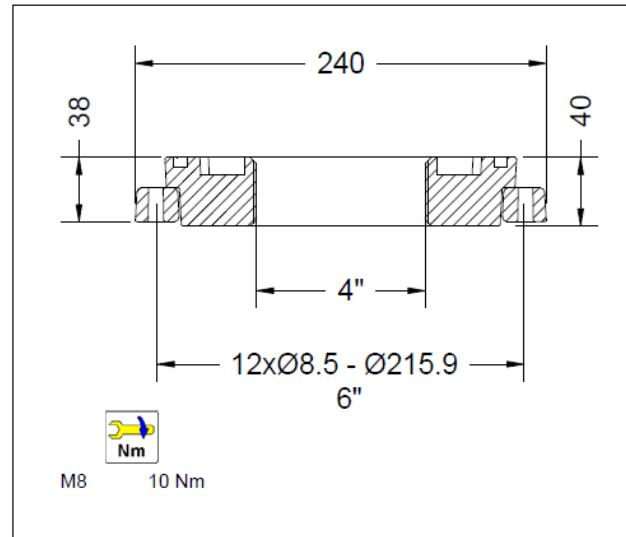
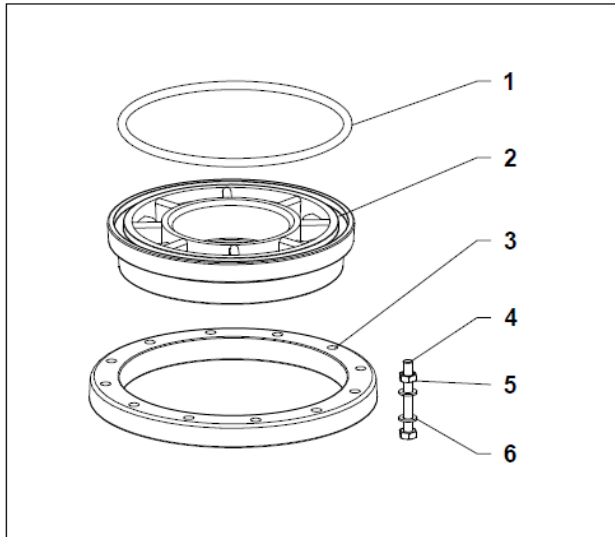

M8 10 Nm

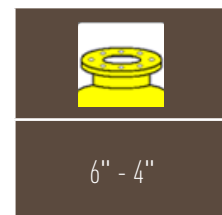

Item	Description	Dimensions	Quantity	Material	Part number
1	O-ring	183.52 x 6.99 mm	1	NBR	A-2694-8F
2	Adapter	6" - 4"	1	PPO	A-085-0101
3	Backing Flange	6"	1	PPO	A-085-0221
4	Bolt	M8 x 75	12	SS	A-M8-075
5	Nut	M8	12	SS	A-M8-A4
6	Washer	M8	24	SS	A-M8-RON



1

A-3100-08C



PENTAIR

CLOSURES & ADAPTER



6" FLANGE

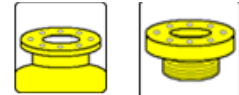

6" FLANGE
2.5" - 8 UN



DN 65

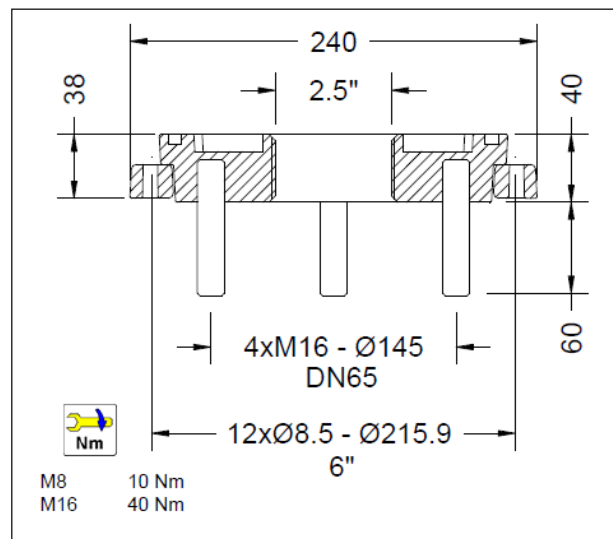
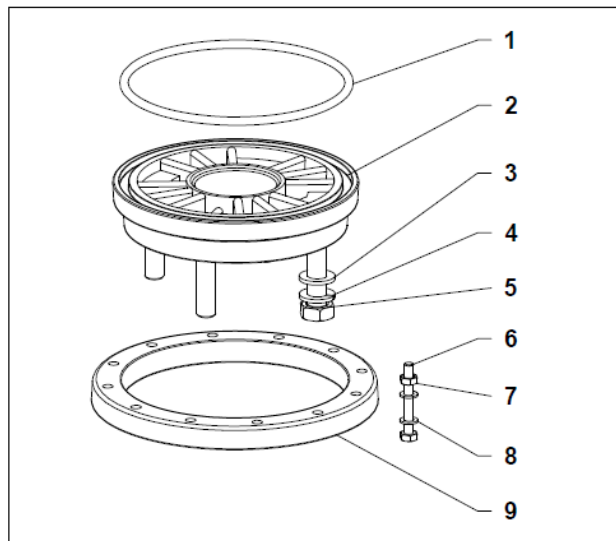

6" - DN65 - 2.5"

Item	Description	Dimensions	Quantity	Material	Part number
1	O-ring	183.52 x 6.99 mm	1	NBR	A-2694-8F
2	Adapter	6" - DN65	1	PPO	A-086-0000
3	Washer	M16	4	SS	A-M16-RON
4	Spring Washer	M16	4	SS	A-M16-VRO
5	Nut	M16	4	SS	A-M16-A4
6	Bolt	M8 x 75	12	SS	A-M8-075
7	Nut	M8	12	SS	A-M8-A4
8	Washer	M8	24	SS	A-M8-RON
9	Backing Flange	6"	1	PPO	A-085-0221



1

A-3100-02C



PENTAIR

CLOSURES & ADAPTER



6" FLANGE

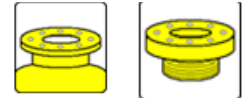

6" FLANGE
4" - 8 UN



DN 80

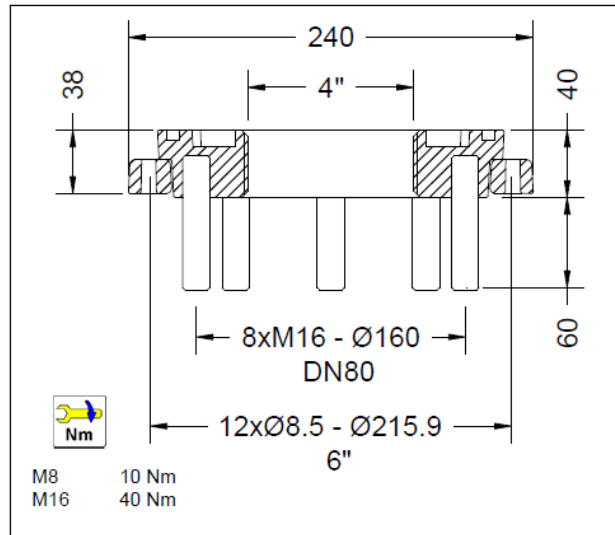
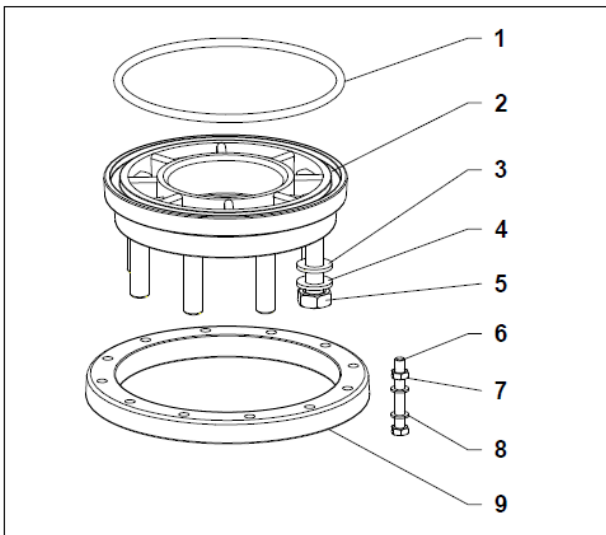

Item	Description	Dimensions	Quantity	Material	Part number
1	O-ring	183.52 x 6.99 mm	1	NBR	A-2694-8F
2	Adapter	6" - DN80	1	PPO	A-086-0003
3	Washer	M16	8	SS	A-M16-RON
4	Spring Washer	M16	8	SS	A-M16-VRO
5	Nut	M16	8	SS	A-M16-A4
6	Bolt	M8 x 75	12	SS	A-M8-075
7	Nut	M8	12	SS	A-M8-A4
8	Washer	M8	24	SS	A-M8-RON
9	Backing Flange	6"	1	PPO	A-085-0221



A-3100-03C

1



PENTAIR

CLOSURES & ADAPTER



6" FLANGE

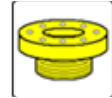
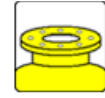

6" FLANGE
4" - 8 UN



DN 100

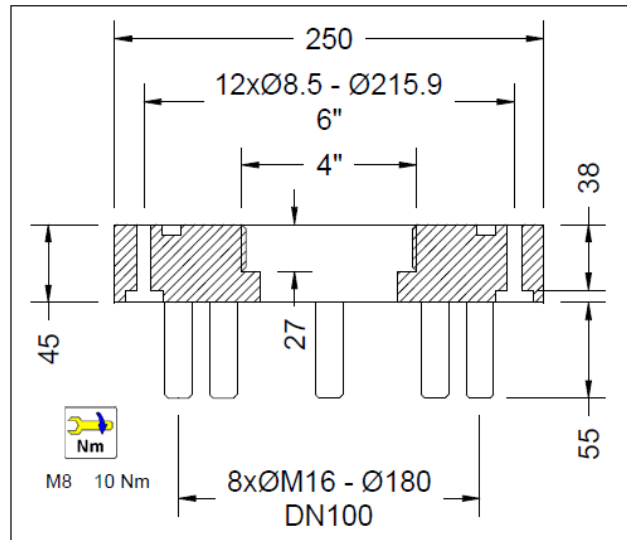
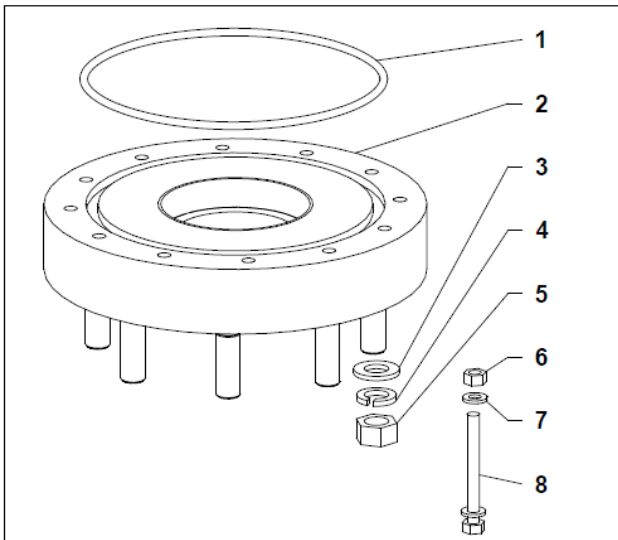

Item	Description	Dimensions	Quantity	Material	Part number
1	O-ring	183.52 x 6.99 mm	1	NBR	A-2694-8F
2	Adapter	6" - DN100	1	PPO	A-3100-100
3	Washer	M16	8	SS	A-M16-RON
4	Spring Washer	M16	8	SS	A-M16-VR0
5	Nut	M16	8	SS	A-M16-A4
6	Nut	M8	12	SS	A-M8-A4
7	Washer	M8	24	SS	A-M8-RON
8	Bolt	M8	12	SS	A-M8-075



1

A-3100-09C



PENTAIR

CLOSURES & ADAPTER



BLINDFLANGE

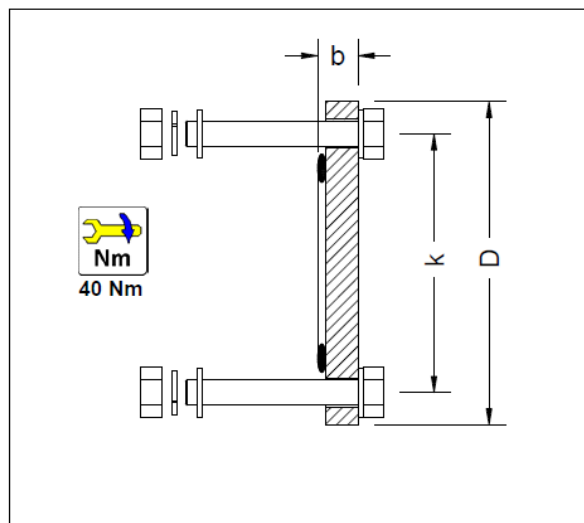
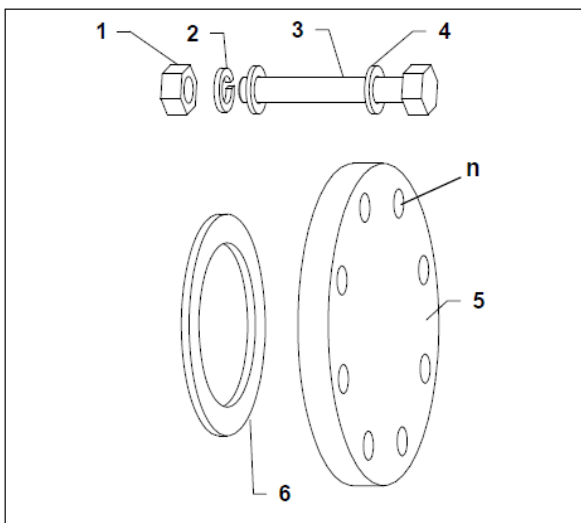
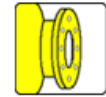

Item	Description	Material	DN50	DN80	DN100	DN200
1	Nut	SS	A-M16-A4	A-M16-A4	A-M16-A4	A-M20-A4
2	Spring Washer	SS	A-M16-VRO	A-M16-VRO	A-M16-VRO	A-M20-VRO
3	Bolt	SS	A-M16-90	A-M16-90	A-M16-90	A-M20-120
4	Washer	SS	A-M16-RON	A-M16-RON	A-M16-RON	A-M20-RON
5	Blind Flange	PP-GF/PVC	AG-DN-50B	AG-DN-80B	AG-DN-10B	A6-DN20-PPGF
6	Seal	NBR	A-2600-68	A-2600-71	A-2600-67	A-DN20-0D
			4	8	8	8
			19	19	20	46
			145	160	180	295
			185	200	220	340
			AG-DN-50L	AG-DN-80L	AG-DN-10L	A-3200-01C





PENTAIR

CLOSURES & ADAPTER



BLINDFLANGE

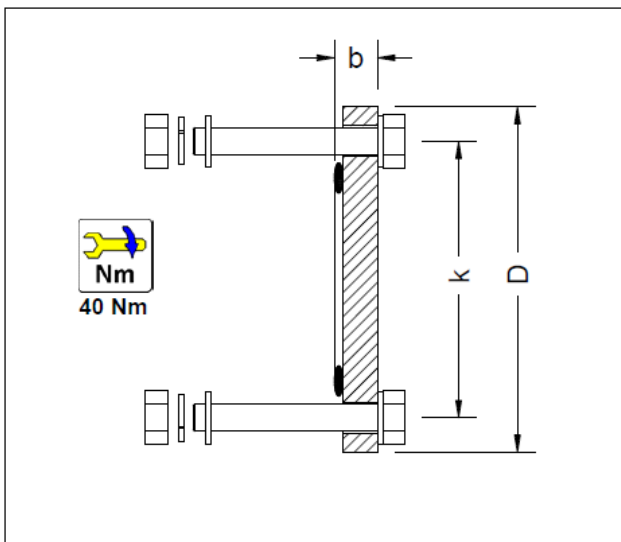
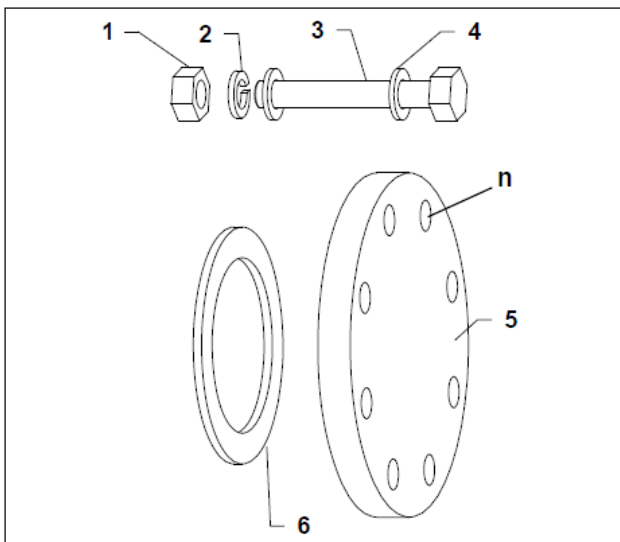
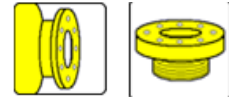

Item	Description	Material	DN50	DN80	DN100	DN200
1	Nut	SS	A-M16-A4	A-M16-A4	A-M16-A4	A-M20-A4
2	Spring Washer	SS	A-M16-VRO	A-M16-VRO	A-M16-VRO	A-M20-VRO
3	Bolt	SS	A-M16-90	A-M16-90	A-M16-90	A-M20-120
4	Washer	SS	A-M16-RON	A-M16-RON	A-M16-RON	A-M20-RON
5	Blind Flange	PP-GF/PVC	AG-DN-50B	AG-DN-80B	AG-DN-10B	A-3742-00
6	Seal	NBR	A-2600-68	A-2600-71	A-2600-67	A-DN20-0D
			4	8	8	8
			19	19	20	46
			145	160	180	295
			185	200	220	340
			AG-DN-50L	AG-DN-80L	AG-DN-10L	A-3200-01C





PENTAIR

CLOSURES & ADAPTER



BLINDFLANGE

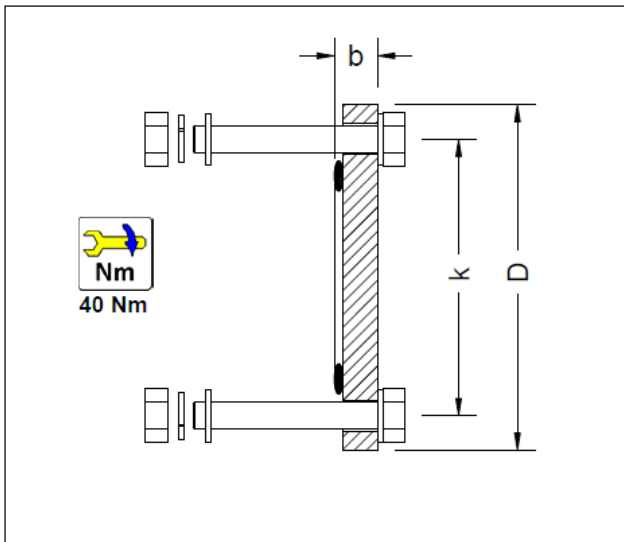
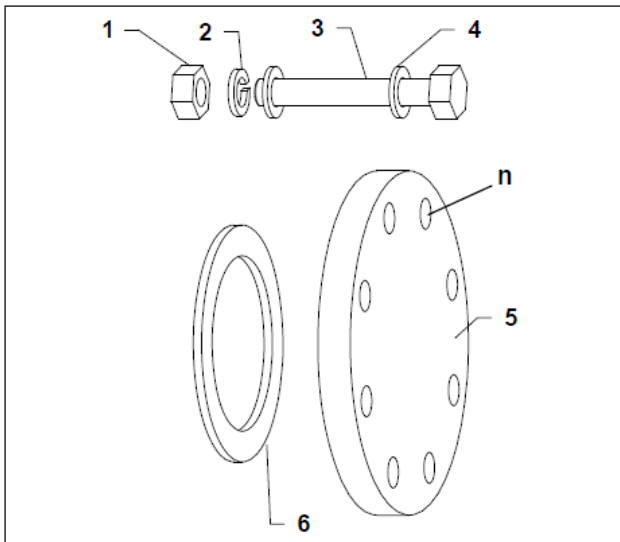
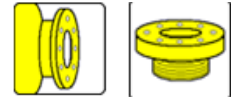

Item	Description	Material	DN50	DN80	DN100	DN200
1	Nut	SS	A-M16-A4	A-M16-A4	A-M16-A4	A-M20-A4
2	Spring Washer	SS	A-M16-VRO	A-M16-VRO	A-M16-VRO	A-M20-VRO
3	Bolt	SS	A-M16-90	A-M16-90	A-M16-90	A-M20-120
4	Washer	SS	A-M16-RON	A-M16-RON	A-M16-RON	A-M20-RON
5	Blind Flange	PP-GF/PVC	AG-DN-50B	AG-DN-80B	AG-DN-10B	A-3742-00
6	Seal	NBR	A-2600-68	A-2600-71	A-2600-67	A-DN20-0D
			4	8	8	8
			19	19	20	46
			145	160	180	295
			185	200	220	340
			AG-DN-50L	AG-DN-80L	AG-DN-10L	A-3200-01C





PENTAIR

CLOSURES & ADAPTER



BLINDFLANGE

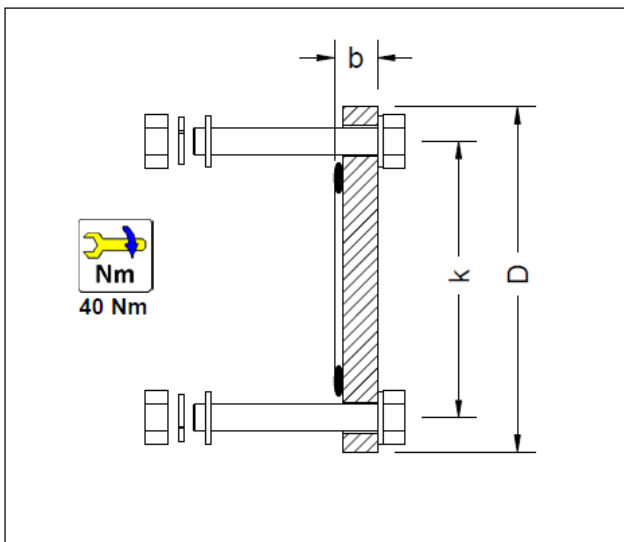
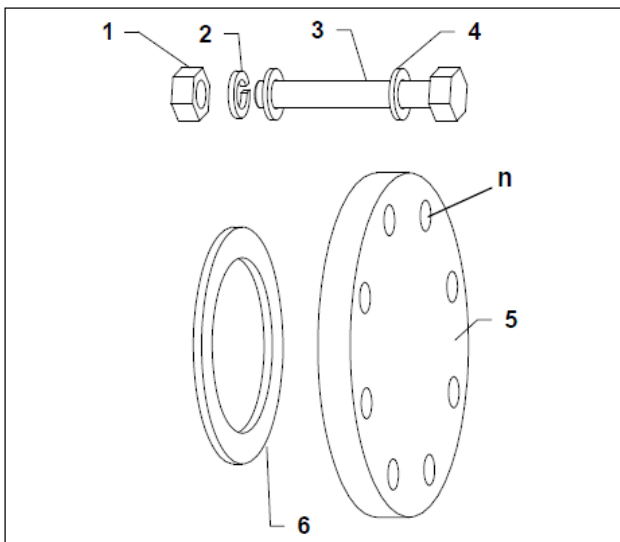
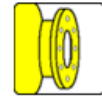

Item	Description	Material	DN50	DN80	DN100	DN200
1	Nut	SS	A-M16-A4	A-M16-A4	A-M16-A4	A-M20-A4
2	Spring Washer	SS	A-M16-VRO	A-M16-VRO	A-M16-VRO	A-M20-VRO
3	Bolt	SS	A-M16-90	A-M16-90	A-M16-90	A-M20-120
4	Washer	SS	A-M16-RON	A-M16-RON	A-M16-RON	A-M20-RON
5	Blind Flange	PP-GF/PVC	AG-DN-50B	AG-DN-80B	AG-DN-10B	A-3742-00
6	Seal	NBR	A-2600-68	A-2600-71	A-2600-67	A-DN20-0D
			4	8	8	8
			19	19	20	46
			145	160	180	295
			185	200	220	340
			AG-DN-50L	AG-DN-80L	AG-DN-10L	A-3200-01C





PENTAIR

CLOSURES & ADAPTER



BLINDFLANGE

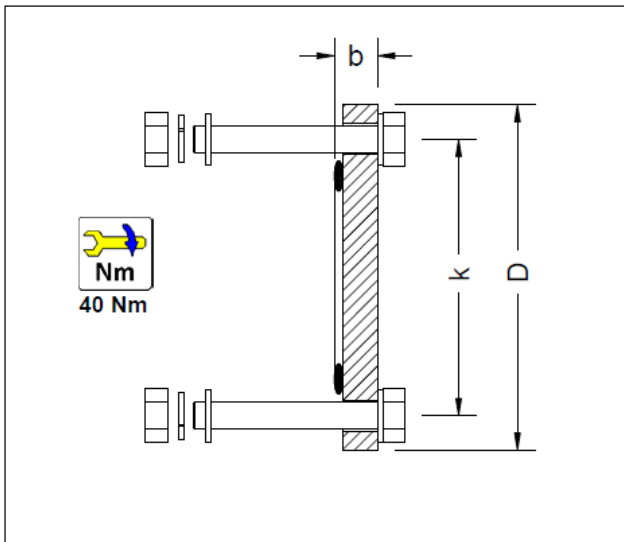
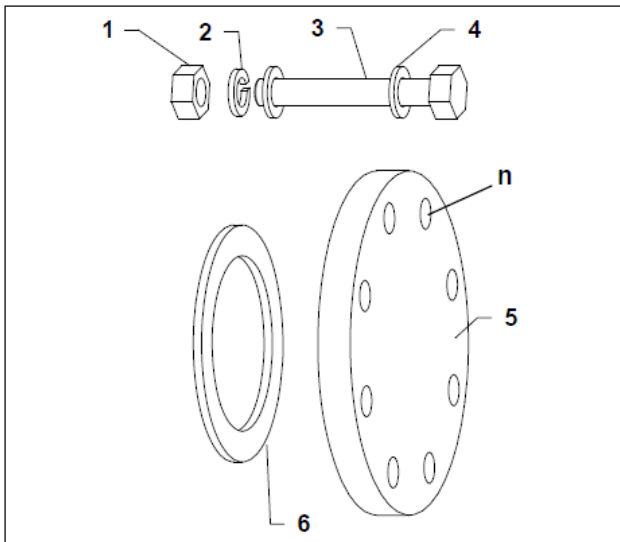
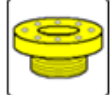
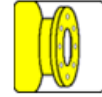

Item	Description	Material	DN50	DN80	DN100	DN200
1	Nut	SS	A-M16-A4	A-M16-A4	A-M16-A4	A-M20-A4
2	Spring Washer	SS	A-M16-VRO	A-M16-VRO	A-M16-VRO	A-M20-VRO
3	Bolt	SS	A-M16-90	A-M16-90	A-M16-90	A-M20-120
4	Washer	SS	A-M16-RON	A-M16-RON	A-M16-RON	A-M20-RON
5	Blind Flange	PP-GF/PVC	AG-DN-50B	AG-DN-80B	AG-DN-10B	A-3742-00
6	Seal	NBR	A-2600-68	A-2600-71	A-2600-67	A-DN20-0D
			4	8	8	8
			19	19	20	46
			145	160	180	295
			185	200	220	340
			AG-DN-50L	AG-DN-80L	AG-DN-10L	A-3200-01C





PENTAIR

CLOSURES & ADAPTER



BLINDFLANGE

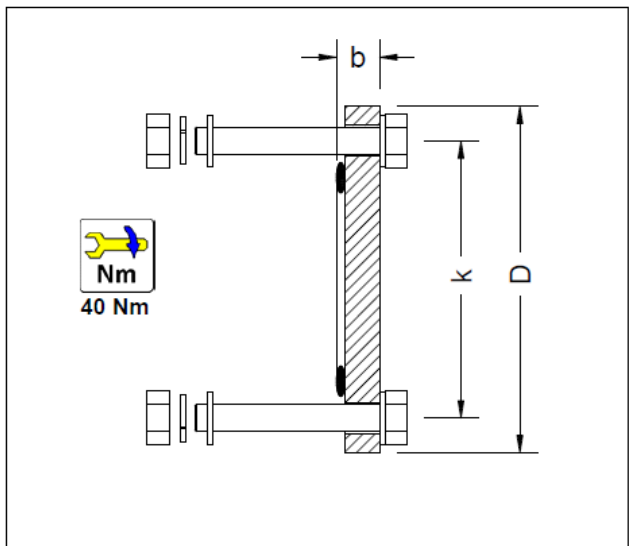
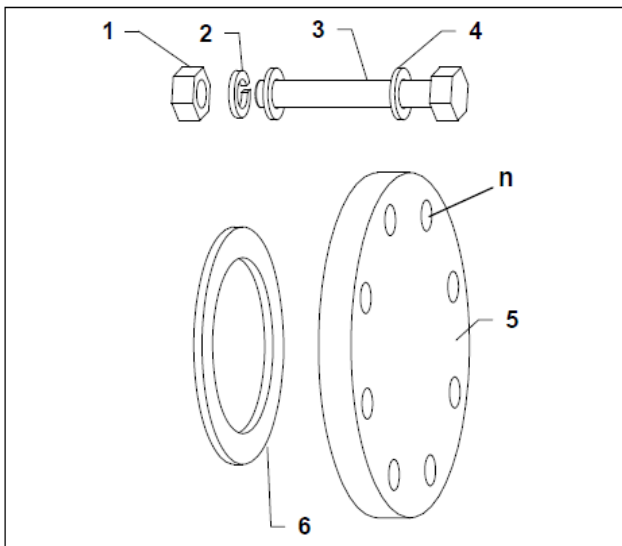
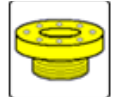
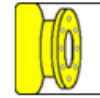

Item	Description	Material	DN50	DN80	DN100	DN200
1	Nut	SS	A-M16-A4	A-M16-A4	A-M16-A4	A-M20-A4
2	Spring Washer	SS	A-M16-VRO	A-M16-VRO	A-M16-VRO	A-M20-VRO
3	Bolt	SS	A-M16-90	A-M16-90	A-M16-90	A-M20-120
4	Washer	SS	A-M16-RON	A-M16-RON	A-M16-RON	A-M20-RON
5	Blind Flange	PP-GF	AG-DN-50B	AG-DN-80B	AG-DN-10B	AG-DN-20PPGF
6	Seal	NBR	A-2600-68	A-2600-71	A-2600-67	A-DN20-0D
			4	8	8	8
			19	19	20	41
			145	160	180	295
			185	200	220	340
			AG-DN-50L	AG-DN-80L	AG-DN-10L	A-3200-02C





PENTAIR

CLOSURES & ADAPTER



BLINDFLANGE

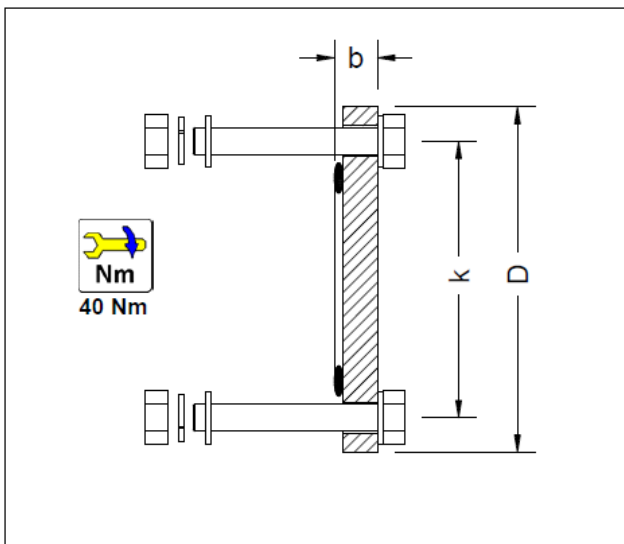
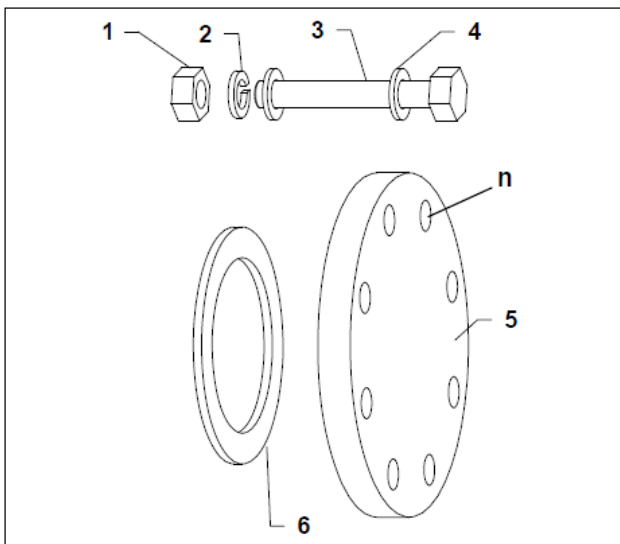
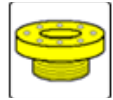
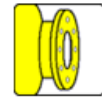

Item	Description	Material	DN50	DN80	DN100	DN200
1	Nut	SS	A-M16-A4	A-M16-A4	A-M16-A4	A-M20-A4
2	Spring Washer	SS	A-M16-VRO	A-M16-VRO	A-M16-VRO	A-M20-VRO
3	Bolt	SS	A-M16-90	A-M16-90	A-M16-90	A-M20-120
4	Washer	SS	A-M16-RON	A-M16-RON	A-M16-RON	A-M20-RON
5	Blind Flange	PP-GF/PVC	AG-DN-50B	AG-DN-80B	AG-DN-10B	A-3742-00
6	Seal	NBR	A-2600-68	A-2600-71	A-2600-67	A-DN20-0D
			4	8	8	8
			19	19	20	46
			145	160	180	295
			185	200	220	340
			AG-DN-50L	AG-DN-80L	AG-DN-10L	A-3200-01C



1



PENTAIR

CLOSURES & ADAPTER



BLINDFLANGE

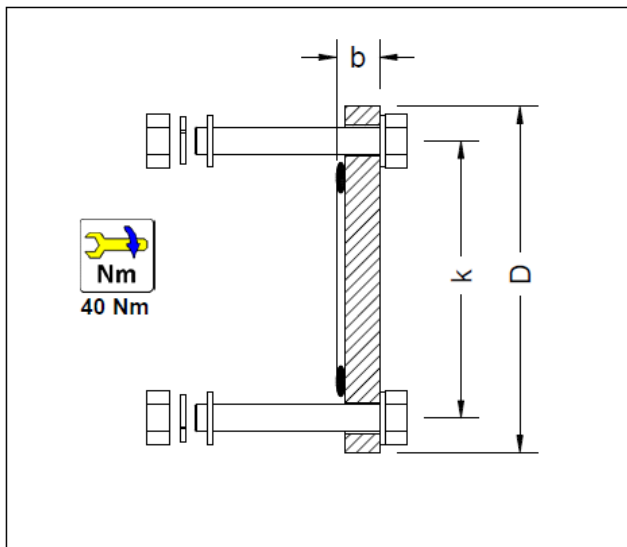
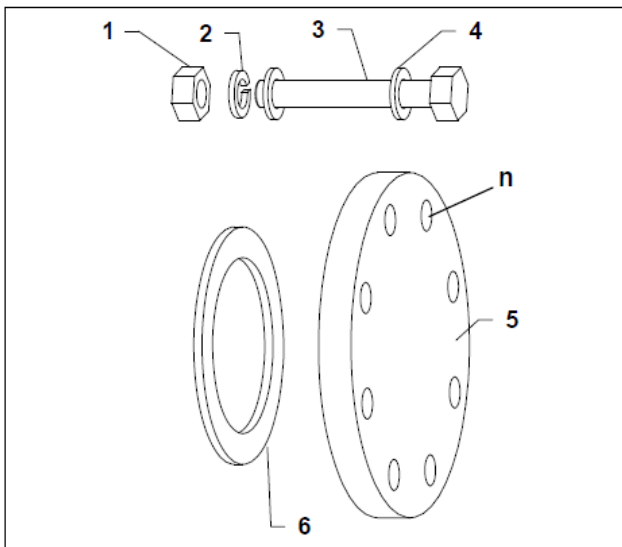
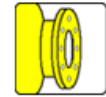

Item	Description	Material	DN50	DN80	DN100	DN200
1	Nut	SS	A-M16-A4	A-M16-A4	A-M16-A4	A-M20-A4
2	Spring Washer	SS	A-M16-VRO	A-M16-VRO	A-M16-VRO	A-M20-VRO
3	Bolt	SS	A-M16-90	A-M16-90	A-M16-90	A-M20-120
4	Washer	SS	A-M16-RON	A-M16-RON	A-M16-RON	A-M20-RON
5	Blind Flange	PP-GF	AG-DN-50B	AG-DN-80B	AG-DN-10B	AG-DN-20PPGF
6	Seal	NBR	A-2600-68	A-2600-71	A-2600-67	A-DN20-0D
			4	8	8	8
			19	19	20	41
			145	160	180	295
			185	200	220	340
			AG-DN-50L	AG-DN-80L	AG-DN-10L	A-3200-02C



1



PENTAIR

DRAIN INSERTS



6" FLANGE

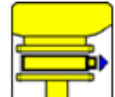

DRAIN

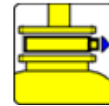
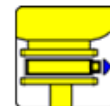
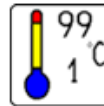

1" BSP

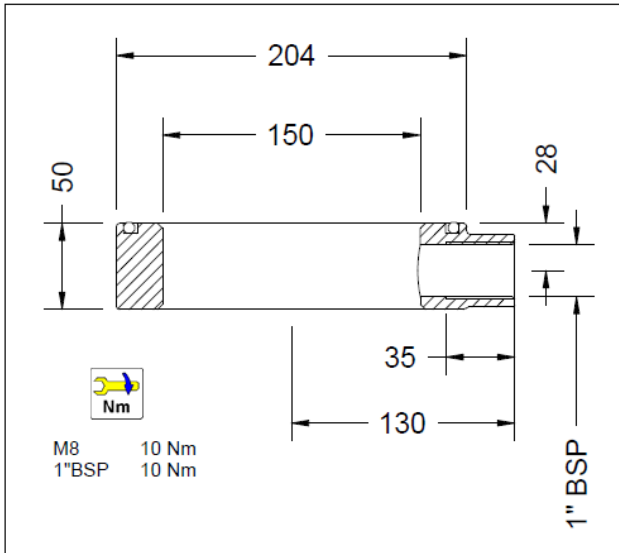
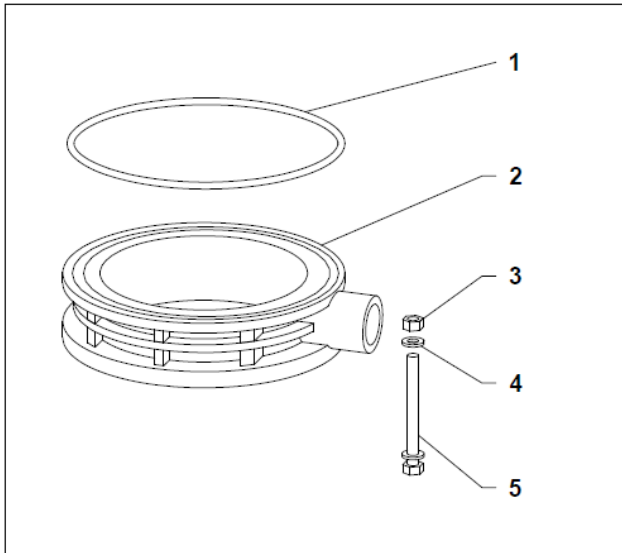

M8 10 Nm
1" BSP 10 Nm

1" BSP

A-DRAIN-1BSP

Item	Description	Dimensions	Quantity	Material	Part number
1	O-ring	183.52 x 6.99 mm	1	NBR	A-2694-8F
2	Drain insert	6" - 1" BSP	1	PPO	A-085-0002
3	Nut	M8	12	SS	A-M8-A4
4	Washer	M8	24	SS	A-M8-RON
5	Bolt	M8 x 120	12	SS	A-M8-120

1



PENTAIR

DRAIN INSERTS



6" FLANGE

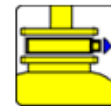
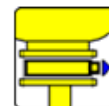
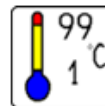
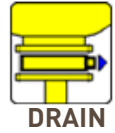
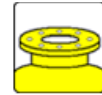

1" BSP

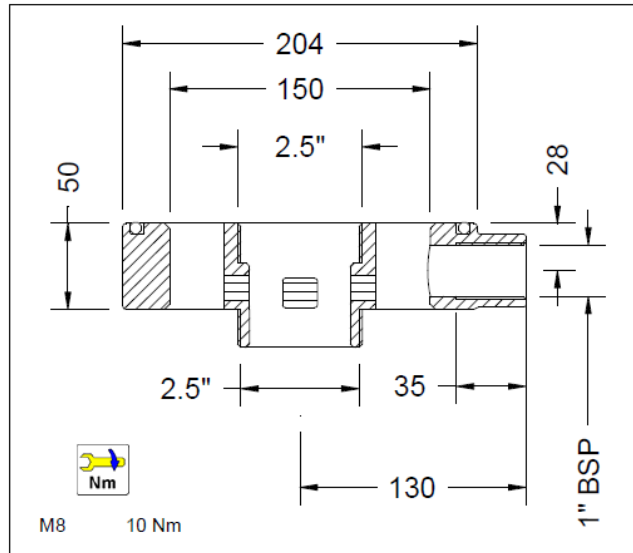
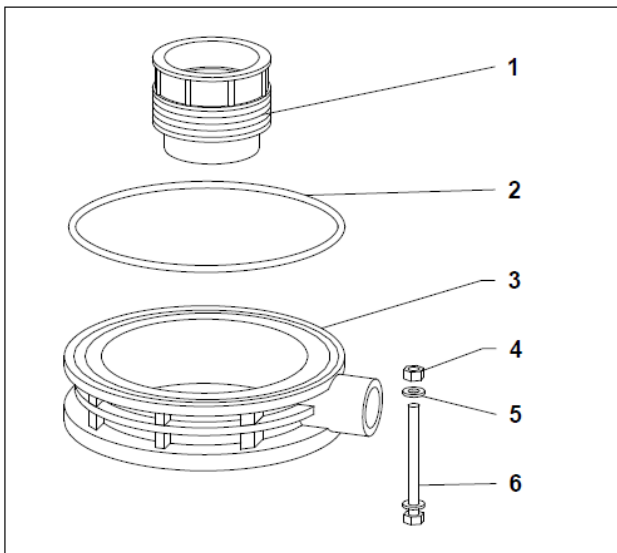

1" BSP
2.5"

Item	Description	Dimensions	Quantity	Material	Part number
1	Prolongation	2.5" - 50mm	1	PPO	A-3100-04C
2	O-ring	183.52 x 6.99 mm	1	NBR	A-2694-8F
3	Drain insert	6"-1"BSP	1	PPO	A-085-0002
4	Nut	M8	12	SS	A-M8-A4
5	Washer	M8	24	SS	A-M8-RON
6	Bolt	M8 x 120	12	SS	A-M8-120



1

A-DRAIN-LF



PENTAIR

DRAIN INSERTS



6" FLANGE

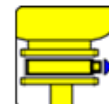
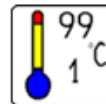
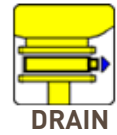
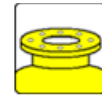

1" BSP

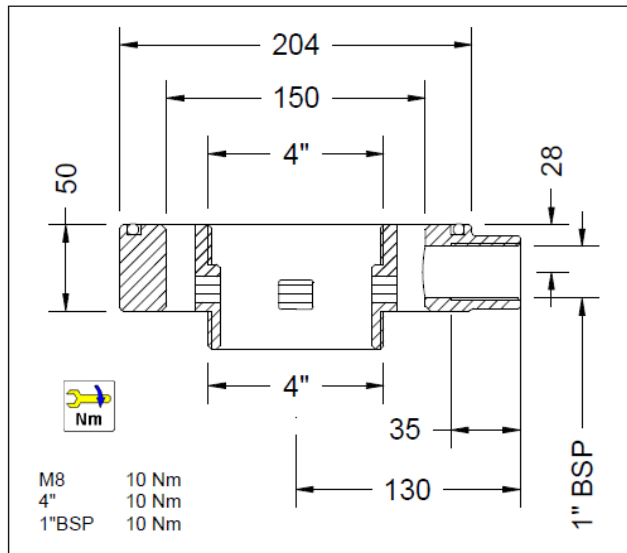
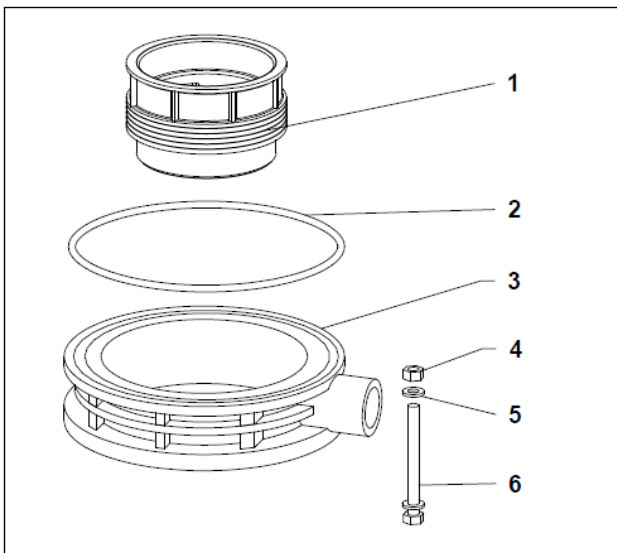

 Nm
 M8 10 Nm
 4" 10 Nm
 1" BSP 10 Nm



1" BSP
4"

Item	Description	Dimensions	Quantity	Material	Part number
1	Prolongation	4" – 50mm	1	PPO	A-3100-05C
2	O-ring	183.52 x 6.99 mm	1	NBR	A-2694-8F
3	Drain insert	6"-1" BSP	1	PPO	A-085-0002
4	Nut	M8	12	SS	A-M8-A4
5	Washer	M8	24	SS	A-M8-RON
6	Bolt	M8 x 120	12	SS	A-M8-120



1

A-DRAIN-HF

PENTAIR SIGHT GLASS



SIGHTGLASS

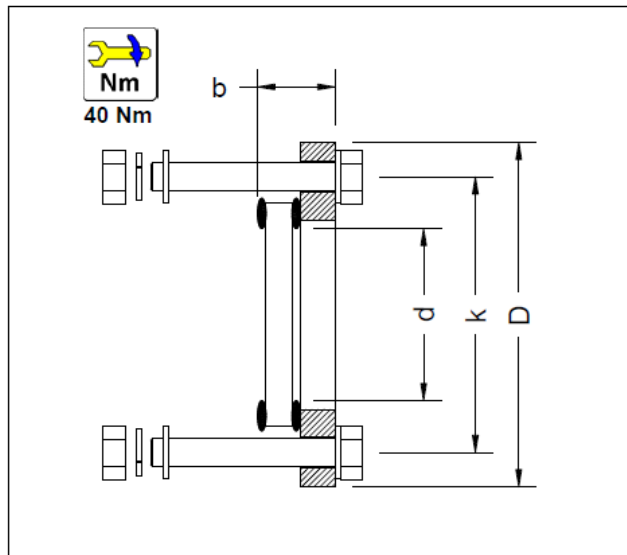
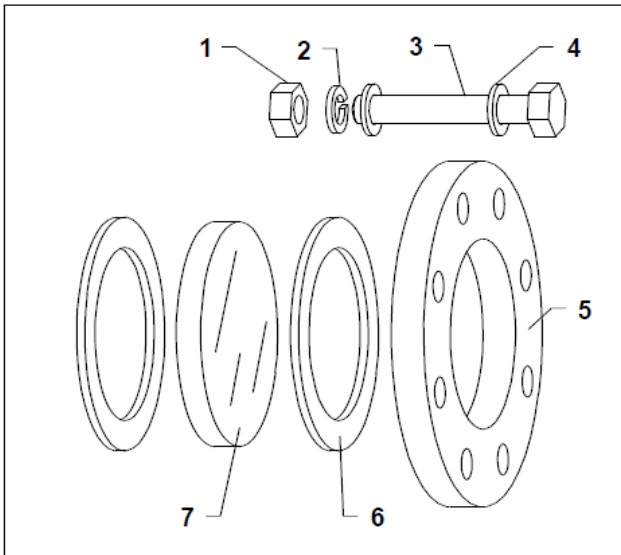
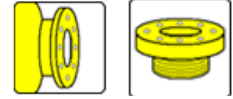

Item	Description	Quantity	Material	Part number	
				DN80	DN100
1	Nut	8	SS	A-M16-A4	A-M16-A4
2	Spring Water	8	SS	A-M16-VRO	A-M16-VRO
3	Bolt	8	SS	A-M16-110	A-M16-110
4	Washer	16	SS	A-M16-RON	A-M16-RON
5	Backing Flange	1	PP-GF	X-1V-IP80	X-0D-N101
6	Seal	1	NBR	A-2600-71	A-2600-67
7	Sightglass	1	GLASS	A-KIJK-80	A-KIJK-100
				45	45
				100	115
				200	220
				160	180
				A-SGHT-DN80	A-SGHT-DN100



1



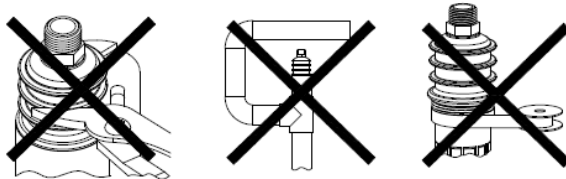
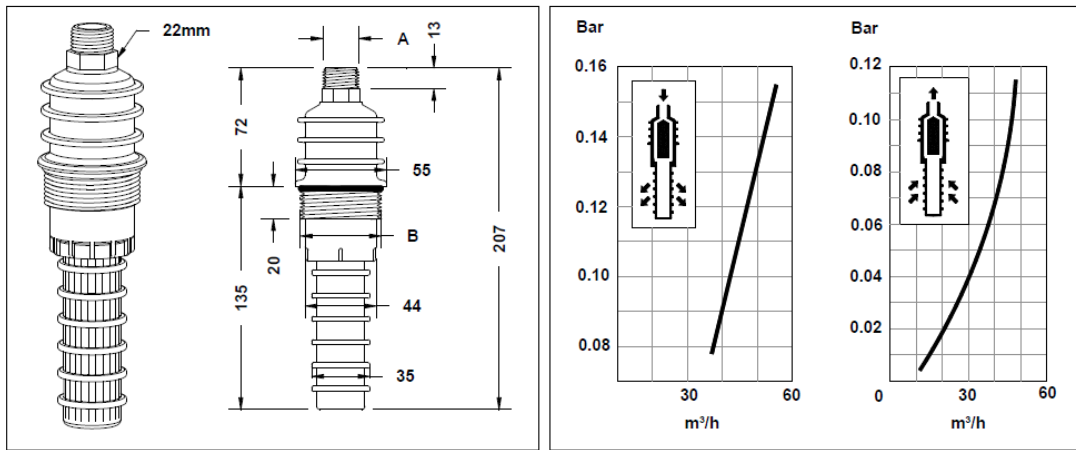

AERATION VALVE

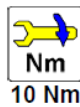
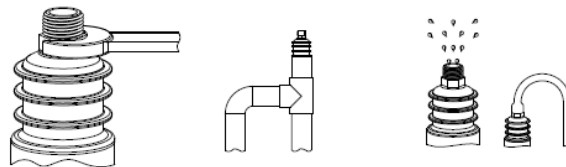

AERATION VALVE



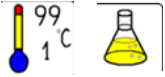

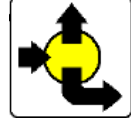
Item	Thread A	Thread B	Material	 1
	1/2" BSP	1 1/2" BSP	PP-GF/EPDM	A-AV-150PP
	1/2" NPT	1 1/2" NPT	PP-GF/EPDM	
	1/2" BSP	1 1/2" BSP	PVDF/FPM	A-AV-150PVDF
	1/2" NPT	1 1/2" NPT	PVDF/FPM	

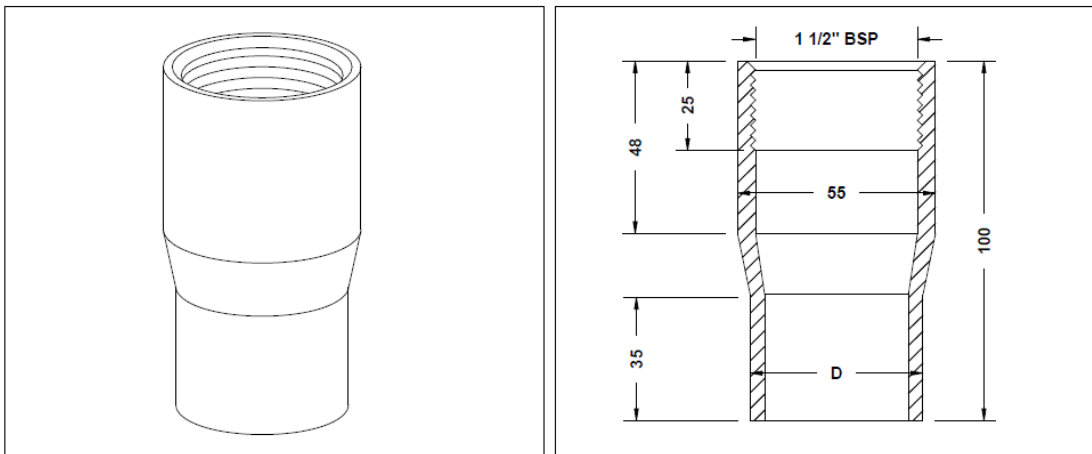

AERATION VALVE



ADAPTER FOR AERATION VALVE

D		Description	Material	 1
48mm		1 1/2" BSP - 48 mm	PVC	A-AV-AD48
50mm		1 1/2" BSP - 50 mm	PVC	A-AV-AD50



2.5" VALVE

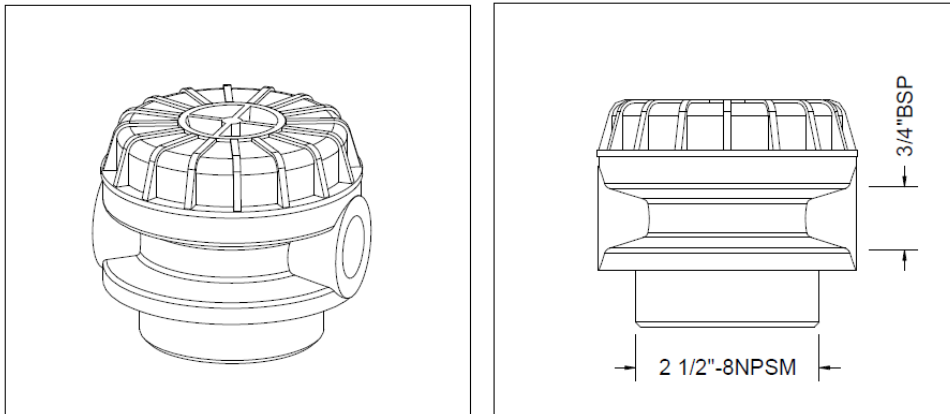

MANUAL VALVE

Type	Thread A	Thread B	Material	 1
	2.5" - 8 NPSM	3/4" BSP	PP	A-ANA-25-G3/4



WRENCHES

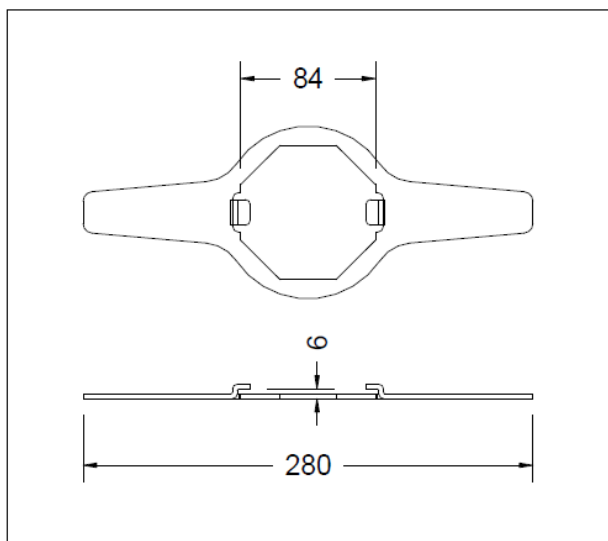
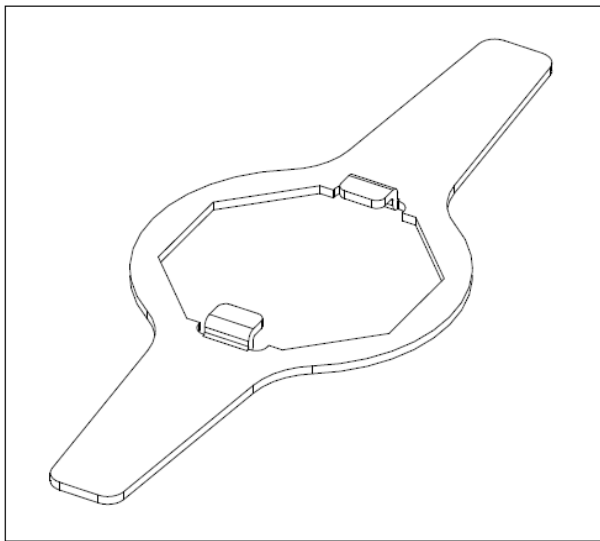

OCTOGONAL WRENCH FOR ADAPTERS
2.5" - 84 MM



Item	Description	Dimensions	Quantity	Material	Part number
1	Octagonal wrench for adapters	2.5" - 84 mm	1	PVC	I-WR05-AD



1

I-WR05-AD



WRENCHES

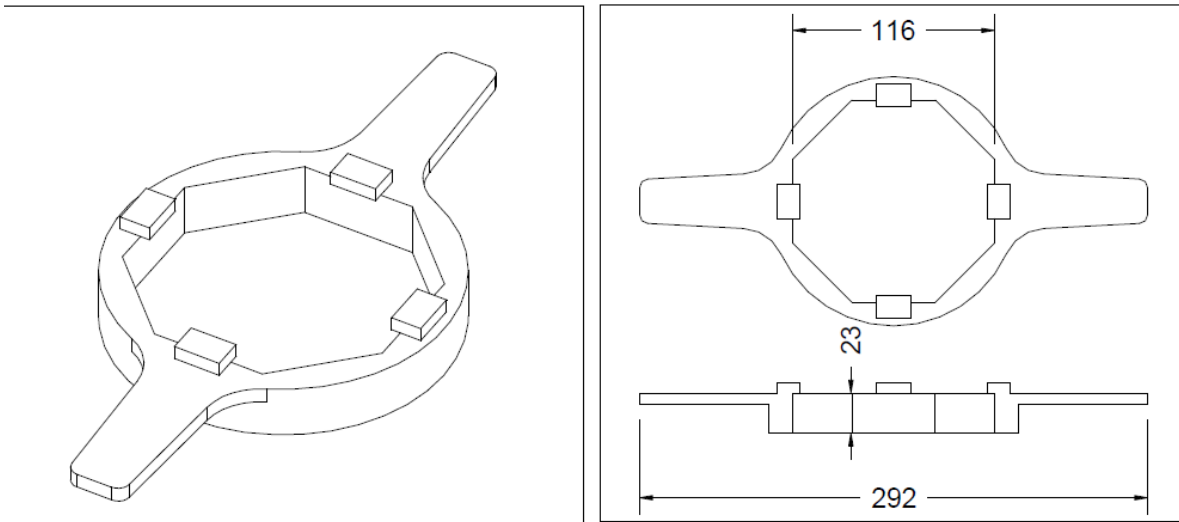
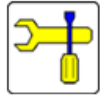

OCTAGONAL WRENCH FOR ADAPTERS
4" - 116 MM

Item	Description	Dimensions	Quantity	Material	Part number
1	Octagonal wrench for adapters	4" - 116 mm	1	PVC	I-WR06-AD
					I-WR06-AD

 1



WRENCHES

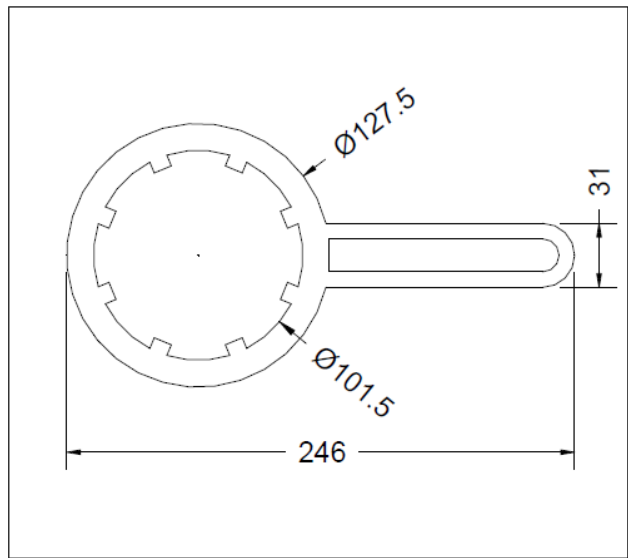
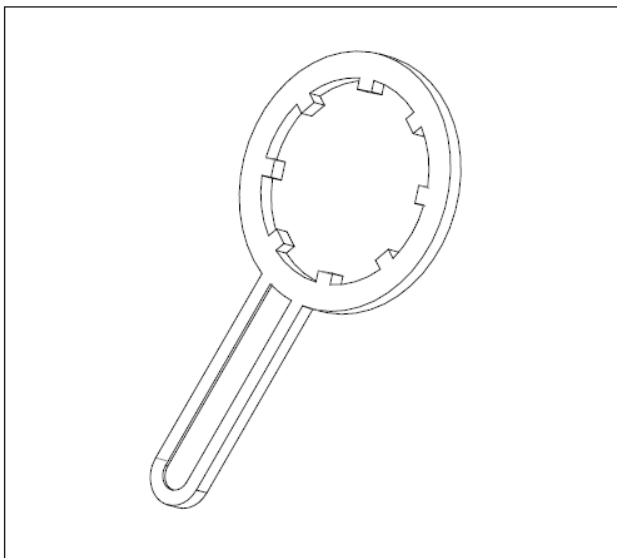

WRENCH FOR MANUAL VALVE



Item	Description	Dimensions	Quantity	Material	Part number
1	Wrench for manual valve	101.5	1	PP	A-ANA-S
					A-ANA-S



1



EXTENSION

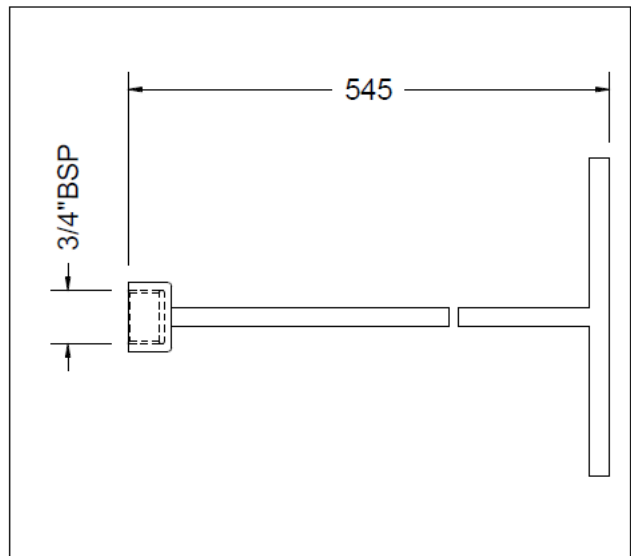
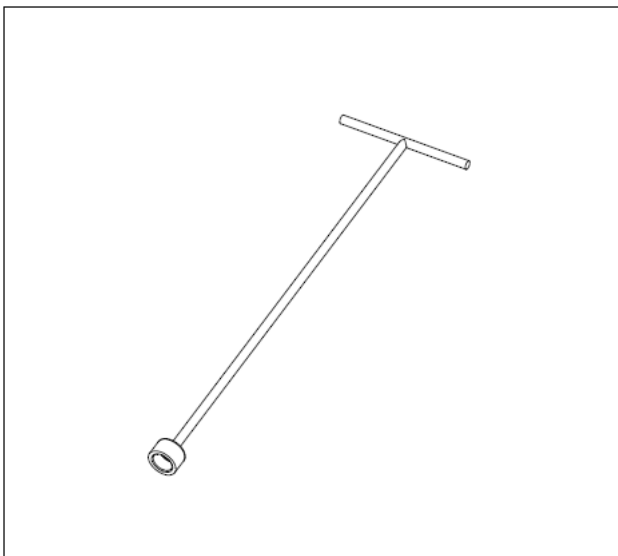
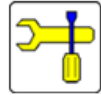

EXTENSION
3/4" BSP



Item	Description	Dimensions	Quantity	Material	Part number
1	Extension	3/4" BSP	1	STEEL	I-WR03-LA



1

I-WR03-LA



EXTENSION

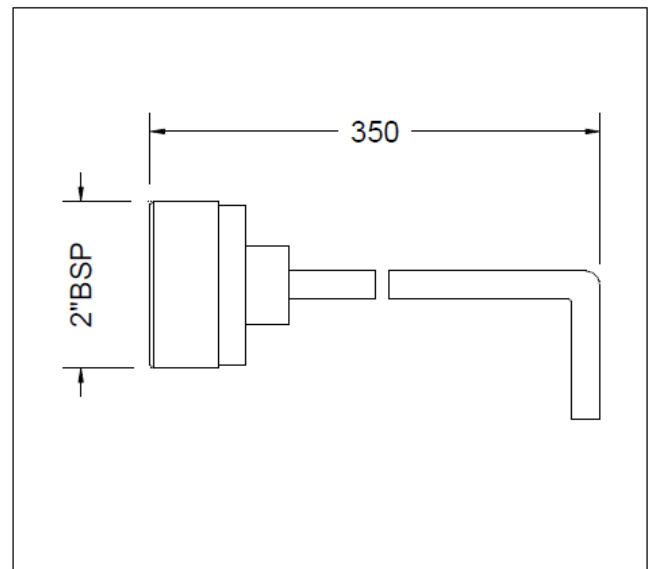
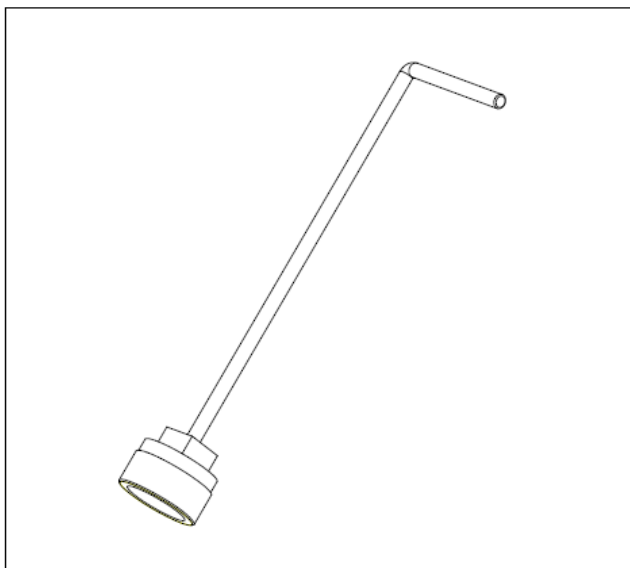
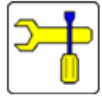

EXTENSION
2" BSP

Item	Description	Dimensions	Quantity	Material	Part number
1	Extension	2" BSP	1	STEEL	I-WR02-LA
					I-WR02-LA



1



EXTENSION

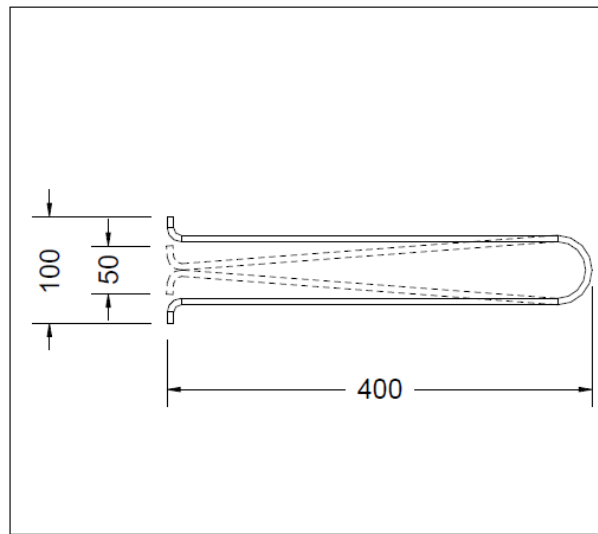
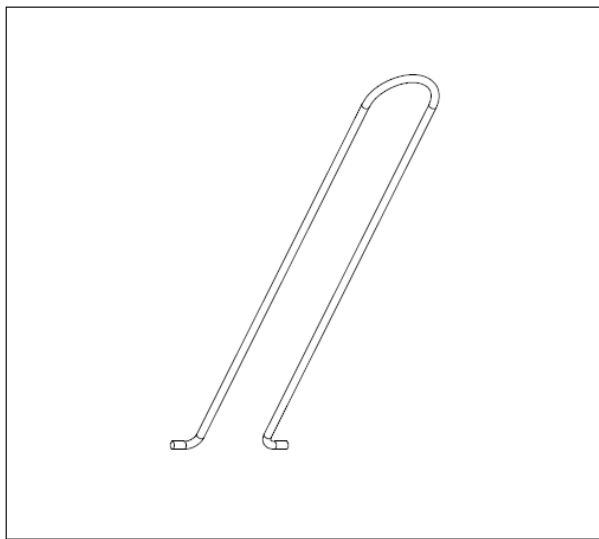
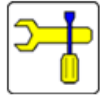

EXTENSION 6-8 HUBS

Item	Description	Dimensions	Quantity	Material	Part number
1	Extension	6-8-HUBS	1	STEEL	I-WR04-LA



1

I-WR04-LA



PENTAIR

SPARE PARTS



HUB

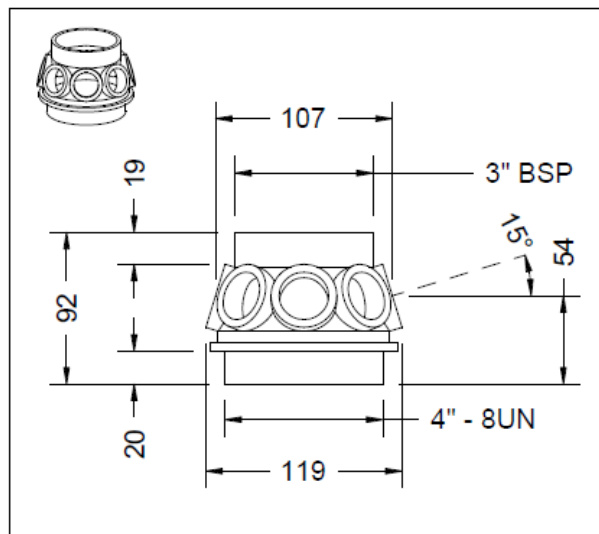
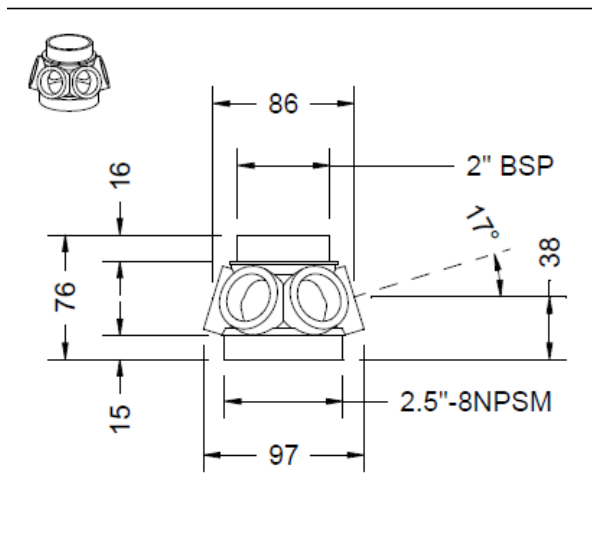
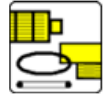

		Dimensions	Material	Part number
		Hub (6)	PP	AB-H60-00
		Hub (8)	PP	ATD-H60-00
		Hub (6)	PP-GF	ATD3-H60-00
		Hub (8)	PP-GF	ATD3-H80-00
		Hub (6)	PVDF	ATD1-H60-00
		Hub (8)	PVDF	ATD1-H80-00



HUBCAP

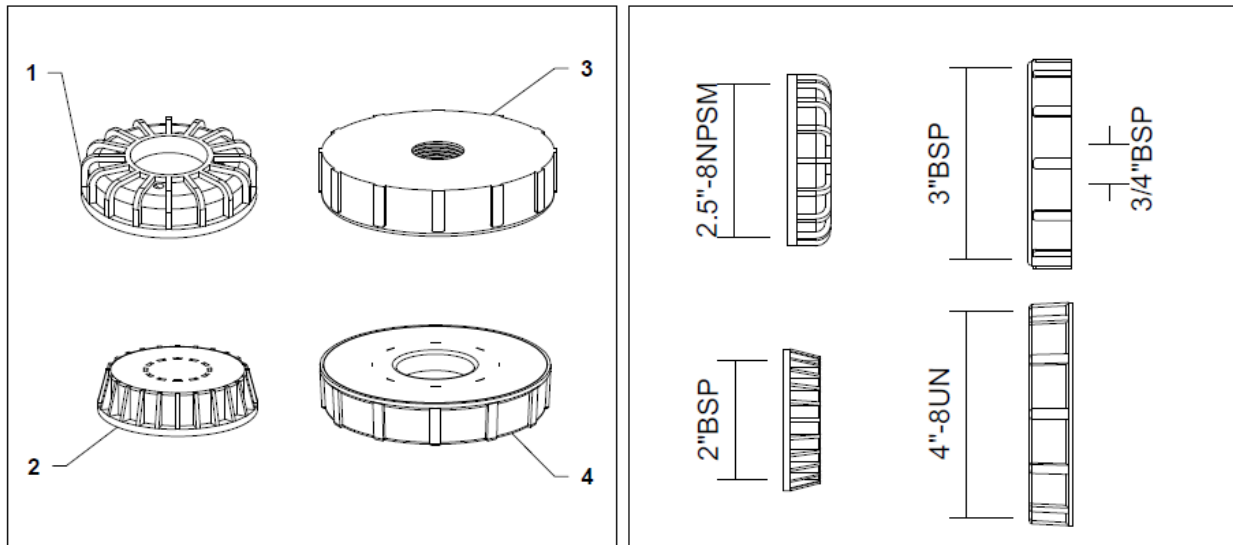





Item	Description	Part number		
		PP	PP-GF	PVDF
1	2.5" - 8 NPSM	AC-H60-00	AC3-H60-00	AC1-H60-00
2	2" BSP	AD-H60-00	AD3-H60-00	AD1-H60-00
3	3" BSP - 3/4" BSP	A-BTC8-30	A3-BTC8-30	A1-BTC8-30
4	4" - 8 UN	AD-H80-00	AD3-H80-00	AD1-H80-00

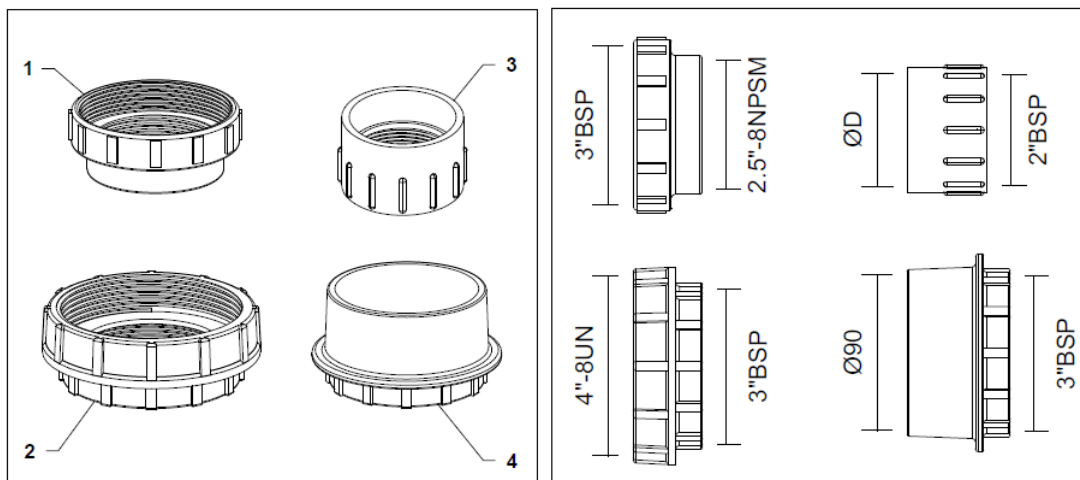

HUBADAPTER



Item	Description	 PVC PP (*)			 PP-GF			 PVDF 		
		Part number								
1	2.5" - 8 NPSM / 3" BSP	AB-C08-30*	AB3-C08-30	AB1-C08-30						
2	3" BSP / 4" -8 UN	AB-C08-40*	AB3-C08-40	AB1-C08-40						
3	2" BSP / D = 50mm	A-2600-63	-	-						
3	2" BSP / D = 60mm	A-1075-1	-	-						
3	2" BSP / D = 63mm	A-1074-1	-	-						
4	3" BSP / 90mm	AB-GC8-30	-	-						



LATERAL

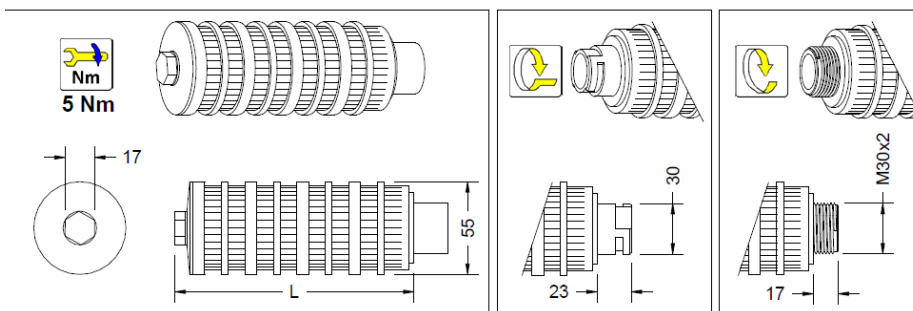

			PVDF	White
			PP-GF PPO	Black
			PP	Gray
			PP	Yellow

L (mm) Length							
113	A-BT02-113	A-BT05-113	A-TH02-113	A-TH05-113	A3-TH02-113	A1-TH02-113	6
175	A-BT02-175	A-BT05-175	A-TH02-175	A-TH05-175	A3-TH02-175	A1-TH02-175	6
268	A-BT02-268	A-BT05-268	A-TH02-268	A-TH05-268	A3-TH02-268	A1-TH02-268	6
330	A-BT02-330	A-BT05-330	A-TH02-330	A-TH05-330	A3-TH02-330	A1-TH02-330	6
361	-	-	A-TH02-361	A-TH05-361	A3-TH02-361	A1-TH02-361	8
423	-	-	A-TH02-423	A-TH05-423	A3-TH02-423	A1-TH02-423	8
485	-	-	A-TH02-485	A-TH05-485	A3-TH02-485	A1-TH02-485	8
515	-	-	A-TH02-515	A-TH05-515	A3-TH02-515	A1-TH02-515	8
578	-	-	A-TH02-578	A-TH05-578	A3-TH02-578	A1-TH02-578	8



DIFFUSOR



Nm
5 Nm

			PVDF	White
			PP	Gray
			PP	Yellow

T2 (mm) Thread	T1(mm) Thread	h (mm) Height	L (mm) Length	65°C		99°C	
2" BSP	ø50	30	126	A-2721-26	-	-	1
2" BSP	ø50	30	180	A-2721-80	A-2600-65	A1-2742-BSP	1
2.5" - 8 NPSM	2" BSP	20	180	A-2740--	A-2746--	A1-2740--	1
2.5" - 8 NPSM	2" BSP	20	338	-	A-2746-338	-	1



UNION

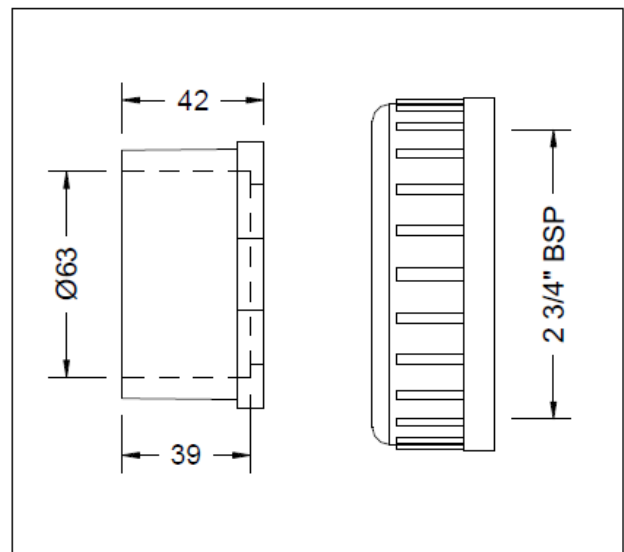
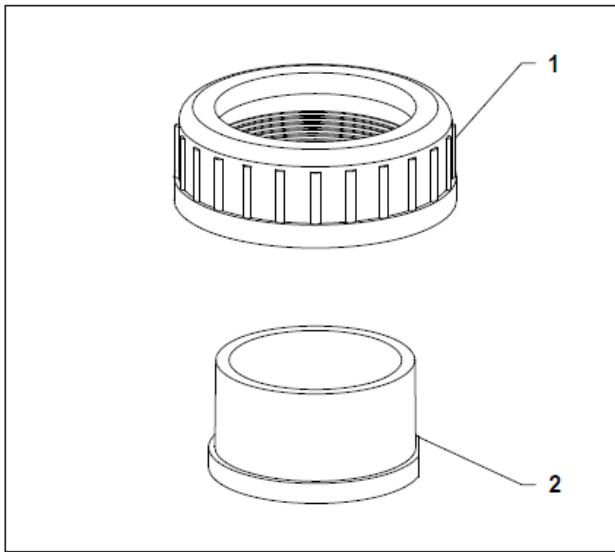

Item	Description	Material	Part number
1	Collat	PVC	A-8250-63
2	Union nut	PVC	A-8200-63



5

A-8200-63C



ELBOW

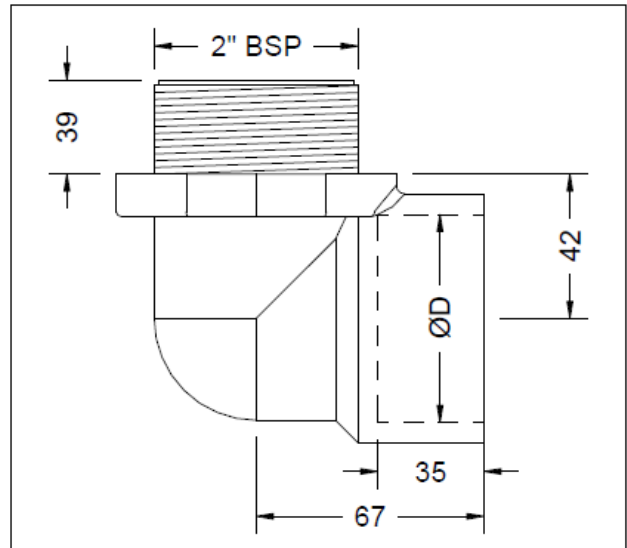
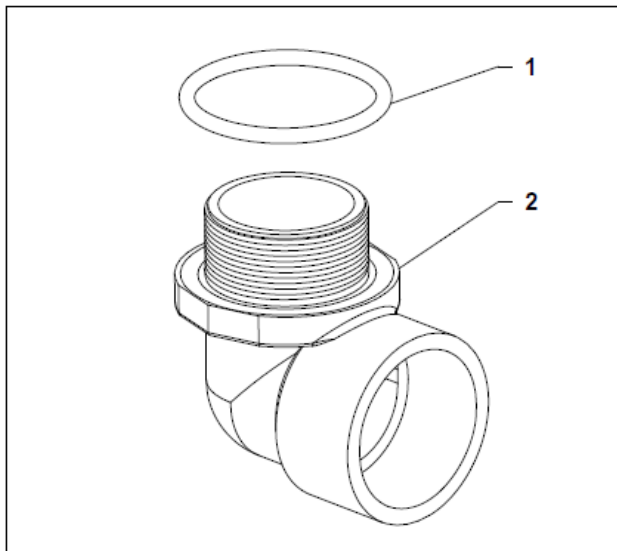

Item	Description	Material	D= 60 mm	D= 63 mm
			Part number	
1	O-ring	NBR	A-2694-17	A-2694-17
2	Elbow	PVC	A-2700--	A-2693--
			A-2700-C	A-2693-C





5

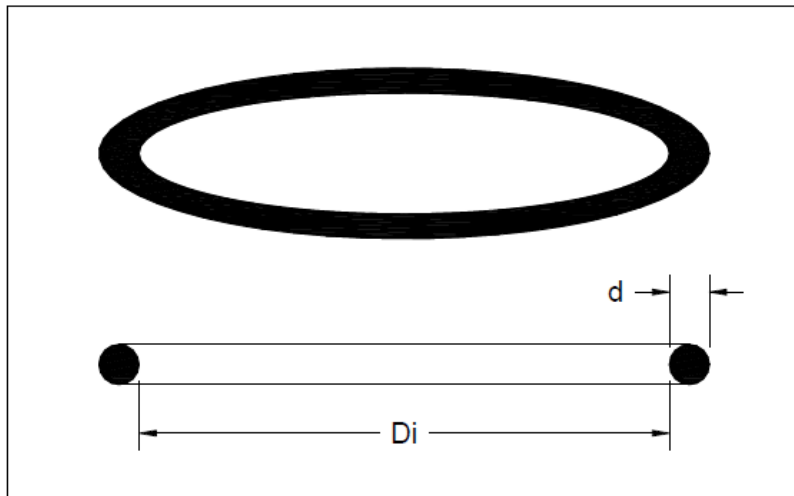

O'RING



Di	d	AS-N°			 		
			NBR	EPDM	FPM	FEP	
56.52	5.33	AS331	A-2694-60	-	-	-	20
66.04	5.33	AS334	A-2694-17	-	-	-	20
68	3.53	-	-	A-2694-1	-	-	20
98	4	-	A-2694-3	-	-	-	20
110	4	-	A-2694-3F	-	-	-	20
115	5	-	A-2694-BF	-	-	-	20
145.64	3.53	AS256	A-2694-19	-	-	-	20
183.52	6.99	AS442	A-2694-8F	-	A-2694-V8F	A-2694-F8F	20



FLAT SEAL

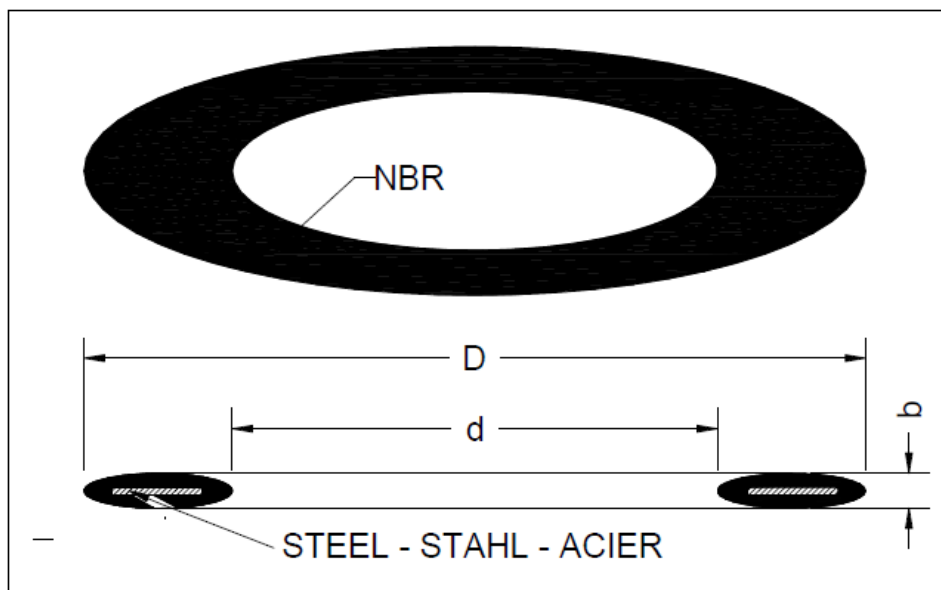

DN DIN2690	D	d	b	Part Number	
DN50	107	61	4	A-2600-68	10
DN65	127	77	4	-	10
DN80	142	90	4	A-2600-71	10
DN100	162	115	5	A-2600-67	10
DN125	192	141	5	-	5
DN150	218	169	5	A-DN15-0D	5
DN200	273	220	6	A-DN20-0D	5
DN300	378	325	6	A-DN30-0D	5
DN400	490	420	7	A-DN40-0D	5



Contact us:

By mail

Commercial support

commercial.prfemea@pentair.com

Technical support

techsupport.water@pentair.com

Marketing support

marketing.prfemea@pentair.com

By phone

Tel. +41 21 623 69 69