

INSTALLATION INSTRUCTIONS

Horizontal Vent Terminal Location

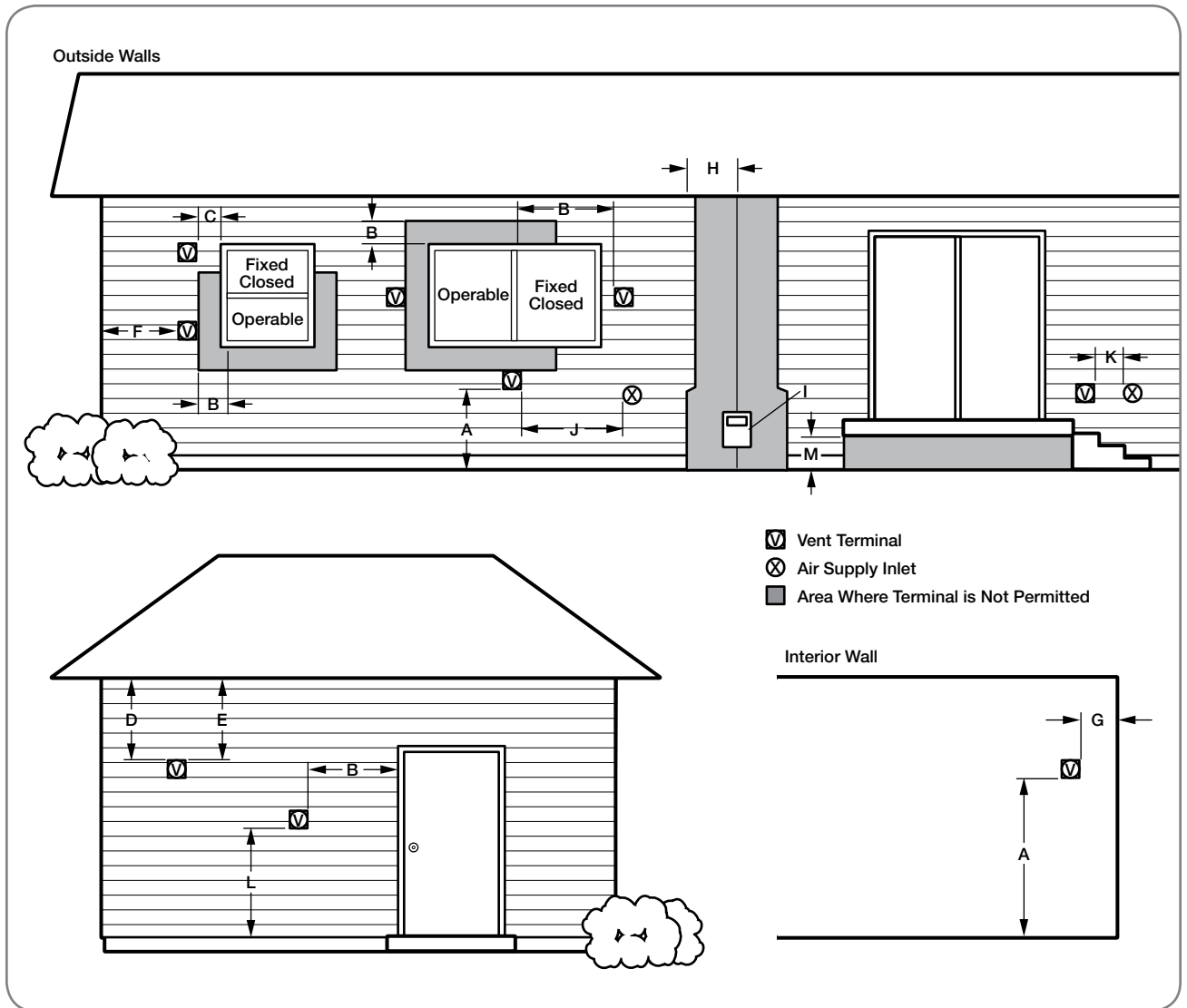

Venting

INSTALLATION INSTRUCTIONS



Venting for Direct-Vent Water Heater (cont.)

The following chart details the minimal dimensional information needed to determine the proper location of the vent terminal for direct vent and outdoor tankless water heaters. See corresponding letter reference in the illustration at left.

Location	U.S. Installation Requirements ¹	Canadian Installation Requirements ²
A = Clearance above grade, veranda, porch, deck, or balcony.	12 in. (30 cm) above anticipated snow level.	12 in. (30 cm) above anticipated snow level.
B = Clearance to window or door that may be opened.	<ul style="list-style-type: none"> • 6 in. (15 cm) for water heaters less than or equal to 10,000 Btuh (3 kW). • 9 in. (23 cm) for water heaters greater than 10,000 Btuh (3 kW) and less than or equal to 50,000 Btuh (15 kW). • 12 in. (30 cm) for water heaters greater than 50,000 Btuh (15 kW). 	<ul style="list-style-type: none"> • 6 in. (15 cm) for water heaters less than or equal to 10,000 Btuh (3 kW). • 12 in. (30 cm) for water heaters greater than 10,000 Btuh (3 kW) and less than or equal to 100,000 Btuh (30 kW). • 36 in. (91 cm) for water heaters greater than 100,000 Btuh (30 kW).
C = Clearance to permanently closed window.	★	★
D = Vertical clearance to ventilated soffit located above the terminal within a horizontal distance of 2 ft. (61 cm) from the centerline of the terminal.	★	★
E = Clearance to unventilated soffit.	★	★
F = Clearance to outside corner.	★	★
G = Clearance to corner.	★	★
H = Clearance to each side of centerline extended above meter/regulator assembly.	★	3 ft. (91 cm) within a height of 15 ft. (4,57 m) above the meter/regulator assembly.
I = Clearance to service regulator vent outlet.	★	3 ft. (91 cm)
J = Clearance to nonmechanical air supply inlet to the combustion air inlet to any building or other appliance.	<ul style="list-style-type: none"> • 6 in. (15 cm) for water heaters less than or equal to 10,000 Btuh (3 kW). • 9 in. (23 cm) for water heaters greater than 10,000 Btuh (3 kW) and less than or equal to 50,000 Btuh (15 kW). • 12 in. (30 cm) for water heaters greater than 50,000 Btuh (15 kW). 	<ul style="list-style-type: none"> • 6 in. (15 cm) for water heaters less than or equal to 10,000 Btuh (3 kW). • 12 in. (30 cm) for water heaters greater than 10,000 Btuh (3 kW) and less than or equal to 100,000 Btuh (30 kW). • 36 in. (91 cm) for water heaters greater than 100,000 Btuh (30 kW).
K = Clearance to mechanical air supply inlet.	3 ft. (91 cm) above if within 10 ft. (3 m) horizontally.	6 ft. (1,83 m)
L = Clearance above paved sidewalk or paved driveway located on public property.	★	7 ft. (2,13 m) [†]
M = Clearance under veranda, porch, deck, or balcony.	Not Allowed	Not Allowed

¹ In accordance with current ANSI Z223.1/NFPA 54 National Fuel Gas Code.

² In accordance with current CSA B149.1 Installation Codes.

★ For clearances not specified in ANSI 223.1/NFPA 54 or CSA B149.1, one of the following shall be indicated:

- A minimum clearance value determined by testing in accordance with section 2.20, or
- A reference to the following footnote: "Clearance in accordance with local installation codes and the requirements of the gas supplier."

[†] A vent shall not terminate directly above a sidewalk or paved driveway that is located between two single-family dwellings and serves both dwellings.

INSTALLATION INSTRUCTIONS

Horizontal Vent Considerations

⚠WARNING: Moisture in the flue gas will condense as it leaves the vent terminal. In cold weather this condensate can freeze on the exterior wall, under the eaves, and on surrounding objects. Some discoloration to the exterior of the building is to be expected. However, improper location or installation can result in severe damage to the structure or exterior finish of the building.

- **Do not** install vent terminals under any patio or deck.
- **Do not** locate vent terminal on the side of a building with prevailing winter winds. This will help prevent water lines from freezing and moisture from freezing on walls and under eaves.
- **Do not** locate vent terminal too close to shrubbery, since flue gases may damage them.
- All painted surfaces should be primed to lessen the chance of physical damage. Painted surfaces will require maintenance.
- Guard against accidental contact with people and pets.

INDOOR TANKLESS WATER HEATERS

⚠WARNING: For multiple-unit installation, a minimum distance between vent terminations must be maintained to prevent recirculation of vent gases. Maintain a center-to-center distance between each pair of vent terminations of 24 in. (61 cm) for a two-unit installation; 24 in. (61 cm) and 36 in. (91.4 cm) for an installation of three units; and 24 in. (61 cm), 36 in. (91.4 cm), and 24 in. (61 cm) for an installation of four units.

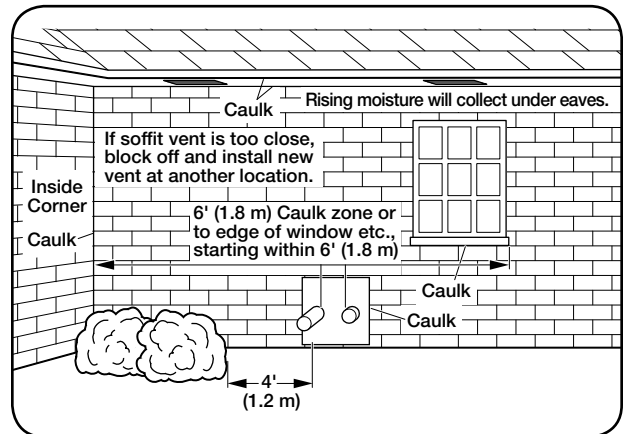

- **Do not** terminate vent directly on brick or masonry surfaces. Use rust-resistant, sheet-metal backing plate of 1 sq. ft. (30 sq. cm) behind the vent.
- Caulk all cracks, seams, and joints within 6 ft. (1.8 m) of the vent terminal.
- Caulk around wall faceplate for weather-tight seal.
- **Do not** extend exposed vent pipe of indoor water heaters outside of the building.
- This water heater requires its own separate venting system. **Do not** connect the exhaust vent to an existing vent pipe or chimney.

OUTDOOR TANKLESS WATER HEATERS

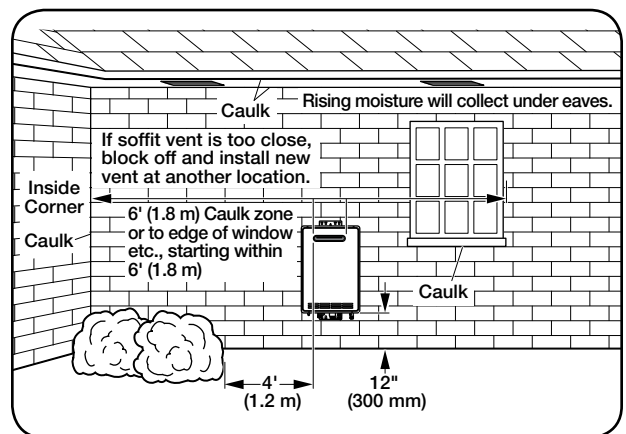

- Install outdoor water heater such that air inlet and flue outlet are above anticipated snow level.

INSTALLATION INSTRUCTIONS



Venting for Direct-Vent Water Heater (cont.)

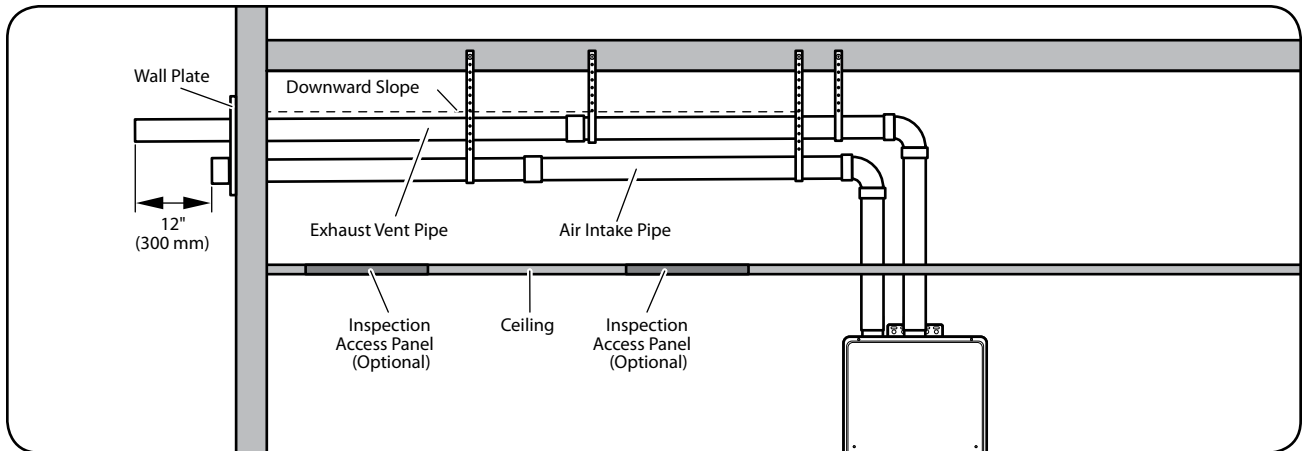

Horizontal Vent Installation

⚠WARNING: Danger of fire or bodily injury – Solvent cements and primers are highly flammable. Provide adequate ventilation and do not assemble near heat source or open flame. Do not smoke. Avoid skin or eye contact. Observe all cautions and warnings on material containers.

⚠CAUTION: Use tankless water heater manufacturer-approved Schedule 40 PVC (foam core is not permitted at any time), Schedule 80 PVC, CPVC, ABS polypropylene, or UL 1738-listed Category III Stainless Steel. No other vent material is permitted.

Joining Pipes and Fittings

All pipe, fittings, solvent cement, primers, and procedures, for the U.S., must conform to American National Standards Institute and American Society for Testing and Materials (ANSI/ASTM) standards. For Canada, all pipe, fittings, solvent cement, primers, and procedures must conform to ULC-S636 and vent manufacture specifications.

⚠CAUTIONS:

- Do NOT use solvent cement that has become curdled, lumpy, or thickened.
- Do NOT thin solvent cement. Observe shelf precautions printed on the containers.
- For applications below 32°F, use only lower temperature-type solvent cement.
- Appropriate solvent and cleaner must be used for the type of vent pipe used (PVC, CPVC, or ABS).

Cleaner-Primer and Medium-Body Solvent Cement

All joints in vent piping must be properly sealed, and we recommend using the following material: PVC materials should use ASTM D-2564-grade cement.

CPVC materials should use ASTM F-493-grade cement.

ABS materials should use ASTM D-2235-grade cement (ABS is not allowed in Canada).

Cementing Joints

1. Cut pipe end square; remove jagged edges and burrs. Chamfer end of pipe; then clean fitting socket and pipe joint area of all dirt, grease, or moisture.
2. After checking pipe and socket for proper fit, wipe socket and pipe with cleaner-primer. Apply a liberal coat of primer to inside surface of socket and outside of pipe.
3. Apply a thin coat of cement evenly in the socket. Quickly apply a heavy coat of cement to the pipe and insert pipe into fitting with a slight twisting motion until it bottoms out.
4. Hold the pipe fitting for 30 seconds to prevent the tapered socket from pushing the pipe out of the fitting.
5. Wipe all excess cement from the joint with a rag. Allow 15 minutes before handling. Cure time will vary according to fit, temperature, and humidity.

NOTICES:

- Cement must be fluid; if not, recoat.
- Stir the solvent frequently while using. Use a natural bristle brush or the dauber supplied with the can. The proper brush size is one inch.

INSTALLATION INSTRUCTIONS

Horizontal Vent Installation (cont.)

Fasteners will vary depending on the wall type.

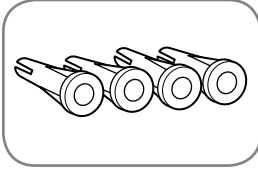

For particle board or composite sheathing, use 4 hollow wall anchors. The anchors should be at least 1/8 in. (0.3 cm) in diameter and the appropriate length for the sheathing thickness.

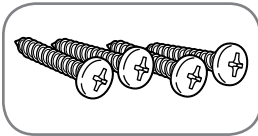

For plywood or solid wood sheathing or members, use 4 #10 x 1 1/4-in. wood screws.

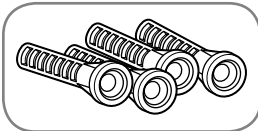

For masonry walls, use suitable masonry anchors long enough to pass through the wall.

NOTICES:

- The distance between the back edge of the **exhaust vent** terminal and the exterior wall must be 12 inches (30.5 cm) more for the exhaust vent terminal than the **air intake** terminal.
- To prevent possibility of condensate freeze-up, do not install vent kits one above the other.

Once the vent terminal location has been determined, make holes through the exterior wall to accommodate the vent pipes. Vent pipes must exit exterior wall horizontally only.

The standard horizontal air intake termination is a 2-inch or 3-inch pipe which terminates at the exterior wall and uses a coupling to prevent the pipe from being pushed back into the structure. The standard horizontal exhaust outlet termination is a 2-inch or 3-inch pipe which terminates 12 inches from the air intake termination. Insert a small length of vent pipe through the wall and connect the coupling. Connect vent cap or terminal to the vent pipe on the exterior of the building.

1. Use the vent plate as a template to locate air intake holes and four mounting holes. Observe minimum clearances. Vent terminals must be a minimum of 5.5 inches (14 cm) and a maximum of 24 inches (61 cm) apart horizontally.
2. Cut two 2 1/2" (6.4 cm) diameter holes (for a 2" [5.1-cm] diameter pipe) or 3 1/2" (8.9 cm) diameter holes (for a 3" [7.6-cm] diameter pipe) for the exhaust vent and air intake openings.

Reinstall the decorative sheathing around the faceplate. The decorative sheathing may be painted to match the exterior decor.

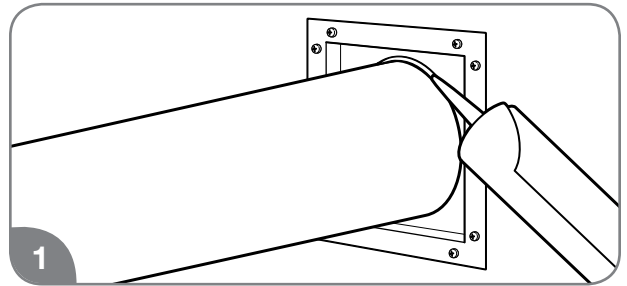

1 Apply silicone sealant or silicone/latex caulk to seal the vent pipe to the vent cap to permit field disassembly for annual inspection and cleaning. Completely seal where it passes through the wall plate and where it is attached to the structure.

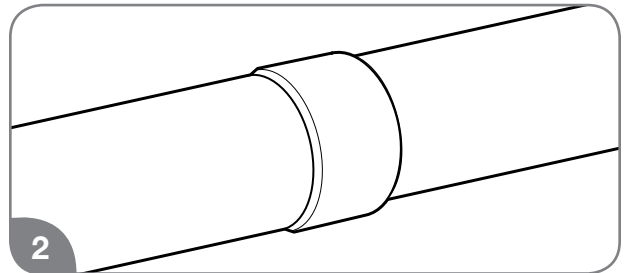

2 Attach the female end of the next vent pipe section to the male end of the 2-in./3-in. (5.1-cm/7.6-cm) vent pipe. See "Cementing Joints" on page 40.

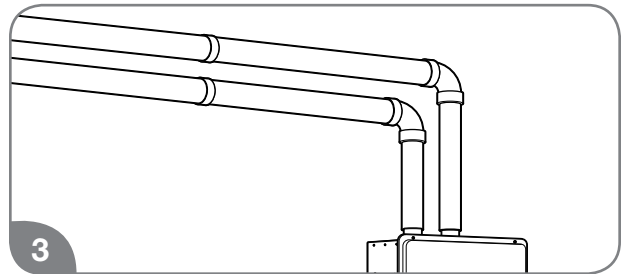

3 Complete the rest of the vent pipe installation to the water heater's flue outlet and air intake.

INSTALLATION INSTRUCTIONS

For information about termination kits, refer to "If You Need Service" on page 26, "Call for Assistance" for the telephone number to speak to Customer Service Representative.



Venting for Direct-Vent Water Heater (cont.)

Alternative Horizontal Vent Installations

Alternative horizontal vent termination kits are commercially available. Please refer to the instruction sheet packaged with the kit for complete installation instructions.

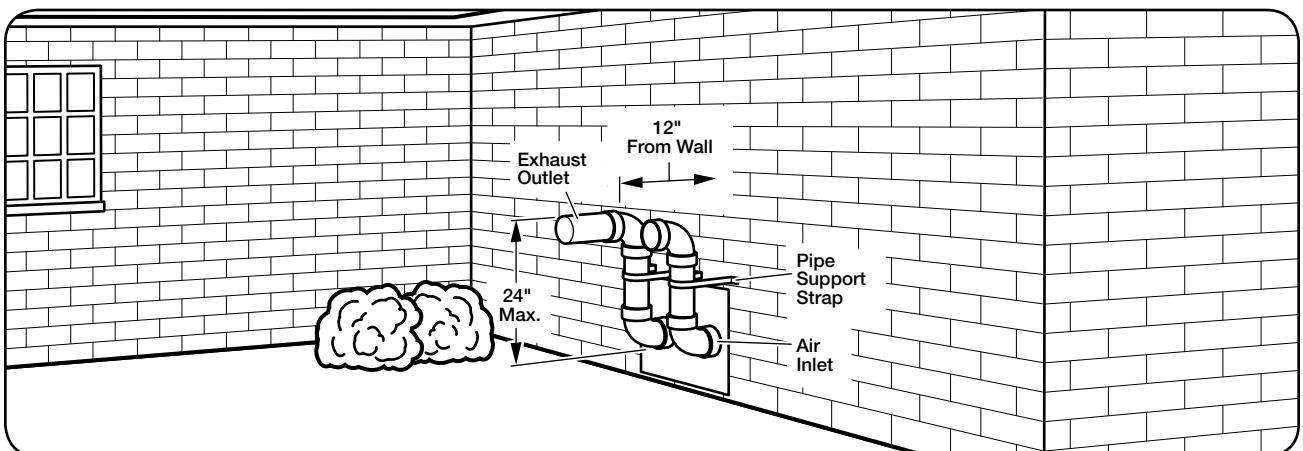
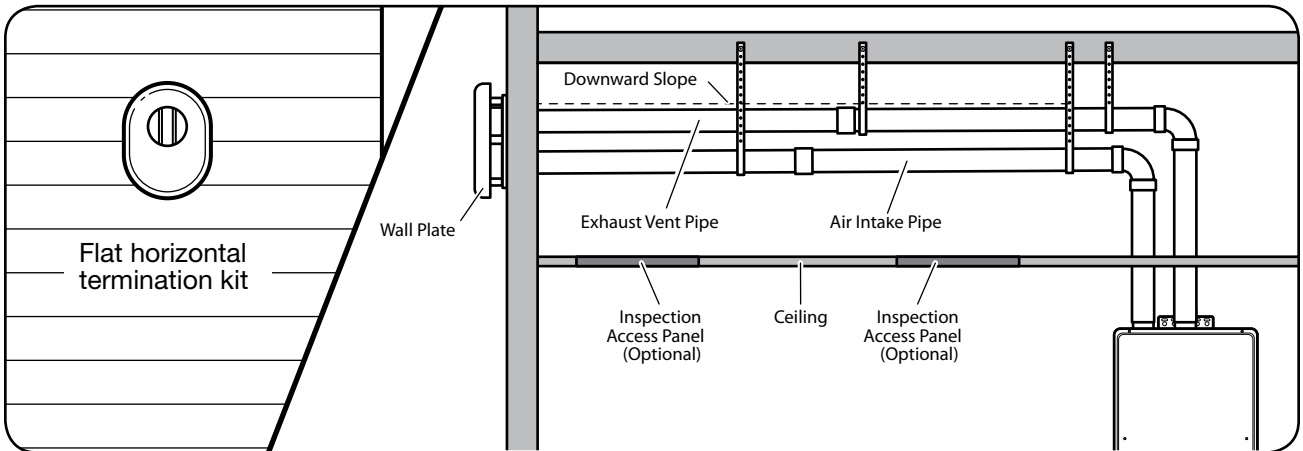
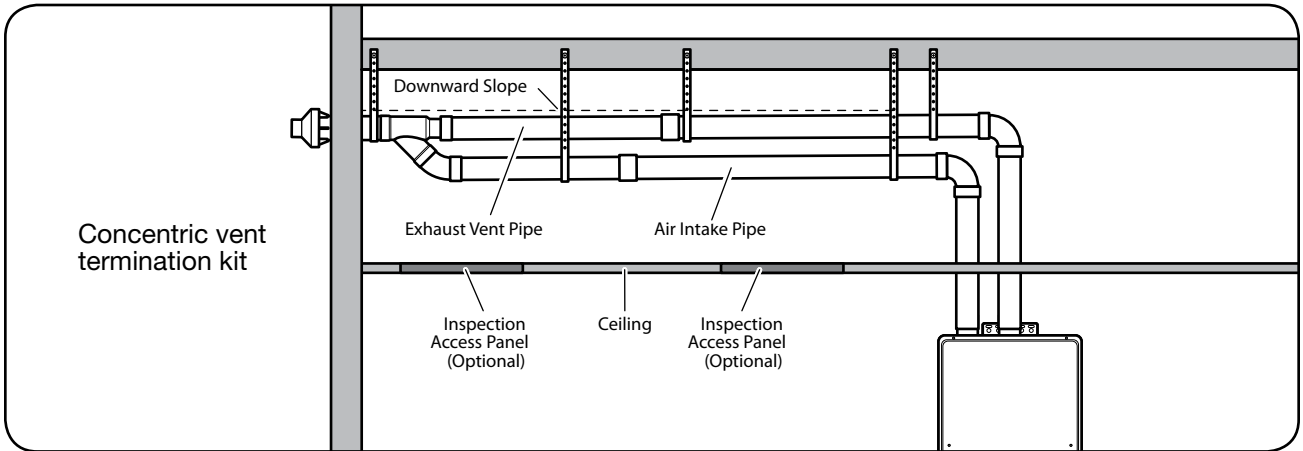

Venting

INSTALLATION INSTRUCTIONS

Vertical Vent Installation

⚠ WARNING: Improper vent installation can result in death, personal injury, product damage, and/or poor performance.

NOTICES:

- Only Rheem-approved termination and parts should be used during installation.
- Maintain the recommended air space clearance to combustible materials and building insulation.

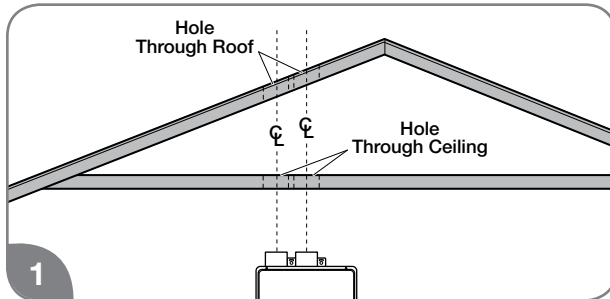

Cut a hole through the roof and interior ceiling to accommodate the vent pipes.

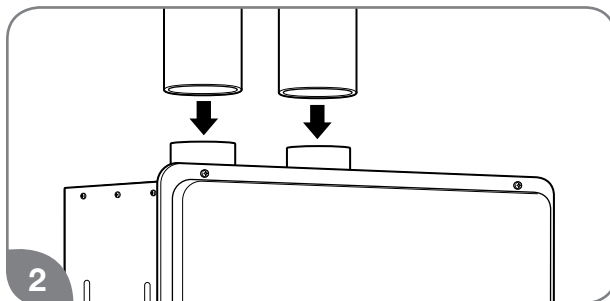

Complete the vent pipe installation to the water heater's vent connector fittings. Use cleaner-primer and PVC cement where the vent pipes join the water heater.

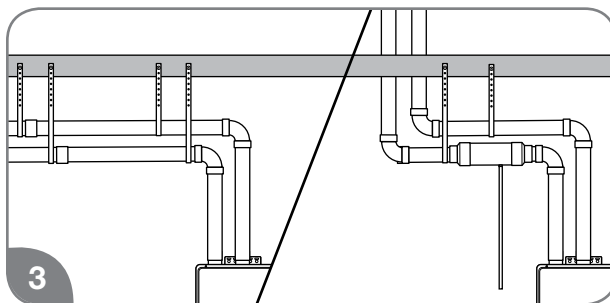

Support vertical and horizontal runs as described on page 35. Vertical supports are required every 4 ft. (1.2 m) along a vertical pipe route, after every transition to vertical, and after every offset elbow.

NOTICE: Free-standing vent pipe that penetrates a roof/ceiling requires another means of support from a second location.

Determine the vent terminal height and install the vent pipe accordingly. Refer to "Vertical Vent Terminal Location" on page 44 for clearance requirements.

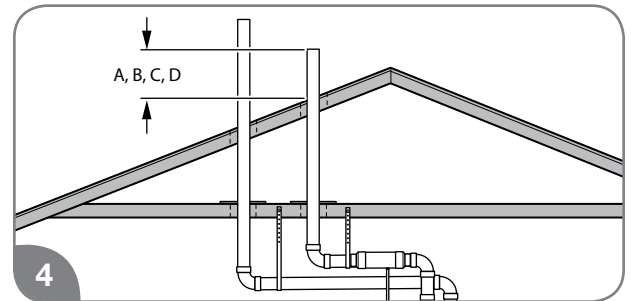

Install adequate flashing where the vent pipe passes through the roof.

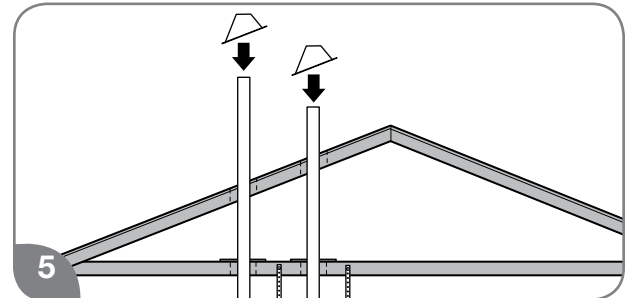

Air Intake Condensate Trap

For vertical terminations or where the air intake pipe slopes down towards the water heater, it is recommended to install a drain tee assembly. This is to prevent any condensate or liquid water from entering the intake of the water heater. Connect the trap drain line to a suitable drain. Do not connect it directly to the condensate drain line from the water heater.

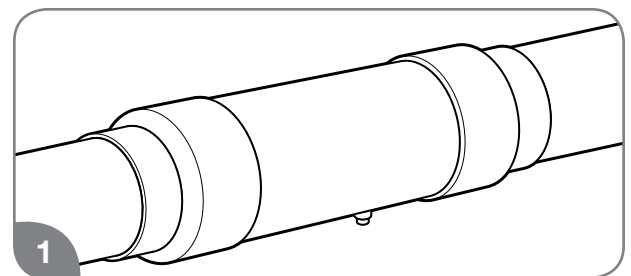

One trap method: Glue a 3" by 4" adapter coupling to each end of a 4" PVC pipe length. Drill a 1/2" hole in the side of the larger diameter pipe. Tap and thread for a 1/2" barbed fitting, install fitting. Install the collector with the fitting facing down. Connect a drain hose to the fitting and clamp, run hose to a suitable drain.

INSTALLATION INSTRUCTIONS



Venting for Direct-Vent Water Heater (cont.)

Vertical Vent Terminal Location

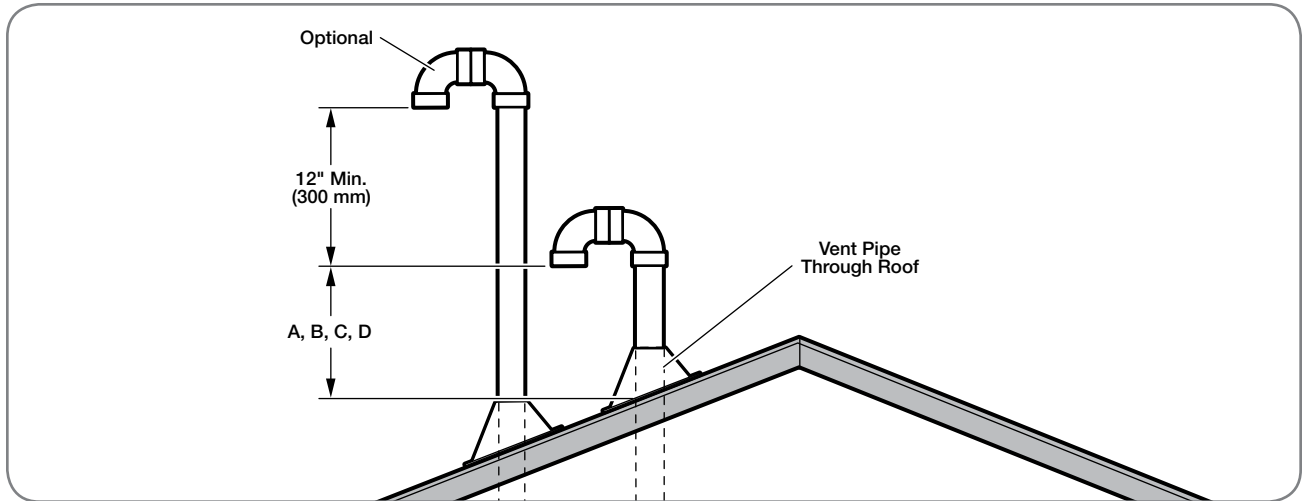

The following chart with diagrams details the minimum dimensional information needed to determine the proper location of the vertical vent terminal for direct-vent indoor tankless water heaters:

Location	U.S. Installation Requirements ¹	Canadian Installation Requirements ²
A = Minimum clearance above the roof level.	12 in. (30.5 cm) above roof level.	18 in. (45.7 cm) above roof level.
B = Minimum clearance above anticipated snow level.	12 in. (30.5 cm) above anticipated snow level.	12 in. (30.5 cm) above anticipated snow level.
C = Maximum clearance above roof level (without additional support for vent pipe).	24 in. (61 cm) above roof level.	24 in. (61 cm) above roof level.
D = Maximum clearance above anticipated snow level (requires additional vent support).	24 in. (61 cm) above anticipated snow level.	24 in. (61 cm) above anticipated snow level.
E = Required vent clearance from any gable, dormer, or other roof structure with building interior access (i.e., vent, window).	4 ft. (1.2 m)	4 ft. (1.2 m)
F = Required vent clearance from any forced air inlet, including dryer and furnace air inlets.	10 ft. (3 m)	6 ft. (1.8 m)
G = Minimum/maximum horizontal distance between vent terminals	5.5 in. (14 cm)/24 in. (61 cm)	5.5 in. (14 cm)/24 in. (61 cm)

¹ In accordance with current ANSI Z223.1/NFPA 54 National Fuel Gas Code.

² In accordance with current CSA B149.1 Installation Codes.

The vertical intake air termination requires a return bend or two short or long sweep radius 90° elbows to keep the inlet downward and prevent entry of rain. Refer to figure above for the proper location of the air intake with respect to the exhaust outlet termination. The vertical exhaust outlet termination is a 2-inch or 3-inch pipe which terminates at least 12 inches above the air intake termination. The air intake and exhaust outlet terminations must be at least 12 inches above the roof line or anticipated snow levels.

INSTALLATION INSTRUCTIONS

Standard Vertical Vent Termination

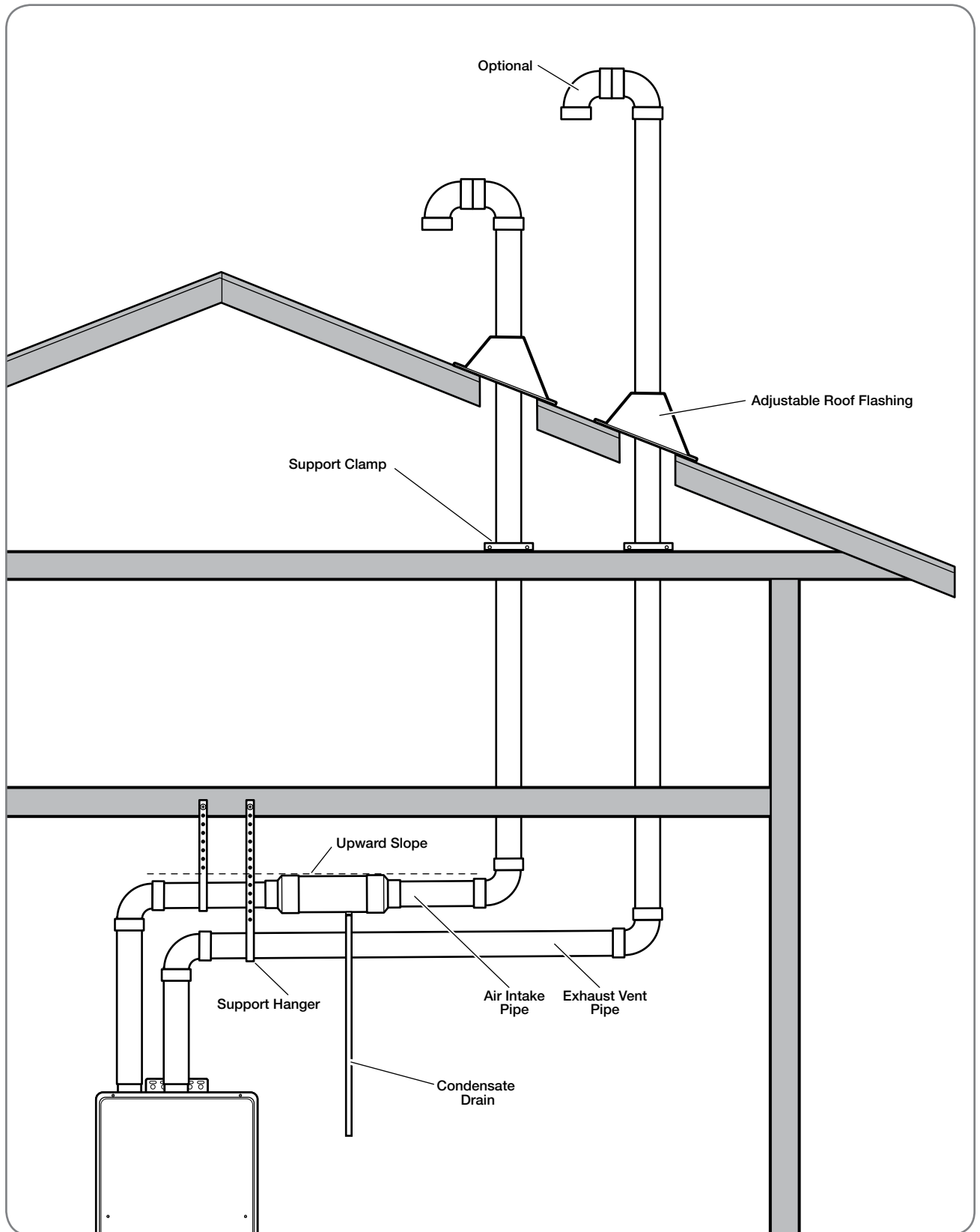

Venting

INSTALLATION INSTRUCTIONS



Venting for Direct-Vent Water Heater (cont.)

Alternative Vertical Vent Termination

Alternative vertical vent termination kits are commercially available. Please refer to the instruction sheet packaged with the kit for complete installation instructions.

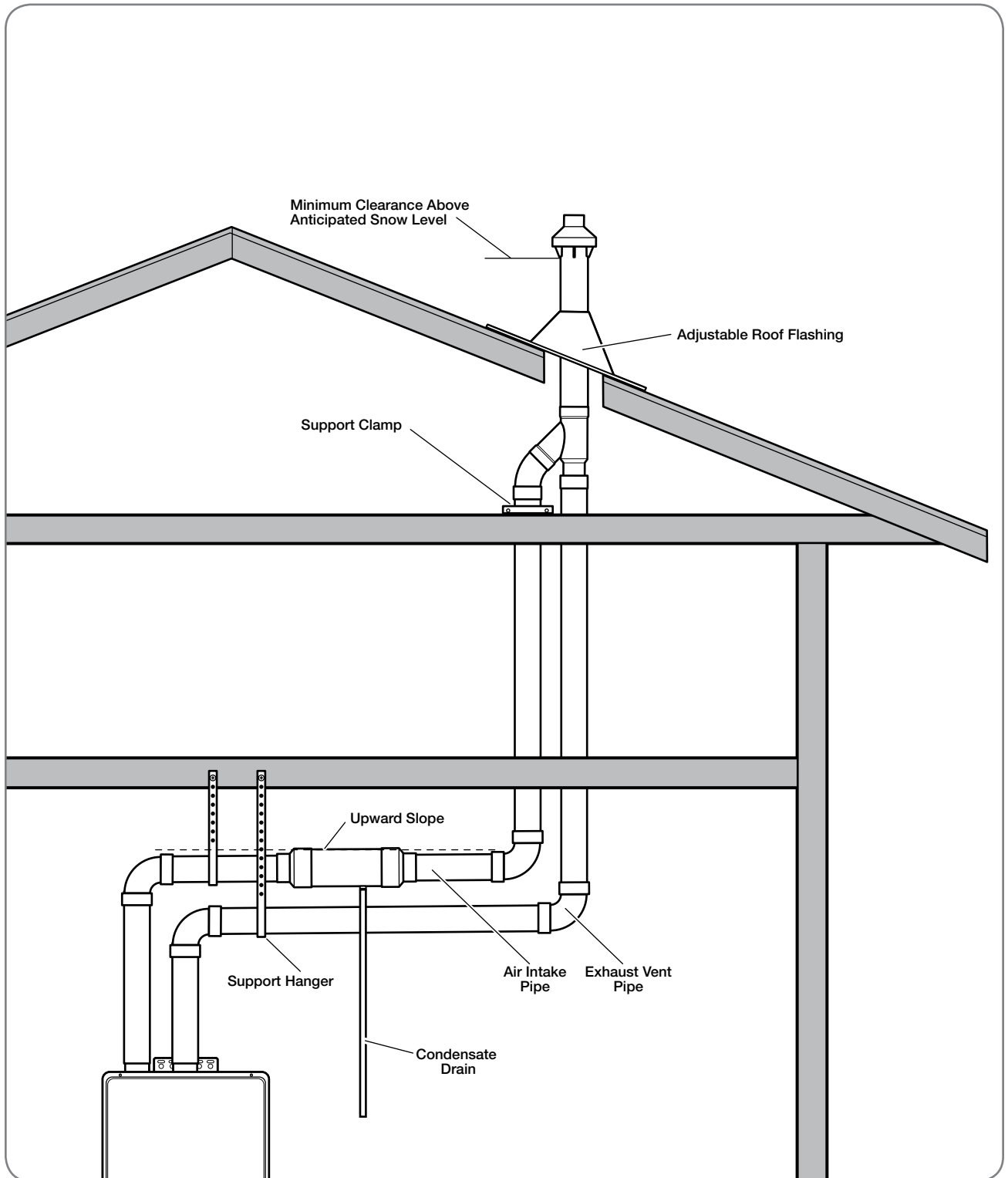



Water Supply

⚠ CAUTION: This water heater MUST ONLY be used with the following water supply conditions to prevent product damage and operation failure.

- Clean, potable water free of corrosive chemicals, sand, dirt, or other contaminants.
- Inlet water temperatures above 32°F (0°C), but not exceeding 120°F (49°C).
- DO NOT reverse the HOT and COLD water connections.
- DO NOT connect this water heater to water lines previously used for space heating. All water piping and components shall be suitable for potable water.
- With recommended water quality (see chart).

Thermal Expansion

A thermal expansion tank will be required if the water heater is installed in a recirculation system. This prevents damage to the heater, related piping, and the relief valve.

NOTICE: Replacing the relief valve will not correct the problem!

The expansion tank is designed with a built-in air cushion that compresses as the system pressure increases. This relieves the over-pressure condition and eliminates the repeat operation of the relief valve.

For other approved methods of thermal expansion, contact an installing contractor, water supplier, or plumbing inspector.

Chart for Recommended Water Quality Levels

pH	TDS (Total Dissolved Solids)	Free Carbon Dioxide (CO ₂)	Total Hardness	Aluminum	Chlorides	Copper	Iron	Manganese	Zinc
6.5–8.5	Up to 500 mg/L	Up to 15 mg/L	Up to 200 mg/L	Up to 0.2 mg/L	Up to 200 mg/L	Up to 1.0 mg/L	Up to 0.3 mg/L	Up to 0.05 mg/L	Up to 1.0 mg/L

Water Supply Connections

⚠ CAUTION: IMPORTANT—Do not apply heat to the HOT or COLD water connections. If sweat connections are used, sweat tubing to the adapter before fitting the adapter to the water connections on the water heater. Any heat applied to the water supply fittings will permanently damage the internal components of the water heater.

NOTICE: In cold environments, ice can accumulate in the water heater's connectors. Plug in the water heater power cord for approximately 10 minutes before making these connections. This will melt any ice buildup.

Plumbing should be carried out by a qualified plumbing contractor in accordance with local codes.

Only use approved plumbing materials.

The minimum diameter of all water pipes should be 3/4 in. (1.9 cm).

To conserve energy and to prevent freezing, insulate both COLD and HOT water supply lines.

Do not insulate the drain line or pressure-relief valve.

INSTALLATION INSTRUCTIONS



Water Supply

Water Supply Connections (cont.)

To ensure proper operation of the water heater, follow these water pressure guidelines.

- Operation of the water heater requires a minimum water pressure of 14 psi (97 kPa) and a minimum water flow rate of 0.4 gpm (1.5 lpm).
- Water pressure of 40 psi (276 kPa) is required to achieve maximum flow rate.
- To maintain proper performance, there must be sufficient water supply pressure.

$$\begin{aligned} \text{Required Water Pressure} = & \\ & \text{Min. Operating Water Pressure} \\ & \quad (14 \text{ psi } [97 \text{ kPa}]) \\ & \quad + \text{ Pipe Pressure Loss} \\ & \quad + \text{ Faucet Pressure Loss} \\ & \quad + \text{ Safety Margin} \\ & \quad (\text{more than } 5 \text{ psi } [34 \text{ kPa}]). \end{aligned}$$

- To supply HOT water to upper floors, additional water pressure will be required (0.44 psi [3 kPa] per foot of height). Calculate the distance between the water inlet of the water heater (ground level) to the HOT water faucet farthest away from the water heater (upper floor level).
- Well water systems should be set to ensure a minimum system pressure of 40 psi (276 kPa). The pressure should remain constant and stable during the operation of the water heater.
- **Gravity water pressure is not recommended.** When the water is supplied from a water supply tank, the height of the tank, the diameter of the supply pipes, and their relation to water pressure need to be taken into consideration.

Water Supply Installation

NOTICES:

- Use only Teflon tape on all COLD and HOT water connections.
- If the water flow resistance of a showerhead is too high, the burner in the water heater will fail to ignite. Keep all showerheads clean from debris that could cause additional pressure drop.
- If using mixing valves on the outlet, choose one that prevents COLD water pressure from overcoming HOT water pressure.
- If multiple water heaters are installed in a manifold system, the water piping MUST be in “parallel” and the water pressure at each water heater should be 40 psi (276 kPa).

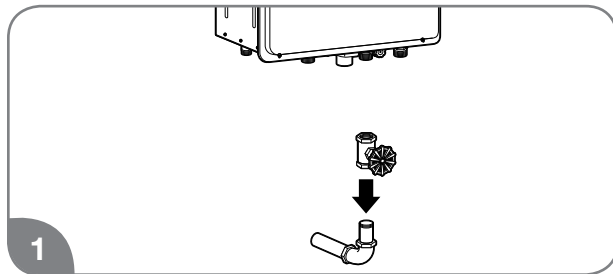

Install a COLD water shut-off valve near the inlet line on the water heater. This valve will be used for servicing and draining purposes.

NOTICE: It is not recommended to use pipes with smaller diameters than the water supply connection of the water heater.

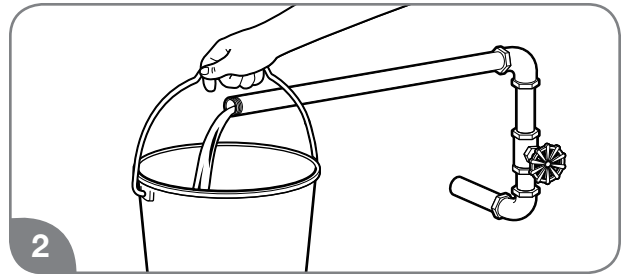

Before attaching the water line to the water heater, open the shut-off valve. Run the water until it has purged all contaminants (sand, debris, air, caulking, etc.).

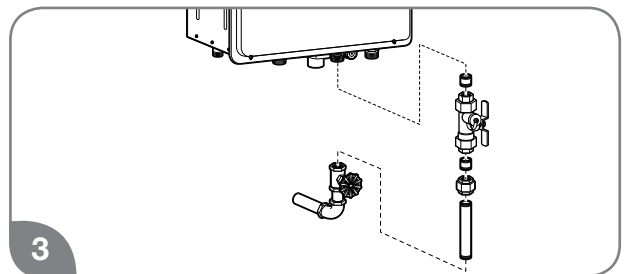

Install a service valve on the end of the COLD water supply line and connect it to the water inlet on the water heater.

INSTALLATION INSTRUCTIONS

Water Supply Installation (cont.)

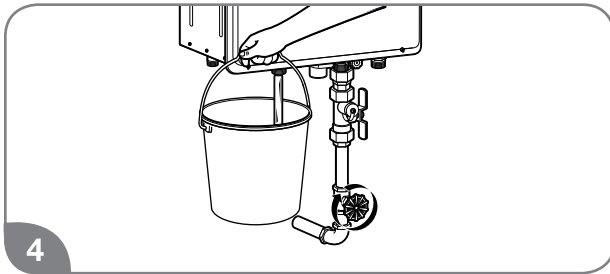

4
Open the shut-off valve in the COLD water Inlet line to check the water flow through the water heater.

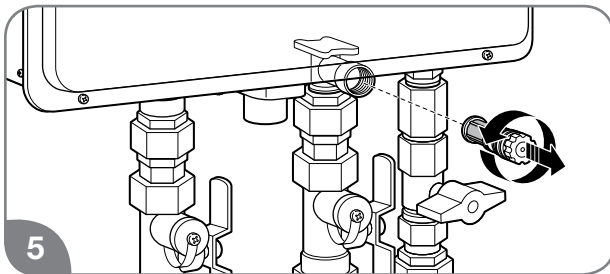

5
Close the shut-off valve and remove, clean, and replace the water filter.

NOTICES:

- Be sure to connect the COLD water inlet and the HOT water outlet as shown on the water heater. If reversed, the water heater will not function.
- The flow rate of HOT water may vary when more than two faucets (appliances, fixtures, etc.) are being used simultaneously.
- The pipes **MUST** be completely drainable. If the HOT water faucets are located at a point higher than the water heater, place a drain valve at the lowest point.

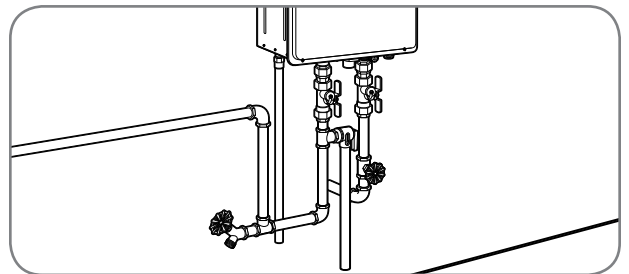

It is recommended to use unions and flexible copper connections at the COLD and HOT water lines. They allow the water heater to be disconnected easily for servicing.

Use the following guidelines when connecting the HOT WATER OUTLET:

- Connections between the water heater and point(s) of use should be as short as possible.
- Local codes shall govern the piping used for water connections.
- To conserve energy and to prevent freezing, insulate both COLD and HOT water supply lines.
Do not insulate drain line or pressure-relief valve.

Water Piping Arrangement With Service Valve Kit

Service valve kits are available on all tankless water heater systems. All kits include two full-port isolation valves to be used in the COLD and HOT water lines. When installed, these valves allow one person full diagnostic testing and ease of flushing the system. Contact your distributor or place of purchase for availability and installation information.

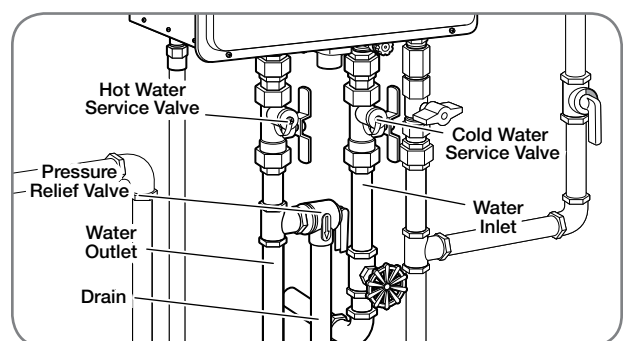

INSTALLATION INSTRUCTIONS



Water Supply (cont.)

Relief Valve

A new pressure-relief valve, complying with the Standard for Relief Valves and Automatic Gas Shut-Off Devices for Hot Water Supply Systems, ANSI Z21.22/CSA 4.4, must be installed at the HOT water outlet connection of the water heater during installation. Local codes shall govern the installation of any relief valves or place of purchase for availability and installation information.

NOTICES:

- The following drawing illustrates a pressure-only relief valve. If local codes require a combination temperature and pressure-relief valve, you may need to install an extension piece to ensure that the valve probe is not directly in the flow path of the water.
- If local codes require that a temperature and pressure-relief valve be installed, the manufacturer recommends a type 40XL Watts temperature and pressure-relief valve or equivalent model be used.
- Manual operation of relief valves should be performed at least once a year.
- If the relief valve on the system discharges periodically, a problem exists. Turn off the water heater, unplug the unit, and call for service.

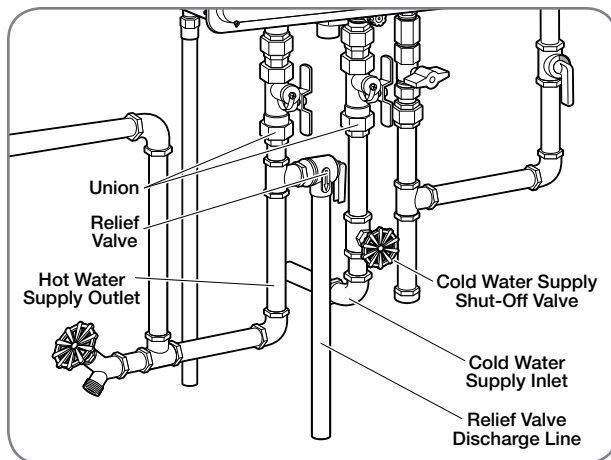

One end of the relief valve discharge line connects to the HOT water outlet pipe as shown above. The other end of the pipe should be routed to a suitable drain to eliminate potential water damage.

For safe operation of the water heater, be sure that:

- The pressure rating of the relief valve must not exceed 150 psi (1,034 kPa) or the maximum working pressure of the water heater. (See the rating plate on the water heater.)
- The BTUH rating of the relief valve must equal or exceed the BTUH input of the water heater. (See the rating plate on the water heater.)
- No valve of any type should be installed between the relief valve and the water heater.
- Discharge from the relief valve should be piped to a suitable drain. Piping used should be of a type approved for the distribution of hot water.
- HOT and COLD water lines should be insulated up to the water heater. See page 51.
- The discharge line must be NO SMALLER than the outlet of the relief valve. The drain line must pitch downward to allow for complete drainage of the line and the valve.
- The end of the discharge line should not be threaded or concealed and should be protected from freezing. No valve of any type, restriction, or reducer coupling should be installed in the discharge line.

INSTALLATION INSTRUCTIONS

Hot and Cold Pipe Insulation Installation

⚠️ WARNINGS:

- When pipe insulation is not rated for the appropriate weather conditions, install electric heat tracing or equivalent to prevent freezing of the pipes.
- Do not insulate or block drain valve on the hot outlet fitting.
- If pipes are allowed to freeze, the water heater and the pipes may malfunction or leak due to freezing water.

NOTICE: The hot and cold water supply pipes should be insulated to provide additional freeze protection.

For increased energy efficiency, use pipe insulation as shown in the diagram. Insulate the pipes all the way to the top. **DO NOT** cover any drain or pressure-relief valve(s).

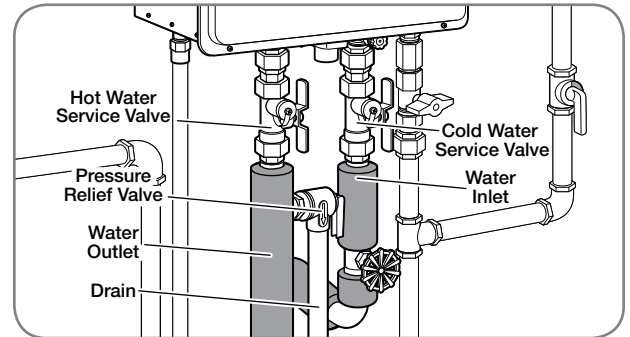

Condensate

Condensate Drainage

Be sure the condensate runs freely to a drain and does not accumulate inside the water heater. In cold climates, precautions may need to be taken to ensure that the condensate drain does not freeze.

- All condensation must drain and dispose of per local code.
- If the condensate drain gets blocked, an error code will display on the remote control. If this occurs, the condensate drain must be cleared.
- Use only PVC or CPVC pipe or flexible tube for the condensate drain line.

- The drain pipe (along its entire length) must be at least the same diameter as the drain line.
- The drain line should be as short as possible and have a downward slope toward the end.
- The end of the drain pipe should be open to the atmosphere. The end should not be under water or other substances.
- Do not connect the drain pipe directly to the drain sewer.
- Do not connect the drain pipe with an air-conditioning evaporator coil drain.

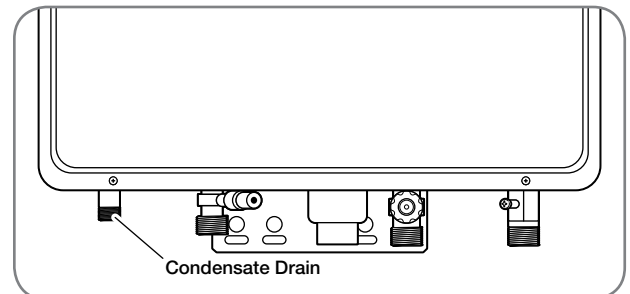
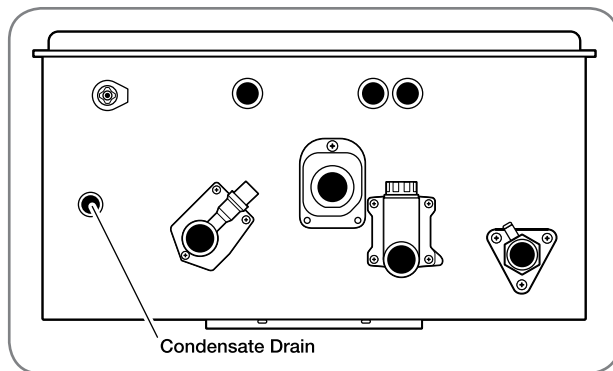

INSTALLATION INSTRUCTIONS

Gas Supply

Gas Supply Connections

⚠WARNING: Do not attempt to convert this water heater for use with a different type of gas other than the type shown on the rating plate. Doing so could result in death, personal injury, explosion or fire, product damage, and/or poor operating conditions or performance.

NOTICES:

- Gas piping shall be in accordance with local utility company requirements and/or in the absence of local codes, use the latest edition of National Fuel Gas Code (NFGC), ANSI Z223.1. In Canada, use the latest edition of CSA B149.1, National Gas and Propane installation code.
- Apply a thin coat of pipe compound to all threaded male ends. Compound must be of the type resistant to the action of LP gas.
- To ensure proper water heater operation, the gas pipe and gas meter must be sized correctly.

- If flexible connectors are used, the minimum inside diameter must be 3/4" or greater and the rated capacity of the connector must be equal to or greater than the BTU capacity of the water heater. See manufacturer information for the gas connector. Lengths over 36 inches are not recommended.
- Do not use excessive force (over 31.5 ft. lbs. [42,7 Nm]) when tightening the pipe sections. Excessive force can damage the water heater, especially when Teflon pipe compound is used.

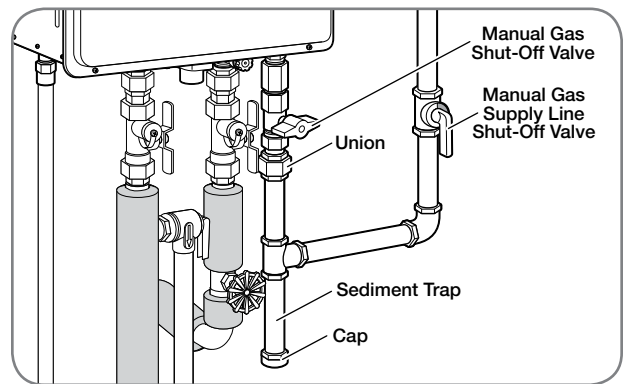

INSTALLATION INSTRUCTIONS

Gas Piping

Pipe-Sizing Procedure – Example

The gas supply must be capable of handling the entire gas load at the location. Gas line sizing is based on gas type, the pressure drop in the system, the gas pressure supplied, and gas line type. For gas pipe sizing in the United States, refer to the National Fuel Gas Code, NFPA 54. For Canadian gas pipe sizing, refer to the Natural Gas and Propane Installation Code CAN/CSA B149.1. The information below is provided as an example. The appropriate table from the applicable code must be used.

1. Determine the cubic feet per hour of gas required by dividing the gas input (on the rating plate) by the heating value of the gas (available from the local gas company). The gas input needs to include all gas products at the location and the maximum BTU usage at full load when all gas products are in use.

$$\text{Cubic Feet Per Hour (CFH)} = \frac{\text{Gas Input of Water Heater (BTU/HR)}}{\text{Heating Value of Gas (BTU/FT}^3\text{)}}$$

2. Use the table for your gas type to find the pipe size required for your cubic feet per hour of gas and your pipe length.

Example: The heating value of propane gas for your location is 2500 BTU/FT³. The gas input of the tankless water heater is 199,900 BTU/HR. Additional appliances at the location require 75,000 BTU/HR. Therefore, the cubic feet per hour = (199,900 + 75,000)/2500 = 109 FT³/HR. If the pipe length is 100 ft., then the 3/4-inch pipe size capable of supplying 197 FT³/HR of propane gas will be adequate.

Pipe-Sizing Table – Natural Gas				
Schedule 40 Metallic Pipe Inlet Pressure: Less than 2 psi (55 inches W.C.) Pressure Drop: 0.3 inches W.C. Specific Gravity: 0.60 (Capacity in cubic feet per hour)				
Length	Pipe Size (inches)			
	3/4	1	1 1/4	1 1/2
10	273	514	1060	1580
20	188	353	726	1090
30	151	284	583	873
40	129	243	499	747
50	114	215	442	662
60	104	195	400	600
70	95	179	368	552
80	89	167	343	514
90	83	157	322	482
100	79	148	304	455
125	70	131	269	403
150	63	119	244	366
175	58	109	224	336
200	54	102	209	313

Pipe-Sizing Table – Propane Gas				
Schedule 40 Metallic Pipe Inlet Pressure: 11.0 inches W.C. Pressure Drop: 0.5 inches W.C. Specific Gravity: 1.50 (Capacity in cubic feet per hour)				
Length	Pipe Size (inches)			
	1/2	3/4	1	1 1/4
10	291	608	1150	2350
20	200	418	787	1620
30	160	336	632	1300
40	137	287	541	1110
50	122	255	480	985
60	110	231	434	892
80	101	212	400	821
100	94	197	372	763
125	89	185	349	716
150	84	175	330	677
175	74	155	292	600
200	67	140	265	543

Refer to current National Fuel Gas Code, NFPA 54.

INSTALLATION INSTRUCTIONS

Gas Supply (cont.)

Gas Supply Installation

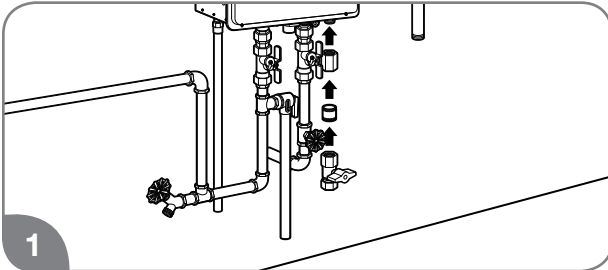

1
Install the manual gas appliance shut-off valve to the gas connection at the water heater. The shut-off is supplied with the water heater.

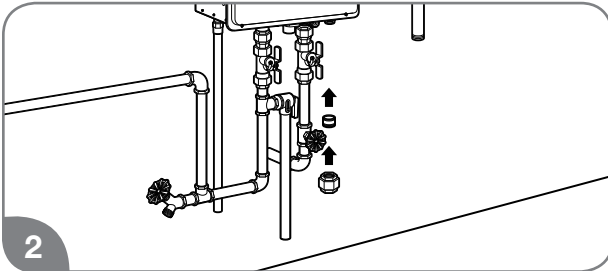

2
Install a ground joint union or ANSI design-certified semi-rigid or flexible gas appliance connector to the open end of the manual gas appliance shut-off valve. The (NFGC) ANSI Z223.1 and CSA B149.1 codes mandate the use of manual gas shut-off valves.

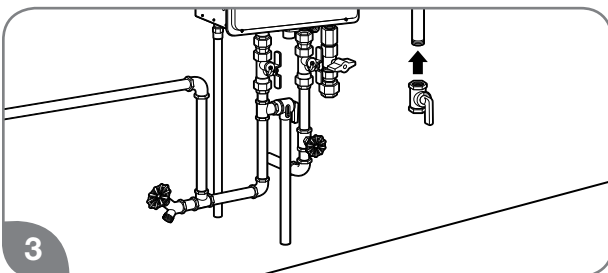

3
Install a manual gas supply line shut-off valve to the end of the gas supply line.

NOTICE: Lever-type gas shut-offs should all be T-handle type.

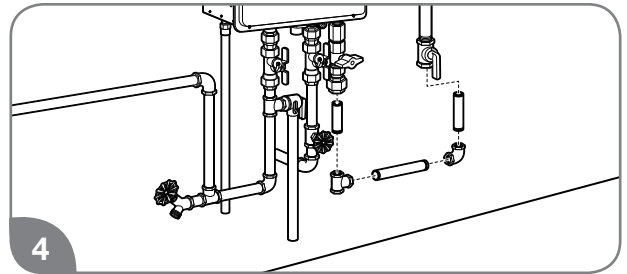

4
Using the proper-size piping, fittings, and components, build the gas supply line to the water heater.

NOTICE: The gas supply line should be a minimum of 3/4-in. (1.9-cm) black steel pipe or other approved gas piping material.

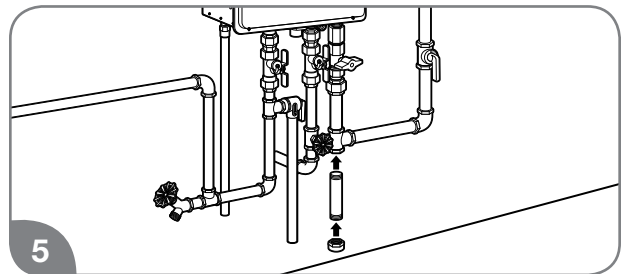

5
Install a sediment trap at the lowest portion of the gas line.

The inlet gas pressure to the water heater must NOT exceed 10.5 in. w.c. (2.6 kPa) for natural gas and 14 in. w.c. (3.5 kPa) for LP gas. For purposes of input adjustment, the minimum inlet gas pressure (with main burner on) is shown on the water heater rating plate. If high or low gas pressures are present, contact your gas supplier for correction.

INSTALLATION INSTRUCTIONS

Leak Testing

⚠WARNING: Never use an open flame to test for gas leaks, because death, personal injury, and/or property damage can result.

The water heater and its gas connections **MUST** be leak-tested at normal operating pressures before the unit is placed in operation. These tests should also include all factory connections.

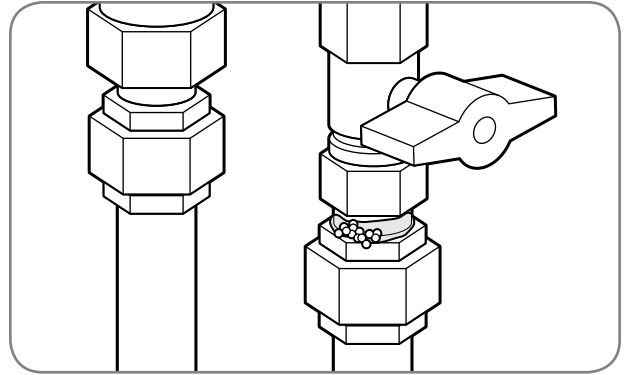

Turn on the gas shut-off valve(s) to the water heater.

Use a soapy water solution to test for leaks at all the connections and fittings. If bubbles are seen, it indicates a gas leak that must be corrected.

Contact a qualified service technician.

Pressure Testing the Gas Supply System

⚠CAUTION: Install a gas pressure regulator in the gas supply line. This regulator should not exceed the maximum supply pressure. **DO NOT** use an industrial-type gas regulator.

The water heater and its manual gas shut-off valve must be disconnected from the gas supply piping system whenever the pressure testing will exceed 1/2 psi (14 in. w.c. [3.5 kPa]).

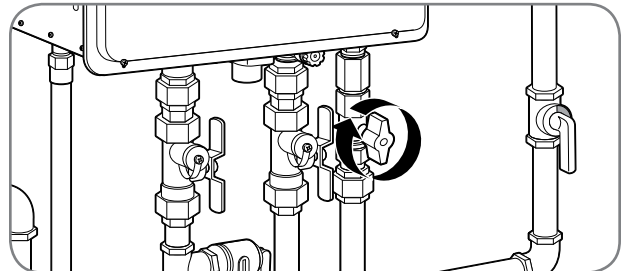

The water heater must be isolated from the gas piping system whenever the pressure testing will be less than and/or up to 1/2 psi (14 in. w.c. [3.5 kPa]). Closing the manual gas shut-off valve will isolate the water heater from the gas piping system.

INSTALLATION INSTRUCTIONS



Gas Supply (cont.)

High-Altitude Installation

The water heater is certified for installations up to 3,280 ft. (1,000 m) above sea level. The input rating of this water heater is based on sea level operation. At higher elevations, the actual input rate may be lower than the value listed on the rating label.

NOTICES:

- For installations above 3,280 ft. (1,000 m) elevation, contact a qualified service technician to make the proper altitude adjustments. See pages 67 and 68 for additional information.
- Do not install this water heater at elevations above 3,280 ft. (1,000 m) without the proper adjustments. Please contact your installer, local gas supplier, place of purchase, or the Rheem Customer Service phone number listed on page 26 in the “Call for Assistance” section.



Electrical Wiring

⚠ DANGER: Shock Hazard – Before servicing the water heater, turn off the electrical power to the water heater at the main disconnect or circuit breaker. Failure to do so will result in death or serious personal injury.

⚠ WARNING: Field wiring connections and electrical grounding must comply with local codes or, in the absence of local codes, with the latest edition of the National Electrical Code, ANSI/NFPA 70, in the U.S., or Canadian Electrical Code, CSA C22.1, Part 1, in Canada.

⚠ CAUTION: Label all wires prior to disconnecting. Wiring errors can cause personal injury, product damage, and/or dangerous operating conditions. Verify correct operation after servicing.

NOTICES:

- Do not connect power until venting installation is complete (see Venting Installation pages 34–46).
- Wait ninety (90) seconds after power is connected for the first time to initiate operation of the water heater.

Power Cord

- The electric power supply requirement for this water heater is 120 VAC/60 Hz, 2 amps.
- A dedicated circuit is recommended for the water heater. Do not connect to a GFCI or AFCI circuit. Multiple units may be connected to a single circuit up to the circuit rating.
- Do not use 3-prong to 2-prong adapters. Do not use power strips or multiple outlet adapters.

- All direct-vent gas models come with a three-prong power cord. Only use this power cord and a matching grounded electrical outlet.
- All outdoor gas models do not come with a power cord. Only hard-wire to an appropriate power outlet with a ground terminal.
- Keep any excess length of the power supply cord on the outside of the water heater.
- If local codes require hard-wiring, see instructions for “Hard-Wiring the Electrical Connections” below.

Hard-Wiring the Electrical Connections

- Wiring should be performed by a qualified electrician in accordance with local codes.
- The water heater requires a properly grounded 120 VAC/60 Hz dedicated power supply. Multiple water heaters may be connected to a single circuit up to that circuit’s rating.
- DO NOT connect grounding wire to water pipes, gas pipes, telephone cables, lighting conductor circuits, or to any other grounding circuits that require a GFCI or AFCI (arc fault circuit interrupter).
- An ON/OFF switch must be provided and installed for the incoming 120 VAC power supply.
- Wire the water heater exactly as shown in the wiring diagram. This wiring diagram can also be found inside the water heater cover panel.
- The green screw is provided in the enclosure for a grounding connection.
- Connect the live wire to the black wire and neutral wire to the white neutral wire.

INSTALLATION INSTRUCTIONS

Wiring Diagram

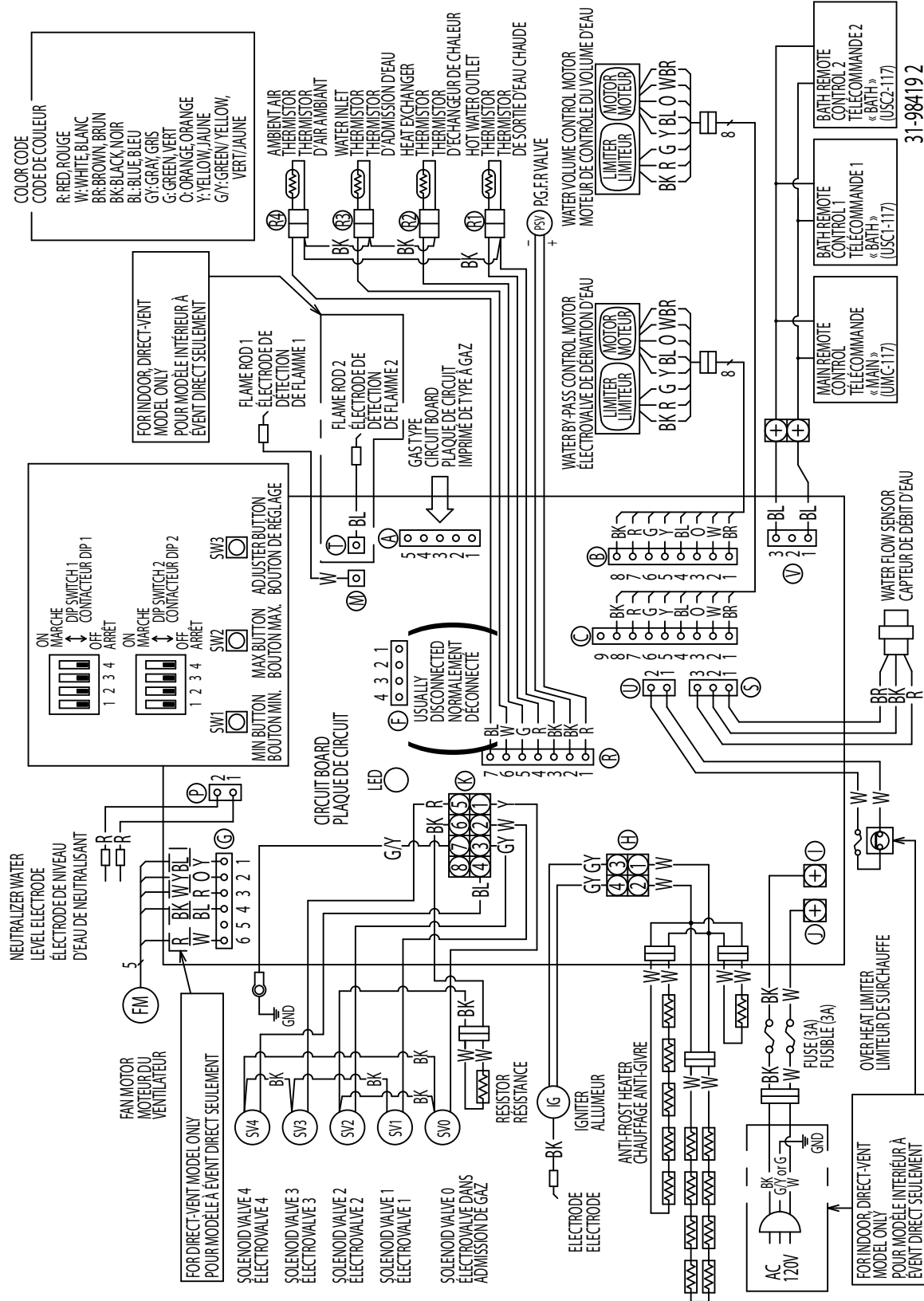

Electrical

INSTALLATION INSTRUCTIONS



Electrical Wiring (cont.)

Remote Control Selection and Location

⚠ WARNING: Field wiring connections and electrical grounding must comply with local codes or, in the absence of local codes, with the latest edition of the National Electrical Code, ANSI/NFPA 70, in the U.S., or Canadian Electrical Code, CSA C22.1, Part 1, in Canada.

NOTICES:

- The provided remote control will allow maximum temperature settings of 120°F (49°C). Temperatures up to 140°F (60°C) for residential applications and up to 185°F (85°C) for commercial applications* can be achieved with the MAIN (UMC-117) remote control. Only qualified service personnel should perform this adjustment.

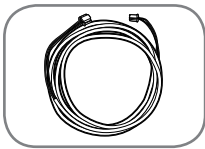

- An optional cable (EZ Link Cable™) can be purchased separately to manifold two water heaters together.



- Do not** attempt to disassemble a remote control. All controls are sealed and calibrated for accurate water heater control and operation.

One remote control is provided with the water heater. Additional remote controls may be purchased separately. The available remote controls are listed in the following chart. Up to three remote controls can be used with the water heater. **No other manufacturer's controls are suitable for use with this water heater.**

Review the following considerations before determining the location of the remote control(s):

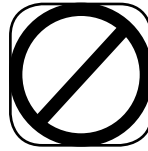

- Do not** install any remote control outdoors or where it can come in contact with water.



- Avoid installing the remote control in the following areas and/or conditions:
 - area exposed to heat.
 - area exposed to steam.
 - area exposed to oil.
 - area exposed to direct sunlight.
 - areas near stored or used flammable products.

- Place remote control out of children's reach.
- The remote control should be installed in a convenient location (e.g., kitchen, laundry room, utility room, or directly next to the water heater).
- The maximum distance between the water heater and the remote control installation location is limited to 195 ft. (59 m) of wire.

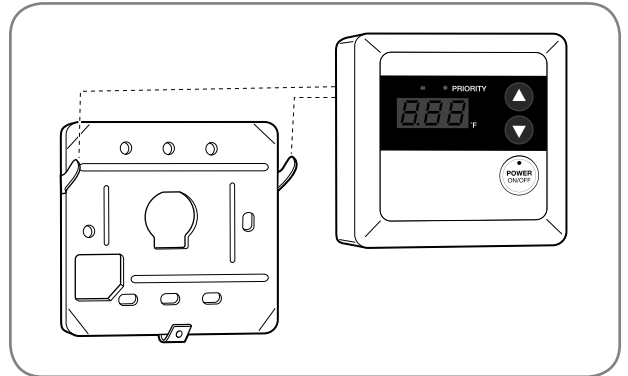

Remote Control Model Number	Remote Control Description	Temperature Set Point Range	Availability
UMC-117	MAIN	100°F–120°F (38°C–49°C)	Factory Default
		85°F (29°C) 125°F–140°F (52°C–60°C)	Qualified Technician Adjustment for Residential Products
		85°F (29°C) 125°F–185°F (52°C–85°C)	Qualified Technician Adjustment for Commercial Products*
USC1-117	BATH 1	100°F–120°F (38°C–49°C)	Optional (Sold Separately)
		85°F (29°C)	Qualified Technician Adjustment
USC2-117	BATH 2	100°F–120°F (38°C–49°C)	Optional (Sold Separately)
		85°F (29°C)	Qualified Technician Adjustment
MIC-6 or MIC-185** Manifold System	Manifold System		Optional (Sold Separately)

*A commercial conversion kit can be purchased to achieve temperatures up to 185°F (85°C).

**When a manifold system is installed, the main remote control connected to the manifold controller (MIC-6 or MIC-185) has priority over the remote controls connected to the water heater.

INSTALLATION INSTRUCTIONS

Remote Control Installation

⚠ WARNING: Field wiring connections and electrical grounding must comply with local codes or, in the absence of local codes, with the latest edition of the National Electrical Code, ANSI/NFPA 70, in the U.S., or Canadian Electrical Code, CSA C22.1, Part 1, in Canada.

NOTICES:

- Remote control cable can be any Type-T 18 AWG wire similar to a thermostat wire and need not be polarity-sensitive.
- It is not recommended to have wiring exposed.
- **Do not** apply sealant to remote control cable.
- **Do not** use network cable, telephone wire, or any twisted-pair cable.

Connecting the MAIN (UMC-117) Remote Control to a Wall:

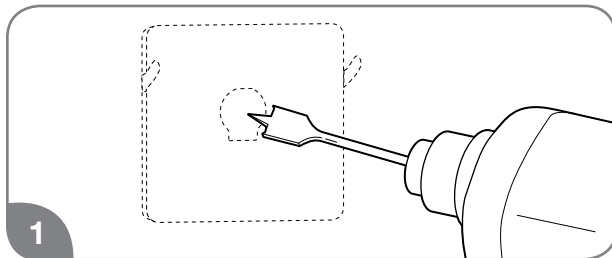

Drill a 1- to 1 1/2-in. (2.5/3.8-cm) hole at the proposed control location. Install the remote control cable between the location of the remote control and the water heater.

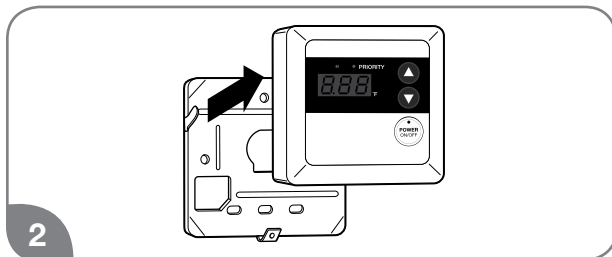

Remove the remote control from the base plate.

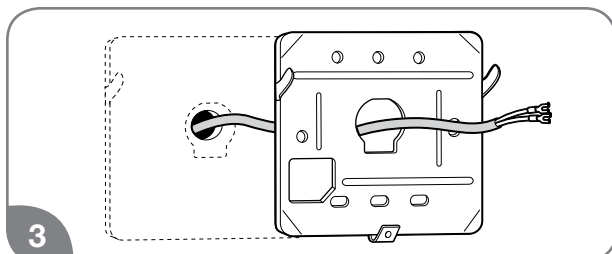

Feed the remote control cable through the large center hole in the base plate.

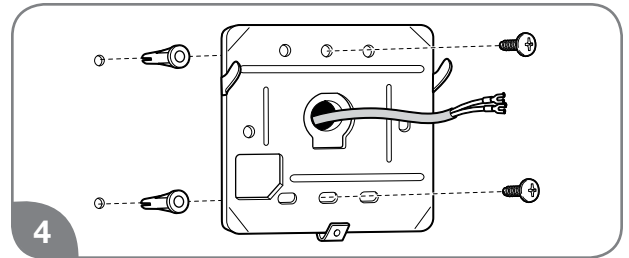

Install the base plate to the wall using suitable screws and wall anchors.

NOTICE: The tabs on the base plate should always point out.

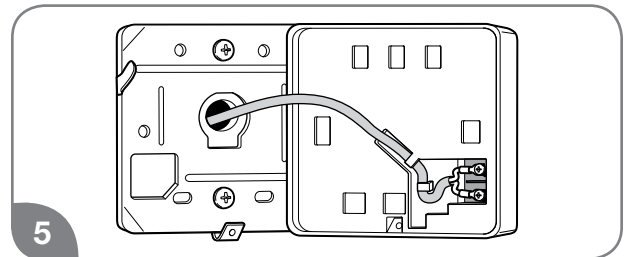

Connect the remote control to the remote control cable.

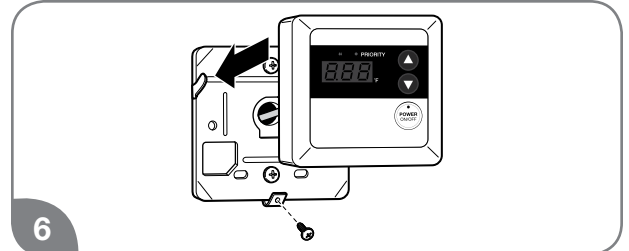

Position the remote control on the base plate.

NOTICE: The tabs on the base plate should line up with the slots on the back of the control panel.

Secure the control panel to the base plate with one screw into the bottom tab.

NOTICE: Do not attempt to connect the remote control or control wire to the water heater while the water heater has power applied to it. Damage to the water heater will occur. Do not cut or strip the wiring while it is connected to the water heater or while the water heater has power applied to it.

INSTALLATION INSTRUCTIONS

Electrical Wiring (cont.)

Connecting the Remote Control to the Water Heater:

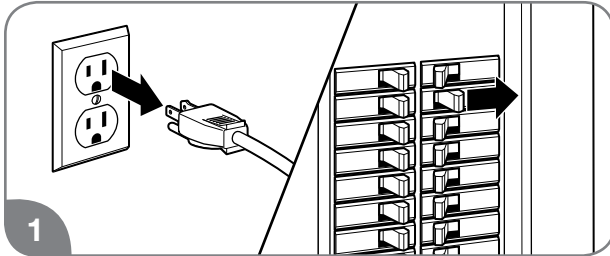

1

Ensure that the power to the water heater has been disconnected.

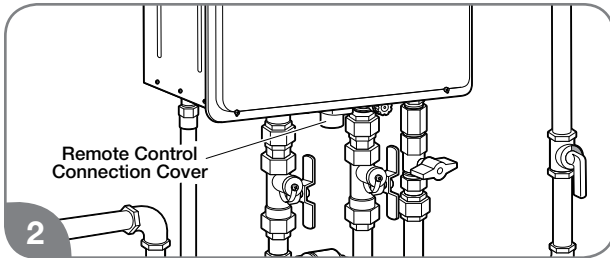

2

Loosen the one screw located on the remote control connection cover. The connection cover is made of white plastic.

NOTICE: DO NOT REMOVE FRONT PANEL. Remote control wires are connected on the bottom of the unit.

There are no accessible remote control terminals inside the water heater.

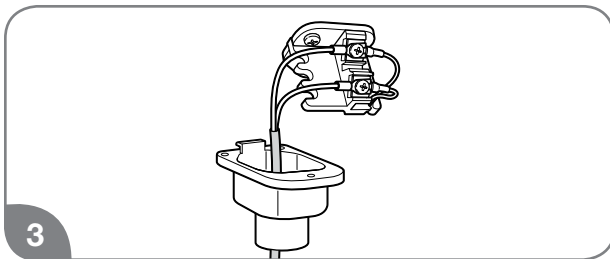

3

Connect the remote control extension cables from the remote control to the remote control connection terminals.

NOTICE: The remote control wire connection terminals are not polarity-sensitive.

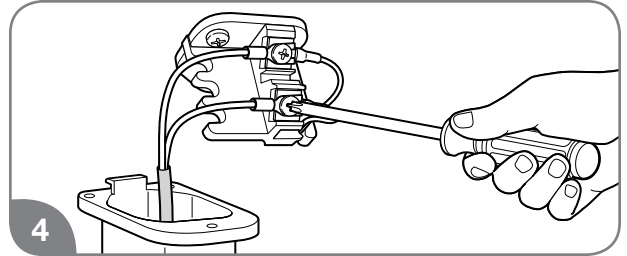

4

Firmly tighten the terminal screws by hand. Secure the remote control extension cable on

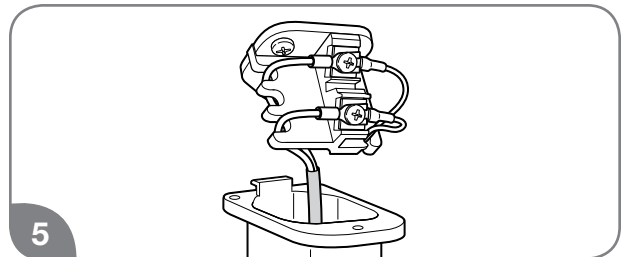

5

the hook located on the side of the remote control connection base. Reinstall the remote control connection cover

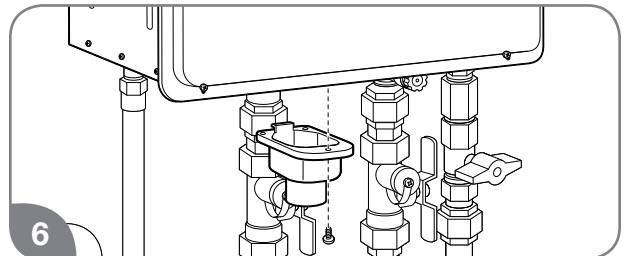

6

and secure with the one screw.

NOTICE: Do not connect power until venting installation is complete. Switch on the power supply to the water heater.

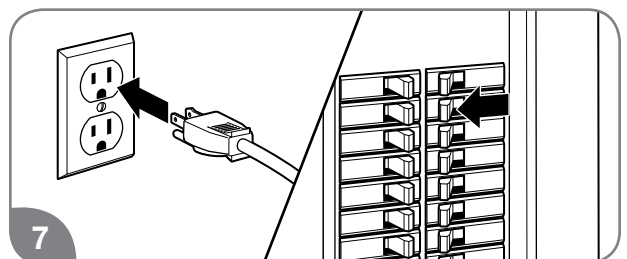

7

Check for proper operation of the remote control and the water heater.



Insulation Blankets

In general, insulation blankets for external use on gas water heaters are **not necessary**. The purpose of an insulation blanket is to reduce the standby heat loss from the water heater's storage tank. Since these water heaters do not store water, they eliminate the need for the insulation blanket.

⚠️ WARNINGS:

- If local codes require the application of external insulation blanket kits, carefully follow the manufacturer's installation instructions included with the kit. Only use blanket kits that are approved for use with your water heater.
- **NEVER** cover the air inlet, flue outlet, or operating and warning labels attached to the water heater. Operating and warning labels should not be relocated to the exterior of an insulation blanket. Covering these components will cause dangerous operating conditions that can lead to death, personal injury, property damage, and/or product damage.

The manufacturer's warranty does not cover any damage or defect caused by insulation, insulation attachment, or use of any type of energy-saving or other unapproved devices (unless authorized by the manufacturer). The use of unauthorized energy-saving devices can result in death, personal injury, and/or property damage. The manufacturer disclaims any responsibility for such loss or injury resulting from the use of such unauthorized devices.



Installation Precautions

- Follow all installation instructions covered in this manual.
- Check the inlet gas pressure to make sure it is within the range specified on the rating plate.
- Make sure there is adequate air for combustion and ventilation as described on pages 37–38 or page 44 in this manual.
- Maintain proper clearances to combustibles and noncombustibles as specified on the rating plate.
- Make sure the venting system complies with local codes, National Fuel Gas Codes (ANSI Z223.1/NFPA 54) or CSA B149.1, and the guidelines found on pages 34 through 46 in this manual.
- Contact the local gas company to make sure the gas meter and gas piping are adequately sized.
- Use only Teflon tape on all male water line connections and fittings.
- **Do not** block or restrict any air intake openings.
- **Do not** remove the front cover unless absolutely necessary. This should only be done by a qualified service technician.
- **Do not** install this product where standing water may occur.
- **Do not** use pipe dope on water line connections and fittings.

INSTALLATION INSTRUCTIONS



Installation Checklist

A. Water Heater Location

- Indoor water heaters must be installed indoors.
- Outdoor water heaters must be installed outdoors.
- Close to area of ventilation termination (indoor models).
- Protected from freezing temperatures.
- Proper clearance from combustible material observed.
- Sufficient fresh air supply for proper operation of water heater.
- Air supply free of corrosive elements and flammable vapors.
- Provisions made to protect area from water damage.
- Sufficient room to service heater.
- Combustible materials, such as clothing, cleaning materials, and rags, clear of the heater and vent piping.
- Water heater is properly attached to the wall.

B. Vent (Indoor Models)

- Vent pipe material is PVC and is manufacturer-approved.
- Horizontal air intake and exhaust pipes have a 1/4" per foot DOWNWARD slope toward the vent terminal.
- Vertical venting is installed as described on pages 43 and 44.
- Connection(s) securely fastened together with cement and airtight.
- All vent runs are properly installed.
- Vent terminal is properly installed.
- Maximum vent length is observed.

C. Water Supply/Relief Valve

- Water supply has sufficient pressure.
- Air has been purged from the water heater and the piping.
- Water connections tight and free from leaks.
- Water filter is clean and in place.
- All piping has been assembled as described on pages 48 and 49.
- Water pipes are insulated and protected from freezing, if necessary.
- Pressure-relief valve properly installed with discharge line running to open drain.
- Discharge line protected from freezing, if necessary.

D. Gas Supply

- Gas type matches listing on rating plate.
- Gas supply pressure is sufficient for the water heater.
- Gas line equipped with shut-off valve, union and sediment trap as described on page 54.
- Approved pipe-joint compound has been used on all gas pipe connections.
- All connections and fittings have been checked for leaks with a soapy water solution.
- Gas company inspected installation (if required).

E. Electrical Wiring

- Supply cord and/or wiring meets all local codes, National Electrical Code, ANSI/NFPA 70, in the U.S., or Canadian Electrical Code, CSA C22.1, Part 1, in Canada.
- Voltage matches listing on rating plate.
- Water heater is properly grounded.

F. Condensate

- Condensate drain is properly installed.

INSTALLATION INSTRUCTIONS



Lighting the Water Heater

⚠WARNING: Before operating this water heater, be sure to read and follow the instructions on the following label, all labels on the water heater, and the "Important Safety Information" section in this manual. Failure to do so can result in unsafe operating conditions that can result in death, personal injury, property damage, and/or product damage.

NOTICE: If you have any problems reading or following the instructions in this manual, **STOP** and call a qualified service technician or contractor.

FOR YOUR SAFETY READ BEFORE OPERATING

WARNING : If you do not follow these instructions exactly, a fire or explosion may result causing property damage, personal injury or loss of life.

- A. This appliance does not have a pilot. It is equipped with an ignition device which automatically lights the burner. Do not try to light the burner by hand.
- B. BEFORE OPERATING smell all around the appliance area for gas. Be sure to smell next to the floor because some gas is heavier than air and will settle on the floor.
WHAT TO DO IF YOU SMELL GAS
 - Do not try to light any appliance. ● Do not touch any electric switch; do not use any phone in your building. ● Immediately call your gas supplier from a neighbor's phone. Follow the gas supplier's instructions. ● If you cannot reach your gas supplier, call the fire department.
 - Do not return to your home until authorized by the gas supplier or fire department.
- C. Use only your hand to push in or turn the gas control knob. Never use tools. If the knob will not push in or turn by hand, don't try to repair it, call a qualified service technician. Force or attempted repair may result in a fire or explosion.
- D. Do not use this appliance if any part has been under water. Immediately call a qualified service technician to inspect the appliance and to replace any part of the control system and any gas control which has been under water.

OPERATING INSTRUCTIONS

1. STOP! Read the safety information above on this label.
2. Turn off all electric power to the appliance.
3. Do not attempt to light the burner by hand.
4. Turn the Gas Shutoff Valve located on the outside of the unit clockwise ↻ to the "OFF" position.
5. Wait five (5) minutes to clear out any gas. If you then smell gas, STOP! Follow "B" in the safety information above on this label. If you don't smell gas, go to the next step.
6. Turn the Gas Shutoff Valve located on the outside of the unit counterclockwise ↻ to the "ON" position.
7. Turn on all electric power to the appliance.
8. If the appliance will not operate, follow the instructions "To Turn Off Gas To Appliance" and call your service technician or gas supplier.

GAS SHUTOFF VALVE



OPEN



CLOSE

TO TURN OFF GAS TO APPLIANCE

1. Turn off all electric power to the appliance if service is to be performed.
2. Turn the Gas Shutoff Valve located on the outside of the unit clockwise ↻ to the "OFF" position.

INSTALLATION INSTRUCTIONS

Lighting the Water Heater

Operating Instructions

Read, understand, and follow the safety information listed on the operating label on page 63 and in the “*Important Safety Information*” section in this manual.

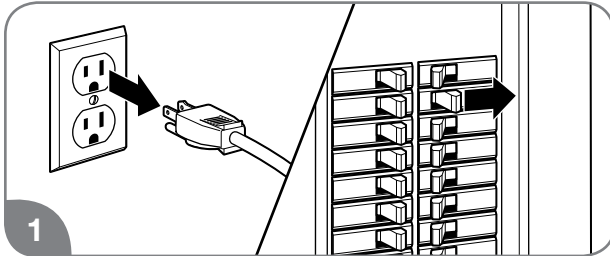

Disconnect all electric power to the water heater.

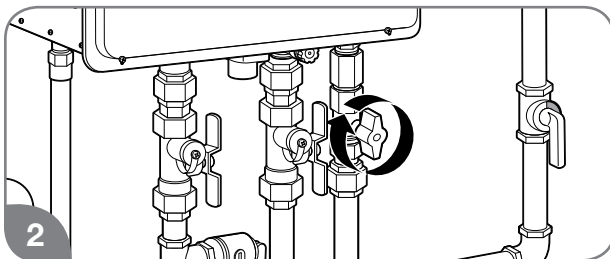

Turn the gas shut-off valve clockwise to the OFF position. This valve is located on the outside of the water heater. Wait 5 minutes to clear any gas. If you don't smell gas, proceed to Step 3.

NOTICE: If you smell gas, STOP and follow the safety instructions listed under B on the operating label or on the front cover of this manual.

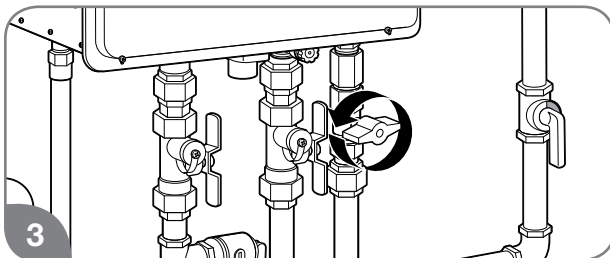

Turn the gas shut-off valve counterclockwise to the ON position.

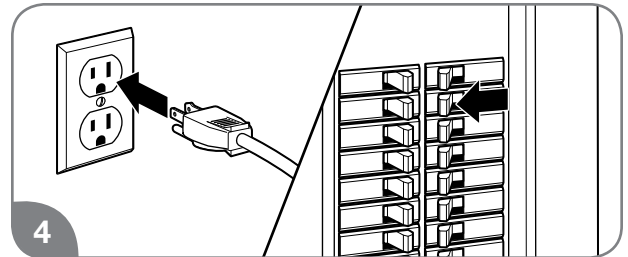

Turn on all electric power to the water heater. The water heater burner will automatically light when there is a demand for hot water.

⚠ WARNING: Do not attempt to light the burner by hand. Lighting the burner by hand is an unsafe operating condition that can result in death, personal injury, property damage, and/or product damage.

If the water heater burner will not light, turn off the water heater as described below and call your service technician or gas supplier.

Shutting Off the Water Heater

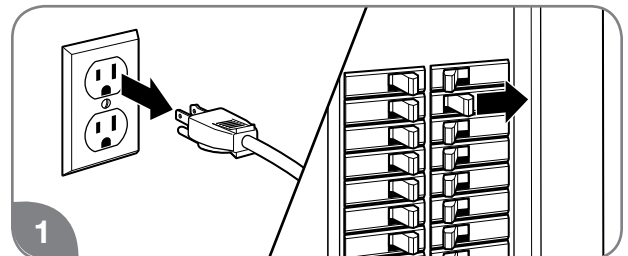

Disconnect all electric power to the water heater.

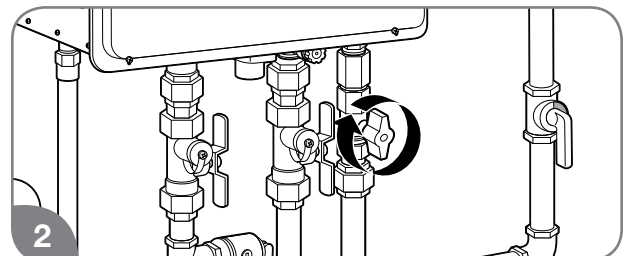

Turn the gas shut-off valve clockwise to the OFF position.

INSTALLATION INSTRUCTIONS

The contents on pages 65 through 68 should only be performed by qualified service personnel.



Setting the Water Temperature

⚠️ WARNING: Improper adjustment, alteration, service, or maintenance can result in death, personal injury, property damage, and/or product damage.

Maximum Temperature Adjustment by the Main Remote Control (UMC-117)

⚠️ DANGER: Water temperatures above 125°F (52°C) will result in death and/or severe burns from scalding.

⚠️ WARNING: Refer to chart below and the scald potential warnings on page 4 on this manual before making an adjustment. Changing this setting is done at your own risk.

Time/Temperature Relationship in Scalds

Water Temperature	Time to Produce a Serious Burn
120°F (49°C)	More than 5 minutes
125°F (52°C)	1 1/2 to 2 minutes
130°F (54°C)	About 30 seconds
135°F (57°C)	About 10 seconds
140°F (60°C)	Less than 5 seconds
145°F (63°C)	Less than 3 seconds
150°F (66°C)	About 1 1/2 seconds
155°F (68°C)	About 1 second

Table courtesy of Shriners Burn Institute

Residential water heater temperatures can be adjusted up to 140°F (60°C). **Do not perform the following adjustment if a setting of up to 140°F (60°C) is not required.**

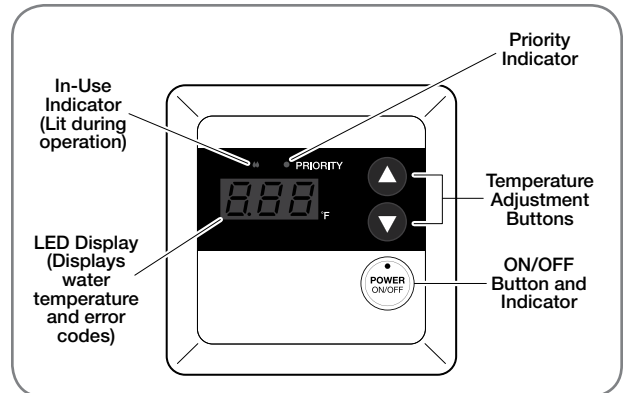

To change the temperature settings up to 140°F (60°C):

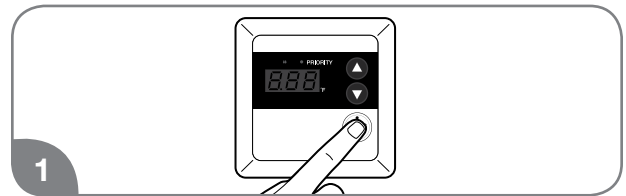

Turn on the remote control.

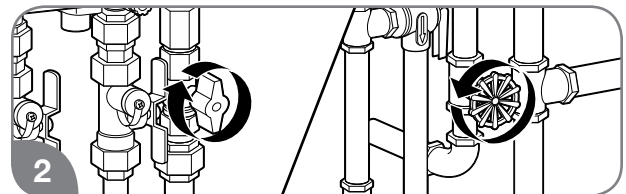

Turn off the gas and water to the water heater by closing the shut-off valves.



Press the UP adjustment button repeatedly until 120°F (49°C) shows in the LED display. Hold the UP button until the "120" on the display starts to blink.

NOTICE: LED display only shows °F.

Start/Adjust

INSTALLATION INSTRUCTIONS

Setting the Water Temperature (cont.)



While “120” is blinking, press the UP and DOWN adjustment buttons at the same time. “120” will stop blinking.



Press the UP or DOWN adjustment button to set the desired temperature.

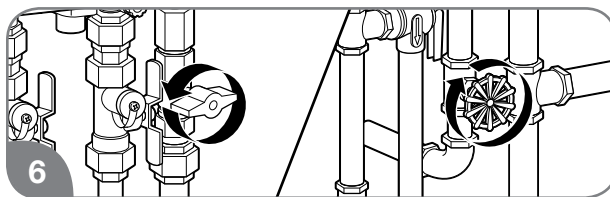

Turn on the gas and water to the water heater by opening the shut-off valves.

To limit maximum water temperature setting to 120°F (49°C):

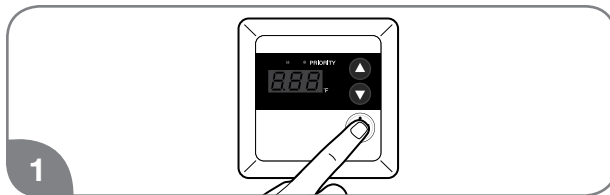

Turn on the remote control.

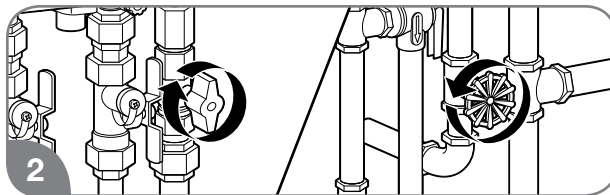

Turn off the gas and water to the water heater by closing the shut-off valves.



Press the DOWN adjustment button repeatedly until 100°F (38°C) or 85°F (29°C) shows in the LED display. Hold the DOWN button until the number on the display starts to blink.



While the number is blinking, press the UP and DOWN adjustment buttons at the same time. The number will stop blinking.



Press the UP or DOWN adjustment button to set the desired temperature.

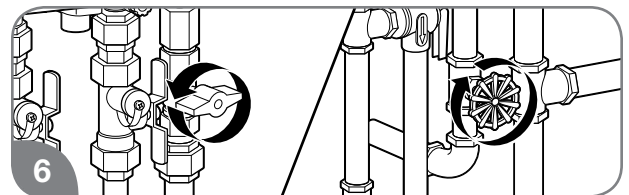

Turn on the gas and water to the water heater by opening the shut-off valves.

INSTALLATION INSTRUCTIONS

Minimum Temperature Adjustment by the Main Remote Control (UMC-117, USC1-117, and USC2-117)

Residential water heater temperatures can be adjusted down to 85°F (29°C), when required. **To change the temperature settings down to 85°F (29°C):**



1 Turn on the remote control.

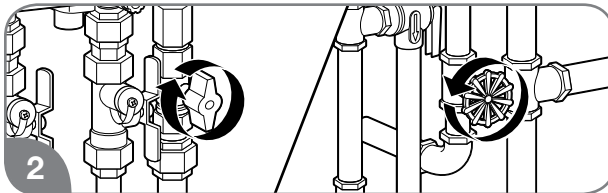

2 Turn off the gas and water to the water heater by closing the shut-off valves.



3 Press the DOWN adjustment button repeatedly until 100°F (38°C) shows in the LED display.

NOTICE: LED display only shows °F.



4 Press the DOWN adjustment button 3 times within 5 seconds. The display will show "85."

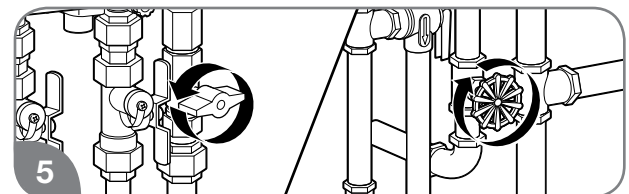

5 Turn on the gas and water to the water heater by opening the shut-off valves.

NOTICE: The maximum flow rate at 85°F (29°C) is 1.3 gpm (5.0 L/m).

High-Altitude DIP Switch Adjustments

When the water heater is installed above 3,280 ft. (1,000 m), the settings on the DIP switch located on the printed circuit board (PCB) need to be changed. If these settings are not changed, the water heater may not function properly.

NOTICE: If the water heater is installed under 3,280 ft. (1,000 m) altitude, no action is required.

Verify the altitude that the water heater is installed.

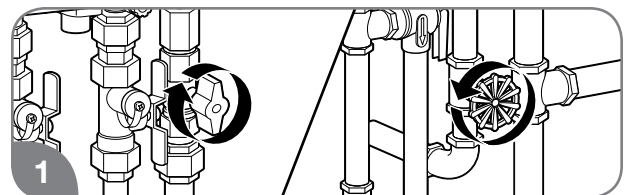

1 Turn off the gas and water to the water heater by closing the shut-off valves. The OFF position is DOWN.

INSTALLATION INSTRUCTIONS



High-Altitude DIP Switch Adjustments (cont.)

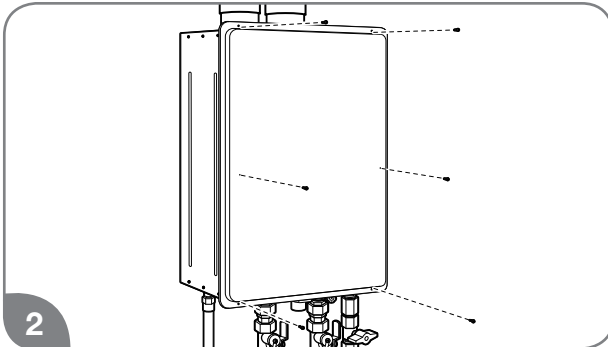

Remove the front cover panel on the water heater.

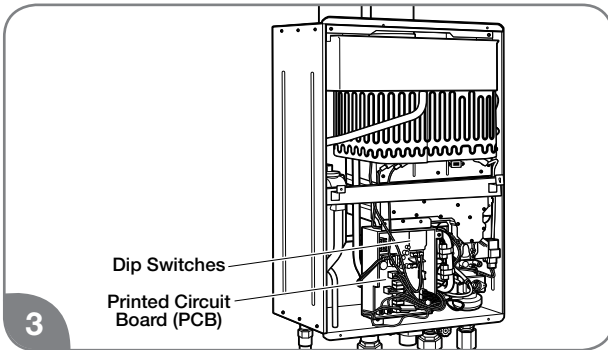

Dip Switches
Printed Circuit Board (PCB)

Find DIP Switch 2 located in the top-right portion of the PCB. The switch labeled “DIP 2” is the bottom switch.

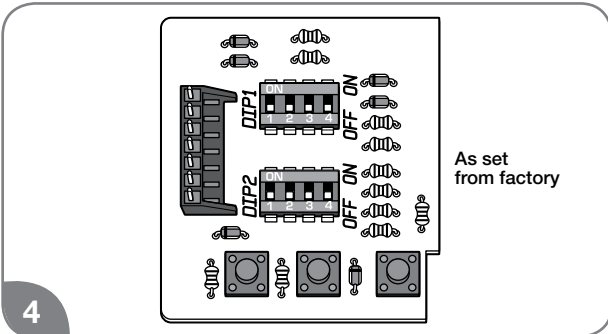

As set from factory

The factory settings for this switch should all be in the OFF position (DOWN).

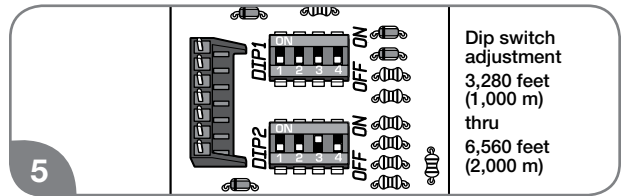

Dip switch adjustment
3,280 feet
(1,000 m)
thru
6,560 feet
(2,000 m)

If altitude is above 3,280 ft. (1,000 m) and below 6,560 ft. (2,000 m), change the third switch on “DIP 2” to the ON position (UP).

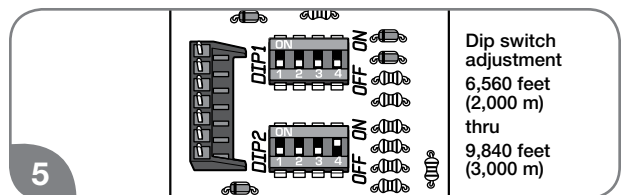

Dip switch adjustment
6,560 feet
(2,000 m)
thru
9,840 feet
(3,000 m)

If altitude is above 6,560 ft. (2,000 m) and below 9,840 ft. (3,000 m), change the fourth switch to the ON position (UP).

NOTICE: Do not alter any other DIP switch settings. The manifold pressure will be reduced accordingly.

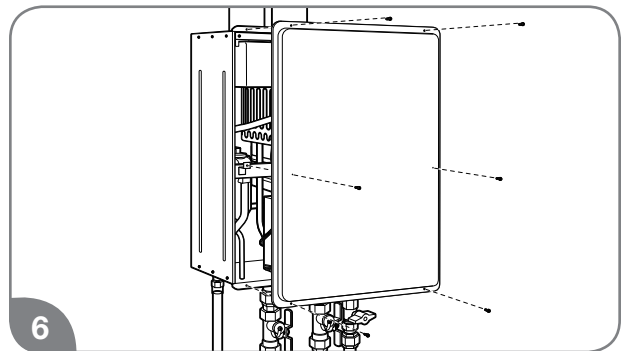

Replace the front cover panel.

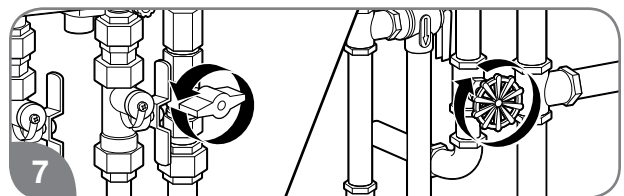

Turn on the gas and water to the water heater by opening the shut-off valves.



Parts Ordering

⚠ WARNING: For your safety, do not attempt to disassemble, repair, or replace any portion of this unit. Refer all repairs, service, and/or adjustments to qualified service personnel.

Address all parts orders to the distributor or store where the water heater was purchased. All parts orders should include:

1. The model and serial number of the water heater from the rating plate.
2. Specify the gas type (natural or LP) as marked on the rating plate.
3. Parts description (as shown below) and number of parts desired.

Direct-Vent Gas Components

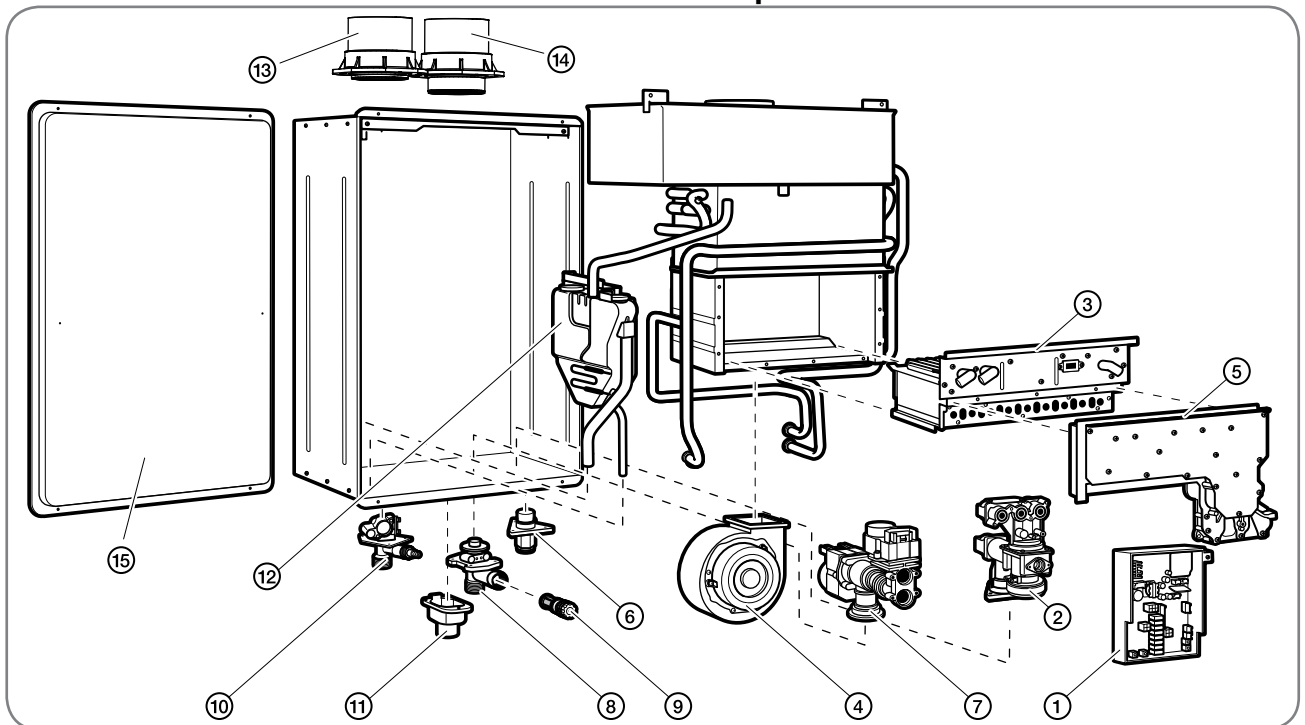

Ref #	Description
1	Control Board
2	Gas Valve
3	Burner Assembly
4	Blower Motor
5	Burner Manifold
6	Gas Inlet Connector
7	Water Control Body
8	Water Inlet Connector 3/4"
9	Drain Relief Valve
10	Hot Outlet Connector
11	Remote Control Terminal Block
12	Neutralization kit
13	Air Intake Connector
14	Flue Connector
15	Front Cover

PARTS REPLACEMENT

Parts Ordering (cont.)

Outdoor Gas Components

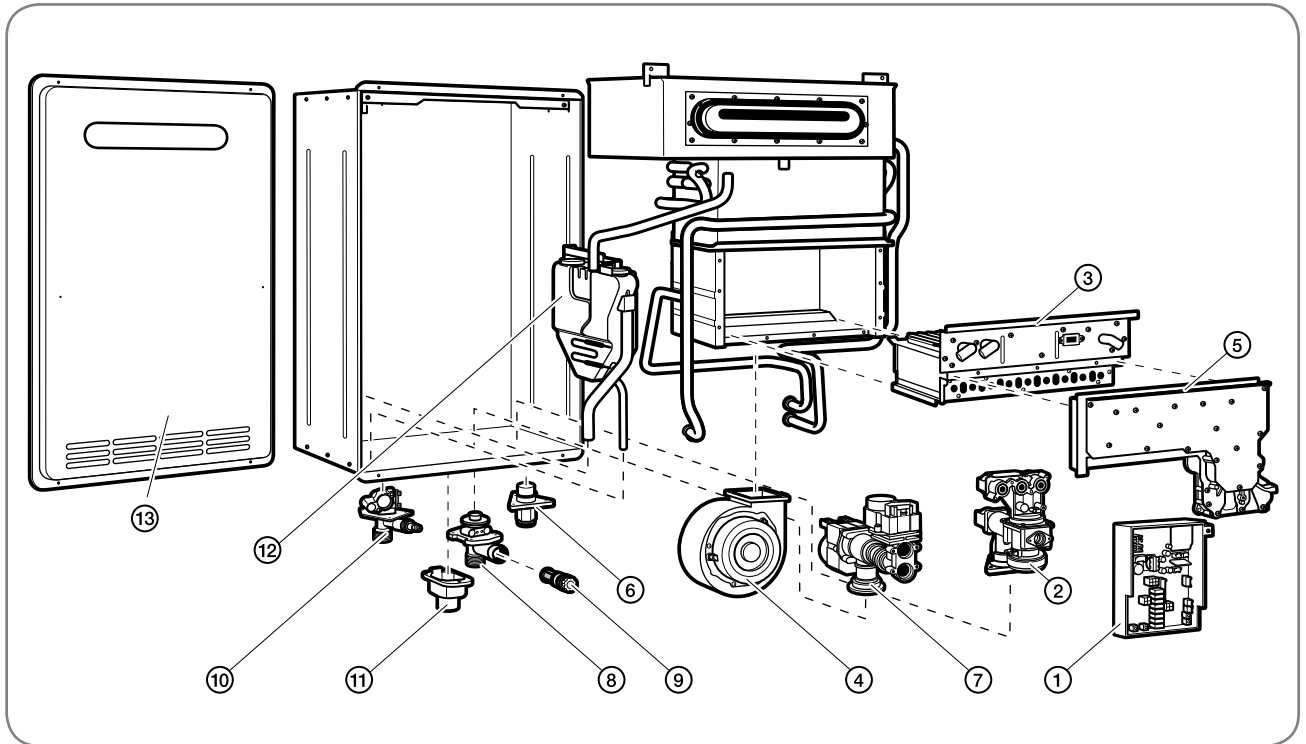

Ref #	Description
1	Control Board
2	Gas Valve
3	Burner Assembly
4	Blower Motor
5	Burner Manifold
6	Gas Inlet Connector
7	Water Control Body
8	Water Inlet Connector 3/4"
9	Drain Relief Valve
10	Hot Outlet Connector
11	Remote Control Terminal Block
12	Neutralization kit
13	Front Cover

A large, vertically oriented rounded rectangular box with a thin black border. Inside the box, there are 25 horizontal black lines spaced evenly, providing a template for writing notes.

NOTES

A large, empty rectangular box with rounded corners, designed for taking notes. It contains 25 horizontal lines spaced evenly down the page, providing a structured area for writing.