

⚠️WARNING:

If the information in these instructions is not followed exactly, a fire or explosion may result, causing death, personal injury, or property damage.

⚠️For Your Safety!

- Do not store or use gasoline or other flammable vapors and liquids in the vicinity of this or any other appliance. To do so may result in an explosion or fire.
- Installation and service must be performed by a qualified installer, service agency, or the gas supplier.

What to Do If You Smell Gas

- Do not try to light any appliance.
- Do not touch any electrical switch; do not use any phone in your building.
- Immediately call your gas supplier from a neighbor's phone. Follow the gas supplier's instructions.
- If you cannot reach your gas supplier, call the fire department.
- Do not return to your home until authorized by the gas supplier or fire department.

Do not destroy manual. Please read carefully and keep in a safe place for future reference.

Direct Vent Models

Rheem/EcoSense
RTGH-95DV*
RTGH-84V*
ECO200DV*
ECO160DV*

Paloma/Wai Wela
PHH-32RDV*
PHH-25RDV*

Ruud
RUTGH-95DV*
RUTGH-84DV*

Richmond
RMTGH95DV*
RMTGH84DV*

Outdoor Models

Rheem/EcoSense
RTGH-95X*
RTGH-84X*
ECO200X*
ECO160X*

Paloma/Wai Wela
PHH-32ROF*
PHH-25ROF*

Ruud
RUTGH-95X*
RUTGH-84X*

Richmond
RMTGH95X*
RMTGH84X*

*All models available for natural gas (N) or propane gas (P) usage.

AP15896-1(11/10)

Printed in USA

94% CONDENSING TANKLESS WATER HEATER

USE AND CARE MANUAL

With Installation Instructions
for the Installer

Water Heaters for Other Than
Recreational Vehicle Installation Only

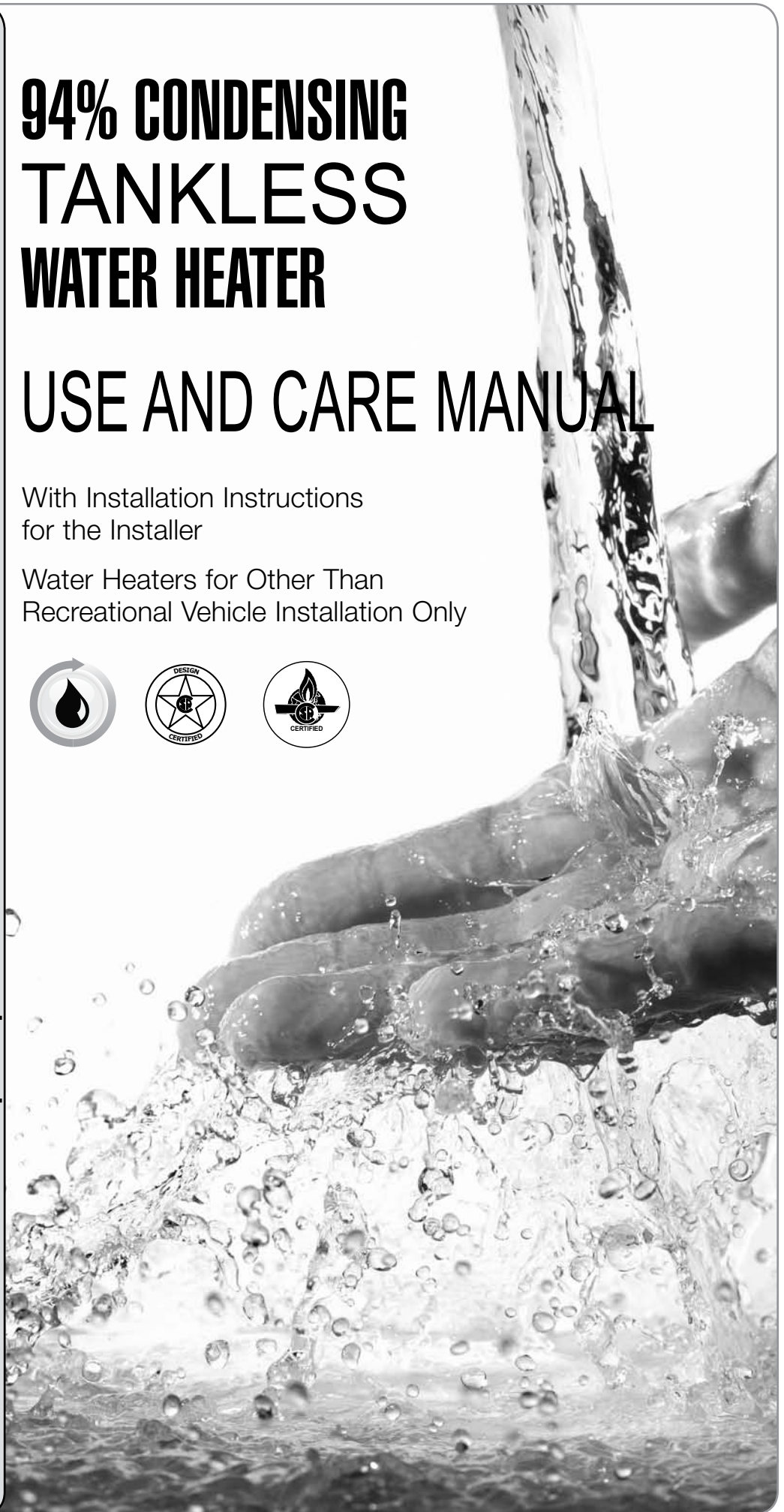

CONTENTS

Important Safety Information

Safety Precautions 2–8

Product Information

Product Information 8

Specifications 9, 10

General Descriptions 11, 12

Using Your Water Heater

Setting the Water Temperature 13, 14

Caring for Your Water Heater

Water Heater Inspections 15, 16

Care and Cleaning 17, 18

Preventive Maintenance 19

Draining the Water Heater 20–22

Freeze Protection 22

Vacation and Extended Shutdown 23

Troubleshooting Chart 23, 24

Service Error Code Chart 25, 26

If You Need Service

Call for Assistance 26

Installation Instructions

Standards Compliance 28

Choosing a Location 28, 29

Product Inspection 30

Water Heater Installation 30–33

Venting 34–46

Water Supply 47–51

Condensate 51

Gas Supply 52–56

Electrical Wiring 56–60

Remote Control Installation 59, 60

Insulation Blankets 61

Installation Checklist 62

Lighting the Water Heater 63, 64

Setting the Water Temperature 65–68

High-Altitude Adjustments 67, 68

Parts Replacement 69, 70

IMPORTANT SAFETY INFORMATION

READ THE SAFETY INFORMATION

Your safety and the safety of others are very important. There are many important safety messages in this manual and on your appliance. Always read and obey all safety messages.



This is the safety alert symbol. Recognize this symbol as an indication of Important Safety Information! This symbol alerts you to potential hazards that can kill or hurt you and others.

All safety messages will follow the safety alert symbol and either the word “DANGER,” “WARNING,” “CAUTION,” or “NOTICE.”

These words mean:

⚠DANGER: An imminently hazardous situation that will result in death or serious injury.

⚠WARNING: A potentially hazardous situation that can result in death or serious injury and/or damage to property.

⚠CAUTION: A potentially hazardous situation that may result in minor or moderate injury.

NOTICE: Attention is called to observe a specified procedure or maintain a specific condition.

⚠WARNINGS:

- This water heater is not suitable for use in manufactured (mobile) homes!
- Improper installation, adjustment, alteration, service, or maintenance can cause death, personal injury, or property damage. Refer to this manual.

READ ALL INSTRUCTIONS BEFORE USING.

Be sure to read and understand the entire Use and Care Manual before attempting to install or operate this water heater. It may save you time and money. Pay particular attention to the Safety Instructions. Failure to follow these warnings could result in death or serious bodily injury. Should you have problems understanding the instructions in this manual, or have any questions, STOP and get help from a qualified service technician or the local gas utility.

⚠WARNING:

California Proposition 65

This product contains chemicals known to the state of California to cause cancer, birth defects, or other reproductive harm.

IMPORTANT SAFETY INFORMATION

Water Heater Venting Safety

⚠ DANGER: Failure to install and properly vent the water heater to the outdoors as outlined in the “Venting” section of the Installation Instructions in this manual will result in death from fire, explosion, or asphyxiation from carbon monoxide. NEVER operate this water heater unless it is properly vented and has an adequate air supply for proper operation.

Be sure to inspect the vent terminal, the air intake, and the vent system on the water heater for proper installation at initial start-up and at least annually thereafter. Refer to the “Care and Cleaning” section of this manual for more information regarding vent system inspection.

⚠ WARNINGS:

- Gasoline and other flammable liquids, materials, and vapors (including paint thinners, solvents, and adhesives) are extremely dangerous. DO NOT handle, use, or store gasoline or other flammable or combustible materials anywhere in the vicinity of a water heater or any other appliance. Be sure to read and follow the labels on the water heater, as well as the warnings printed in this manual. Failure to do so can result in death, bodily injury, or property damage.
- Combustible construction refers to adjacent walls and ceilings and should not be confused with combustible or flammable products and materials. Combustible materials, such as clothing, cleaning materials, or flammable liquids, should never be stored in the vicinity of this or any gas appliance. Fire or explosion can occur causing death, personal injury, and/or product damage. See page 29 for clearances to combustible materials.
- Follow vent manufacturer’s instructions for venting installation, including additional clearances from combustibles, to avoid conditions that can lead to death, personal injury, and/or property damage.
- Use tankless water heater manufacturer-approved Schedule 40 PVC (foam core is not permitted at any time), Schedule 80 PVC, CPVC, ABS, polypropylene, or UL 1738-listed Category III Stainless Steel. No other vent material is permitted.
- Moisture in the flue gas will condense as it leaves the vent terminal. In cold weather this condensate can freeze on the exterior wall, under the eaves, and on surrounding objects. Some discoloration to the exterior of the building is to be expected. However, improper location or installation can result in severe damage to the structure or exterior finish of the building.

⚠ DANGER

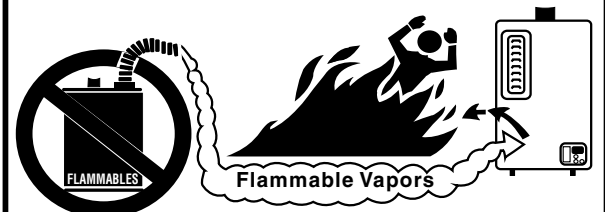

⚠ Vapors from flammable liquids will explode and catch fire causing death or severe burns.
Do not use or store flammable products such as gasoline, solvents or adhesives in the same room or area near the water heater.
Keep flammable products:
1. far away from heater,
2. in approved containers,
3. tightly closed and
4. out of children's reach.

Water heater has a main burner flame.
The main burner flame:
1. which can come on at any time and
2. will ignite flammable vapors.
Vapors:
1. cannot be seen,
2. are heavier than air,
3. go a long way on the floor and
4. can be carried from other rooms to the main burner flame by air currents.

Installation:
Do not install water heater where flammable products will be stored or used unless the main burner flame is at least 18" above the floor. This will reduce, but not eliminate, the risk of vapors being ignited by the main burner flame.

Read and follow water heater warnings and instructions. If owners manual is missing, contact the retailer or manufacturer.

- For multiple-unit installation, a minimum distance between vent terminations must be maintained to prevent recirculation of vent gases. See page 39 for information on venting and clearances to multiple terminations.

⚠ CAUTIONS:

- Ensure that the appliance vent is securely glued and attached to the vent connection on the top of the water heater. DO NOT USE SCREWS.
- Do not operate without the condensate drain connected and routed to the proper drain.

IMPORTANT SAFETY INFORMATION

Water Supply Safety

⚠️ DANGERS:

- **WATER TEMPERATURE SETTINGS** – Safety and energy conservation are factors to be considered when selecting the water temperature setting of a water heater's remote control. Water temperatures above 125°F (52°C) can cause death or severe burns from scalding. Be sure to read and follow the warnings outlined on the pictured label.
- There is a hot water scald potential if the water temperature is set too high. Households with small children, the disabled, or elderly persons may require a 120°F (49°C) or lower temperature setting to prevent contact with "HOT" water.
- Before manually operating the relief valve, make certain no one will be exposed to the danger of the hot water released by the valve. The water may be hot enough to create a scald hazard. The water should be released into a suitable drain to prevent injury or property damage.
- Failure to perform the recommended Routine Preventive Maintenance can harm the proper operation of this water heater, which can cause carbon monoxide dangers, excessive hot water temperatures, and other potentially hazardous conditions.

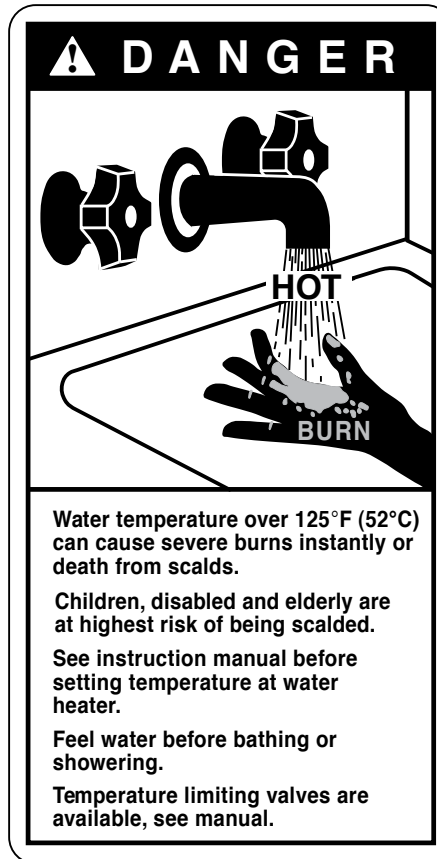

⚠️ WARNINGS:

- **IMPORTANT:** Do not apply heat to the HOT or COLD water connections. If sweat connections are used, sweat tubing to adapter before fitting adapter to the water connections on heater. Any heat applied to the water supply fittings will permanently damage the internal components of the water heater.
- In case the pipe insulation is not rated for the appropriate weather conditions, install electric heat tracing or equivalent to prevent freezing of the pipes. Do not insulate or block the drain valve on the hot outlet fitting. If the pipes are allowed to freeze, the water heater and the pipes may malfunction or leak due to freezing water.
- Failure to drain the water heater as described on page 20 can cause serious personal injuries from scalding and/or damage the water heater.

⚠️ CAUTIONS:

- This water heater must only be used with the following water supply system conditions:
 - With clean, potable water free of corrosive chemicals, sand, dirt, or other contaminants.
 - With inlet water temperatures above 32°F (0°C), but not exceeding 120°F (49°C).
 - DO NOT reverse the hot and cold water connections. The water heater will not operate.
- Even when drained properly, a small amount of water will remain in the water heater. In cold weather conditions, this water can freeze. If this happens, allow the defrost protection on the heater at least 30 minutes to melt the frozen water or the water heater may not work properly.

NOTICE: The factory setting allows operating temperatures between 100°F (38°C) and 120°F (49°C). Temperatures of 85°F (29°C) and up to 140°F (60°C) can be achieved with the MAIN (UMC-117) remote control. Temperatures of 85°F (29°C) can be achieved with the Bath (USC-117 or USC2-117) remote control. Only qualified service personnel should perform this adjustment. Only factory-authorized remote control(s) should be used.

Time/Temperature Relationship in Scalds

Water Temperature	Time to Produce a Serious Burn
120°F (49°C)	More than 5 minutes
125°F (52°C)	1 1/2 to 2 minutes
130°F (54°C)	About 30 seconds
135°F (57°C)	About 10 seconds
140°F (60°C)	Less than 5 seconds
145°F (63°C)	Less than 3 seconds
150°F (66°C)	About 1 1/2 seconds
155°F (68°C)	About 1 second

Table courtesy of Shriners Burn Institute

Temperature Conversion Chart °F/°C

85	100	102	104	106	108	110	112	114	116	118	120	125	130	140	°F
29	38	39	40	41	42	43	44	46	47	48	49	52	54	60	°C

Natural Gas and Liquefied Petroleum Safety

⚠ DANGERS:

- Never attempt to convert the water heater from natural gas to LP. The water heater should only use the fuel type in accordance with listing on data plate—natural gas for natural gas units and LP for LP units. Any other fuel usage will result in death or serious personal injury from fire and/or explosion. This water heater is not certified for any other fuel type.
- Both natural gas and propane (LP) have an odorant added to aid in detecting a gas leak. Some people may not physically be able to smell or recognize this odorant. If you are unsure or unfamiliar with the smell of natural gas or LP, ask the gas supplier. Other conditions, such as “odorant fade,” which causes the odorant to diminish in intensity, can also hide or camouflage a gas leak.
- Water heaters using LP gas are different from natural gas models. A natural gas water heater will not function safely on LP and vice versa.
- LP water heaters should not be installed below grade (for example, in a basement) if such installation is prohibited by federal, state, and/or local laws, rules, regulations, or customs.
- LP must be used with great caution. It is heavier than air and will collect first in lower areas, making it hard to detect at nose level.
- Before attempting to light the water heater, make sure to look and smell for gas leaks. Use a soapy solution to check all gas fittings and connections. Bubbling at a connection indicates a leak that must be corrected. When smelling to detect a gas leak, be sure to also sniff near the floor.
- Gas detectors are recommended in LP and natural gas applications and their installation should be in accordance with the detector manufacturer’s recommendations and/or local laws, rules, regulations, or customs.
- Combustible materials, such as clothing, cleaning materials, or flammable liquids, must not be placed in the vicinity of the water heater.
- **If a gas leak is present or suspected:**
 - Do not attempt to find the cause yourself.
 - Never use an open flame to test for gas leaks. The gas can ignite resulting in death, personal injury, or property damage.
 - Follow the steps listed under “*What to Do If You Smell Gas*” found on the front cover of this manual.

⚠ WARNINGS:

- The installation of gas piping must conform to local utility company requirements and/or in the absence of local codes, use the latest edition of National Fuel Gas Code (NFGC), ANSI Z223.1/NFPA 54, or CSA B149.1, Natural Gas and Propane Installation Code.
- Install a gas pressure regulator in the gas supply line. The regulator should not exceed the maximum supply pressure. **DO NOT** use an industrial-type gas regulator.
- Should overheating occur or the gas supply fail to shut off, turn off the manual gas control valve to the water heater.

⚠ CAUTIONS:

- Do not attempt repair of electrical wiring, gas piping, remote control, burners, vent connectors, or other safety devices. Refer repairs to qualified service personnel.
- Turn off the manual gas shut-off valve if the water heater has been subjected to overheating, fire, flood, physical damage, or if the gas supply fails to shut off.
- Do not turn on the water heater unless the water and gas supplies are completely opened.

IMPORTANT SAFETY INFORMATION

Before operating this water heater, be sure to read and follow the instructions on the label pictured below and all other labels on the water heater, as well as the warnings printed in this manual. Failure to do so can result in unsafe operation of the water heater, resulting in death, personal injury, or property damage. Should you have any problems reading or following the instructions in this manual, **STOP** and get help from a qualified service technician.

FOR YOUR SAFETY READ BEFORE OPERATING

WARNING : If you do not follow these instructions exactly, a fire or explosion may result causing property damage, personal injury or loss of life.

A. This appliance does not have a pilot. It is equipped with an ignition device which automatically lights the burner. Do not try to light the burner by hand.

B. **BEFORE OPERATING** smell all around the appliance area for gas. Be sure to smell next to the floor because some gas is heavier than air and will settle on the floor.



WHAT TO DO IF YOU SMELL GAS

- Do not try to light any appliance.
- Do not touch any electric switch; do not use any phone in your building.
- Immediately call your gas supplier from a neighbor's phone. Follow the gas supplier's instructions.
- If you cannot reach your gas supplier, call the fire department.
- Do not return to your home until authorized by the gas supplier or fire department.

C. Use only your hand to push in or turn the gas control knob. Never use tools. If the knob will not push in or turn by hand, don't try to repair it, call a qualified service technician. Force or attempted repair may result in a fire or explosion.

D. Do not use this appliance if any part has been under water. Immediately call a qualified service technician to inspect the appliance and to replace any part of the control system and any gas control which has been under water.

OPERATING INSTRUCTIONS

1. **STOP!** Read the safety information above on this label.
2. Turn off all electric power to the appliance.
3. Do not attempt to light the burner by hand.
4. Turn the Gas Shutoff Valve located on the outside of the unit clockwise  to the "OFF" position.
5. Wait five (5) minutes to clear out any gas. If you then smell gas, **STOP!** Follow "B" in the safety information above on this label. If you don't smell gas, go to the next step.
6. Turn the Gas Shutoff Valve located on the outside of the unit counterclockwise  to the "ON" position.
7. Turn on all electric power to the appliance.
8. If the appliance will not operate, follow the instructions "To Turn Off Gas To Appliance" and call your service technician or gas supplier.

GAS SHUTOFF VALVE



OPEN



CLOSE

TO TURN OFF GAS TO APPLIANCE

1. Turn off all electric power to the appliance if service is to be performed.
2. Turn the Gas Shutoff Valve located on the outside of the unit clockwise  to the "OFF" position.

IMPORTANT SAFETY INFORMATION

Electrical Safety

⚠ DANGER: **Shock Hazard** – Make sure the electrical power to the water heater is off to avoid electric shock that will result in death or serious personal injury.

⚠ WARNINGS:

- For your safety, the information in this manual must be followed to minimize the risk of fire, explosion, or electric shock that can result in death, personal injury, and/or property damage.
- Field wiring connections and electrical grounding must comply with local codes or, in the absence of local codes, with the latest edition of the National Electrical Code, ANSI/NFPA 70, or in Canada, Canadian Electrical Code, CSA C22.1, Part 1.

⚠ CAUTIONS:

- Label all wires prior to disconnecting for service. Wiring errors can cause dangerous and improper operation. Verify correct operation after servicing.
- For your safety, burner inspection and cleaning should be performed only by qualified service personnel.
- Make certain the power to the water heater is OFF before removing the unit cover panel. Exposed electrical components and moving parts can cause personal injuries.
- For your safety, DO NOT attempt repair of electrical wiring, gas piping, remote control, burners, vent connectors, or other safety devices. Refer repairs to qualified service personnel.

FOR INSTALLATIONS IN THE STATE OF CALIFORNIA

California law requires that water heaters must be braced, anchored, or strapped to resist falling or horizontal displacement due to earthquake motions. For water heaters up to 52-gallon capacity, a brochure with generic earthquake bracing instructions can be obtained from: Office of the State Architect, 1102 Q Street, Suite 5100, Sacramento, CA 95814, or you may call 916-445-8100 or ask a water heater dealer.

However, applicable local codes shall govern installation. For residential water heaters of a capacity greater than 52 gallons or tankless-style, consult the local building jurisdiction code for acceptable bracing procedures.

IMPORTANT SAFETY INFORMATION

General Installation and Maintenance Safety

⚠️ WARNINGS:

- This water heater must be installed in accordance with these instructions, local codes, utility company requirements and/or in the absence of local codes, use the latest edition of the American National Standard/National Fuel Gas Code (NFGC), ANSI Z223.1 and National Fire Protection Association, NFPA 54, or in Canada, CSA B149.1, Natural Gas and Propane Installation Code, and the latest edition of the National Electrical Code, ANSI/NFPA 70, or in Canada, Canadian Electrical Code, CSA C22.1, Part 1.
- If local codes require the application of external insulation blanket kits, carefully follow the manufacturer's installation instructions included with the kit. Only use blanket kits that are approved for use with your water heater.
- For your safety, DO NOT attempt to disassemble this water heater for any reason. Improper adjustments, alterations, service, or maintenance can cause death, personal injury, or property damage.

SAFETY PRECAUTIONS:

- Read this manual entirely before installing and/or operating the water heater.
- Use this water heater only for its intended purpose as described in this Use and Care Manual.
- Have the installer show you the location of the gas shut-off valve and how to shut it off if necessary. Turn off the manual shut-off valve if the water heater has been subjected to overheating, fire, flood, physical damage, or if the gas supply fails to shut off.
- Be sure your water heater is properly installed in accordance with local codes and the provided installation instructions.
- Do not attempt to repair or replace any part of your water heater unless it is specifically recommended in this manual. All other servicing should be referred to a qualified service technician.

SAVE THESE INSTRUCTIONS

PRODUCT INFORMATION

For Your Records

Write down and save the following product information along with the original sales slip and/or cancelled check. The model and serial numbers can be found on the top label on the right side of the water heater.

MODEL NUMBER: _____

SERIAL NUMBER: _____

DATE OF INSTALLATION: _____

INSTALLING COMPANY/PHONE NUMBER:

PLUMBING CONTRACTOR/PHONE NUMBER:

See page 26 for additional service information.

Read This Manual

Inside you will find many helpful hints on how to use and maintain your water heater properly. A little preventive care on your part can save you time and money over the life of your water heater.

You'll find many answers to common problems in the Troubleshooting Chart on pages 23 and 24. Always refer to this chart before calling for service. Referring to this chart before calling may answer your question(s) and eliminate the need for service.

Preoperating Checklist

- Is the main gas valve to the water heater turned on?
- Does the water heater have its own circuit breaker or fuse?
- Does the water heater's electronic ignition light?
- Is the water temperature set to a safe temperature?
- Is the water heater connected to a floor drain?
- Is the water heater properly vented to the outside?
- Is the water heater installed in a safe location away from flammable materials and/or freezing conditions?

Specifications – Direct-Vent Models

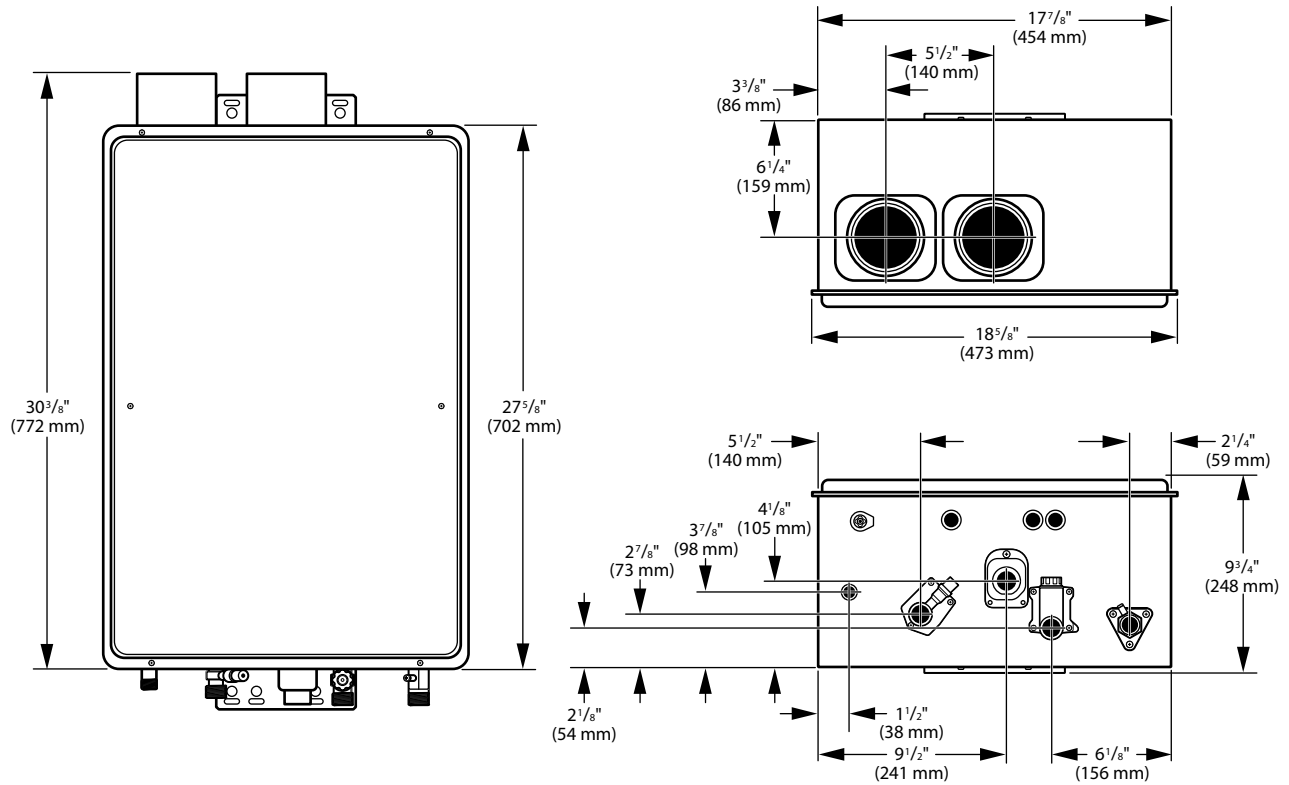

Specifications – Outdoor Models

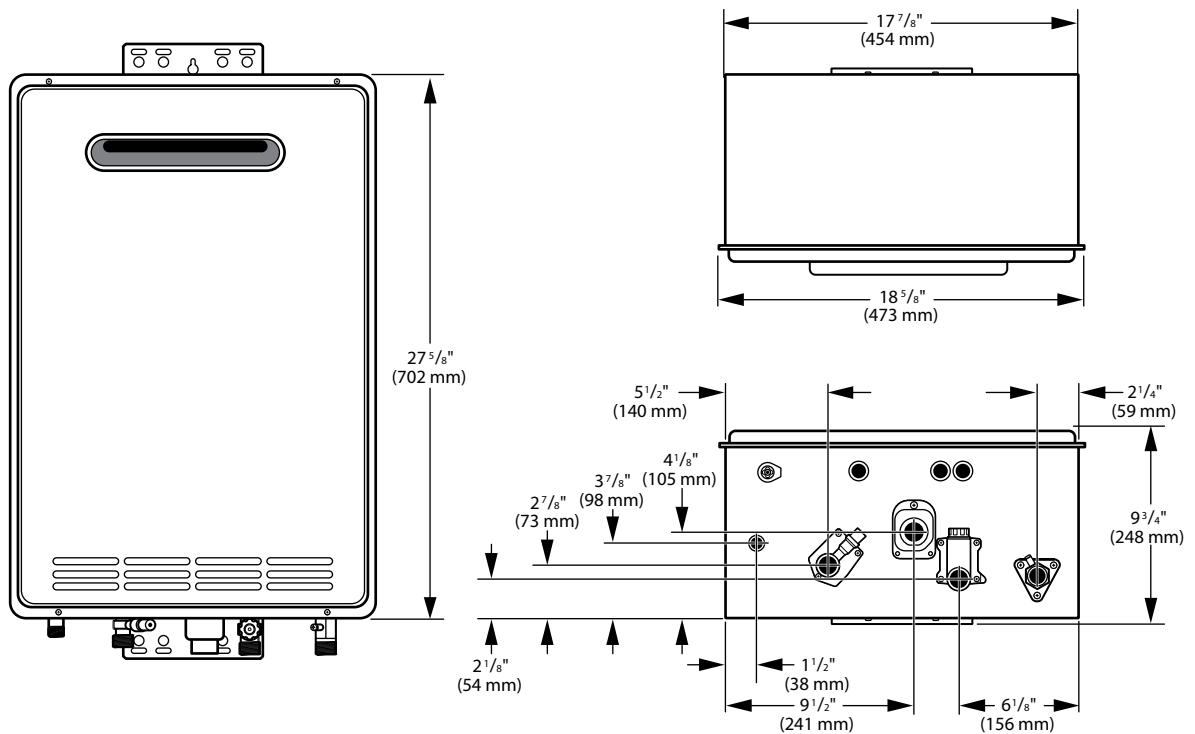

PRODUCT INFORMATION

Specifications

MANUFACTURER	157k BTU MODELS		199.9k BTU MODELS	
Rheem EcoSense Paloma/Wai Wela Ruud Richmond	RTGH-84DV* and RTGH-84X* ECOH160DV* and ECOH160X* PHH-25RDV* and PHH-25ROF* RUTGH-84DV* and RUTGH-84X* RMTGH84DV* and RMTGH84X*		RTGH-95DV* and RTGH-95X* ECOH200DV* and ECOH200X* PHH-32RDV* and PHH-32ROF* RUTGH-95DV* and RUTGH-95X* RMTGH95DV* and RMTGH95X*	
Appliance Type	Indoor (DV) & Outdoor (X)		Indoor (DV) & Outdoor (X)	
Electrical Rating	120V/60Hz		120V/60Hz	
Type of Gas*	NG	LP	NG	LP
Inlet Gas Pressure Max. (in. of w.c.)	10.5	13.0	10.5	13.0
Inlet Gas Pressure Min. (in. of w.c.)	4.0	8.0	4.0	8.0
Manifold Pressure (in. of w.c. at max. input)	2.5 Indoor 2.6 Outdoor	3.1	3.9 Indoor 4.2 Outdoor	4.6 Indoor 4.7 Outdoor
Maximum Water Supply Pressure (psi)	150		150	
Maximum Input Rate (btu/hr)	157,000		199,900	
Minimum Input Rate (btu/hr)	11,000		11,000	
Recover Rating (gal/hr)	178		226	
Shipping Weight (lbs)	81		81	
Minimum Activation Flow Rate (gpm)	0.40		0.40	
Extinction Flow Rate (gpm)	0.25		0.25	
Hot Water Capacity (gpm @ 35°F rise)	8.5		9.5	
Hot Water Capacity (77°F rise)	3.9		4.9	
Default Temperature Setting (no controller)	120		120	
Temperature Default Setting	100		100	
Minimum Temperature Setting (°F)	85		85	
Efficiency Rating (Energy Factor)	0.94		0.94	
Electrical Consumption				
Normal	100 W		100 W	
Standby	3-5 W		3-5 W	
Antifreeze Protection	200 W		200 W	
Vent Size (Indoor Only)	2" or 3"		2" or 3"	
Water Connections	3/4" NPT		3/4" NPT	
Gas Connection	3/4" NPT		3/4" NPT	
Water Supply Pressure	14-150 PSI		14-150 PSI	
High Altitude (up to 10,000 ft.)	Yes		Yes	
Multiple-Unit Installation	Yes		Yes	
Safety Devices	Overheat Film Wrap, Flame Rod, Water Temperature High-Limit Switch, Flue Temperature High-Limit Switch			
Accessories	Remote Control, Service Valves, Vent Kits, Pipe Cover, EZ Link, MIC-6, MIC-185, Recess Box**			

*N or NG = natural gas and P or LP = liquefied petroleum
** = Outdoor Only

General Descriptions

Typical Direct-Vent Water Heater (Venting Required)

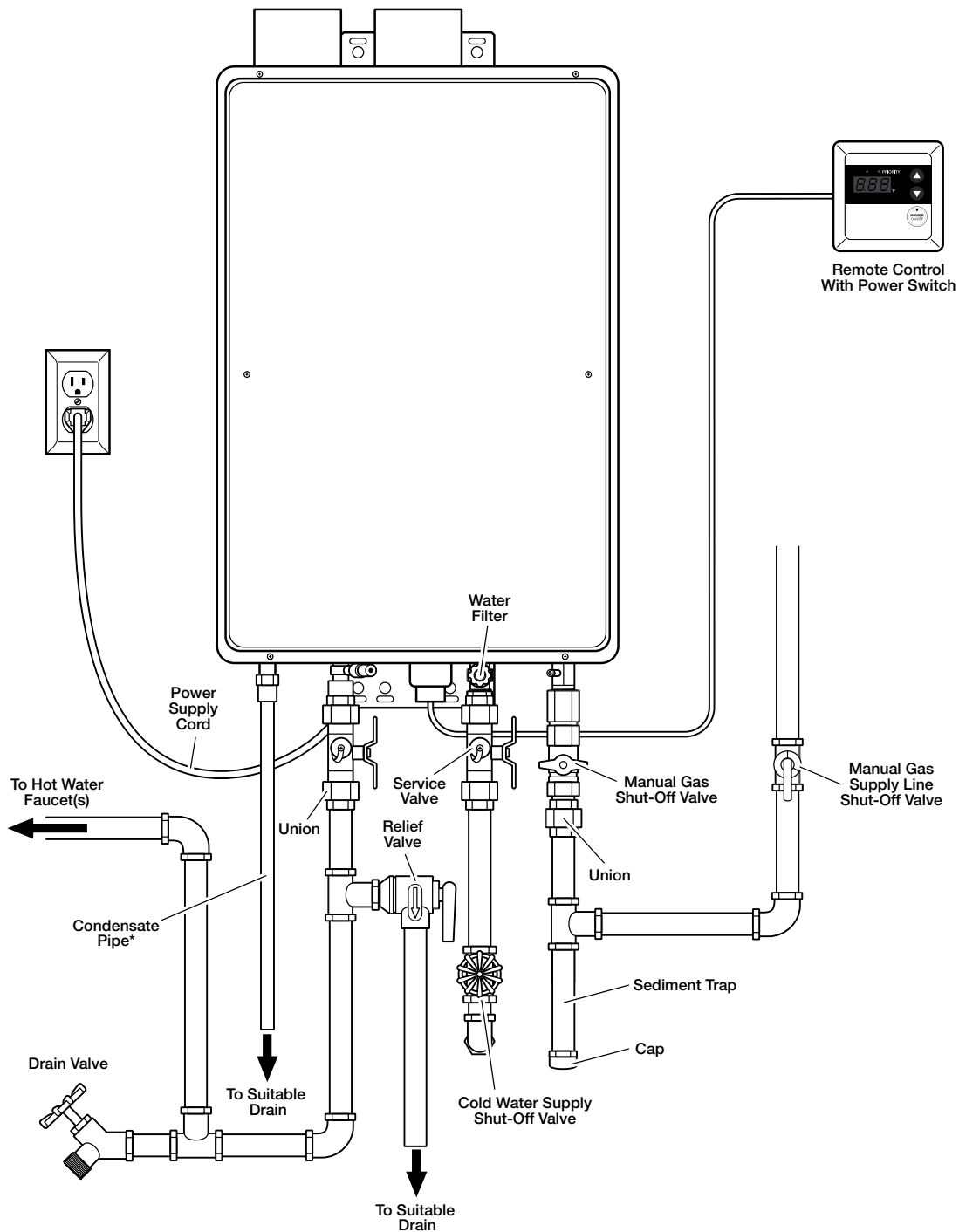

*Note: A flexible drain tube can be used

Product Information

PRODUCT INFORMATION

Typical Outdoor Water Heater (No Venting Required)

This water heater is for **OUTDOOR** installation only.

⚠ DANGER: DO NOT install this water heater indoors or in an enclosure. It is designed for outdoor installation only. Any other type of installation will result in death or serious personal injury.

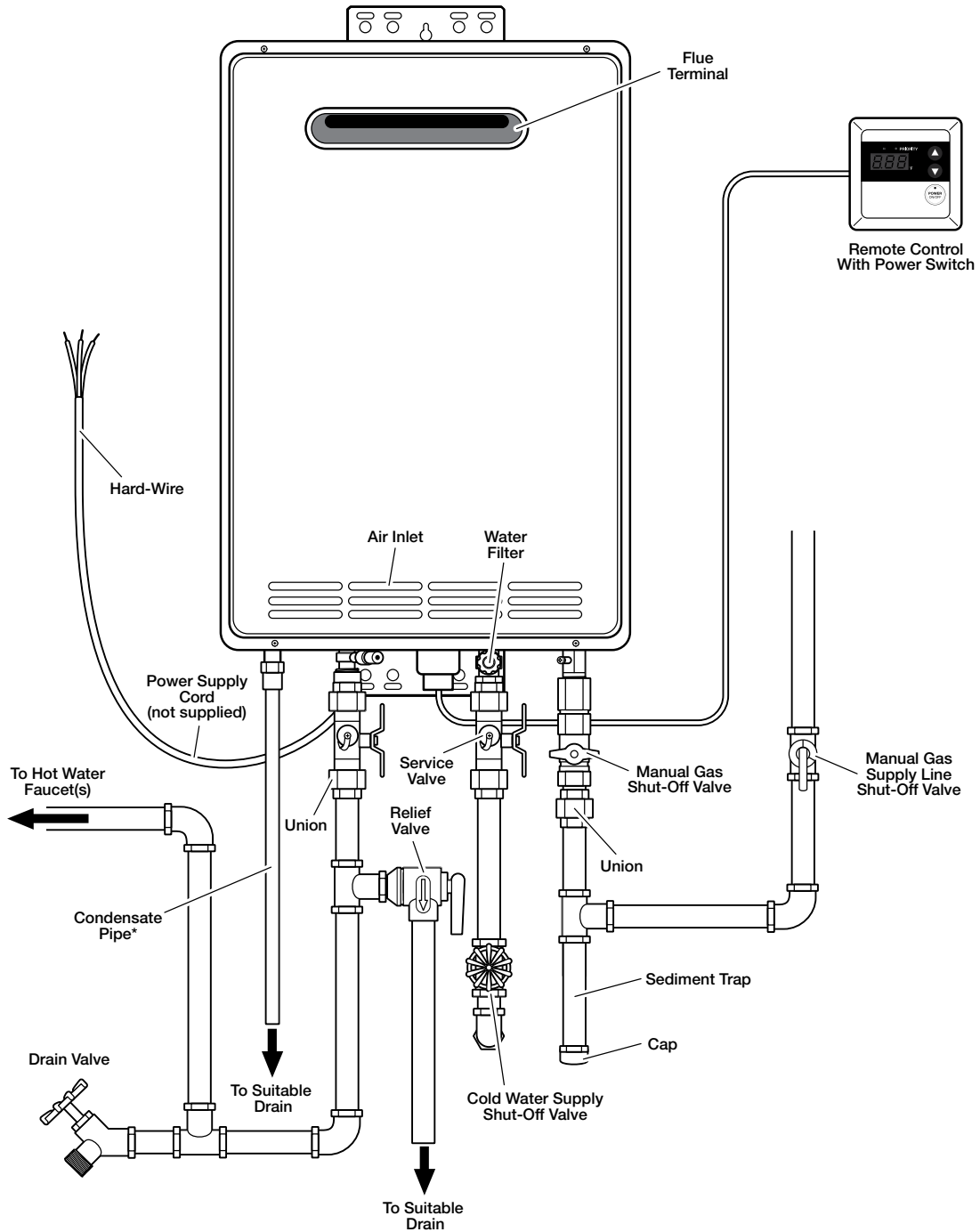

*Note: A flexible drain tube can be used

USING YOUR WATER HEATER

Safety Precautions

⚠️WARNING: Flammable vapors can be drawn by air currents from surrounding areas to the water heater. Vapors can ignite causing death, personal injury, or product damage.

- DO NOT store or use flammable or combustible materials (gasoline, paint thinner, adhesives, newspapers, rags, mops, etc.) in the vicinity of the water heater or any other gas appliance. If they must be used, open doors and windows for ventilation, and shut off all gas-burning appliances, including their pilot lights.

- DO turn off manual gas shut-off valve if water heater has been subjected to overheating, fire, flood, physical damage, or if the gas supply fails to shut off.
- DO NOT turn on water heater unless water and gas supplies are completely opened.
- DO NOT turn on water heater if cold water supply shut-off valve is closed.
- If there is any difficulty in understanding or following the operating and care instructions in this manual, it is recommended that you contact a qualified service technician to perform the work.

Setting the Water Temperature

⚠️DANGER: Water temperatures above 125°F (52°C) will result in death and/or severe burns from scalding.

Safety and energy conservation are factors to be considered when selecting the water temperature setting. The temperature of the water in the water heater can be regulated by setting the temperature on the front of the remote control. Be sure to read and follow the warnings outlined on the pictured label.

The recommended setting for the water temperature is 100°F (38°C). The remote control has been preset and shipped at the recommended temperature setting.

Safety factors should be considered whenever altering the water temperature setting. The chart below may be used as a guide in determining the proper water temperature for your home.

Time/Temperature Relationship in Scalds

Water Temperature	Time to Produce a Serious Burn
120°F (49°C)	More than 5 minutes
125°F (52°C)	1 1/2 to 2 minutes
130°F (54°C)	About 30 seconds
135°F (57°C)	About 10 seconds
140°F (60°C)	Less than 5 seconds
145°F (63°C)	Less than 3 seconds
150°F (66°C)	About 1 1/2 seconds
155°F (68°C)	About 1 second

Table courtesy of Shriners Burn Institute

⚠️ DANGER



Water temperature over 125°F (52°C) can cause severe burns instantly or death from scalds.

Children, disabled and elderly are at highest risk of being scalded.

See instruction manual before setting temperature at water heater.

Feel water before bathing or showering.

Temperature limiting valves are available, see manual.

Use Instructions

USING YOUR WATER HEATER



Setting the Water Temperature (cont.)

Maximum water temperature occurs while the water heater burner is on. To determine the water temperature:

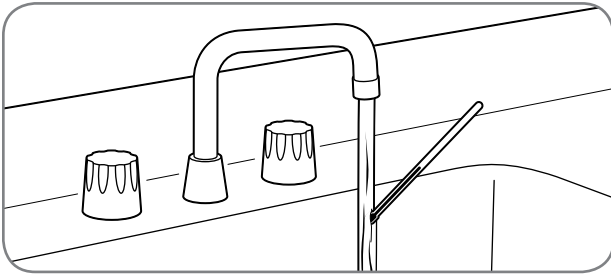

Turn on the hot water faucet and place a thermometer in the water stream.

NOTICE: Water temperature at the faucet may vary depending on the season and the length of pipe from the water heater.

The remote control temperature range is between 100°F (38°C) and 120°F (49°C). To adjust the temperature to a desired setting, press the UP or DOWN adjustment button on the face of the remote control. The new temperature set point will show on the LED display.

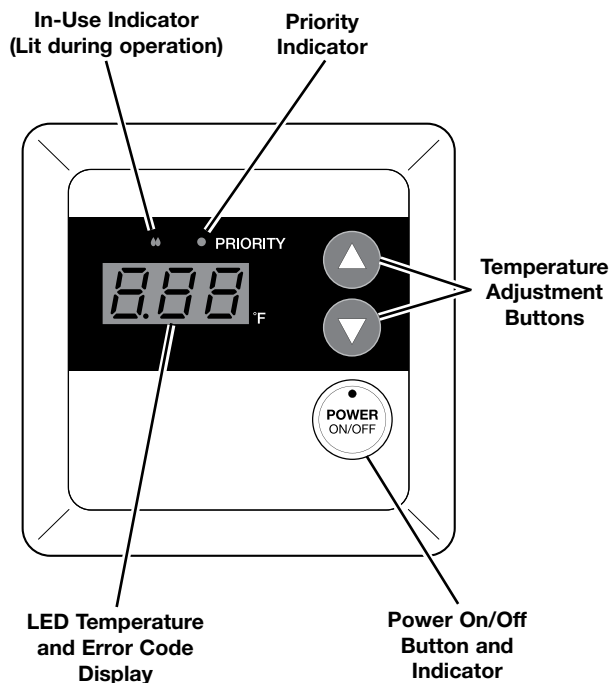

NOTICES:

- The temperature set point on the standard remote control cannot be increased above 112°F (44°C) when a hot water faucet is in the open position. To achieve temperatures above 120°F (49°C) or 85°F (29°C), contact a qualified service technician. Only factory-authorized remote control(s) should be used.
- The water heater may not operate with a small water flow. Increase the water flow and recheck. If it still does not operate with the hot water faucet completely open, increase the temperature setting on the remote control.

Water Heater Facts

⚠ DANGER: Water temperatures above 125°F (52°C) will result in death and/or severe burns from scalding.

- The hottest-temperature water will be at the faucet closest to the water heater.
- Always remember to test the water temperature with your hand before use.
- Always supervise young children or others who are incapacitated.
- The water heater is equipped with a device that will shut off the gas supply to the burner if the water heater exceeds normal operating temperatures.
- Any water heater that has been subjected to fire, flood, physical damage, or been under water should be turned off at the manual gas shut-off valve and not used until it has been checked by qualified service personnel.



Water Heater Inspections

Venting System

(Direct Vent Only)

The venting system should be inspected annually to ensure all of the vent sections are secure and airtight. Qualified service personnel are familiar with vent system inspections.

⚠WARNING: Do not operate the water heater if the vent system shows signs of leaking exhaust. Leaking exhaust could lead to death, personal injury, and/or product failure.

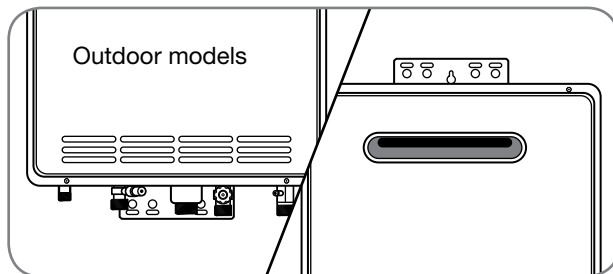

For outdoor models, check the air intake and vent outlet for blockage and/or debris.

Condensate Collector

⚠CAUTIONS:

- Condensate is known to be acidic; refer to federal, state (provincial), and local codes for proper handling and discharge methods.
- Do not operate without the condensate collector drain connected and routed to the proper drain. This could cause the system to malfunction or fail.

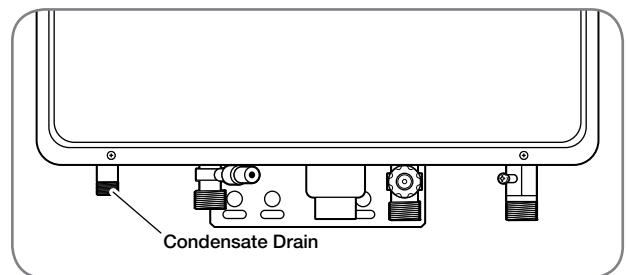
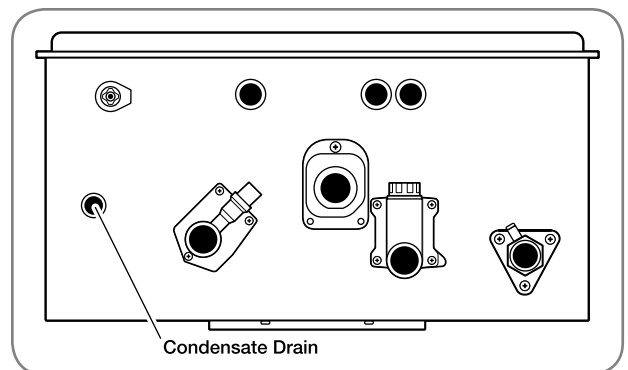

On a regular basis, inspect the condensate drain line to ensure the condensate is draining properly.

The condensate coming from the water heater is known to be acidic. The heater features a built-in condensate neutralizer that uses CaCO_3 (calcium carbonate) in rock form as a medium.

⚠DANGER: Shock Hazard – Make sure the electrical power to the water heater is off to avoid electric shock that will result in death or serious personal injury.

Periodically check the medium visually to ensure that it is not depleted and refill accordingly. It is recommended that you contact a qualified service technician to perform the work.

CARING FOR YOUR WATER HEATER



Water Heater Inspections (cont.)

Burner

Visually inspect the main burner annually.

⚠ DANGER: Shock Hazard – Removing the front cover panel exposes you to live electricity. Electric shock will cause death or serious personal injury.

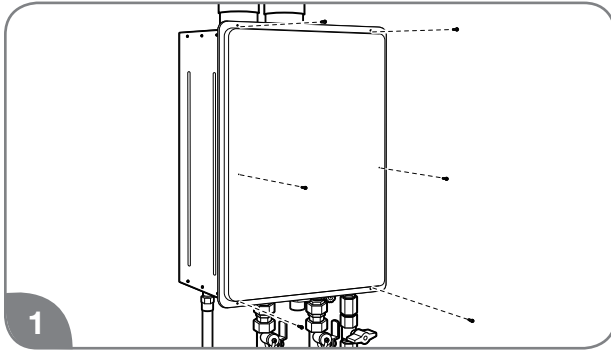

Remove 6 screws and the unit cover panel.

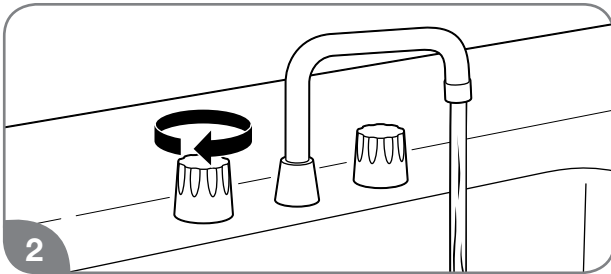

Turn on a hot water faucet.

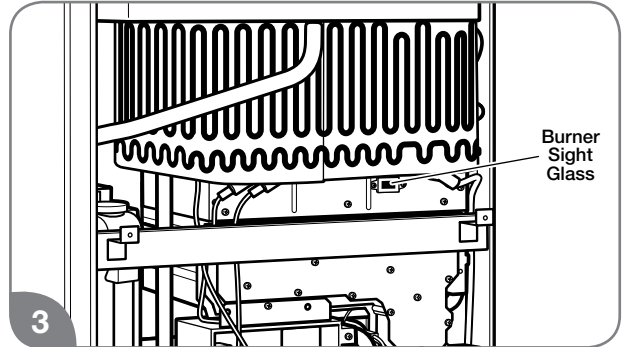

While the water heater is operating, inspect the main burner flames through the burner sight glass. The flames should be blue when the main burner is firing.

NOTICE: If the flames are not blue or you observe unusual burner operation, shut off the water heater and contact a qualified service technician.

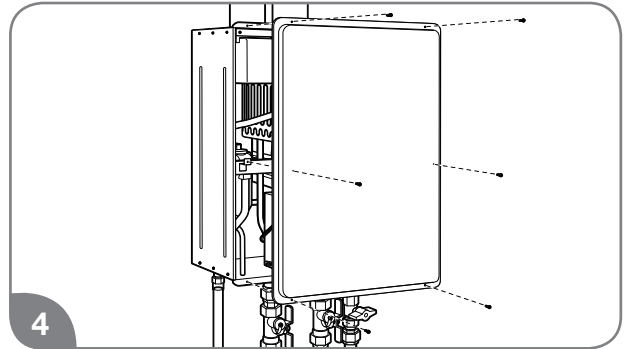

Turn off the hot water faucet and reinstall the unit cover panel.

CARING FOR YOUR WATER HEATER



Care and Cleaning

⚠ DANGER: Shock Hazard – Make certain power to the water heater is OFF before removing protective cover for any reason. Electric shock will cause death or serious personal injury.

⚠ WARNING: Combustible materials, such as clothing, cleaning materials, or flammable liquids, must not be placed against or next to the water heater. Fire or explosion can occur causing death, personal injury, and/or product damage.

All care and cleaning to and around the water heater should only be performed with the water heater turned off and the electrical power supply disconnected.

NOTICE: The air intake requires a minimum of 12 in. (30 cm) of clearance between the air intake opening and any obstruction. Clean the water filter monthly, as described below.

Water Filter Cleaning

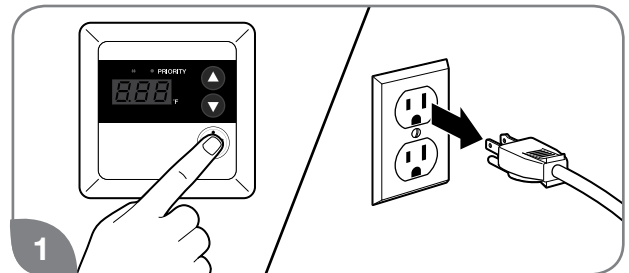

1 Turn off the water heater and disconnect the electrical power supply.

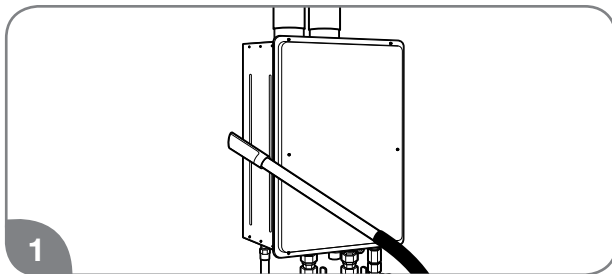

1 Vacuum around the water heater to remove any dust, dirt, and/or lint buildup.

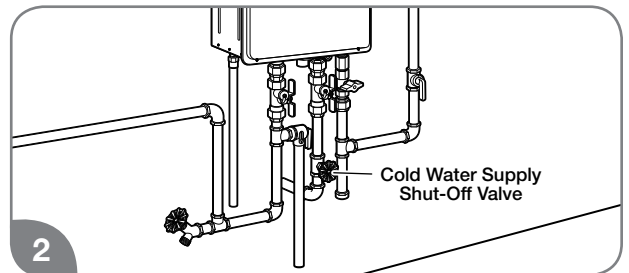

2 Turn off the water supply to the water heater.

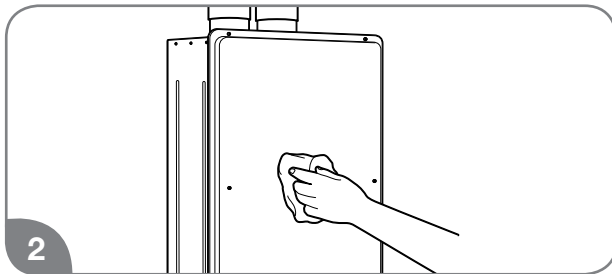

2 Clean the water heater and the remote control with a damp soft cloth and mild detergent. Gently wipe and completely dry all surfaces.

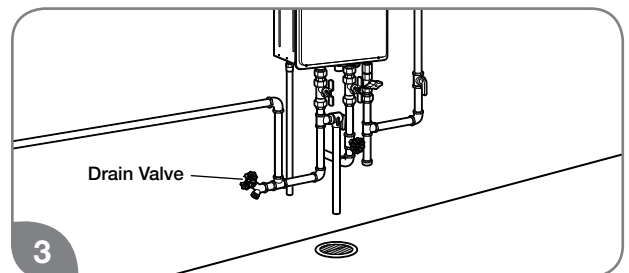

3 Drain the water heater. See page 20.

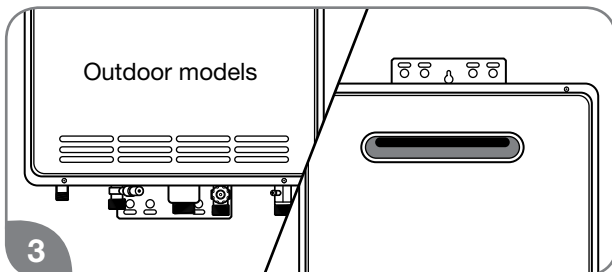

3 Check the air intake and vent outlet for blockage and/or debris.

CARING FOR YOUR WATER HEATER



Care and Cleaning (cont.)

⚠ CAUTION: Do not tap or force the filter during removal. This can deform and/or damage the filter.

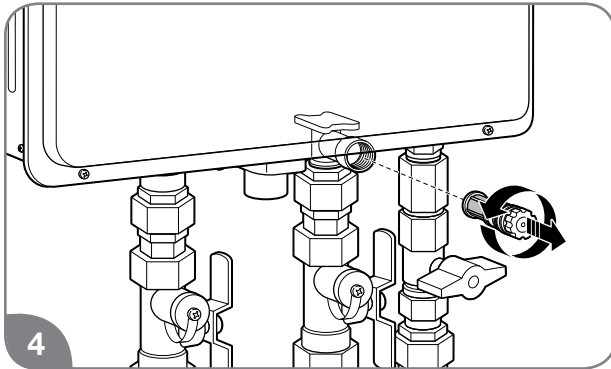

4
Unscrew the water filter from the base of the cold water inlet line and carefully slide it out of the line.

⚠ CAUTION: Do not overtighten the water filter. Overtightening can deform and/or damage the filter.

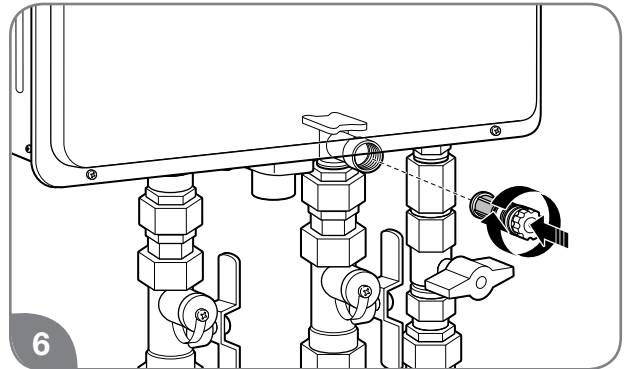

6
Replace the filter in the cold water inlet line and tighten until it is snug.

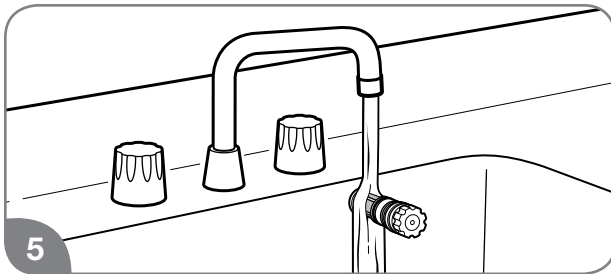

5
Clean the water filter under running water. To remove severe sediment and dirt, use a soft brush.

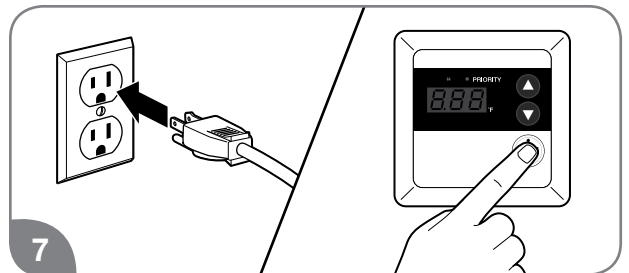

7
Turn on the water supply, reconnect the electrical supply, and turn on the water heater.

CARING FOR YOUR WATER HEATER



Preventive Maintenance

⚠WARNING: Failure to perform routine preventive maintenance can prevent the water heater from operating properly. Improper operation can cause carbon monoxide dangers, excessive water temperatures, and other potentially hazardous conditions resulting in death, personal injury, and/or product damage.

Properly maintaining your water heater will ensure dependable, trouble-free service.

User Preventive Maintenance

Establish and follow a routine preventive maintenance program. The following suggested items should be included in your program.



- Monthly check and clean the water filter. See “Water Filter Cleaning” on page 17.

⚠WARNING: Hot water is released during manual operation of the relief valve. Make sure all people and animals are clear from the area before performing this check to prevent death, personal injury, and/or property damage from hot drain water.

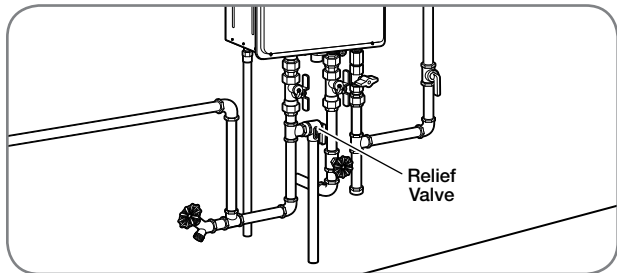

- Annually check the operation of the pressure-relief valve. Lifting the lever handle on the pressure-relief valve opens the valve to flush hot water through the discharge line to the drain. After several gallons have drained, release the lever handle to close the valve and stop draining.

NOTICE: If the pressure relief valve on the hot water heater discharges periodically, this may indicate a problem in the water system. Contact the water supplier or a plumbing contractor to correct the problem. DO NOT plug the relief valve outlet.

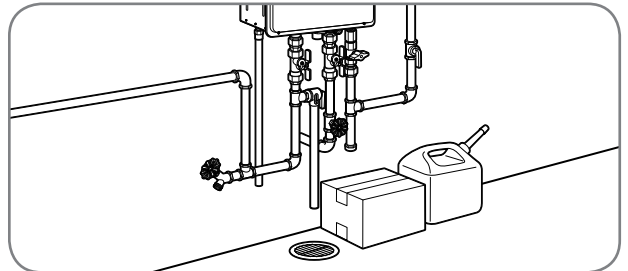

- Inspect and keep the area around the water heater clear and free of flammable materials, such as gasoline and other flammable vapors and liquids.
- Visually inspect the water heater for damage and/or denting. If present, contact a service personnel to verify proper operation.
- Check for abnormal sound during normal operation (e.g., hissing or banging noises). Contact a qualified service technician or plumbing contractor.
- Check all gas and water pipes for leaks. See page 55.

NOTICES:

- DO NOT operate the water heater if you feel something is wrong with the unit.
- DO NOT allow children to operate or handle the unit.
- After inspections, maintenance, and/or cleaning, ensure proper operation by turning on a hot water faucet.

Professional Preventive Maintenance

It is recommended that a periodic inspection of the water heater burner, relief valve, air intake filter, water filter, and venting system be made by a qualified service technician.

CARING FOR YOUR WATER HEATER



Draining the Water Heater

⚠ WARNING: Failure to follow these draining instructions can cause serious personal injury from scalding and/or product damage.

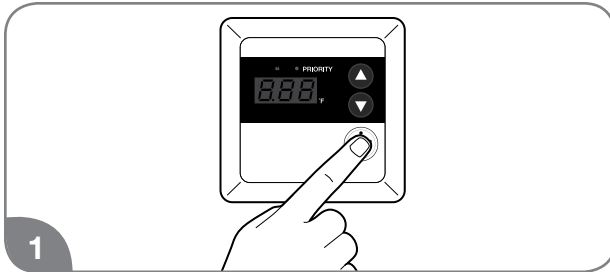

1 Turn off the water heater by pressing the POWER ON/OFF button on the control panel.

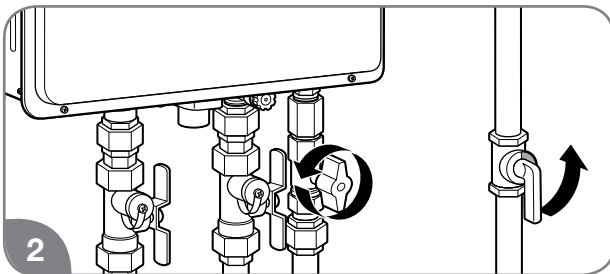

2 Close the gas shut-off valve(s).

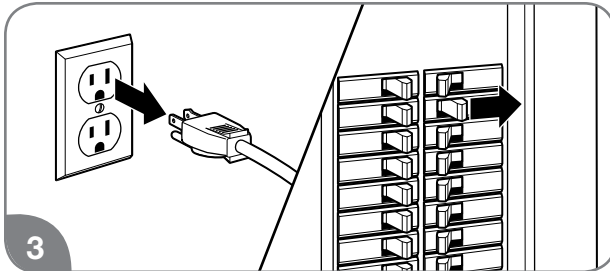

3 At least 10 seconds after Step 1, unplug the water heater or disconnect the power supply at the circuit breaker box.

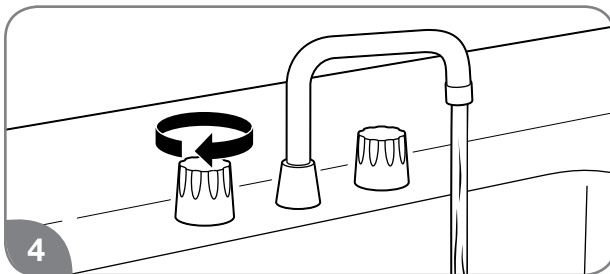

4 Open all hot water faucets. Run the water until it is COLD; then shut off the faucet.

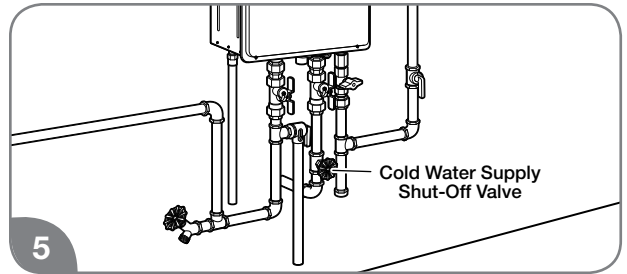

5 Close the water shut-off valve.

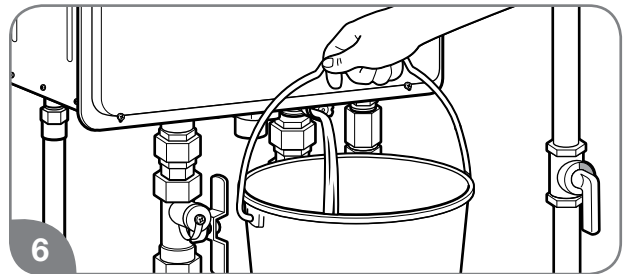

6 Using a suitable container to catch the water, remove the water filter from the base of the cold water inlet line.

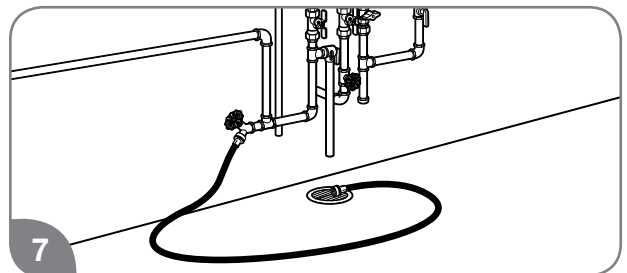

7 Connect a garden hose to the drain valve in the hot water outlet line and place the other end in a suitable drain. Open the drain valve until all the water has drained from the water heater. Leave water heater as is until placed back in service.

CARING FOR YOUR WATER HEATER

⚠ CAUTION: Even when drained properly, a small amount of water will remain in the water heater. In cold weather conditions, this water can freeze. If this happens, allow the defrost protection on the water heater at least 30 minutes to melt the frozen water. The water heater will not work properly until this water is thawed.

To put the water heater back in service:

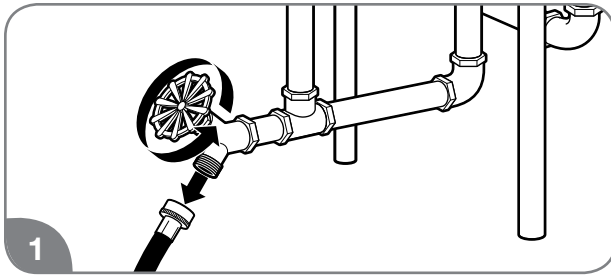

1 Disconnect drain hose. Make sure the drain valve is closed.

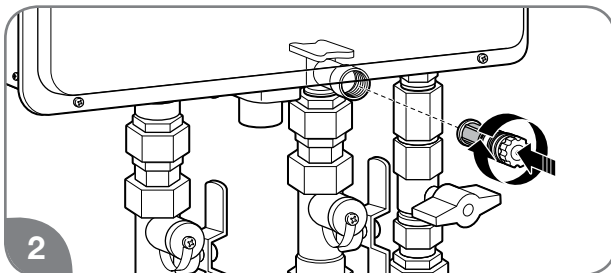

2 Reinstall the water filter in the base of the cold water inlet line.

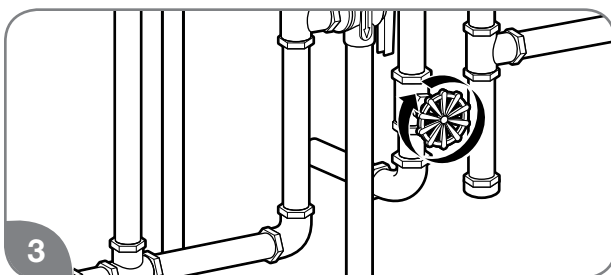

3 Open the water shut-off valve.

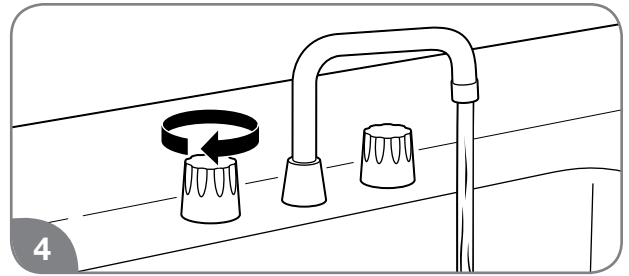

4 Open all hot water faucets and let run until all air has been purged from the lines.

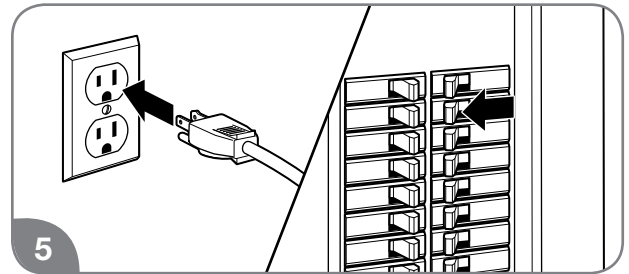

5 Plug in the power cord or reconnect the power supply at the circuit breaker box.

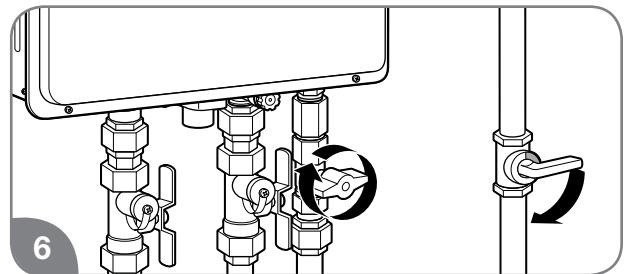

6 Open the gas shut-off valve(s).

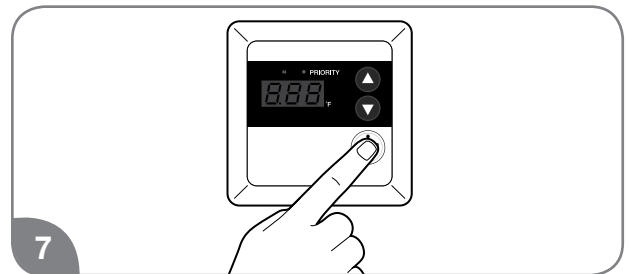

7 Press the POWER ON/OFF button on the control panel to restart the unit.

CARING FOR YOUR WATER HEATER



Draining the Water Heater (cont.)

Standard Drain Method

Service isolator valve kits may be purchased from the manufacturer, distributor, or place of purchase. The kits include two full-port isolation valves to be used in the inlet and outlet water lines. These kits provide a means for full diagnostic testing and ease of system flushing.

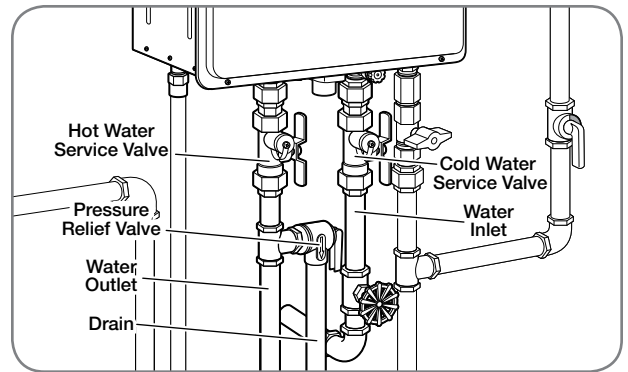

Freeze Protection

⚠️ WARNING: Failure to drain the water heater can cause serious personal injury from scalding and/or product damage.

Whenever the water heater may be exposed to freezing conditions, make sure to completely drain the water from the unit. See page 20.

Freezing conditions come from the ventilation system on direct-vent models and from exposure to cold air on outdoor models.

All of these water heaters are equipped with a freeze protection electric heater. This heater prevents freezing inside the water heater down to an ambient temperature of approximately -30°F (-34°C). These temperatures are all based on temperatures without wind.

The heater only protects the internal components of the water heater.

NOTICE: Unplugging or disconnecting the power supply to the water heater will also disconnect the power to the heater.

External piping and valves require additional freeze protection. One method is to wrap insulation around the piping and valves.

Another method is to turn on a hot water faucet and leave a small amount of water running at a faucet. This will protect the water heater, piping, and valves from freezing.

Running Water Freeze Protection

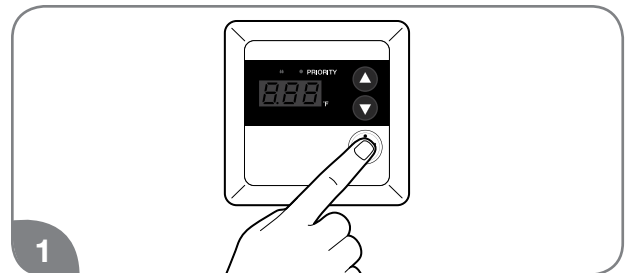

Turn off the water heater by pressing the POWER ON/OFF button on the control panel.

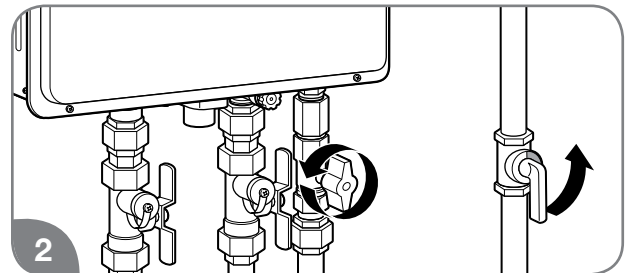

Close the gas shut-off valve(s).

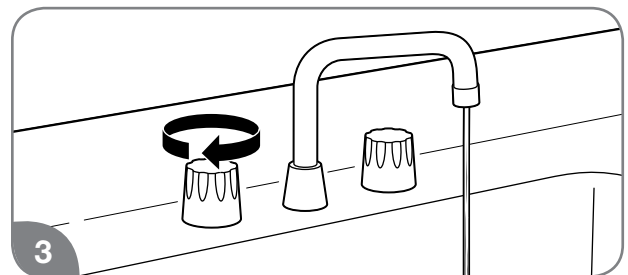

Open a hot water faucet slightly until the water stream is approximately 1/8 in. (0.3 cm). Be sure to check the flow periodically.

CARING FOR YOUR WATER HEATER



Vacation and Extended Shutdown

⚠️ WARNING: Failure to drain the water heater can cause serious personal injury from scalding and/or product damage.

If the water heater is to remain idle for an extended period of time, the power and water to the heater should be turned off.

The water heater and piping should be drained if they might be subjected to freezing temperatures. See “Freeze Protection” section on page 22.

After an extended shutdown, the water heater’s operation and controls should be checked by a qualified service technician.



Troubleshooting Chart

The information in the following troubleshooting chart may help you diagnose and/or fix a problem you may be experiencing. Please review this chart before calling for service assistance.

⚠️ DANGER: Shock Hazard – Make certain power to the water heater is OFF before removing protective cover for any reason. Electric shock will cause death or serious personal injury.

⚠️ WARNING: For Your Safety, DO NOT attempt repair of electrical wiring, gas piping remote control, burners, vent connectors, or other safety devices. Refer repairs to a qualified service technician.

Problem	Possible Cause	Solution
	1. Unit is not ON.	1. Turn on the unit by pressing the POWER ON/OFF button.
	2. Water shut-off valve is not completely opened.	2. Check shut-off valve and open completely.
	3. Hot water faucet is not completely opened.	3. Open hot water faucet completely. (The main burner goes off when incoming water volume is inadequate.)
	4. Water piping is frozen.	4. Allow piping to thaw.
	5. Electrical power is disconnected or water supply is shut off.	5a. Plug in the power cord or reconnect the power supply at the circuit breaker box. 5b. Completely open the water supply valve. (Inadequate water volume will cause the main burner to turn off.)
	6. The temperature may be set too low.	6. Increase the temperature setting.
	7. Mixing valve malfunctions (if applicable).	7. Check and replace the mixing valve.
	8. Error code displayed on the remote control.	8. See “Service Error Code Chart” on page 26. If required, contact a qualified service technician.
	9. Not enough water demand.	9. Increase the hot water flow at the faucet.
	10. Water filter is clogged or dirty.	10. Clean the water filter. (See page 17.)
	11. Fixture aerator is clogged or dirty.	11. Clean the aerator.
	12. Scale buildup in the heat exchanger.	12. Check for error code. If required, contact a qualified service technician.
	13. Hot and cold water lines reversed.	13. Reverse the water lines.

CARING FOR YOUR WATER HEATER

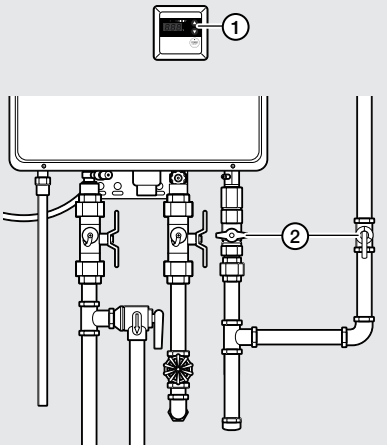
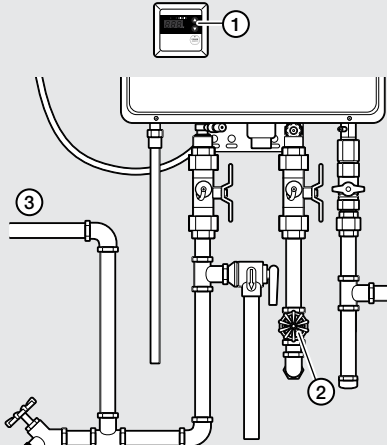

Troubleshooting Chart (cont.)

Problem	Possible Cause	Solution
<p>Water not hot enough.</p> 	<ol style="list-style-type: none"> The temperature may be set too low. The gas valve is not completely opened. Gas supply pressure is low. Bleed-over in one of the hot water fixtures. 	<ol style="list-style-type: none"> Increase the temperature setting at the remote control. Check and completely open the gas valve. Contact your gas utility company or gas contractor to verify the gas meter and gas piping size. Contact a dealer or a qualified service technician.
<p>Water too hot.</p> 	<ol style="list-style-type: none"> Temperature is set too high. Water shut-off valve is not completely opened. Small amount of water has been heated. 	<ol style="list-style-type: none"> Decrease the temperature setting at the remote control. Check and completely open the water shut-off valve. Increase the hot water flow at the faucet to allow more water to flow through the water heater.
<p>Fan continues to rotate after the hot water faucet is closed.</p>	<p>The post-purge cycle clears flue gases.</p>	<p>Normal operation.</p>

CARING FOR YOUR WATER HEATER



Service Error Code Chart

Your water heater has an electronic diagnostic system built into it. When the water heater finds a problem, it displays an error code in the LED display on the remote control. The following chart lists the error codes along with their possible problem and solution. Using this chart may help you diagnose and/or fix a problem you may be experiencing. Please refer to this chart before calling for service assistance.

⚠ DANGER: Shock Hazard – Make certain power to the water heater is OFF before removing protective cover for any reason. Electric shock will cause death or serious personal injury.

⚠ WARNING: For Your Safety, DO NOT attempt repair of electrical wiring, gas piping, remote control, burners, vent connectors, or other safety devices. Refer repairs to a qualified service technician.

When an error code is displayed:

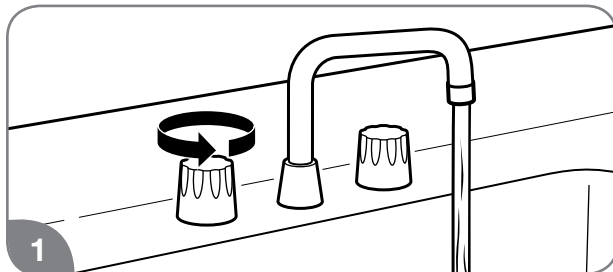

1 Turn off all the hot water faucets.

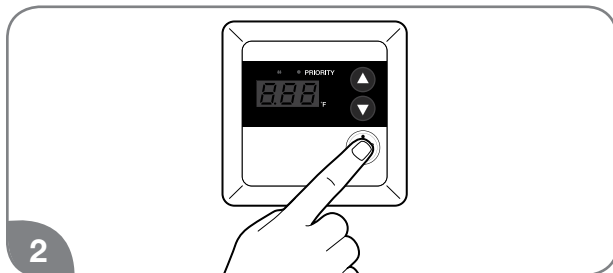

2 Turn off the water heater by pressing the POWER ON/OFF button on the remote control.

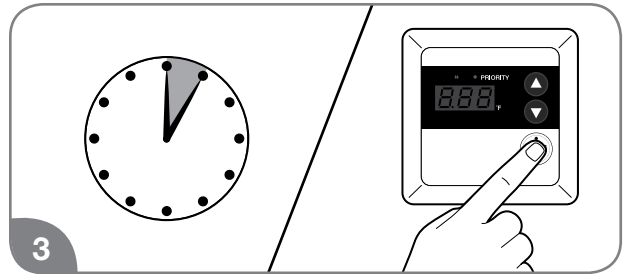

3 Wait about 5 minutes; then restart the water heater by pressing the POWER ON/OFF button.

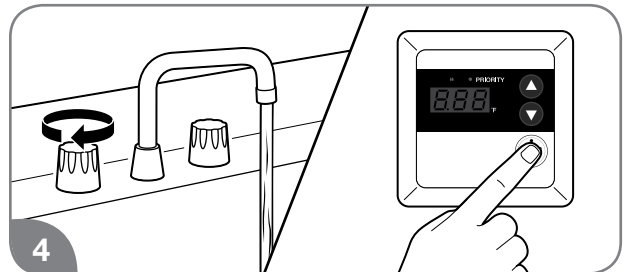

4 Turn on a hot water faucet and recheck the remote control display.

If the error code remains in the display:

1. Turn off the hot water faucet.
2. Turn off the water heater.
3. Follow the error code chart information.
4. Restart the water heater, turn on a hot water faucet, and recheck the remote control display.

If the error code is still shown:

1. Turn off the hot water faucet.
2. Turn off the water heater.
3. Make note of the displayed error code and call for service assistance. See “Call for Assistance” section on page 26.

NOTICE: If the displayed error code is not listed in the chart, immediately turn off the water heater and call for service assistance.

CARING FOR YOUR WATER HEATER



Service Error Code Chart (cont.)

Error Code	Possible Cause	Solution
1L	Water heater has buildup of lime deposits.	Contact a dealer or qualified service technician.
05	Air intake or vent exhaust opening may be blocked.	Remove any blockage. (Air intake requires 12 in. [30 cm] of clearance.)
	The vent pipes on the vent termination may not be connected properly.	Contact a dealer or qualified service technician.
11	The gas shut-off valve is not fully opened.	Check shut-off valve and open completely.
12	Gas service has been interrupted.	Contact your gas utility company.
	LP gas is running low (LP models only).	Refill or replace your LP gas container.
13	If this code is still displayed after taking the numbered steps above.	Contact a dealer or qualified service technician.
14	Water heater is overheating.	Contact a dealer or qualified service technician.
15	The heat exchanger is too hot.	Check for blockage in the vent. Contact a dealer or qualified service technician.
29	Neutralizer is clogged.	Contact a dealer or qualified service technician.
31	Faulty inlet thermistor.	Contact a dealer or qualified service technician.
33	Faulty outlet thermistor.	Contact a dealer or qualified service technician.
61 or 99	Faulty blower motor.	Contact a dealer or qualified service technician.
65	Faulty water flow solenoid.	Contact a dealer or qualified service technician.
92	The neutralizer needs to be replaced soon.	The unit can be used for a while, but contact a dealer or qualified service technician.
93	The neutralizer must be replaced.	The unit cannot be used until the neutralizer is replaced. Contact a dealer or qualified service technician.
P1	Not enough water flow to operate the unit.	Increase the water flow from the fixtures.

IF YOU NEED SERVICE



Call for Assistance

- All questions, adjustments, repairs, and/or routine maintenance should be directed to your installer, plumbing contractor, or licensed service agent. If your contacts have moved or are not available, please refer to the telephone directory, commercial listings, or local utility company for qualified service assistance.
- If your problem has not been solved to your satisfaction, contact the Rheem National Service Department at the following address:
 Rheem
 National Service Department
 1241 Carwood Court
 Montgomery, Alabama 36117
 Phone: 1-800-432-8373

When contacting the manufacturer, the following information will be requested:

- Model and serial number. (See page 8 or the ratings plate on the front of the water heater.)
- Address where the water heater is located.
- Name and address of installation contractors (page 8) and all qualified service companies that have worked on the water heater.
- Original installation date. (See page 8.)
- Dates any service or preventive maintenance was performed.
- Details of the persisting problem.
- List of businesses that have tried to fix this problem, along with dates of service.

INSTALLATION INSTRUCTIONS FOR THE CONTRACTOR

INSTALLATION INSTRUCTIONS

Standards Compliance

This water heater must be installed in accordance with these instructions, local codes, and utility company requirements.

In the United States where local codes are not available, use the latest edition of the American National Standard/National Fuel Gas Code. A copy of the Fuel Gas Code can be purchased from either the American Gas Association, 400

North Capitol Street Northwest, Washington, DC 20001, as ANSI standard Z223.1, or National Fire Protection Association, 1 Batterymarch Park, MA 02269 as NFPA 54.

In Canada, use the latest edition of the CSA B149.1 Natural Gas and Propane Installation Code and the Canadian Electrical Code, CSA C22.1, Part 1.

Choosing a Location

⚠ WARNING: Fire Hazard –

Combustible construction refers to adjacent walls and ceilings and should not be confused with combustible or flammable products and materials. Combustible materials, such as clothing, cleaning materials, or flammable liquids, must not be placed against or next to the water heater. Fire or explosion could occur causing death, personal injury, and/or product damage.

A gas-fired water heater should never be installed in a space or room where liquids with flammable vapors are used or stored. Such liquids include gasoline, LP gas (butane or propane), paint, adhesives and their thinners, solvents, or removers. Flammable vapors carry long distances from where they are used or stored. The open flame of the water heater's main burner can ignite these vapors causing an explosion or fire.

NOTICE: Elevating a gas-fired water heater will reduce but NOT eliminate the possibility of lighting the vapor of flammable liquids which may be improperly stored or accidentally spilled.

NOTICE: This water heater should not be located in an area where leakage of the heat exchanger or connections will result in damage to the area adjacent to it or to lower floors of the structures. When such areas cannot be avoided, install a suitable catch pan with an adequate drain under the water heater. This drain pan must not restrict the combustion airflow.

The following requirements will ensure a safe installation:

- The water heater must be located in an area where it won't sustain damage from moving vehicles, flooding, etc. If the water heater is installed in a garage, the direct ignition system and main burner should be no less than 18 in. (45 cm) above the garage floor.
- The water heater should be installed as close as possible to the vent exhaust and air intake. This minimizes the vent length and the number of elbows and joints required for venting.
- The water heater should be installed with the proper venting and exhaust materials.

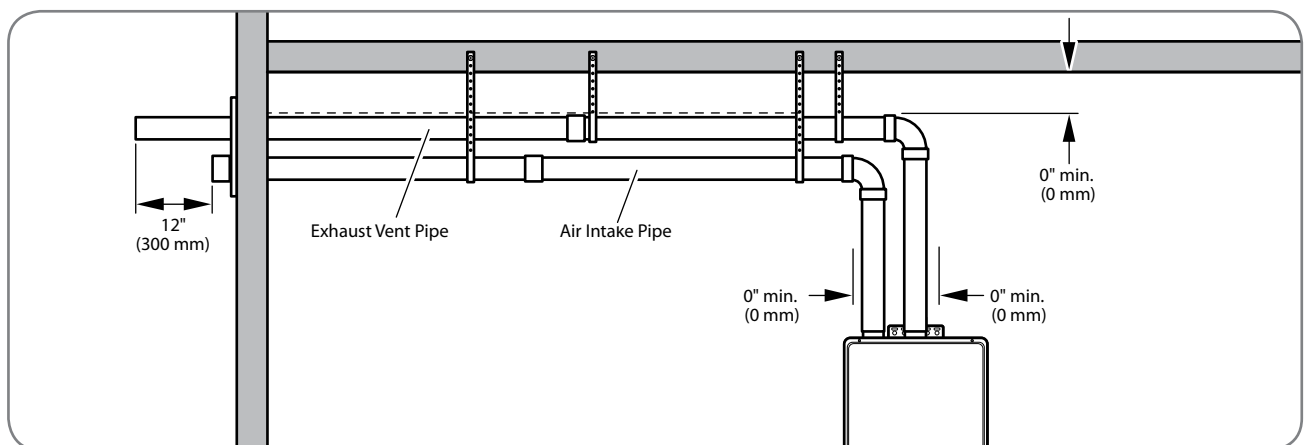

Choosing a Location (cont.)

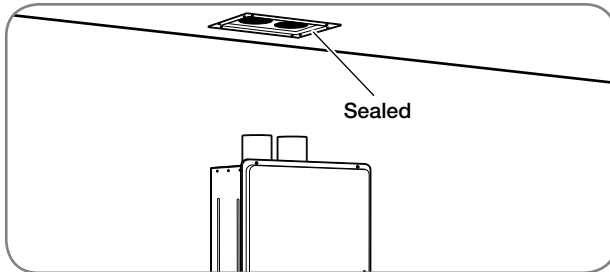

- Every penetration of a floor or ceiling should be sealed.
- Failure to install and properly vent the water heater to the outdoors as outlined on pages 33 through 46 can result in unsafe operation.

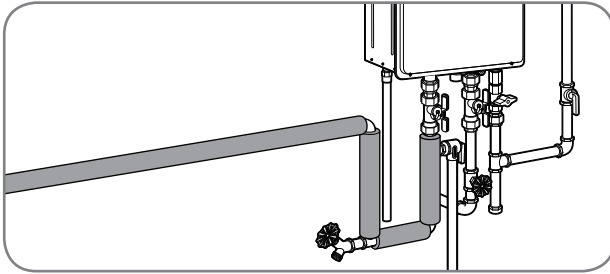

- Long hot water lines should be insulated to conserve water and energy.
- The water heater and water lines should be protected from exposure to freezing temperatures.



- **Do not** install the water heater outdoors or in bathrooms, bedrooms, or any occupied rooms normally kept closed.



- **Do not** install the water heater where it is subject to vibrations.



- **Do not** install the water heater in a recreational vehicle, mobile home, boat, or other watercraft.



- **Do not** install the water heater near vents for heating and cooling. If necessary, maintain a minimum clearance of 4 ft. (1.2 m).

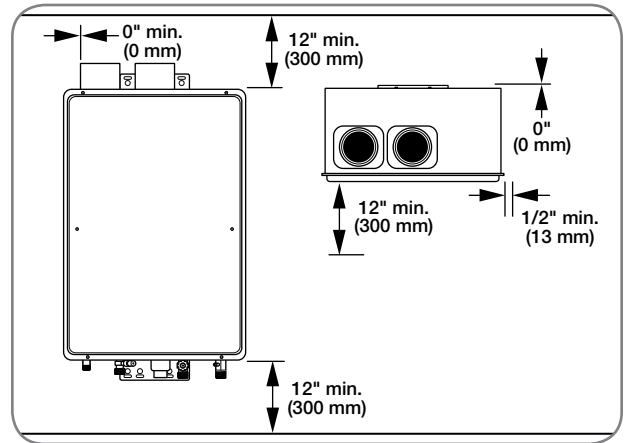

- Minimum water heater clearances from combustible and noncombustible construction are as follows:
 - 1/2 in. (1.3 cm) for sides
 - 0 in. (0 cm) for rear with support bracket(s)
 - 12 in. (30 cm) from the bottom, top, and front

INSTALLATION INSTRUCTIONS

Product Inspection

- Visually inspect the water heater for any possible damage.
- Check the rating plate on the water heater to make sure the water heater was designed to be used with the supplied type of gas (natural or LP).
- Verify that all included supplied parts are present as shown.

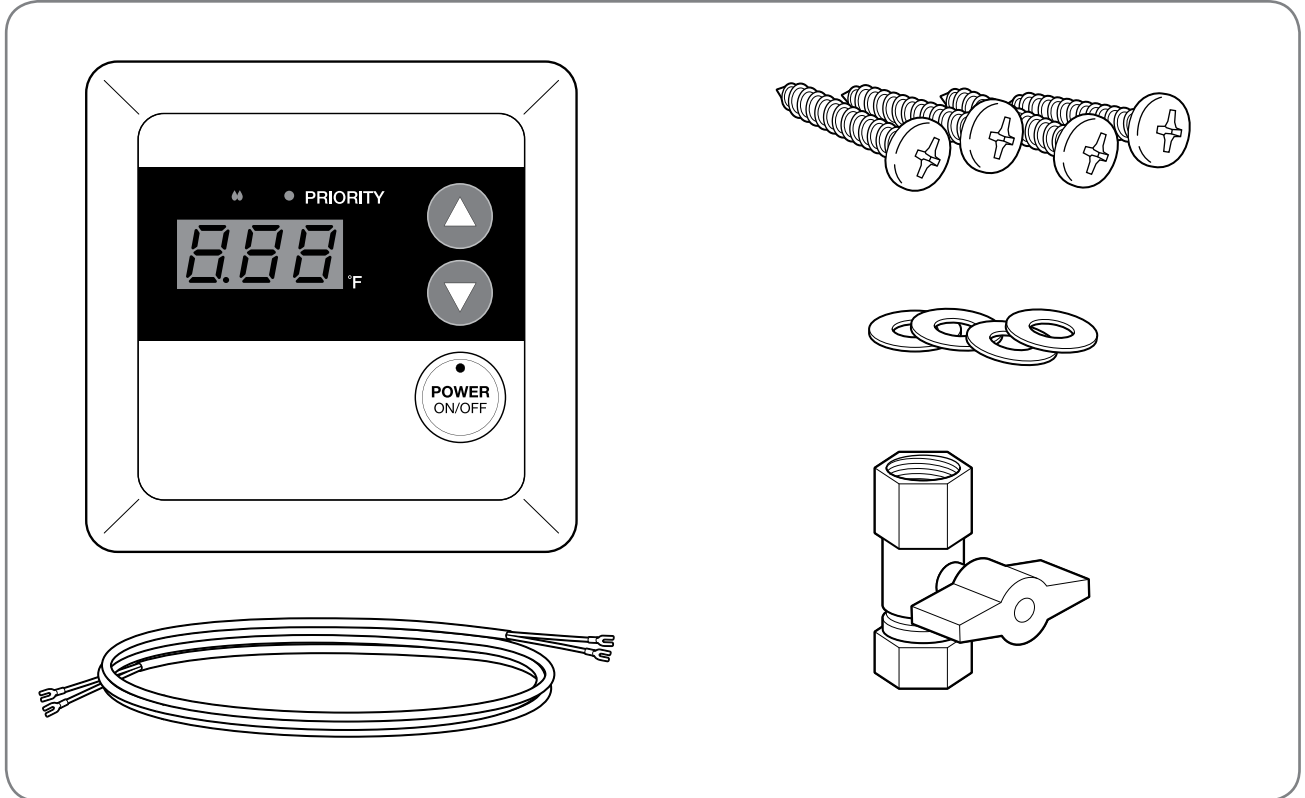

Water Heater Installation

Corrosive Atmosphere

NOTICE: The water heater should not be installed near an air supply containing halogenated hydrocarbons.

Avoid installing a water heater in any of the following locations: beauty shops, dry-cleaning establishments, photo processing labs, and storage areas for liquid and powdered bleaches or swimming pool chemicals. These locations often contain such halogenated hydrocarbons.

The air supply containing halogenated hydrocarbons is safe to breathe, but when passed through a gas flame, corrosive elements are released that will shorten the life of any gas-burning appliance.

Propellants from common spray cans or gas leaks from A/C and refrigeration equipment are highly corrosive after passing through a flame.

The water heater warranty is void when the failure is due to operation in corrosive conditions.

INSTALLATION INSTRUCTIONS



Water Heater Installation (cont.)

NOTICE: The National Fuel Gas Code (NFGC) and CSA B149.1 mandate a manual gas shut-off valve. See NFGC/B149.1 for complete instructions. Local codes or plumbing authority requirements may vary from the instructions or diagrams provided and take precedence over these instructions.

Typical Installation of Direct-Vent Water Heater (Venting Required)

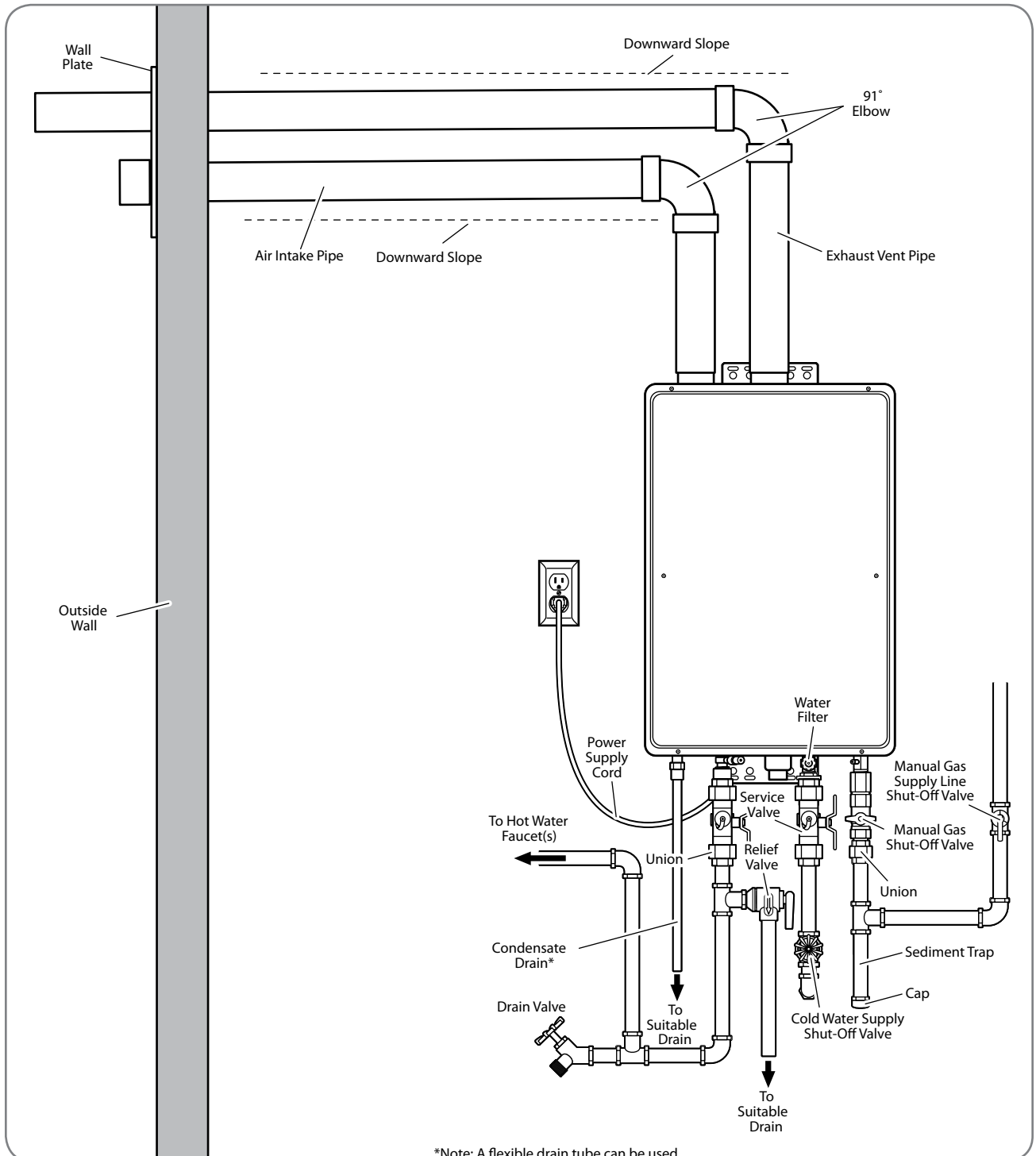

*Note: A flexible drain tube can be used

INSTALLATION INSTRUCTIONS

General

Water Heater Installation (cont.)

Typical Installation of Outdoor Water Heater (No Venting Required)

This water heater is for OUTDOOR installation only.

⚠ WARNING: DO NOT install this water heater indoors or in an enclosure. It is designed for outdoor installation only. Any other type of installation can result in death, personal injury, and/or damage to the product or property.

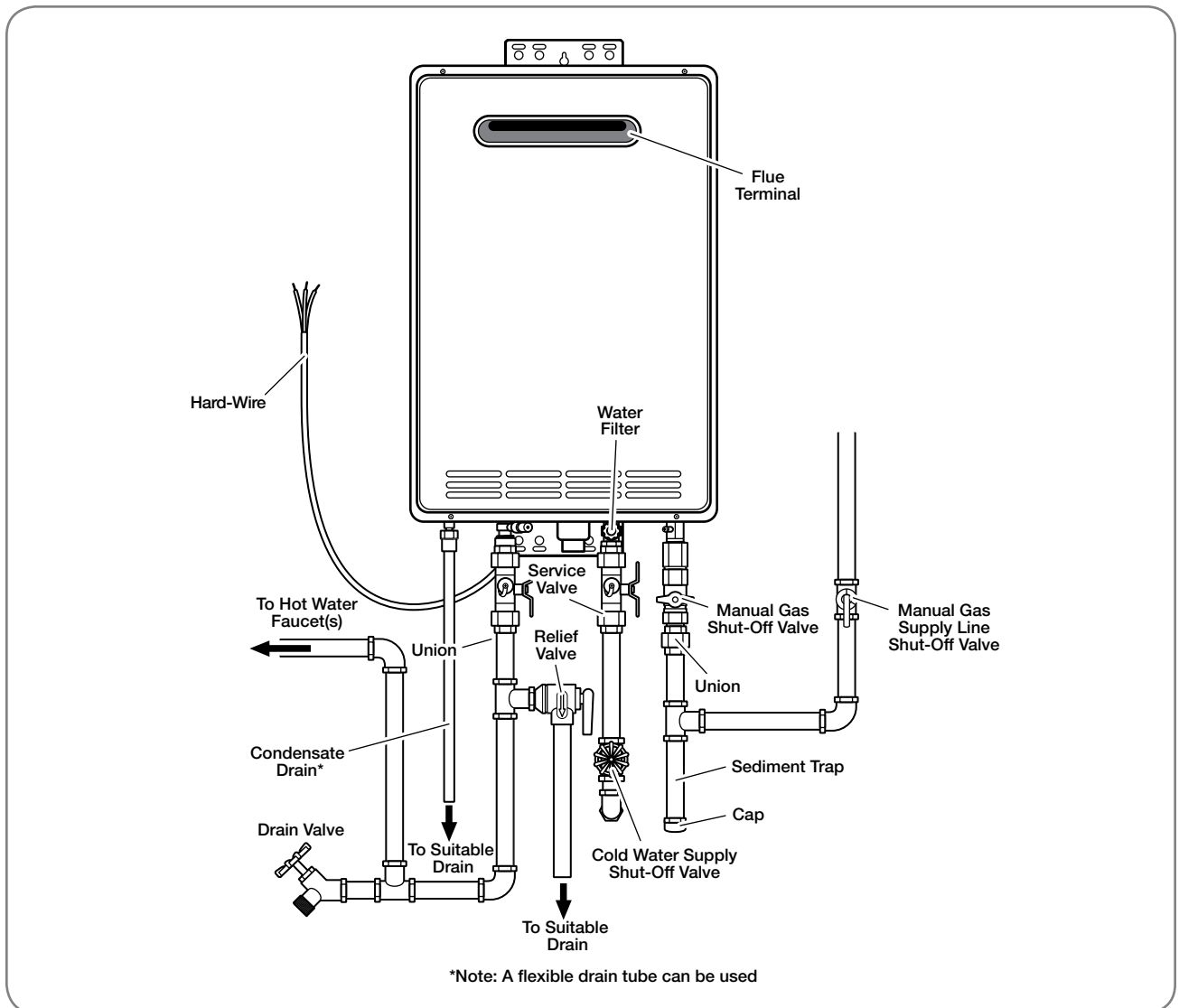

INSTALLATION INSTRUCTIONS

Mounting the Water Heater

⚠ CAUTION: Reinforcement of the wall is required in case the wall is not strong enough to hold the water heater. Failure to do so could result in personal injury and/or product damage.

The mounting location for the water heater should allow for easy access and operation.

Always mount the water heater at the wall studs, or into a suitable piece of wood that spans the distance between the wall studs. This piece of wood can be installed inside or outside of the wall. Use wood screws to secure brackets to wall. If mounting to dry wall or concrete wall, use drywall anchors or lag bolts.

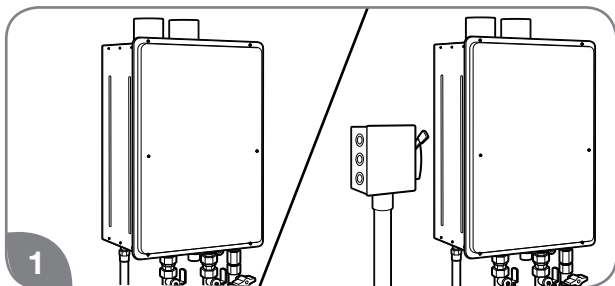

1 Make sure the proper electrical outlet or supply (120 VAC/60 Hz) is available and located near the unit. Direct-vent models come with a 6-ft. (1.8-m) power cord, while the outdoor models require hard-wiring or the addition of a plug.

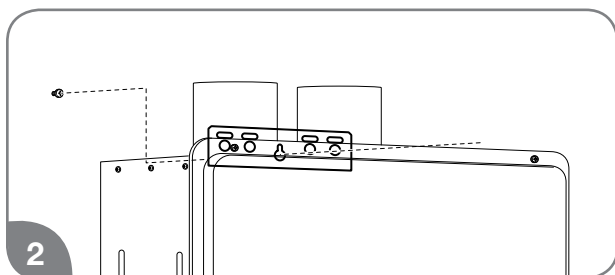

2 Position the upper mounting bracket and partially install the center mounting screw. The clearance between the screw head and the wall should be about 1/8 in. (0.3 cm). Hang the upper bracket on the screw.

NOTICE: The image above may differ in appearance from your water heater.

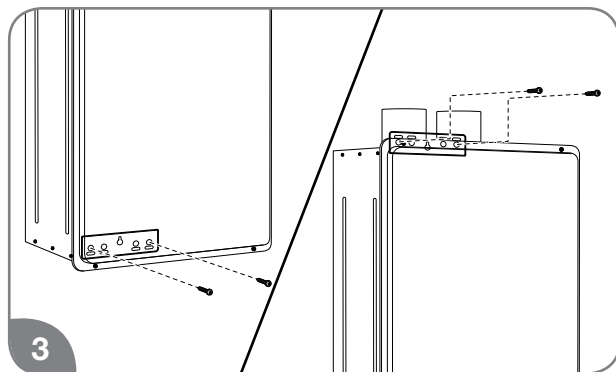

3 Using two mounting screws and washers, secure the lower mounting bracket to the wall. Then, secure the upper mounting bracket to the wall with two mounting screws and washers.

INSTALLATION INSTRUCTIONS



Venting for Direct-Vent Water Heater

⚠ DANGER: Failure to properly vent the water heater to the outdoors as outlined in this Venting section will result in death or serious personal injury. To avoid the risk of fire, explosion, or asphyxiation from carbon monoxide, NEVER operate the water heater unless it is properly vented and has adequate air supply for proper operation as outlined in this Venting section.

⚠ WARNING: Refer to page 29 for required clearances to combustible materials. Improper clearances can cause explosion or fire resulting in death, personal injury, and/or product damage.

- ⚠ CAUTIONS:**
- Check to make sure flue gases do not recirculate into the air intake terminal when using direct venting. If the water heater is having service issues, flue recirculation may be a contributing factor.
 - Even when the minimum vent terminal separation distances are followed, recirculation may still occur depending upon the location outside the building, the distance from other buildings, proximity to corners, weather conditions, wind patterns, and snow depth.
 - Periodically check to make sure that flue recirculation is not occurring. Signs of flue gas recirculation include frosted or frozen intake terminals and condensate in the intake terminal and venting system.
 - Correction to flue recirculation may involve angling the intake away from the exhaust terminal and increasing the distance between them. Check to be sure the intake and exhaust terminals are not obstructed, especially during periods of below-freezing weather.

Venting Requirements

The installation of venting must comply with national codes, local codes, and the vent manufacturer's instructions.

The vent exhaust and air intake must be vented outside as described in these instructions. DO NOT vent this water heater through a chimney. It must be vented separately from all other appliances.

NOTICE: The unit can be vented using only the following recommended pipe material. Use only 2- or 3-inch diameter pipe. Refer to local codes for restrictions on the use of PVC, CPVC, or ABS pipe and fittings. All exhaust venting materials for product installed in Canada must meet ULC-S636.

Acceptable materials or equivalent:
PVC (Schedule 40, ASTM D-1785)
CPVC (Schedule 40, ASTM F-441)
ABS (Schedule 40, ASTM D-2661) (Not permitted

in Canada)

The fittings, other than the VENT TERMINAL, should be equivalent to the following:

- PVC (Schedule 40 DWV, ASTM D-2665)
- CPVC (Schedule 40 DWV, ASTM F-438)
- ABS (Schedule 40 DWV, ASTM D-2661) (Not permitted in Canada)
- Polypropylene
- Category III Stainless Steel

DO NOT USE Schedule 20, Cell Core, Drain Pipe, Galvanized, Aluminum, or B-Vent.

Recommended Vent Lengths

Before starting the vent installation, careful planning should be given to the routing and termination of the vent pipes. The length of the vent pipes (inlet and outlet) should be kept to a minimum. Also, see pages 37–38 and 44 for vent terminal placement. Refer to the maximum and minimum vent length charts for the pipe sizes that can be used and the total equivalent length of pipe that can be used. Do not exceed equivalent length of pipe in maximum vent length chart.

Maximum Vent Length (intake/outlet):

Number of 90° Elbows	Maximum Length of 2" Straight Pipe	Maximum Length of 3" Straight Pipe
0 or 1	5.0 ft. (1.5 m)	38.0 ft. (11.6 m)
2	3.5 ft. (1.0 m)	36.5 ft. (11.1 m)
3	2.0 ft. (0.6 m)	35.0 ft. (10.6 m)
4	Not available	33.5 ft. (10.2 m)
5	Not available	32.0 ft. (9.8 m)
6	Not available	30.5 ft. (9.3 m)

The system will not operate if there is excessive restriction (pressure drop) in the venting system. Use the chart above to calculate the maximum pipe run length with the required number of elbows (e.g., a maximum 38 ft. [12 m] of 3" vent pipe may be used provided there is only one 90° elbow in the system).

A 90° elbow is equivalent to 1 ft. 6 in. (0.5 m) of straight pipe.

The vent termination does not count as part of the straight pipe equivalent when determining the total vent length.

Minimum Vent Length:

Number of 90° Elbows	Minimum Length of 2" Straight Pipe	Minimum Length of 3" Straight Pipe
1	1.0 ft. (0.3 m)	1.0 ft. (0.3 m)

INSTALLATION INSTRUCTIONS

NOTICE: To use 2-inch vent pipe, a reducing adapter or bushing will be required.

Depending on the size of pipe that is chosen for venting the water heater, it might be necessary to use a fitting for stepping down in pipe size, to connect to the water heater.

All intake and exhaust venting components must have the same diameter size. Do not use a different size on the intake and exhaust venting.

The unit may be vented horizontally through a wall or vertically through the roof. Pipe runs must be adequately supported along both vertical and horizontal runs. Maximum unsupported span is recommended to be no more than 4 feet (1.2 m). It is imperative that the first hanger be located on the horizontal runs immediately adjacent to the first 90-degree elbow from the vertical rise. Only use support isolation hanging bands. DO NOT use wire to support pipe runs.

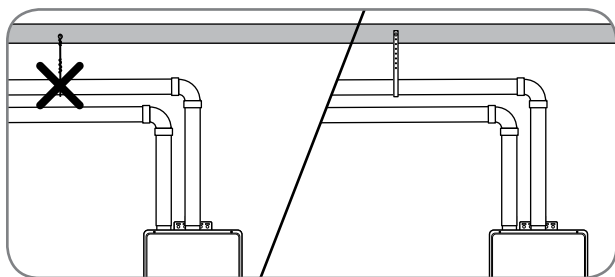

Stress levels in the pipe and fittings can be significantly increased by improper installation. If rigid pipe clamps are used to hold the pipe in place, or if the pipe cannot move freely through a wall penetration, the pipe may be directly stressed, or high thermal stresses may be formed when the pipe heats up and expands. Install accordingly to minimize such stresses.

Preexisting Venting Notes:

If the water heater is being installed as a replacement for an existing water heater, a thorough inspection of the existing venting and air intake system must be performed prior to any installation work. Verify that the correct materials, vent lengths, and terminal locations as described in this manual have been met. Carefully inspect the entire venting and air intake system for any signs of cracks or fractures, particularly at the joints between elbows or other fittings and the straight runs of vent pipe. Check the system for signs of sagging or other stresses in the joints as a result of misalignment of any components in the system. If any of these conditions are found, they must be corrected in accordance with the venting instructions in this manual before completing the installation and putting the water heater into service.

NOTICES:

- It is recommended that the air intake and exhaust pipes have a 1/4" per foot downward slope toward the end of the pipes.
- Maintain the proper clearance between the vent pipe and combustible or noncombustible materials as described on page 29.
- Maintain a 0-in. (0-cm) minimum clearance required between the air intake pipes and combustible material.
- Use proper support for the vent and air intake pipes.
- Support method used should isolate the vent pipe from floor joists or other structural members. This helps prevent transmission of noise and vibration.
- **Do not** support, pin, or otherwise secure the venting system in a way that restricts the normal thermal expansion and contraction of the chosen venting material.

See page 36 for additional requirements for the Commonwealth of Massachusetts.

INSTALLATION INSTRUCTIONS



Venting for Direct-Vent Water Heater (cont.)

In the Commonwealth of Massachusetts

The Commonwealth of Massachusetts requires compliance with regulation 248 CMR 4.00 and 5.00 for installation of through-the-wall vented gas appliances as follows:

5.08: Modifications to NFPA-54, Chapter 10

- (1) Revise NFPA-54 section 10.5.4.2 by adding a second exception as follows:

Existing chimneys shall be permitted to have their use continued when a gas conversion burner is installed, and shall be equipped with a manual reset device that will automatically shut off the gas to the burner in the event of a sustained back-draft.

- (2) Revise 10.8.3 by adding the following additional requirements:

(a) For all side-wall, horizontally vented, gas-fueled equipment installed in every dwelling, building, or structure used in whole or part for residential purposes, including those owned or operated by the Commonwealth and where the side-wall exhaust vent termination is less than seven (7) feet above finished grade in the area of the venting, including but not limited to decks and porches, the following requirements shall be satisfied.

1. **INSTALLATION OF CARBON MONOXIDE DETECTORS.** At the time of installation of the side-wall, horizontally vented, gas-fueled equipment, the installing plumber or gas fitter shall observe that a hard-wired carbon monoxide detector with an alarm and battery backup is installed on the floor level where the gas equipment is to be installed. In addition, the installing plumber or gas fitter shall observe that a battery-operated or hard-wired carbon monoxide detector with an alarm is installed on each additional level of the dwelling, building, or structure served by the side-wall, horizontally vented, gas-fueled equipment. It shall be the responsibility of the property owner to secure the services of qualified licensed professionals for the installation of hard-wired carbon monoxide detectors.

a. In the event that the side-wall, horizontally vented, gas-fueled equipment is installed in a crawl space or an attic, the hard-wired carbon monoxide detector with alarm and battery backup may be installed on the next adjacent floor level.

b. In the event that the requirements of this subdivision cannot be met at the time of completion of installation, the owner shall have a period of thirty (30) days to comply with the above requirements, provided, however, that during said thirty (30) day period, a battery-operated carbon monoxide detector with an alarm shall be installed.

2. **APPROVED CARBON MONOXIDE DETECTORS.** Each carbon monoxide detector as required in accordance with the above provisions shall comply with NFPA 720 and be ANSI/UL 2034-listed and IAS-certified.

3. **SIGNAGE.** A metal or plastic identification plate shall be permanently mounted to the exterior of the building at a minimum height of eight (8) feet above grade directly in line with the exhaust vent terminal for the horizontally vented, gas-fueled heating appliance or equipment. The sign shall read, in print size no less than one-half (1/2) inch in size, "GAS VENT DIRECTLY BELOW. KEEP CLEAR OF ALL OBSTRUCTIONS."

4. **INSPECTION.** The state or local gas inspector of the side-wall, horizontally vented, gas-fueled equipment shall not approve the installation unless, upon inspection, the inspector observes carbon monoxide detectors and signage installed in accordance with the provisions of 248 CMR 5.08 (2)(a)(1 through 4).

(b) **EXEMPTIONS:** The following equipment is exempt from 248 CMR 5.08 (2)(a)(1 through 4):

1. The equipment listed in Chapter 10 entitled "Equipment Not Required To Be Vented" in the most current edition of NFPA 54 as adopted by the Board, and
2. Product-approved side-wall, horizontally vented, gas-fueled equipment installed in a room or structure separate from the dwelling, building, or structure used in whole or in part for residential purposes.

(c) **MANUFACTURER REQUIREMENTS – GAS EQUIPMENT VENTING SYSTEM PROVIDED.** When the manufacturer of product-approved side-wall, horizontally vented, gas-fueled equipment provides a venting system design or venting system components with the equipment, the instructions provided by the manufacturer for installation of the equipment and the venting system shall include:

1. Detailed instructions for the installation of the venting system design or the venting system components; and
2. A complete parts list for the venting system design or venting system.

(d) **MANUFACTURER REQUIREMENTS – GAS EQUIPMENT VENTING SYSTEM NOT PROVIDED.** When the manufacturer of product-approved side-wall, horizontally vented, gas-fueled equipment does not provide the parts for venting the flue gases, but identifies "special venting systems," the following requirements shall be satisfied by the manufacturer:

1. The referenced "special venting systems" instructions shall be included with the appliance or equipment installation instructions, and
2. The "special venting systems" shall be product-approved by the Board, and the instructions for that system shall include a parts list and detailed installation instructions.

(e) A copy of all installation instructions for all product-approved side-wall, horizontally vented, gas-fueled equipment, all venting instructions, all parts lists for venting instructions, and/or all venting design instructions shall remain with the appliance or equipment at the completion of the installation.