



“CMP COMBO” Metered Series

AUTOMATIC WATER CONDITIONERS

INSTALLATION, OPERATION, AND MAINTENANCE MANUAL

FILL IN FOR FUTURE REFERENCE

MODEL NO: _____

SERIAL NO: _____

DATE INSTALLED: _____

DEALER: _____

SPECIFICATION TABLE

Model Number	Units	CMP-30 COMBO	CMP-45 COMBO	CMP-60 COMBO
Exchange Capacity Kilograms	MAX	30.00	45.00	60.00
	MID	N/A	37.00	49.00
	MIN	N/A	29.00	39.00
Salt Per Regeneration Lbs. / Regen.	MAX	15.00	22.50	30.00
	MID	N/A	15.50	20.00
	MIN	N/A	7.50	10.00
Max Service Flow (1)	GPM	12.00	14.00	16.00
Pipe Size In - Out Drain	INS	1"	1"	1"
	INS	¾"	¾"	¾"
Operating Pressure Range	PSI	30-125	30-125	30-125
Maximum Operating Temperature	DEG F	110	110	110
Mineral Tank Size (Dia. x Ht.) (2)	INS.	10 x 47	12 x 52	13 x 54
Brine Tank (Dia. x Ht. (3)	INS.	18 x 33	18 x 33	18 x 40
Salt Storage	LBS.	450	375	450
Resin Volume	CU FT.	1.00	1.5	2.00
Electrical	VOLT. / FREQ.	120 Volts 60 Hz		
Injector	COLOR / CODE	White/E	Blue/F	Yellow/G
Shipping Weight	LBS.	110	187	197
Floor Space	INS.	13 x 20	31 x 18	32 x 18
Overall Ht.	INS.	55	60	62
Max. Drain Flow During Regeneration	GPM	1.3	2.2	3.2
Regeneration Waste Volume (6)	GAL.	60	95	120

NOTE:

- (1) Pressure drop at 15 psi.
- (2) Pressure vessels are seamless and made of reinforced fiberglass, pressure-tested at 300 psi.
- (3) Brine tanks are fabricated of seamless, rigid, tough, high-impact, non-toxic polyethylene.
- (4) 50 psi inlet pressure.

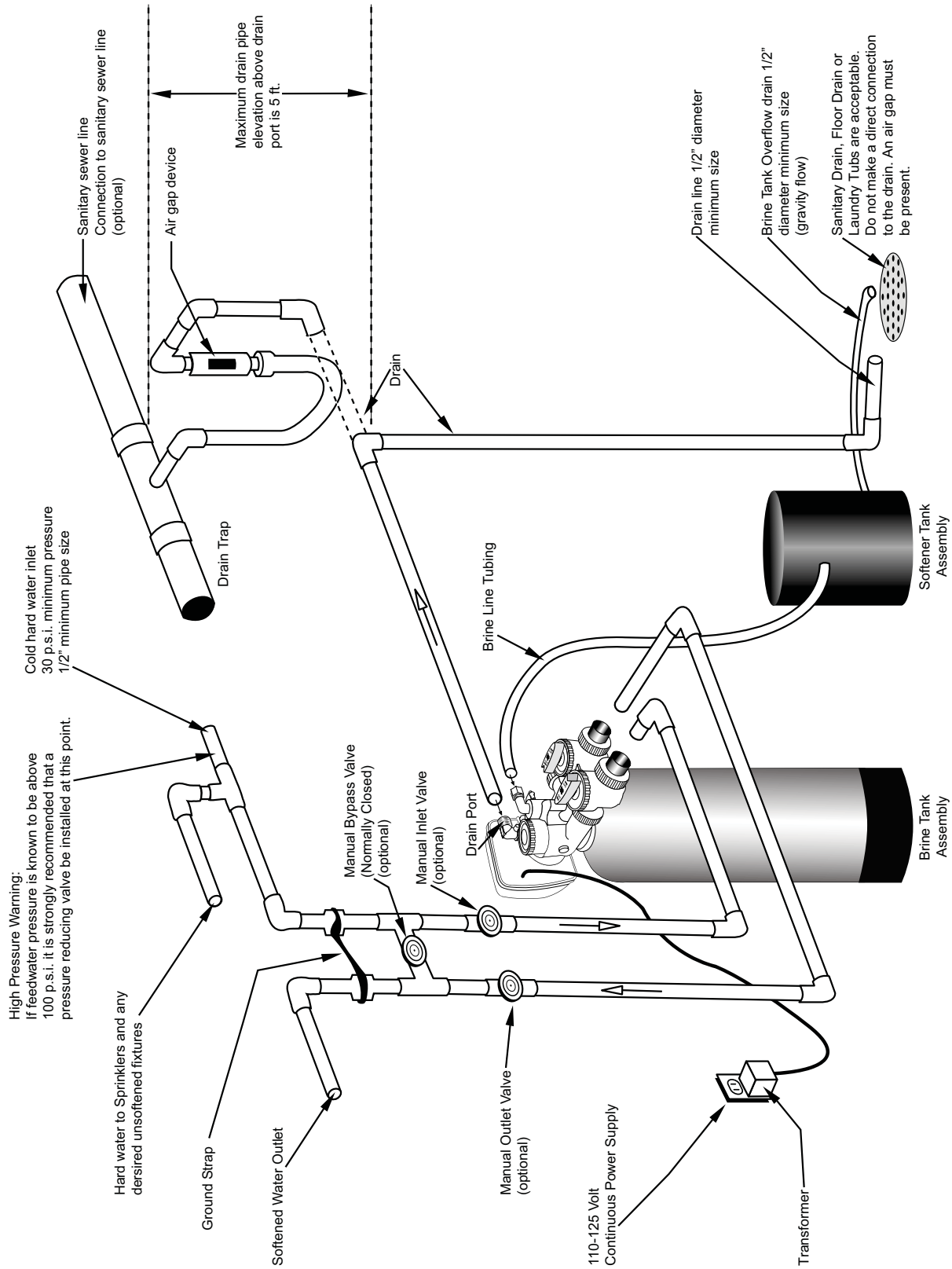

Typical Water Softener Installation

Installation Fitting Assemblies

Installation fittings connect to the control valve or the bypass valve **using nuts that only require hand tightening.** Hand tight nut connections between control valve and installation fittings, control valve and bypass valve, and bypass valve and installation fittings allow for ease serviceability. Do not use a pipe wrench to tighten nuts on installation fittings. **Hand tighten only.**

Split ring retainer design holds the nut on and allows load to be spread over the entire nut surface area reducing the chance for leakage. The split ring design, incorporated into the installation fittings allows approximately 2 degrees off axis alignment to the plumbing system. The installation fittings are designed to accommodate minor plumbing misalignments but are not designed to support the weight of a system or the plumbing.

When assembling the installation fitting package, connect the fitting to the plumbing system first and then attach the nut, split ring and o-ring. Heat from soldering or solvent cements may damage the nut, split ring or o-ring. Solder joints should be cool and solvent cements should be set before installing the nut, split ring and o-ring. Avoid getting primer and solvent cements on any part of the o-rings or split rings, bypass valve or control valve. Solvent cements and primers should be used in accordance with the manufacturer’s instructions.

Slip the nut onto the fitting first, then the split ring second and the o-ring last. hand tighten the nut. If the fitting is leaking, tightening the nut will not stop the leak. Remove the nut, remove the fitting, and check for damage or misalignment of the o-ring.

Do not use the pipe dope or other sealant on threads. Teflon tape must be used on the threads of the 1” NPT elbow and the 1/4” NPT connection and on the threads for the drain line connection. Teflon tape is not necessary on the nut connection or caps because of o-ring seals.

Do not use Vaseline, oils or other unacceptable lubricants on o-rings. A silicon lubricant may be used on black o-rings.

Bypass Valve

The bypass valve easily connects to the control valve body using nuts that only require hand tightening. Hand tighten nut connections between control valve and fittings, control valve and bypass valve, and bypass valve and installation fittings allow for easy serviceability. The split ring retainer design holds the nut on and allows load to be spread over the entire nut surface area reducing the chance for leakage. The split ring design, incorporated into the bypass, allows approximately 2 degrees off axis alignment to the plumbing system. The bypass is designed to accommodate minor plumbing misalignments but is not designed to support the weight of a system or the plumbing.

Avoid getting primer and solvent cements on any part of the o-rings or split rings, bypass valve or control valve. Do not use pipe dope or other sealant on threads. Teflon tape is not necessary on the caps because of o-ring seals.

Do not use Vaseline, oil or other unacceptable lubricants on o-rings. A silicon lubricant may be used on black o-rings.

A. GENERAL

1. Shut off all water at main supply valve.
2. **Shut off the fuel supply to water heater.**
3. Open faucets (hot and cold) nearest pump or water meter to relieve pressure and drain system.
4. Move softener into the installation position. Loosely attach all fittings to measure for bypass valve assembly (if used), or manual bypass valve.
5. Level the unit. Place shims under cabinet or brine tank as needed.
(Do Not use metal shims.)
6. Cut the **cold water** supply line as required.
7. Install the bypass valve assembly if used.

B. PLANNING INSTALLATION

1. All installation procedures must conform to local plumbing, electrical and sanitation codes and ordinances.
2. It is recommended that outside faucets for lawn service be on the hard water line, ahead of the softener, to conserve softened water, save salt and prevent lawn damage.
3. If this isn't practical, use the convenient integral bypass valve assembly during irrigation flows.
CAUTION: The inlet water temperature MUST NOT exceed 120° F.
4. Do not locate softener where ambient temperature drops below 40° F.
5. Allow space around the softener for ease of servicing.
6. The softener drain lines must never be solidly connected to the sewer line. (Always provide an air gap at the END of the drain line). Valve drain line must not be elevated over 5' from the top of the softener on well systems, and not over 8' on municipal water systems.
7. The salt storage cabinet or brine tank is a gravity drain, and this drain line must be lower than the drain fitting on the side wall of the cabinet.
8. Move the softener into position and connect to bypass assembly (if used). The integral manual bypass option is a connection which eliminates the need for a 3-valve manifold. This makes installation easier and provides a more convenient method of bypassing.
9. **IMPORTANT:** Be sure that the water inlet line is connected to the “inlet” side of the bypass valve or to the inlet fitting. (Bypass valve both inlet/outlet fittings are marked.) If water lines are reverse, (inlet/outlet) resin may be forced from the water softener into the household plumbing system. If this occurs, household plumbing system must be flushed clean.

C. CONNECT ALL FITTINGS (refer to previous page)

CAUTION: Care must be used when working with copper tubing. Do not allow the flame from torch to contact any portion of the Valve assembly.

1. Attach 1/2” drain line to drain elbow with insert and nut. Use optional 3/4” drain fittings if drain run exceeds 25 ft.
2. Do not elevate the drain line over 5' above the top of the valve (8' on municipal systems) or to exceed 25' in length at either height.

CAUTION: An air gap must be provided upon sewer entry. (Conform to local plumbing and sanitation codes and ordinances).

3. The salt storage cabinet or brine tank provides an overflow. Attach 1/2” ID flexible plastic tubing to the overflow fitting and direct it to the drain. **DO NOT** connect to the main drain line. Use a separate gravity flow line.

D. PRESSURE TEST THE INSTALLATION

The plumbing system can now be checked for any possible leaks

1. Put the unit into backwash. To do this, push and hold the REGEN button for 3-5 seconds. When the Valve stops cycling, unplug the unit. With water supply off, put the bypass into the service position.
2. Open water supply line valve very slowly. Water should escape slowly from the drain line. If water enters too quickly, resin may be lost to the drain.
3. When all of the air has been purged from the mineral tank (water flows steadily from the drain) open the main supply valve fully.
4. Allow water to run to drain until clear. CHECK FOR LEAKS!
5. Plug the unit back in.
6. Manually step the unit through the remaining steps, stopping at the fill cycle (to do this, push the REGEN button. The unit will say Brine on the screen). Once the piston has stopped moving, push the REGEN button again to the next cycle. Continue until Fill appears on the screen. The unit will now fill the brine tank to the appropriate level. (This sequence is for softeners with post fill brine)
7. Allow control to return to the home position.
8. Check for leaks!
9. Make sure the power cord is plugged into a properly grounded wall receptacle.

E. MANUAL REGENERATION

The user can initiate manual regeneration. The user has the option to request a manual regeneration at the delayed regeneration time or to have the regeneration occur immediately:

1. Pressing and releasing the REGEN button. “Regen Today” will flash on the display and the regeneration will occur at the delayed regeneration time. The user can cancel the request by pressing and releasing the REGEN button. This method of manually initiating regeneration is not allowed when the system is set to immediately regenerate when the gallon capacity reaches zero.
2. Pressing and holding the REGEN button for approximately 3 seconds will immediately start the regeneration. The user cannot cancel this request.

NOTE: Program Timer “Lockout” Feature

The Program Timer is initially set to allow access to all Programming, Diagnostic and History screens

The Installer can limit access to (lockout) most screens by activating the Lockout Feature.

Activating “Lockout” allows the user to view and change only Water Hardness, Days Override, Time of Regeneration and Time of day.

Activate “Lockout” Feature: Press then NEXT then then SET CLOCK in sequence. LOC will briefly appear in the display.

De-activate “Lockout” Feature: Press then NEXT then then SET CLOCK. UNLOC will briefly appear in the display.

When in operation normal user displays such as time of day, gallons remaining or days remaining before regeneration are shown. When stepping through a procedure if no buttons are pressed within five minutes the display returns to a normal user display. Any changes made prior to the five minute time out are incorporated. The one exception is current flow rate display under the diagnostic procedure. The current flow rate display has a 30 minute time out feature.

SUPPLEMENTAL INSTRUCTIONS COMBINATION IRON FILTER AND WATER SOFTENER

Congratulations on purchasing the most modern water treatment device available in the market. Modern in that water and regeneration chemicals are both used sparingly. Modern because total treatment of your water is accomplished with one, not two or three, pieces of equipment. Please take a few moments to read this brochure so that you fully understand the equipment.

1. PRINCIPLE OF OPERATION

- First Stage** - A special fine mesh/high kinetic resin is used. It removes all hardness (up to 100 gpg) and all ferrous (clear water) iron. About 90% of ferric (red water) iron is also removed in this step.
- Second Stage** - The first stage section is supported on a layer of scientifically graded inert filter media. 5 micron filtration is achieved which removes the balance of the ferric (red water) iron.
- Distribution** - The exclusive resin scrubber distributor keeps the resin clean and also provides for a low pressure drop at high flow rates.
- Contaminant** - Special tanks are selected so that there is no porosity or hiding spots for iron or other stain producing materials.

2. FREQUENCY OF REGENERATION

Follow the existing information in the booklet provided. To figure compensated hardness, use the following schedule:

- 0 - 10 PPM Iron - Hardness + 2 x Iron = Compensated Hardness
11 - 25 PPM Iron - Hardness + 2-1/2 x Iron = Compensated Hardness

3. LIMITATION

- Hardness - 100 U.S. grains/gallon
- Iron - Total of ferrous and ferric (clear and red water) iron up to 25 ppm.
- Organic Iron/Iron Bacteria - This is a common situation caused by a variety of bacteria (mostly non-harmful) that get into the well during initial drilling or repairs. 99% of the iron bacteria problems can be cured by following the procedure for chlorination of wells (Form 9-113-R2) which is attached.
- Colloidal Iron - Some extremely small (colloidal size) particles of iron can get thru the combination unit. If observed (this happens in less than 1% of applications), a 5 micron filter (2" x 20") on the unit outlet will solve the problem.

4. NORMAL CARE

This combination unit does a tremendous amount of work in a household. As an example, if a family of five (5) were on 50 grain water and had 10 ppg of iron, the unit would remove 650 lbs. of limestone and 8 lbs. of iron annually. At full rated capacity, it would remove 1,300 lbs. of limestone and 16 lbs. of iron. KEEP THE UNIT CLEAN. Use a salt with a cleaning additive or add 2-4 ounces of resin cleaner monthly.

PROCEDURE FOR CHLORINATION OF WELLS

Problems of iron bacteria, organic growths, algae, and their associated tastes and odors, can often be eliminated by a complete chlorination of the well and distribution piping. (See exceptions under "NOTE" below.)

Iron bacteria, while harmless, utilizes iron in water for their growth and in so doing surround themselves with relatively large, slimy, masses of iron. They attach themselves and grow on all surfaces in contact with the water. Pressure tanks, storage tanks, softeners, or filters, offer excellent breeding places. They can be completely destroyed in most cases by thoroughly chlorinating the well and complete piping system.

The method commonly used to chlorinate household wells is as follows:

1. Flush pressure tank to remove all loose sedimentary material.
2. Mix 2 gallons of household bleach and 4 ounces of soluble food grade Polyphosphate (MCC-505) in approximately 5 gallons of water.
3. Remove the top well casing seal and pour entire contents into well.
4. Connect a hose to any outside faucet and insert the discharge end of the hose into the well casing.
5. Open the faucet and allow the water to circulate for about 15 minutes.
6. While the water is circulating, open each hot and cold water tap until a chlorine odor can be detected.

NOTE: It would be well at this point to loosen the top spud of the pressure tank so that the entire tank will fill with chlorine solution. The tank can later be drained and recharged with air.

7. Pour 1 more gallon of undiluted bleach into the well casing and continue to circulate for an additional 15 minutes.
8. After the circulating period, the system should be shut down and allowed to remain quiet for at least 4 hours, preferably overnight. Do not use water, except for toilets, until the system has been thoroughly flushed.
9. Flush the well first by removing the hose from the well casing and opening the hose faucet until the discharge is free of chlorine. Then open each hot and cold tap and allow to run until water is free of chlorine.

NOTE: The above chlorination procedure is not effective for removing all of the rotten egg odor of sulfur waters, or for killing bacteria where septic drainage, etc. has contaminated the underground water supply.

In these cases, or when the well is such that it cannot be chlorinated, continuous chlorination with a chemical solution pump and filtration through an activated carbon filter is recommended. In severe cases of pollution, relocation of the well is the best alternative.

Control Valve Function and Cycles of Operation

This glass filled Noryl¹ fully automatic control valve is designed as the primary control center to direct and regulate all cycles of a water softener or filter. When the control valve is set up as a softener, the control valve can be set to perform down flow or up flow regeneration with the proper piston. When the control valve is set up as a filter, the control valve can be set to perform down flow regeneration or simply backwash. The control valve can be set to regenerate on demand (consumption of a predetermined amount of water) and/or as a time clock (passage of a particular number of days). The control valve can be set so that the softener can meet the Water Quality Association (WQA) or NSF International efficiency rating.

The control valve is compatible with a variety of regenerants and resin cleaners. The control valve is capable of routing the flow of water in the necessary paths to regenerate or backwash water treatment systems. The injector regulates the flow of brine or other regenerants. The control valve regulates the flow rates for backwashing, rinsing and the replenishing of treated water into a regenerant tank, when applicable.

The control valve is designed to deliver high service (27 gpm @ 15 psig) and backwash (27 gpm @ 25 psig) flow rates when the bypass has straight fittings and a 1.050” distributor. The control valve uses no traditional fasteners (e.g. screws), instead clips, threaded caps, nuts and snap type latches are used. Caps and nuts only need to be firmly hand tightened because radial seals are used. Tools required to service the valve include one small blade screwdriver, pliers and a pair of hands. Disassembly for servicing takes much less time than comparable products currently on the market. Control valve installation is made easy because the distributor tube can be cut 1/2” above to 1/2” below the top of the tank thread. The distributor tube is held in place by an o-ring seal and the control valve also has a bayonet lock feature for upper distributor baskets.

The transformer power pack comes with a 15-foot power cord and is designed for use with the control valve. The transformer power pack is for dry location use only. The control valve remembers all settings for two hours if the power goes out. After two hours, the only item that needs to be reset is the time of day; all other values are stored in the memory. The control valve does not need batteries.

Table 3 shows the order of the cycles when the valve is set up as a softener. When the control valve is used as a down flow softener, two backwashes always occur. When the control valve is used as an up flow softener, only one backwash occurs after brining. The installer has the option of having the regenerant refill after the rinse cycle or have the regenerant prefill before regeneration. If the installer chooses to have the regenerant prefill before regeneration, the prefill starts two hours before the regeneration time set. During the 2-hour period in which the brine is being made, treated (softened) water is still available. For example: regeneration time = 2:00 A.M., prefill option selected, downflow softener. Fill occurs at 12:00 A.M., start of backwash cycle occurs at 2:00 A.M.

1 - Noryl is a trademark of General Electric

Table 3 Regeneration Cycles
1st Cycle: Backwash Normal
2nd Cycle: Regenerate
3rd Cycle: Backwash Normal
5th Cycle: Rinse
6th Cycle: Fill

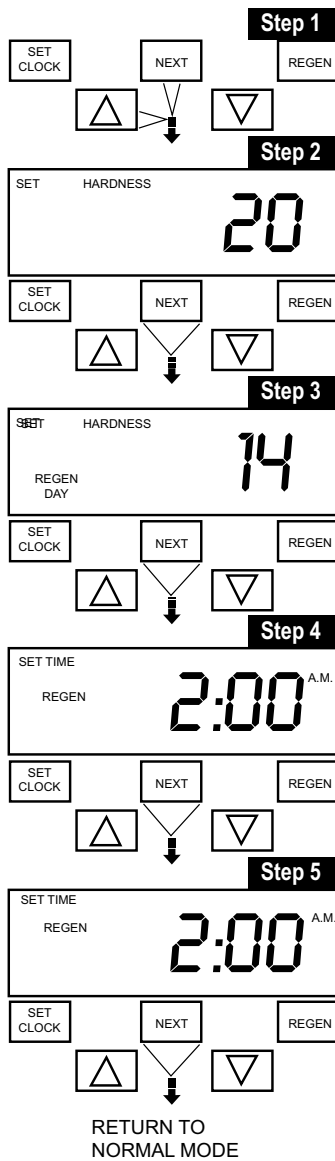

Installer Displays/Settings

STEP 1 - Press NEXT and simultaneously for 3 seconds.

STEP 2 - Hardness: Set the amount of hardness in grains of hardness as calcium carbonate per gallon using the or buttons. Value ranges from 1 to 150 in 1 grain increments. Note the grains per gallon can be increased if soluble iron needs to be reduced. This display will show “-nA-” if “FILTER” is selected or if ‘AUTO’ is not selected. Press NEXT to go to step 3. Press REGEN to exit Installer Displays/Settings.

STEP 3 - Day Override: When gallon capacity is set to off, set the number of days between regenerations. When gallon capacity is set to AUTO or to a number, set the maximum number of days between regenerations. If value set to “oFF” regeneration initiation is based solely on gallons used. If value is set as a number (allowable range from 1 to 28) a regeneration initiation will be called for on that day even if sufficient number of gallons were not used to call for a regeneration. Set Day Override using or buttons:

- number of days between regeneration (1 to 28); or
- “oFF”

Press NEXT to go to step 4. Press REGEN to return to previous step.

STEP 4 - Next Regeneration Time (hour): Set the hour of day for regeneration using or buttons. AM/PM toggles after 12. The default time is 2:00 a.m. This display will show “REGEN on 0 GAL” if “on 0” is selected in by the installer. Press NEXT to go to Step 5. Press REGEN to return to previous step.

STEP 5 - Next Regeneration Time (minutes): Set the minutes of day for regeneration using or buttons. This display will not be shown if “on 0” is selected by the installer (2 a.m. is the factory setting). Press NEXT to exit Installer Displays/Settings. Press REGEN to return to previous step. To initiate a manual regeneration immediately, press and hold the “REGEN” button for three seconds. The system will begin to regenerate immediately. The control valve may be stepped through the various regeneration cycles by pressing the “REGEN” button.

General Operation

When the system is operating one of two displays will be shown. Pressing NEXT will alternate between the displays. One of the displays is always the current time of day which has to be set (see pg.9). Capacity remaining is the number of gallons that will be treated before the system goes through a regeneration cycle. The user can scroll between the displays as desired.

If the system has called for a regeneration that will occur at the preset time of regeneration, the words REGEN TODAY will appear on the display.

When water is being treated (i.e. water is flowing through the system) the word “Softening” or “Filtering” flashes on the display.

User Displays/Settings

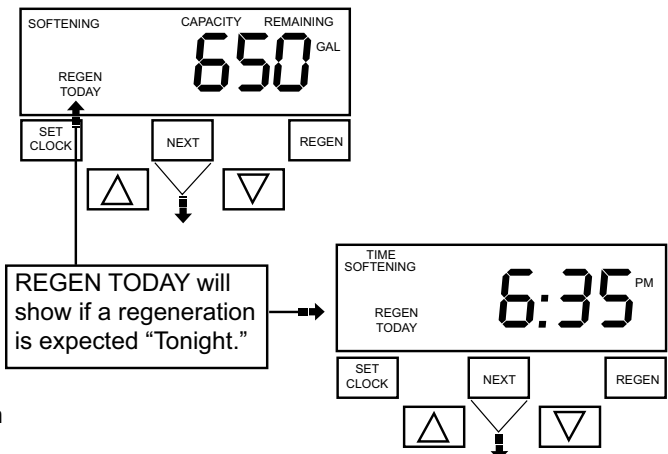

Regeneration Mode

Typically a system is set to regenerate at a time of low water usage. An example of a time with low water usage is when a household is asleep. If there is a demand for water when the system is regenerating, untreated water will be used.

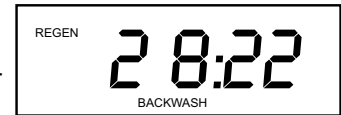

When the system begins to regenerate, the display will change to include information about the step of the regeneration process and the time remaining for that step to be completed. The system runs through the steps automatically and will reset itself to provide treated water when the regeneration has been completed.

Manual Regeneration

Sometimes there is a need to regenerate the system, sooner than when the system calls for it, usually referred to as manual regeneration. There may be a period of heavy water usage because of guests or a heavy laundry day.

REGEN TODAY will show if a regeneration is expected “Tonight.”

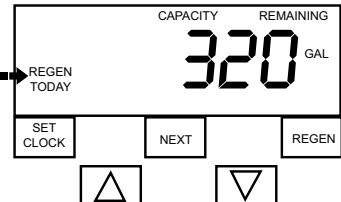

To initiate a manual regeneration at the preset delayed regeneration time, press and release “REGEN”. The words “REGEN TODAY” will flash on the display to indicate that the system will regenerate at the preset delayed regeneration time. If you pressed the “REGEN” button in error, pressing the button again will cancel the request. Note: If the regeneration time option is set to “on 0” there is no set delayed regeneration time so “REGEN TODAY” will not activate if “REGEN” button is pressed.

To initiate a manual regeneration immediately, press and hold the “REGEN” button for three seconds. The system will begin to regenerate immediately. The request cannot be cancelled.

Note: For softeners, if brine tank does not contain salt, fill with salt and wait at least two hours before regenerating.

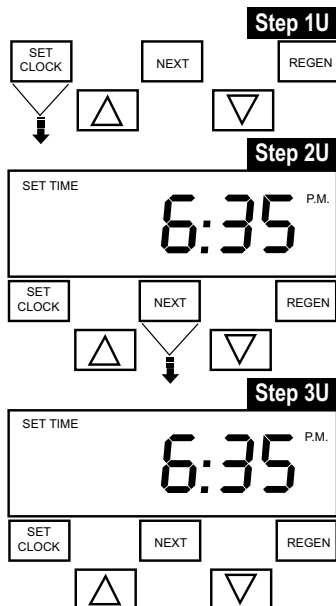

Set Time of Day

The user can also set the time of day. Time of day should only need to be set after extended power outages or when daylight saving time begins or ends and at the time of start-up. If an extended power outage occurs, the time of day will flash on and off which indicates the time of day should be reset.

STEP 1U - press SET CLOCK.

STEP 2U - Current Time (hour): Set the hour of the day using or buttons. AM/PM toggles after 12. Press NEXT to go to step 3U.

STEP 3U - Current Time (minutes): Set the minutes of the day using or buttons. Press NEXT to exit Set Clock. Press REGEN to return to previous step.

Power Loss

If the power goes out for **less than two hours**, the system will automatically reset itself. If an extended power outage occurs, the time of day will flash on and off which indicates the time of day should be reset. The system will retain the other information entered by the installer.

Error Message

If the word “ERROR” and a number are alternately flashing on the display contact the Installer for help. This indicates that the valve was not able to function properly. Refer to “Troubleshooting” for “ERROR RESET” procedure.



FLOW DIAGRAMS

flow diagram...service

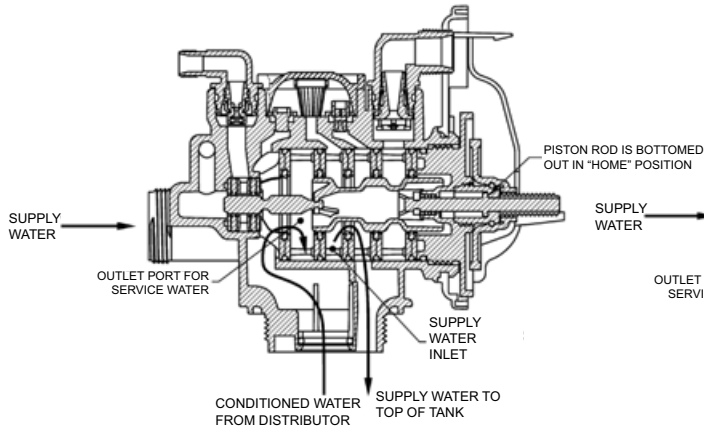

flow diagram...backwash

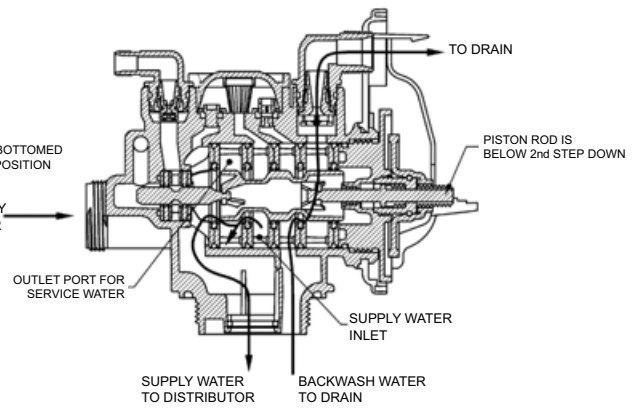

flow diagram...downflow brine

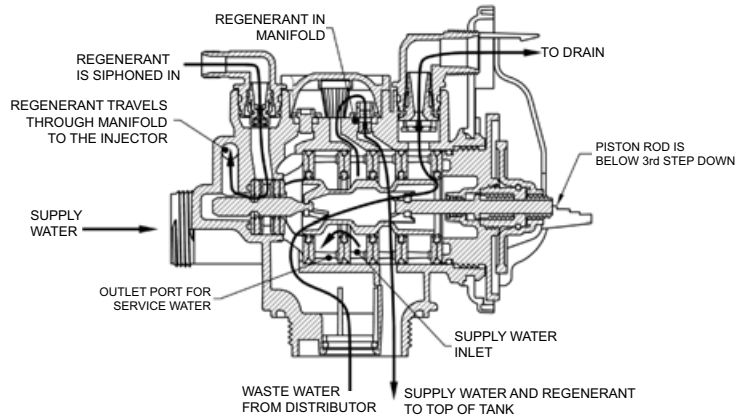

flow diagram...rinse

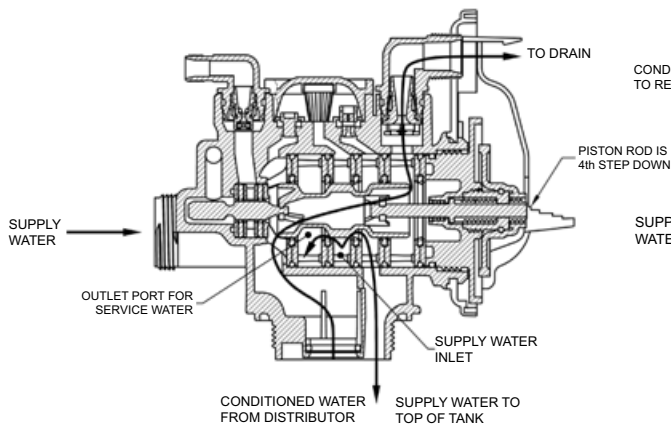

flow diagram...fill

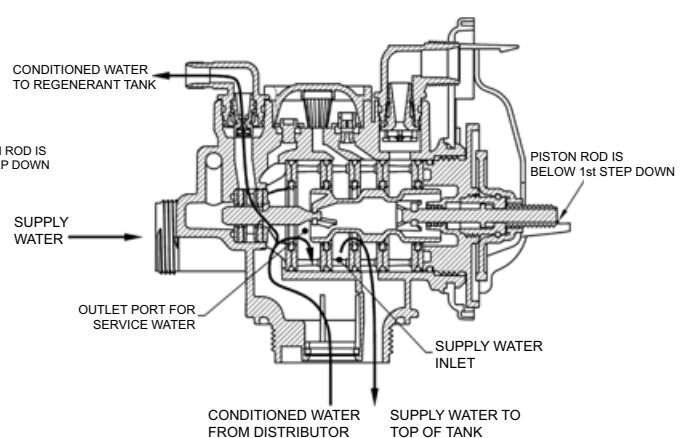

Bypass Valve

The bypass valve is typically used to isolate the control valve from the plumbing system’s water pressure in order to perform control valve repairs or maintenance. The WS1 bypass valve is particularly unique in the water treatment industry due to its versatility and state of the art design features. The 1” full flow bypass valve incorporates four positions including a diagnostic position that allows service personal to work on a pressurized system while still providing untreated bypass water to the facility or residence. Its completely non-metallic, all plastic, design allows for easy access and serviceability without the need for tools.

The bypass body and rotors are glass filled Noryl and the nuts and caps are glass filled polypropylene. All seals are self-lubricating EPDM to help prevent valve seizing after long periods of non-use. Internal o-rings can easily be replaced if service is required.

The bypass consists of two interchangeable plug valves that are operated independently by red arrow shaped handles. The handles identify the flow direction of the water. The plug valves enable the bypass valve to operate in four positions.

Figure 1
NORMAL OPERATION

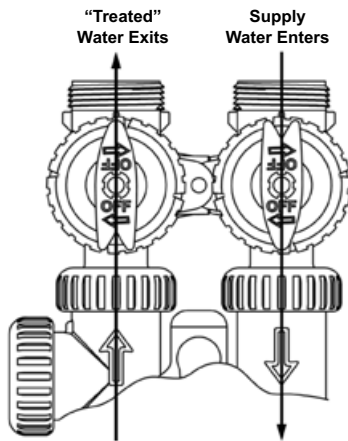

Normal Operation:

The inlet and outlet handles point in the direction of flow indicated by the engraved arrows on the control valve. Water flows through the control valve during normal operation and this position also allows the control valve to isolate the media bed during the regeneration cycle.

Figure 2
BYPASS OPERATION

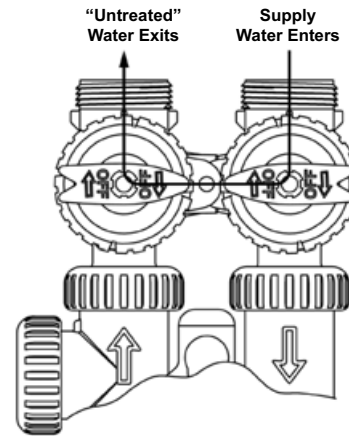

Bypass:

The inlet and outlet handles point to the center of the bypass, the control valve is isolated from the water pressure contained in the plumbing system. Untreated water is supplied to the plumbing system.

Figure 3
DIAGNOSTIC MODE

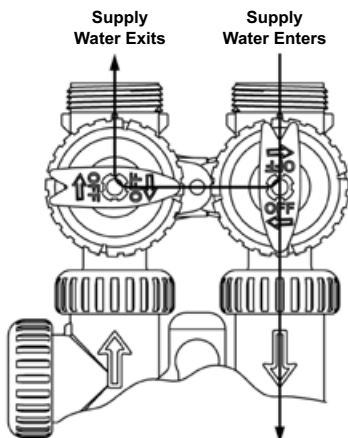

Diagnostic:

The inlet handle points in the direction of flow and the outlet handle points to the center of bypass valve, system water pressure is allowed to the control valve and the plumbing system while not allowing water to exit from the control valve to the plumbing.

Figure 4
SHUT OFF MODE

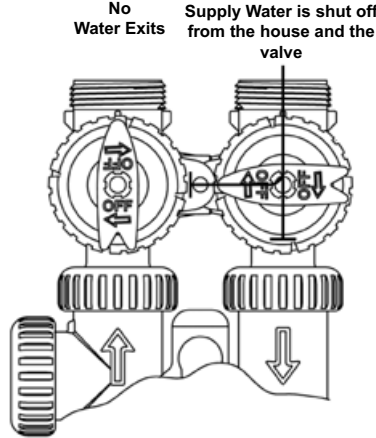

Shut Off:

The inlet handle points to the center of the bypass valve and the outlet handle points in the direction of flow, the water is shut off to the plumbing system. If water is available on the outlet side of the softener it is an indication of water bypass around the system (i.e. a plumbing connection somewhere in the building bypasses the system).

**Drive Cap Assembly, Downflow Piston,
Regenerant Piston and Spacer Stack Assembly
& Front Cover and Drive Assembly**

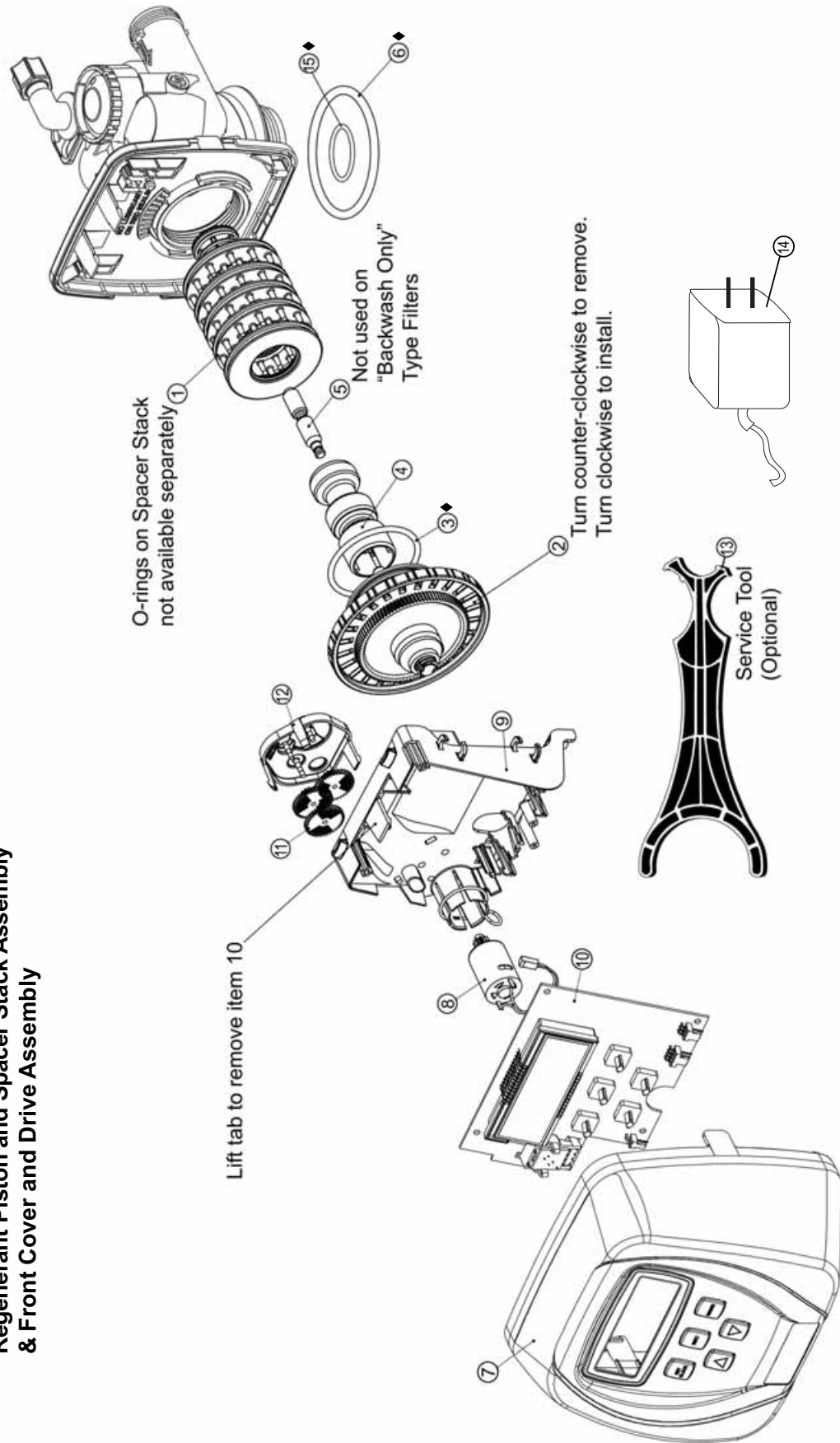

Drive Cap Assembly, Downflow Piston, Upflow Piston, Regenerant Piston and Spacer Stack Assembly

Item No.	Part No.	Description	Quantity
1	A2466034	*Spacer Stack Assembly w/o o-rings	1
2	A2080077	Drive Cap Assembly	1
◆3	A2077180	O-Ring 228 (use Valve O-ring Kit)	1
▲4	A2309040	Piston Downflow Assembly	1
⊗5	A2438033	Regenerant Piston	1
◆6	A2077181	O-Ring 337 (use Valve O-ring Kit)	1
◆15	A2077178	O-Ring 215 (use Valve O-ring Kit)	1

▲ Item #4 identified with “DN” code.

⊗ Item #5 not used with Backwash Only filter applications.

◆ See page 20 for Valve O-ring Kit.

Front Cover and Drive Assembly

Item No.	Part No.	Description	Quantity
7	A2103134	Front Cover ASSY	1
8	A2085050	Motor	1
9	A2328046	Drive Bracket & Spring Clip	1
10	A2341016	PC Board	1
11	A2393046	Drive Gear 12 x 36	3
12	A2103132	Drive Gear Cover	1
13	A2491086	Service Tool	1
14	A2242054	Transformer 110V - 12V	1

**Injector Cap, Injector Screen, Injector, Plug ,
O-Ring, Refill and Refill Port Plug,
& Drain Line - 3/4”**

◆ Part of Kit, O-ring (Item #51, pg. 20)

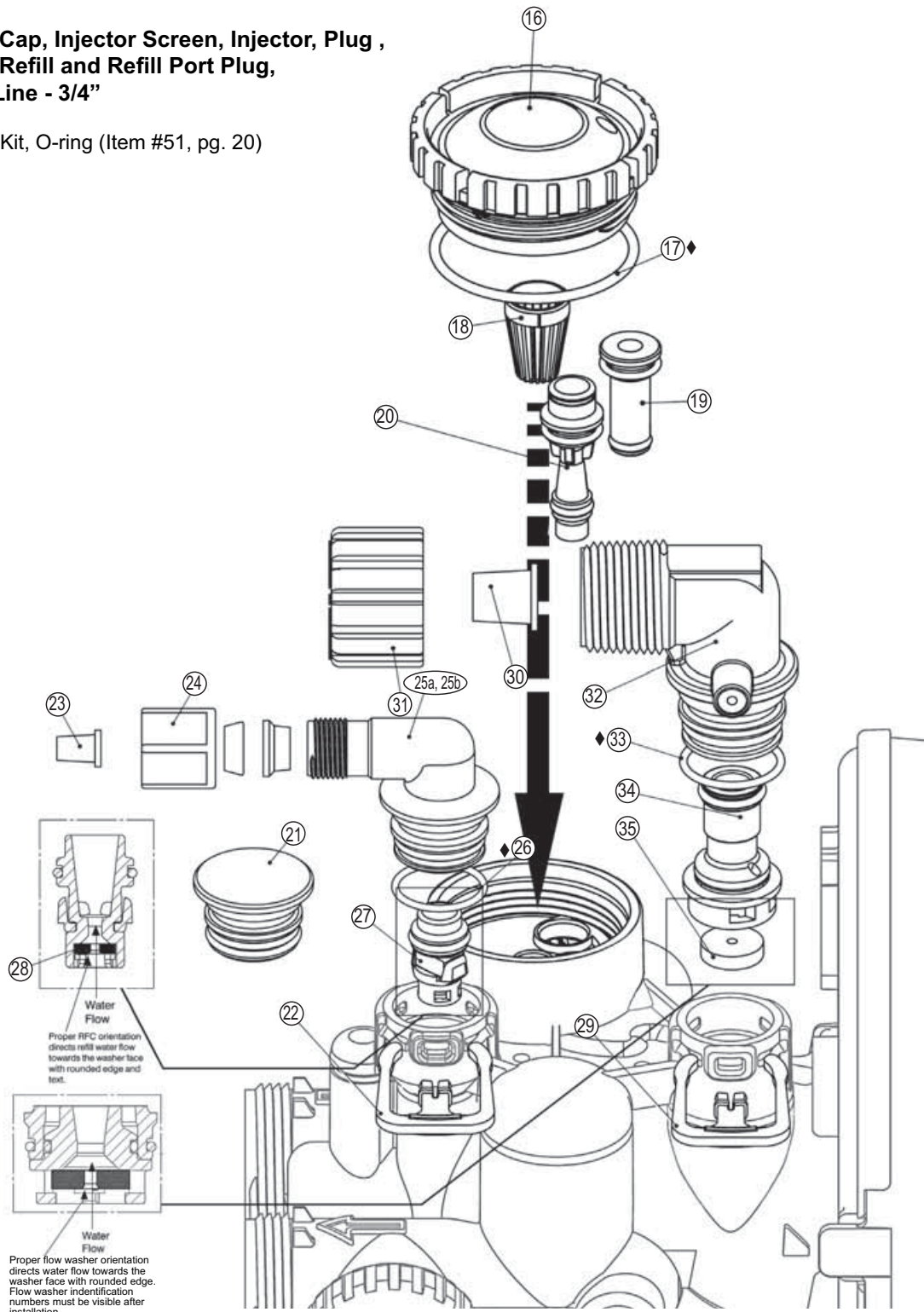

Injector Cap, Injector Screen, Injector, Plug and O-Ring

Item No.	Part No.	Description		Quantity
16	A2080079	Injector Cap		1
◆17	A2077182	O-Ring 135 (Use Valve O-ring Kit)		1
18		Injector Screen		1
19	A2079059	Injector Assembly Z Plug	See note	1
20	A2079060	Injector Assembly A Black		
	A2079048	Injector Assembly B Brown		
	A2079046	Injector Assembly C Violet		
	A2079045	Injector Assembly D Red - CLSM30		
	A2079049	Injector Assembly E White		1
	A2079047	Injector Assembly F Blue		
	A2079050	Injector Assembly G Yellow		
	A2079055	Injector Assembly H Green		
	A2079062	Injector Assembly I Orange		
	A2079063	Injector Assembly J Light Blue		
A2079064	Injector Assembly K Light Green			

*The injector plug and the injector each contain one 011 (lower) and 013 (upper) o-ring.

Note: For downflow brine, injector is located in the down hole and injector plug in the up hole.
For a filter that only backwashes injector plugs are located in both holes.

Refill and Refill Port Plug

Drawing No.	Order No.	Description	Quantity
21	A2287059	Refill Port Plug Assembly	This part is required for backwash only systems
22	A2411015	Elbow Locking Clip	1
23	A2409016	Polytube insert 3/8	1
24	A2095071	Nut 3/8	1
25a	A2080078	Elbow Cap 3/8	(use w/ 3/8" tubing) 1
25b	A2129100	Elbow 1/2" with nut and insert	(use w/ 1/2" tubing) Option
◆26	A2077179	O-Ring 019 (Use Valve O-ring Kit)	1
27	A2104033	RFC Retainer Assembly*	1
28		RFC Brine Refill Flow Washer	1

*Assembly includes RFC.

Drain Line - 3/4"

Drawing No.	Order No.	Description	Quantity
29	A2411015	Elbow Locking Clip	1
30	A2409013	Polytube insert 5/8	Option
31	A2095065	Nut 3/4 Drain Elbow	Option
32	A2099056	Drain Elbow 3/4 Male Assembly	1
◆33	A2077179	O-Ring 019 (Use Valve O-ring Kit)	1
34	A2104034	Drain Flow Washer Retainer Assembly	1
35	A2253114	Drain Flow Washer 0.7 gpm for 3/4	One DLFC must be used if 3/4 fitting is used
	A2253099	Drain Flow Washer 1.0 gpm for 3/4	
	A2253084	Drain Flow Washer 1.3 gpm for 3/4	
	A2253083	Drain Flow Washer 1.7 gpm for 3/4	
	A2253081	Drain Flow Washer 2.2 gpm for 3/4 -CLSM30	
	A2253082	Drain Flow Washer 2.7 gpm for 3/4	
	A2253085	Drain Flow Washer 3.2 gpm for 3/4	
	A2253086	Drain Flow Washer 4.2 gpm for 3/4	
A2253087	Drain Flow Washer 5.3 gpm for 3/4		

"C" Series

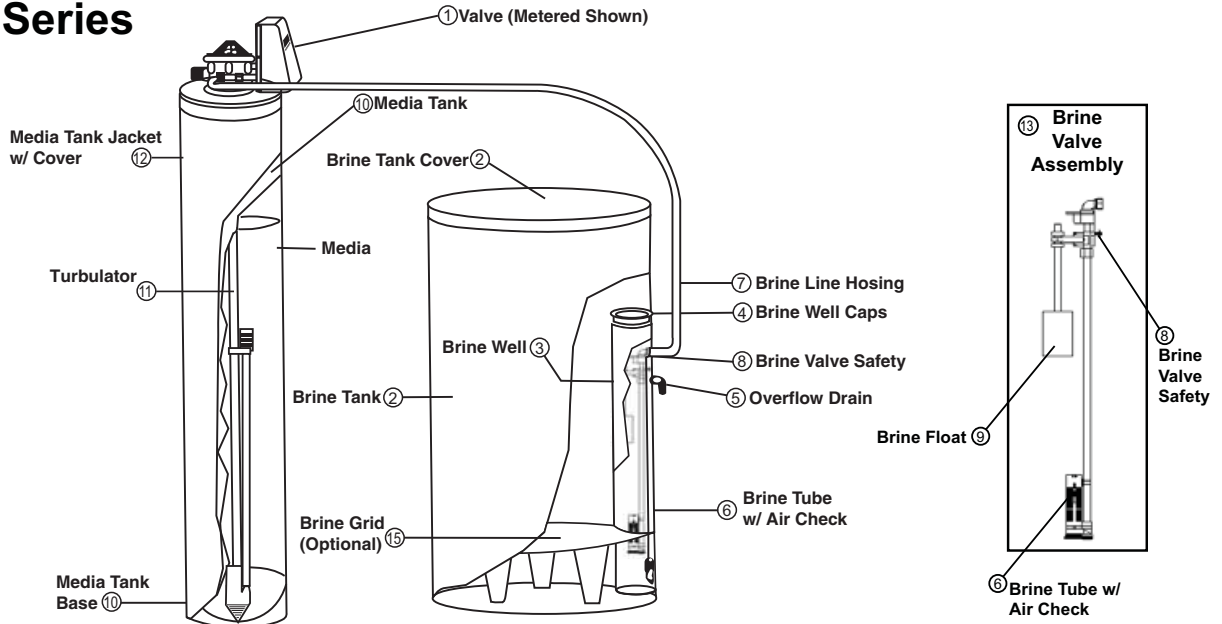

Parts Listing

Part Number	No.	Description
B1074---	1	Valve Metered (Complete - Specify Model)
A2042062	2	Brine Tank w/ Cover Complete
A2071005	3	Brine Well
A2072003	4	Brine Well Cap
A2250003	5	Overflow Elbow
A2118010	6	Brine Tube w/ Air Check
B1020001	7	Brine Line Hose w/ Inserts
A2005058	8	Brine Valve Safety
A2107022	9	Brine Float
A2121047-	--	Media (Specify Model)
B1026	11	Turbulator - Specify Model
B1024---	12	Media Tank Jacket w/ cover - Optional
B1179005	13	* Brine Valve Assembly - Complete - Includes #'s 6, 8, & 9
A2284017	15	*Grid (Optional)

Water Meter and Meter Plug

Item No.	Part No.	Description	Quantity
36	A2095069	Nut 1" Quick Connect	1
*37	A2360039	Meter Assembly	1
38	A2100027	Turbine Assembly	1
39	A2077178	O-Ring 215 (Use Valve O-ring Kit)	1
40	A2287077	Meter Plug Assembly (Time clock option)	1

*Item #37 includes Items #38 & #39.

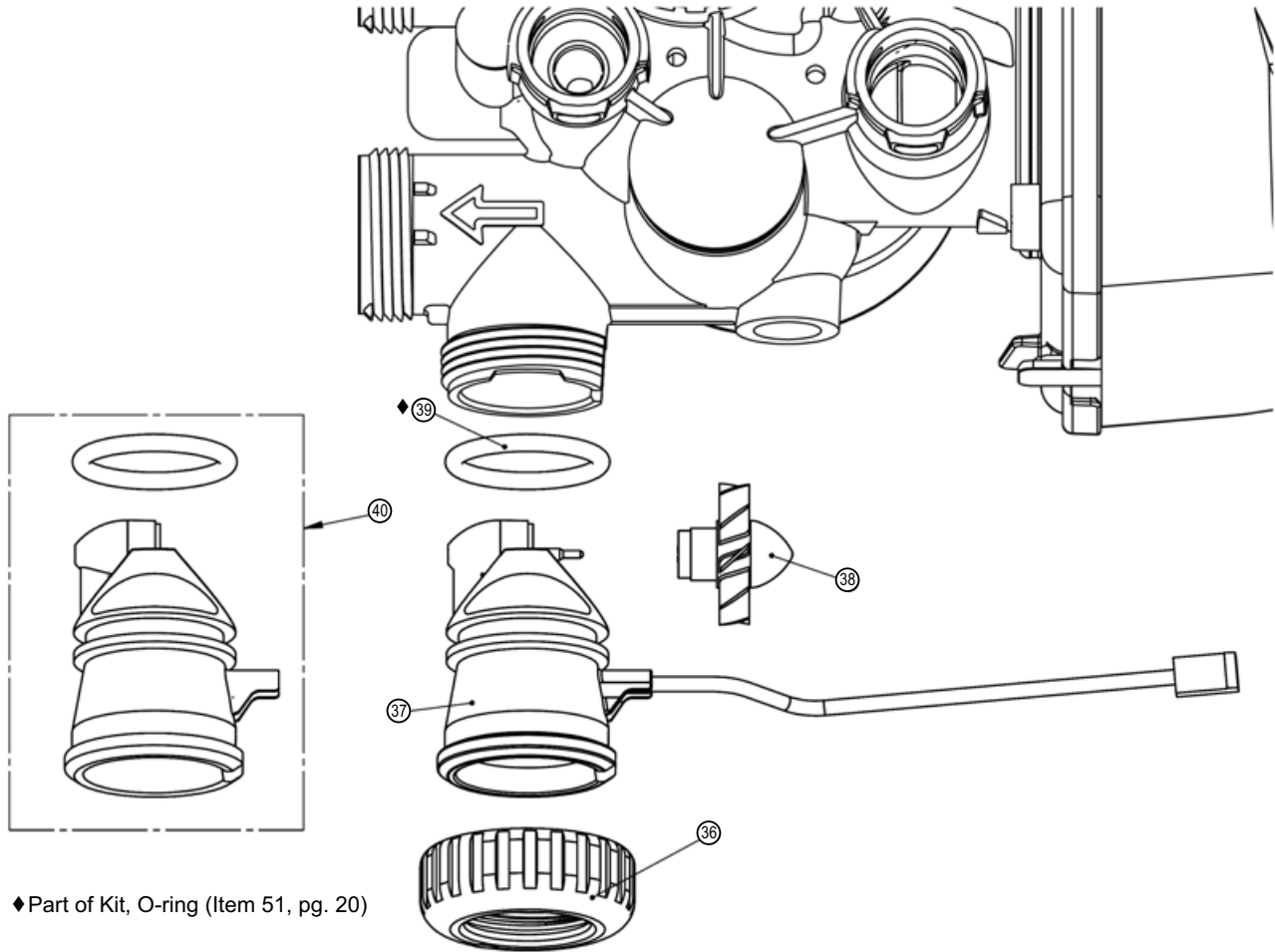

Item No.	Part No.	Description	Quantity
41	A2095069	Nut 1" Quick Connect	2
42	A2453012	Split Ring	2
●43	A2077178	O-Ring 215 (Kit available - see Item #10)	2
44	A2607004	Bypass 1" Rotor	2
45	A2080090	Bypass Cap	2
46	A2395009	Bypass Handle	2
47	A2104036	Bypass Rotor Seal Retainer	2
●48	A2077182	O-Ring 135 (use Bypass Valve Kit)	2
●49	A2077223	O-Ring 112 (use Bypass Valve Kit)	2
●50	A2077224	O-Ring 214 (use Bypass Valve Kit)	2

●Part of Kit, O-ring By-Pass(Item 52)

◆ Valve O-ring Kit

51	B1213022	KIT O-ring (contains 1 each of 3, 6, 15, 17, 26, & 33)	1 per valve
----	----------	--	-------------

● Bypass Valve O-ring Kit

52	B1213021	KIT O-ring Bypass (Incl. 2 ea. of items 43,48,49,& 50)	1 per valve
----	----------	--	-------------

(Not Shown) Description Bypass Vertical Adapter Assembly

Complete Assembly

53	A23540231	Bypass Valve Complete / Less Connectors	1 per valve
----	-----------	---	-------------

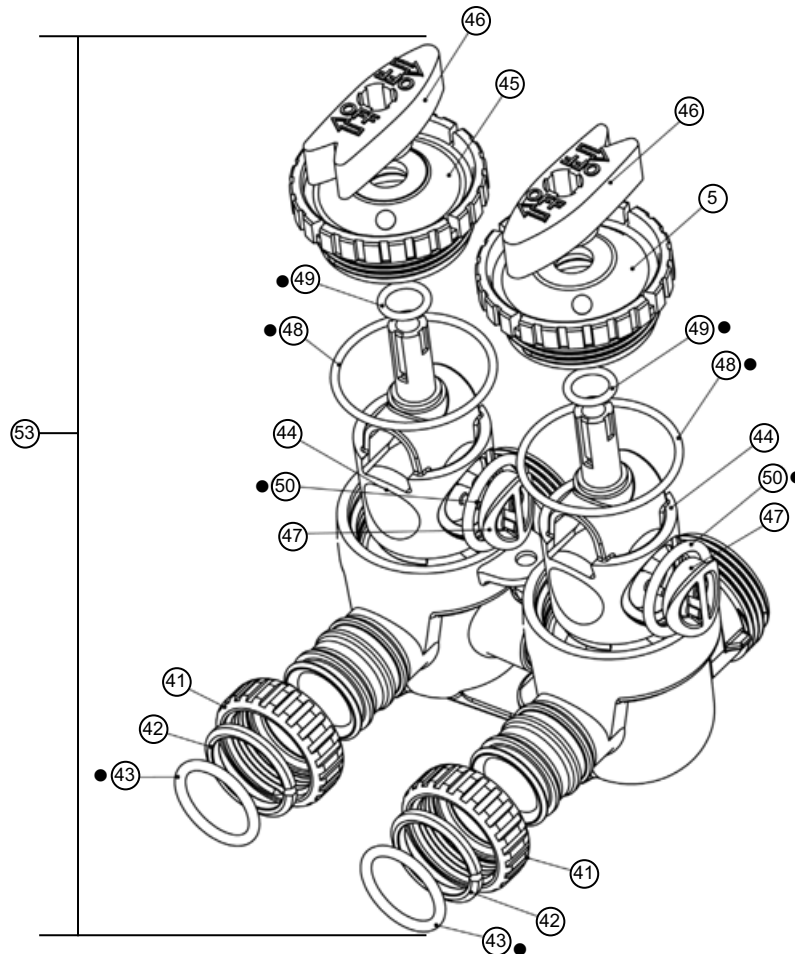

Order No: **A2129080 (Standard)**
 Description: **Fitting 1” PVC Male NPT Elbow Assembly**

Drawing No.	Order No.	Description	Quantity
1	A2095069	Nut 1” Quick Connect	2
2	A2453012	Split Ring	2
3	A2077178	O-Ring 215	2
4	A2129101	Fitting 1”PVC MaleNPT Elbow	2

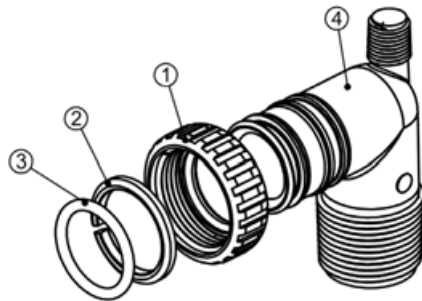

Order No: **A2099054 (Optional)**
 Description: **Fitting 3/4” & 1” PVC Solvent 90° Asy**

Drawing No.	Order No.	Description	Quantity
1	A2095069	Nut 1” Quick Connect	2
2	A2453012	Split Ring	2
3	A2077178	O-Ring 215	2
4	A2569008	Fitting 3/4&1 PVC Solvent 90	2

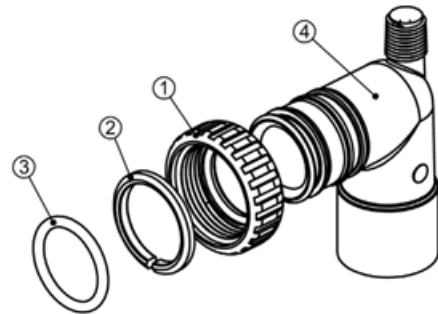

Order No: **A2435068 (Optimal)**
 Description: **Fitting 1” Brass Sweat Assembly**

Drawing No.	Order No.	Description	Quantity
1	A2095069	Nut 1” Quick Connect	2
2	A2453012	Split Ring	2
3	A2077178	O-Ring 215	2
4	A2569006	Fitting 1” Brass Sweat	2

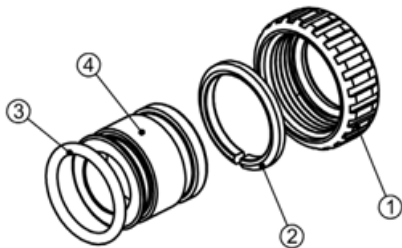

Order No: **A2435072 (Optional)**
 Description: **Fitting 3/4” Brass Sweat Assembly**

Drawing No.	Order No.	Description	Quantity
1	A2095069	Nut 1” Quick Connect	2
2	A2453012	Split Ring	2
3	A2077178	O-Ring 215	2
4	A2569007	Fitting 3/4” Brass Sweat	2

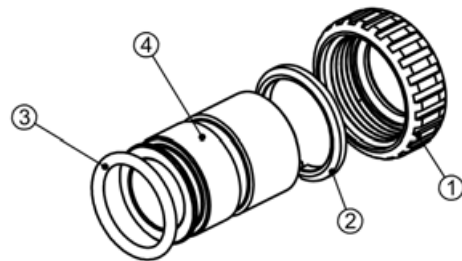

**Table 15
Troubleshooting Procedures**

Problem	Possible Cause	Solution
1. Timer does not display time of day	a. Transformer unplugged	a. Connect power
	b. No electric power at outlet	b. Repair outlet or use working outlet
	c. Defective transformer	c. Replace transformer
	d. Defective PC board	d. Replace PC board
2. Timer does not display correct time of day	a. Switched outlet	a. Use uninterrupted outlet
	b. Power outage	b. Reset time of day
	c. Defective PC board	c. Replace PC board
3. No softening/filtering display when water is flowing	a. Bypass valve in bypass position	a. Put bypass valve in service position
	b. Meter connection disconnected	b. Connect meter to PC board
	c. Restricted/stalled meter turbine	c. Remove meter and check for rotation or foreign material
	d. Defective meter	d. Replace meter
	e. Defective PC board	e. Replace PC board
4. Control valve regenerates at wrong time of day	a. Power outages	a. Reset control valve to correct time of day
	b. Time of day not set correctly	b. Reset to correct time of day (a.m./p.m.)
	c. Time of regeneration incorrect	c. Reset regeneration time (a.m./p.m.)
	d. Control valve set at “on 0” (immediate regeneration)	d. Check control valve set-up procedure regeneration time option
	e. Control valve set at NORMAL + on 0	e. Check control. valve set-up procedure regeneration time option
5.ERROR followed by code number 1001 Error Code - Unable to recognize start of regeneration 1002 Error Code - Unexpected stall 1003 Error Code - Motor ran to long, timed out trying to reach next cycle position 1004 Error Code - Motor ran to long, timed out trying to reach home position If other Error Codes display contact the factory ERROR Reset Procedure: 1. Correct error condition. 2. Press NEXT and REGEN simultaneously for three seconds.	a. Control valve has just been serviced	a. Press NEXT and REGEN for 3 seconds or unplug power source jack (black wire) and plug back in to reset control valve
	b. Foreign matter is lodged in control valve	b. Check piston and spacer stack assembly for foreign matter
	c. High drive forces on piston	c. Replace piston(s) and spacer stack assembly
	d. Control valve piston not in home position	d. Press NEXT and REGEN for 3 seconds or unplug power source jack (black wire) and plug back in to reset control valve
	e. Motor not inserted fully to engage pinion, motor wires broken or disconnected, motor failure	e. Check motor and wiring. Replace motor if necessary
	f. Drive gear label dirty or damaged, missing or broken gear	f. Replace or clean drive gear(s)
	g. Drive bracket incorrectly aligned to back plate	g. Reseat drive bracket properly
	h. PC board is damaged or defective	h. Replace PC board
	i. PC board incorrectly aligned to drive bracket	i. Ensure PC board is correctly snapped on to drive bracket

Troubleshooting Procedures (continued)

Problem	Possible Cause	Solution
6. Control valve stalled in regeneration	a. Motor not operating	a. Replace motor
	b. No electric power at outlet	b. Repair outlet or use working outlet
	c. Defective transformer	c. Replace transformer
	d. Defective PC board	d. Replace PC board
	e. Broken drive gear or drive cap assembly	e. Replace drive gear or drive cap assembly
	f. Broken piston retainer	f. Replace drive cap assembly
	g. Broken main or regenerant piston	g. Replace main or regenerant piston
7. Control valve does not regenerate automatically when REGEN button is depressed and held	a. Transformer unplugged	a. Connect transformer
	b. No electric power at outlet	b. Repair outlet or use working outlet
	c. Broken drive gear or drive cap assembly	c. Replace drive gear or drive cap assembly
	d. Defective PC board	d. Replace PC board
8. Control valve does not regenerate automatically but does when REGEN button is depressed	a. By-pass valve in bypass position	a. Put control valve in service position
	b. Meter connection disconnected	b. Connect meter to PC board
	c. Restricted/stalled meter turbine	c. Remove meter and check for rotation or foreign material
	d. Defective meter	d. Replace meter
	e. Defective PC board	e. Replace PC board
	f. Set-up error	f. Check control valve set-up procedure
9. Time of day flashes on and off	a. Power has been out more than two hours, the transformer was unplugged and then plugged back into the wall outlet, the transformer plug was unplugged and then plugged back into the board or the NEXT and REGEN buttons were pressed to reset the valve.	a.. Reset the time of day

NOTES



2227 South Street
P.O. Box 044170
Racine, WI 53404-7003
Ph. (262) 681-1300
Fax (262) 681-1318
www.Marlo-Inc.com