



COPPER-FIN II[®]

**Commercial Gas
Water Heaters**

High Efficiency In A Space-Saving Design

CLICK ANYWHERE on THIS PAGE to RETURN to LOCHINVAR WATER HEATER INFORMATION at InspectApedia.com



From 400,000 to 2,070,000 Btu/hr
85% Thermal Efficiency
Less Than 30 ppm NOx Rating



**MULTI-
STACK**

Copper-Fin II® Gas Water Heaters. The Proven Performers.

Thermal Efficiency Is Higher... While Footprint And Vent Sizes Are Smaller

Lochinvar's Copper-Fin II® line of high efficiency commercial gas water heaters gives you all the advantages of lime scale-free, copper finned tube heat exchanger technology plus the benefits of a sealed combustion system. Every Copper-Fin II model offers four major advantages: higher efficiency, smaller footprint, smaller vent diameters and multiple venting options.

Our Copper-Fin II models offer dollar-stretching proportional firing that provides a measured response to the demand for heat — as much or as little as needed.

Outstanding Thermal Efficiency

Copper-Fin II water heaters offer a remarkably high 85% thermal efficiency. This means that 85¢ out of every fuel dollar goes into heating the water, dramatically reducing the operating cost of the equipment. Copper-Fin II achieves this efficiency through the combination of an advanced fan assisted combustion system and exclusive gasketless copper finned tube heat exchanger. A time tested and proven combination.

The heat energy from the combustion process is transferred to the water as it passes through the solid copper finned tube heat exchanger. The sealed combustion design of the Copper-Fin II eliminates external heat losses, this means that the energy dollars heat the water, not the surroundings. It also ensures that the jacket stays cooler, providing greater safety and requiring less clearance from combustible walls - just 1" in most cases.



Proportional Firing: Greater Savings, More Accurate Temperatures

The Copper-Fin II's proportional firing lowers your energy costs and delivers more consistent water temperatures. Multiple gas valves supply gas to the burners in stages, and multiple blower(s) maintain the proper airflow to ensure the most efficient combustion at each level of use. With digital accuracy, the built-in sequencer carefully monitors the need for heat, and as demand increases or decreases, it automatically adjusts the blower output and gas valve input.

As the demand is met, the water heater decreases output gradually, turning off gas valves and reducing combustion air in direct proportion. This allows the Copper-Fin II to maintain a constant setting. In fact,

it's accurate to within 1° Fahrenheit — a remarkable achievement for units of this capacity. And the proportional firing system features component redundancy, greatly reducing the chance for total system shutdown.

Compact Design - For Installation Ease

The Copper-Fin II is compact enough to fit through standard 36" doorways with ease. Even our 2 million Btu/hr model is only 33-1/2" wide. This space saving design frees up more space in the mechanical room. And our optional Multi-Stack™ frame lets you put two units in the footprint of just one.



Multi-Stack rear view



Our Multi-Stack Frame gives you more floor space.

Meets The Toughest Air Quality Standards

Because of our unique fan-assisted combustion process, the Copper-Fin II exceeds today's toughest NO_x emissions requirements. An independent certification laboratory test gave us a rating of less than 30 ppm — corrected to 3% O₂. And less NO_x means a cleaner environment.

Making Installation Easier...For Less

High-efficiency, fan-assisted combustion means you can use a smaller diameter vent stack — up to 8" smaller than typically required. This makes installation less expensive and less time-consuming.

Venting Options

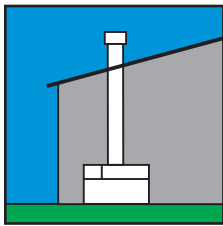

Conventional
Vents into conventional flue or vent breaching using Type B double wall vent.

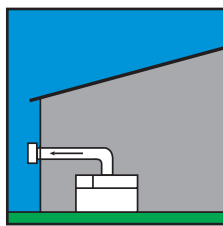

Sidewall (CF 401-751)
Draws fresh air from inside the room. Vents up to 50 equivalent feet directly through the outside wall without the need for a powered sidewall cap.

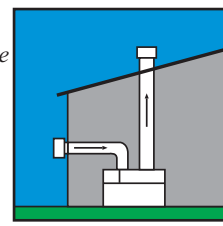

DirectAire Vertical with Sidewall Inlet
Draws fresh air from outside and vents through conventional vertical flue.

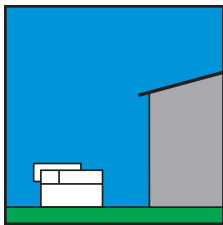

Outdoor
Requires optional outdoor vent cap. Use when indoor space is a problem or if outdoor location gives better access.

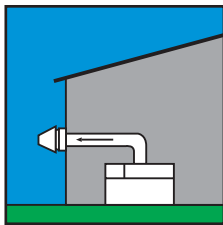

Powered Sidewall
Vents directly through the outside wall using an optional powered sidewall cap. Ideal when a vent stack is not practical.

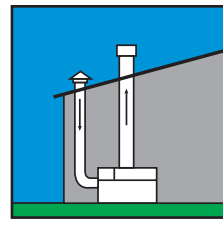

DirectAire Vertical
Draws fresh air from outside and vents through conventional vertical flue.

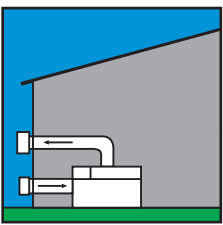

Aire-Lock Direct Vent
Utilizes sealed Aire-Lock combustion system to draw fresh air 50 equivalent feet from a sidewall. Vents horizontally up to 50 equivalent feet through the sidewall using Category IV approved vent material.

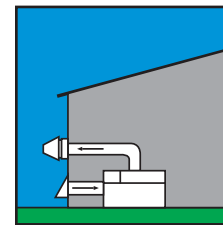

Power DirectAire Horizontal
Draws fresh air from outside and vents through sidewall using optional powered vent cap.

Vent Cost Savings

Btu/hr INPUT	CONVENTIONAL VENT SIZE	COPPER-FIN II VENT SIZE	\$ SAVINGS*
400,000	10"	6"	\$ 657.00
500,000	10"	6"	\$ 657.00
650,000	12"	8"	\$ 731.00
750,000	14"	8"	\$ 1,450.00
990,000	16"	10"	\$ 1,790.00
1,260,000	16"	12"	\$ 1,463.00
1,440,000	18"	12"	\$ 2,432.00
1,800,000	20"	14"	\$ 3,526.00
2,070,000	22"	14"	\$ 3,738.00

*Comparison based on 25' vent system using Type "B" double wall vent material, storm collar and vent cap.

Copper-Fin II® Package Systems

Our uniform fabricated package systems let you create storage and recovery solutions that perfectly match each application. Teamed with our Lock-Temp® tanks, Copper-Fin II® provides the constant water temperature needed to meet load requirements. Our package systems are pre-engineered, factory assembled on an I-beam frame and come fully assembled with all piping needed for specific applications.



Copper-Fin II® package system CFN0651PM and a 318-gallon storage tank in a PU configuration.

Our Enhanced Models Raise The Bar...Again

Our enhanced Copper-Fin II models offer the same reliable, efficient operation and feature a more service friendly design. The gas inlet and optional shutoff cocks, electrical and BMS connections have been repositioned toward the front of the unit for easier service access and simpler installation. And the new referenced gas valve design improves operational performance by monitoring the pressure in the sealed combustion chamber to maintain the optimum air/fuel mixture.

All models feature alternate air inlet connections for greater installation flexibility. This field convertible option provides the ability to connect the air inlet on either the right side or the rear of the unit. And the built-in air inlet filter reduces maintenance and improves performance by trapping dust and airborne particulates that can foul the burners and blowers.

You'll also save installation time and expense with Lochinvar's direct vent option, featuring our innovative Aire-Lock™ combustion system. The direct vent option allows the installer to vent the by-products of combustion directly through a side wall without the use of an auxiliary draft inducer. By using approved vent material and an air intake pipe, this option effectively "detaches" the unit from the mechanical room by pulling all combustion air from outside the building and venting all combustion by-products outside through a side wall. A feature that can really simplify an installation while reducing overall installed costs.

Control at your fingertips

The enhanced operator interface panel provides fingertip control of the built-in multi-stage digital temperature controller. Its refined user friendly design simplifies service while providing additional diagnostic information with fewer mechanical parts.

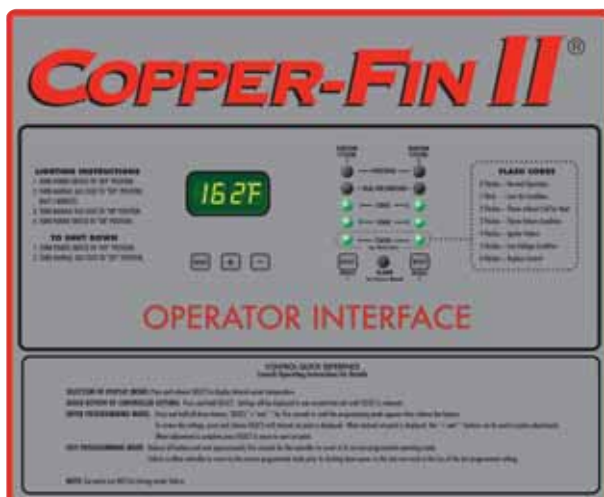

All BMS connections are on the front portion of the unit and have been designed for easier access and connection.



Referenced gas valves are in the upper deck for easier access. And our Lochinvar exclusive "Aire-Lock" transition ducts provide a positive path for the sealed combustion system that does not require the upper chamber panel to be installed allowing for accurate adjustment during operation.



For easier and more flexible installation the air inlet box is field convertible mounting on either the rear or side of the unit. With this feature the unit can be direct vented with up to 50 equivalent feet of air inlet and 50 equivalent feet of outlet vent and does not require the same pressure zone for inlet and outlet locations.

Copper-Fin II® Package Systems

Note: Additional package systems are available. Consult factory for dimensions and specifications.

PS Configuration CF 401-2071PM with a 119 to 504 gallon capacity jacketed and insulated Lock-Temp Vertical Storage Tank.

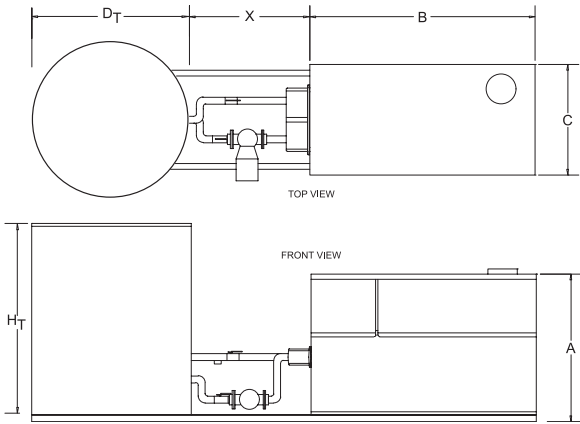

PT Configuration CF 401-2071PM with a 300 to 2500 gallon capacity jacketed and insulated Lock-Temp Horizontal Storage Tank.

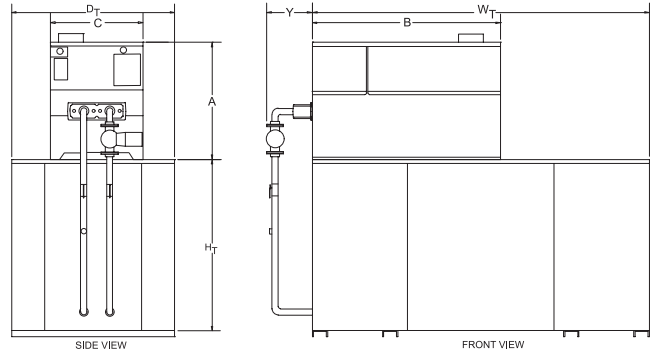

PU Configuration CF 401-2071PM with a 119 to 504 gallon capacity jacketed and insulated Lock-Temp Vertical Storage Tank.

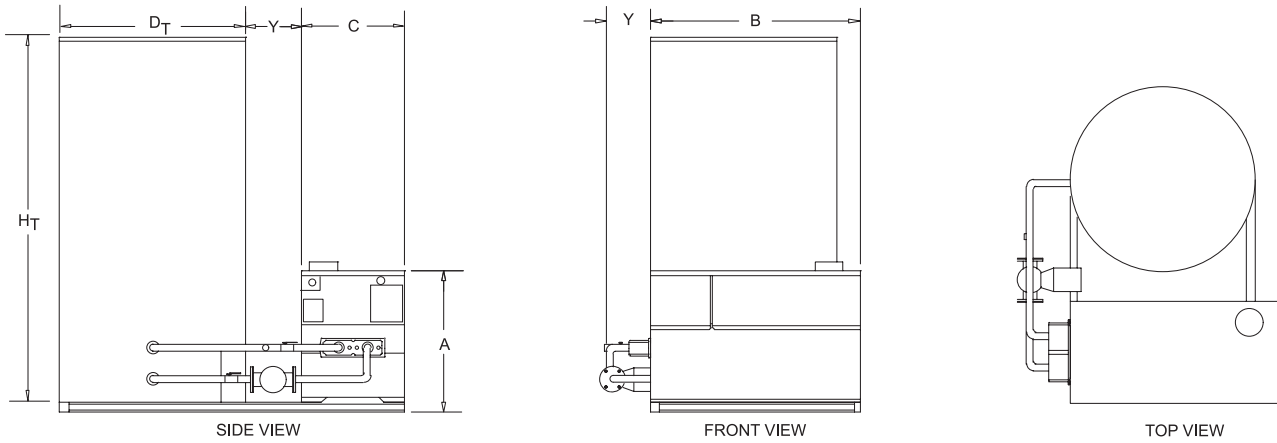

PW Configuration CF 401-2071PM with a 300 to 2500 gallon capacity jacketed and insulated Lock-Temp Horizontal Tank.

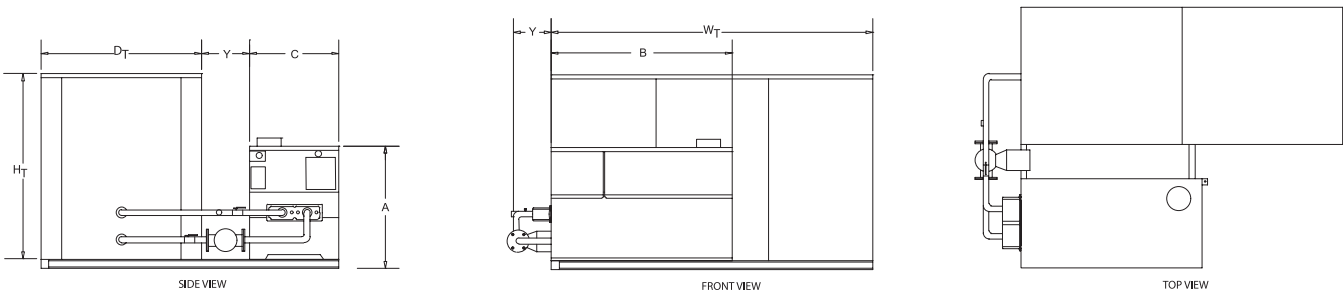

VERTICAL ROUND JACKETED TANK DIMENSIONS			
Gallon	H _t	D _t	Weight
119	62-1/2"	28"	345
200	77-1/4"	32"	600
257	91"	34"	1108
318	80"	40"	1290
432	80"	46"	1,512
504	92"	46"	1,623

PIPING DIMENSIONS	
X	Y
42"	12"

Note: For Heater Dimensions "A", "B", "C" Consult Dimensions and Specifications Table on Back Page.

HORIZONTAL TANK DIMENSIONS				
Gallons	H _t	W _t	D _t	Weight
300	50-1/2"	78-1/4"	42-1/4"	1,700
400	50-1/2"	102-1/4"	42-1/4"	2,250
500	56-1/2"	90-3/4"	48-1/4"	2,450
600	56-1/2"	114-1/4"	48-1/4"	3,350
700	56-1/2"	130-1/4"	48-1/4"	4,000
800	62-1/2"	124-1/4"	54-1/4"	4,800
1,000	62-1/2"	138-1/4"	54-1/4"	5,100
1,250	68-1/2"	130-1/4"	60-1/4"	5,900
1,500	77-1/2"	126-1/4"	66-1/4"	6,500
2,000	80-1/2"	138-1/4"	72-1/4"	9,000
2,500	86-1/2"	144-1/4"	78-1/4"	10,000

NOTE: If overall dimensions are critical consult factory.

All package systems are skid mounted.

*Add 3" to tank H_t for I-Beam skid.

Copper-Fin II® Water Heater Dimensions & Specifications

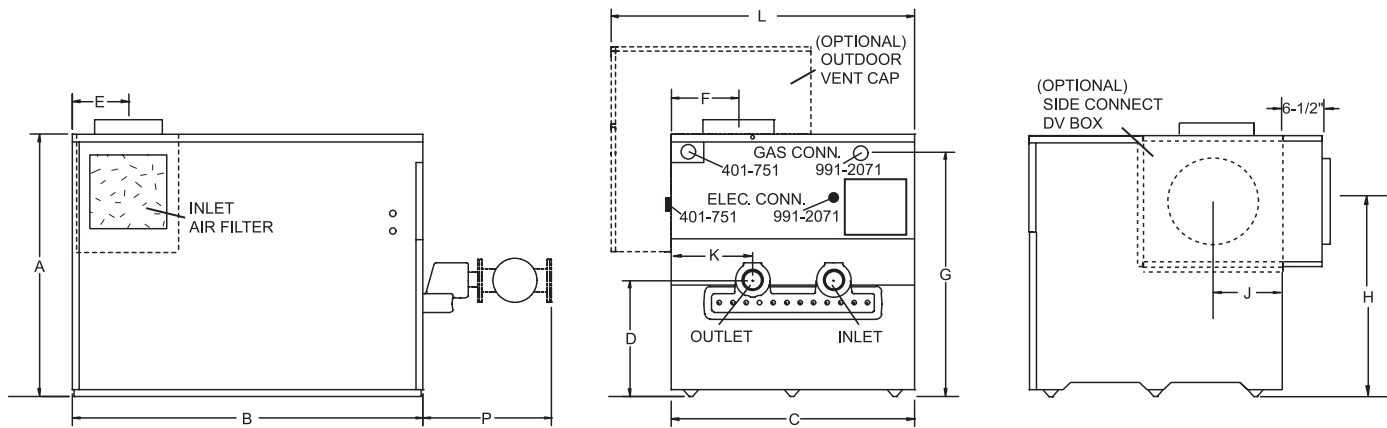

Model Number	Btu/hr Input	GPH @ 100°F Rise	A	B	C	D	E	F	G	H	J	K	L	P	Vent Size	Air Inlet	Gas Conn	Shipping Weight
CFN401PM	399,999	412	31-1/2"	37-3/4"	22-1/4"	12-1/2"	7"	7"	29"	23-1/2"	8"	6-1/2"	30-3/4"	18-1/2"	6"	6"	1-1/4"	430
CFN501PM	500,000	515	31-1/2"	45-1/2"	22-1/4"	12-1/2"	7"	7"	29"	23-1/2"	8"	6-1/2"	30-3/4"	18-1/2"	6"	6"	1-1/4"	480
CFN651PM	650,000	670	31-1/2"	56-3/4"	22-1/4"	12-1/2"	8-1/2"	8-1/4"	29"	23-1/2"	8"	6-1/2"	30-3/4"	18-1/2"	8"	8"	1-1/4"	550
CFN751PM	750,000	773	31-1/2"	64"	22-1/4"	12-1/2"	8-1/2"	8-1/4"	29"	23-1/2"	8"	6-1/2"	30-3/4"	18-1/2"	8"	8"	1-1/4"	605
CFN0991PM	990,000	1,020	36"	48-1/4"	33-1/2"	15-3/4"	8"	9-1/4"	33-3/4"	27"	9-1/4"	9"	41-3/4"	20-1/2"	10"	10"	2"	930
CFN1261PM	1,260,000	1,298	36"	58-1/2"	33-1/2"	15-3/4"	9"	10-1/4"	33-3/4"	27"	9-1/4"	9"	41-3/4"	20-1/2"	12"	12"	2"	995
CFN1441PM	1,440,000	1,484	36"	68-3/4"	33-1/2"	15-3/4"	9"	10-1/4"	33-3/4"	27"	9-1/4"	9"	41-3/4"	20-1/2"	12"	12"	2"	1,130
CFN1801PM	1,800,000	1,855	36"	82-1/4"	33-1/2"	15-3/4"	10"	11-1/2"	33-3/4"	27"	9-1/4"	9"	41-3/4"	20-1/2"	14"	12"	2"	1,285
CFN2071PM	2,070,000	2,133	36"	92-1/2"	33-1/2"	15-3/4"	10"	11-1/2"	33-3/4"	27"	9-1/4"	9"	41-3/4"	20-1/2"	14"	12"	2"	1,400

Notes: Change 'N' to 'L' for LP gas models.

Water connections for models (CF 401-751) are 2" NPT on 6-1/2" centers.

Performance data is based on manufacturer test results.

No deration on LP models.

Water connections for models (CF 0991-2071) are 2-1/2" NPT on 11-1/4" centers.

Standard Features

- 85% Thermal Efficiency
- ASME Copper Finned Tube Heat Exchanger
- Gasketless Heat Exchanger Design
- Proportional Firing
- Built-In Sequencer with up to 4 Stages of Operation
- Digital Operator Interface Panel
- Sealed Combustion Chamber
- Stainless Steel Burners
- Low NOx Operation Exceeds the most Stringent Air Quality Requirements
- 160 PSI Working Pressure
- All Bronze Circulating Pump
- Pump Delay
- Glass-Lined Water Surfaces
- Loch-Heat Ceramic Tile Combustion Chamber
- Hot Surface Ignition
- ASME Temperature & Pressure Relief Valve
- Inlet & Outlet Temperature Gauges
- Referenced Gas Valves
- Field Convertible Air Inlet Connection
- Adjustable High Limit w/ Manual Reset

- Combustion Air Filter
- Freeze Protection
- Complete System Redundancy
- Flow Switch
- 24 Volt Control System
- BMS Terminal Strip
- 5 Year Limited Warranty on Heat Exchanger (See warranty for details)

Optional Equipment

- Alarm Bell
- Contacts for Air Louvers
- Contacts on any Failure
- Cupro-Nickel Heat Exchanger
- Down Stream Test Valves
- High Gas Pressure Switch w/ Manual Reset
- Low Gas Pressure Switch w/ Manual Reset
- Low Water Cut-Off w/ Manual Reset & Test
- Run Time Contacts
- Multi-Stack Frame
- Combustible Floor Shield (CF 401-751)
- MP² Sequencer

Venting Options

- Aire-Lock™ Direct Vent Sealed Combustion
- DirectAire® Vertical
- DirectAire® Vertical w/ Sidewall Inlet
- Outdoor Installation
- Power DirectAire® Horizontal
- Powered Side Wall
- Sidewall (CF 401-751)
- Intelligent Venting Solutions

Firing Controls

- M9 Hot Surface Ignition with Electronic Supervision (Standard)
- M13 GE GAP/FM/IRI
- M7 California Code

For Ease In Ordering By Model Number



This heater is 500,000 Btu/hr natural gas Copper-Fin II water heater. It has M9 firing controls.



Lochinvar
High Efficiency Water Heaters, Boilers and Pool Heaters



Lochinvar Corporation • 300 Maddox Simpson Pkwy • Lebanon, TN 37090 • 615-889-8900 / Fax: 615-547-1000

www.Lochinvar.com