



INSTALLATION, OPERATING AND SERVICE MANUAL

DIAMOND LINE LX ELECTRONIC WATER SOFTENER WITH THE X-FACTOR CONTROL VALVE PROGRAMMED FOR PRE-FILL BRINING OPTION

- 7-LXC-50B
- 7-LXC-75B
- 7-LXC-100B
- 7-LX-75B
- 7-LX-100B
- 7-LX-150B
- 7-LX-200B
- 7-LX-300B



Congratulations on purchasing your new **Lancaster Water Softener**. This unit is designed to give you many years of trouble free service. When installed in accordance with the following instructions and if given reasonable care, clear-soft water will be the result. For servicing and future inspection purposes, please file this booklet with your important documents.

In the event that you need assistance for servicing your water softener, please first contact the professional contractor who installed the system.

TABLE OF CONTENTS

Job Specifications	2
General Installation and Service Warnings	3
Pre-Installation Review	4
Bypass Valve Operation	5
Installation Instructions, Diagrams	6-8
Placing Softener into Service	9
General Operation	9
Set Time of Day	10
Adjust Hardness, Days Between Regenerations or Time of Regeneration	10-11
Low Battery.....	11
Contact Screen Programming	11
Specifications	12-15
Parts Diagrams	16-23
Service Instructions	24-26
Troubleshooting	27-30

JOB SPECIFICATIONS

MODEL NO. _____
INSTALLATION DATE _____
SERIAL NUMBER _____
INSTALLER NAME _____ PHONE _____
ADDRESS _____

WATER TEST AT TIME OF INSTALLATION

_____ Hardness CaCo₃ (gpg) Other: _____
_____ Iron (ppm) _____
_____ pH _____

SIZING INFORMATION

All Water is Softened Except:

_____ Rear Hose Bib _____ Front Hose Bib _____ Kitchen Cold _____ Toilets _____ All Cold
_____ Other _____

The average family uses 50 gallons per person daily for all water uses in the home.

_____ Daily Water Usage (Gallons/Person)

x _____ Family Size (Number of people in family)

= _____ Total Gallons Per Day

x _____ Grains Per Gallon of hardness

(Note: Add 4 grains per gallon of hardness for each ppm iron for total compensated hardness)

= _____ Total Grains per Day

GENERAL INSTALLATION AND SERVICE WARNINGS

The control valve, fittings and/or bypass are designed to accommodate minor plumbing misalignments but are not designed to support the weight of a system or the plumbing.

HYDROCARBONS SUCH AS KEROSENE, BENZENE, GASOLINE, ETC., MAY DAMAGE PRODUCTS THAT CONTAIN O-RINGS OR PLASTIC COMPONENTS. EXPOSURE TO SUCH HYDROCARBONS MAY CAUSE THE PRODUCTS TO LEAK. DO NOT USE THE PRODUCT(S) CONTAINED IN THIS DOCUMENT ON WATER SUPPLIES THAT CONTAIN HYDROCARBONS SUCH AS KEROSENE, BENZENE, GASOLINE, ETC.

THIS WATER METER SHOULD NOT BE USED AS THE PRIMARY MONITORING DEVICE FOR CRITICAL OR HEALTH EFFECT APPLICATIONS

Do not use Vaseline, oils, other hydrocarbon lubricants or spray silicone anywhere. A silicone lubricant may be used on black o-rings but is not necessary.

The nuts and caps are designed to be unscrewed or tightened by hand or with the special plastic wrench. If necessary a pliers can be used to unscrew the nut or cap. Do not use a pipe wrench to tighten or loosen nuts or caps. Do not place a screwdriver in the slots on caps and/or tap with a hammer.

Do not use pipe dope or other sealants on threads. Use Teflon tape on the threaded inlet, outlet and drain fittings. Teflon tape is not necessary on the nut connection or caps because of o-ring seals.

After completing any valve maintenance involving the drive assembly or the drive cap assembly and pistons unplug power source jack from the printed circuit board (black wire) and plug back in or press and hold NEXT and REGEN buttons for 3 seconds.

This resets the electronics and establishes the service piston position. The display should flash all wording, then flash the software version and then reset the valve to the service position.

All plumbing should be done in accordance with local plumbing codes. The pipe size for the drain line should be a minimum of ½". Backwash flow rates in excess of 7 gpm or length in excess of 20' require ¾" drain line.

Solder joints near the drain must be done prior to connecting the drain line flow control fitting. Leave at least 6" between the drain line control fitting and solder joints when soldering pipes that are connected on the drain line control fitting. Failure to do this could cause interior damage to the drain line flow control fitting.

When assembling the installation fitting package (inlet and outlet), connect the fitting to the plumbing system first and then attach the nut, split ring and o-ring. Heat from soldering or solvent cements may damage the nut, split ring or o-ring. Solder joints should be cool and solvent cements should be set before installing the nut, split ring and o-ring. Avoid getting primer and solvent cement on any part of the o-rings, split rings, bypass valve or control valve.

Plug into an electrical outlet. Note: All electrical connections must be connected according to local codes. (Be certain the outlet is uninterrupted.)

Install grounding strap on metal pipes.

This glass filled Noryl (or equivalent) fully automatic control valve is designed as the primary control center to direct and regulate all cycles of a water softener or filter. The control valve can be set to regenerate on demand (consumption of a predetermined amount of water) and/or as a time clock (passage of a particular number of days). The control valve can be set so that a softener can meet the Water Quality Association (WQA) Standard S100 or NSF/ANSI Standard 44 efficiency rating.

It is not recommended to change control valves from downflow to upflow brining or vice versa in the field. The valve bodies for downflow and upflow are unique to the regeneration type and should not be interchanged. A mismatch of valve body and regeneration piston will result in hard water bypass during service.

The control valve is compatible with a variety of regenerants and resin cleaners. The control valve is capable of routing the flow of water in the necessary paths to regenerate or backwash water treatment systems. The injector regulates the flow of brine or other regenerants. The control valve regulates the flow rates for backwashing, rinsing, and the replenishing of treated water into a regenerant tank, when applicable. The control valve uses no traditional fasteners (e.g. screws); instead clips, threaded caps and nuts and snap type latches are used. Caps and nuts only need to be firmly hand tightened because radial seals are used. Tools required to service the valve include one small blade screw driver, one large blade screw driver, pliers and a pair of hands. A plastic wrench is available which eliminates the need for screwdrivers and pliers. Disassembly for servicing takes much less time than comparable products currently on the market. Control valve installation is made easy because the distributor tube can be cut ½" above to ½" below the top of tank thread. The distributor tube is held in place by an o-ring seal and the control valve also has a bayonet lock feature for upper distributor baskets.

The AC adapter comes with a 15 foot power cord and is designed for use with the control valve. The AC adapter is for dry location use only. The control valve remembers all settings until the battery power is depleted if the power goes out. After the battery power is depleted, the only item that needs to be reset is the time of day; other values are permanently stored in the nonvolatile memory. The control valve battery is not rechargeable but is replaceable.

Allow one foot of clearance to service the valve.

PRE-INSTALLATION REVIEW

WATER QUALITY: If sand or sediment is present in the water supply, a sediment filter should be installed ahead of the water softener. Your water softener has been designed to adequately reduce hardness from levels up to 100 grains per gallon. Ferrous bicarbonate iron levels up to 0.5 ppm can also be reduced. This is iron that is dissolved in water and not visible to the eye in a freshly drawn sample. After standing in contact with air, the ferrous iron will become oxidized to the ferric state and start to precipitate as a reddish brown floc. It can be seen and may cause discolored water. Air must not come in contact with water until after it has passed through the water softener. In some cases, additional treatment equipment may be needed to treat water having special characteristics, such as: ferric hydroxide iron, iron bacteria, low pH, tastes and odors, etc. Consult your dealer if you have any questions. **This water softener is not to be used for treating water that is microbiologically unsafe or of unknown quality without adequate disinfection before or after treatment.**

WATER PRESSURE: A minimum of 20 pounds of water pressure (psi) is required for regeneration. Maximum 100 psi. CAUTION: the softener cannot be subject to a vacuum due to loss of pressure (such as a water main break or submersible well pump check valve failure).

WATER TEMPERATURE: The range of water temperature is 40°F to 100°F. DO NOT install any water softener with less than 10 feet of piping between its outlet and the inlet of a water heater.

AMBIENT TEMPERATURE: DO NOT locate softener where it or its connections (including the drain and overflow lines) will ever be subject to room temperatures under 33°F.

ELECTRICITY: An uninterrupted 120 volt 60Hz source is required. *Make sure electrical source is not on a timer or switch.* All electrical connections must be connected according to local codes. The plug-in transformer is for dry locations only. Surge protection is recommended with all electrical connections.

DRAIN: All plumbing should be done in accordance with local plumbing codes. The distance between the drain and the water softener should be as short as possible. The pipe size for the drain line should be a minimum of 1/2" (inside diameter of pipe).

SOFTENING: It is recommended that the softener be installed to soften both the hot and cold water supply. A separate hard water faucet may be plumbed for drinking purposes if desired. Outside faucets should be left on hard water.

BYPASS: A bypass valve should be installed so that water will be available if it should be necessary to shut off the pressure in order to service the softener.

BYPASS VALVE

The bypass valve is typically used to isolate the control valve from the plumbing system's water pressure in order to perform control valve repairs or maintenance. The X-Factor bypass valve is particularly unique in the water treatment industry due to its versatility and state of the art design features. The 1" full flow bypass valve incorporates four positions, including a diagnostic position that allows service personal to work on a pressurized system while still providing untreated bypassed water to the facility or residence. Its completely non-metallic, all-plastic design allows for easy access and serviceability without the need for tools.

The bypass body and rotors are glass filled Noryl® (or equivalent) and the nuts and caps are glass filled polypropylene. All seals are self-lubricating EPDM to help prevent valve seizing after long periods of non-use. Internal o-rings can easily be replaced if service is required.

The bypass consists of two interchangeable plug valves that are operated independently by red arrow-shaped handles. The handles identify the flow direction of the water. The plug valves enable the bypass valve to operate in four positions.

OPERATION:

1. Normal Operation Position: The inlet and outlet handles point in the direction of flow indicated by the engraved arrows on the control valve. Water flows through the control valve during normal operation and this position also allows the control valve to isolate the media bed during the regeneration cycle. (see figure 1)

2. Bypass Position: The inlet and outlet handles point to the center of the bypass, the control valve is isolated from the water pressure contained in the plumbing system. Untreated water is supplied to the plumbing system. (see figure 2)

3. Diagnostic Position: The inlet handle points in the direction of flow and the outlet handle points to the center of bypass valve, system water pressure is allowed to the control valve and the plumbing system while not allowing water to exit from the control valve to the plumbing. (see figure 3)

4. Shut Off Position: The inlet handle points to the center of the bypass valve and the outlet handle points in the direction of flow, the water is shut off to the plumbing system. If water is available on the outlet side of the softener it is an indication of water bypass around the system (i.e. a plumbing connection somewhere in the building bypasses the system). (see figure 4)

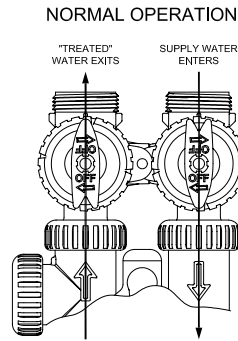

figure 1

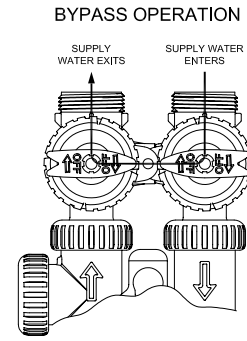

figure 2

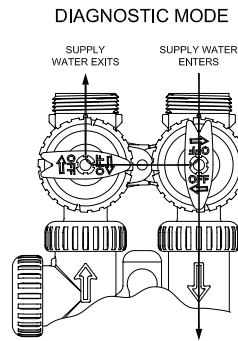

figure 3

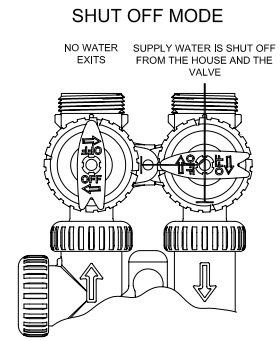

figure 4

The working parts of the bypass valve are the rotor assemblies that are contained under the bypass valve caps. Before working on the rotors, make sure the system is depressurized. Turn the red arrow shaped handles towards the center of the bypass valve and back several times to ensure rotor is turning freely.

The nuts and caps are designed to be unscrewed or tightened by hand. If necessary a pliers can be used to unscrew the nut or cap. Do not use a pipe wrench to tighten or loosen nuts or caps. Do not place screwdriver in slots on caps and/or tap with a hammer. To access the rotor, unscrew the cap and lift the cap, rotor and handle out as one unit. Twisting the unit as you pull it out will help to remove it more easily. There are three o-rings: one under the rotor cap, one on the rotor stem and the rotor seal. Replace worn o-rings. Clean rotor. Reinstall rotor.

When reinstalling the red arrow handles be sure that:

1. The handle pointers are lined up with the control valve body arrows, and the rotor seal o-ring and retainer on both rotors face to the right when being viewed from the front of the control valve; or
2. Arrows point toward each other in the bypass position.

Since the handles can be pulled off, they could be accidentally reinstalled 180° from their correct orientation. To install the red arrow handles correctly, keep the handles pointed in the same direction as the arrows engraved on the control valve body while tightening the bypass valve caps.

INSTALLATION INSTRUCTIONS

(All electrical & plumbing should be done in accordance to all local codes)

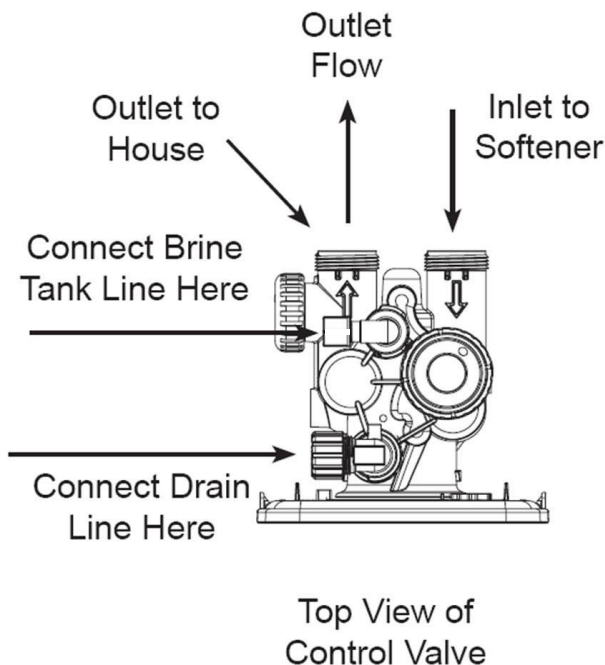

1. Place the softener where you want to install it, making sure it is on a clean, level and firm base.

2. Do all necessary plumbing (inlet to inlet, outlet to outlet, and drain line to drain). The control valve, fittings and/or bypass are designed to accommodate minor plumbing misalignments but are not designed to support the weight of a system or the plumbing.

3. When assembling the installation fitting package (inlet and outlet), connect the fitting to the plumbing system first and then attach the nut, split ring and o-ring. Heat from soldering or solvent cements may damage the nut, split ring or o-ring. Solder joint should be cool and solvent cements should be set before installing the nut, split ring and o-ring. Avoid getting primer and solvent cement on any part of the o-rings, split rings, bypass valve or control valve.

4. A jumper ground wire should be installed between the inlet and outlet pipe whenever the metallic continuity of a water distribution piping system is interrupted. Install grounding strap on metal pipes.

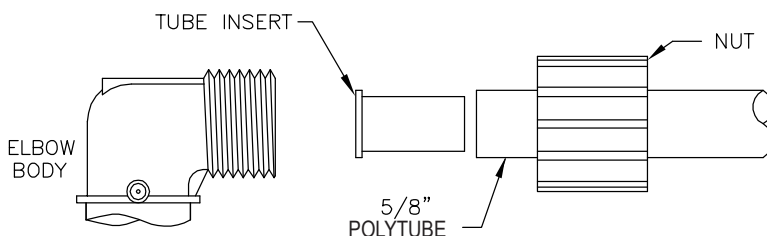

DRAIN LINE FITTING CONNECTION USING 5/8" POLYTUBE

5. The drain connection may be made using either 5/8" polytube (see below) or a 3/4" female adapter. The polytube insert is shipped attached to the drain line elbow's locking clip. Press the insert into the drain line tubing (tubing not provided). Loosen the nut of the drain line elbow. Press the 5/8" polytube with insert into the drain line elbow until it seats on the back of the fitting. Tighten the nut. If soldering, joints near the drain must be done prior to connecting the drain line flow control fitting. Leave at least 6" between the drain line control fitting and solder joints when soldering pipes that are connected on the drain line control fitting. Failure to do this could cause interior damage to the drain line flow control fitting. Never insert a drain line into a drain, sewer line, or trap. Always allow an air gap between the drain line and the wastewater to prevent the possibility of sewage being back-siphoned into the softener.

INSTALLATION INSTRUCTIONS CONT'D

(All electrical & plumbing should be done in accordance to all local codes)

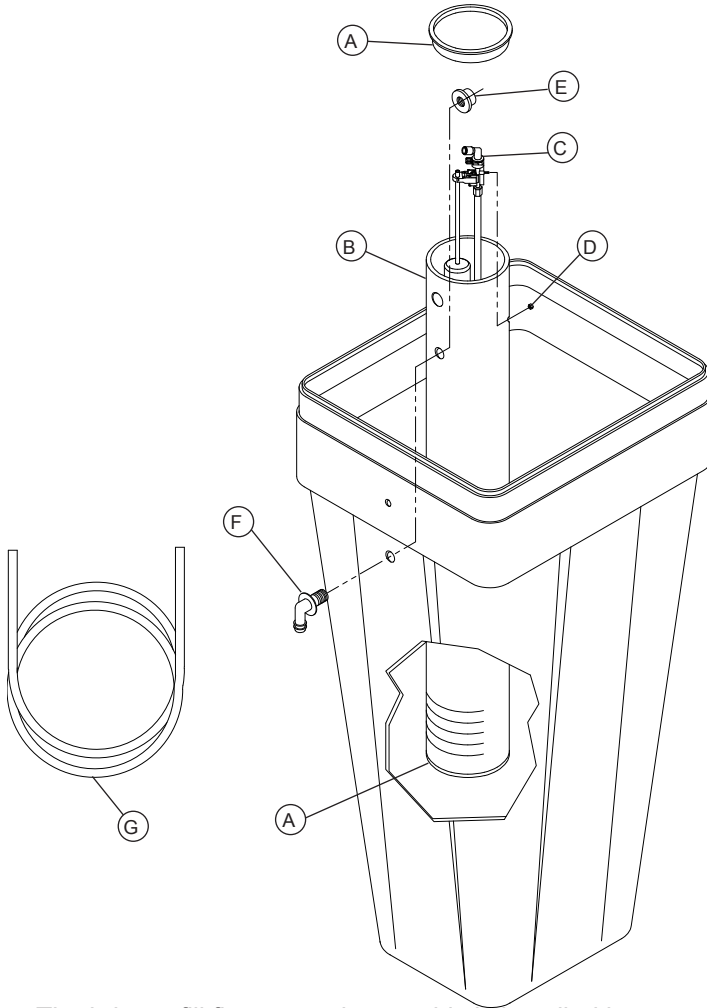

6. Assemble the brine tank. Install a brine well cap (Item A) on the bottom of the brine well (Item B). Remove the brine valve assembly (Item C) from the brine well by removing the nut (Item D). Attach the brine well to the brine tank with the two-piece overflow (Items E & F) using the lower holes in both pieces, as shown. Reinstall the brine valve assembly. Push brine line polytube (Item G) through the upper holes in the brine tank and brine well and press the polytube into the elbow fitting.

7. The brine refill flow control assembly is installed in an easy to access refill elbow located on top of the control valve. The refill flow control assembly is attached to the control valve with a locking clip. The locking clip allows the elbow to rotate 270 degrees so the outlet can be oriented towards the brine tank.

8. Connect the brine line polytubing found with the brine tank to the brine connection on the control valve. The control valve has a standard refill elbow to which a 3/8" flexible tube can be connected, see below. Press the polytube into the brine elbow fitting. Make sure the floor is clean beneath the brine tank and that it is level and smooth.

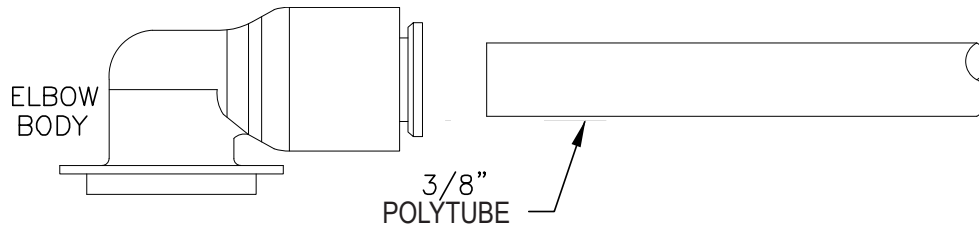

BRINE LINE FITTING CONNECTIONS

9. A 1/2" (inside diameter, not provided) gravity drain line should be connected to the overflow fitting on the side of the brine tank. This overflow is in case of a malfunction in the brine shut off. If the unit is installed where water may flow in the event of an overflow and cause water damage, connect a length of flexible tubing and run to a drain below the level of the overflow. **(Do not connect the tubing to the drain line on the control valve. Do not run tubing above overflow height at any point.)**

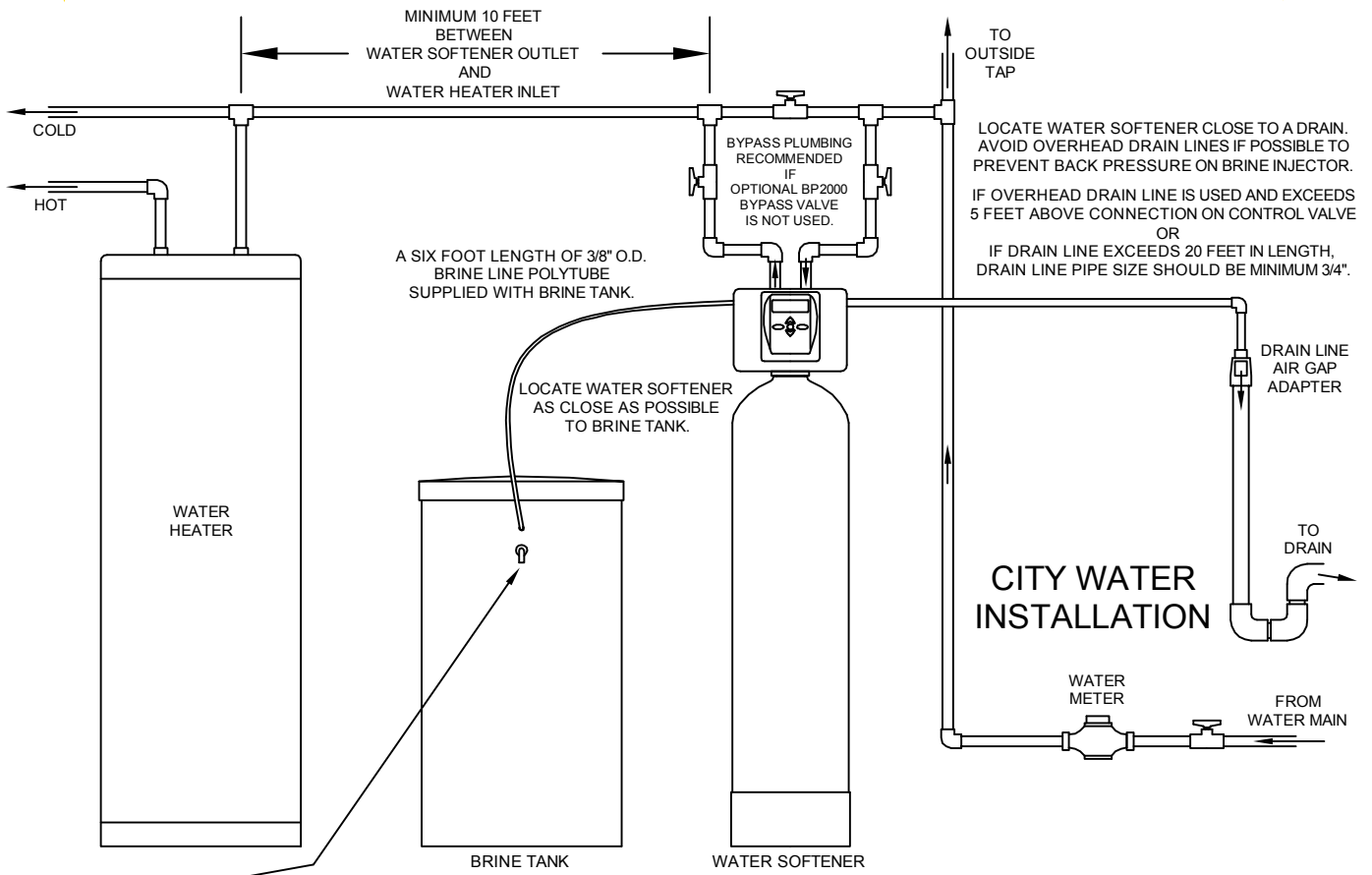

OVERFLOW GRAVITY DRAIN - ONLY USED IN CASE OF MALFUNCTION IN THE BRINE SHUTOFF. DO NOT CONNECT TO CONTROL VALVE DRAIN LINE. IF UNIT IS INSTALLED WHERE OVERFLOW COULD CAUSE WATER DAMAGE, CONNECT TUBING AND RUN TO FLOOR DRAIN. DO NOT RUN TUBING ABOVE OVERFLOW HEIGHT.

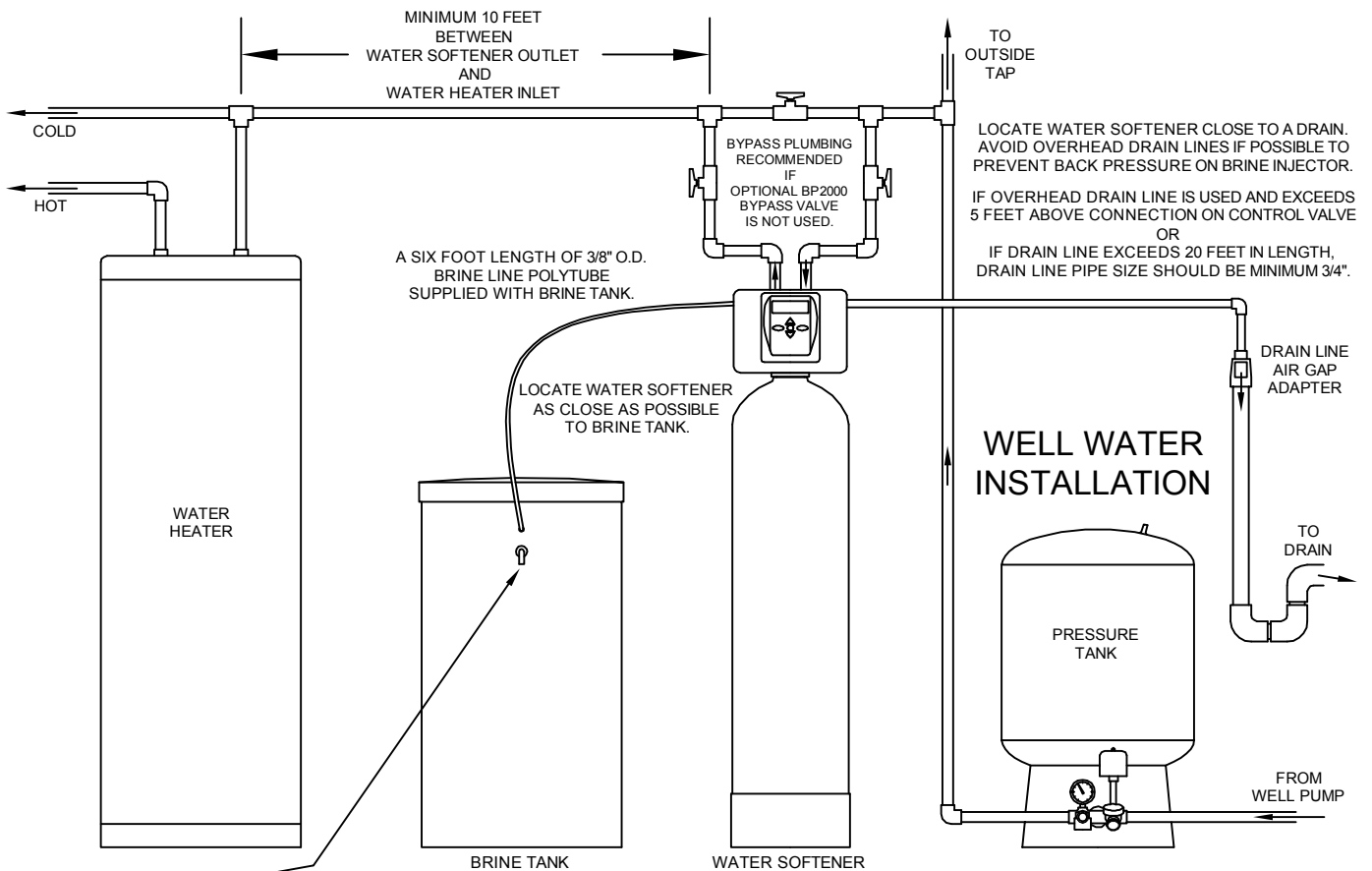

OVERFLOW GRAVITY DRAIN - ONLY USED IN CASE OF MALFUNCTION IN THE BRINE SHUTOFF. DO NOT CONNECT TO CONTROL VALVE DRAIN LINE. IF UNIT IS INSTALLED WHERE OVERFLOW COULD CAUSE WATER DAMAGE, CONNECT TUBING AND RUN TO FLOOR DRAIN. DO NOT RUN TUBING ABOVE OVERFLOW HEIGHT.

PLACING SOFTENER INTO SERVICE

Do not add salt to the brine tank yet. Do not plug the transformer into the receptacle yet. Make sure inlet and outlet valves are to their closed positions. If using optional bypass, place in bypass position. Turn on main water supply. Open a cold water faucet. This will clear the line of any debris (solder, pipe dope, etc.) that may be in the line. Let water run at faucet for a couple minutes, or until clear. Turn off faucet. Manually add 1 ½ gallons of water to the brine tank. Now plug the transformer into a 120 volt receptacle (be certain the receptacle is uninterrupted). Within 5 seconds the control display and buttons will illuminate and the time of day screen will appear.

- Press and hold the **REGEN** button for approximately 5 seconds until the motor starts.
- Wait until display reads **FILL** and numbers start counting down.
- Momentarily press **REGEN** again. Valve is now in the **SOFTENING** position.
- Momentarily press **REGEN** again. Valve is now in the **BACKWASH** position. (NA for model 7-LXC-50, -100)
- Momentarily press **REGEN** again. Valve is now in the **REGENERANT DRAW** position.
- Momentarily press **REGEN** again. Valve is now in the second **BACKWASH** position. (NA for model 7-LXC-50, -100)

If using optional bypass **SLOWLY** turn bypass valve to **DIAGNOSTIC** position (See figure 3 on page 5) or slowly open inlet valve to allow water to slowly enter Softener.

When water is flowing steadily to drain without the presence of air, momentarily press **REGEN** again. Display will read **RINSE**. Open the outlet valve of the softener, or if using optional bypass place to **NORMAL OPERATION MODE** (see figure 1 on page 5). Allow control to finish the **RINSE** cycle. Allow the control to automatically advance to the **SOFTENING** position. Now load the brine tank with salt. Solar Salt is recommended. The brine tank salt level should be checked every couple of weeks to determine salt usage. Keeping the brine tank salt level at least 1/2 full is recommended.

SANITIZING: Use 2 oz. of 5 ¼% unscented household chlorine bleach for each cubic foot of resin. Pour bleach directly into the 4" diameter white brine well located inside the brine tank. Press and hold the **REGEN** for 5 - 6 seconds until the motor starts running. Allow system to complete the regeneration automatically. Check for other local and state codes which may also specify sanitation methods.

Note: The first step of the regeneration process is to fill the brine tank with the proper amount of water. The brine tank will only have a very slight amount of water in it after the regeneration cycles are completed.

GENERAL OPERATION

Note: As an energy saving feature, the control will automatically turn off all **SOLID BLUE** or **SOLID GREEN** display illumination and keypad illumination after about 5 minutes of the last keypad button push. Any further keypad touch will cause the re-illumination of the display and keypad, and re-activate keypad control.

User Displays

When the system is in normal service mode, one of up to five available User Displays will be shown. Pressing **NEXT** will alternate between the following displays:

- Current time of day
- Treated water flow rate
- Service contact name and phone number (if entered)
- Remaining Capacity of treated water available
- Remaining days to regeneration (if Day Override is programmed)

Pressing the **▽** button while in the Capacity Remaining or Days Remaining displays will decrease the capacity remaining in ten gallon increments or the days remaining in one day increments.

To clear the Service Call reminder, press the **▲** and **▽** buttons simultaneously while the number and banner text screen is displayed.

If the system has called for a regeneration that will occur at the preset time of regeneration, the words **REGEN TODAY** will alternate with the header on the display.

Utilizing the control valve's built-in water meter, a water drop flashes on the display when water is being treated (i.e. water is flowing through the system).

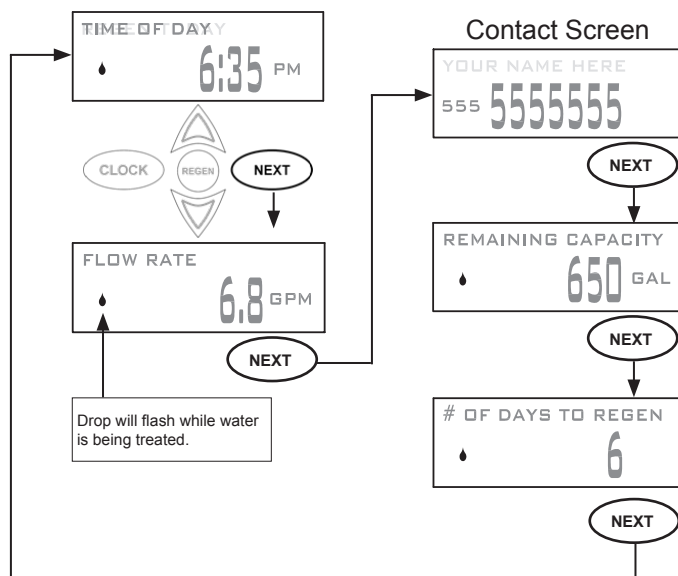

SET TIME OF DAY

Current time of day needs to be entered during initial installation, and adjusted when daylight saving time begins or ends. If an extended power outage occurs and depletes the on-board non-rechargeable coin cell battery, when power resumes the time of day should be reset and battery replaced.

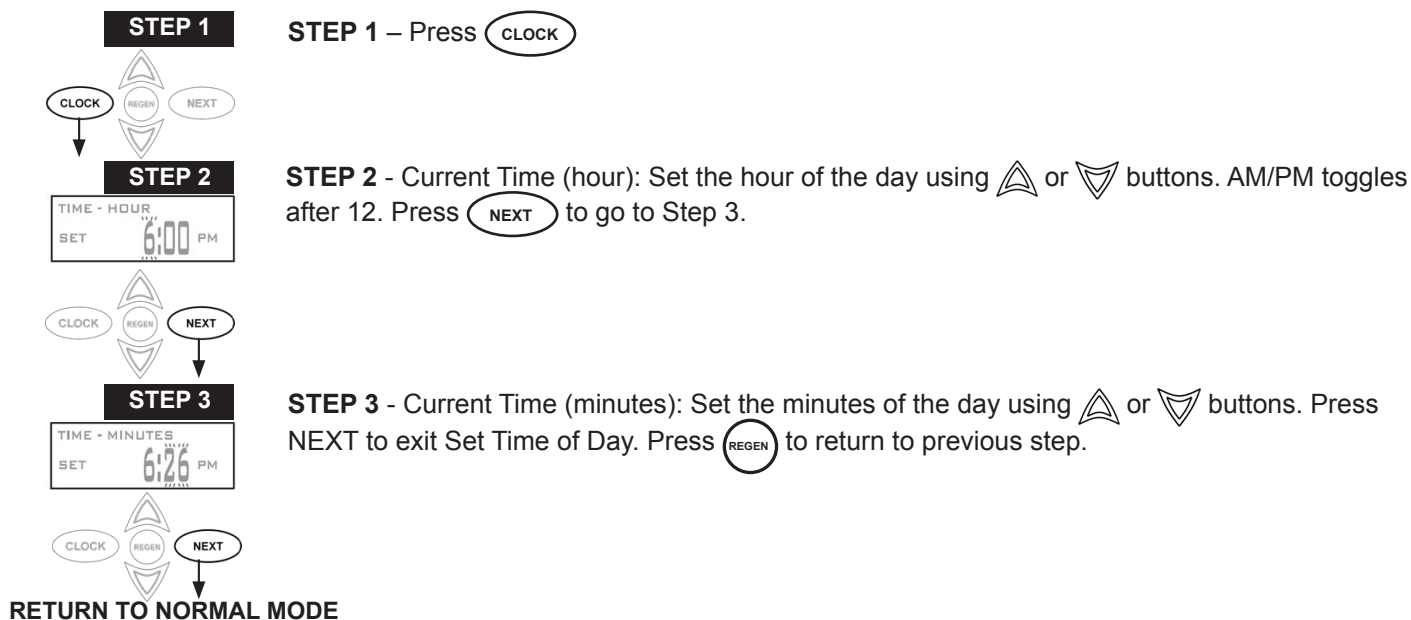

ADJUST HARDNESS, DAYS BETWEEN REGENERATIONS, OR TIME OF REGENERATION

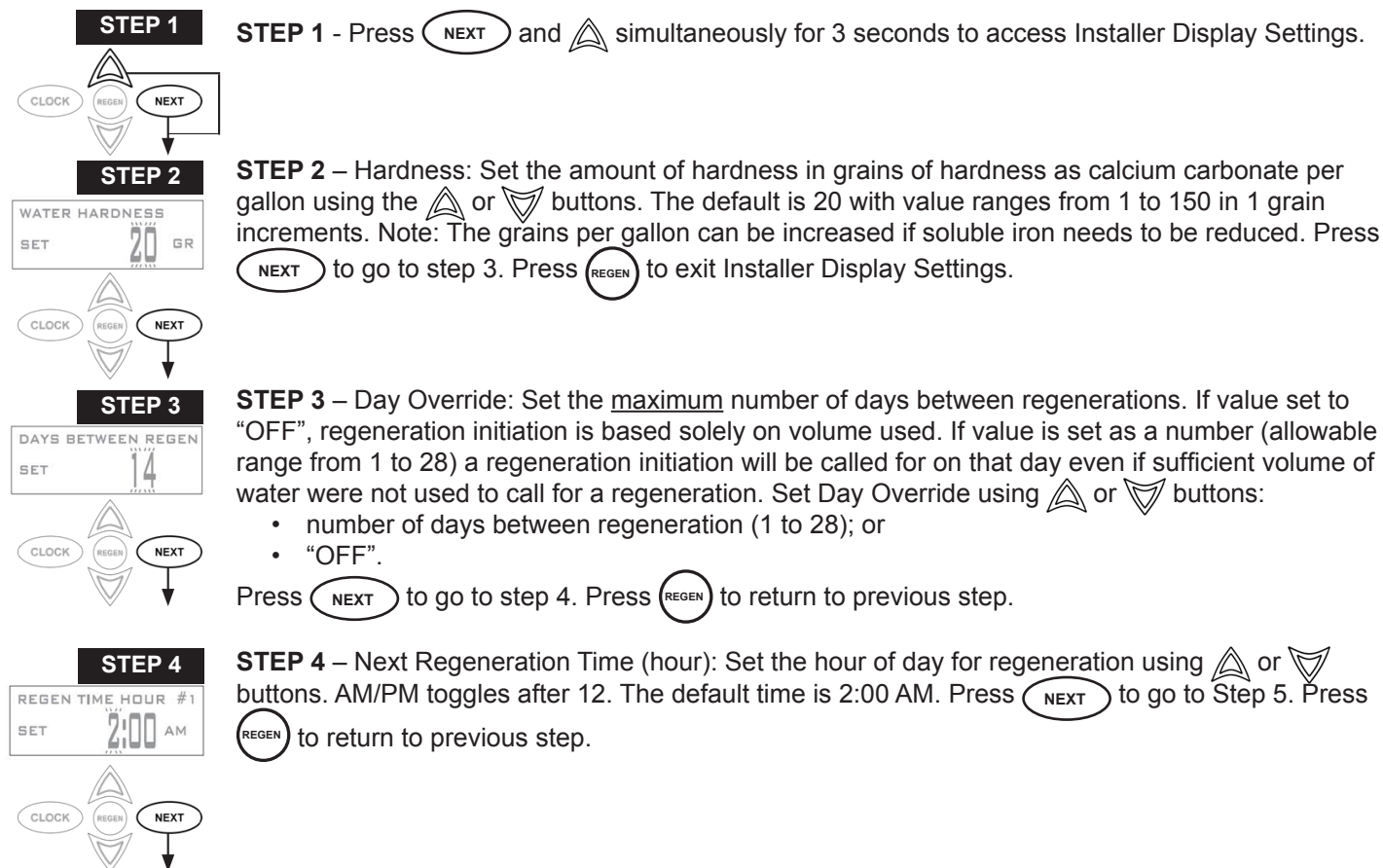



RETURN TO NORMAL MODE

STEP 5 – Next Regeneration Time (minutes): Set the minutes of day for regeneration using or buttons. Press to return to normal operation. Press to return to previous step.

LOW BATTERY

A non-rechargeable coin cell battery is located on the circuit board, used only to maintain the time of day during power outages (all other information will be stored in memory no matter how long the power outage). The screen displays LOW BATTERY when the battery needs to be replaced. The screen will remain illuminated solid blue when LOW BATTERY is displayed. Initially LOW BATTERY display will alternate with the User display, finally displaying only LOW BATTERY. User displays are still accessible by pressing .

CONTACT SCREEN PROGRAMMING

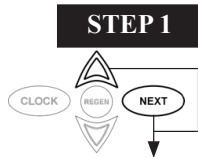

STEP 1 - Press and simultaneously for 3 seconds to access Installer Display Settings.



STEP 2 - Press to go to step 3.

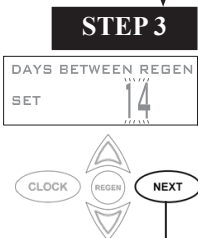

STEP 3 - Press to go to step 4.

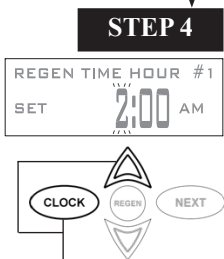

From Step 4, while hour is flashing, press and hold both the and button to change phone number and banner text.



Phone Number - Set phone number using the or arrow. Press to forward to the next digit. Press to return to previous digit.

Banner Text - Set the banner text up to a maximum of 44 characters. Use the or to select letters of the alphabet, numbers, ampersand (&), or a space in the banner text. Press to forward to the next character or to exit the Installer Display Settings.

X FACTOR SERIES GENERAL SPECIFICATIONS

1" Control Valve Size; W" x L" x H"	9.3 x 10.5 x 7.0
Inlet/Outlet Fitting Options; inches	3/4 to 1.25
Drain Pipe NPT (OD Poly Tube) Size; inches	3/4 (5/8)
Working Pressure; Min to Max (PSI)	20 to 100
Water Operating Temp; Min to Max (°F)	35 to 100
AC Adaptor Input; Voltage - Hertz	120V AC - 60 Hz
AC Adaptor Output; Voltage - Current	12V AC - 500 mA
3 Volt Lithium Coin Cell Battery; type	2032
PC Board Relay Terminal Block DC Output; Voltage	12V DC **

** Relay Specifications: 12V DC Relay with a coil resistance not less than 80 ohms. If mounting the relay under the control valve cover, check for proper mounting location dimensions on the backplate.

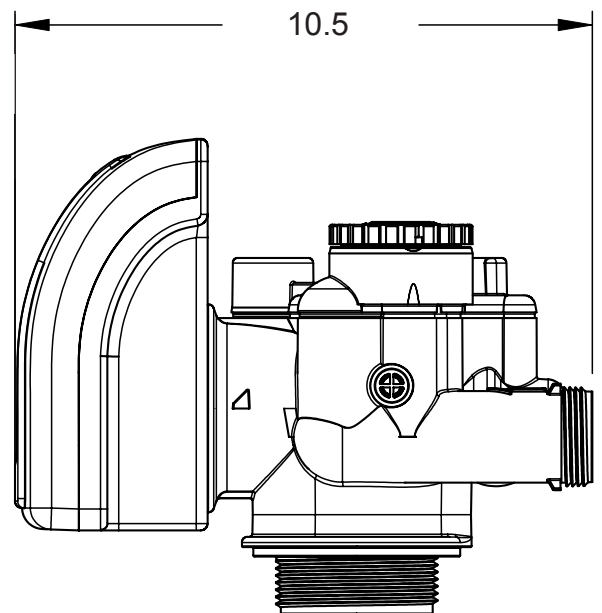
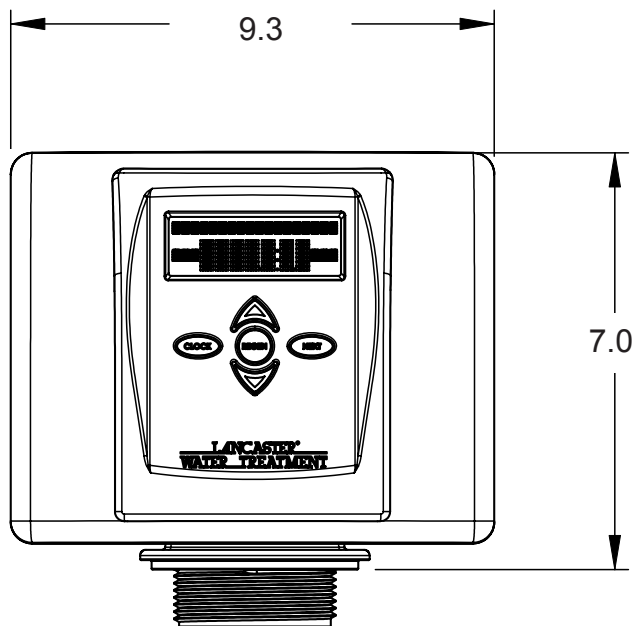

General Notes for estimating only.

X FACTOR SERIES LX SPECIFICATIONS

MODEL NUMBER	7-LX-75B	7-LX-100B	7-LX-150B	7-LX-200B	7-LX-300B
Service Flow (GPM) at 15 PSI Pressure Drop	13	17	16	18	19
Resin Tank Size; Diameter x Height (inches)	8 x 44	10 x 40	10 x 54	12 x 48	14 x 65
Resin; Cu. Ft.	0.75	1	1.5	2	3
Brine Tank Size; (inches)	15 x 17 x 36	15 x 17 x 36	15 x 17 x 36	15 x 17 x 36	18 x 40
Brine Tank Capacity; Lbs NaCl	275	275	275	275	450
Drain Line Flow Control; GPM	1.0	1.7	1.7	2.7	4.2
Brine Line (Re-Fill)Flow Control; GPM	0.5	0.5	0.5	0.5	0.5
Injector; color	1C - Violet	1E - White	1E - White	1F - Blue	1H - Green

X FACTOR SERIES LXC SPECIFICATIONS

MODEL NUMBER	7-LXC-50B (PACKED BED)	7-LXC-75B	7-LXC-100B (PACKED BED)
Service Flow (GPM) at 15 PSI Pressure Drop	14	18	17
Resin Tank Size; Diameter x Height (inches)	9 x 18	10 x 35	10 x 35
Resin; Cu. Ft.	0.5	0.75	1
Cabinet Size (including top cover); W" x L" x H"	13.5 x 22.5 x 27.25	13.5 x 22.5 x 44	13.5 x 22.5 x 44
Cabinet Capacity (with grid); Lbs NaCl	75	225	225
Drain Line Flow Control; GPM	0.7	1.7	1.7
Brine Line (Re-Fill) Flow Control; GPM	0.5	0.5	0.5
Injector; color	1D - Red	1E - White	1E - White

X FACTOR SERIES LX SPECIFICATIONS

MODEL NUMBER		7-LX-75B	7-LX-100B	7-LX-150B	7-LX-200B	7-LX-300B
CYCLES* (Downflow Regenerant, Prefill)						
1st: Fill; Lbs NaCl		6.0	8.0	12.0	16.0	24.0
2nd: Softening; Minutes (Regenerant Production)		60	60	60	60	60
3rd: Backwash; Minutes		10	10	10	10	10
4th: Regenerant Draw DN; Minutes (Draw & Slow Rinse)		50	50	50	50	50
5th: Backwash; Minutes		10	10	10	10	10
6th: Rinse; Minutes (Fast Rinse)		5	5	5	5	5
7th: End		-	-	-	-	-
GRAINS CAPACITY	Low	12,750	17,000	25,500	34,000	51,000
	Medium*	18,000	24,000	36,000	48,000	72,000
	High	24,000	32,000	48,000	64,000	96,000
LBS NaCl Per Regeneration	Low	3.4	4.5	6.75	9.0	13.5
	Medium*	6.0	8.0	12.0	16.0	24.0
	High	11.3	15.0	22.5	30.0	45.0
(Re-) FILL Minutes	Low	2.3	3.0	4.5	6.0	9.0
	Medium*	4.0	5.3	8.0	10.7	16.0
	High	7.5	10.0	15.0	20.0	30.0
GALLONS ¹ WATER TO DRAIN at 40/50/60 PSI Inlet Pressure	Low	38.4/39.6/40.4	60.8/62.5/63.8	61.5/63.3/64.5	94.5/96.3/98.0	142.5/145.5/148.0
	Medium*	39.3/40.5/41.3	61.9/63.7/64.9	63.3/65.0/66.3	96.8/98.6/100.3	146.0/149.0/151.5
	High	41.0/42.3/43.0	64.3/66.0/67.3	66.8/68.5/69.8	101.5/103.3/105.0	153.0/156.0/158.5
WATER ² USAGE % Efficiency at 10 GRAINS per GALLON and 40 PSI Inlet Pressure	Low	97.1	96.5	97.6	97.3	97.3
	Medium*	97.9	97.5	98.3	98.0	98.0
	High	98.3	98.0	98.6	98.4	98.4

* Factory Setting.

¹ Gallons to Drain = (Backwash Min. x DLFC Gal./Min.) + (Fast Rinse Min. x DLFC Gal./Min.) + (Regenerant Draw DN Min. x Slow Rinse Gal./Min.) + (LBS. NaCl x 1 Gal./3 LBS. NaCl)

Note: Slow Rinse Gal./Min. is obtained from injector charts for each color injector at various pressures.

² Water Usage % Efficiency = $\frac{\text{Gallons Treated}}{\text{Gallons Treated} + \text{Gallons to Drain}} \times 100$

X FACTOR SERIES LXC SPECIFICATIONS

MODEL NUMBER		7-LXC-50B (PACKED BED)	7-LXC-75B	7-LXC-100B (PACKED BED)
CYCLES* (Downflow Regenerant, Prefill)				
1st: Fill; Lbs NaCl		4.0	6.0	8.0
2nd: Softening; Minutes (Regenerant Production)		60	60	60
3rd: Backwash; Minutes		NA	10	NA
4th: Regenerant Draw DN; Minutes (Draw & Slow Rinse)		50	50	50
5th: Backwash; Minutes		NA	10	NA
6th: Rinse; Minutes (Fast Rinse)		5	5	5
7th: End		-	-	-
GRAINS CAPACITY	Low	8,500	12,750	17,000
	Medium*	12,000	18,000	24,000
	High	16,000	24,000	32,000
LBS NaCl Per Regeneration	Low	2.3	3.4	4.5
	Medium*	4.0	6.0	8.0
	High	7.5	11.3	15.0
(Re-) FILL Minutes	Low	1.5	2.3	3.0
	Medium*	2.7	4.0	5.3
	High	5.0	7.5	10.0
GALLONS ¹ WATER TO DRAIN at 40/50/60 PSI Inlet Pressure	Low	18.5/20.0/21.3	60.4/62.1/63.4	26.8/28.5/29.8
	Medium*	19.0/20.6/21.8	61.2/63.0/64.2	27.9/29.7/30.9
	High	20.3/21.8/23.0	63.1/64.8/66.1	30.3/32.0/33.3
WATER ² USAGE % Efficiency at 10 GRAINS per GALLON and 40 PSI Inlet Pressure	Low	97.9	95.5	98.4
	Medium*	98.4	96.7	98.9
	High	98.8	97.4	99.1

* Factory Setting.

¹ Gallons to Drain = (Backwash Min. x DLFC Gal./Min.) + (Fast Rinse Min. x DLFC Gal./Min.) + (Regenerant Draw DN Min. x Slow Rinse Gal./Min.) + (LBS. NaCl x 1 Gal./3 LBS. NaCl)

Note: Slow Rinse Gal./Min. is obtained from injector charts for each color injector at various pressures.

² Water Usage % Efficiency = $\frac{\text{Gallons Treated}}{\text{Gallons Treated} + \text{Gallons to Drain}} \times 100$

SOFTENER ASSEMBLY

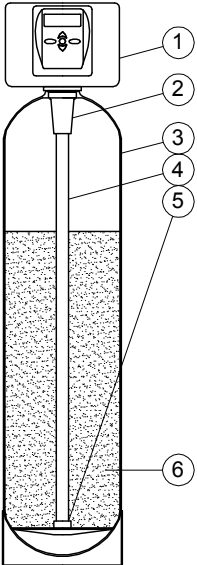

Dwg. No.	Order No.	Description	Qty
1	LXCV1 (detailed components shown in this manual)	Metered Control Valve	1
2	D1203	Top Distributor	1
3,4,5	FG844VT, D1130-12 Ft. (cut for 44 in.), R-DIP1050	Tank, Pipe, Connector, Assy for Model 7-LX-75B	1
	FG1040VT, D1130-12 Ft. (cut for 40 in.), R-DIP1050	Tank, Pipe, Connector, Assy for Model 7-LX-100B	1
	FG1054VT, D1130-12 Ft. (cut for 54 in.), R-DIP1050	Tank, Pipe, Connector, Assy for Model 7-LX-150B	1
	FG1248VT, D1130-12 Ft. (cut for 48 in.), R-DIP1050	Tank, Pipe, Connector, Assy for Model 7-LX-200B	1
	FG1465VT, D1130-12 Ft. (cut for 65 in.), R-DIP1050	Tank, Pipe, Connector, Assy for Model 7-LX-300B	1
6	A4074 (3/4 Cu. Ft. = 39 LBS)	Ion Exchange Resin for Model 7-LX-75B	1
	A4074 (1 Cu. Ft. = 52 LBS)	Ion Exchange Resin for Model 7-LX-100B	1
	A4074 (1 1/2 Cu. Ft. = 78 LBS)	Ion Exchange Resin for Model 7-LX-150B	1
	A4074 (2 Cu. Ft. = 104 LBS)	Ion Exchange Resin for Model 7-LX-200B	1
	A4074 (3 Cu. Ft. = 156 LBS)	Ion Exchange Resin for Model 7-LX-300B	1

BRINE TANK ASSEMBLY

Dwg. No.	Order No.	Description	Qty
1	J7952	15x17x36 Assembly for Model 7-LX-75B, -100B, -150B, -200B	1
	G2136	18x40 Brine Tank with Cover for Model 7-LX-300B	1
2	H1031	4x30 Slotted Brine Well for Model 7-LX-75B, -100B, -150B, -200B	1
	H1036	4x36 Slotted Brine Well for Model 7-LX-300B	1
3	H7016	4 inch Brine Well Cap for Model 7-LX-75B, -100B, -150B, -200B	2
		(Top Cap Only for Models 7-LX-300B)	(1)
4	4740 4740-L	3/8" Brine Valve Assembly (using 1/2"x25" long air check assy for Model 7-LX-75B, -100B, -150B, -200B) (using 1/2"x43" long air check assy for Model 7-LX-300B)	1
5	H1018	Two Piece Overflow Set	1
6	1640N	Nylon Screw (only for Model 7-LX-300B)	1
	6785N	Nylon Nut (only for Model 7-LX-300B)	1
7	H1023	3/8"O.D.x6 Ft. Poly Tubing	1

L56-40A 18 x 40
Brine Tank Assy.

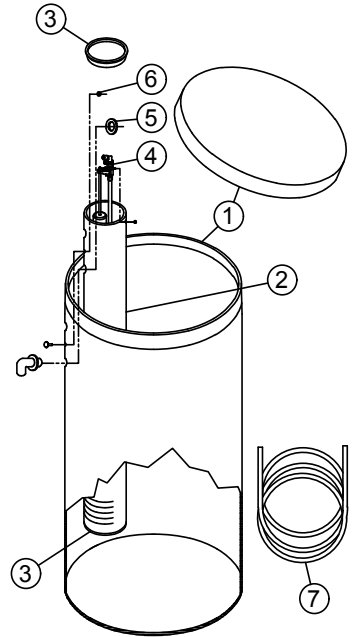

4740 BRINE VALVE ASSEMBLY

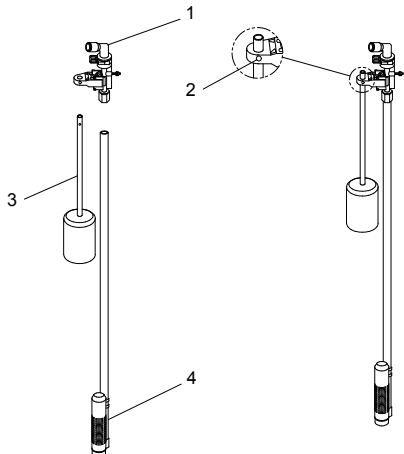

Dwg No.	Order No.	Description	Qty
1	H4600	3/8" Safety Brine Valve	1
2	10151	Pin	1
3	H4640-9.5	Float Assembly	1
4	H4500-48	Air Check Assembly (uncut length) see brine tank assy for cut length	1

J7952 15 x 17 x 36
Brine Tank Assy.

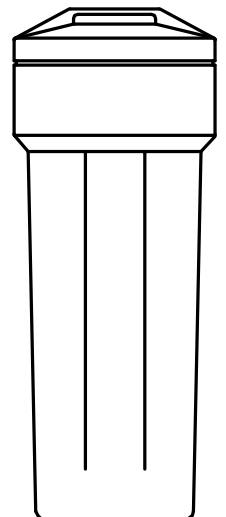

X-FACTOR FRONT COVER AND DRIVE ASSEMBLY

Drawing No.	Order No.	Description	Quantity
1	V3692-02LW	LP Front Cover Assembly	1
2	V3107-01	Motor	1
3	V3106-01	Drive Bracket, Spring Clip, Drive Gear 12x36 and Drive Gear Cover	1
4	V3757LP	PC Board	1

When replacing the battery, align positives and push down to fully seat.

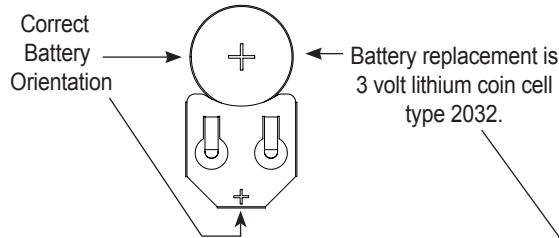
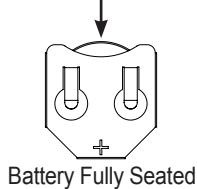

AC Adapter	(Not shown)
Order No.	V3186
Supply Voltage	120V AC
Supply Frequency	60 Hz
Output Voltage	12V AC
Output Current	500 mA
No user serviceable parts are on the PC board, the motor, or the power adapter. The means of disconnection from the main power supply is by unplugging the power adapter from the wall.	

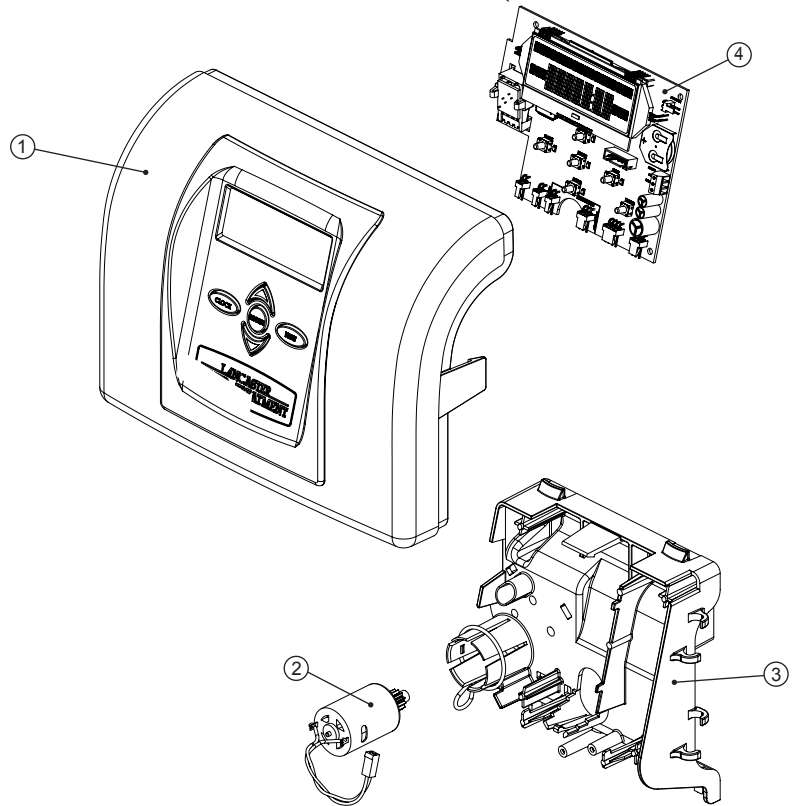

After completing any valve maintenance involving the drive assembly or the drive cap assembly and pistons, unplug power source jack from the printed circuit board (black wire) and plug back in or press and hold **NEXT** and **REGEN** buttons for 3 seconds. This resets the electronics and establishes the service piston position. The display should flash the software version and then reset the valve to the service position.

DRIVE CAP ASSEMBLY, DOWNFLOW PISTON, REGENERANT PISTON AND SPACER STACK ASSEMBLY

Drawing No.	Order No.	Description	Qty
1	V3005	Spacer Stack Assembly	1
2	V3004	Drive Cap Assy	1
3	V3178LP	Back Plate	1
4	V3011	Piston Downflow Assy	1
5	V3174	Regenerant Piston	1
6	V3135	O-ring 228	1
7	V3180	O-ring 337	1
8	V3105	O-ring 215 (Distributor Tube)	1
Not Shown	V3001	Body Assy Downflow	1

Do not use Vaseline, oils, other hydrocarbon lubricants or spray silicone anywhere. A silicone lubricant may be used on black o-rings but is not necessary. **Avoid any type of lubricants, including silicone, on the clear lip seals.**

After completing any valve maintenance involving the drive assembly or the drive cap assembly and pistons, unplug power source jack from the printed circuit board (black wire) and plug back in or press and hold **NEXT** and **REGEN** buttons for 3 seconds. This resets the electronics and establishes the service piston position. The display should flash the software version and then reset the valve to the service position.

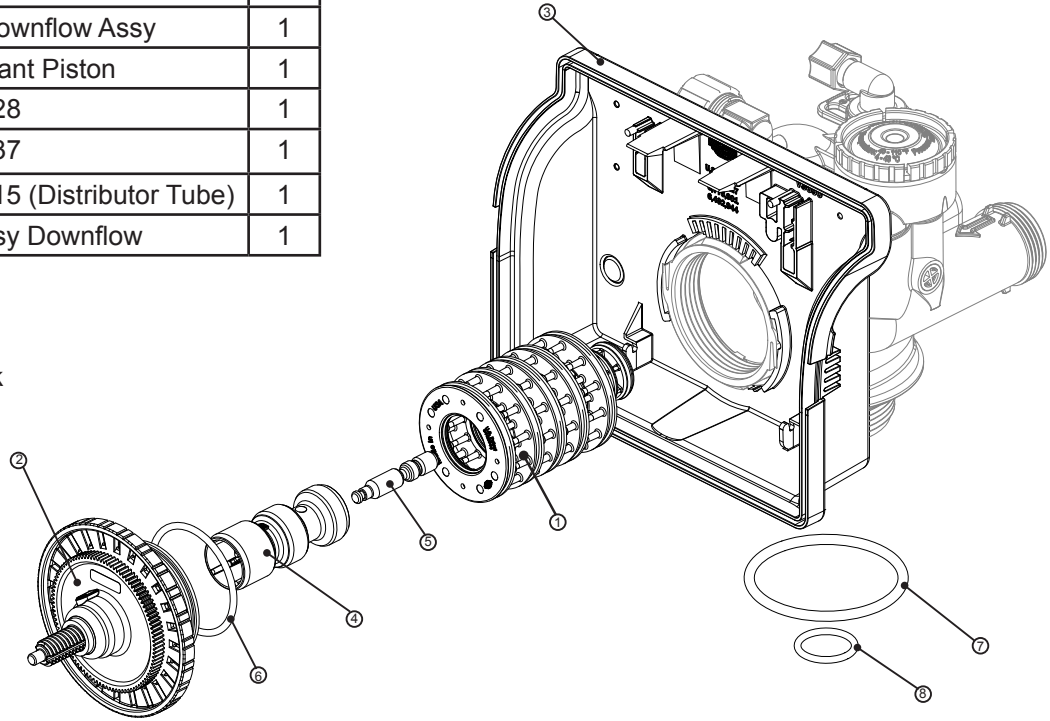

INJECTOR CAP, INJECTOR SCREEN, INJECTOR, PLUG AND O-RING

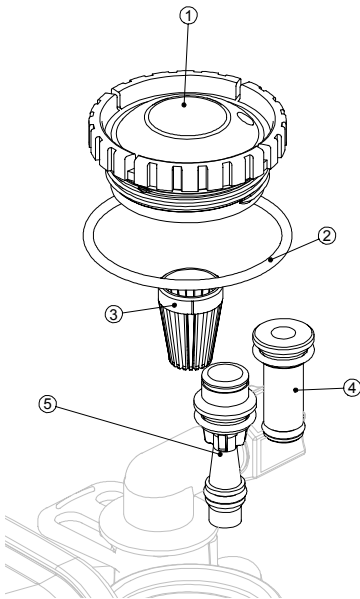

Drawing No.	Order No.	Description	Qty
1	V3176	INJECTOR CAP	1
2	V3152	O-RING 135	1
3	V3177-01	INJECTOR SCREEN CAGE	1
4	V3010-1Z	INJECTOR ASSY Z PLUG	1
5	V3010-1A	INJECTOR ASSY A BLACK	1
	V3010-1B	INJECTOR ASSY B BROWN	
	V3010-1C	INJECTOR ASSY C VIOLET	
	V3010-1D	INJECTOR ASSY D RED	
	V3010-1E	INJECTOR ASSY E WHITE	
	V3010-1F	INJECTOR ASSY F BLUE	
	V3010-1G	INJECTOR ASSY G YELLOW	
	V3010-1H	INJECTOR ASSY H GREEN	
	V3010-1I	INJECTOR ASSY I ORANGE	
	V3010-1J	INJECTOR ASSY J LIGHT BLUE	
	V3010-1K	INJECTOR ASSY K LIGHT GREEN	
Not Shown	V3170	O-RING 011	*
Not Shown	V3171	O-RING 013	*

* The injector plug and the injector each contain one 011 (lower) and 013 (upper) o-ring.

The nut and caps are designed to be unscrewed or tightened by hand or with the service spanner wrench (see page 21). If necessary a pliers can be used to unscrew the nut or cap. Do not use a pipe wrench to tighten or loosen nuts or caps. Do not place a screwdriver in slots on caps and/or tap with a hammer.

REFILL FLOW CONTROL ASSEMBLY

Drawing No.	Order No.	Description	Qty
1	H4615	Elbow Locking Clip	1
2	H4628	Elbow 3/8" Liquifit	1
3	V3163	O-ring 019	1
4	V3165-01*	RFC Retainer Assy (0.5 gpm)	1
5	V3182	RFC	1
6	V4144-01	Elbow 3/8 Liquifit Assy w/RFC	1

*Assembly includes V3182 RFC.

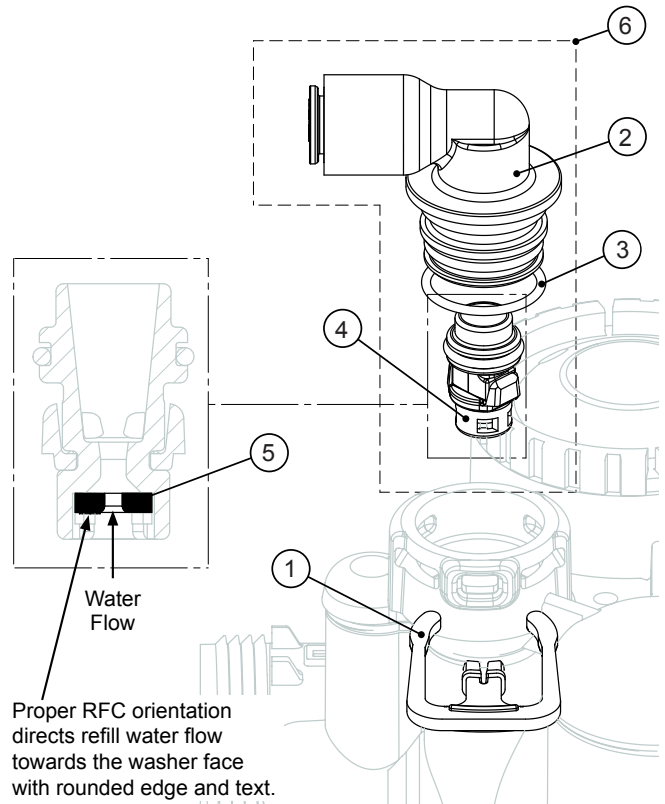

WATER METER

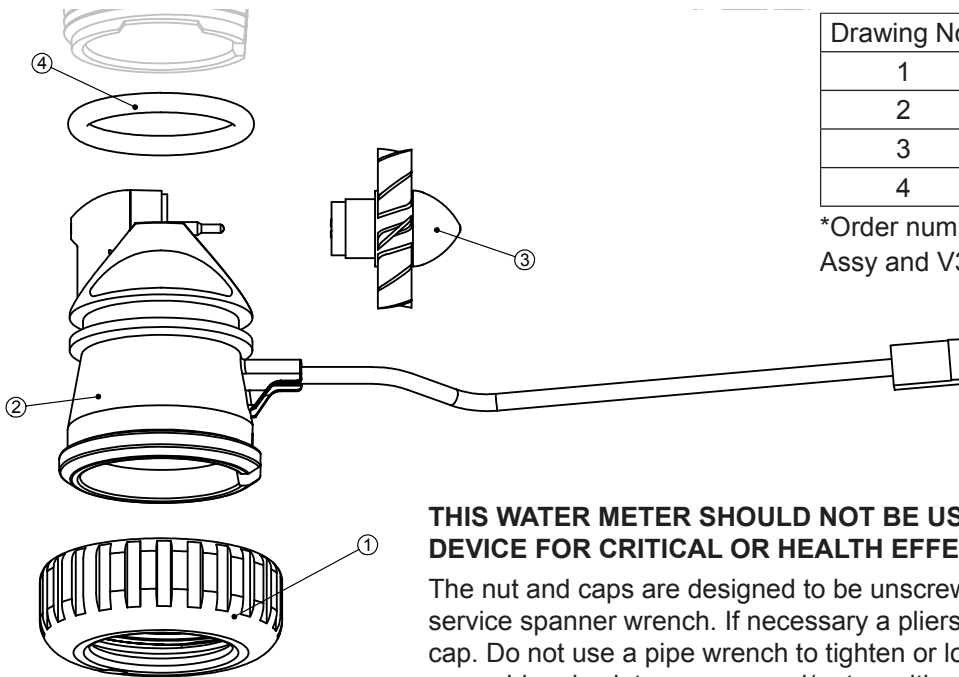

Drawing No.	Order No.	Description	Qty
1	V3151	Nut 1" QC	1
2	V3003*	Meter Assy	1
3	V3118-01	Turbine Assy	1
4	V3105	O-ring 215	1

*Order number V3003 includes V3118-01 Turbine Assy and V3105 O-ring 215.

THIS WATER METER SHOULD NOT BE USED AS THE PRIMARY MONITORING DEVICE FOR CRITICAL OR HEALTH EFFECT APPLICATIONS.

The nut and caps are designed to be unscrewed or tightened by hand or with the service spanner wrench. If necessary a pliers can be used to unscrew the nut or cap. Do not use a pipe wrench to tighten or loosen nuts or caps. Do not place a screwdriver in slots on caps and/or tap with a hammer.

DRAIN LINE - 3/4"

Dwg No.	Order No.	Description	Qty
1	H4615	Elbow Locking Clip	1
2	V3194	Polytube insert 5/8	Option
3	V3192	Nut 3/4 Drain Elbow	Option
4*	V3158	Drain Elbow 3/4 Male	1
5	V3163	O-ring 019	1
6*	V3159	DLFC Retainer Assy	1
7	V3162-007	DLFC 0.7 gpm for 3/4	One DLFC must be used if 3/4 fitting is used
	V3162-010	DLFC 1.0 gpm for 3/4	
	V3162-013	DLFC 1.3 gpm for 3/4	
	V3162-017	DLFC 1.7 gpm for 3/4	
	V3162-022	DLFC 2.2 gpm for 3/4	
	V3162-027	DLFC 2.7 gpm for 3/4	
	V3162-032	DLFC 3.2 gpm for 3/4	
	V3162-042	DLFC 4.2 gpm for 3/4	
	V3162-053	DLFC 5.3 gpm for 3/4	
	V3162-065	DLFC 6.5 gpm for 3/4	
V3162-075	DLFC 7.5 gpm for 3/4		
V3162-090	DLFC 9.0 gpm for 3/4		
V3162-100	DLFC 10.0 gpm for 3/4		

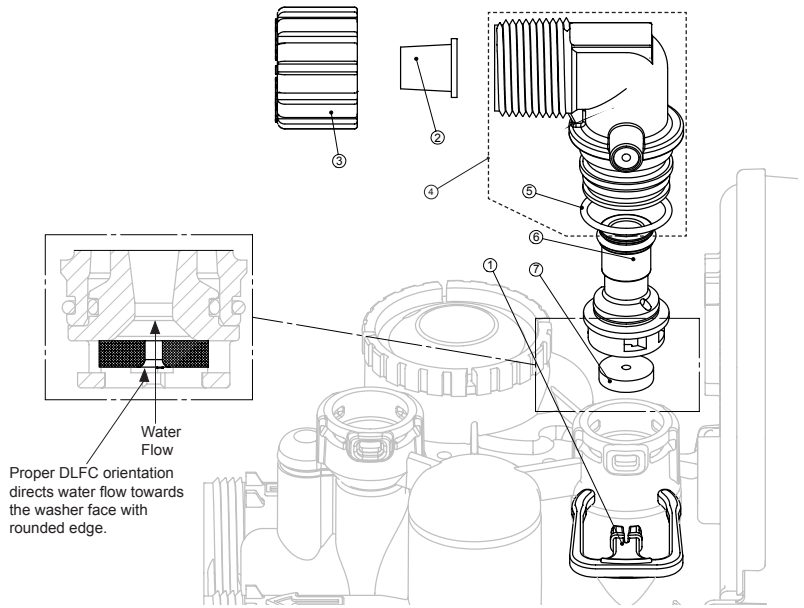

*4 and 6 can be ordered as a complete assembly - V3331 Drain Elbow and Retainer Assy

Do not use pipe dope or other sealants on threads. Teflon tape must be used on threads of 3/4" NPT connection (unless using 5/8" polytubing).

Do not use Vaseline, oils, other hydrocarbon lubricants or spray silicone anywhere. A silicone lubricant may be used on black o-rings but is not necessary.

INSTALLATION FITTING ASSEMBLIES

Order No: **V3007** (Standard)
Description: **Fitting 1" PVC Male NPT Elbow Assembly**

Drawing No.	Order No.	Description	Quantity
1	V3151	Nut 1" Quick Connect	2
2	V3150	Split Ring	2
3	V3105	O-Ring 215	2
4	V3149	Fitting 1 PVC Male NPT Elbow	2

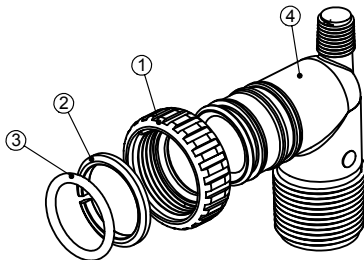

Order No. **V3191-01** (Optional)
Description: **Fitting Vertical Adapter Assembly**

Drawing No.	Order No.	Description	Quantity
1	V3151	Nut 1" Quick Connect	2
2	V3150	Split Ring	2
3	V3105	O-Ring 215	2
4	V3191	Vertical Adapter	2

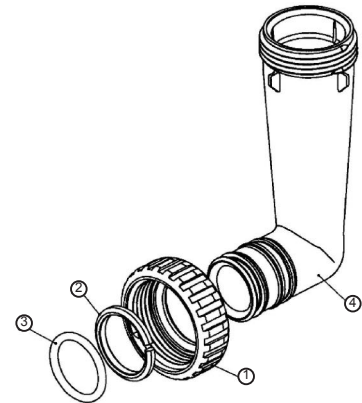

Do not use pipe dope or other sealants on threads. Teflon tape must be used on threads of 1" NPT connection. Teflon tape is not necessary on the nut connection nor caps because of o-ring seals.

The nut and caps are designed to be unscrewed or tightened by hand or with the service spanner wrench. If necessary a pliers can be used to unscrew the nut or cap. Do not use a pipe wrench to tighten or loosen nuts or caps. Do not place a screwdriver in slots on caps and/or tap with a hammer.

Do not use Vaseline, oils, other hydrocarbon lubricants or spray silicone anywhere. A silicone lubricant may be used on black o-rings but is not necessary.

BYPASS VALVE

(Order No. BP2000)

Drawing No.	Order No.	Description	Qty
1	V3151	Nut 1" Quick Connect	2
2	V3150	Split Ring	2
3	V3105	O-Ring 215	2
4	V3145	Bypass 1" Rotor	2
5	V3146	Bypass Cap	2
6	V3147	Bypass Handle	2
7	V3148	Bypass Rotor Seal Retainer	2
8	V3152	O-ring 135	2
9	V3155	O-ring 112	2
10	V3156	O-ring 214	2

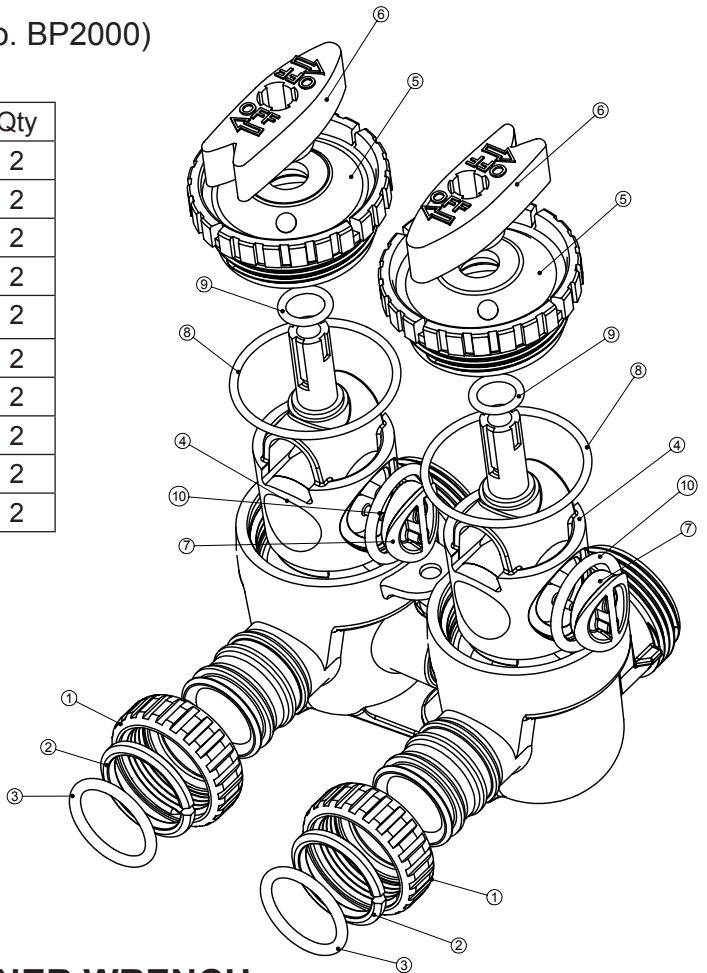

SERVICE SPANNER WRENCH

(Order No. V3193)

Although no tools are necessary to assemble or disassemble the valve, the wrench (shown in various positions on the valve) may be purchased to aid in assembly or disassembly.

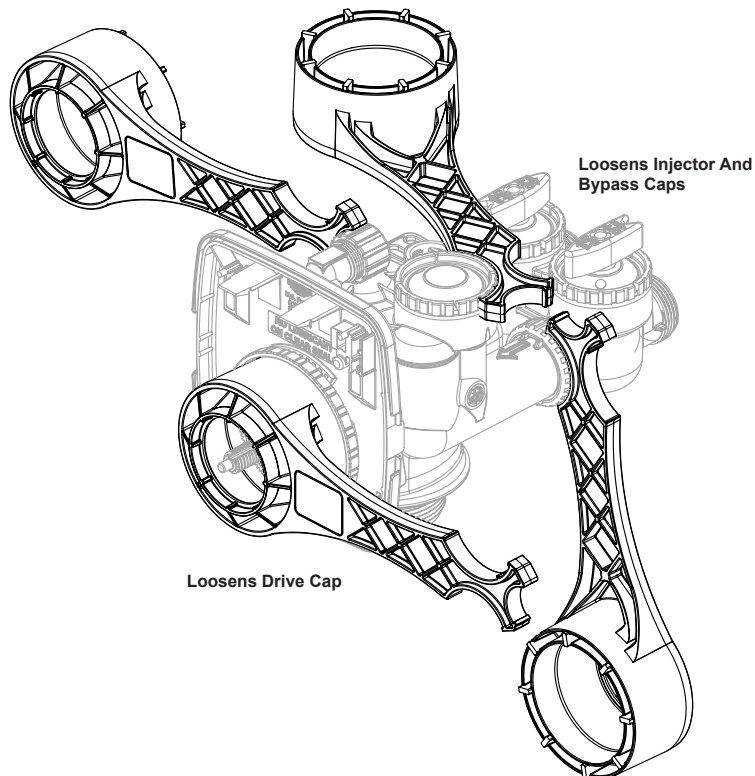

OPTIONAL INSTALLATION FITTING ASSEMBLIES

Order No: **V3007-01**
Description: **Fitting ¾" & 1" PVC Solvent 90° Assembly**

Drawing No.	Order No.	Description	Quantity
1	V3151	Nut 1" Quick Connect	2
2	V3150	Split Ring	2
3	V3105	O-Ring 215	2
4	V3189	Fitting ¾"&1" PVC Solvent 90	2

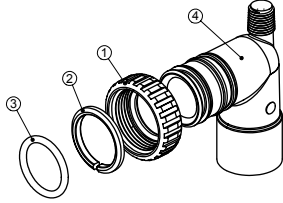

Order No: **V3007-02**
Description: **Fitting 1" Brass Sweat Assembly**

Drawing No.	Order No.	Description	Quantity
1	V3151	Nut 1" Quick Connect	2
2	V3150	Split Ring	2
3	V3105	O-Ring 215	2
4	V3188	Fitting 1 Brass Sweat Assembly	2

Do not install in California.

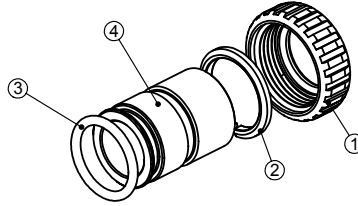

Order No: **V3007-03**
Description: **Fitting ¾" Brass Sweat Assembly**

Drawing No.	Order No.	Description	Quantity
1	V3151	Nut 1" Quick Connect	2
2	V3150	Split Ring	2
3	V3105	O-Ring 215	2
4	V3188-01	Fitting ¾" Brass Sweat	2

Do not install in California.

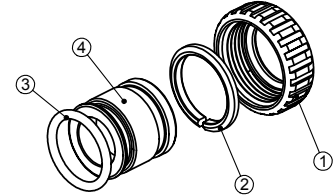

Order No: **V3007-04**
Description: **Fitting 1" Plastic Male NPT Assembly**

Drawing No.	Order No.	Description	Quantity
1	V3151	Nut 1" Quick Connect	2
2	V3150	Split Ring	2
3	V3105	O-Ring 215	2
4	V3164	Fitting 1" Plastic Male NPT	2

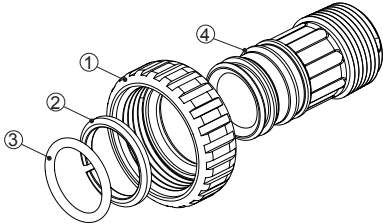

Order No: **V3007-05**
Description: **Fitting 1-¼" Plastic Male NPT Assembly**

Drawing No.	Order No.	Description	Quantity
1	V3151	Nut 1" Quick Connect	2
2	V3150	Split Ring	2
3	V3105	O-Ring 215	2
4	V3317	Fitting 1-¼" Plastic Male NPT	2

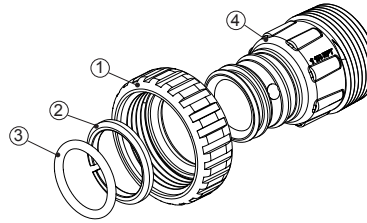

Order No: **V3007-07**
Description: **Fitting 1¼" & 1½" PVC Solvent Assembly**

Drawing No.	Order No.	Description	Quantity
1	V3151	Nut 1" Quick Connect	2
2	V3150	Split Ring	2
3	V3105	O-Ring 215	2
4	V3352	Fitting 1¼"&1½" PVC Solvent	2

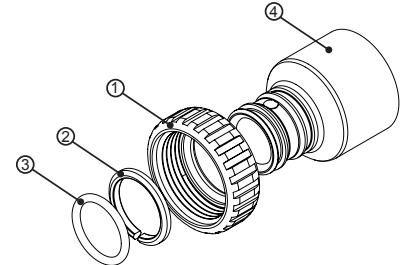

Order No: **V3007-09**
Description: **Fitting 1¼" & 1½" Brass Sweat Assembly**

Drawing No.	Order No.	Description	Quantity
1	V3151	Nut 1" Quick Connect	2
2	V3150	Split Ring	2
3	V3105	O-Ring 215	2
4	V3375	Fitting 1¼" & 1½" Brass Sweat	2

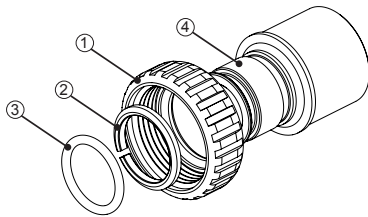

Order No: **V3007-12**
Description: **Fitting ¾" Brass SharkBite Assembly**

Drawing No.	Order No.	Description	Quantity
1	V3151	Nut 1" Quick Connect	2
2	V3150	Split Ring	2
3	V3105	O-Ring 215	2
4	V3628	Ftg ¾" Brass Shark-Bite	2

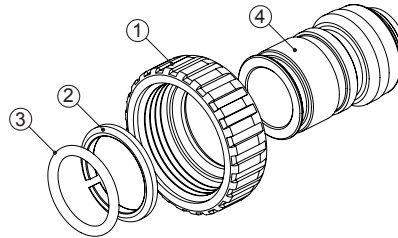

Order No: **V3007-13**
Description: **Fitting 1" Brass SharkBite Assembly**

Drawing No.	Order No.	Description	Quantity
1	V3151	Nut 1" Quick Connect	2
2	V3150	Split Ring	2
3	V3105	O-Ring 215	2
4	V3629	Ftg 1" Brass Shark-Bite	2

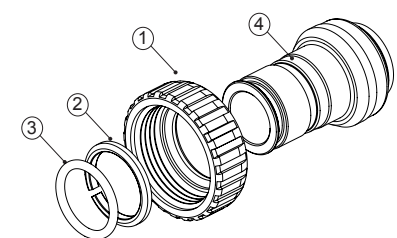

Order No: **V3007-15**
Description: **WS1 FTG ¾" JG QC 90 ASY**

Drawing No.	Order No.	Description	Quantity
1	V3151	WS1 NUT 1 QC	2
2	V3150	WS1 SPLIT RING	2
3	V3105	O-RING 215	2
4	V3790	WS1 ELBOW ¾" QC W/STEM	2

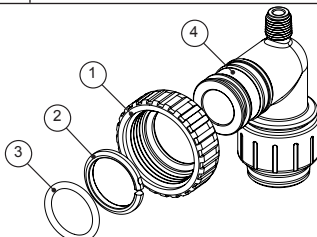

Order No: **V3007-17**
Description: **WS1 FTG 1" JG QC ASY**

Drawing No.	Order No.	Description	Quantity
1	V3105	O-RING 215	2
2	V3150	WS1 SPLIT RING	2
3	V3151	WS1 NUT 1 QC	2
4	V4045	WS1 FTG 1" INCH QC	2

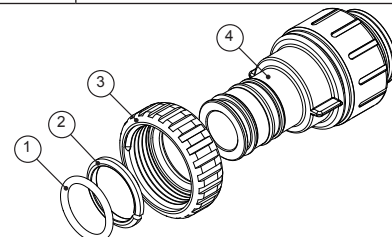

CABINET SOFTENER ASSEMBLY

Order No.	Description
G2700T, G2718B	Cabinet, Top Cover for Model 7-LXC-50B
G2700T, G2735B	Cabinet, Top Cover for Model 7-LXC-75B, -100B
LXCV1 (detailed components shown in this manual)	Metered Control Valve
D1203	Top Distributor
FG918VT, D1130-12 Ft. (cut for 18 in.), R-DIP1050	Tank, Pipe, Connector, Assy for Model 7-LXC-50B
FG1035VT, D1130-12 Ft. (cut for 35 in.), R-DIP1050	Tank, Pipe, Connector, Assy for Model 7-LXC-75B, -100B
A4074 (1/2 Cu. Ft. = 26 LBS)	Ion Exchange Resin for Model 7-LXC-50B
A4074 (3/4 Cu. Ft. = 39 LBS)	Ion Exchange Resin for Model 7-LXC-75B
A4074 (1 Cu. Ft. = 52 LBS)	Ion Exchange Resin for Model 7-LXC-100B

7-LXC-50B MINI CABINET

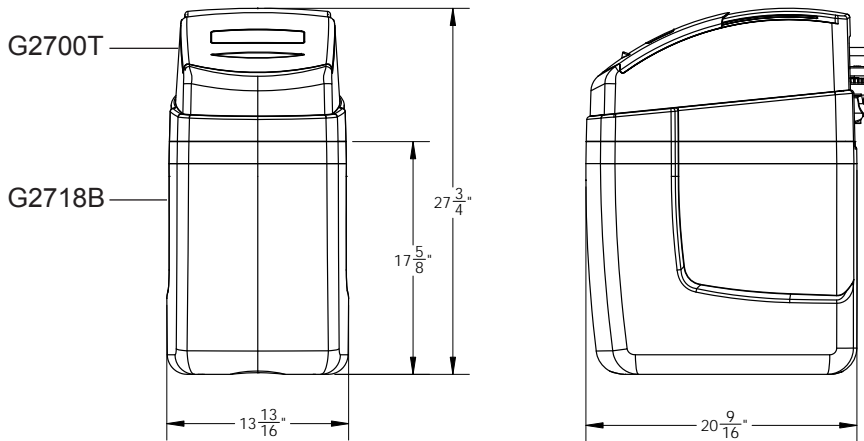

7-LXC-75B, 7-LXC-100B CABINET

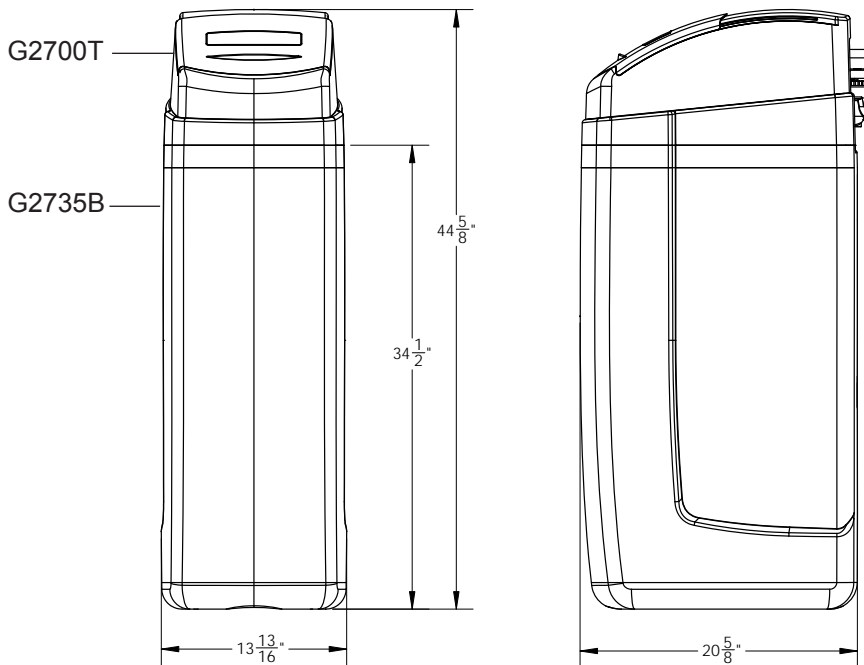

SERVICE INSTRUCTIONS



When servicing the valve, water may leak from the valve. Water from the valve may create a slip hazard. Clean up water spills.

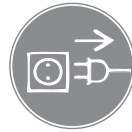

Disconnect from electrical power prior to servicing the valve.

DRIVE ASSEMBLY:

Remove the valve cover to access the drive assembly.

Disconnect the power source plug (black wire) from the PC board prior to disconnecting the motor or water meter plugs from the PC board. The power source plug connects to the four-pin jack. The motor plug connects to the two-pin jack on the left-hand side of the PC board. The water meter plug (gray wire) connects to the three-pin jack on the far right-hand side of the PC board.

The PC board can be removed separately from the drive bracket but it is not recommended. Do not attempt to remove the display panel from the PC board. Handle the board by the edges. To remove the PC board from the drive bracket, unplug the power, water meter and motor plugs from the PC board. Lift the middle latch along the top of the drive bracket while pulling outward on the top of the PC board. The drive bracket has two plastic pins that fit into the holes on the lower edge of the PC board. Once the PC board is tilted about 45° from the drive bracket it can be lifted off of these pins. To reinstall the PC board, position the lower edge of the PC board so that the holes in the PC board line up with the plastic pins. Push the top of the PC board towards the valve until it snaps under the middle latch, weave the power and water meter wires into the holders and reconnect the motor, water meter and power plugs.

The drive bracket must be removed to access the drive cap assembly and pistons or the drive gear cover. It is not necessary to remove the PC board from the drive bracket to remove the drive bracket. To remove the drive bracket start by removing the plugs for the power source and the water meter. Unweave the wires from the side holders. Two tabs on the top of the drive back plate hold the drive bracket in place. Simultaneously lift the two tabs and gently ease the top of the drive bracket forward. The lower edge of the drive bracket has two notches that rest on the drive back plate. Lift up and outward on the drive bracket to disengage the notches.

To reassemble, seat the bottom of the drive bracket so the notches are engaged at the bottom of the drive back plate. Push the top of the drive bracket toward the two latches. The drive bracket may have to be lifted slightly to let the threaded piston rod pass through the hole in the drive bracket. Maintain a slight engaging force on top of the drive bracket while deflecting the bracket slightly to the left by pressing on the side of the upper right corner. This helps the drive gears mesh with the drive cap assembly. The drive bracket is properly seated when it snaps under the latches on the drive back plate. If resistance is felt before latching, then notches are not fully engaged, the piston rod is not in hole, the wires are jammed between the drive bracket and drive back plate, or the gear is not engaging the drive cap assembly.

To inspect the drive gears, the drive gear cover needs to be removed. Before trying to remove the gear cover, the drive bracket must be removed from the drive back plate. (Refer to the instructions above regarding removing the drive bracket from the drive back plate. The drive gear cover can be removed from the drive bracket without removing the motor or the PC board.) The drive gear cover is held in place on the drive bracket by three clips. The largest of the three clips is always orientated to the bottom of the drive bracket. With the PC board facing up, push in and down on the large clip on the drive gear cover. Handle the cover and the gears carefully so that the gears do not fall off the pegs in the cover.

Replace broken or damaged drive gears. Do not lubricate any of the gears. Avoid getting any foreign matter on the reflective coating because dirt or oils may interfere with pulse counting.

The drive gear cover only fits on one way, with the large clip orientated towards the bottom. If all three clips are outside of the gear shroud on the drive bracket the drive gear cover slips easily into place.

The drive bracket does not need to be removed from the drive plate if the motor needs to be removed. To remove the motor, disconnect the power and motor plugs from the jacks on the PC board. Move the spring clip loop to the right and hold. Rotate the motor at least a ¼ turn in either direction so the wires are vertical (up & down) before gently pulling on the wire connectors to remove the motor. Pulling directly on the wires without rotating the motor may break the wires off the motor.

Replace the motor if necessary. Do not lubricate the motor or the gears. To reinstall the motor, move the spring clip loop to the right and hold. Gently turn the motor while inserting so that the gear on the motor meshes with the gears under the drive gear cover. Release the spring clip loop and continue to rotate the motor until the wires are horizontal and the motor housing engages the small plastic bulge inside the drive bracket motor retainer. Reconnect the motor plug to the two-pronged jack on the lower left side of the PC board. If the motor will not easily engage with the drive gears when reinstalling, lift and slightly rotate the motor before reinserting. Reconnect the power plug.

Replace the valve cover. After completing any valve maintenance involving the drive assembly or the drive cap assembly and pistons unplug power source jack from the printed circuit board (black wire) and plug back in or press and hold NEXT and REGEN buttons for 3 seconds.

This resets the electronics and establishes the service piston position. The display should flash all wording, then flash the software version and then reset the valve to the service position.

DRIVE CAP ASSEMBLY, MAIN PISTON AND REGENERANT PISTON:

The drive assembly must be removed to access the drive cap assembly. The drive cap assembly must be removed to access the piston(s). The drive cap assembly is threaded into the control valve body and seals with an o-ring. To remove the drive cap assembly use the special plastic wrench or insert a ¼" to ½" flat blade screwdriver into one of the slots around the top 2" of the drive cap assembly so it engages the notches molded into the drive back plate around the top 2" of the piston cavity. See below. The notches are visible through the holes. Lever the screwdriver so the drive cap assembly turns counter clockwise. Once loosened unscrew the drive cap assembly by hand and pull straight out.

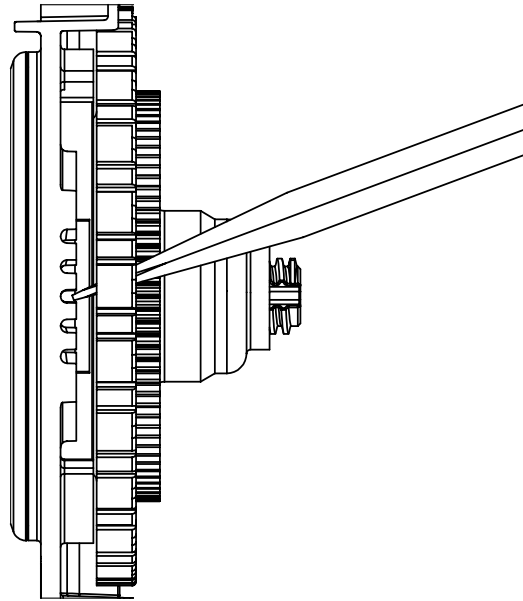

The drive cap assembly contains the drive cap, the main drive gear, drive cap spline, piston rod and various other parts that should not be disassembled in the field. The only replaceable part on the drive cap assembly is the o-ring. Attached to the drive cap assembly is the main piston and if a regenerant is used, a regenerant piston.

The regenerant piston (the small diameter one behind the main piston) is removed from the main piston by pressing sideways and unsnapping it from its latch. Chemically clean in dilute sodium bisulfite or vinegar, or replace the regenerant piston if needed. To remove the main piston fully extend the piston rod and then unsnap the main piston from its latch by pressing on the side with the number. Chemically clean in dilute sodium bisulfite or vinegar, or replace the main piston.

Reattach the main piston to the drive cap assembly. Reattach the regenerant piston (if needed) to the main piston. Reinsert the drive cap assembly and piston into the spacer stack assembly and hand tighten the drive cap assembly. Continue to tighten the drive cap assembly using a screwdriver as a ratchet until the black o-ring on the spacer stack assembly is no longer visible through the drain port. Excessive force can break the notches molded into the drive back plate. Make certain that the main drive gear still turns freely.

The exact position of the piston is not important as long as the main drive gear turns freely. Reattach the drive assembly to the control valve and connect all plugs. After completing any valve maintenance involving the drive assembly or the drive cap assembly and pistons unplug power source jack from the printed circuit board (black wire) and plug back in or press and hold NEXT and REGEN buttons for 3 seconds.

This resets the electronics and establishes the service piston position. The display should flash all wording, then flash the software version and then reset the valve to the service position.

REFILL FLOW CONTROL ASSEMBLY:

To clean or replace the refill flow control, pull out the elbow-locking clip and then pull straight up on the elbow. Replace the elbow locking clip in the slot so that it is not misplaced. Twist to remove the white flow control retainer. The flow control can be removed by prying upward through the side slots of the retainer with a small flat blade screwdriver.

Chemically clean the flow control or the white flow control retainer using dilute sodium bisulfite or vinegar. Do not use a wire brush. If necessary, replace the flow control, o-ring on the flow control retainer, or the o-ring on the elbow.

Reseat the flow control so the rounded end is visible in the flow control. Reseat the white flow control retainer by pushing the retainer into the elbow until the o-ring seats. Remove locking clip, push down on elbow to reseat and insert locking clip.

Do not use Vaseline, oils, or other unacceptable lubricants on o-rings. A silicone lubricant may be used on the o-ring on the elbow or the white retainer.

SPACER STACK ASSEMBLY:

To access the spacer stack assembly remove the drive assembly, drive cap assembly and piston. The spacer stack assembly can be removed easily without tools by using thumb and forefinger. Inspect the black o-rings and clear lip seals for wear or damage. Replace the entire stack if necessary. Do not disassemble the stack.

The spacer stack assembly may be chemically cleaned (dilute sodium bisulfite or vinegar) or wiped with a soft cloth.

The spacer stack assembly can be pushed in to the control valve body bore by hand. Since the spacer stack assembly can be compressed it is easier to use a blunt object (5/8" to 1-1/8" in diameter) to push the center of the assembly into the control valve body. The assembly is properly seated when at least four threads are exposed (approximately 5/8"). Do not force the spacer stack assembly in. The control valve body bore interior can be lubricated with silicone to allow for easy insertion of the entire stack.

Reattach the drive cap assembly and piston(s) and the drive assembly.

After completing any valve maintenance involving the drive assembly or the drive cap assembly and pistons unplug power source jack from the printed circuit board (black wire) and plug back in or press and hold NEXT and REGEN buttons for 3 seconds.

This resets the electronics and establishes the service piston position. The display should flash all wording, then flash the software version and then reset the valve to the service position.

INJECTOR CAP, SCREEN, INJECTOR PLUG AND INJECTOR:

Unscrew the injector cap and lift off. Loosen cap with special plastic wrench or pliers if necessary. Attached to the injector cap is a screen. Remove the screen and clean if fouled.

The plug and/or injector can be pried out with a small screwdriver. The plug can be wiped clean. If the plug leaks replace the entire plug. The injector consists of a throat and a nozzle. Chemically clean the injector with vinegar or sodium bisulfite. The holes can be blown out with air. Both pieces have small diameter holes that control the flow rates of water to insure that the proper concentration of regenerant is used. Sharp objects, which can score the plastic, should not be used to clean the injector. Scoring the injector or increasing the diameter of the hole could change the operating parameters of the injector.

Push the plug(s) and/or injectors firmly in place, replace the screen and hand tighten the injector cap.

WATER METER:

The water meter assembly is connected to the PC board by a wire. If the entire water meter assembly is to be replaced, remove the control valve cover and disconnect the power source and water meter plugs from the PC board. Unlatch the drive assembly and lean it forward. Unthread the water meter wire from the side of the drive assembly and through the drive back plate. To reinstall, rethread the water meter wire through the drive back plate and the side of the drive assembly. Reattach the drive assembly and the water meter and power plugs.

THIS WATER METER SHOULD NOT BE USED AS THE PRIMARY MONITORING DEVICE FOR CRITICAL OR HEALTH EFFECT APPLICATIONS.

OPERATING PRESSURES: 20 PSI MINIMUM / 125 PSI MAXIMUM • OPERATING TEMPERATURES: 40°F MINIMUM / 110°F MAXIMUM

If no water meter wire is visible, then a plug is installed, not a water meter.

The water meter wire does not need to be removed from the PC board if the water meter is only being inspected and cleaned. To remove the water meter assembly, unscrew the meter cap on the left side of the control valve. Pliers may be used to unscrew the nut if necessary.

With the nut removed, a slot at the top of the water meter is visible. Twist a flat blade screwdriver in the slot between the control valve body and the meter. When the meter is part way out it is easy to remove the water meter from the housing. Once the water meter is removed from the control valve body, gently pull forward on the turbine to remove it from the shaft. Do not use a wire brush to clean the turbine. Wipe with a clean cloth or chemically clean in dilute sodium bisulfite or vinegar. The turbine can be immersed in the chemical. Do not immerse electronics. If the turbine is scored or damaged or the bearings on the turbine are worn, replace the turbine.

Do not lubricate the turbine shaft. The turbine shaft bearings are prelubricated. Do not use Vaseline, oils, or other unacceptable lubricants on the o-ring. A silicone lubricant may be used on the black o-ring.

Snap the turbine on the shaft and reinsert the water meter into the side slot. Hand tighten the nut. Do not use a pipe wrench to tighten nut.

TROUBLESHOOTING

Problem	Possible Cause	Solution
1. No Display on PC Board	a. No power at electric outlet	a. Repair outlet or use working outlet
	b. Control valve Power Adapter not plugged into outlet or power cord end not connected to PC board connection	b. Plug Power Adapter into outlet or connect power cord end to PC Board connection
	c. Improper power supply	c. Verify proper voltage is being delivered to PC Board
	d. Defective Power Adapter	d. Replace Power Adapter
	e. Defective PC Board	e. Replace PC Board
2. PC Board does not display correct time of day	a. Power Adapter plugged into electric outlet controlled by light switch	a. Use uninterrupted outlet
	b. Tripped breaker switch and/or tripped GFI	b. Reset breaker switch and/ or GFI switch
	c. Power outage	c. Reset time of day. If PC Board has battery back up present the battery may be depleted. See Front Cover and Drive Assembly drawing for instructions.
	d. Defective PC Board	d. Replace PC Board
3. Display does not indicate that water is flowing. Refer to user instructions for how the display indicates water is flowing	a. Bypass valve in bypass position	a. Turn bypass handles to place bypass in service position
	b. Meter is not connected to meter connection on PC Board	b. Connect meter to three pin connection labeled METER on PC Board
	c. Restricted/ stalled meter turbine	c. Remove meter and check for rotation or foreign material
	d. Meter wire not installed securely into three pin connector	d. Verify meter cable wires are installed securely into three pin connector labeled METER
	e. Defective meter	e. Replace meter
	f. Defective PC Board	f. Replace PC Board
4. Control valve regenerates at wrong time of day	a. Power outage	a. Reset time of day. If PC Board has battery back up present the battery may be depleted. See Front Cover and Drive Assembly drawing for instructions.
	b. Time of day not set correctly	b. Reset to correct time of day
	c. Time of regeneration set incorrectly	c. Reset regeneration time
	d. Control valve set at "on 0" (immediate regeneration)	d. Check programming setting and reset to NORMAL (for a delayed regen time)
	e. Control valve set at "NORMAL + on 0" (delayed and/ or immediate)	e. Check programming setting and reset to NORMAL (for a delayed regen time)
5. Time of day flashes on and off	a. Power outage	a. Reset time of day. If PC Board has battery back up present the battery may be depleted. See Front Cover and Drive Assembly drawing for instructions.
6. Control valve does not regenerate automatically when the REGEN button	a. Broken drive gear or drive cap assembly	a. Replace drive gear or drive cap assembly
	b. Broken Piston Rod	b. Replace piston rod
	c. Defective PC Board	c. Defective PC Board
7. Control valve does not regenerate automatically but does when the REGEN button	a. Bypass valve in bypass position	a. Turn bypass handles to place bypass in service position
	b. Meter is not connected to meter connection on PC Board	b. Connect meter to three pin connection labeled METER on PC Board
	c. Restricted/ stalled meter turbine	c. Remove meter and check for rotation or foreign material
	d. Incorrect programming	d. Check for programming error
	e. Meter wire not installed securely into three pin connector	e. Verify meter cable wires are installed securely into three pin connector labeled METER
	f. Defective meter	f. Replace meter
	g. Defective PC Board	g. Replace PC Board

Problem	Possible Cause	Solution
8. Hard or untreated water is being delivered	a. Bypass valve is open or faulty	a. Fully close bypass valve or replace
	b. Media is exhausted due to high water usage	b. Check program settings or diagnostics for abnormal water usage
	c. Meter not registering	c. Remove meter and check for rotation or foreign material
	d. Water quality fluctuation	d. Test water and adjust program values accordingly
	e. No regenerant or low level of regenerant in regenerant tank	e. Add proper regenerant to tank
	f. Control fails to draw in regenerant	f. Refer to Trouble Shooting Guide number 12
	g. Insufficient regenerant level in regenerant tank	g. Check refill setting in programming. Check refill flow control for restrictions or debris and clean or replace
	h. Damaged seal/stack assembly	h. Replace seal/stack assembly
	i. Control valve body type and piston type mix matched	i. Verify proper control valve body type and piston type match
	j. Fouled media bed	j. Replace media bed
9. Control valve uses too much regenerant	a. Improper refill setting	a. Check refill setting
	b. Improper program settings	b. Check program setting to make sure they are specific to the water quality and application needs
	c. Control valve regenerates frequently	c. Check for leaking fixtures that may be exhausting capacity or system is undersized
10. Residual regenerant being delivered to service	a. Low water pressure	a. Check incoming water pressure – water pressure must remain at minimum of 25 psi
	b. Incorrect injector size	b. Replace injector with correct size for the application
	c. Restricted drain line	c. Check drain line for restrictions or debris and clean
11. Excessive water in regenerant tank	a. Improper program settings	a. Check refill setting
	b. Plugged injector	b. Remove injector and clean or replace
	c. Drive cap assembly not tightened in properly	c. Re-tighten the drive cap assembly
	d. Damaged seal/ stack assembly	d. Replace seal/ stack
	e. Restricted or kinked drain line	e. Check drain line for restrictions or debris and or un-kink drain line
	f. Plugged backwash flow controller	f. Remove backwash flow controller and clean or replace
	g. Missing refill flow controller	g. Replace refill flow controller
12. Control valve fails to draw in regenerant	a. Injector is plugged	a. Remove injector and clean or replace
	b. Faulty regenerant piston	b. Replace regenerant piston
	c. Regenerant line connection leak	c. Inspect regenerant line for air leak
	d. Drain line restriction or debris cause excess back pressure	d. Inspect drain line and clean to correct restriction
	e. Drain line too long or too high	e. Shorten length and or height
	f. Low water pressure	f. Check incoming water pressure – water pressure must remain at minimum of 25 psi

Problem	Possible Cause	Solution
13. Water running to drain	a. Power outage during regeneration	a. Upon power being restored control will finish the remaining regeneration time. Reset time of day.
	b. Damaged seal/ stack assembly	b. Replace seal/ stack assembly
	c. Piston assembly failure	c. Replace piston assembly
	d. Drive cap assembly not tightened in properly	d. Re-tighten the drive cap assembly
14. Err – 101 = Control unable to sense motor movement	a. Motor not inserted full to engage pinion, motor wires broken or disconnected	a. Disconnect power, make sure motor is fully engaged, check for broken wires, make sure two pin connector on motor is connected to the two pin connection on the PC Board labeled MOTOR. Press NEXT and REGEN buttons for 3 seconds to resynchronize software with piston position or disconnect power supply from PC Board for 5 seconds and then reconnect.
	b. PC Board not properly snapped into drive bracket	b. Properly snap PC Board into drive bracket and then Press NEXT and REGEN buttons for 3 seconds to resynchronize software with piston position or disconnect power supply from PC Board for 5 seconds and then reconnect.
	c. Missing reduction gears	c. Replace missing gears
15. Err – 102 = Control valve motor ran too short and was unable to find the next cycle position and stalled	a. Foreign material is lodged in control valve	a. Open up control valve and pull out piston assembly and seal/ stack assembly for inspection. Press NEXT and REGEN buttons for 3 seconds to resynchronize software with piston position or disconnect power supply from PC Board for 5 seconds and then reconnect.
	b. Mechanical binding	b. Check piston and seal/ stack assembly, check reduction gears, check drive bracket and main drive gear interface. Press NEXT and REGEN buttons for 3 seconds to resynchronize software with piston position or disconnect power supply from PC Board for 5 seconds and then reconnect.
	c. Main drive gear too tight	c. Loosen main drive gear. Press NEXT and REGEN buttons for 3 seconds to resynchronize software with piston position or disconnect power supply from PC Board for 5 seconds and then reconnect.
	d. Improper voltage being delivered to PC Board	d. Verify that proper voltage is being supplied. Press NEXT and REGEN buttons for 3 seconds to resynchronize software with piston position or disconnect power supply from PC Board for 5 seconds and then reconnect.

Problem	Possible Cause	Solution
16. Err – 103 = Control valve motor ran too long and was unable to find the next cycle position	a. Motor failure during a regeneration	a. Check motor connections then Press NEXT and REGEN buttons for 3 seconds to resynchronize software with piston position or disconnect power supply from PC Board for 5 seconds and then reconnect.
	b. Foreign matter built up on piston and stack assemblies creating friction and drag enough to time out motor	b. Replace piston and stack assemblies. Press NEXT and REGEN buttons for 3 seconds to resynchronize software with piston position or disconnect power supply from PC Board for 5 seconds and then reconnect.
	c. Drive bracket not snapped in properly and out enough that reduction gears and drive gear do not interface	c. Snap drive bracket in properly then Press NEXT and REGEN buttons for 3 seconds to resynchronize software with piston position or disconnect power supply from PC Board for 5 seconds and then reconnect.
17. Err – 104 = Control valve motor ran too long and timed out trying to reach home position	a. Drive bracket not snapped in properly and out enough that reduction gears and drive gear do not interface	a. Snap drive bracket in properly then Press NEXT and REGEN buttons for 3 seconds to resynchronize software with piston position or disconnect power supply from PC Board for 5 seconds and then reconnect.
18. Err – 106, Err - 116 = MAV/ SEPS/ NHBP/ AUX MAV valve motor ran too long and unable to find the proper park position Motorized Alternating Valve = MAV Separate Source = SEPS No Hard Water Bypass = NHBP Auxiliary MAV = AUX MAV	a. Control valve programmed for ALT A or b, nHbP, SEPS, or AUX MAV with out having a MAV or NHBP valve attached to operate that function	a. Press NEXT and REGEN buttons for 3 seconds to resynchronize software with piston position or disconnect power supply from PC Board for 5 seconds and then reconnect. Then re-program valve to proper setting
	b. MAV/ NHBP motor wire not connected to PC Board	b. Connect MAV/ NHBP motor to PC Board two pin connection labeled DRIVE. Press NEXT and REGEN buttons for 3 seconds to resynchronize software with piston position or disconnect power supply from PC Board for 5 seconds and then reconnect.
	c. MAV/ NHBP motor not fully engaged with reduction gears	c. Properly insert motor into casing, do not force into casing Press NEXT and REGEN buttons for 3 seconds to resynchronize software with piston position or disconnect power supply from PC Board for 5 seconds and then reconnect.
	d. Foreign matter built up on piston and stack assemblies creating friction and drag enough to time out motor	d. Replace piston and stack assemblies. Press NEXT and REGEN buttons for 3 seconds to resynchronize software with piston position or disconnect power supply from PC Board for 5 seconds and then reconnect.
19. Err – 107, Err - 117 = MAV/ SEPS/ NHBP/ AUX MAV valve motor ran too short (stalled) while looking for proper park position Motorized Alternating Valve = MAV Separate Source = SEPS No Hard Water Bypass = NHBP Auxiliary MAV = AUX MAV	a. Foreign material is lodged in MAV/ NHBP valve	a. Open up MAV/ NHBP valve and check piston and seal/ stack assembly for foreign material. Press NEXT and REGEN buttons for 3 seconds to resynchronize software with piston position or disconnect power supply from PC Board for 5 seconds and then reconnect.
	b. Mechanical binding	b. Check piston and seal/ stack assembly, check reduction gears, drive gear interface, and check MAV/ NHBP black drive pinion on motor for being jammed into motor body. Press NEXT and REGEN buttons for 3 seconds to resynchronize software with piston position or disconnect power supply from PC Board for 5 seconds and then reconnect.



A DIVISION OF C-B TOOL CO.