

CLICK ANYWHERE on THIS PAGE to return to Lancaster WATER SOFTENERS at [InspectApeia.com](http://InspectApeia.com)

**LANCASTER**  
WATER TREATMENT



## INSTALLATION, OPERATING AND SERVICE MANUAL

---

### **GOLD LINE LER ELECTRONIC WATER SOFTENER WITH THE LERCV1 VALVE**

- 7-LECR-50B
- 7-LECR-75B
- 7-LECR-100B
- 7-LER-75B
- 7-LER-100B
- 7-LER-150B
- 7-LER-200B



---

Congratulations on purchasing your new **Lancaster Water Softener**. This unit is designed to give you many years of trouble free service. When installed in accordance with the following instructions and if given reasonable care, clear-soft water will be the result. For servicing and future inspection purposes, please file this booklet with your important documents.

## OPERATING PARAMETERS

Minimum / Maximum Operating Pressures	20 psi (138 kPa) - 125 psi (862 kPa)
Minimum / Maximum Operating Temperatures	40°F (4°C) - 110°F (43°C)
Supply Voltage/ Frequency	120V AC/ 60 Hz      Other Options Available
Power Consumption	9.5 W
Output Voltage	12V AC
Output Current	500 mA

## GENERAL WARNINGS

The control valve, fittings and/or bypass are designed to accommodate minor plumbing misalignments but are not designed to support the weight of a system or the plumbing.

**HYDROCARBONS SUCH AS KEROSENE, BENZENE, GASOLINE, ETC., MAY DAMAGE PRODUCTS THAT CONTAIN O-RINGS OR PLASTIC COMPONENTS. EXPOSURE TO SUCH HYDROCARBONS MAY CAUSE THE PRODUCTS TO LEAK. DO NOT USE THE PRODUCT(S) CONTAINED IN THIS DOCUMENT ON WATER SUPPLIES THAT CONTAIN HYDROCARBONS SUCH AS KEROSENE, BENZENE, GASOLINE, ETC.**

**THIS WATER METER SHOULD NOT BE USED AS THE PRIMARY MONITORING DEVICE FOR CRITICAL OR HEALTH EFFECT APPLICATIONS**

Do not use Vaseline, oils, other hydrocarbon lubricants or spray silicone anywhere. A silicone lubricant may be used on black o-rings but is not necessary.

The nuts and caps are designed to be unscrewed or tightened by hand or with the special plastic wrench. If necessary a pliers can be used to unscrew the nut or cap. Do not use a pipe wrench to tighten or loosen nuts or caps. Do not place a screwdriver in the slots on caps and/or tap with a hammer.

Do not use pipe dope or other sealants on threads. Use Teflon tape on the threaded inlet, outlet and drain fittings. Teflon tape is not necessary on the nut connection or caps because of o-ring seals.

After completing any valve maintenance involving the drive assembly or the drive cap assembly and pistons unplug power source jack from the printed circuit board (black wire) and plug back in or press and hold NEXT and REGEN buttons for 3 seconds.

This resets the electronics and establishes the service piston position. The display should flash all wording, then flash the software version and then reset the valve to the service position.

All plumbing should be done in accordance with local plumbing codes. The pipe size for the drain line should be a minimum of ½". Backwash flow rates in excess of 7 gpm or length in excess of 20' require ¾" drain line.

Solder joints near the drain must be done prior to connecting the drain line flow control fitting. Leave at least 6" between the drain line control fitting and solder joints when soldering pipes that are connected on the drain line control fitting. Failure to do this could cause interior damage to the drain line flow control fitting.

When assembling the installation fitting package (inlet and outlet), connect the fitting to the plumbing system first and then attach the nut, split ring and o-ring. Heat from soldering or solvent cements may damage the nut, split ring or o-ring. Solder joints should be cool and solvent cements should be set before installing the nut, split ring and o-ring. Avoid getting primer and solvent cement on any part of the o-rings, split rings, bypass valve or control valve.

Plug into an electrical outlet. Note: All electrical connections must be connected according to local codes. (Be certain the outlet is uninterrupted.)

Install grounding strap on metal pipes.

This glass filled Noryl<sup>1</sup> (or equivalent) fully automatic control valve is designed as the primary control center to direct and regulate all cycles of a water softener or filter. When the LERCV1 control valve is manufactured as a softener, the control valve can be ordered to perform downflow or upflow regeneration. When the LERCV1 control valve is set up as a filter, the control valve can be set to perform downflow regeneration or simply backwash. The control valve can be set to regenerate on demand (consumption of a predetermined amount of water) and/or as a time clock (passage of a particular number of days). The control valve can be set so that a softener can meet the Water Quality Association (WQA) Standard S100 or NSF/ANSI Standard 44 efficiency rating.

**It is not recommended to change control valves from downflow to upflow brining or vice versa in the field. The valve bodies for downflow and upflow are unique to the regeneration type and should not be interchanged. A mismatch of valve body and regeneration piston will result in hard water bypass during service.**

The control valve is compatible with a variety of regenerants and resin cleaners. The control valve is capable of routing the flow of water in the necessary paths to regenerate or backwash water treatment systems. The injector regulates the flow of brine or other regenerants. The control valve regulates the flow rates for backwashing, rinsing, and the replenishing of treated water into a regenerant tank, when applicable.

The control valve uses no traditional fasteners (e.g. screws); instead clips, threaded caps and nuts and snap type latches are used. Caps and nuts only need to be firmly hand tightened because radial seals are used. Tools required to service the valve include one small blade screw driver, one large blade screw driver, pliers and a pair of hands. A plastic wrench is available which eliminates the need for screwdrivers and pliers. Disassembly for servicing takes much less time than comparable products currently on the market. Control valve installation is made easy because the distributor tube can be cut 1/2" above to 1/2" below the top of tank thread. The distributor tube is held in place by an o-ring seal and the control valve also has a bayonet lock feature for upper distributor baskets.

The AC adapter comes with a 15 foot power cord and is designed for use with the control valve. The AC adapter is for dry location use only. The control valve remembers all settings until the battery power is depleted if the power goes out. After the battery power is depleted, the only item that needs to be reset is the time of day; other values are permanently stored in the nonvolatile memory. The control valve battery is not rechargeable but is replaceable.

## INSTALLATION

Allow one foot of clearance to service the valve.

The valve will withstand transportation and storage temperatures of -13 °F (-25 °C) to 131 °F (55 °C) and for short periods up to 158 °F (70 °C). If valve has been exposed to freezing conditions let valve warm up to room temperature before running water through it. The valve has been packaged to prevent damage from the effects of normal humidity, vibration and shock.

Place softener in desired location close to water supply inlet, after pressure tank, and near a source for waste water, (utility sink, floor drain or sewer line). A 115/120V, 60 Hz uninterrupted outlet is required. Keep softener far enough away from walls and other obstructions to allow enough room for servicing the unit. All sillcocks and similar fixtures that will use untreated water must have their pipes connected to the hard water side of the softener. The bypass valve should be installed so that water will be available if it should be necessary to shut off the pressure in order to service the softener.

The cabinet tank or mineral tank must be reasonably level and solidly in place. Prior to beginning work to the system, make sure that water pressure is shut off at the incoming water supply and that several water spigots are open to provide sufficient venting for drainage of that system.

Arrows are molded into the control valve to show the direction of the flow.

**BYPASS VALVE:** The bypass valve easily connects to the control valve body using nuts that only require hand tightening. Install with red knobs in the upward position. Press end of bypass valve with o-rings into valve. Hand tighten nuts. Place into **BYPASS OPERATION** (figure 1 page 3).

Avoid getting primer and solvent cement on any part of the o-rings or split rings, bypass valve or control valve. **DO NOT** use pipe dope or any other sealant on threads. Teflon tape is not necessary on the caps because of o-ring seals. Do not use Vaseline or other unacceptable lubricants on o-rings. A silicone lubricant may be used on black o-rings.

**DRAIN LINE:** The 3/4" drain line elbow accommodates 5/8" poly tube or 3/4" NPT drain line connections. The nut and poly tube insert for the 3/4" drain line elbow is designed for use with flexible poly tube only. The drain line elbow can be rotated so the outlet can be oriented toward the nearest drain

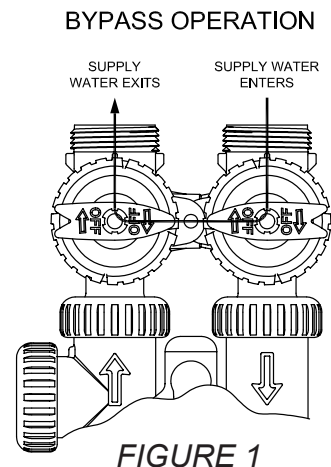
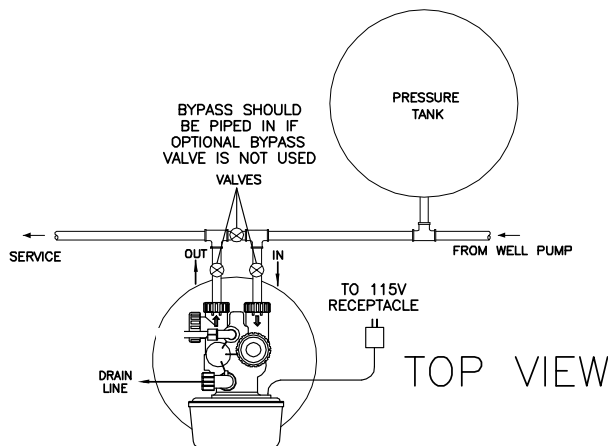
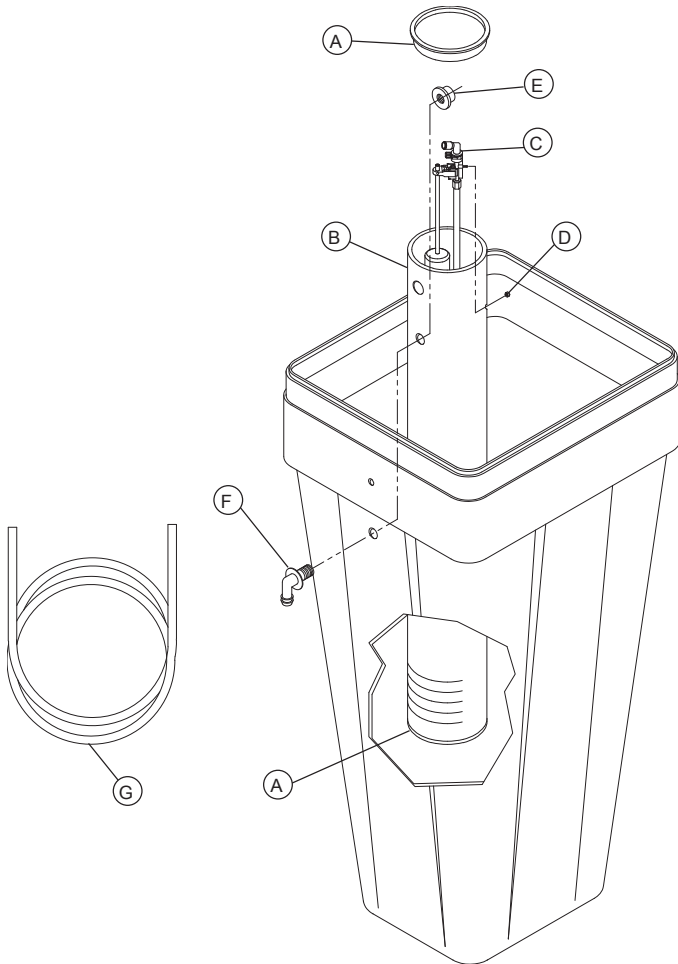

FIGURE 1

**TO INSTALL 5/8" POLY TUBE DRAIN LINE:** The poly tube insert is shipped attached to the drain line elbow's locking clip. Press the insert into the drain line (5/8" poly tube not included). Loosen nut of the drain line elbow. Press 5/8" poly tube with insert into the drain line elbow until it seats on the back of the fitting. Tighten nut.

It is simplest to run the drain line into a sump pump pit or washing machine drain if possible. If this is not practical, a fitting with a trap must be installed in a sewer line. Place the trap as close to the vent as possible to prevent siphoning of the trap when large amounts of waste water go through the sewer line. **DO NOT** pipe the drain line solidly into the waste line, as this is prohibited by most plumbing codes. The drain line should enter the trap from above so the water will not back up in the drain line if sewer should become plugged up and the trap overflow. The trap should have a short pipe extending from it to prevent splashing when water runs into the trap from drain line.



**ASSEMBLE THE BRINE TANK:** Install a brine well cap (Item A) on the bottom of the brine well (Item B). Remove the brine valve assembly (Item C) from the brine well by removing the nut (Item D). Attach the brine well to the brine tank with the two-piece overflow (Items E & F) using the lower holes in both pieces, as shown. Reinstall the brine valve assembly. Push brine line polytube (Item G) through the upper holes in the brine tank and brine well and press the polytube into the elbow fitting.

**BRINE LINE CONNECTIONS:** Connect the brine line polytubing found with the brine tank to the brine connection on the control valve. The control valve has a standard refill elbow to which a 3/8" flexible tube can be connected, see below. Press the polytube into the brine elbow fitting. Make sure the floor is clean beneath the brine tank and that it is level and smooth.

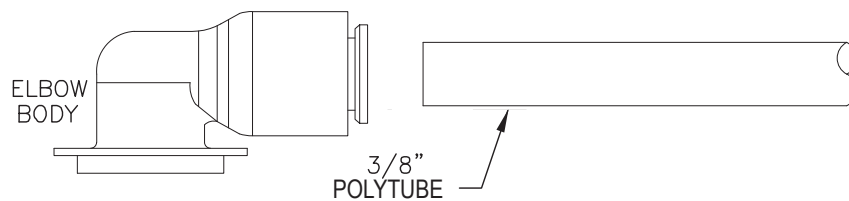

### BRINE LINE FITTING CONNECTIONS

**BRINE TANK OVERFLOW PRECAUTION:** A 1/2" (inside diameter, not provided) gravity drain line should be connected to the overflow fitting on the side of the brine tank. This overflow is in case of a malfunction in the brine shut off. If the unit is installed where water may flow in the event of an overflow and cause water damage, connect a length of flexible tubing and run to a drain below the level of the overflow. **(Do not connect the tubing to the drain line on the control valve. Do not run tubing above overflow height at any point.)**

**PROGRAMMING THE CONTROL VALVE:** Note: A quick-reference card is stored inside the front cover of the control valve. To access this card, slightly pull tabs on side of cover outward and pull cover forward. Plug the electrical cord into a 115 Volt receptacle. **DO NOT** plug into an outlet controlled by a wall switch or pull chain that could inadvertently be turned off. Wait a couple of seconds for control valve to "home" itself. Panel should display "TIME" and the time of day will be flashing.

## SET TIME OF DAY

Current time of day needs to be entered during initial installation, and adjusted when daylight saving time begins or ends. If an extended power outage occurs and depletes the on-board non-rechargeable coin cell battery, when power resumes the time of day should be reset and battery replaced.

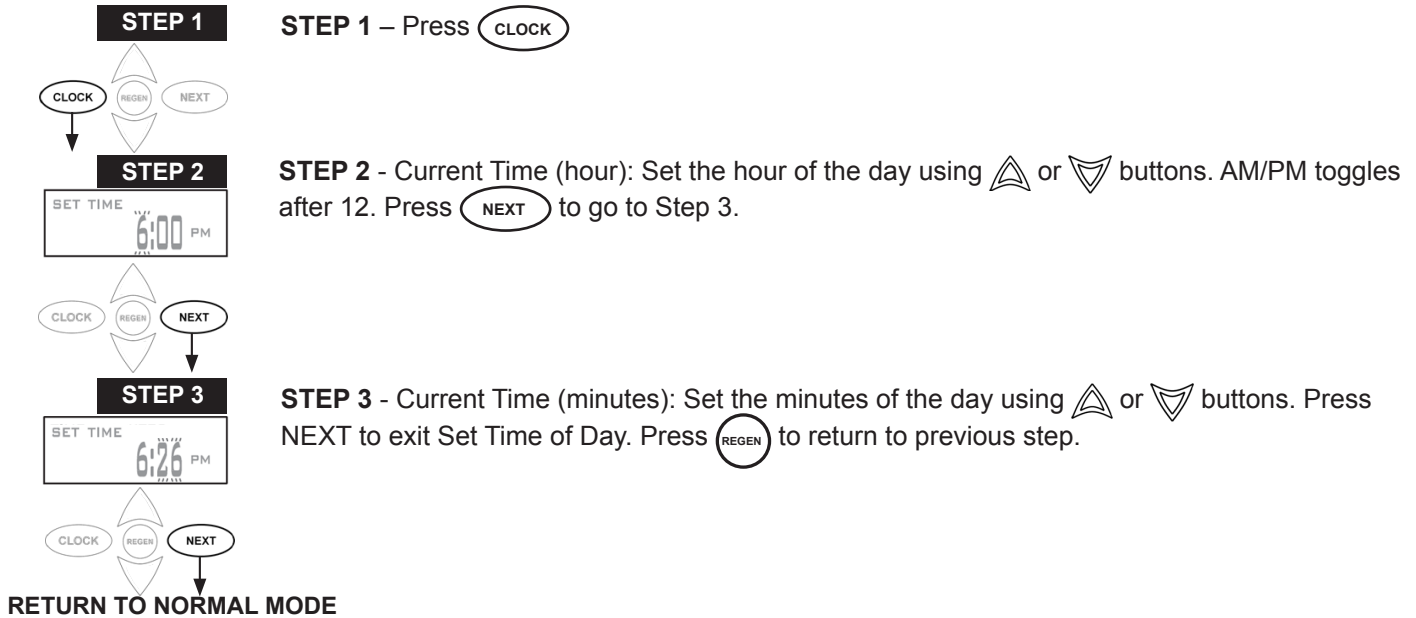

## ADJUST HARDNESS, DAYS BETWEEN REGENERATIONS, OR TIME OF REGENERATION

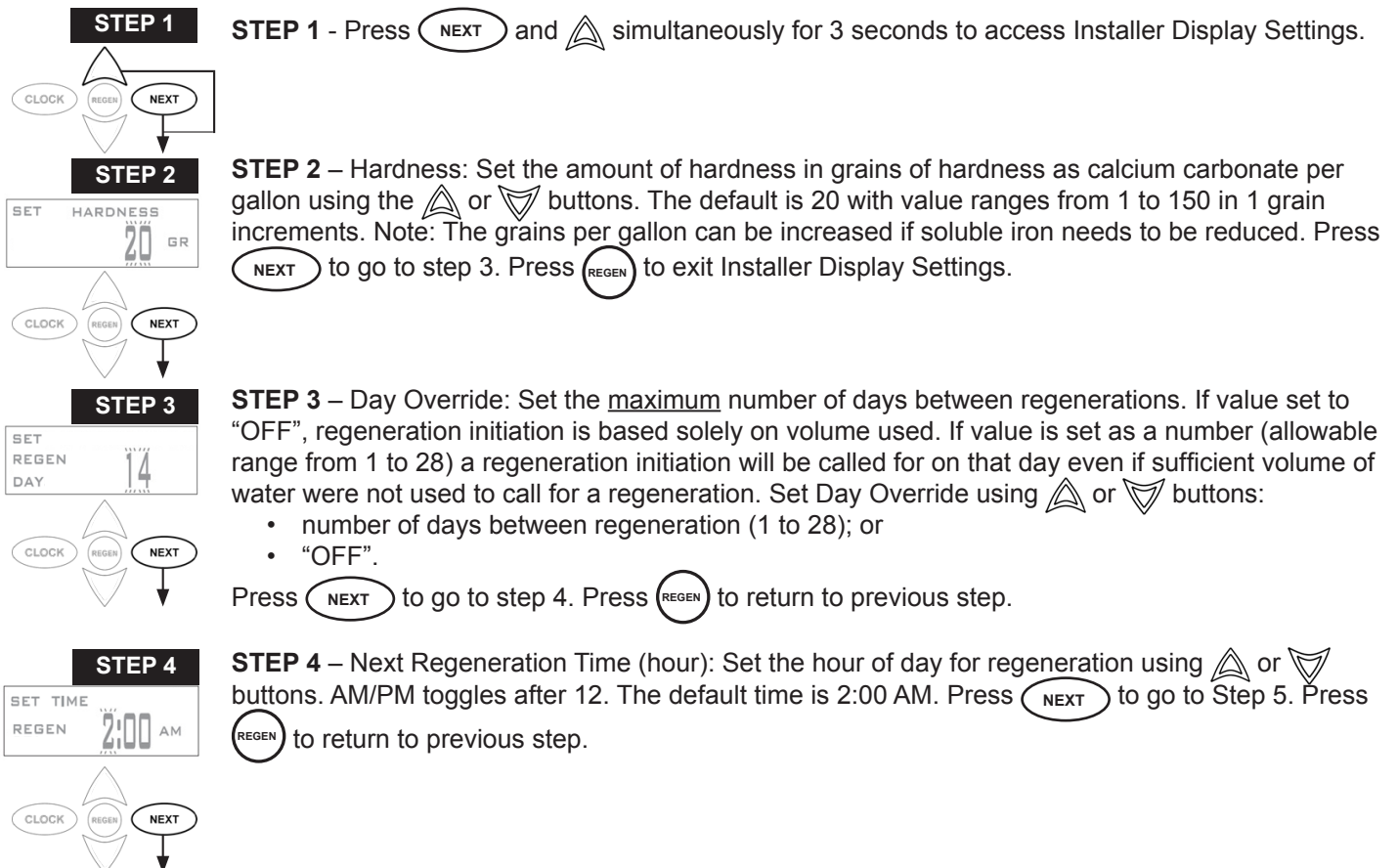

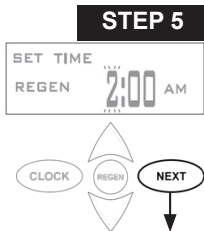

**STEP 5** – Next Regeneration Time (minutes): Set the minutes of day for regeneration using or buttons. Press to return to normal operation. Press to return to previous step.

**RETURN TO NORMAL MODE**

**PLACING UNIT INTO SERVICE:** Make sure inlet and outlet valves are to their closed positions. If using optional bypass, place in bypass position. Turn on main water supply. Open a cold water faucet. This will clear the lines of any debris (solder, pipe dope, etc.) that may be in the line. Let water run at tap for a couple of minutes, or until clear. Turn off faucet. Manually add 1½ gallons of water to the brine tank.

- Press and hold the **REGEN** button for approximately 5 seconds until the motor starts.
- Wait until display reads **BACKWASH** and numbers start counting down.
- Momentarily press **REGEN** again. Wait until display reads **BRINE** and numbers start counting down.
- Momentarily press **REGEN** again. Valve is now in the second **BACKWASH** position.

If using optional bypass **SLOWLY** turn bypass valve to **DIAGNOSTIC** position (**figure 2**) or slowly open inlet valve to allow water to slowly enter the softener.

When water is flowing steadily to drain without the presence of air, momentarily press **REGEN** again. Display will read **RINSE**.

Open the outlet valve of the softener, or if using optional bypass place to **NORMAL OPERATION MODE** (**figure 3**).

Allow control to finish the **RINSE** cycle. It will then advance to the **FILL** position. The brine tank will now automatically fill with the proper volume of water for the first regeneration.

Allow the control to automatically advance to the **SOFTENING** position.

Load the brine tank with salt. Solar Salt is recommended.

**SANITIZING:** Use 2 oz. of 5¼% household chlorine bleach for each cubic foot of resin. Pour bleach directly into the brine well of the softener. Press and hold the REGEN button for 5 – 6 seconds until the motor starts running. Allow system to complete the regeneration automatically. Check for other local and state codes which may also specify sanitation methods.

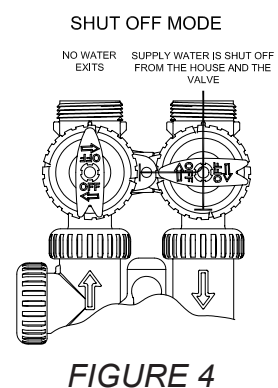
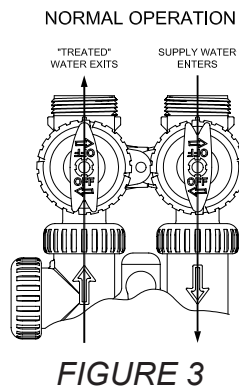
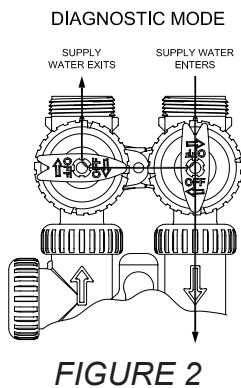

## OPTIONAL MAINTENANCE WRENCH

Part Number V3193

Although no tools are necessary to assemble the valve, the optional maintenance wrench (shown in various positions on the valve) may be purchased to aid in assembly or disassembly.

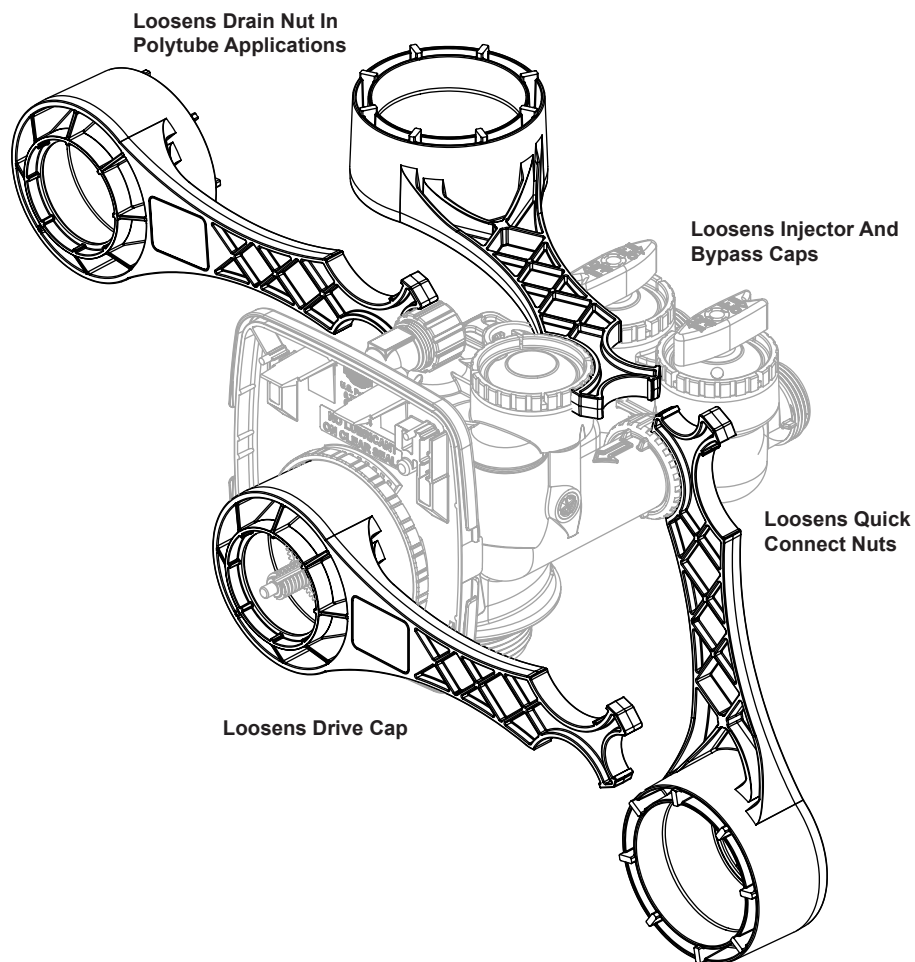

**BYPASS VALVE:** The bypass valve is typically used to isolate the control valve from the plumbing system's water pressure in order to perform control valve repairs or maintenance. The WS1 bypass valve is particularly unique in the water treatment industry due to its versatility and state of the art design features. The 1" full flow bypass valve incorporates four positions, including a diagnostic position that allows service personal to work on a pressurized system while still providing untreated bypass water to the facility or residence. Its completely non-metallic, all-plastic design allows for easy access and serviceability without the need for tools.

The bypass body and rotors are glass filled Noryl<sup>3</sup> (or equivalent) and the nuts and caps are glass filled polypropylene. All seals are self-lubricating EPDM to help prevent valve seizing after long periods of non-use. Internal o-rings can easily be replaced if service is required.

The bypass consists of two interchangeable plug valves that are operated independently by red arrow-shaped handles. The handles identify the flow direction of the water. The plug valves enable the bypass valve to operate in four positions.

- 1. Normal Operation Position:** The inlet and outlet handles point in the direction of flow indicated by the engraved arrows on the control valve. Water flows through the control valve during normal operation and this position also allows the control valve to isolate the media bed during the regeneration cycle. (See Figure 3)
- 2. Bypass Position:** The inlet and outlet handles point to the center of the bypass, the control valve is isolated from the water pressure contained in the plumbing system. Untreated water is supplied to the plumbing system. (See Figure 1)
- 3. Diagnostic Position:** The inlet handle points in the direction of flow and the outlet handle points to the center of bypass valve, system water pressure is allowed to the control valve and the plumbing system while not allowing water to exit from the control valve to the plumbing. (See Figure 2)
- 4. Shut Off Position:** The inlet handle points to the center of the bypass valve and the outlet handle points in the direction of flow, the water is shut off to the plumbing system. If water is available on the outlet side of the softener it is an indication of water bypass around the system (i.e. a plumbing connection somewhere in the building bypasses the system). (See Figure 4)

## SERVICE INSTRUCTIONS

### DRIVE ASSEMBLY:

The drive assembly consists of the following parts:

- Drive Bracket
- Printed Circuit (PC) Board
- Motor
- Drive Gears
- Drive Gear Cover

The drive bracket holds the PC board, the motor, the drive gears and the drive gear cover in place.

The PC board receives and retains information, displays the information, determines when to regenerate and initiates regeneration. The display shows different types of information in the initial system set up (for softeners or filters), installer display settings, diagnostics, valve history or user display settings.

The PC board powers the motor. The PC board's two-prong jack connects wires to the direct current (DC) motor. The motor is held in place on the drive bracket by a spring-loaded clip and a small bulge in the plastic, which fits in one of the slots on the motor housing. The motor turns drive gears that drive the piston to cycle positions for backwashing, regeneration, rinsing, refill or service. The motor is fully reversible (turns both ways) and changes direction of rotation to change the direction of piston motion. The motor is easily replaced if necessary.

There are three drive gears held in place by the drive gear cover. All three drive gears are the same size. A reflective coating is applied to the gears. As the center drive gear turns a light shines on the coating and a light sensing diode determines if a light pulse was returned. The PC board counts the pulses and determines when to stop driving the motor.



When servicing the valve, water may leak from the valve. Water from the valve may create a slip hazard. Clean up water spills.



Disconnect from electrical power prior to servicing the valve.

Remove the valve cover to access the drive assembly.

Disconnect the power source plug (black wire) from the PC board prior to disconnecting the motor or water meter plugs from the PC board. The power source plug connects to the four-pin jack. The motor plug connects to the two-pin jack on the left-hand side of the PC board. The water meter plug (gray wire) connects to the three-pin jack on the far right-hand side of the PC board.

The PC board can be removed separately from the drive bracket but it is not recommended. Do not attempt to remove the display panel from the PC board. Handle the board by the edges. To remove the PC board from the drive bracket, unplug the power, water meter and motor plugs from the PC board. Lift the middle latch along the top of the drive bracket while pulling outward on the top of the PC board. The drive bracket has two plastic pins that fit into the holes on the lower edge of the PC board. Once the PC board is tilted about 45° from the drive bracket it can be lifted off of these pins. To reinstall the PC board, position the lower edge of the PC board so that the holes in the PC board line up with the plastic pins. Push the top of the PC board towards the valve until it snaps under the middle latch, weave the power and water meter wires into the holders and reconnect the motor, water meter and power plugs.

The drive bracket must be removed to access the drive cap assembly and pistons or the drive gear cover. It is not necessary to remove the PC board from the drive bracket to remove the drive bracket. To remove the drive bracket start by removing the plugs for the power source and the water meter. Unweave the wires from the side holders. Two tabs on the top of the drive back plate hold the drive bracket in place. Simultaneously lift the two tabs and gently ease the top of the drive bracket forward. The lower edge of the drive bracket has two notches that rest on the drive back plate. Lift up and outward on the drive bracket to disengage the notches.

To reassemble, seat the bottom of the drive bracket so the notches are engaged at the bottom of the drive back plate. Push the top of the drive bracket toward the two latches. The drive bracket may have to be lifted slightly to let the threaded piston rod pass through the hole in the drive bracket. Maintain a slight engaging force on top of the drive bracket while deflecting the bracket slightly to the left by pressing on the side of the upper right corner. This helps the drive gears mesh with the drive cap assembly. The drive bracket is properly seated when it snaps under the latches on the drive back plate. If resistance is felt before latching, then notches are not fully engaged, the piston rod is not in hole, the wires are jammed between the drive bracket and drive back plate, or the gear is not engaging the drive cap assembly.

To inspect the drive gears, the drive gear cover needs to be removed. Before trying to remove the gear cover, the drive bracket must be removed from the drive back plate. (Refer to the instructions above regarding removing the drive bracket from the drive back plate. The drive gear cover can be removed from the drive bracket without removing the motor or the PC board.) The drive gear cover is held in place on the drive bracket by three clips. The largest of the three clips is always orientated to the bottom of the drive bracket. With the PC board facing up, push in and down on the large clip on the drive gear cover. Handle the cover and the gears carefully so that the gears do not fall off the pegs in the cover.



Replace broken or damaged drive gears. Do not lubricate any of the gears. Avoid getting any foreign matter on the reflective coating because dirt or oils may interfere with pulse counting.

The drive gear cover only fits on one way, with the large clip orientated towards the bottom. If all three clips are outside of the gear shroud on the drive bracket the drive gear cover slips easily into place.

The drive bracket does not need to be removed from the drive plate if the motor needs to be removed. To remove the motor, disconnect the power and motor plugs from the jacks on the PC board. Move the spring clip loop to the right and hold. Rotate the motor at least a ¼ turn in either direction so the wires are vertical (up & down) before gently pulling on the wire connectors to remove the motor. Pulling directly on the wires without rotating the motor may break the wires off the motor.

#### **DRIVE CAP ASSEMBLY, MAIN PISTON AND REGENERANT PISTON:**

The drive gears turn the main gear of the drive cap assembly, which moves the piston. The screw-driven, horizontally moving piston stops at specific positions to direct the flow of water to backwash, regenerate, rinse or refill. The PC board determines the position of the piston by counting pulses produced when the piston is moved. An optical sensor looking at one of the reduction drive gears generates these pulses. Each cycle position is defined by a number of pulses. The counter is zeroed each time the valve goes to the service position. The PC board finds the service position by noting the increase in current delivered to the motor when the mechanical stop at the service position is reached. This method of controlling piston position allows for greater flexibility and requires no switches or cams (U.S. Patent 6444127).

A regenerant piston must be attached to the main piston.

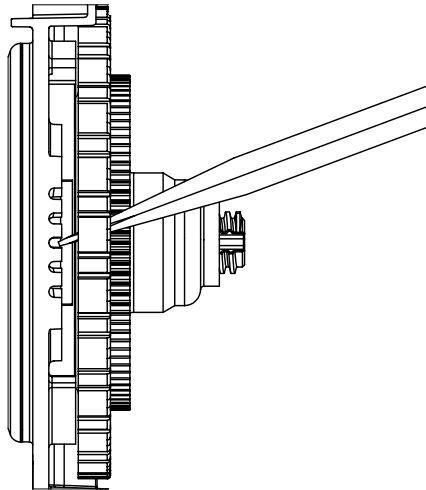

#### **SPACER STACK ASSEMBLY:**

The spacer stack assembly provides the necessary flow passage for water during the different cycles. The all-plastic spacer stack assembly (U.S. Patent 6402944) is a one-piece design which allows the stack to be removed using your fingers.

The exterior of the stack is sealed against the body bore with self lubricating EPDM o-rings, while the interior surface is sealed against the piston using slippery self cleaning directional (one-way) silicone lip seals. The lip seals are clear in color and have a special slippery coating so that the piston does not need to be lubricated.

### **INJECTOR CAP, SCREEN, INJECTOR PLUG AND INJECTOR:**

The screen, injector and/or injector plug(s) are installed under the injector cap in an easy to access location on top of the valve. The injector cap contains four slots so no water accumulates in the cap. The injector cap is designed to be hand tightened.

Under the injector cap there is an easy to clean removable screen to prevent fouling of the injector. There are two holes under the injector cap labeled "DN" and "UP". The holes will be filled with a plug or an injector.

The plug (Order # V3010-1Z) prevents water from traveling a certain pathway. The injector lets water pass through the pathway. The self-priming injector increases the velocity of the water, creating a zone of negative pressure that draws in the concentrated liquid regenerant, such as sodium chloride (brine), potassium permanganate, etc. The regenerant blends with the stream of water, which passes through the media to regenerate the bed.

The injector provides a consistent regenerant/water mixture ratio over the entire operating pressure range of the control valve. The injector provides good performance in a variety of applications, which may involve elevated drain lines and long regenerant draw lengths. Injectors are chosen by knowing the type, amount, and regenerant flow rate for a particular type of media. Guidelines can be found in the media manufacturer's literature. The color coded injectors give different regenerant draw, slow rinse and total flow rates over the pressure range.

NOTE: It is not recommended to field convert valves from upflow to downflow and vice versa. Separate areas in the valve supply water to the injector for upflow and downflow valves.

### **REFILL FLOW CONTROL ASSEMBLY OR REFILL PORT PLUG:**

The refill flow control assembly consists of a refill flow elbow, refill flow control retainer assembly, refill flow control, polytube insert and nut assembly. The refill flow control retainer fits in the refill elbow. The refill flow control retainer houses the refill flow control which controls the flow rate when the regenerant tank is being refilled. The refill flow control is a flexible washer-like part with a small orifice and a precision molded contour that delivers a steady 0.5 gpm regenerant tank refill rate at varying inlet pressures. Refill is accomplished with treated water.

The refill flow control assembly is installed in an easy to access refill elbow located on top of the control valve. The refill flow control assembly is attached to the control valve with a locking clip. The locking clip allows the elbow to rotate 270 degrees so the outlet can be orientated towards the regenerant tank.

The control valve has a standard refill elbow to which a 3/8" flexible tube can be connected.

### **WATER METER:**

The water meter is installed on the outlet side of the control valve. The water meter uses a turbine to measure gallons of treated water. The turbine rotates with the flow of water and reports its rate of rotation through Hall effect<sup>2</sup> circuitry to the printed circuit (PC) board. This rotation permits the PC board to record the total volume of treated water and the flow rate. The small centrally located magnet is shielded from water, which substantially reduces iron-fouling problems with the turbine.

**THIS WATER METER SHOULD NOT BE USED AS THE PRIMARY MONITORING DEVICE FOR CRITICAL OR HEALTH EFFECT APPLICATIONS.**

**OPERATING PRESSURES: 20 PSI MINIMUM / 125 PSI MAXIMUM • OPERATING TEMPERATURES: 40°F MINIMUM / 110°F MAXIMUM**

The turbine is accurate to within  $\pm 5\%$  over a wide operating flow rate range (0.25 gpm (0.95 lpm) up to control valve maximums) and has a very low pressure drop. Water used for regeneration is not metered. If the control valve is set to prefill the regenerant, water used between the prefill cycle up to the start of the regeneration cycle is metered. If the control valve is in regeneration mode (e.g. a backwash cycle) and there is a water demand, that water usage is not metered.

When facing the front of the control valve, the water meter is positioned on the left-hand side of the control valve. Allow sufficient clearance to clean and repair the water meter without disconnecting the plumbing or disassembling any other parts of the control valve.

Control valves can be ordered with a meter plug (i.e. no electronics or turbine) rather than a water meter if desired. Control valves without meters should only be set up for time clock operation (i.e. no water meter, no demand-initiated regeneration). Control valves with water meters provide a wider variety of useful information. Do not lubricate the turbine shaft. The turbine shaft bearings are pre-lubricated. Do not use Vaseline, oils or other unacceptable lubricants on the o-ring. A silicone may be used on the black o-ring. Snap the turbine on the shaft and reinsert the water meter into the side slot. Hand tighten the nut. Do not use a pipe wrench to tighten nut.

When replacing the battery, align positives and push down to fully seat.  
 Correct Battery Orientation  
 Battery replacement is 3 volt lithium coin cell type 2032.

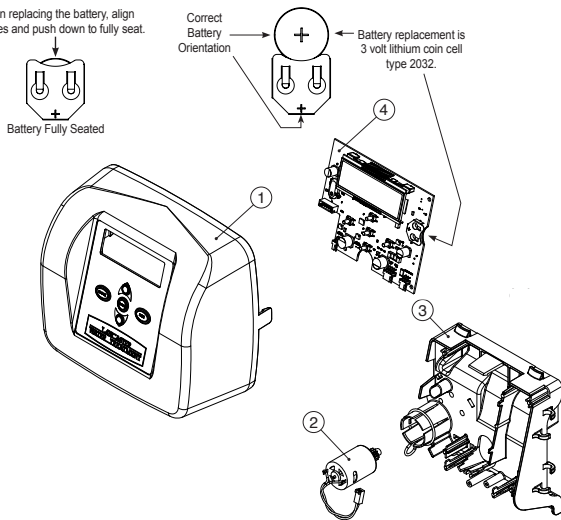

## FRONT COVER AND DRIVE ASSEMBLY

Item No.	Qty.	Part No.	Description
1	1	V4170	Front Cover Assembly
2	1	V3107	Motor
3	1	V3106	Drive Bracket, Spring Clip, Drive Gear 12 x 36 & Drive Gear Cover
4	1	V4179LC-BOARD	PC Board
Not Shown	1	V3186	Transformer 110V-12V

## DRIVE CAP ASSEMBLY, DOWNFLOW PISTON, REGENERANT PISTON AND SPACER STACK ASSEMBLY

Item No.	Quantity	Part No.	Description
1	1	V3005	Spacer Stack Assembly
2	1	V3004	Drive Cap Assembly
3	1	V3135	O-Ring 228
4	1	V3011	Piston Assembly
5	1	V3174	Regenerant Piston
6	1	V3105	O-Ring 215
7	1	V3180	O-Ring 337
8	1	V3946	Back Plate

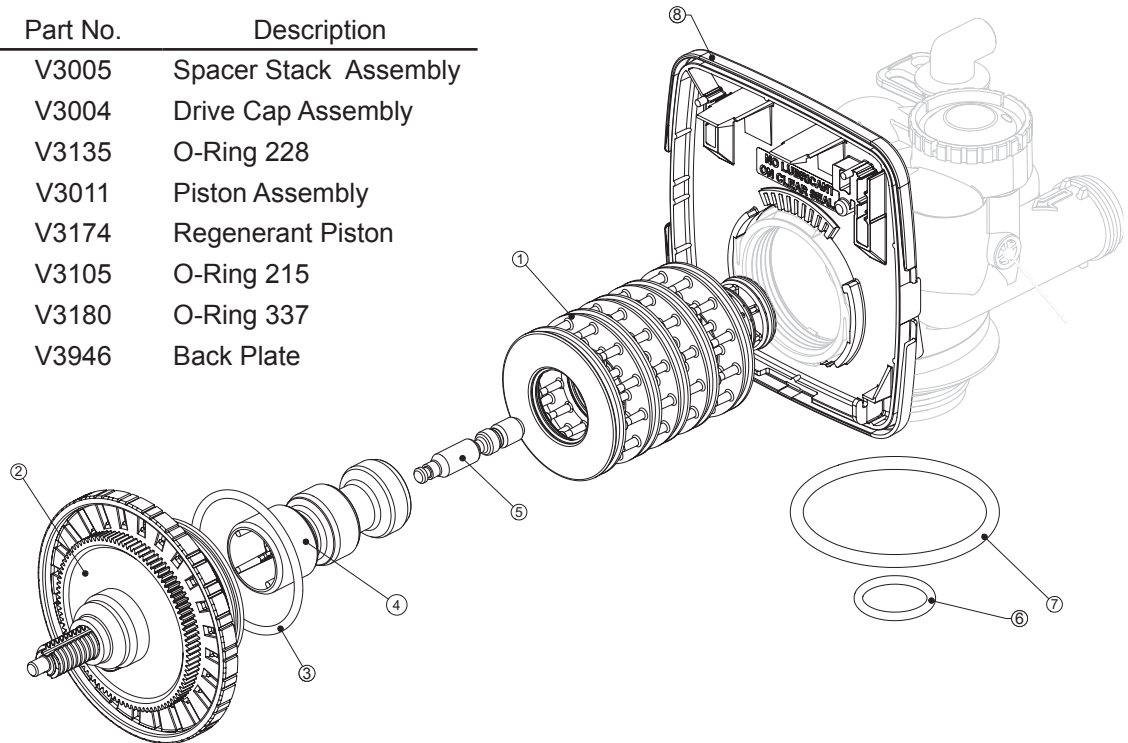

## INJECTOR, INJECTOR CAP, SCREEN AND O-RING

Item No.	Quantity	Part No.	Description
1	1	V3176	Injector Cap
2	1	V3152	O-Ring 135
3	1	V3177	Injector Screen
4	1	V3010-1Z	Injector Assy Z Plug
5	1	V3010-1C	Injector Assy C Violet
5	1	V3010-1E	Injector Assy E White
5	1	V3010-1F	Injector Assy F Blue
5	1	V3010-1G	Injector Assy G Yellow
Not Shown	*	V3170	O-Ring 011
Not Shown	*	V3171	O-Ring 013

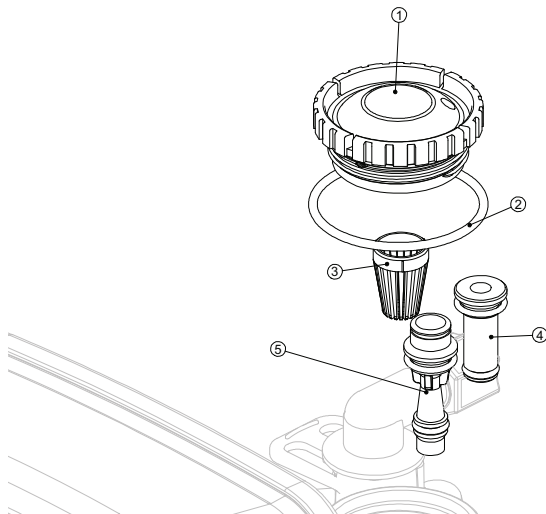

\* Injector plug and injector each contain one 011 and one 013 O-Ring

## WATER METER AND METER PLUG

Item No.	Quantity	Part No.	Description
1	1	V3151	Nut 1" QC
2	1	V3003*	Meter Assy
3	1	V3118-01	Turbine Assy
4	1	V3105	O-Ring 215
5	1	V3003-01	Meter Plug Assy

\*Part No. V3003 includes Items 2, 3 and 4

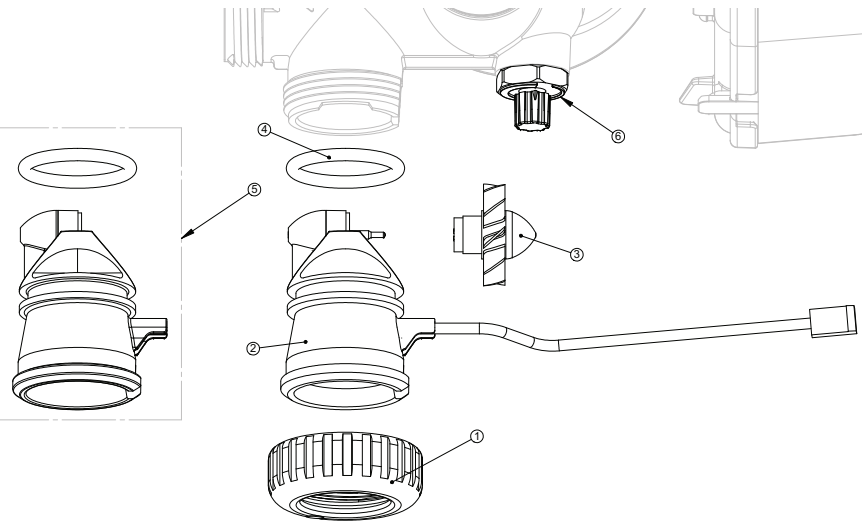

## DRAIN LINE - 3/4"

Item No.	Quantity	Part No.	Description
1	1	H4615	Elbow Locking Clip
2	1	V3194	Polytube Insert 5/8
3	1	V3192	Nut for 3/4 Drain Elbow
4	1	V3158	3/4 Drain Elbow
5	1	V3163	O-Ring 019
6	1	V3159	DLFC Retainer
7	1	V3162-010	DLFC 1.0
7	1	V3162-017	DLFC 1.7
7	1	V3162-027	DLFC 2.7
7	1	V3162-032	DLFC 3.2
7	1	V3162-042	DLFC 4.2

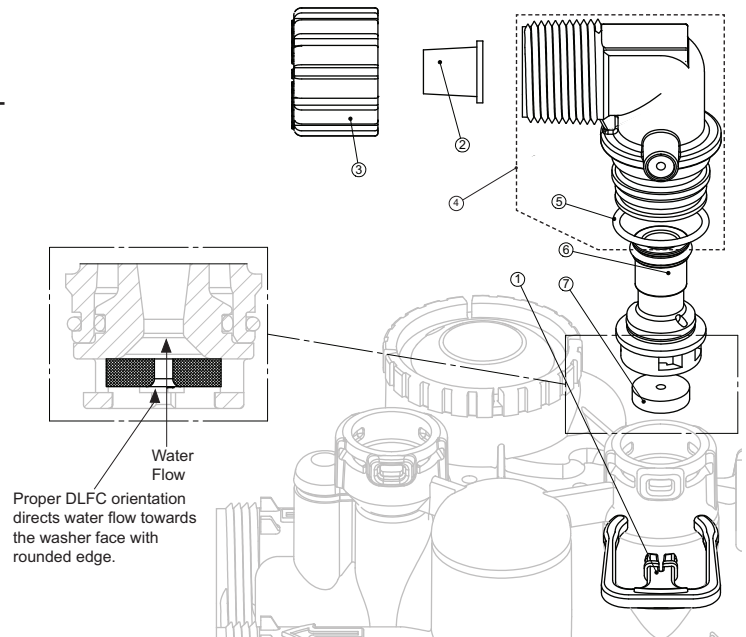

## BRINE REFILL

Item No.	Qty,	Part No.	Description
1	1	H4615	Elbow Locking Clip
2	1	H4628	Elbow 3/8" Liquifit
3	1	V3163	O-ring 019
4	1	V3165-01*	RFC Retainer Assy (0.5 gpm)
5	1	V3182	RFC
6	1	V4144-01	Elbow 3/8 Liquifit Assy w/RFC

\*Assembly includes V3182 RFC.

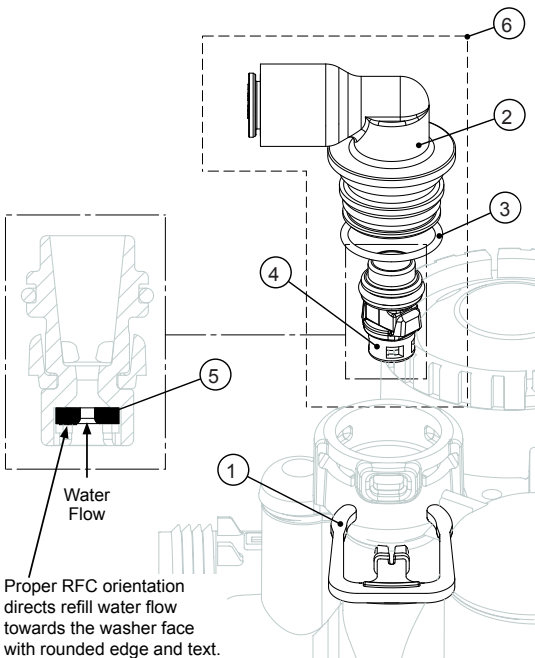

# PARTS

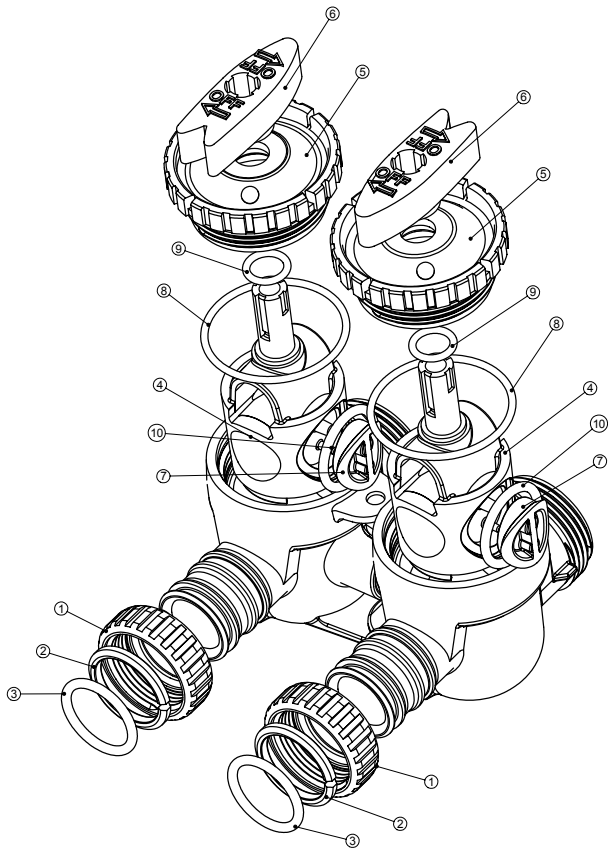

## BP2000 Bypass Valve

Item No.	Qty	Part No.	Description
1	2	V3151	Nut 1" Quick Connect
2	2	V3150	Split Ring
3	2	V3105	O-Ring 215
4	2	V3145	Bypass 1" Rotor
5	2	V3146	Bypass Cap
6	2	V3147	Bypass Handle
7	2	V3148	Bypass Rotor Seal Retainer
8	2	V3152	O-Ring 135
9	2	V3155	O-Ring 112
10	2	V3156	O-Ring 214

### ADDITIONAL OPTIONAL FITTINGS

Part Number	Description
V3007-01	3/4" X 1" PVC Solvent Elbow Assembly
V3007-02	1" Brass Sweat Assembly
V3007-03	3/4" Brass Sweat Assembly
V3007-04	1" Plastic Male NPT Assembly
V3007-05	1-1/4" Plastic Male NPT Assembly
V3007-07	1-1/4" & 1-1/2" PVC Solvent Elbow Assy
V3007-09	1-1/4" & 1-1/2" Brass Sweat Assembly
V3007-12	3/4" Shark Bite Assembly
V3007-13	1" Shark Bite Assembly
V3007-15	3/4" John Guest QC Elbow Assembly
V3007-17	1" John Guest Straight QC
V3007-18	3/4" Plastic Male NPT Straight Fitting Kit
V3007-19	3/4" John Guest® Straight Fitting Kit

## V3007 1" PVC Male NPT Elbow Assembly Standard

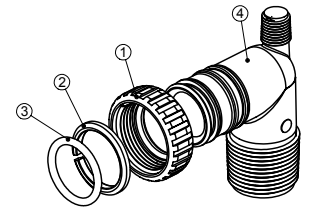

Item No.	Qty	Part No.	Description
1	2	V3151	Nut 1" Quick Connect
2	2	V3150	Split Ring
3	2	V3105	O-Ring 215
4	2	V3149	1" PVC Male NPT Elbow

## V3191-01 Vertical Adapter Assembly Optional

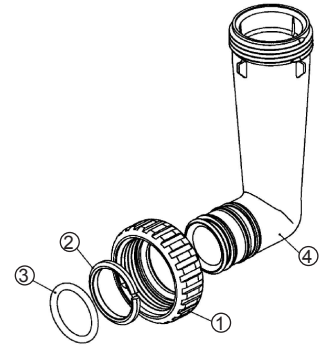

Item No.	Qty	Part No.	Description
1	2	V3151	Nut 1" Quick Connect
2	2	V3150	Split Ring
3	2	V3105	O-Ring 215
4	2	V3191	Vertical Adapter

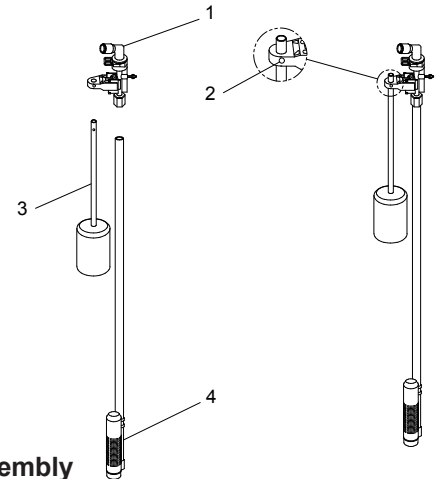

## 4740 Brine Valve Assembly

Item No.	Qty	Part No.	Description
1	1	H4600	3/8" Safety Brine Valve
2	2	10151	Pin
3	1	H4640-32	Float Assembly
4	1	H4500-30.50	Air Check Assembly

# TROUBLESHOOTING PROCEDURES

PROBLEM	POSSIBLE CAUSE	SOLUTION
1. Timer does not display time of day.	<ul style="list-style-type: none"> <li>a. Transformer unplugged</li> <li>b. No electric power at outlet</li> <li>c. Defective transformer</li> <li>d. Defective PC board</li> </ul>	<ul style="list-style-type: none"> <li>a. Connect power</li> <li>b. Repair outlet or use working outlet</li> <li>c. Replace transformer</li> <li>d. Replace PC board</li> </ul>
2. Timer does not display correct time of day.	<ul style="list-style-type: none"> <li>a. Switched outlet</li> <li>b. Power outage</li> <li>c. Defective PC board</li> </ul>	<ul style="list-style-type: none"> <li>a. Use uninterrupted outlet</li> <li>b. Reset time of day</li> <li>c. Replace PC board</li> </ul>
3. No Softening/filtering display when water is flowing.	<ul style="list-style-type: none"> <li>a. Bypass valve in bypass position.</li> <li>b. Meter connection disconnected.</li> <li>c. Restricted/stalled meter turbine.</li> <li>d. Defective meter.</li> <li>e. Defective PC board.</li> </ul>	<ul style="list-style-type: none"> <li>a. Put bypass valve in service position</li> <li>b. Connect meter to PC board</li> <li>c. Remove meter and check for rotation or foreign material</li> <li>d. Replace meter</li> <li>e. Replace PC board</li> </ul>
4. Control valve regenerates at wrong time of day.	<ul style="list-style-type: none"> <li>a. Power outages</li> <li>b. Time of day not set correctly</li> <li>c. Time of regeneration incorrect</li> <li>d. Control valve set at "on O" (immediate regeneration)</li> <li>e. Control valve set at NORMAL + O</li> </ul>	<ul style="list-style-type: none"> <li>a. Reset control valve to correct time of day</li> <li>b. Reset to correct time of day</li> <li>c. Reset regeneration time</li> <li>d. Check control valve set-up procedure regeneration time option</li> <li>e. Check control valve set-up procedure regeneration time option</li> </ul>
5. ERROR followed by Code number:  <b>Error Code 101</b> – Unable to recognize start of regeneration.  <b>Error Code 102</b> – Unexpected stall.  <b>Error Code 103</b> – Motor ran to long, timed out trying to reach next cycle position.  <b>Error Code 104</b> – Motor ran to long, timed out trying to reach home position.  If other Error Codes display contact the factory.	<ul style="list-style-type: none"> <li>a. Control valve has just been serviced</li> <li>b. Foreign matter is lodged in control valve</li> <li>c. High drive forces on piston</li> <li>d. Control valve piston not in home position</li> <li>e. Motor not inserted fully to engage pinion, motor wires broken or disconnected, motor failure</li> <li>f. Drive gear label dirty or damaged, missing or broken gear</li> <li>g. Drive bracket incorrectly aligned to back plate</li> <li>h. PC board is damaged or defective</li> <li>i. PC board incorrectly aligned to drive bracket</li> </ul>	<ul style="list-style-type: none"> <li>a. Press NEXT and REGEN for 3 seconds or unplug power source jack (black wire) and plug back in to reset control valve.</li> <li>b. Check piston and spacer stack assembly for foreign matter.</li> <li>c. Replace piston (s) and spacer stack assembly.</li> <li>d. Press NEXT and REGEN for 3 seconds or unplug power source jack (black wire) and plug back in to reset control valve.</li> <li>e. Check motor and wiring. Replace motor if necessary.</li> <li>f. Replace or clean drive gear.</li> <li>g. Reset drive bracket properly.</li> <li>h. Replace PC board.</li> <li>i. Ensure PC board is correctly snapped onto drive bracket.</li> </ul>
6. Control valve stalled in regeneration.	<ul style="list-style-type: none"> <li>a. Motor not operating</li> <li>b. No electric power at outlet</li> <li>c. Defective transformer</li> <li>d. Defective PC board</li> <li>e. Broken drive gear or drive cap assembly</li> <li>f. Broken piston retainer</li> <li>g. Broken main or regenerant piston</li> </ul>	<ul style="list-style-type: none"> <li>a. Replace motor</li> <li>b. Repair outlet or use working outlet</li> <li>c. Replace transformer</li> <li>d. Replace PC board</li> <li>e. Replace drive gear or drive cap assembly</li> <li>f. Replace drive cap assembly</li> <li>g. Replace main or regenerant piston</li> </ul>
7. Control valve does not regenerate automatically when REGEN button is depressed and held.	<ul style="list-style-type: none"> <li>a. Transformer unplugged</li> <li>b. No electric power at outlet</li> <li>c. Broken drive gear or drive cap assembly</li> <li>d. Defective PC board</li> </ul>	<ul style="list-style-type: none"> <li>a. Connect transformer</li> <li>b. Repair outlet or use working outlet</li> <li>c. Replace drive gear or drive cap assembly</li> <li>d. Replace PC board</li> </ul>
8. Control valve does not regenerate automatically but does when REGEN button is depressed.	<ul style="list-style-type: none"> <li>a. Bypass valve in bypass position</li> <li>b. Meter connection disconnected</li> <li>c. Restricted/stalled meter turbine</li> <li>d. Defective meter</li> <li>e. Defective PC board</li> <li>f. Set-up error</li> </ul>	<ul style="list-style-type: none"> <li>a. Put control valve in service piston</li> <li>b. Connect meter to PC board</li> <li>c. Remove meter and check for rotation or foreign matter</li> <li>d. Replace meter</li> <li>e. Replace PC board</li> <li>f. Check control valve set-up procedure</li> </ul>
9. Time of day flashes on and off.	<ul style="list-style-type: none"> <li>a. Power has been out more than two hours, the transformer was unplugged and then plugged back into the wall outlet, the transformer plug was unplugged and then plugged back into the board or the NEXT and REGEN buttons were pressed to reset the valve.</li> </ul>	<ul style="list-style-type: none"> <li>a. Reset the time of day</li> </ul>



A DIVISION OF C-B TOOL CO.

1340 MANHEIM PIKE • LANCASTER PA 17601-3196 • TEL:717-397-3521 • FAX: 717-392-0266

www.lancasterwatergroup.com • E-mail: info@lancasterwatergroup.com