

Hydro Massage Products

Owner's Manual & Installation Guide

APRIL 2014



IMPORTANT: Read all instructions before proceeding with installation.

INSPECT entire unit to ensure it is not damaged and is the correct model, size and color. Verify it has all the features and options originally ordered.

All whirlpools **MUST BE TESTED** before or during rough installation.

Please read the operation and maintenance instructions. It contains important information about how to operate and maintain your jetted bath properly and safely.

RECORD YOUR MODEL INFORMATION

Builder/Dealer/Name _____

Address _____

Phone No. _____

Model No. _____

Serial No. _____

Purchase Date _____

Hydro Massage Products, 505 Nucla Way, Aurora Colorado 80011

Phone: (303) 341-1845 • Fax: (303) 341-1850

www.hydrmassageproducts.com • service@hydrmassageproducts.com

INSTALLATION AND OPERATION GUIDELINES

Read all instructions before installing tub. Installer / product owner is responsible for complying with all state and local codes. Warranty coverage will be void if unit is not tested and installed per the enclosed instructions. Hydro Massage strongly recommends using licensed professionals to install this product. Warning: Certain cleaning products will permanently damage the acrylic surface. Read product label carefully before using any cleaning products. Never use anything abrasive, aerosol sprays or any product that is described as "scrubbing bubbles".

BEFORE INSTALLING:

Inspect tub thoroughly

1. Damage from shipping or delivery must be reported to carrier immediately. Do not install damaged tub. Hydro Massage Products is not responsible for damage occurring in transit.
2. Factory defect must be reported to factory before tub is installed. Defects or damage claimed after installation will be excluded from warranty.
3. Important – Measure tub on site carefully. Specifications are subject to change without notice. Hydro Massage Products is NOT responsible for any preparatory labor or materials.

ATTENTION INSTALLER!

THIS TUB MUST BE TESTED FOR OPERATION AND LEAKS PRIOR TO ENCLOSURE OF SURROUNDING AREAS. FAILURE TO DO SO WILL VOID WARRANTY. THIS TUB WAS WATER TESTED AT THE FACTORY AND FOUND TO BE FULLY OPERATIONAL AND LEAK-FREE PRIOR TO SHIPPING. FREIGHT, HANDLING AND JOB SITE EXPOSURE MAY HAVE DETERIORATED THE TUB'S CONDITION. IT IS THE RESPONSIBILITY OF THE INSTALLER TO THOROUGHLY TEST THE UNIT PRIOR TO INSTALLATION. TUBS ARE INTENDED FOR INDOOR USE ONLY. TUBS ARE WARRANTED FOR INDOOR INSTALLATION IN A CLIMATE CONTROLLED ENVIRONMENT ONLY.

TEST PROCEDURES

1. Place the tub on a flat surface such as a driveway.
2. Seal the drain with tape.
3. Fill tub to overflow and allow tub to stand for five minutes without any components running. NOTE: the overflow is a plumbing device designed to prevent water from reaching a certain level in your tub. DO NOT, under any circumstances, tape off or block the overflow in any way. Any controls located above the normal water line are designed to be water-resistant, not water-proof. The controls will not leak under normal usage, however, they are not warranted against leaks when improperly used or subjected to conditions for which they were not designed.
4. Plug the components into a 110v GFCI outlet. Start the equipment and check for leaks by examining the area underneath and surrounding the tub.
5. Check that all optional equipment is functioning properly and that the features on the tub match exactly what was ordered.
6. If any leaks or operating problems are discovered, do not complete installation until problems are resolved. Hydro Massage Products will not be responsible for leaks claimed after the tub is installed, or any costs involved with removing or reinstalling the tub or the costs of any surrounding materials or labor.
7. Do not put blow-in or fiberglass insulation around or near the motors. Doing so will void the warranty.

Always protect tub from construction damage by using a protective cover. Damage, including chips and scratches, incurred at the job-site is excluded from warranty, but may be repaired by qualified technician at the owner's expense. Do not stand in the tub or store materials in the tub during construction. Proper waste and overflow installation is the responsibility of the installer. Hydro Massage Products does not warrant leaks associated with improper waste and overflow installation.

ATTENTION INSTALLER!

Access must be provided to all electrical components. The access panel(s) must have a minimum size of 18" x 18" for installation and future servicing of the equipment.

Hydro Massage Products will not authorize any service unless clear access is available. Access from a crawlspace or incomplete access to all equipment may result in warranty claims being denied.

Congratulations

On the purchase of your Hydro Massage bath tub!

Hydro Massage Products supports your purchase with strong commitment to quality and customer satisfaction.

Please read and follow all of the instructions contained in this Owner's Manual before installing, operating or maintaining your whirlpool. In addition, you should refer to these instructions during the life of your whirlpool. Failure to comply with these instructions and registration of this product may invalidate your warranty. If you have any questions concerning installation, operation, maintenance, or any other aspect of your whirlpool after reading this manual or during the life of your whirlpool, please contact us.

Hydro Massage Products customer service: (303) 341-1845: (Please be sure to consult the Troubleshooting Guide before calling)

NOTE: Only a qualified electrician, technician or plumber should perform the installation and service of your whirlpool.

TABLE OF CONTENTS

Safety instructions	1
Installation Instructions	2-5
Walk-In Installation Instructions	6
Free Standing Installation Instructions	
General Guidelines	7
Natura, and Tahoe 7236	see insert
Oasis	8-9
Bello, Ovale, Rosabella and Tahoe 7242	10-11
Remote Blower	12
Plumbing	13
Electrical	14
Hydro Sounds Installation	15

OPERATING INSTRUCTIONS

For all Whirlpool Bath Systems	16
For Hydro Bronze, Silver & Gold Series	17
For Hydro Platinum Series	18
For Silver Air Systems	19
For Gold & Platinum Air Systems	20
For Silver Combination Systems	21
For Gold Combination Systems	22
For Platinum Combination Systems	23-24
Hydro Scents Aromatherapy	25
HydroClean Sanitation System	25
Inline Maintenance Heater	25
Mood Light and Chromatherapy	26
User Maintenance Instructions	27-28
Warranty	29
Troubleshooting Guide	30-31
Product Registration	31

IMPORTANT SAFETY INSTRUCTIONS

INSTRUCTIONS PERTAINING TO A RISK OF FIRE, ELECTRIC SHOCK, OR INJURY TO PERSONS

WARNING:

When using this unit, basic precautions should always be followed, including the following:

1. **READ AND FOLLOW ALL INSTRUCTIONS**
2. **DANGER**—To reduce the risk of injury, do not permit children to use this unit unless they are closely supervised at all times.
3. Use this unit only for its intended use as described in this manual. Do not use attachments not recommended by the manufacturer.
4. Never drop or insert any object into any opening.
5. Do not operate this unit without the guard over the suction fitting.
6. The unit must be connected only to a supply circuit that is protected by a ground-fault circuit-interrupter (GFCI). Such a GFCI should be provided by the installer and should interrupt power. Push the reset button. Power should be restored. If the GFCI fails to operate in this manner, the GFCI is defective. If the GFCI interrupts power to the bathtub without the test button being pushed, a ground current is flowing, indicating the possibility of an electric shock. Do not use this Hydro Massage bathtub. Disconnect the bathtub and have the problem corrected by a qualified service representative before using.
7. (For permanently connected units) A green-colored terminal (or wire connector marked 'G', 'GR', 'Ground', or 'Grounding') is provided within the terminal compartment. To reduce the risk of electric shock, connect this terminal or connector to the grounding terminal of your electric service or supply panel with a conductor equivalent in size to the circuit connectors supplying this equipment.
8. **A thermostatic mixing valve is required.** Section 414.5 of the 2009 Uniform Plumbing Codes require that the maximum hot water temperature discharging from the bathtub and/or whirlpool bathtub filler shall be limited to 120°F (49°C) by a device that conforms to ASSE 1070 or CSAB125.3. The water heater thermostat shall not be considered a control for meeting this provision.
9. **SAVE THESE INSTRUCTIONS.**

WARNING... Prolonged immersion in hot water may induce extremely high body temperature (hyperthermia). Hyperthermia occurs when the internal temperature of the body reaches a level several degrees above the normal body temperature of 98.6° F. The symptoms of hyperthermia include an increase in the internal temperature of the body, dizziness, lethargy, drowsiness and fainting. The effects of Hyperthermia include:

1. Failure to perceive heat
2. Failure to recognize the need to exit the tub
3. Unawareness of impending hazard
4. Fetal damage in pregnant women
5. Physical inability to exit the tub, and
6. Unconsciousness resulting in the danger of drowning

WARNING: The use of alcohol, drugs, or medication can greatly increase the risk of fatal hyperthermia.

INSTALLATION INSTRUCTIONS

DO NOT LIFT THE HYDRO MASSAGE PRODUCTS BATH BY THE PLUMBING AT ANY TIME

INSTALLATION

1. Unpack the contents carefully and inspect the bath to verify that it is the correct model, features, and color, the pump is the correct size ordered and check for visible defects of damage. If there are problems DO NOT INSTALL. Contact the dealer/manufacturer for further instruction.
2. Construct a finish frame under the bath rim to support the bath lip and keep the deck level, which will assist water draining from the deck back into the bath. (Note: this is not required for walk-in baths with metal support structure.) An access panel MUST be provided for pump/control and/or blower/control to enable final electrical connections and service. The minimum recommended access panel(s) size is 18" x 18" next to the pump(s) so the unit(s) can be removed.
3. Drain and overflow assembly- The plumber should connect the drain and overflow assemblies per the manufacturer's instructions. The bath may then be positioned, leveled and connected to the waste. This should be done to local building codes by qualified personnel.

WARNING: VERIFICATION OF ELECTRICAL REQUIREMENTS MUST BE MADE BEFORE INSTALLATION.

DANGER- RISK OF ELECTRIC SHOCK. Connect only to a circuit protected by a Ground-Fault Circuit-Interrupter(s) (GFCI) with 120volt, 20amp, 60hertz electrical service with a service grounded receptacle dedicated for use by the bath.

4. Electrical Service(s)-A licensed electrician must provide the electrical service protected by a Ground-Fault Circuit-Interrupter(s) (GFCI) with 120volt, 20amp, 60hertz electrical service with a service grounded receptacle dedicated for use by the bath. Please refer to model specifications for electrical requirement.
5. GROUNDING IS REQUIRED. The unit should be installed by a qualified service representative and grounded.

ALL LOCAL AND STATE ELECTRICAL AND PLUMBING CODES MUST BE OBSERVED. IT IS THE RESPONSIBILITY OF THE INSTALLER/ OWNER TO DETERMINE SPECIFIC CODE COMPLIANCE PRIOR TO INSTALLATION OF THE PRODUCT.

6. Water testing- Before installing or finishing the installation, it is required that the bath be water tested and the plumbing checked for leaks. Close the drain and fill the bath with water to the overflow outlet. Check the exposed piping and especially the union connections for signs of leakage. Allow the bath to sit for an additional 30 minutes and re-inspect. Turn the pump and/or blower on and operate all features and look for signs of leakage for 30 minutes. Turn the pump and/or blower off and drain the water.

HYDRO MASSAGE PRODUCTS WILL NOT BE RESPONSIBLE FOR WATER DAMAGE OF ANY KIND IN CONNECTION WITH ONE OF OUR WHIRLPOOL BATHS.

INSTALLATION INSTRUCTIONS

Continued

WARNING: Whirlpool pump and piping are factory assembled. Relocation of pump or other modifications could adversely affect the performance and safe operation of this whirlpool. Hydro Massage Products shall not be liable under its warranty or otherwise for personal injury or damage caused by such unauthorized modification.

QUIETNESS OF OPERATION—Hydro Massage Products has engineered their whirlpool baths from the base to the lip to ensure quality, value, functional design and maximum bathing comfort. However installations are accountable for as much as 50% of a tub's operating quietness. Please ensure the following:

Verify the floor structure is adequate to support the whirlpool with bather(s). Insulate the tub surround and leave a dead air space around the pump and tub. Leave 1/8" to 3/16" gap between tub lip and surround.

WARNING...Refer all plumbing or electrical repair to a qualified service technician. DO NOT ATTEMPT TO RESOLVE THE PROBLEM. Attempts to repair plumbing or electrical equipment by a non-qualified service technician can result in danger of electrical shock or damage to the unit. Call your dealer for the name of the qualified service technician near you.

The user should do no servicing of this product. There are no user serviceable parts. All controls and air switches are located on the deck of the tub. These are the only controls that should be used by the consumer. Do not change or alter any of these controls under any circumstances. Motors are self-lubricating and no lubrication is required. This unit should only be serviced by a qualified service representative.

STRUCTURAL PREPARATION

- Literature dimensions are for reference only. Installation dimensions should be taken directly from the tub. An access panel of 18" x 18" minimum must be provided at the pump end of the whirlpool, allowing sufficient clearance to make final connections and for servicing the pump and power panel. Access may be through the wall or platform apron at the end of the unit. In the case of sunken installations, access should be made through the ceiling below.
- The bath should remain in its shipping carton/packaging until time of installation.
- Install the drain fitting to the bath. THE DRAIN FITTING SOMETIMES WILL PROTRUDE BELOW THE BASE OF THE TUB APPROXIMATELY 1 1/2". Clearance must be provided for the drain by cutting away the sub floor (where possible) or by blocking below the tub as may be required. WARNING: factory skirts do not allow for blocking up of the tub base. All blocking must be solid and provide uniform support to the EZ Level Base or Legs.
- Tub must rest entirely on the EZ Level Base or Legs. DO NOT SUPPORT THE WEIGHT OF THE TUB BY THE RIM. To reduce vibration noise, a bed of wet mortar in area where tub is to be installed is optional. Carefully level unit, ensuring that uniform support is given to all areas of the base and that no portion of the lip is bearing weight. DO NOT USE MORTAR IF YOUR TUB HAS THE DELUXE AIR SYSTEMS WITH JETS ON THE BOTTOM OF THE BATH. The EZ level base will support the unit with Deluxe Air Systems.
- Frame out under the tub rim as shown in one of the illustrations below. NOTE: Due to the variety of installations possible, framing procedures other than those described may be required. Plumb in selected location using a level. Level front to back and across on both sides. A ledge under the rim, or an apron without a ledge may be constructed as required (see diagram 1A & 1B). Where installations will be against a wall, stud wall framing should run full length to the floor (see diagram 1C or 1D). Install tub firmly against sheathing as indicated with blocking below rim to prevent deflection or movement of tub. To prevent a rocking movement of tub after installation, it is important to have rim in contact, but NOT supported by blocking material. When placing the tub on a platform or cut out (see diagram 1A), the opening should be 2" smaller than the specified rim dimensions. Extreme care must be taken in this type of installation to ensure the tub will come to rest entirely on the base. **WE DO NOT RECOMMEND DECK CUT OUT BE DONE UNTIL TUB IS ON SITE**

IF YOU HAVE PURCHASED A WHIRLPOOL WITH AN INSTALLED TILE FLANGE, PROCEED AS FOLLOWS

CAUTION: THE TILE FLANGE DOES NOT SUPPORT THE TUB! A ledger board must be provided under the bath rim as indicated in the installation instructions. Take care to ensure the tub is not hanging from the ledger boards, as this will void your warranty. PRE DRILL THE FLANGE and use nails or screws to secure the flange into the studs around the bath. Oversize the holes slightly to insure fastener does not damage tub flange. Install water resistant drywall against the tile flange and 1/8"-1" above the top of the whirlpool deck. Install the tile or other finishing materials. Apply a second bead of silicone sealant between the first course of tile and the bath deck.

TYPICAL DROPIN/ISLAND INSTALLATION

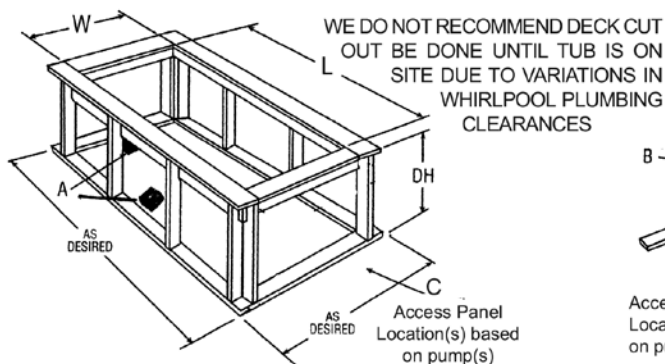

TYPICAL ALCOVE INSTALLATION

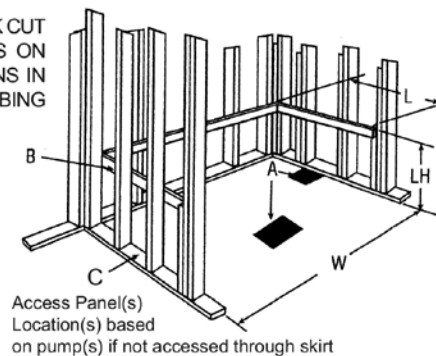

All dimensions should be taken from tub at job site and adjusted as necessary. Always refer to the model specification sheet. Specifications subject to change without notice and installations vary based on model, and whirlpool plumbing systems.

L=1-1.5" less than overall length of tub
 W=1-1.5" less than overall width of tub
 DH=up to 1/2" higher than deck height
 A=6" x 12" waste and over flow cut out
 C=18" x 18" pump access 1 or 2, or 3 to allow removal of pump(s)

L=2" less than width for ledger board
 W=1/8" – 1/4" larger than length of tub
 LH=up to 1/2" higher than deck height
 A=6" x 12" waste and over flow cut out
 B=1" x 3" leveled ledger supports
 C=18" x 18" pump access 1 or 2, or 3 to allow removal of pump(s)

NOTE: Before tub is used, the whirlpool system should be cleaned and disinfected. For proper procedure, please see the Maintenance section of this manual pages 27-28.

TYPICAL METHODS OF SEALING & FINISHING

MAKE SURE INTERIOR OF TUB IS PROTECTED DURING FINISHING

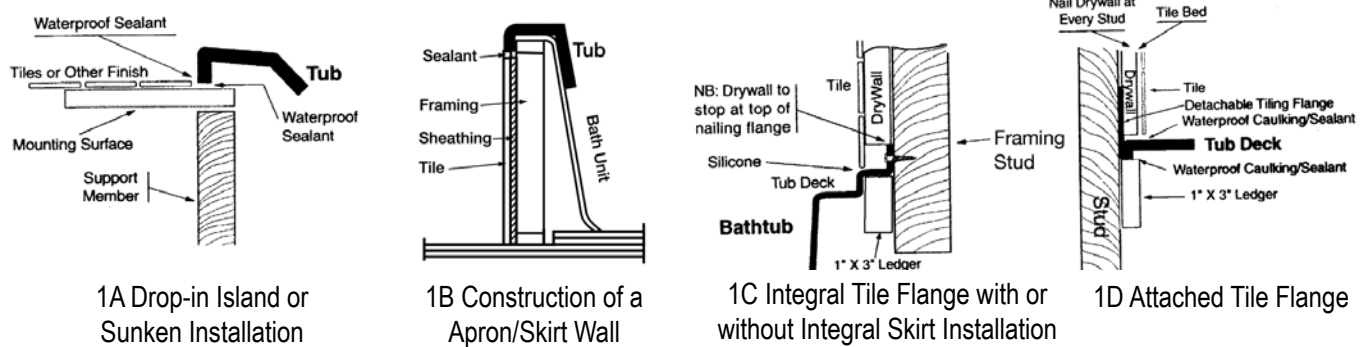

1A Drop-in Island or Sunken Installation

1B Construction of an Apron/Skirt Wall

1C Integral Tile Flange with or without Integral Skirt Installation

1D Attached Tile Flange

INTEGRALLY SKIRTED AND/OR FLANGED WHIRLPOOLS

Installation Procedures:

IMPORTANT!!! Before installation begins, make sure that:

Framed in alcove is of proper size, square and plumb; wall and floors meet fire safety requirements of local building code and/or FHA/HUD minimum property standards.

1. To avoid obstruction during installation, make sure water lines, spout pipes and valve plumbing do not project into alcove.
2. Ledger Strip: Fasten a 1" x 3" (25mm x 75mm) ledger strip along rear and both sides of alcove.
3. If optional mortar bed is desired, mix a 3-gallon bucket of non-shrinking mortar or plaster into a paste. Place three or four mounds of plaster away from drain hole in a line or square, approximately twice as high as the cavity under the tub bottom. Place a layer of plastic on top of the mounds. Before moving unit into alcove see and follow enclosed Electrical Connections Procedures (electrical and air tube hook ups will be difficult to perform if unit is installed first). **DO NOT USE MORTAR IF YOUR TUB HAS THE DELUXE AIR SYSTEMS WITH JETS ON THE BOTTOM OF THE BATH.** The EZ level base will support the unit with Deluxe Air Systems.
4. Place tub into alcove with front skirt firmly on floor and either depress into plaster mounds or assure that EZ Level Feet are firmly on floor. Make certain that back ledge of tub rests firmly on ledger strip.
5. Pre drill flange then using 1 1/2" (40mm) galvanized roof nails or washer head screws: (a) spot fasten the two bottom corners and the two top corners of the vertical side nailing flanges. (b) fasten at each stud through the top sides flanges and back flange, working from both ends toward back center (c) complete fastening vertical side flanges. Pre drill holes through flange 1/8" larger than diameter of screw.
6. When other than scratch coat is used, furring strips as thick as nailing flanges are recommended for installation on studs above the installed tub to assure drywall will be flush.
7. Removable skirt panel for integrally skirted models: These models are sometimes offered with removable access panels. They provide a flush to wall installation (sheet rock overlaps skirt while still providing access). The skirt features a decorative removable panel enabling easy access to motor, pump and electrical hook ups. Pre mounted interlocking nylon fasteners (Velcro) or screws with caps enable simple and quick removal of skirt access panel. A small bead of color matched or clear silicone is required around the perimeter of the access panel to finish the installation.

IMPORTANT: Before installation of the access panel, fill the unit, test the whirlpool system for proper operation and check for leaks, then drain.

Protect interior of tub throughout installation procedures.

Framing and supports will vary according to the Model selected. Follow dimensions for your specific unit.

Plumbing connection – (spout, handles, valves, etc.) should be made after unit is installed. When mounting fittings on unit, drill holes from finished surface, using appropriate sized hole saw with fine tooth or abrasive grit cutting edge.

WALK-IN INSTALLATION PROCEDURES:

1. Bathtub must be set on a solid flat surface, either concrete slab or a minimum 3/4" plywood sub-floor.
2. All adjustable feet must firmly contact with the floor.
3. The bath must be completely level from side to side and front to back on the top lip of the bath.
4. Plumbing hardware (faucet, hoses, and waste/overflow) should be installed prior to setting tub in-place.
5. Filler panel is used for 60" opening installations. (if applicable)
6. The drain body is to be installed between the drain shoe and the drain tee. (if applicable)

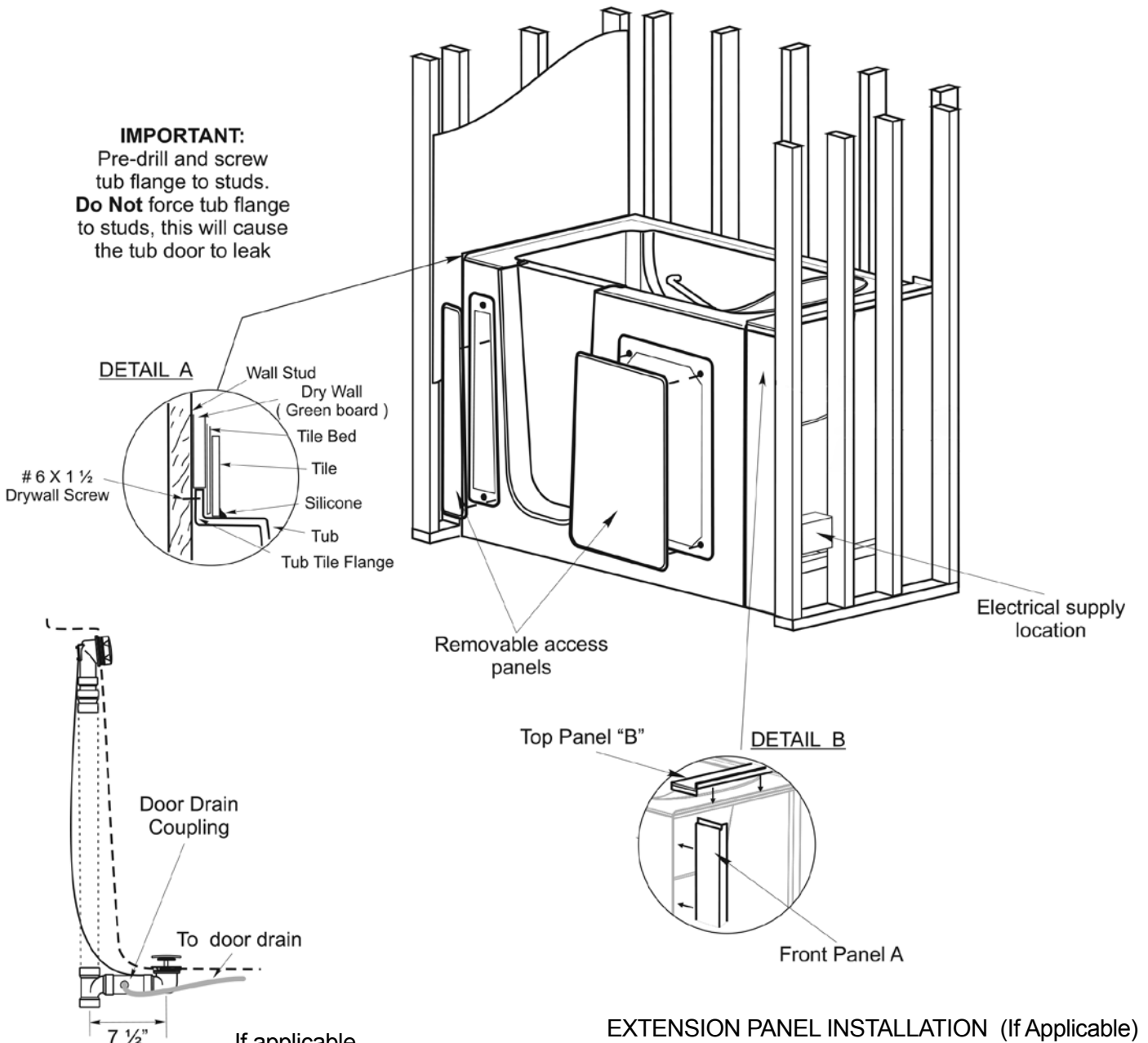

If applicable,
The drain body
and hose must be
installed horizontal

EXTENSION PANEL INSTALLATION (If Applicable)

- Step 1. Slide front panel A onto front of tub.
- Step 2. Slide top panel B over Tile Flange
- Step 3. Refer to Detail A on fastening flange to studs and sealing

FREESTANDING BATH GENERAL GUIDELINES

For All Models

- Carefully read all instructions before beginning the installation.
- Consult local building codes to assure the installation complies with standards.
- It is always recommended that competent, experienced, licensed contractors do the plumbing and electrical installations.
- For critical rough-in dimensions, we suggest taking the measurements of the actual tub on site. All printed specifications are $\pm 1/2"$ and subject to change without notice.
- Assure that all necessary electrical is roughed in to the appropriate location(s) if applicable. Refer to the specifications of the tub being installed for electrical requirements. If a remote blower location is to be used, 1 of the necessary circuit(s) will be at the location of the blower and the other necessary circuit(s) will be at the tub location.
- Access must be provided for each major unit component if applicable (pump(s), blower, heater, control boxes).
- For installations on slabs or other installations where access from below the tub is impossible, we **require** cutting a hole in the slab or sub-floor large enough that it extends outside the base of the tub. This will allow easier connection of the waste/overflow and then can be re-filled and finished upon completion of installation and testing. (see figures 1-3)
- Remove the unit from it's packaging. Before disposing of the packaging, inspect the unit to be sure it is in good shape. Should inspection reveal any damage or defect in the finish, contact your distributor immediately. The warranty doesn't cover damages or defects in the finish once the unit has been installed. Hydro Massage Products' responsibility for shipping damages ceases once the unit leaves our Colorado facility. All complaints regarding damage due to transport must be made directly to the Freight Company.
- Except for the Ovale, Rosabella and Tahoe 7242 models, plumbing fixtures can not be mounted on the tub deck of Hydro Massage Products' freestanding tubs. Floor or Wall-Mounted fixtures are required.
 1. **Wall-Mounted** – The position of the tub and the reach of the spout are critical. Ensure the spout will extend out far enough to clear the tub flange and the falling water will not hit too high up on the side wall of the tub and splash.
 2. **Floor-Mounted** – Some floor mounted fixtures must be anchored to the tub overflow for stabilization. This is only possible on our Natura and Tahoe 7236 models that utilize exposed overflow kits. The overflow on our other freestanding models is either integral or concealed under the apron of the tub so anchoring to the overflow pipe is not possible and anchoring to the apron of the tub is not recommended. Many floor mounted kits (with minor modification) can be mounted to the wall, rather than the overflow pipe, for stabilization.

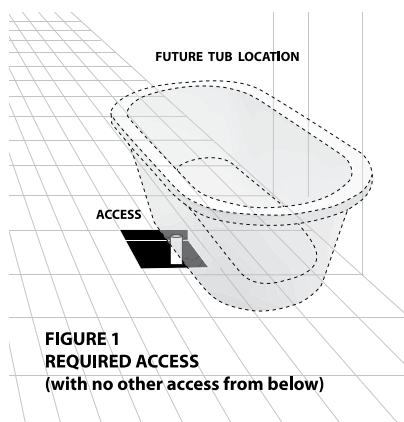

FREESTANDING INSTALLATION INSTRUCTIONS

for Oasis

For installations on slabs or other installations where access from below the tub is impossible, we require cutting a hole in the slab or sub-floor large enough that it extends outside the base of the tub. This will allow easier connection of the waste/overflow and then can be re-filled and finished upon completion of installation and testing. (See General Guidelines, page 7)

1. Clean, level, and prepare the floor for installation.
2. Place the unit in the exact installed position on the floor and trace the outline of the bath with a pencil or any erasable marking (figure 1).
3. Determine the location of the drain pipe, and air line (on units with remote blower location on Air Massage Systems) on the floor by taking measurements of the drain and waste location underneath the unit (figure 2).

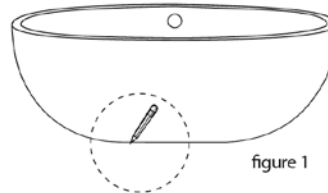

figure 1

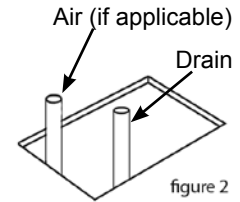

figure 2

NOTE: Air and drain connections will vary.



figure 3

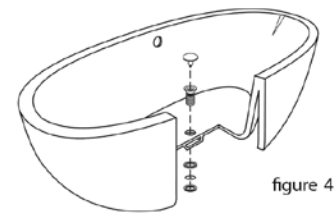

figure 4

Note: Drain and waste locations will vary by model.

4. Using a blanket, or other clean protective surface, turn the unit on its side so that the unit is properly supported during drain installation.
5. Clean the drain hole area in preparation of setting the drain. The area should be dry and free of any debris.

INSTALL DRAIN

Drain Hardware

6. Apply a bead of clear RTV silicone or plumbers putty around the Drain Body and pass it through the drain hole (figure 3).
7. Apply plumbers putty to the Washer and slide it over the bottom of the Drain Body (figure 3).
8. Slide the paper washer over the drain body.
9. Attach the Drain Body Nut on the Drain Body and tighten until the Nut and Washer have created a seal with the bottom of the bathtub. DO NOT OVER TIGHTEN (figure 4).

PREPARE TAIL PIECE

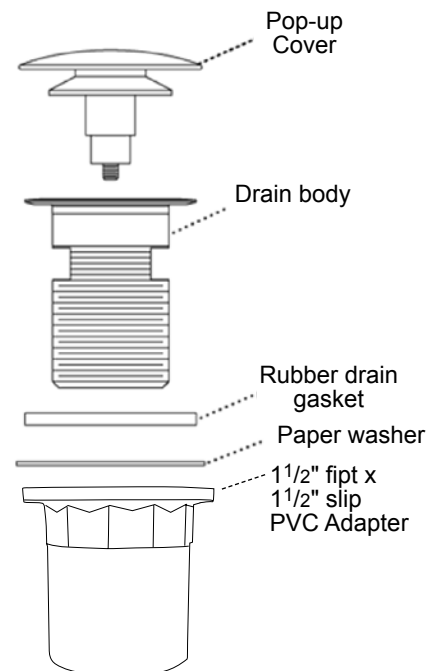

FREESTANDING INSTALLATION INSTRUCTIONS

for Oasis

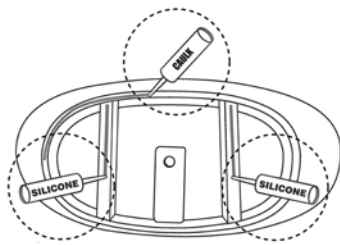

figure 6

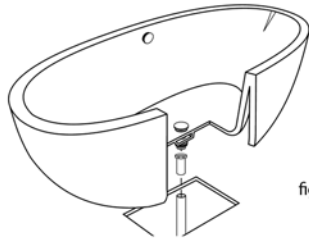

figure 7

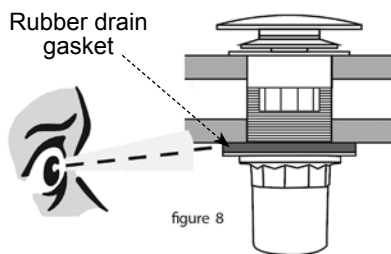

figure 8

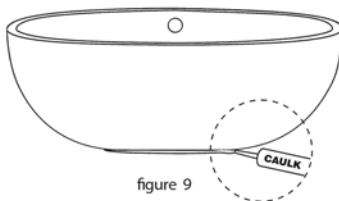

figure 9

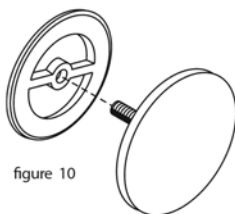

figure 10

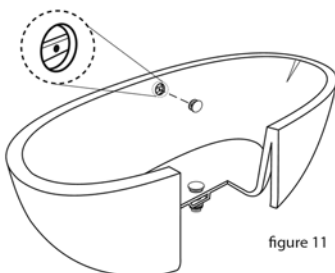

figure 11

Most parts involved in tail piece installation are provided by the installer.

10. Hydro Massage Products will provide a 1.5" fip t x 1.5" slip PVC adapter to connect drain body to P-Trap.
11. Apply a small bead of RTV silicone to threads of drain body and screw on PVC adapter. Hand tighten only, being sure not to twist drain body in tub.
12. Use whatever PVC fittings and pipe as necessary (provided by installer) to plumb PVC adapter to P-trap.

INSTALL BATHTUB

NOTE: Remote blower installations continue on pages 12 then return to step 13

13. Apply a generous bead of adhesive or silicone to the bottom of the tub supports (figure 6).
14. Then apply a bead of tub and tile caulk around the edge of the base (figure 6).
15. **Carefully** set tub into position (figure 7) and connect the drain hardware (previously installed). Finish the installation of the tail-piece.

COMPLETE BATHTUB INSTALLATION

16. Fill the tub with water to the overflow and allow to set for 20 minutes, then drain the tub while inspecting the waste connections below the floor for leaks. Access from below will be necessary for this step (figure 8).
17. With the tub now in place, wipe off any excess tub and tile caulk and adhesive where the tub meets the floor.
18. Run a bead of tub and tile caulk around the bottom edge of the tub where it meets the floor. Wipe off any excess caulk with a wet cloth (figure 9)

INSTALL OVERFLOW HARDWARE

19. Place the Back Plate over the screw of the Overflow Cover (figure 10)
20. Then align the Overflow Cover with the bar (installed at the factory in the overflow hole (figure 11).
21. Carefully hand tighten the Overflow Cover until it stops. **DO NOT OVER TIGHTEN.**

INSTALLATION WITHOUT ACCESS TO BOTTOM OF UNIT

FREESTANDING INSTALLATION INSTRUCTIONS

for Ovale, Rosabella and Tahoe 7242 Models

For installations on slabs or other installations where access from below the tub is impossible, we require cutting a hole in the slab or sub-floor large enough that it extends outside the base of the tub. This will allow easier connection of the waste/overflow and then can be re-filled and finished upon completion of installation and testing. (See General Guidelines, page 7)

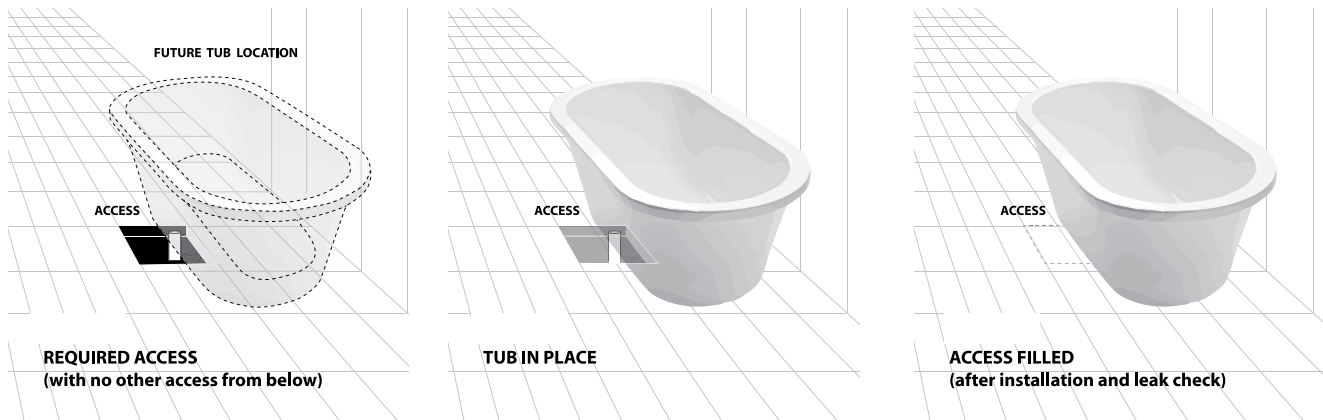

PREPARATION

1. Clean, level, and prepare the floor for installation.
2. Place the unit in the exact installed position on the floor and trace the outline of the bath with a pencil or any erasable marking pen. While the unit is in position, ensure it is level in both directions for proper drainage.
3. Using a blanket, cardboard, or other clean protective Wooden Blocks surface, turn the unit upside down and remove the screws and/or wooden blocks holding the apron and the bathtub together (figure 1).
4. Separate bathtub from apron.
5. Install all plumbing and drainage before setting bathtub into apron. **Note: due to limited space between the apron and tub shell, use care when selecting your drain kit if not provided by Hydro Massage Products.**

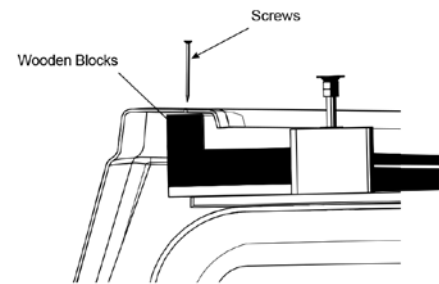

Figure 1

Important! Faucet elements must be attached to, at least, a 24" – 30" length of 1/2" hose so that bathtub can be lifted if ever necessary.

6. Place apron in outline marked in step 2. Drill 4 over sized holes in bottom of apron large enough to accommodate whatever size screws will be used to fasten apron to floor without cracking the acrylic. Application of a silicone sealant under the apron is optional.
7. Secure apron to floor. **Do not over tighten fasteners, causing acrylic to crack on the apron. Hydro Massage Products will not warranty acrylic damage done during this step.**

FREESTANDING INSTALLATION INSTRUCTIONS

for Ovale, Rosabella and Tahoe 7242 Models

INSTALL BATHTUB

NOTE: Remote blower installations continue on page 12 and then return to step 8.

8. Apply a small bead of silicone to leveling feet to prevent lateral movement or shifting of tub inside of tub surround. (figure 2A)
9. Rest a 4x4 on each end of tub to provide enough clearance to attach water supply lines. Open supply valves to check for leaks.
10. Remove 4x4's and **gently** lower bathtub into apron, making sure **all** legs under the tub rest firmly on the floor (figure 2B).
11. Connect waste/overflow per local standards. *If there is no access to tub from below, it may be necessary to connect waste/overflow assembly to house plumbing before step 8, then securing drain fitting and overflow to tub after tub is set in apron (figure 3).*



Figure 2A

Silicone On Leveling Leg

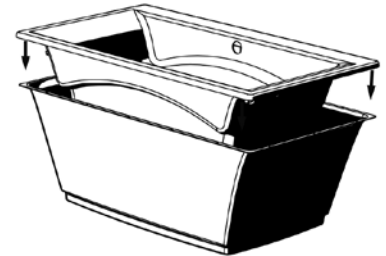

Figure 2B

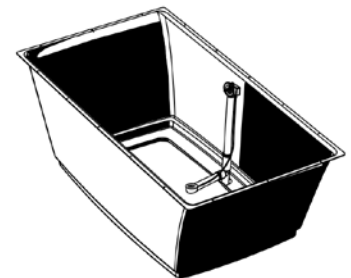

Figure 3

COMPLETE BATHTUB INSTALLATION

12. Fill the tub with water to the overflow and allow to set for 20 minutes, then drain the tub while inspecting the waste connections below the floor for leaks. Access from below will be necessary for this step (figure 4).
13. With the tub now in place, wipe off any excess silicone where the tub meets the floor, if used.
14. Run a bead of tub and tile caulk around the bottom edge of the tub where it meets the floor. Wipe off any excess caulk with a wet cloth.

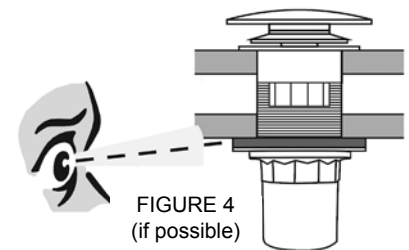

FIGURE 4
(if possible)

Applicable for the Rosabella and Tahoe 7242 models. The Ovale uses a deluxe cable drain and PVC adapter is not necessary

REMOTE BLOWER INSTALLATION

For All Models

For ease of installation of remote equipment and air line connections, it is recommended there be access of some kind to the underside of the bathtub, either from above or below the sub-floor.

PREPARATION

1. Determine location for blower and verify that access to bathtub connections and remote location will be possible after bathtub is installed. Blower location must be within 15 feet of tub, with a maximum of (5) 90° elbows. A 15 amp GFCI protected outlet must be installed within 2 feet of blower location.

NOTE: Air blowers do not require a bonding conductor.

2. The air blower is shipped loose with the tub. The control pad, control pad cable and flexible 1" blower hose with 1-1/2" PVC bushing are connected to the tub from the factory and should not be removed.
3. Hydro Massage Products recommends using 1-1/2" schedule 40 PVC to run from the connection point at the bathtub to the blower. The 1-1/2" PVC will connect directly into the discharge end of the blower and should be secured with a stainless steel screw. **NOTE: Do not glue blower to the PVC.** Use care not to crush or kink any connections.
4. Pipe insulation may be used on the air line between the blower and the tub to help retain the heat from the blower. Do not use insulation within 12" of the blower. Do not wrap insulation around the blower or use blown-in insulation within 24" of the blower as this will cause the equipment to fail. The blower needs sufficient air space surrounding it for circulation.
5. The control pad cable provided on the tub is 8' long. Should an extension cable and connector be necessary, it can be purchased from our Service Department by calling 888-409-8860.
6. Once air line and control cable are connected to the blower, plug the blower into the outlet and test for proper operation before completing installation. Note: after the blower is turned off, the light on the control pad will be flashing, indicating the purge cycle is activated. The blower will run for 1-2 minutes approximately 10 minutes after the blower was last turned off.
7. Complete bathtub installation.

PLUMBING

After securing tub in place, waste and overflow, water spout and valves are installed per normal plumbing procedures, in accordance with all state and local standards.

Install standard 1 1/2" trap to drain and overflow. Before proceeding, make final operational check by filling tub with water to overflow and operate pump for 30 minutes. Check for leaks carefully both while pump is running and while turned off. Allow water to stand in tub for at least 30 minutes before draining. **HYDRO MASSAGE PRODUCTS WILL NOT BE RESPONSIBLE FOR WATER DAMAGE OF ANY KIND IN CONNECTION WITH ONE OF OUR WHIRLPOOL BATHS.**

When selecting fill spout location, check to ensure that the spout is long enough to clear the tub rim from its desired location. If installation is to be on the tub deck, check the backside of the tub for adequate space for connection to water lines before drilling or cutting tub.

WARNING: HEATER AND ELECTRICAL INSTALL: A service access panel of minimum of an 18" square must be provided adjacent to heater/pump assembly.

ELECTRICAL

WARNING: ALL ELECTRICAL CONNECTIONS SHOULD BE MADE BY A LICENSED, LOCALLY CERTIFIED ELECTRICIAN. IN ACCORDANCE WITH THE REQUIREMENTS OF THE NATIONAL ELECTRICAL CODES AND PROCEDURES. REFER TO SPECIFIC SPECIFICATION SHEET FOR ELECTRICAL REQUIREMENTS.

WARNING: WHEN USING ELECTRICAL PRODUCTS, BASIC PRECAUTIONS SHOULD ALWAYS BE FOLLOWED, INCLUDING THE FOLLOWING:

DANGER: RISK OF ELECTRICAL SHOCK!! This unit REQUIRES one or more dedicated circuits, protected by a GROUND FAULT CIRCUIT INTERRUPTER (GFCI). A GFCI is not supplied, however we do specify its use. All known code authorities require a GFCI. Rough in wiring to pump(s) and/or heater on dedicated 120v 20-amp GFCI protected circuit(s). Please refer to specifications sheet for bath requirements.

BONDING WIRE: Grounding is required. The unit should be installed by a qualified Electrician and grounded as specified. For built in and custom units, install a permanent access for servicing.

WARNING: Risk of electrocution-All electrical connections should be performed by a licensed Electrician in compliance with local and national codes. In addition, a GFCI must protect all branch circuits to the whirlpool and every electrical component must be grounded. Run the required number of 120 volt 20 amp branch circuit(s) to a junction box within 2' (24 inches) of the whirlpool pump or heater. The branch circuit(s) MUST BE GFCI PROTECTED. Refer to the model specification sheet for the specific number and size of the GFCI circuits required. Use copper conductors only. Insure the pump is properly grounded and the pump is bonded as required.

CAUTION: Before the use of the pump or heater, test the GFCI for proper operation. The pump or heater should turn off when the GFCI test button is pushed. Note: the heater will only operate if the pump is running.

ELECTRICAL SPECIFICATIONS Dedicated Circuits Required	Combination Platinum	Combination Gold	Combination Silver	Air Platinum	Air Gold	Air Silver	Hydro Platinum	Hydro Gold	Hydro Silver	Soothing Soak
PUMP REQUIRED 120V 20AMP With GFCI	3	2	2	1	1	1	2	1	1	1
INLINE HEATER REQUIRED 120V 20AMP GFCI	1	1	OPT 1				1	1	OPT 1	
WHISPER FLO HEAT SYSTEM 120V 20AMP GFCI				2	OPT 2					
TOTAL DEDICATED CIRCUITS REQUIRED	4	3	2 (OPT 3)	3	1 (OPT 3)	1	3	2	1 (OPT 2)	1

HYDRO SOUNDS MUSIC THERAPY SYSTEM

INSTALLATION INSTRUCTIONS

The Hydro Sounds Music Therapy System saturates your bathing experiencing in the soothing sounds of your favorite music. Hook up to your MP3 player, I Pod or your home sound system and relax to your kind of musical therapy.

The Hydro Sounds Audio Unit produces a tactile sound, much like you'd find in elaborate Home Theater systems, that can not only be heard, but also felt through the body below the water's surface. You'll feel sound and experience music like never before!

Hydro Sounds offers flexibility of installation. The electronic Audio Unit may be wired to your dedicated amplifier or integrated into your zoned home audio system. Below are 2 examples of how Hydro Sounds can be connected. The Audio Unit is installed on the tub at our factory. Just connect the wiring to your amplifier.

NOTE: The amplifier selected (not provided) to power the electronic Audio Unit should be rated between 150-250 Watts per channel at 4 ohms, or 75-125 Watts per channel at 8 ohms.

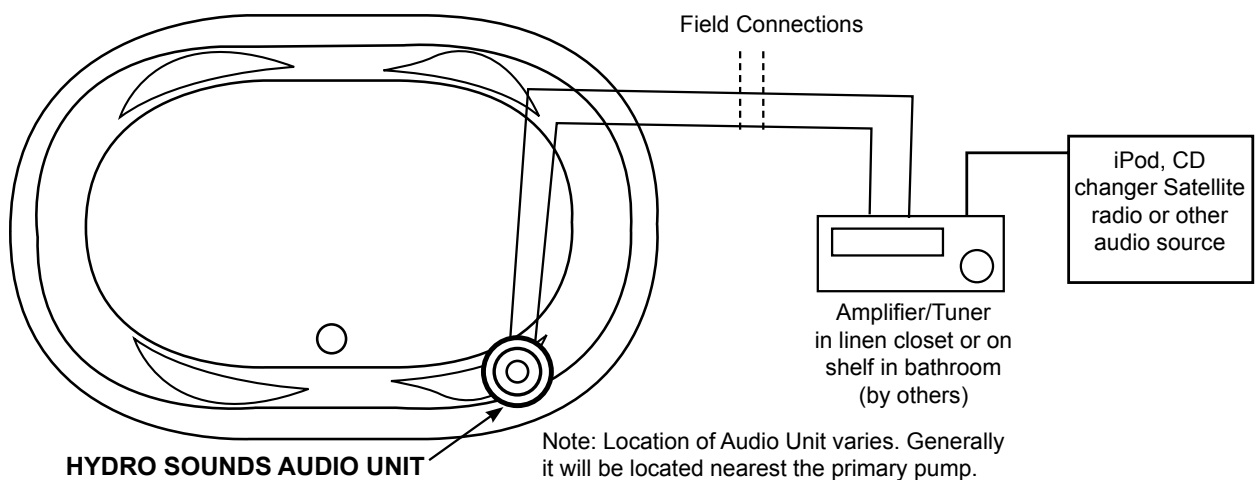

HYDRO SOUNDS INTEGRATED IN ZONED HOME AUDIO SYSTEM

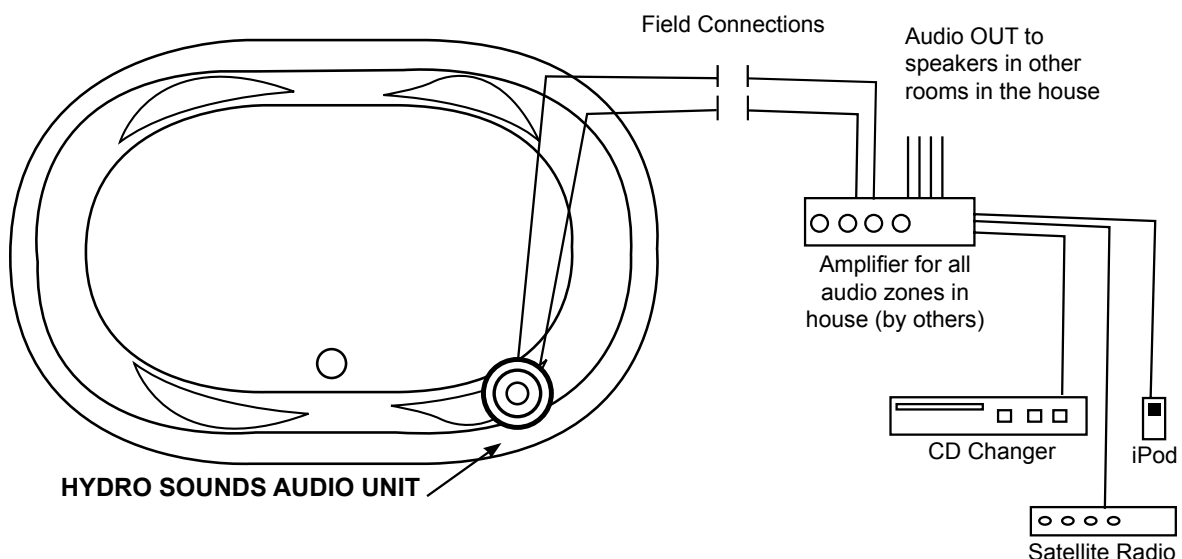

OPERATING INSTRUCTIONS

For All Whirlpool Bath Systems

This page contains general information needed for the proper operation of your Whirlpool Bath. For more specific operating instructions, refer to the appropriate section of this Manual.

WARNING: BEFORE OPERATING REFER TO THE INSTRUCTIONS PERTAINING TO THE RISK OF FIRE ELECTRICAL SHOCK OR INJURY TO PERSONS ON PAGE 1 OF THIS MANUAL.

CAUTION: DO NOT OPERATE THIS UNIT WITHOUT THE GUARD COVER OVER THE SUCTION FITTING.

TO OPERATE

1. Filling and Draining – Close the drain, fill tub with water at the desired temperature. The maximum recommended bathing temperature is 104° F (40° C). The water must be at least 3” above the highest jet before activating the pump. Fill the tub to use and drain when finished. Each bather should start their bath with fresh water.

NEVER ATTEMPT TO RUN THE PUMP MOTOR WITHOUT ENOUGH WATER TO COVER ALL THE JETS. WATER LEVEL SHOULD BE 3" ABOVE THE HIGHEST JET.

2. WHIRLPOOL JETS – The direction of most of the jets is adjustable. Point the jets down before turning on the system. All models also have flow adjustable jets.

3. SUCTION – Never operate the whirlpool system without the guard cover over the suction fitting. Keep hair, towels, and clothing away from the suction fitting whenever the Hydro Massage pump is on. The suction guard cover is a safety device designed to eliminate the potential of hair and body entrapment.

4. Flush the whirlpool system periodically. See User Maintenance Instructions on pages 27 & 28.

WARNING...Refer all plumbing or electrical repair to a qualified service technician. DO NOT ATTEMPT TO RESOLVE THE PROBLEM. Attempts to repair plumbing or electrical equipment by a non-qualified service technician can result in danger of electrical shock or damage to the unit. Call your dealer for the name of the qualified service technician near you.

The user should do no servicing of this product. There are no user serviceable parts. All controls and air switches are located on the deck of the tub. These are the only controls that should be used by the consumer. Do not change or alter any of these controls under any circumstances. Motors are self-lubricating and no lubrication is required. This unit can only be serviced by a qualified service representative.

WARNING...Prolonged immersion in hot water may induce extremely high body temperature (hyperthermia). Hyperthermia occurs when the internal temperature of the body reaches a level several degrees above the normal body temperature of 98.6° F. The symptoms of hyperthermia include an increase in the internal temperature of the body, dizziness, lethargy, drowsiness and fainting. The effects of Hyperthermia include:

1. Failure to perceive heat
2. Failure to recognize the need to exit the tub
3. Unawareness of impending hazard
4. Fetal damage in pregnant women
5. Physical inability to exit the tub, and
6. Unconsciousness resulting in the danger of drowning

WARNING: The use of alcohol, drugs, or medication can greatly increase the risk of fatal hyperthermia.

OPERATING INSTRUCTIONS

For Hydro Bronze, Silver and Gold Series

NOTE: Do not start pump until all jets are submerged water level should be 3" above highest jet.

ON/OFF AIR BUTTON CONTROL: Press the button once and the pump will turn on. Press the button again and the pump will turn off.



THREE SPEED PUMP CONTROL (Gold Series):

To operate the 3 speed control, turn the dial to change the speed. H(High) to M(Medium) to L (Low)



MOOD LIGHT ON/OFF AIR BUTTON (Gold Series): Press the button once and light turns on. Press the button again and the light turns off.



BULB REPLACEMENT:

See page 26 for bulb replacement and lens instructions.

MICROFLOW, ULTRA FLOW, AND SOUL SOOTHER JET PRESSURE ADJUSTMENT:

Turning the jet face clockwise will reduce the pressure up to 95% off.

Outer Ring-Turn On & OFF

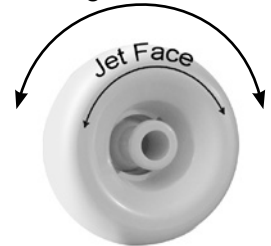

HYDROCLEAN SANITATION SYSTEM: (Silver & Gold Series) See page 25 for operating instructions.

INLINE MAINTENANCE HEATER CONTROL: (Gold Series) See page 25 for operating instructions.

OPERATING INSTRUCTIONS

For Hydro Platinum Series

NOTE: Do not start pump until all jets are submerged water level should be 3" above highest jet.

DUAL ON/OFF AIR BUTTON CONTROL:

Operates each pump/jet action independently. Press the button once and the pump will turn on. Press the button again and the pump will turn off.



THREE SPEED PUMP CONTROL:

To operate the 3 speed control, turn the dial to change the speed. H(High) to M(Medium) to L (Low)

NECK MASSAGE PILLOW:

Turning the dial counter-clockwise will open the Neck Massage Pillow pressure to 100%. Turning the dial clock wise will reduce the pressure down to 5%.

NOTE: Before operating the Neck Massage Pillow, make sure the Lycra pillow cover is covering the grey pillow and the pillow is seated securely in the grommets.

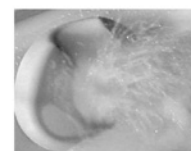

Neck Massage Pillow with Cover

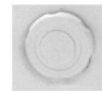

Neck Massage pillow valve dial

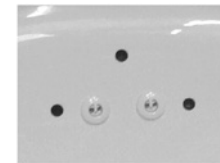

Neck Massage Jets & Grommets without pillow & pillow cover

CHROMATHERAPY ON/OFF AIR BUTTON (Gold Series):

Press the button once and light turns on. Press the button again and the light turns off.

BULB REPLACEMENT:

See page 26 for bulb replacement and lens instructions.



MICROFLOW, ULTRA FLOW, AND SOUL SOOTHER JET PRESSURE ADJUSTMENT:

Turning the **jet face** clockwise will reduce the pressure up to 95% off.

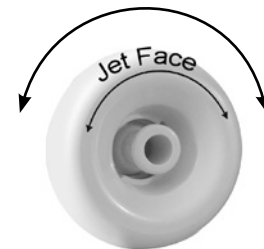

Outer Ring-Turn On & OFF

HYDROCLEAN SANITATION SYSTEM: See page 25 for operating instructions.

INLINE MAINTENANCE HEATER CONTROL: See page 25 for operating instructions.

OPERATING INSTRUCTIONS

For Silver Air Systems

ON/OFF AIR BUTTON: Your bath is equipped with a pneumatic On/Off Button that allows the user to turn the blower On and Off and controls the blower's intensity. A timer will automatically turn off the blower after 20 Minutes if it is not stopped manually.



To start a bath with a pneumatic On/Off Button, simply depress the On/ Off Button and the blower will turn on.

BLOWER SPEED: Once the blower is on, depressing the button again will decrease the air output to medium speed, depressing the button again will decrease the air output to low speed, depressing the button again will start the Wave mode and a final depression of the button will turn off the blower.

AUTOMATIC PURGE CYCLE: Fifteen minutes after the blower is stopped and the bath is drained the blower will automatically start for two (2) minutes to purge and dry the air system channels or plumbing.

OPERATING INSTRUCTIONS

For Gold and Platinum Air Systems

- #1. 1st press: The blower starts at maximum speed, LED: ON
2nd press: The blower stops, LED: ON until the purge cycle stops. Approximately 20 minutes.
- #2. 1st press: Speed goes up, LED ON when pressing release pressure at the desired speed
- #3. 1st press: Speed goes down, LED: ON when pressing release pressure at the desired speed
- #4. 1st press: Slow pulsation cycle ON, LED: ON
2nd press: Quick pulsation cycle OFF, LED: flashes
3rd press: Pulsation cycle OFF, LED: OFF

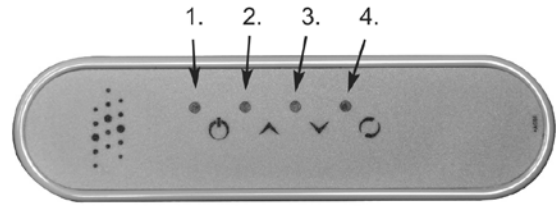

Your blower is equipped with an integrated air heating element, built in electronic control, variable speeds, pulsation cycle, a 20 minute timer and an automatic drying cycle, which will activate approximately 20 minutes after the blower has been turned off.

CHROMATHERAPY LIGHT ON/OFF AIR BUTTON:

(Platinum Series) Press the button once and light turns on. Press the button again and the light turns off. See page 26 for color sequence.

MOOD LIGHT ON/OFF AIR BUTTON: (Gold Series) Press the button once and light turns on. Press the button again and the light turns off.

BULB REPLACEMENT: See page 26 for bulb replacement and lens instructions.



OPERATING INSTRUCTIONS

For Silver Combination Systems

NOTE: Do not start pump until all jets are submerged; water level should be 3" above highest jet.

ON/OFF AIR BUTTON PUMP CONTROL: Press the button once and the pump will turn on. Press the button again and the pump will turn off.

ON/OFF AIR BUTTON BLOWER CONTROL: Your bath is equipped with a pneumatic On/Off Button that allows the user to turn the blower On and Off and controls the blower's intensity. A timer will automatically turn off the blower after 20 Minutes if it is not stopped manually.

To start a bath with a pneumatic On/Off Button, simply depress the On/ Off Button and the blower will turn on.

Blower Speed: Once the blower is on, depressing the button again will decrease the air output to medium speed, depressing the button again will decrease the air output to low speed, depressing the button again will start the Wave mode and a final depression of the button will turn off the blower.

Automatic Purge Cycle: Fifteen minutes after the blower is stopped and the bath is drained the blower will automatically start for two (2) minutes to purge and dry the air system channels or plumbing.

MICROFLOW AND ULTRA FLOW JET PRESSURE

ADJUSTMENT: Turning the jet face clockwise will reduce the pressure up to 95% off.

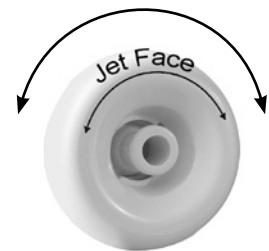

Outer Ring-Turn On & OFF

MOOD LIGHT ON/OFF AIR BUTTON: Press the button once and light turns on. Press the button again and the light turns off.

BULB REPLACEMENT: See page 26 for bulb replacement and lens instructions.

HYDROCLEAN SANITATION SYSTEM: See page 25 for operating instructions.

OPERATING INSTRUCTIONS

For Gold Combination Systems

NOTE: Do not start pump until all jets are submerged; water level should be 3" above highest jet.

ON/OFF AIR BUTTON PUMP CONTROL: Press the button once and the pump will turn on. Press the button again and the pump will turn off.

THREE SPEED PUMP CONTROL: To operate the 3 speed control, turn the dial to change the speed. H(High) to M(Medium) to L (Low)

ELECTRONIC BLOWER CONTROL:

- #1. 1st press: The blower starts at maximum speed, LED: ON
2nd press: The blower stops, LED: ON until the purge cycle stops. Approximately 20 minutes.
- #2. 1st press: Speed goes up, LED ON when pressing release pressure at the desired speed
- #3. 1st press: Speed goes down, LED: ON when pressing release pressure at the desired speed
- #4. 1st press: Slow pulsation cycle ON, LED: ON
2nd press: Quick pulsation cycle OFF, LED: flashes
3rd press: Pulsation cycle OFF, LED: OFF

MICROFLOW, ULTRA FLOW AND SOLE SOOTHER JET PRESSURE ADJUSTMENT: Turning the jet face clockwise will reduce the pressure up to 95% off.

CHROMATHERAPY LIGHT ON/OFF AIR BUTTON: Press the button once and light turns on. Press the button again and the light turns off. See page 26 for color sequence.

BULB REPLACEMENT: See page 26 for bulb replacement and lens instructions.

HYDROCLEAN SANITATION SYSTEM: See page 25 for operating instructions.

INLINE MAINTENANCE HEATER CONTROL: See page 25 for operating instructions.

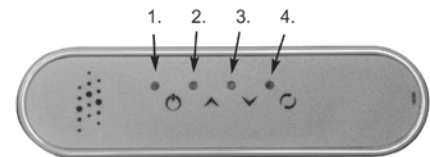

Your blower is equipped with an integrated air heating element, built in electronic control, variable speeds, pulsation cycle, a 20 minute timer and an automatic drying cycle, which will activate approximately 20 minutes after the blower has been turned off.

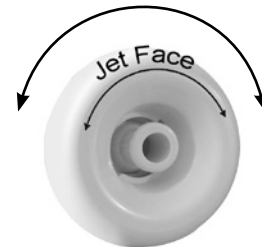

Outer Ring-Turn On & OFF



OPERATING INSTRUCTIONS

For Platinum Combination Series

NOTE: Do not start pump until all jets are submerged water level should be 3" above highest jet.

DUAL ON/OFF AIR BUTTON CONTROL Operates each pump/jet action independently. Press the button once and the pump will turn on. Press the button again and the pump will turn off.



THREE SPEED PUMP CONTROL:

To operate the 3 speed control, turn the dial to change the speed. H(High) to M(Medium) to L (Low)



NECK MASSAGE PILLOW

Turning the dial counter-clockwise will open the Neck Massage Pillow pressure to 100%. Turning the dial clock wise will reduce the pressure down to 5%.

NOTE: Before operating the Neck Massage Pillow, make sure the Lycra pillow cover is covering the grey pillow and the pillow is seated securely in the grommets.



Neck Massage Jets & Grommets without pillow & pillow cover

ELECTRONIC BLOWER CONTROL:

#1. 1st press: The blower starts at maximum speed, LED: ON
2nd press: The blower stops, LED: ON until the purge cycle stops. Approximately 20 minutes.

#2. 1st press: Speed goes up, LED ON when pressing release pressure at the desired speed

#3. 1st press: Speed goes down, LED: ON when pressing release pressure at the desired speed

#4. 1st press: Slow pulsation cycle ON, LED: ON
2nd press: Quick pulsation cycle OFF, LED: flashes
3rd press: Pulsation cycle OFF, LED: OFF

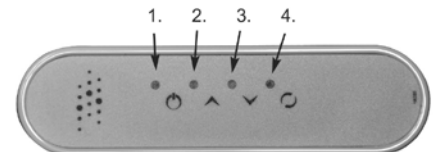

Your blower is equipped with an integrated air heating element, built in electronic control, variable speeds, pulsation cycle, a 20 minute timer and an automatic drying cycle, which will activate approximately 20 minutes after the blower has been turned off.

OPERATING INSTRUCTIONS

For Platinum Combination Series (continued)

NOTE: Do not start pump until all jets are submerged water level should be 3" above highest jet.

CHROMATHERAPY ON/OFF AIR BUTTON (Gold Series):

Press the button once and light turns on. Press the button again and the light turns off.



BULB REPLACEMENT:

See page 26 for bulb replacement and lens instructions.

MICROFLOW, ULTRA FLOW, AND SOUL SOOTHER JET PRESSURE ADJUSTMENT:

Turning the **jet face** clockwise will reduce the pressure up to 95% off.

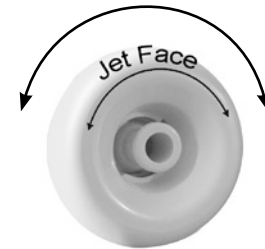

Outer Ring-Turn On & OFF

HYDROCLEAN SANITATION SYSTEM: See page 25 for operating instructions.

INLINE MAINTENANCE HEATER CONTROL: See page 25 for operating instructions.

HYDRO SCENTS AROMATHERAPY

The entire bag of beads should be put in the canister. Never put beads in separately in the canister. Always leave the beads in the bag.

The beads do not breakdown or dissolve. The fragrance just dissipates over time. Once the fragrance is gone, remove the bag of beads and replace.



HYDROCLEAN SANITATION SYSTEM

1. This unit meets the requirements of NSF Protocol P308 ozone sanitation systems for jetted bathtubs and pedicure foot-baths.
2. The Hydroclean will operate automatically whenever the pump is running. You will notice a slight sweet smell and bubbles will be coming out of the dedicated Hydroclean jet on the side wall of the tub about 1 1/2 " in diameter.
3. No maintenance or cleaning of the unit is required. The life of the unit is approximately 9000 hrs of use.

INLINE MAINTENANCE HEATER

The whirlpool heater is totally self-contained to insure trouble free operation. Once the whirlpool heater is plugged in, operation is automatic. The heater will maintain the temperature of the water in the bath tub. As with all electrical devices, certain safety precautions should be taken during use. Please read Safety Instructions on Page 1 of this Manual.

Features of the Inline Heater:

Hi-Limit: Some whirlpool heaters include an exclusive "Smart Hi-Limit". This Hi-limit will not "false trip" from hot tap water. It will only turn the heater off if the thermostat fails. To reset, simply press the red button located on the heater. If the Hi-limit trips frequently, call the factory.

Safety features: In addition to the thermostat and Hi-limit, the whirlpool heater is equipped with a built in pressure switch. This switch will not allow the heater to turn on if the pump is not running.

CAUTION: Before use of the pump and heater, test the GFCI for proper operation. The pump and heater should turn off when the GFCI "TEST" button is pushed. Note: the heater will only operate if the pump is running.

WARNING... Prolonged immersion in hot water may induce extremely high body temperature (hyperthermia). Hyperthermia occurs when the internal temperature of the body reaches a level several degrees above the normal body temperature of 98.6° F. The symptoms of hyperthermia include an increase in the internal temperature of the body, dizziness, lethargy, drowsiness and fainting. Symptoms of Hyperthermia include:

1. Failure to perceive heat
2. Failure to recognize the need to exit the tub
3. Unawareness of impending hazard
4. Fetal damage in pregnant women
5. Physical inability to exit the tub, and
6. Unconsciousness resulting in the danger of drowning

WARNING: The use of alcohol, drugs, or medication can greatly increase the risk of fatal hyperthermia.

OPERATING INSTRUCTIONS

Mood Light & Chromatherapy

MOOD LIGHT: Press the on/off button once to turn on light; Press it again to turn off. Mood light comes with 1 red and 1 blue colored lens cover.

CHROMATHERAPY: Use the on/off button for the following sequence:

- | | |
|---|----------------------------------|
| 1 st press starts slow transition through all colors | 2 nd press turns off |
| 3 rd press is all colors on | 4 th press turns off |
| 5 th press is BLUE and GREEN | 6 th press turns off |
| 7 th press is BLUE and RED | 8 th press turns off |
| 9 th press is BLUE | 10 th press turns off |
| 11 th press is RED and GREEN | 12 th press turns off |
| 13 th press is GREEN | 14 th press turns off |
| 15 th press is RED | 16 th press turns off |
| 17 th press is slow flicker of above sequence | 18 th press turns off |
| 19 th press is fast flicker of all colors | 20 th press turns off |
| 21 st press starts cycle over. | |

If light is off for more than (approximately) 3 seconds, the sequence starts over.

RE-LAMPING INSTRUCTIONS

1. Disconnect the power to the bathtub.
2. Drain the bathtub.
3. To remove lens, position the wrench over the light in such a way that both the wall fitting and the lens splines engage.
4. While firmly holding the outer ring of the wrench and free of rotation, turn the center part of the tool counter-clockwise to unscrew the lens.
5. Replace Mood Light bulb with type 912 bulb only. (Contact factory to purchase replacement Chromatherapy bulb)
6. Do not twist bulb into socket! Use gentle pressure and push bulb into place.
7. Inspect o-ring to make sure that it is clean and free of damage and is properly positioned in the o-ring groove before replacing lens.
Note: If a replacement o-ring is necessary or lens does not seal properly, do not fill bathtub. Contact Factory immediately.
8. To replace lens, gently screw the lens into the wall fitting finger tight.
9. Position the wrench over the light so that both the wall fitting and the lens splines engage.
10. While firmly holding the outer ring of the wrench and free of rotation, turn the center part of the tool clockwise until rotation comes to a stop. **Do not over tighten!**

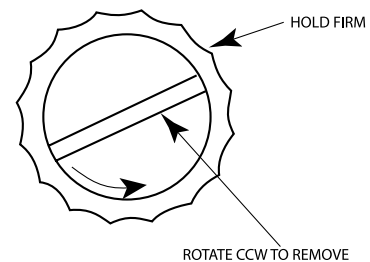

Light Lens, bulb and 'O' ring. Chromatherapy bulb shown

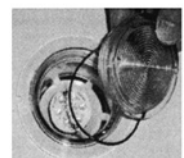

USER MAINTENANCE INSTRUCTIONS

INITIAL CLEANING

Before tub is used, the whirlpool system should be cleaned out and disinfected. Remove all debris and clean tub before putting the whirlpool into service. **DO NOT USE ABRASIVE CLEANERS ON THE ACRYLIC SURFACE.** Use a non-abrasive detergent that is approved for acrylic such as Mr. Clean, Fantastic, Lysol Tub & Tile Cleaner and rinse well after cleaning.

- Fill the tub with HOT water to a level 3" above the highest jet
- Add 4 ounces of **Hydro Cleanse™** whirlpool cleaner
- Operate whirlpool for 5 minutes; allow water to set in tub for 30 minutes. Operate whirlpool for another 2 minutes and drain tub. There is no need for rinsing.

REGULAR SYSTEM CLEANING

Hydro Cleanse™ should be used after each use or every 3 weeks when unit is not in use. If combined with the Hydro Clean™ Sanitation unit, the need for Hydro Cleanse™ and routine cleaning will be greatly reduced.

- Fill the tub with hot water to a level 3" above the highest jet. You can also save water by doing your regular system cleaning with the water left in the tub after your bath.
- Add 2 ounces of **Hydro Cleanse™** whirlpool cleaner
- Operate whirlpool for 5 minutes. If whirlpool foams excessively, shut system off and restart after foam dissipates.
- Allow water to soak in whirlpool for at least 30 minutes. Operate whirlpool for another 2 minutes and drain tub. There is no need for rinsing unless excessive foam is still present. The foaming could be an indication of bubble bath or bath oils used in tub (NOT recommended).
- If you don't use the whirlpool system during your bath, we recommend that you run the whirlpool system for a short period of time before draining the tub.

Hydro Cleanse™ whirlpool cleaner is specifically made for use in whirlpool and air systems. Run the pump for a minimum of 5 minutes. We also recommend using these products to maintain a clean and sanitary whirlpool.

Eco Pure™ All natural Bath & Body Conditioner: Add two cap fulls while bathing a minimum of two times per month. **Eco Pure™ Bath & Body** provides the following health benefits:

- Re-hydrates and nourishes your body with natural vitamins and minerals.
- Moisturizes your skin and leaves it silky smooth.
- Helps eliminate Bio Residual contaminants on jets and internal plumbing system.
- Works with Hydro Therapy to reduce stress, relieve pain, detoxify and stimulate both your digestive and immune systems.
- Naturally purifies water for a healthier home bath experience.
- Reduces cleaning and maintenance of the bath surface.

USER MAINTENANCE INSTRUCTIONS

CONTINUED

SURFACE CLEANING

Use common, household NON ABRASIVE cleaners for most cleaning jobs. Rinse well and dry with clean cloth. Never use abrasives such as scouring compounds, scouring pads, steel wools or harsh chemicals. Rubbing Alcohol will remove most stubborn buildup and even some scuff marks. Do not allow your acrylic surface to come into contact with products such as acetone (nail polish remover), nail polish, dry cleaning solutions, lacquer thinners, gasoline, pine oil, etc. Remove dust with a wet sponge, and dry with a soft, dry cloth. Paint splashes with a quick wipe of mineral spirits followed by a rinse with water. Regular use of a quality automotive wax will maintain the sparkling finish of your tub. **NOTE:** Your tub will become extremely slick after wax is applied!

SURFACE SCRATCH REMOVAL

Minor scratches may be removed by polishing tub with a NON ABRASIVE car polish and then buff out. For deeper scratches we recommend contacting a bathtub repair or refinishing company.

WALK-IN BATHS

It is especially IMPORTANT to wipe down the door seal and door jamb after each use in order to maintain the integrity of the water seal. In order to keep the door seal and door jamb clean and not accumulate dirt or debris of any kind, clean seal and jamb with a mild detergent and warm water using a soft cloth. The door is to remain open and unlatched when not in use.

WHAT PRODUCTS ARE COVERED

Structures and surface finishes, pumps and blowers. All Hydro Massage Products models except Bronze (Colorado Only)

LIFETIME WARRANTY FOR WHIRLPOOL/AIRBATH/TUB SHELL, PUMP AND BLOWER

Hydro Massage Products extends to the original consumer/purchaser of the acrylic, fiberglass reinforced shell, a non-transferable lifetime warranty that the shell will retain its structural integrity and configuration and be free of water loss due to a defect in the tub shell. The warranty covers the tub shell and factory installed pump and blower against defects in material or workmanship. This warranty does not apply to all other components (attachments to acrylic, fiberglass reinforced shell, such as plumbing, fitting and other apparatus) because these are covered below under a 2 Year Warranty.

LIFETIME SURFACE WARRANTY FOR FACE OF WHIRLPOOL/AIR BATH/TUB

The interior surface is warranted against fading, blistering, cracking and delamination due to defects in the surface materials for life. The surface warranty extends to defects due to surface material mixing or molding. This surface warranty does not apply to fading, cracking, delamination or blistering due to excessive wear, sun fading or scouring due to cleaning.

2 YEAR EQUIPMENT WARRANTY FOR SUPPORT EQUIPMENT, COMPONENTS, CONTROLS & PLUMBING EQUIPMENT

All support equipment, components, controls and plumbing equipment are warranted for 2 years from date of purchase, but not more than 3 years from date of manufacture, against defects in workmanship and materials. Light bulbs, fuses, and pillows are not included in this two-year period. However, these accessories are warranted to be free from defects in materials and workmanship at the time of delivery to the original purchaser. Limited labor is covered for 2 years from purchase, but never more than 3 years from date of manufacture, for limited labor on the support equipment, controls, and plumbing.

BRONZE SERIES WARRANTY (Colorado Only)

WHAT PRODUCTS ARE COVERED

Structures and surface finishes on Whirlpools and Soaking Tubs, and their support equipment, components, attachments, controls and plumbing equipment. Different warranty periods apply to specific components.

10 YEAR STRUCTURAL WARRANTY FOR WHIRLPOOL BATHTUB SHELL

Hydro Massage Products extends to the original consumer/purchaser of the acrylic, fiberglass reinforced shell of the Bronze series whirlpool a limited warranty that the shell will retain its structural integrity and configuration and be free of water loss due to a defect in the shell for a period of 10 years from the date of purchase, but not more than 11 years from the date of manufacturer. This limited structural warranty does not apply to the attachments to the acrylic, fiberglass reinforced shell, such as plumbing, fitting and other apparatus; these pieces are covered by a 2 year warranty.

10 YEAR SURFACE WARRANTY FOR FACE OF WHIRLPOOL BATH/TUB

The interior surface/face of a Bronze Series Whirlpool is warranted against fading, blistering, cracking and delamination due to defects in the surface materials for a period of 10 years from the date of purchase, but never more than 11 years from date of manufacturer. This surface warranty extends to defects due to surface material mixing or molding. This surface warranty does not apply to fading, cracking, delamination or blistering due to excessive wear, sun fading or scouring due to cleaning.

2 YEAR EQUIPMENT WARRANTY FOR SUPPORT EQUIPMENT, COMPONENTS, CONTROLS & PLUMBING EQUIPMENT

All support equipment, components, controls and plumbing equipment on the Bronze Series Whirlpools are warranted for 2 years from date of purchase, but not more than 3 years from date of manufacturer, against defects in workmanship and materials. Pump seals, "O" rings, light bulbs, fuses and pillows are not included in this two-year period. However, these accessories are warranted to be free from defects in materials and workmanship at the time of delivery to the original purchaser. Limited labor is covered for 1 year from purchase, but never more than 2 years from date of manufacture, for limited labor on support equipment, controls, or plumbing.

LIMITED WARRANTY PERIOD AND WARRANTY REQUIREMENTS

The limited warranty period begins on the date of purchase from an authorized Hydro Massage Products dealer or twelve (12) months from date of manufacture, whichever occurs earlier.

This warranty extends to the original purchaser or original end user only and is not transferable to a subsequent owner or user.

Customer's dated sales or delivery receipt, showing the date of purchase of the product, is Customer's proof of the purchase date. Customer may be required to provide proof of purchase as a condition of receiving warranty service.

Warranty Service. In order to obtain service provided under this warranty during regular business hours, contact the dealer or distributor who sold the unit, or Hydro Massage Products directly at 1-888-409-8860.

ALL WARRANTY WORK MUST BE APPROVED BY HYDRO MESSAGE PRODUCTS BEFORE THE WORK IS PERFORMED OR THE CUSTOMER MAY BE RESPONSIBLE FOR PAYING FOR THE COST OF THE WORK. IF CUSTOMER AUTHORIZES ANY REPAIR WORK TO BE PERFORMED ON THE HYDRO MESSAGE PRODUCTS UNIT PRIOR TO OBTAINING AUTHORIZATION FOR SUCH WORK FROM HYDRO MESSAGE PRODUCTS, THEN CUSTOMER SHALL BE RESPONSIBLE FOR PAYING FOR THE COST OF SUCH WORK.

Hydro Massage Products reserves the right to use reconditioned parts that are equivalent or superior to original factory specifications. Replacement parts are warranted to be free from defects in materials and workmanship for thirty (30) days or for the remainder of the limited warranty period of the product in which they are installed, whichever is longer. Parts or products replaced under this limited warranty shall become the property of Hydro Massage Products.

Hydro Massage Products may service customer-replaceable parts by shipment of new or remanufactured replacement parts to the customer on an exchange basis.

The terms and conditions of this limited warranty constitute the complete and exclusive warranty agreement between Hydro Massage Products and Customer for the Hydro Massage Products unit and supersede any prior agreements or representations made in any Hydro Massage Products sales document or advice that may be provided by any authorized Hydromedusa dealer in connection with Customer's purchase of the product. No change to the conditions of this limited warranty is valid unless it is made in writing and signed by an authorized representative of Hydro Massage Products.

DISCLAIMER AND LIMITATION OF REMEDY:

EXCEPT AS OTHERWISE PROVIDED ABOVE, HYDRO MESSAGE PRODUCTS MAKES NO OTHER WARRANTIES, EXPRESS OR IMPLIED, INCLUDING WARRANTIES OF MERCHANTABILITY AND FITNESS FOR A PARTICULAR PURPOSE OR COMPLIANCE

WITH ANY CODE. HYDRO MESSAGE PRODUCTS EXPRESSLY DISCLAIMS ALL WARRANTIES NOT STATED IN THIS LIMITED WARRANTY.

CUSTOMER MUST READ AND FOLLOW ALL SET-UP AND USAGE INSTRUCTIONS IN THE APPLICABLE INSTALLATION, OPERATING AND/OR USER MANUAL(S). IF CUSTOMER FAILS TO DO SO, THE PRODUCT MAY NOT FUNCTION PROPERLY. The limited warranties herein shall not apply to damage caused by failure to adhere to any of the operating, installation or maintenance instructions stated in our manuals. The limited warranties herein shall not apply to any product following incorrect operating procedures, breakage or damages caused by the fault, carelessness, abuse, misuse, misapplication, improper maintenance, alteration or modification of the product, as well as any chemical or natural corrosion, fire, act of God or any other casualty.

THE CUSTOMER IS ENTIRELY RESPONSIBLE FOR THE PROPER INSTALLATION OF THE PRODUCT. Hydro Massage Products does not install or supervise the installation of its products and therefore cannot be held responsible for any default, breakage, property damage or other damage, loss or expense caused thereby or resulting therefrom, directly or indirectly.

THIS LIMITED WARRANTY DOES NOT COVER PROPERTY DAMAGE DUE TO WATER. The responsibility for water damage is solely that of the installer or Customer as we recommend a pre-install water test in the installation instructions, Owner's manual and troubleshooting guide.

The Customer/Purchaser must provide an access panel to the components of the products as described in the installation guide in order for Hydro massage products to provide for the warranty work specified herein. If such an access panel is not available, or additional travel is required to get to the job site, then any additional expense that is necessary to obtain access to the components will be the responsibility of the Customer.

This limited warranty does not apply to products or equipment that are not installed or operated in accordance with the instructions supplied by Hydro Massage Products. This limited warranty does not apply to equipment or products that are not installed in accordance with all applicable rules, regulations and legislation pertaining to such installation.

This limited warranty does not apply to products or equipment installed or operated outside the continental United States.

If any product or equipment subject to this warranty that requires warranty service is not located within 100 miles of a city with a population of at least 50,000, then Customer shall be required to pay a trip charge for the service technician in advance of any work to be performed. The amount of the trip charge shall be determined and paid at the time that the warranty service is requested.

Hydro massage products shall not be held liable for personal injuries or death to any person or for any direct, special, incidental or consequential damage, loss of time, loss of profits, inconvenience, incidental expenses, labor or material charges, or any other costs resulting from the use of the product or equipment or pertaining to the application of the present warranty, or resulting from the removal or replacement of any product or element or part covered by this warranty.

Manufacturer warrants the door seal for the life of the unit under normal use and conditions. This warranty shall not apply to any failure resulting from negligence, abuse, misuse, misapplication, alteration or modification or improper maintenance. The replacement door seal will be issued to the end user and it will be the responsibility of the end user to determine the means of installation. Manufacturer will not be liable for any incidental expenses or material charges in connection with removal or replacement of the door seal.

This Limited Warranty does not cover damages or defects caused by or which are a result of shipping damage.

Hydro Massage Products reserves the right to discontinue and/or change models, colors and specifications in design together with replacement parts without notice and without incurring any obligations.

All waste and overflows, faucets, jet trim, pillows and pump seals are warranted to be free from defects at time of delivery.

This limited warranty does not include the cost of shipping the Hydro Massage Products unit or any of its components for warranty work. The cost of any such shipping charges shall be the responsibility of the Customer.

IF THE PRODUCT FAILS TO WORK AS WARRANTED ABOVE, CUSTOMER'S SOLE AND EXCLUSIVE REMEDY SHALL BE REPAIR OR REPLACEMENT. IN NO EVENT WILL HYDRO MESSAGE PRODUCTS, ITS AFFILIATES OR SUPPLIERS BE LIABLE TO THE CUSTOMER OR ANY THIRD PARTY FOR ANY DAMAGES IN EXCESS OF THE PURCHASE PRICE OF THE PRODUCT. THIS LIMITATION APPLIES TO DAMAGES OF ANY KIND WHATSOEVER, INCLUDING ANY DIRECT OR INDIRECT DAMAGES, PROPERTY DAMAGES, LOST PROFITS, LOST SAVINGS OR SPECIAL, INCIDENTAL, CONSEQUENTIAL OR EXEMPLARY DAMAGES, WHETHER FOR BREACH OF CONTRACT, WARRANTY, TORT OR OTHERWISE, OR WHETHER ARISING OUT OF THE USE OF OR INABILITY TO USE SUCH PRODUCT, EVEN IF HYDRO MESSAGE PRODUCTS HAS BEEN ADVISED OF THE POSSIBILITY OF SUCH DAMAGES OR OF ANY CLAIM BY ANY OTHER PARTY.

This limited warranty gives the Customer specific legal rights and the Customer may have other rights, which vary from one state and/or province to another.

WHAT IS NOT COVERED BY THIS LIMITED WARRANTY?

- Service made necessary by modification of the product or by accident, misuse, abuse, neglect, improper installation, or improper maintenance. Replacement of missing parts, the provision of retrofits, or preventive maintenance.
- Installation or removal of accessory retrofits or peripheral equipment of which the Hydro Massage Products unit may be a part.
- Service made necessary by any external cause, including fire, theft, acts of God, alteration, power failures, surges or shortages, lightning, or repairs by persons other than those authorized by Hydro Massage Products.
- Damage caused by the use of the Hydro Massage Products unit outside the usage parameters set forth in the Hydro Massage Products owner or users manual.
- Repair or replacement of plastics, or appearance parts such as interior or exterior finishes or trim.

COMMERCIAL LIMITATIONS. The limited warranty period for products installed for commercial applications or used in commercial applications or used in commercial ventures is the same as set forth above, except that the limited warranty period is reduced and limited to one (1) year from the initial date of purchase from an authorized dealer by the Customer for all parts and labor. Hydro Massage Products is not responsible to the Customer for the loss of use or loss of profits under any circumstances. If the product is used as a display model, the unit warranty is for one year and begins from the date of manufacture.

TROUBLESHOOTING GUIDE

PUMP MOTOR DOES NOT START

- 1. Pump not plugged in**
Verify that all tub components are plugged in.
- 2. GFCI or circuit breaker in off position**
Check circuit breaker panel or GFCI outlet where pump is plugged in to verify power source.
- 3. Tubing disconnected from button or switch on motor**
Check to make sure it is connected and operational
- 4. Push button broken**
Contact your dealer or fill out Service Order Request form. ***
- 5. Thermal overload on motor tripped**
Allow motor to cool down.
- 6. Disconnected or defective wiring**
Call electrician.
- 7. Low voltage**
Call electrician.

MOTOR OVERHEATS

- 1. Low voltage**
Call electrician
- 2. Inadequate ventilation**
Create a large dead air space for proper air circulation.
- 3. Wiring too small**
Call electrician.

LOW JET/PUMP PRESSURE

- 1. 3 speed control knob in low position**
Adjust knob to desired setting.
- 2. Jets are in off position or not fully open**
Turn jet face counter-clockwise to open.
- 3. Suction Guard partially blocked**
Remove and/or clean blockage from suction.
- 4. Impeller clogged**
Contact service technician.

NOISY PUMP AND MOTOR

- 1. Worn motor bearings**
Contact service technician.
- 2. Suction pipe partially clogged**
Contact service technician.
- 3. Pump not supported properly**
Contact service technician.
- 4. Pump or tube touching framing**
Contact service technician.

LEAK AT PUMP

- 1. Shaft seal leaking**
Contact service technician.
- 2. Leak at pump or heater unions**
Verify O-ring is in proper location and tighten the unions.

MOOD LIGHT/CHROMATHERAPY LIGHT DOESN'T LIGHT

- 1. Light switch box not plugged in**
Verify that all tub components are plugged in.
- 2. GFCI or circuit breaker in off position**
Check circuit breaker panel or GFCI outlet where pump is plugged in to verify power source.
- 3. Tubing disconnected from push button or switch box**
Check to make sure tubing is connected and operational.
- 4. Push button broken**
Contact your dealer or fill out Service Order Request Form.***
- 5. Burned-out bulb**
Replace bulb. Instructions on page 28

GFCI TRIPPING

- 1. Two components are on one circuit**
Call electrician.
- 2. Incorrectly wired**
Call electrician.

AIR BLOWER STARTS ON ITS OWN

- 1. The air system is designed to turn on automatically 20 minutes after use**
- 2. A power outage may cause blower to purge**

BLOWER RUNS BUT AIR IS NOT COMING OUT OF JETS

- 1. Manifold hose is disconnected**
Reconnect hose with pipe clamps.

BLOWER RUNS, NOT ALL JETS ARE WORKING

- 1. Jets are clogged with hard water or other debris**
Fill the unit up with water, add **Hydro Cleanse™** and let soak for 30 minutes.

BLOWER OVERHEATS AND SHUTS OFF

- 1. Not enough ventilation around tub**
Clear area under tub so there is a dead air space for proper ventilation.
- 2. Low voltage or improper wiring**
Call electrician

TROUBLESHOOTING GUIDE

Continued

*** For any questions or technical support, contact us with your model and serial numbers located on label by motor at 303-341-1845. For parts or Warranty Claims, contact your Dealer or fill out our Service Request Form which can be found on our website at www.hydroassageproducts.com, then click "Help & Resources" then "Downloads".

WALK-IN BATHS DOOR SEAL LEAKING

If a small leak has been detected around the door, check closely for any accumulation of dirt or debris. Any small collection of either on the door seal or where the seal comes in contact with the door jamb could result in a minor leak through the door seal.

1. Before filling tub with water, be sure to wipe down the door seal using a damp soft cloth, as well as the surface on the door jamb that will come in contact with the seal.
2. Once the above surfaces have been wiped clean, be sure that when closing the door, the latch is completely locked forward.

NOTE: When draining the water from the tub, be sure that the door latch is in the locked position (forward). If the latch is not secure when draining the tub, as the water level lowers, the pressure on the door will be reduced, thus increasing the possibility of a leak around the door.

HYDRO MASSAGE PRODUCTS

Product Registration Information and Warranty Confirmation

ATTENTION: To ensure that your warranty is registered and confirmed with the manufacturer, please take a few moments to complete, sign and return the Product Registration Card provided below within 30 days of the date of purchase.

WARRANTY CONFIRMATION: By returning this Product Registration Card, we can confirm the date of purchase for your new product. This confirmation will allow Hydro Massage Products to process any warranty claims.

PURCHASE REGISTRATION: The information provided on the Product Registration Card such as model number, serial number and other important information will be kept on file with Hydro Massage Products as your official Purchase Registration. In the event of fire, flood, or theft your product Registration card can serve as your Proof of Purchase for insurance purposes.

Your warranty will not be recognized unless this card is fully completed and returned to Hydro Massage Products within 30-day time allocation.

Hydro Massage Products

Product Registration Card

Name: _____ Dealer Name: _____

Address: _____ Tub Model: _____ Color: _____

City: _____ State: _____ Zip: _____

Date Purchased: ___ / ___ / ___ Serial # _____ :

Phone: { } _____

I have read the Owner's Manual carefully and thoroughly understand and agree that any installation, operation or maintenance of the whirlpool must be done strictly in accordance with instructions and guidelines contained in the Hydro Massage Products Owner's Manual and the installation and service manuals provided.

Signature: _____