

CLICK ANYWHERE on THIS PAGE to RETURN TO
HELLENBRAND WATER SOFTENERS at
InspectApedia.com

Hellenbrand[®]

H151 HE - High Efficiency Water Softening System



Owner's Manual

800683 Rev A
10/20/17-LBRY
©2016-2017

Manufactured by:
HELLENBRAND, INC.
404 Moravian Valley Road
Waunakee, Wisconsin 53597-2509
Web: www.hellenbrand.com • Email: info@hellenbrand.com

This owner's manual is designed to assist owners and installers with the operation, maintenance and installation of your new water softener. It is our sincere hope that this manual is clear, concise and helpful to both owner and installer. We have included detailed instructions on general operating conditions, pre-installation and installation instructions, start-up, and timer and meter programming. We have included a troubleshooting guide, service instructions and parts diagrams to assist you.

In the event that you need professional assistance for servicing your water softener, please contact the dealer who installed this system.

TABLE OF CONTENTS

Job Specification Sheet.....	3
Soft Water Basics.....	4
Pre-Installation Check List.....	5
Installation Instructions.....	6-7
Programming.....	8-19
Water Softener Disinfection.....	20
Water Softener Draining Procedure.....	20
Trouble Shooting.....	21-23
Conditioner and Salt Assemblies.....	24
Meter Specs.....	25
Parts Diagrams.....	26-29
Flow Diagrams.....	30-32
Programing Options.....	33
General Specifications.....	33
Service Instructions.....	34-35
Injector Flow Rate Graphs.....	36-37
Specifications.....	38
Warranty.....	40

Dealer Name _____ Phone _____

Address _____

JOB SPECIFICATION SHEET

MODEL NO. _____

*WATER TEST AT TIME OF INSTALLATION

_____ Hardness CaCO₃ (gpg) _____ Other _____
_____ Iron (ppm) _____ Other _____
_____ pH _____ Other _____

OPTIONAL RELAY SETTINGS

_____ Off _____ Reclamation mode enabled
_____ No Hard By-pass enabled
_____ Alternator system enabled
_____ Demand Recall

Relay 1

_____ **On Time**
_____ Start Time, Minutes into Regeneration
_____ Run Time
_____ **On Gallons**
Pulse per _____ Gallons
_____ Length Relay Closed
_____ **On Regen Gallons**
(Relay activated on flow through meter during regeneration and in service)
Pulse per _____ Gallons
_____ Time Relay Closed
_____ **On Service Alarm**
_____ Gallons
_____ Time
_____ **On Lockout**

Relay 2

_____ **On Time**
_____ Start Time, Minutes into Regeneration
_____ Run Time
_____ **On Gallons**
Pulse per _____ Gallons
_____ Length Relay Closed
_____ **On Regen Gallons**
(Relay activated on flow through meter during regeneration and in service)
Pulse per _____ Gallons
_____ Time Relay Closed
_____ **On Service Alarm**
_____ Gallons
_____ Time
_____ **Error**
_____ **On Lockout**

*SIZING INFORMATION

All Water is Softened Except:

_____ Hosebibs _____ Kitchen Cold _____ Toilets _____ All Cold
_____ Other _____

*INSTALLATION DATE _____

*SERIAL NUMBER _____

NOTES _____

SOFT WATER BASICS

Hardness

Excess amounts of calcium and magnesium in water produce hardness. A water softener removes the majority of calcium and magnesium to produce softened water.

Hardness is measured in terms of grains. (This grain weight is derived from the average weight of a dry grain of wheat.) When your water is tested, the grain hardness is calculated and expressed as grains per gallon (gpg). This calculation determines what type and size of water softener will most efficiently soften the water.

A water softener contains an ion exchange media (sometimes called resin) which removes the hardness from water as it flows through the softener tank. Eventually so much hardness collects on the exchange media that the softener can no longer soften water. At this point it is considered "exhausted". Regeneration is now necessary.

Regeneration

To regenerate the exchange media, it must be rinsed with a brine (salt) solution. This removes the hardness from the exchange media and replaces it with sodium. The exchange media is then ready to remove hardness from water. The hardness minerals and excess brine solution are rinsed down the drain.

During the regeneration cycle the softener is also backwashed. This reversing of the normal flow of water serves to remove sediment which may have accumulated during the softening process due to the filtering action of the exchange media. Backwashing also loosens and fluffs up the bed of exchange media to insure that during regeneration the brine solution will come into contact with all the media.

Maintenance of Your Softener

Salt: Salt to a softener is what gasoline is to a car. Not only must a softener have salt, but it should be the proper type to insure efficient recharging of the unit. Ask your dealer what type of salt may best suit your needs. Always have an adequate supply of salt on hand. Check the salt level of your brine tank every couple of weeks initially to determine how much salt you use - this will depend on how much water you use. Fill the tank approximately three-fourths full, with a minimum of 12" of salt. **DO NOT USE** block salt when the H-151 control is programmed with a brine tank prefill. Block salt does not dissolve quick enough to provide a good regeneration.

Cleaning Brine Tank: Salt tank may require periodic cleaning. Inspect the brine tank at least once a year for buildup of insoluble materials. It is recommended to periodically clean the brine tank no matter what kind of salt you are using. See page 20, Miscellaneous #2 for details on cleaning.

REMEMBER: Salt is the fuel to run your water softener. Buy the **best clean salt available**.

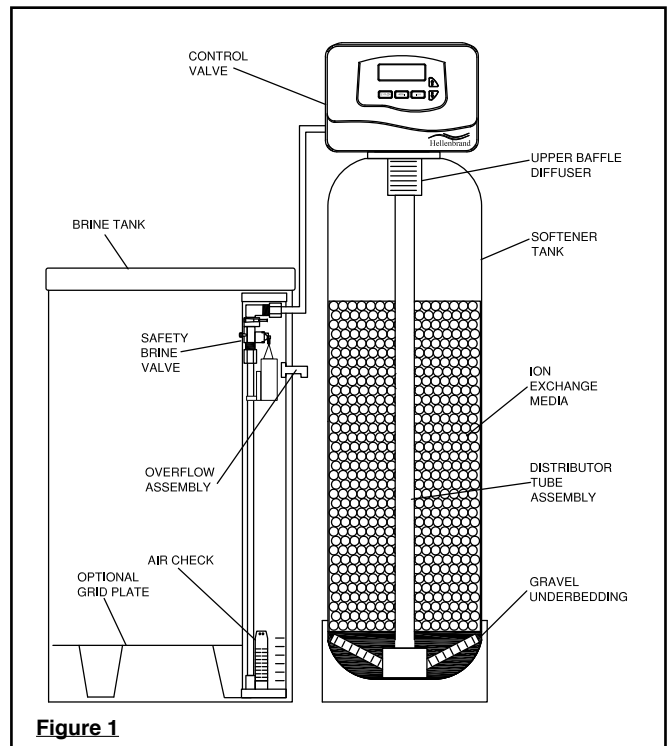

Figure 1

Units larger than 150K contain air check as standard brine tank assembly.

OPERATING CONDITIONS

Your water conditioner has been designed to adequately handle up to 40 grains per gallon of hardness as well as up to 0.5 ppm of ferrous bicarbonate iron. This is iron that is dissolved in water and not visible to the eye in a freshly drawn sample. After standing in contact with air, the ferrous iron will become oxidized to the ferric state and start to precipitate as a reddish brown floc. It can be seen and may cause discolored water. In order for your softener to remove the iron, air (oxygen) must be kept from coming in contact with water until it has been passed through the

water conditioner. In some cases, additional equipment may be required to treat water supplies having special characteristics, such as: ferric hydrozide iron, iron bacteria, low pH, taste and odors, etc. If any questions should exist, contact your dealer.

This water softener is not intended to be used for treating water that is microbiologically unsafe or of unknown quality without adequate disinfection before or after treatment.

PRE-INSTALLATION CHECK LIST

(All electrical & plumbing should be done in accordance to all local codes)

Water Pressure: A minimum of 25 pounds of water pressure (psi) is required for regeneration. Maximum 125 psi.

Water Quality: On rural water supplies there is often a problem with sand or sediment in the water. (This problem occasionally occurs in public water supplies.) Sand and sediment may plug the water softener, restricting the flow through the resin bed. This problem often requires rebedding of the mineral tank.

Note: Well and/or pump problems affecting the operation of the softener are repairs that are not covered under warranty. To prevent unnecessary, and expensive repairs not covered under warranty, the installation of an in-line filter system ahead of the softener is recommended.

Electrical: A continuous 110 volt, 60 cycle current supply is required. Make certain the current supply is uninterrupted and cannot be turned off with another switch. All electrical connections must be connected per local codes. **Surge protection is recommended with all electric controls.**

Existing Plumbing: Condition of existing plumbing must be

free from lime and iron build-up. Piping that is built-up heavily with lime and/or iron must be replaced. If piping is blocked with iron, additional equipment must be installed ahead of the water conditioner to correct the problem.

Drain Line: The conditioner should be located close to a drain. Avoid overhead drain lines if possible to prevent back pressure on the brine injector. Overhead drains are not to exceed 8 feet above the floor and no more than 20 feet in length. The pipe size for the drain line should be a minimum of 3/4". Backwash flow rates in excess of 7 gpm or length in excess of 20' require 1" drain line.

Bypass Valves: Always provide for the installation of a bypass valve.

Softening: It is recommended that the conditioner be installed to soften both the hot and cold water supply. A separate hard water faucet may be plumbed for drinking purposes if desired.

Caution: Water temperature is not to exceed 110°F; the conditioner cannot be subject to freezing conditions, or to a vacuum due to loss of pressure (such as a water main break).

BYPASS VALVE OPERATION

NORMAL OPERATION

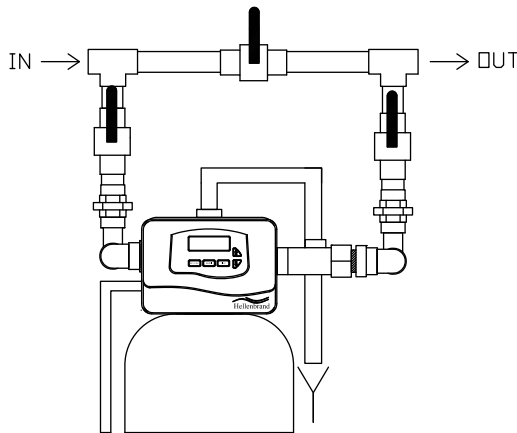

BYPASS OPERATION

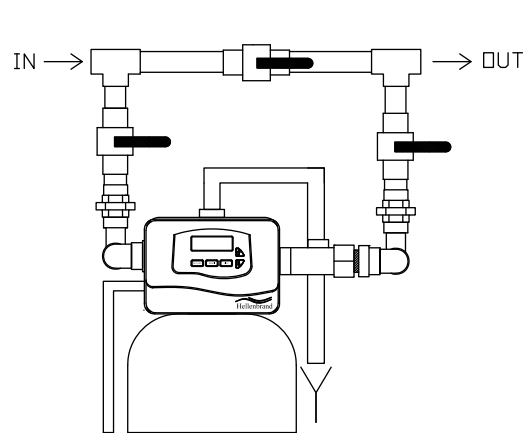

DIAGNOSTIC MODE

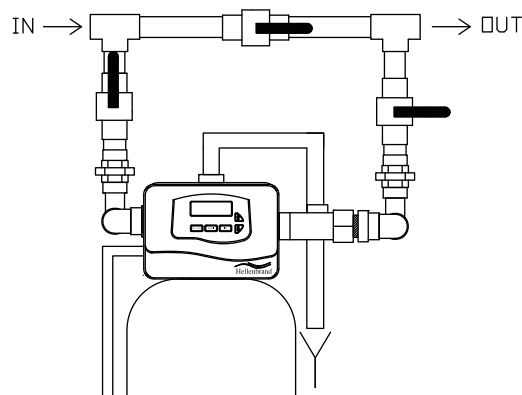

INSTALLATION INSTRUCTIONS

(All electrical & plumbing should be done in accordance to all local codes)

- Do not use vaseline, oils, other hydrocarbon lubricants or spray silicone anywhere. A silicon lubricant may be used on black o-rings but is not necessary. **Avoid any type of lubricants, including silicone, on red or clear lip seals.**
 - Teflon tape is not necessary on the nut connection or caps because of o-ring seals.
 - The pipe size for the drain line should be a minimum of 3/4". Backwash flow rates in excess of 7 gpm or a drain length in excess of 20' requires 1" drain line.
1. Place the conditioner where you want to install it, making sure it is on a clean, level and firm base.
 2. Do all necessary plumbing (inlet to inlet, outlet to outlet and drain line to drain).
 3. **A jumper ground wire should be installed between the inlet and outlet pipe whenever the metallic continuity of a water distribution piping system is interrupted. Install jumper ground wire on metal pipes.**
 4. The drain connection is made using either 3/4" or 1" female adapter. (See figure 6a) If soldering, joints near the drain fitting must be done prior to connecting the drain line flow control fitting. Leave at least 6" between the drain line control fitting and solder joints when soldering pipes that are connected on the drain line control fitting. Failure to do this could cause interior damage to the drain line flow control fitting.

5. The brine refill flow control assembly is installed in an easy to access refill elbow located on top of the control valve. The refill flow control assembly is attached to the control valve with a locking clip. The locking clip allows the elbow to rotate 270 degrees so the outlet can be orientated towards the brine tank.
6. Connect the brine line found in the brine tank to the brine connection on the control valve. The control valve has a standard refill elbow which a 1/2" flexible tube can be connected, see figure 6a. Both elbows use the same refill flow control and retainer. Do not connect the other end of the brine line to the safety brine valve in the brine tank at this time. Make sure the floor is clean beneath the salt tank and that it is level and smooth.
7. A 1/2" (inside diameter) gravity drain line should be connected to the overflow elbow on the side of the brine tank and run to a drain below the level of the elbow. This overflow drainage system provides protection from water damage in the event of a brine shut-off malfunction. Tubing is not provided to do this.

In all cases where an overflow could result in water damage for various reasons, this overflow protection must be used. Do not connect the tubing to the drain line on the control valve discharge line and do not run this line above the overflow elbow height at any point. Provide air gap.

Exploded View

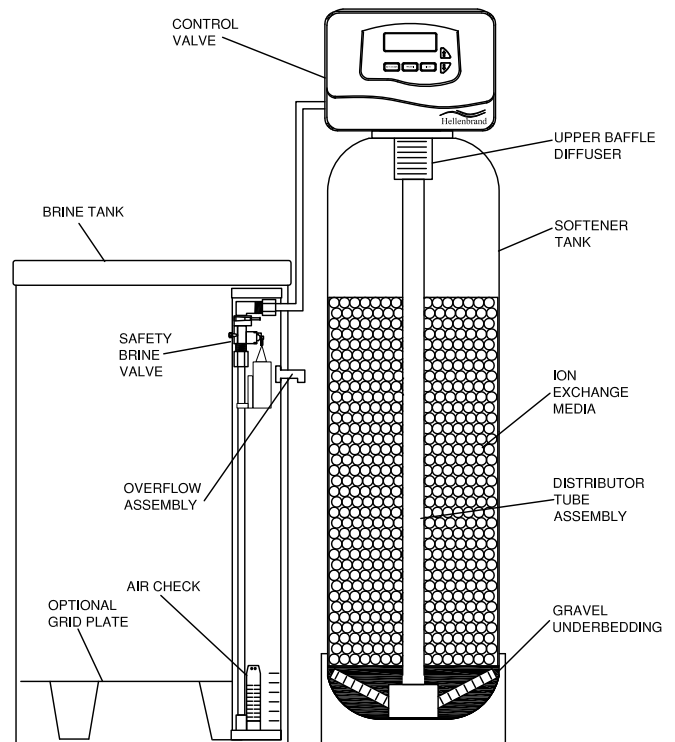
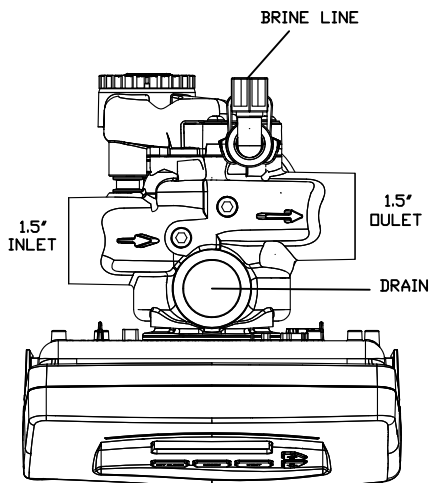
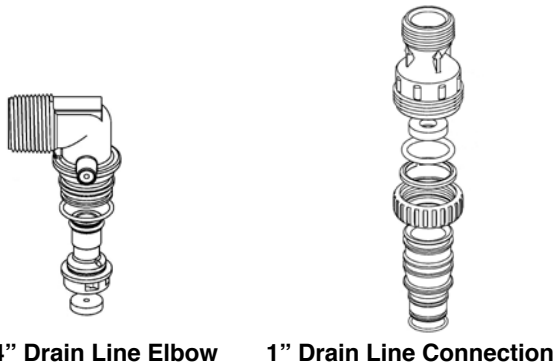

Units larger than 150K contain air check as standard brine tank assembly.

Figure 6a

Figure 6b

INSTALLATION DIAGRAMS

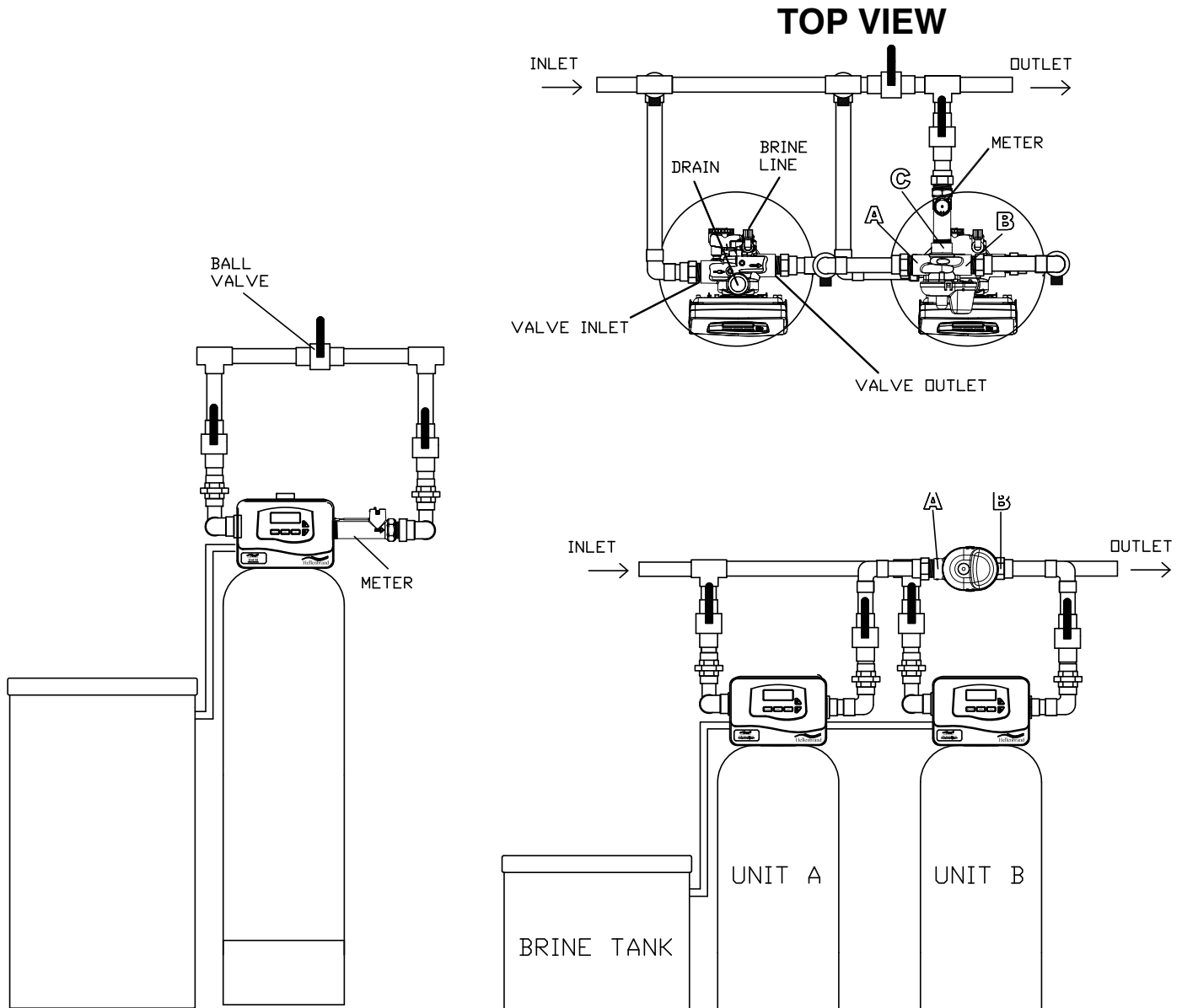

Typical Single Unit Installation Piping

Typical Twin Unit Installation Piping

PROGRAMMING TWIN ALTERNATING SYSTEM WITH MOTORIZED AUXILIARY VALVE (MAV)

When control is programmed as ALT A & ALT B signifying to PC board to operate an alternating system, factory default for reserve setting is "AUTO" and hardness as 20 gpg and capacity to 90% of specified capacity on page 38. This allows 10% safety factor to maintain good quality soft water at end of service run at high flows.

When programmed as an alternator there is not an option to program "OFF" for reserve, as this would cause regeneration on calendar day override, defeating purpose of twin alternating system.

An added benefit of the alternating software is the option of the delayed rinse and fill. When set on, the last two steps of regeneration (rinse & fill) are delayed until right before the unit comes on line. This pre-service rinse will minimize hardness and iron leakage from resin due to a prolonged stagnant mode. This is only available when softening system is programmed as post fill. See page 16.

PROGRAMMING

General Information

The H151 HE control valve is the “brain” of your water softener. It consists of the valve body and powerhead with solid state microprocessor.

The display panel (see Figure 7) consists of the LCD display and five push buttons which are used in displaying and programming the water softener settings.

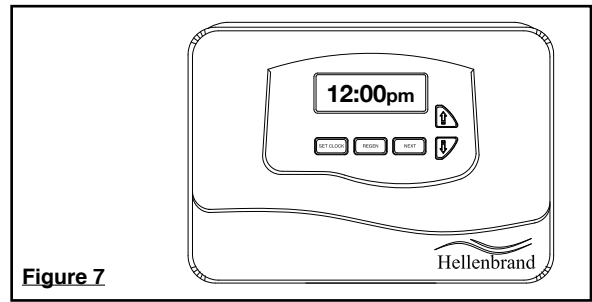

Figure 7

Initial Start Up

The initial start up will probably be done by the technician installing the softener system. If not, the following instructions will step you through the process.

1. Complete all plumbing connections: inlet, outlet, drain line and brine line. Do not add salt at this time.
2. Place the bypass valve in the bypass position. (See page 6) Turn on the main water supply. Open a cold soft water faucet to flush the piping of any air and/or foreign material. Run until the water is clear.
3. Manually add 6 inches of water to the brine tank.
4. Now plug the transformer into a 110-volt receptacle. (Be certain the outlet is uninterrupted.) Within 5 seconds the control will automatically align itself into the softening mode and display will automatically alternate between time of day, gal/min and gallons remaining. (Figure 8).
5. Set the time of day by pushing clock button (figure 9, page 10) and using ▲ and ▼ buttons.
6. Push REGEN button and hold it down for 3 seconds. The system will advance to the “First” position. (Note: Depending on how the system is programmed it could read backwash, rinse, brine or fill). Push REGEN button once per regen step until “Rinse” shows in the upper left hand corner of display. Open bypass to allow water to unit. Run water to the drain until it runs clear. Return the by-pass valve to the by-pass position. Push REGEN button until unit is back to "Softening Mode".
7. Once again, push REGEN button and hold down for 3 seconds. Keep pushing REGEN button until “Backwash” appears. Slowly open inlet valve. Allow water to slowly fill the mineral tank. When a solid stream of water starts coming out of the drain line, open the bypass inlet valve all the way and allow to run out the drain until water clears. Then slowly open the outlet side of valve.
8. Press the REGEN button until LED display says “REGENERANT DRAW DN”. Loosen the brine line from the control valve. Place finger over the brine connection to check for suction. If no suction, see trouble-shooting guide. If proper suction, reattach brine tube to control valve, and allow it to draw water down to the bottom of the air check.
9. Press REGEN button again until LED once again displays “BACKWASH”. Keep in backwash until water once again runs clear at the drain.
10. Press REGEN button again until “RINSE” is displayed. Allow rinse cycle to run its full course. While the rinse cycle is finishing, this would be a good time to load your brine tank with salt. **If utilizing brine recovery, manually add full volume of water to brine tank for the first REGENERATION.**
11. Once the rinse cycle has finished, the softener control will return to refill or the softening cycle. The LED screen will scroll between “TIME/GPM/GALLONS REMAINING” or “DAYS REMAINING/GPM/CUSTOMER SCREEN”.
12. Next set your softeners water hardness, days override and regeneration time settings (see figure 10a, page 10).

Your programming is now complete.

USER DISPLAYS/SETTINGS

General Operation

When the system is operating, one of three displays may be shown. Pressing NEXT will alternate between the displays. One of the displays is the current time of day. The second display is days to a regen/gallons remaining. Days To A Regen is the number of days left before the system goes through a regeneration cycle. Capacity remaining is the number of gallons that will be treated before the system goes through a regeneration cycle. The third display is current flow in gal/min. The user can scroll between the displays as desired by pushing NEXT or display will scroll automatically.

When water is being treated (i.e. water is flowing through the system) the word "GPM" flashes on left side of display when other than flow rate is displayed.

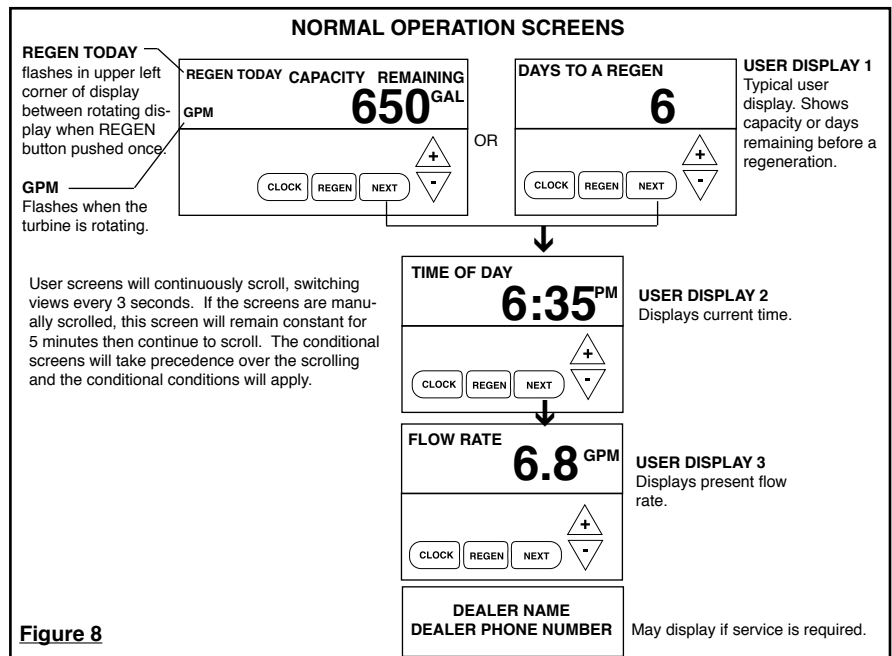
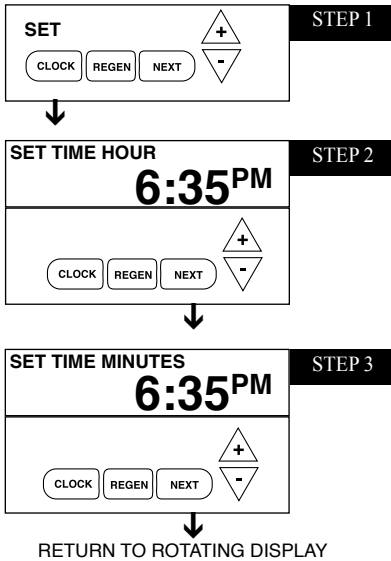

Figure 8

SET TIME OF DAY



▲ = ▲ Up Arrow ▼ = ▼ Down Arrow

Step 1 - Press SET CLOCK.

Step 2 - Current Time (hour): Set the hour of the day using ▲ or ▼ buttons. AM/PM toggles after 12. Press NEXT to go to step 3.

Step 3 - Current Time (minutes): Set the minutes of day using ▲ or ▼ buttons. Press NEXT to exit Set Clock. Press REGEN to return to previous step.

Power Loss - Lithium battery on circuit board provides up to 2 years of time clock backup during power outages. If the power is out when battery is depleted, only time of day needs to be reset, all other values are stored in non-volatile memory. When time of day is flashing, replace lithium coin type 2032 battery.

Battery back-up feature will be activated after 24 hours of power.

Do not forget to reset for daylight savings time.

Figure 9

INSTALLER DISPLAYS/SETTINGS

▲ = ▲ Up Arrow ▼ = ▼ Down Arrow

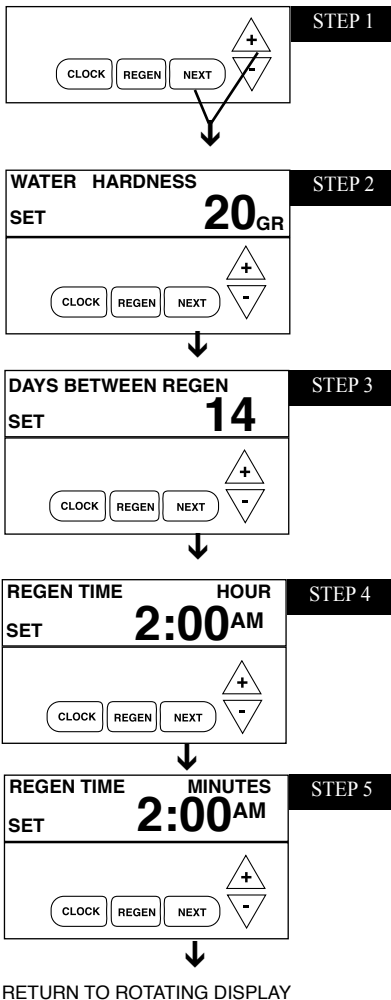

Step 1 - Press NEXT and ▲ simultaneously for 3 seconds.

Step 2 - Hardness: Set the amount of total compensated hardness in grains (hardness as calcium carbonate) per gallon using ▲ or ▼ buttons. **The factory setting is 20** with value ranges from 1 to 150 in 1 grain increments. Note: The grains per gallon should be increased if soluble iron needs to be reduced. Add 3 grains of hardness for each ppm of iron present. If this display shows nA -, then system is set-up in "filter" mode or "AUTO" is not selected in softener system setup. (See page 11). Press NEXT to go to Step 3. Press REGEN to exit Installer Displays/Settings.

Step 3 - Day Override: This sets the number of days between regenerations. If value set to "oFF" regeneration initiation is based solely on gallons used. If value is set as a number (allowable range from 1 to 28) a regeneration initiation will be called for on that day even if sufficient number of gallons were not used to call for a regeneration. Set Day Override using ▲ or ▼ buttons: **Factory setting is 14 days.**

- number of days between regeneration (1 to 28); or
- "oFF"

See figure 12a & b, page 11-12, for more detail on softener setup. Press NEXT to go to step 4. Press REGEN to return to previous step.

Step 4 - Regeneration Time (hour): Set the hour of day for regeneration using ▲ or ▼ buttons. AM/PM toggles after 12. **The factory setting time is 2:00 a.m.** This display will show "REGEN" "IMMEDIATE ON ZERO GAL" if "Immediate" is selected on Step 12 of softener setup. See page 34. Press NEXT to go to step 5. Press REGEN to return to previous step.

Note: When installing this unit as part of a multi unit parallel system the regen time of day must be adjusted to prevent multiple units from regenerating at the same time.

Step 5 - Regeneration Time (minutes): Set the minutes of day for regeneration using ▲ or ▼ buttons. This display will not be shown if system is set for immediate regeneration. Press NEXT to exit Installer Displays/Settings. Press REGEN to return to previous step.

Figure 10a

Manual Regeneration

Sometimes there is a need to regenerate the system, sooner than when the system calls for it, usually referred to as manual regeneration. There may be an unexpected period of heavy water usage.

To initiate a manual regeneration at the preset delayed regeneration time, press and release "REGEN". The words "REGEN TODAY" will flash in left corner of display as it scrolls through displays to indicate that the system will regenerate at the preset delayed regeneration time. If you pressed the "REGEN" button in error, pressing the button again will cancel the request.

To initiate a manual regeneration immediately, press and hold the "REGEN" button for five seconds. The system will begin to regenerate immediately. The request cannot be cancelled. You must cycle all the way through the cycles to make it stop. PLEASE NOTE: This will reset the meter.

Note: If the salt tank does not contain salt, fill with salt and wait at least two hours before regenerating. If two regenerations are desired within 24 hour period, press /release REGEN button. REGEN TODAY will flash on screen. Press and hold REGEN button until valve initiates regeneration.

Regeneration Mode

Typically a system is set to regenerate at a time of low water usage. If there is a demand for water when the system is regenerating, untreated water will be supplied.

When the system begins to regenerate, the display will change to include information about the step of the regeneration process and the time remaining for that step to be completed (see figure 11). The system runs through the steps automatically and will reset itself to provide treated water when the regeneration has been completed.

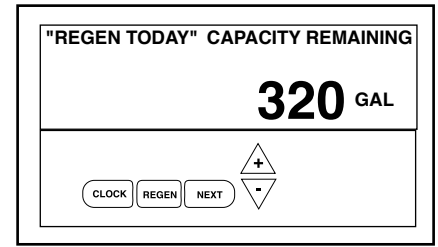

Regeneration Step
(shows time remaining in regen step
is 8 minutes, 22 seconds)

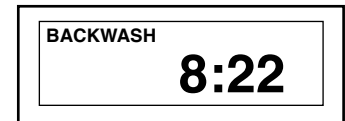

Figure 11

CYCLE TIME ADJUSTMENTS

Normally it is not recommended to adjust the lengths of the cycle times. However, certain water conditions may dictate adjustments. This should only be done from the recommendation of a water conditioning professional. The following chart shows the upper and lower limits of each cycle.

Cycle Options	Units	Lower/Upper Limit
Service	NA	NA
Refill Brine Tank	Lbs or Minutes	0.1 -200 Lbs to 0.1-99 Min
Softening	Mins	1 to 480
Regenerant Draw UP	Mins	1 to 180
Backwash	Mins	1 to 120
Fast Rinse	Mins	1 to 120

SOFTENER SETUP

▲ = ▲ Up Arrow ▼ = ▼ Down Arrow

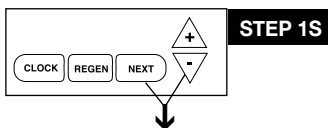

STEP 1S

STEP 1S – Press NEXT and ▼ simultaneously for 3 seconds. If screen in Step 2S does not appear in 5 seconds the lock on the valve is activated.

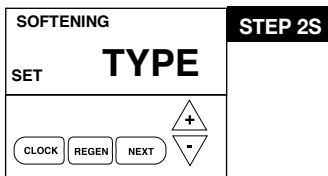

STEP 2S

STEP 2S – Select between softening or filtering. A flashing "SOFTENING" or "FILTERING" will appear. Choose SOFTENING using ▼ or ▲ button. **Factory setting is Softening.** Press NEXT to go to Step 3S. Press REGEN to exit Softener System Setup.

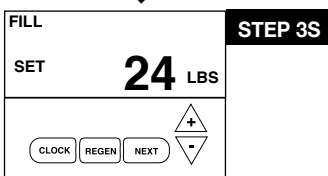

STEP 3S

STEP 3S – Select the time for the first cycle (which in this example is FILL) using the ▼ or ▲ button. Press NEXT to go to Step 4S. Press REGEN to return to the previous step.

STEP 4S

SOFTENING

SET 120 MIN

CLOCK REGEN NEXT

STEP 4S – Select the time for the second cycle (which in this example is SOFTENING) using the ▼ or ▲ button. Press NEXT to go to Step 5S. Press REGEN to return to the previous step.

STEP 5S

DRAW UP TIME

SET 84 MIN

CLOCK REGEN NEXT

STEP 5S – Select the time for the third cycle (which in this example is DRAW UP TIME) using the ▼ or ▲ button. Press NEXT to go to Step 6S. Press REGEN to return to the previous step.

STEP 6S

BACKWASH TIME

SET 12 MIN

CLOCK REGEN NEXT

STEP 6S – Select the time for the fourth cycle (which in this example is BACKWASH, setting) using the ▼ or ▲ button. Press NEXT to go to Step 7S. Press REGEN to return to previous step.

STEP 7S

RINSE TIME

SET 8 MIN

CLOCK REGEN NEXT

STEP 7S – Select the time for the fifth cycle (which in this example is RINSE TIME, setting) using the ▼ or ▲ button. Press NEXT to go to Step 8S. Press REGEN to return to previous step.

STEP 8S

GRAIN OF CAPACITY

SET FILL

CLOCK REGEN NEXT

STEP 8S – Select between proportional or normal brining. Using the ▼ or ▲ button to select **Proportional brining is only available if configured as prefill/upflow softener or screen will not appear.** Proportional brining will divide the actual gallons used by calculated volumetric capacity then multiply fill volume by this percentage. If regeneration is initiated by calendar day override it will brine proportionately; minimum 20% of pre-programmed amount. This option requires a functioning meter. **Factory Setting = Normal brining.** Press NEXT to go to Step 9S. Press REGEN to return to previous step.

STEP 9S

GRAIN OF CAPACITY

SET 84.0 x1K

CLOCK REGEN NEXT

STEP 9S - Set Grain Capacity using the ▼ or ▲ button. The ion exchange capacity is in grains of hardness as calcium carbonate for the system based on the pounds of salt that will be used. The allowable grains capacity range varies from 5,000 to 500,000 grains. The increment increase is 500 for the range from 5000 to 50,000; 1000 for the range of 50,000 to 200,000; and 2000 for the range of 200,000 to 500,000. Grains capacity is affected by the fill time. The grains capacity for the selected lbs. salting should be confirmed by testing. The capacity and hardness levels entered are used to automatically calculate reserve capacity when gallon capacity is set to AUTO. **Factory setting is the capacity of the softener at low salting. See Page 38.** Press NEXT to go to Step 10S. Press REGEN to return to previous step.

STEP 10S

RESERVE CALCULATOR

SET AUTO

CLOCK REGEN NEXT

STEP 10S – Set Gallons Capacity using ▼ or ▲ button. If value is set to:

- “AUTO” gallon capacity will be automatically calculated and reserve capacity will be automatically estimated;
- “oFF” regeneration will be based solely on the day override set (see Installer Display/Settings Step 3, page 9 / proportional brining will not function if OFF selected); or
- as a number of gallons (allowable range 20 to 250,000) regeneration will be based on the value specified. Increment increase is 20 for the range 20 to 2000, 100 for the range of 2000 to 10,000 and 500 for the range of 10,000 to 50,000 and 2000 for range of 50,000 to 250,000.

If “oFF” or a number is used, hardness cannot be set in Installer Displays/Settings Step 2, page 9. See page 32 for more detail. **Factory Setting is AUTO.** Press NEXT to go to Step 10S. Press REGEN to return to previous step.

STEP 11S

DELAY + IMMEDIATE

SET REGEN

CLOCK REGEN NEXT

STEP 11S – Set Regeneration Time Options using the ▼ or ▲ button. If value is set to:

- “DELAY” means regeneration will occur at the preset time; if control is set as Twin Alt, alternation will occur on zero, but regeneration is delayed to preset time.
- “IMMEDIATE” means regeneration will occur immediately when the gallons capacity reaches 0 (zero); or
- “DELAY + IMMEDIATE” means regeneration will occur at one of the following:
 - the preset time when the gallons capacity falls below the reserve or the specified number of days between regenerations is reached, whichever comes first; or
 - immediately after 10 minutes of no water usage when the gallon capacity reaches 0 (zero).

See page 32 for more options. **Factory Setting is DELAY + IMMEDIATE.** If control is set as Twin Alternating, this option is not available. Press NEXT to go to Step 10S. Press REGEN to return to previous step.

RELAY 1 "TIME"
SET TRIGGER

CLOCK REGEN NEXT

↑
-

STEP 12S

STEP 12S – Set Relay to activate by Time, Gallons, Regen Gallons, Off or Service Alarm by using ▼ or ▲ buttons. A relay can be used to operate a chemical feed pump or solenoid. The choices are:

- **Relay Triggered on Time** - Relay activates after set number of minutes after start of regeneration. Start of regeneration is defined by first backwash cycle, dn brine or up brine, whichever is first. Relay deactivates after set time. (Range: 0 – 500 minutes)
- **Relay Triggered on Gallons** - Relay activates every set number of gallons while in service and deactivates after set time. (Range: 0.1 – 20,000 gallons)
- **Relay Triggered on Regen Gallons** - Relay activates after set number of gallons in service or gallons used during regeneration and de-activates after set time or when meter stops registering flow, whichever comes first. (Range: 0.1 – 20,000 gallons)
- **Service Alarm** - Relay activates on service alarm setting: gallons, time or both, see step 23S.
- **Relay Triggered for Lock Out** - Relay activates after set number of minutes into regeneration. A zero or positive start time references the first backwash or brine cycle as start. "Regen" can be selected for time setting to activate relay for entire regeneration cycle; 2 minutes before and 1 minute after. "Regen" can be selected as lockout setpoint by pressing down arrow through all negative numbers. (Range -20 – 500 minutes)
- **Off** - If off is selected, Steps 13S – 23S will not be shown. **Factory setting = OFF**. Press NEXT to go to step 13S or other selection for relay settings, or 20S if OFF selected.

RELAY 1 SET POINT
SET 10 MIN

CLOCK REGEN NEXT

↑
-

STEP 13S

STEP 13S – If off was selected in previous step, this screen does not appear.

If Time chosen to Activate Relay, use up and down arrows to set # of minutes AFTER START OF REGEN to activate relay. Start of regeneration is defined as first Backwash or Regenerant Draw mode. Press NEXT to go to Step 14S.

RELAY 1 DURATION
SET 3:00 MIN

CLOCK REGEN NEXT

↑
-

STEP 14S

STEP 14S – Use Up and Down arrows to set duration of relay activation in minutes.

Time Range = Negative 20 minutes to a positive 500 minutes. Press NEXT to go to Step 22S. Press REGEN to return to previous step.

RELAY 1 "GALLONS"
SET TRIGGER

CLOCK REGEN NEXT

↑
-

STEP 15S

STEP 15S – Gallons chosen to activate relay. If Off or Time was selected in previous steps, this screen does not appear. Press NEXT to set # of gallons per relay activation.

RELAY 1 SET POINT
SET 1 GAL

CLOCK REGEN NEXT

↑
-

STEP 16S

STEP 16S – Use up and down arrows to set # of gallons per relay activation. Range = 0.1–20,000 gallons. Press NEXT to set duration of relay activation.

RELAY 1 DURATION
SET 0:01 MIN

CLOCK REGEN NEXT

↑
-

STEP 17S

STEP 17S – Use up and down arrows to set duration of relay activation in minutes.

Range = 1 second - 500 minutes (0:01–500:00). Press NEXT to go to Step 22S. Press REGEN to return to previous step.

RELAY 1 "REGEN GALLONS"
SET TRIGGER

CLOCK REGEN NEXT

↑
-

STEP 18S

STEP 18S – If REGEN gallons chosen to activate relay. Relay activates after set number of gallons have been used in service or during regeneration and then deactivates after set period of time or after flow stops, whichever comes first. Range = 0.1–20,000 gallons. Press NEXT to go to Step 19S.

RELAY 1 SET POINT
SET 1 GAL

CLOCK REGEN NEXT

▲
▼

STEP 19S

STEP 19S – Use up and down arrows to select number of gallons per relay activation of regen gallon setting. Range: 1 -100 gallons. Press NEXT to go to Step 20S.

RELAY 1 DURATION
SET 0:01 MIN

CLOCK REGEN NEXT

▲
▼

STEP 20S

STEP 20S – If Off or Time was selected in previous steps, this screen does not appear. Use up and down arrows to set duration of relay activation in minutes. Range = 1 second - 500 minutes. Press NEXT to go to Step 22S. Press REGEN to return to previous step. Meter does not read during regeneration.

RELAY 1 SERV ALARM
SET TRIGGER

CLOCK REGEN NEXT

▲
▼

STEP 21S

STEP 21S

If Service Alarm chosen to activate relay, relay closes whenever Service Alarm has triggered. Programming for relay closure on service reminder is done on Step 24S. Relay opens when service alarm reset. Press NEXT to go to Step 22S to set Relay 2 Settings. If off selected for Relay 2, Press NEXT to go to step 23S for service reminder programming.

- Relay closes on Gallons
- Relay closes on Time
- Relay closes on Both
- Off

RELAY 2 TRIGGER
SET REGEN GAL

CLOCK REGEN NEXT

▲
▼

STEP 22S

STEP 22S – Relay 2 programming includes identical options as Relay 1 with the addition of the ability to trigger Relay 2 in Error Mode. Relay closes when ever control enters Error Mode and immediately deactivates when error resolved and control reset. Press NEXT to go to Step 21S.

SERVICE REMINDER

SERVICE ALARM
SET BOTH

CLOCK REGEN NEXT

▲
▼

STEP 23S

STEP 23S – Set scheduled service display using ▲ or ▼ buttons. Available options are OFF, TIME, ON GAL or BOTH. Selecting OFF disables this feature. If OFF is selected, press NEXT to exit System Setup. If TIME, ON GAL or BOTH is selected press NEXT to select the TIME and/or ON GAL values. See Steps 24S and/or 25S. This can also activate relay if Service Alarm is selected on Step 21S. Press REGEN to return to the previous step.

SCHEDULED SERVICE
SET 0.25 YR

CLOCK REGEN NEXT

▲
▼

STEP 24S

STEP 24S – Service alarm for TIME ranges from 0.25 to 9.75 years. Use ▲ or ▼ buttons to select length of time between service reminders. Press NEXT to either exit System Setup or if BOTH was selected go to Step 25S. Press REGEN to return to the previous step. When time selected and # of days drops below 1 year, the next display will show “scheduled service in XXX days” after screen where service reminder is programmed.

SCHEDULED SERVICE
SET 80000 GAL

CLOCK REGEN NEXT

▲
▼

STEP 25S

STEP 25S – Service alarm for ON GAL ranges from 100 to 9,999,000 gallons. Hold ▲ or ▼ buttons until display flashes “SET” before releasing to select values. Press NEXT to see “Gallons until service” displays. Press NEXT to exit system. Press REGEN to return to the previous step.

Reset service reminder by holding down up and down arrows together when reminder is displayed.

RETURN TO NORMAL MODE

DIAGNOSTICS

To reset diagnostic data push "Next" and ▼ button until TYPE appears in window, then press "▲ & ▼" button simultaneously for 3 seconds.

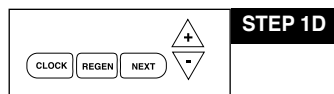

STEP 1D

STEP 1D – Press ▼ or ▲ simultaneously for three seconds. If screen in step 2D does not appear in 5 seconds the lock on the valve is activated.

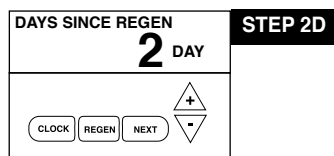

STEP 2D

STEP 2D – Days, since last regeneration: This display shows the days since the last regeneration occurred. Press the NEXT button to go to Step 3D. Press REGEN to exit Diagnostics.

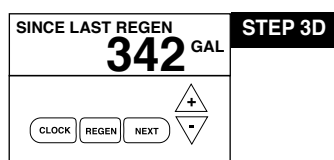

STEP 3D

STEP 3D – Volume, since last regeneration: This display shows gallons of water that has been treated since the last regeneration. This display will equal zero if a water meter is not installed. Press the NEXT button to go to Step 4D. Press REGEN to return to previous step.

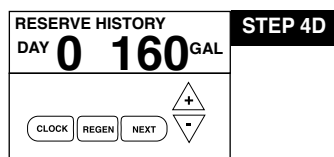

STEP 4D

STEP 4D – Volume of reserve capacity used for last 7 days: If the unit is set up as a softener, a meter is installed and Set Volume Capacity is set to "Auto", this display shows 0 day (for today) and the reserve capacity. Pressing the ▲ button will show day 1 (which would be yesterday) and displays the reserve capacity. Pressing the ▲ button again will show day 2 (the day before yesterday) and the reserve capacity. Keep pressing the ▲ button to show the capacity for days 3, 4, 5 and 6. The ▼ button can be pressed to move backwards in the day series. Press NEXT button at any time to go to Step 5D. Press REGEN to return to previous step.

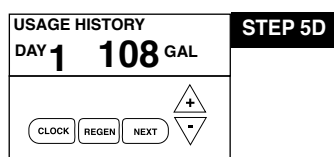

STEP 5D

STEP 5D – Volume of water used, 63-day usage history: This display shows day 0 (for today) and 1 (for yesterday) will show day 2 (which would be the day before yesterday) and flashes the volume of water treated on that day. Continue to press the ▲ button to show the volume of water treated for the last 63 days. If a regeneration occurred on the day the "letter R" will also be displayed. This display will show dashes if a water meter is not installed. Press the NEXT button at any time to go to Step 6D. Press REGEN to return to the previous step.

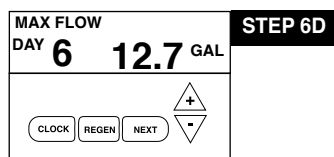

STEP 6D

STEP 6D – Flow rate, maximum of each of last seven days: The maximum flow rate in gallons per minute that occurred in each of the last seven days will be displayed. Press ▲ arrow to display maximum flow rate today = 0, yesterday = 1. This display will equal zero if a water meter is not installed. Press the NEXT button to exit Diagnostics. Press REGEN to return to the previous step.

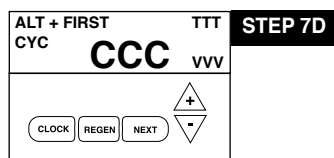

STEP 7D

STEP 7D – MAV Drive History – Not displayed if MAV set to off.

- First - Average of 1st three drive times of MAV in that direction
- Last - Last drive time measured for that MAV in that direction
- Ave - Average drive time measured for MAV in that direction
- TTT - Drive time (1424 = 14.24 seconds)
- CCC - Total number of cycles for that MAV
- VVV - Relative drive voltage

MAV drives piston "in" is designated by (-) sign.

MAV drives piston "out" is designated by (+) sign.

RETURN TO NORMAL MODE

Any time MAV is rebuilt or replaced, reset diagnostics to reflect new drive characteristics.

VALVE HISTORY (Can not be reset)

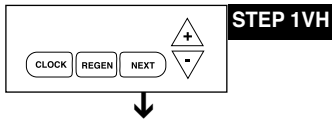

STEP 1VH – Press ▼ and ▲ simultaneously for three seconds and release, then press ▼ and ▲ simultaneously and release. If screen in step 2VH does not appear in 5 seconds the lock on the valve is activated.

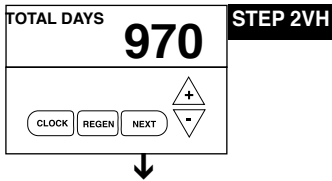

STEP 2VH – Days, total since start-up: This display shows the total days since startup. Press the NEXT button to go to Step 3VH. Press REGEN to return to previous step.

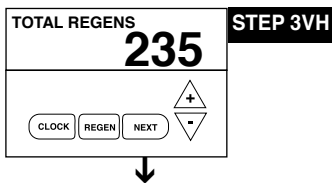

STEP 3VH – Regenerations, total number since start-up: This display shows the total number of regenerations that have occurred since startup. Press the NEXT button to go to Step 4VH. Press REGEN to return to previous step.

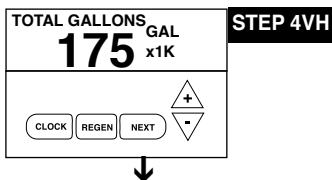

STEP 4VH – Volume, total used since start-up: This display shows the total gallons treated since startup. This display will equal zero if a water meter is not installed. Press NEXT button to exit Valve History. Press REGEN to return to previous step.

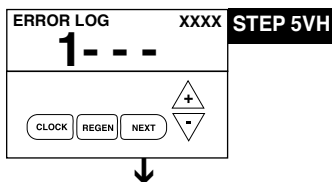

STEP 5VH – Error Log history: up to 10 errors. Press ▼ and ▲ buttons to view each recorded error. If no errors have occurred “- - - -” is displayed. With STALL ERRORS 102, 107, 117. Right upper corner of display indicates piston position at time of stall. Press NEXT to exit valve history.

RETURN TO ROTATING DISPLAY

CYCLE SEQUENCE

Anytime cycle sequence is modified, softener set-up will revert to manufacturer setting and must be reprogrammed as desired.

Cycle Sequence instructions allows the operator to set the order of the cycle. The Softener System Setup allows the operator to set how long the cycles will last. The operator may choose up to 9 cycles in any order.

END must be used as the last cycle option. The SOFTENING cycle should only be used in brine prefill applications to allow salt to dissolve.

The following is an example of how to set a valve so that when regeneration is initiated, BACKWASH occurs first, REGENERANT DRAW DN occurs second, RINSE occurs third, and FILL occurs fourth.

Cycle Options		
BACKWASH	REGENERANT DRAW-UP	FILL
RINSE	SOFTENING	END

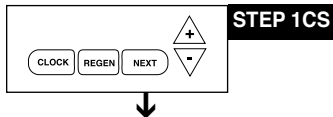

STEP 1CS – Press NEXT and ▼ simultaneously until TYPE appears on screen and release. Then press NEXT and ▼ simultaneously again for 3 seconds and release. If screen in step 2CS does not appear in 5 seconds the lock on the valve is activated.

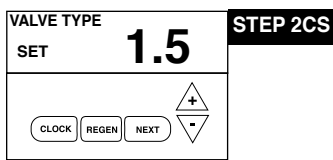

STEP 2CS – Valve Type. Use the ▲ or ▼ to select from 1.0", 1.25", 1.50", 2.0L", 2.0" valve. H151 HE is a 1.5" valve. Press NEXT to go to Step 3CS.

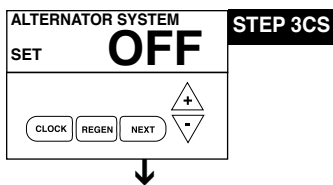

STEP 3CS – Use the ▲ or ▼ to select one of the following:

- OFF; or
- Twin Alternating – Select Alt A or Alt B – See instructions in Step 4CS.
- System Board - Allows Demand Recall Programming – See instructions in Step 9CS.
- No Hard Water Bypass During Regeneration– See instructions in Step 6CS.
- Reclaim Enabled - Allows control to operate in Reclamation Mode – See instructions in Step 8CS.
- Separate Source Enabled - Allows control to have a separate water source during the regeneration cycle– See instructions in Step 7CS
- **Factory Setting is OFF** - Press NEXT to go to Step 10CS.

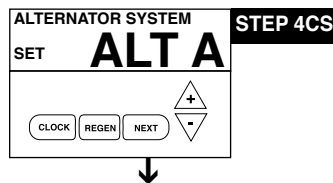

STEP 4CS –Twin Alternating System – Allows automatic alternation between two units to provide softened water 24 hours a day.

Use ▲ or ▼ buttons to select ALT A or ALT B

Select ALT A for the control valve that has the two-pin connector labeled MAV connected to the alternator valve.

Select ALT B for the control valve that will be connected via three-prong connector labeled COMM CABLE. Must use 3-wire interconnect cable. Press NEXT to go to Step 5CS.

For Alternating System, change programming:

- Set softener, with volume capacity in GALLONS and select Regeneration Time Option "IMMEDIATE" or "DELAYED" and select DAYS BETWEEN REGEN as desired.
- For complete programming, see Twin Alternating MAV manual.

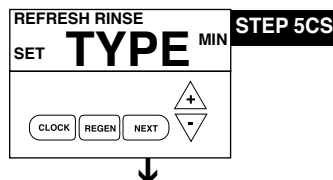

STEP 5CS – Select Twin Alternating Option.

Use ▲ or ▼ buttons to select

- Standard - Standard Alternating Function
- Refresh Rinse - Alternates every 6am & 6pm and runs programmable number of gallons to service. Press NEXT to set number of gallons.
- Delayed Rinse and Fill- See below
- **Factory Setting is Standard Alternating Function**

This option delays the last two cycles of regeneration (only "Rinse" and "Fill"). This feature splits the regeneration into two portions. The first portion of the regeneration will start immediately and all programmed cycles before the "Rinse" and "Fill" cycles will be performed. After all programmed cycles before "Rinse" and "Fill" are completed the control valve will drive to the service position (displaying "Delayed Rinse + Fill Pending"). When the volume of the on-line unit is depleted to 10% of its programmed capacity, the control valve will be triggered to finish the second portion of the regeneration and complete the "Rinse" and "Fill" cycles and return to Service and be placed into Standby mode, and wait to come on-line for service. Press NEXT to go to Step 10CS.

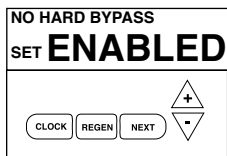

STEP 6CS

STEP 6CS – No Hard Water Bypass Enabled - Use ▲ or ▼ buttons to select NO HARD WATER BYPASS ENABLE. Selection requires that a connection to a Motorized Alternator Valve (MAV) is made to the two pin-connector labeled MAV DRIVE located on the printed circuit board. The MAV will be driven closed before the first regeneration cycle that is not FILL or SOFTENING or FILTERING, and be driven open after the last regeneration cycle that is not FILL. NOTE: If the control valve enters into an error state during regeneration mode, the no hard water bypass valve will remain in its current state until the error is corrected and reset. Reset by pushing NEXT & REGEN buttons simultaneously until display changes. Press NEXT to go to Step 10CS.

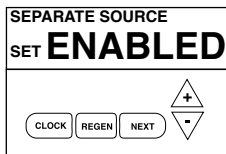

STEP 7CS

STEP 7CS – Configuring the Control Valve for Separate Source Operation - Select Separate Source Enabled for control operation. For separate source operation, the three wire connector is not used. Selection requires that a connection to a MAV is made to the two pin connector labeled MAV DRIVE located on the printed circuit board. The C port of the MAV must be connected to the valve inlet and the A port connected to the separate source used during regeneration. The B port must be connected to the feed water supply. When set to Separate Source Enabled the MAV will be driven closed before the first regeneration cycle, and be driven to open after the last regeneration cycle. NOTE: If the control valve enters into an error state during regeneration mode, the MAV will remain in its current state until the error is corrected and reset. Reset by pushing NEXT & REGEN buttons simultaneously until display changes.

STEP 8CS – Configuring the Control Valve for Water Reclamation Mode - Select Reclaim Enabled for control operation. Motorized Alternating Valve will advance to Bypass at a set time after the beginning of regeneration, and return to Service after a set duration. This allows water to be diverted from drain for reuse. Up to three bypass events are possible. Select reclaim enabled for 1 reclaim event, reclaim 2x for two reclaim events, reclaim 3x for three reclaim events.

The Alternating MAV transitions to Bypass at the set time after the start of regeneration. The start of regeneration is defined as the first cycle that is not FILL, SOFTENING or FILTERING. The Alternating MAV will transition back to Service after the completion of the preset duration time.

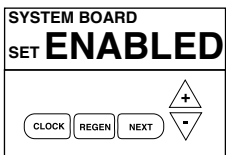
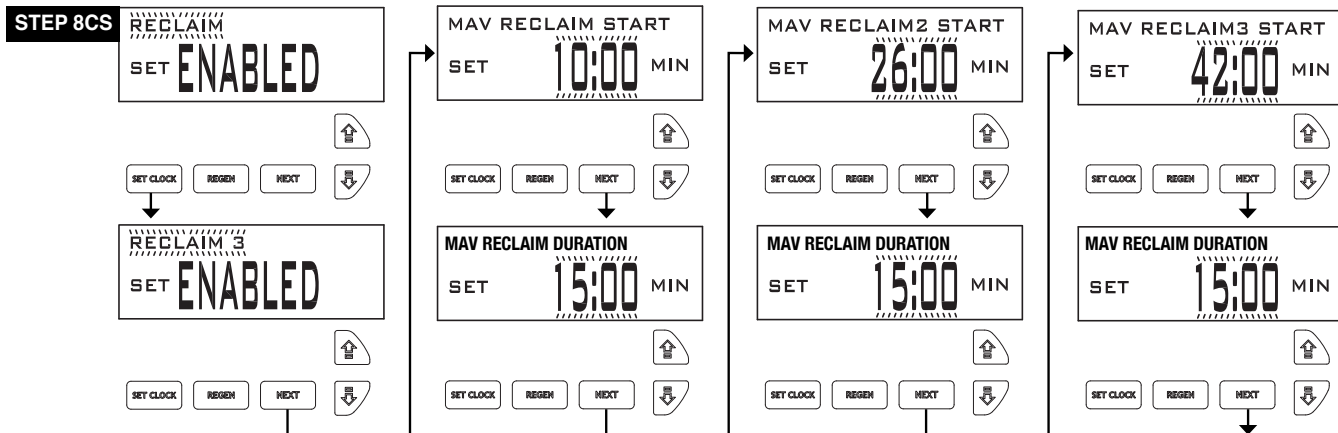

STEP 9CS

STEP 9CS – Configuring the Control Valve to operate with the Hellenbrand System Controller - Select System Board Enabled to link the Control Valve to the SystemMate Controller. For communication between the Control Valve and the System Controller, a three-wire communication cable is required.

Press NEXT to go to Step 10CS. Press REGEN to return to previous step.

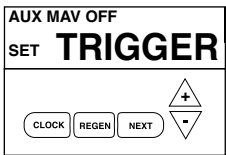

STEP 10CS

STEP 10CS – Use the ▲ or ▼ buttons to select one of the following:

- **Reclaim** – Allows brine reclamation. Select Reclaim for 1 Reclaim Event, Reclaim 2x for 2 reclaim events and Reclaim 3x for 3 reclaim events.
- **Separate Source** – Allows Auxiliary MAV to switch positions before the start of regeneration and to switch back at the end of regeneration. See instructions in Step 13CS.
- **Off - Factory Setting is Off**

Press NEXT to go to Step 11CS when reclaim selected as trigger. Press REGEN to return to previous step.

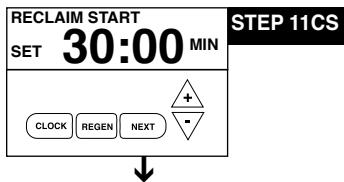
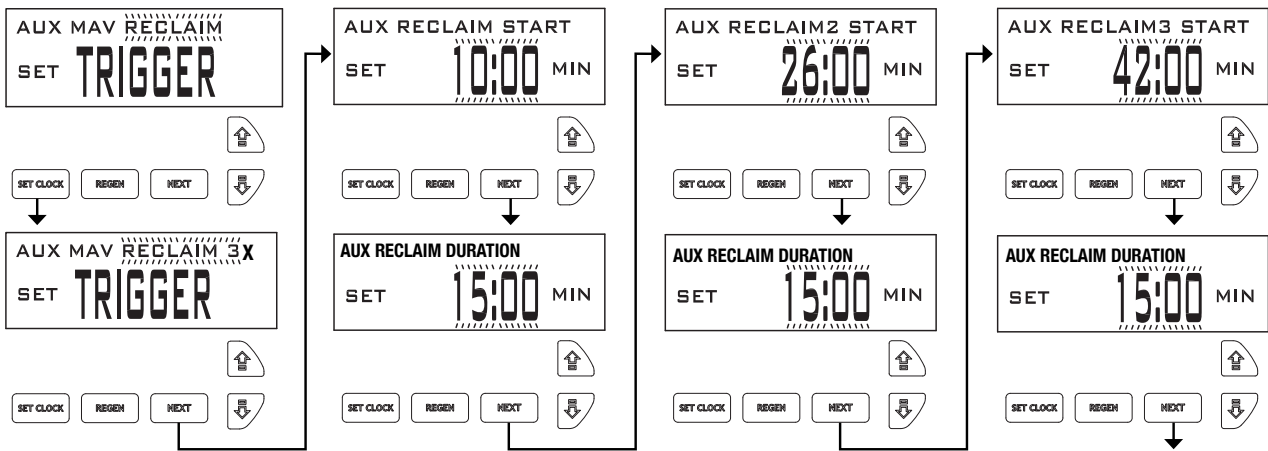

STEP 11CS – Only displays if reclamation of brine is enabled in Step 10CS. Use the ▲ or ▼ buttons to select the number of minutes after the start of regeneration before the MAV will divert the brine waste water from the plumbing drain receptacle to the brine tank. Start of regeneration is defined as any mode that is not fill or softening.

Press NEXT to go to Step 12CS. Press REGEN to return to previous step.

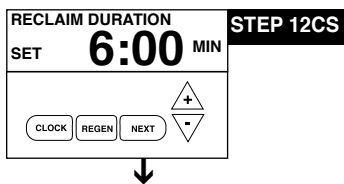

STEP 12CS – Only displays if reclamation of brine is enabled in Step 10CS. Use the ▲ or ▼ buttons to select the number of minutes to divert the brine waste water to the brine tank. After the minutes count down to zero the waste water will once again be diverted to the plumbing drain receptacle.

Press NEXT to go to Step 13CS. Press REGEN to return to previous step.

Brine Reclaim: When Reclaim is selected as trigger for Auxilliary MAV Drive, a portion of the brine can be diverted after it has passed through the resin bed. Brine discharge contains unused salt that can be used for brine make-up for the next regeneration. A motorized alternator valve (MAV) must be connected to the two-pin connector labeled AUX 1 located on the circuit board or error code 106 will result. The MAV diverts the brine discharge to brine tank. A-Port discharges to brine tank. B-Port discharges to drain, remaining port connects to the valve drain fitting. For start time and duration settings an elution study must be done to provide settings that optimize salt savings without sacrificing capacity.

H151 HE Super HP Software REV (P101, P100.11 & >) defines start of regeneration as any mode that is not fill or softening.

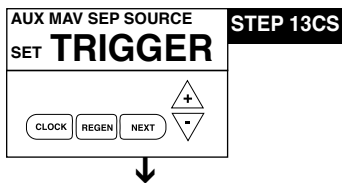

STEP 13CS – Separate source selection requires connection of motorized alternator valve (MAV) to Auxiliary Drive two-pin connection on board.

Auxiliary MAV Drive set to operate with a Separate Source trigger. Auxiliary MAV transitions to Bypass before the start of regen cycle #1, AFTER Alternator MAV motor transition. Auxiliary MAV transitions back to Service at the completion of the last programmed regen cycle, once the Valve Motor deactivates and BEFORE Alternator MAV transition (if scheduled). Auxiliary MAV will NOT automatically return to Service while manually stepping valve through regen, MAV will remain in Bypass until regen cycle ends or NEXT & REGEN buttons pushed simultaneously until display changes. Press NEXT to go to Step 14CS. Press REGEN to return to previous step.

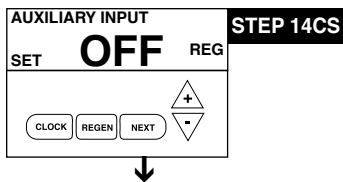

STEP 14CS – This display will be available to select the use of an outside signal to control the initiation of a regeneration. Selection only matters if a connection is made to the two pin connector labeled DP SWITCH located on the printed circuit board. Following is an explanation of the options:

- IMMED REGEN – If the dP switch is closed for an accumulative time of 2 minutes, a regeneration will occur immediately.
- DELAY REGEN – If the dP switch is closed for an accumulative time of 2 minutes, a regeneration will occur at the schedule regeneration time.
- HOLD REGEN – If the dP switch is closed a regeneration will be prevented from occurring.
- OFF - Factory setting is off

Press NEXT to go to Step 15CS. Press REGEN to return to previous step.

FILL
SET **CYCLE 1** **STEP 15CS**

CLOCK REGEN NEXT

STEP 15CS – Press the ▲ or ▼ buttons until selection of first cycle appears in left upper corner, in this example FILL is selected. Press NEXT to go to Step 16CS. Press REGEN to return to previous step.

SOFTENING
SET **CYCLE 2** **STEP 16CS**

CLOCK REGEN NEXT

STEP 16CS – Press the ▲ or ▼ buttons until selection of second cycle appears in left upper corner, in this example SOFTENING is selected. Press NEXT to go to Step 17CS. Press REGEN to return to previous step.

REGENERANT DRAW UP
SET **CYCLE 3** **STEP 17CS**

CLOCK REGEN NEXT

STEP 17CS – Press the ▲ or ▼ buttons until selection of third cycle appears in left upper corner, in this example REGENERANT DRAW UP is selected. For a H151 HE control valve: prior to selecting DN or UP or not selecting a regenerant flow cycle, verify the correct valve body, main piston, regenerant piston and stack are being used and the injector or injector plug(s) are in the correct location. Press NEXT to go to Step 18CS. Press REGEN to return to previous step.

BACKWASH
SET **CYCLE 4** **STEP 18CS**

CLOCK REGEN NEXT

STEP 18CS – Press the ▲ or ▼ buttons until selection of fourth cycle appears in left upper corner, in this example BACKWASH is selected. Press NEXT to go to Step 19CS. Press REGEN to return to previous step.

RINSE
SET **CYCLE 5** **STEP 19CS**

CLOCK REGEN NEXT

STEP 19CS – Press the ▲ or ▼ buttons until selection of fifth cycle appears in upper left corner. Press NEXT to go to Step 20CS. Press REGEN to return to previous step.

END
SET **CYCLE 6** **STEP 20CS**

CLOCK REGEN NEXT

STEP 20CS – Press the ▲ or ▼ button until last regeneration cycle; END appears (up to 9 regeneration modes are possible). **End must be selected as last cycle.** Press NEXT to go to Step 21CS.

FILL UNITS
SET **LBS** **STEP 21CS**

CLOCK REGEN NEXT

STEP 21CS – Press the ▲ or ▼ button to select “LBS” or MIN as brine tank fill units. Select LBS with standard 0.5 gm brine refill flow control. Select minutes if using larger brine refill flow control. **Factory setting is Minutes.**

ALT FILL TRIGGER
SET **REGENS OFF** **STEP 22CS**

CLOCK REGEN NEXT

STEP 22CS – Press the ▲ or ▼ button to select number of standard regenerations which would trigger one alternate brine fill amount. Range: 1-99. **Factory setting is Off.** Press NEXT to go to Step 23CS.

ALT FILL AMOUNT
SET **15.0 LBS** **STEP 23CS**

CLOCK REGEN NEXT

STEP 23CS – Select amount of salt to be used when alternate regeneration requested. This screen is not displayed if off is selected in previous step. Softener Range 0.1–200 lbs. Filter Range 0.05–20.0 Gallons.

WATER SOFTENER DISINFECTION

The construction materials of your water softener will not support bacterial growth nor will these materials contaminate a water supply. However, the normal conditions existing during shipping, storage, and installation indicate the advisability of disinfecting a softener after installation, before the softener is used to treat potable water. In addition, during normal use a softener may become fouled with organic matter or in some cases, with bacteria from the water supply.

Therefore, every water softener should be disinfected after installation, some will require periodic disinfection during their normal life. You have two choices for disinfection as follows:

- A. SODIUM HYPOCHLORITE (household bleach)
5.25% SODIUM HYPOCHLORITE solutions are available under

such trade names such as Clorox, Linco, Bo Peep, White Sail and Eagle Brand Bleach. If stronger solutions are used, such as those sold for commercial laundries, adjust the dosage accordingly.

- 1. Dosage:
 - a. Softening resin; 1.2 fluid ounce per cubic foot of resin.
- 2. Add the required amount of hypochlorite solution to the brine well of the brine tank.
 - a. Proceed with the normal regeneration. Press REGEN and allow the water softener to go through a normal regeneration.
- B. EPA and NSF approved Sani-System by Pro Products.
This can be purchased from your water treatment provider or at: <http://proproducts.com/products/sani-system>.

WATER SOFTENER DRAINING PROCEDURE

In cold weather climates it is common for plumbing systems that are not in use to be “winterized” or drained of all water to prevent any damage that may be caused by the excessive expansion of water when it freezes. To prevent damage to a water softener it must be **properly** drained also. A simple way to properly drain or winterize a water softener is to use compressed air to force all of the water out of the softener mineral tank. The following procedure will explain the process:

- 1) Initiate the softener into a manual regeneration cycle. After the refill cycle, advance control to backwash and allow it to complete the backwash cycle (this will clean the media) and start into the brine-draw cycle. Allow the regeneration to continue in the brine draw cycle until the brine is drawn out of the brine tank and the air check at the bottom of the brine pick-up tube shuts off. At this time no more brine is introduced into the softener and the slow rinse process begins.
- 2) Turn the water supply inlet and outlet valves off to the water softener as soon as the air check shuts off and no more brine is being drawn into the softener (at the beginning of the slow rinse process).
- 3) Unplug the electric power leaving the softener control valve in the brine draw cycle.
- 4) Disconnect the brine tube at the top of the brine tank and force air into the brine tube toward the softener mineral tank and control valve. The air will force the brine/water solution that was drawn into the mineral tank out to drain through the control valve drain line. (An air compressor blow gun attachment with a portable air compressor works well.)

CAUTION: You do not want to apply any more pressure than necessary to force the brine/water out of the mineral tank.

The small amount of brine/water that may be left in the mineral tank will not expand enough to cause any damage to the softener when it freezes.

If your softener is equipped with an optional bottom drain on the mineral tank, you will have to follow all of the same procedures with the exception of the need for compressed air. With the brine tube disconnected from the brine tank, raise it to a level above the softener control valve and temporarily secure it in this position. Now open the drain valve at the bottom of the mineral tank and allow all brine/water to drain from the mineral tank.

CAUTION: If a hose is connected to the drain valve to direct the brine/water to a floor drain be sure it runs downward and is unobstructed. When brine/water quits running at the drain, be sure to leave the drain valve open until you start the system up again.

- 5) At this time the brine tank has very little water left in it. What liquid is left in the brine tank is saturated brine, provided there is still salt left in the tank. Saturated brine will not freeze solid and cause any damage and does not have to be drained any further from the brine tank.
If there is no salt left in the brine tank when the system is drained we recommend dumping all of the water out of the brine tank at this time. See brine tank cleaning instructions. (#2 in Miscellaneous section, below)
- 6) **CAUTION:** It is important at this time to be assured that the inlet/outlet water supply piping is properly drained. Depending on how the water supply piping was routed to the water softener control valve, a water loop or trap may have been created.
Sometimes drain valve(s) are installed at the bottom of the loop to assure all water can be drained out. If not it may be necessary to disconnect the control valve from the piping system and open the inlet/outlet valve(s) to allow all the water to drain from the piping. This should be done when the rest of the plumbing system is drained.
- 7) Draining or winterizing of your softener is complete. Refer to the start-up procedures on page 8 when you are ready to start-up your softener.

MISCELLANEOUS

- 1. Salt Usage: See your water conditioning professional for a recommendation on the best type of salt for your application.
- 2. Brine Tank Cleaning:
 - a. Remove brine tank cover.
 - b. Scoop out as much old salt as possible.
 - c. Disconnect brine tubing from safety brine valve at brine well.
 - d. Remove safety brine valve from brine well by placing one hand in brine well to hold overflow nut and remove 2 piece overflow.
 - e. Remove optional brine well and grid plate, if used, from brine tank.
 - f. Remove any remaining salt and/or impurities from brine tank.
 - g. Using clean water and a brush or rag, wipe and rinse inside of brine tank. Also wipe and rinse the grid plate and brine well.
 - h. Reassemble brine tank reversing steps c - e. Note: If grid plate is used and it is damaged or cracked, replace with new one.
 - i. Put brine tank in place making sure there is no debris or foreign material beneath it.
 - j. Reconnect brine tubing to safety brine valve.
 - k. Manually add 6 inches of water to the brine tank (or to approximately 1” above the grid plate, if used).
 - l. Add new salt. Important: Do not add the old salt which was removed earlier unless it is clean and not mushy. We recommend using new salt.
 - m. Follow the disinfection instructions found at the top of this page.
 - n. Put on brine tank cover.

TROUBLE SHOOTING

PROBLEM	CAUSE	CORRECTION
<p>After resolving the cause of any error code or any service work on valve, press NEXT & REGEN simultaneously for 5 seconds or disconnect power supply for 5 seconds at PC board and reconnect to resynchronize software with piston position.</p>		
<p>1. VALVE ERROR CODES</p>		
<p>Error Code 101 - Unable to recognize start of regeneration</p>	<p>A1. Control not reading piston position</p>	<p>A1. Resynchronize software with piston position by pressing start of regeneration NEXT and REGEN buttons simultaneously for 5 seconds, until screen changes. Initiate regeneration to verify function by pressing and holding REGEN button until regeneration initiates, step through regeneration modes by pushing REGEN button each time motor stops.</p> <p>A2. Verify motor connection to PC board; motor wires intact and motor fully inserted to engage pinion.</p> <p>A3. Verify correct assembly; PC board snapped onto drive bracket and wires are in backplate guides and drive bracket snapped onto backplate. Verify three drive gears are in place on drive bracket.</p>
<p>Error Code 102 - Unexpected stall</p>	<p>B1. Mechanical Binding</p> <p>B2. Improper voltage being delivered to board</p>	<p>B1a. Check for any foreign material in stack assembly impeding piston movement and remove; verify seals intact and in place in stack assembly, if not replace stack assembly.</p> <p>B1b. Check for incorrect assembly, drive bracket not snapped into place, motor pushed inside of barrel of drive bracket (black gear on motor end should be flush with end of shaft).</p> <p>B1c. Drive gears unable to rotate freely - replace gear(s) if not rotating freely.</p> <p>B2. Motor unable to move piston, check voltage is present on 12V DC motor at start of regeneration modes. Transformer should provide 12 volts when plugged into outlet and not attached to board - if not replace transformer</p>
<p>Error Code 104 - Motor ran too long, timed out trying to reach home position</p>	<p>C1. Piston unable to reach home position</p>	<p>C1. Incorrect assembly; check drive bracket is correctly seated and snapped into place on backplate, wires outside of guides on backplate can impede drive bracket from correct position.</p> <p>C2. Check PC board is seated on posts and snapped into place on drive bracket</p> <p>C3. Drive gear labels dirty or missing, missing or broken gear, replace as needed</p>
<p>MAV ERROR CODES</p> <p>After resolving any MAV error or servicing MAV, resynchronize software with piston positioning by pressing NEXT and REGEN buttons simultaneously for 5 seconds or disconnecting power from PC board for 5 seconds and reconnecting.</p>		
<p>ALTERNATING MAV DRIVE - ERROR CODES 106 & 107</p>		
<p>Error Code 106 - Alternating MAV ran too long</p>		<p>A1. Control valve is programmed for alternating or as NHWB without having MAV connected to board. Reprogram valve to proper setting or connect MAV to alternating MAV drive on PC board</p> <p>A2. MAV motor not fully engaged with gears</p>
<p>Error Code 107 - Alternating MAV stalled</p>	<p>Mechanical Binding</p>	<p>B1. Open MAV and check for foreign material on stack assembly, remove if present, verify seals intact and in place. If not, replace stack assembly</p> <p>B2. Drive gear should spin freely-replace if necessary</p>
<p>AUXILIARY MAV DRIVE - ERROR CODES 116 & 117</p>		
<p>Error Code 116 - Auxiliary MAV ran too long</p>		<p>A1. Control valve is programmed for auxiliary MAV without having MAV connected to board. Reprogram valve to proper setting or connect MAV to two-pin connection labeled auxiliary drive on PC board</p> <p>A2. MAV motor not fully engaged with gears</p>
<p>Error Code 117 - Auxiliary MAV stalled</p>	<p>Mechanical Binding</p>	<p>B1. Open MAV and check for foreign material on stack assembly, remove if present, verify seals intact and in place. If not, replace stack assembly</p> <p>B2. Drive gear and reducing gears should spin freely, replace if necessary</p>
<p>2. Control valve stalled in regeneration</p>	<p>A. No electric power at outlet</p> <p>B. Motor not operating</p> <p>C. Defective transformer</p> <p>D. Defective PC board</p> <p>E. Broken drive gear or drive cap assembly</p> <p>F. Broken piston retainer</p> <p>G. Broken main or regenerant piston</p>	<p>A. Repair outlet or use working outlet</p> <p>B. Replace Motor</p> <p>C. Replace transformer</p> <p>D. Replace PC board</p> <p>E. Replace drive gear or drive cap assembly</p> <p>F. Replace drive cap assembly</p> <p>G. Replace main or regenerant piston</p>

TROUBLE SHOOTING

PROBLEM	CAUSE	CORRECTION
3. Control valve does not regenerate automatically when REGEN button is depressed and held	<ul style="list-style-type: none"> A. Transformer unplugged B. No electric power at outlet C. Broken drive gear or drive cap assembly D. Defective PC board 	<ul style="list-style-type: none"> A. Connect transformer B. Repair outlet or use working outlet C. Replace drive gear or drive cap assembly D. Replace PC board
4. Control valve does not regenerate automatically but does when REGEN button is depressed	<ul style="list-style-type: none"> A. By-pass valve in bypass position B. Meter connection disconnected C. Restricted/stalled meter turbine D. Defective meter E. Defective PC board F. Set-up error 	<ul style="list-style-type: none"> A. Put control valve in service position B. Connect meter to PC board C. Remove meter and check for rotation or foreign matter D. Replace meter E. Replace PC board F. Check control valve set-up procedure
5. Time of day flashes on and off	<ul style="list-style-type: none"> A. Battery back-up maintains time-of-day in event of power outage and battery is not depleted. Time of day flashes when battery is depleted. 	<ul style="list-style-type: none"> A. Reset time of day and replace battery on PC Board (Lithium coin type battery 2032)
6. Softener delivers hard water.	<ul style="list-style-type: none"> A. Bypass valve is open or faulty. B. No salt or low salt level in brine tank. C. Softener fails to draw brine. D. Excessive water usage. E. Insufficient brine level in brine tank. F. Resin level inadequate. G. Meter faulty. H. Raw water hardness fluctuation. 	<ul style="list-style-type: none"> A. Close bypass valve or replace. B. Add salt to brine tank and maintain salt level above water level. C. See problem #11. D. Check gallon capacity settings. E. Check brine refill setting and refill flow restrictor for blockage. F. See problem #8. G. Test meter and clean or replace meter. H. Test raw water hardness and adjust settings to highest known hardness.
7. Unit uses too much salt.	<ul style="list-style-type: none"> A. Improper brine refill setting. B. Improper settings. C. Excessive water in brine tank. D. Leaking faucets, toilets, etc... 	<ul style="list-style-type: none"> A. Check brine refill setting for proper salt dosage B. Check water hardness and reevaluate capacity setting specification C. See problem #10. D. Repair or replace those items.
8. Loss of resin.	<ul style="list-style-type: none"> A. Backwash controller missing. B. Faulty distributor tube assembly. C. Air in water supply system. 	<ul style="list-style-type: none"> A. Install backwash controller. B. Check distributor tube assembly for cracks or holes. C. <ul style="list-style-type: none"> 1. Check for leaks in brine lines, fittings, or air check. Repair or replace. 2. Install upper distributor. 3. Ensure that water supply system has an air eliminator.
9. Softener delivers salt water.	<ul style="list-style-type: none"> A. Low water pressure. B. Excessive water in brine tank. C. Wrong size injector. 	<ul style="list-style-type: none"> A. Check incoming water pressure—Must remain at minimum of 25psi. B. See problem #11. C. Install correct injector.
10. Excessive water in brine tank.	<ul style="list-style-type: none"> A. Plugged injector. B. Faulty piston assembly. C. Plugged or kinked drain line. D. Backwash flow controller closed off. E. Defective brine line flow control. 	<ul style="list-style-type: none"> A. Remove injector and clean ports. B. Replace piston assembly. C. Inspect drain line for kinks or plugging. D. Check backwash flow controller. E. Replace brine refill flow control.
11. Softener fails to draw brine.	<ul style="list-style-type: none"> A. Injector is plugged. B. Faulty piston assembly. C. Brine line connection leak. D. Drain line plugged creating excess back pressure. E. Drain line too long or too high F. Low inlet pressure. 	<ul style="list-style-type: none"> A. Remove injector and clean ports. B. Check piston assembly. C. Inspect brine line during refill cycle for leaks. D. Inspect drain line for blockage. E. Refer to drain line specifications-Pg 6 Install instructions. F. Increase inlet pressure to a minimum of 25 psi.
12. Continuous flow to drain.	<ul style="list-style-type: none"> A. Piston assembly failure. B. Motor failure. C. Circuit board failure. 	<ul style="list-style-type: none"> A. Replace piston assembly. B. Replace motor. C. Replace circuit board.
13. Loss of water pressure.	<ul style="list-style-type: none"> A. Iron build-up in resin. B. Resin bed fouled with sand or sediment. C. Resin bed mashing due to high amount of oxidizers in water supply (chlorine). 	<ul style="list-style-type: none"> A. See problem #15. B. Rebed softener and install sediment filter ahead of softener. C. Rebed softener. Install dechlorination system ahead of softener.
14. Iron in softened water.	<ul style="list-style-type: none"> A. Iron has fouled resin bed. B. Iron is not in a soluble state. C. Prefilter failure. D. Iron level excessive. E. Control fails to regenerate. 	<ul style="list-style-type: none"> A1. Use iron reducing resin cleaner to cleanse resin bed, and increase salt dosage or regenerate more frequently. A2. Install an Iron Curtain System ahead of the softener. B. Test water to determine type of iron, install iron reduction system. C. Check prefilter. D. Install iron reduction system. E. See problem #4.

TROUBLE SHOOTING

PROBLEM	CAUSE	CORRECTION
15. Control does not display correct	A. Power outage < 2 years, time of day flashing, battery depleted	A. Reset time of day, replace lithium coin type battery on circuit board
16. No "softening" or "filtering" display when water is flowing	A. Bypass valve in bypass position B. Meter connection disconnected C. Restricted/stalled meter turbine D. Defective meter E. Defective PC board	A. Put bypass valve in service position B. Connect meter to PC board C. Remove meter and check for rotation, clean foreign material D. Replace meter E. Replace PC board
17. Control valve regenerates at wrong time of day	A. Power outages/battery depleted B. Time of day not set correctly C. Time of regeneration incorrect D. Control valve set at "immediate" E. Control valve set at Delay + Immediate	A. Reset control valve to correct time of day, replace battery B. Reset to correct time of day C. Reset regeneration time D. Check control valve set-up procedure, regeneration time option (see programming options, page 11-softener setup) E. Check control valve set-up procedure regeneration time option (see programming options, page 11-softener setup)
18. LED display is blank	A. Transformer unplugged B. No electric power at outlet C. Defective transformer D. Short in meter E. Defective circuit board	A. Plug transformer into outlet that cannot be switched off B. Repair outlet or use working outlet C. Replace transformer D. Remove control cover, plug control into power supply, unplug meter from PC board. If LED display lights up, replace meter. Short in meter cable may cause partial or blank display of LED E. Replace circuit board after all of the above steps have been addressed

RELAY TROUBLESHOOTING

PROBLEM	CAUSE	CORRECTION
19. Relay does not energize		
A. Relay driver programmed on "Time"	A. Programmed incorrectly B. Defective relay, See figure below C. Defective PC Board D. Faulty wire connections between PC board and relay	A. Reprogram, see page 12 B. Replace Relay C. Replace PC Board D. Check and repair wire connections
B. Relay driver programmed on "Gallons"	A. Programmed incorrectly B. Faulty meter connection C. Defective relay, See figure below D. Defective PC Board E. Faulty wire connections between PC board and relay	A. Reprogram, see page 12 B. Repair or replace meter assembly C. Replace Relay D. Replace PC Board E. Check and repair wire connections

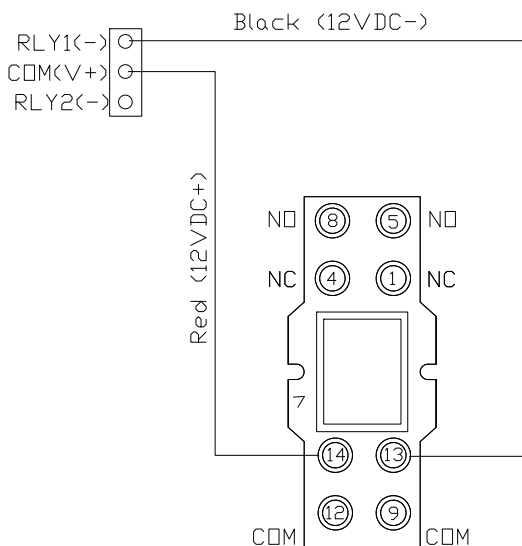

Relay operation while in error modes

1. Relays should turn off immediately whenever a Valve Error occurs.
2. Relays should remain on and continue to operate as programmed if a MAV Error (106/107 or 116/117) occurs and the valve has already entered regeneration.
3. Relays should remain off, and not operate as programmed, if a MAV Error (106/107 or 116/117) occurs and the valve has not entered regeneration.

H151 HE CONDITIONER & BRINE TANK ASSEMBLIES

Item	Description	Qty	Part #
1	Control Center Metered	1	111215
2	Upper Baffle Diffuser 4" Top Tank	1	101489

Items required with 6" top flanged tanks

2A	Top Diffuser 6" Flanged Top Tank	1	101490
2B	Screw Diffuser Retaining	2	102461
2C	Adapter Kit 6x4	1	100316

3&4	Mineral Tank Assembly		Tank (diameterxheight)	Tank Only#	Dist Only #
	H151-HE 14	1	14x65	104581	103517
	H151-HE 16	1	16x65	104583	103518
	H151-HE 18	1	18x65	104585	103519
	H151-HE 21	1	21x62	104388	103519

5	Ion Exchange Resin	*	111102	Hellenbrand High Efficiency Resin
6	Underbedding #20 Flint	*	100983	
7	1/2" Brine line	1	102674	
8-15	24x41 3/8" 474 SBV & No Grid	1	106510	
	24x50 1/2" 474 SBV & 6" Grid	1	104430	
8	24x41 Brine Tank Only-Black	1	104495	
	24x50 Brine Tank Only-Black	1	104497	
9	Cover Black 24" BT	1	2-G2194	
10	Cap, Brine Well 4"	2	101365	
11	Safety Brine Valve 474-.5 (Must be ordered complete)	1	101275	
12	Float Assembly	1	101660	
13	Air Check	1	101181	
14	Brine Well 40-41"	1	102877	
	Brine Well 50"	1	102878	
15	2-Piece Overflow	1	102217	
Not Shown	Tee for twin units w/one brine tank	1	103661	
Not Shown	Owners Manual	1	800683	

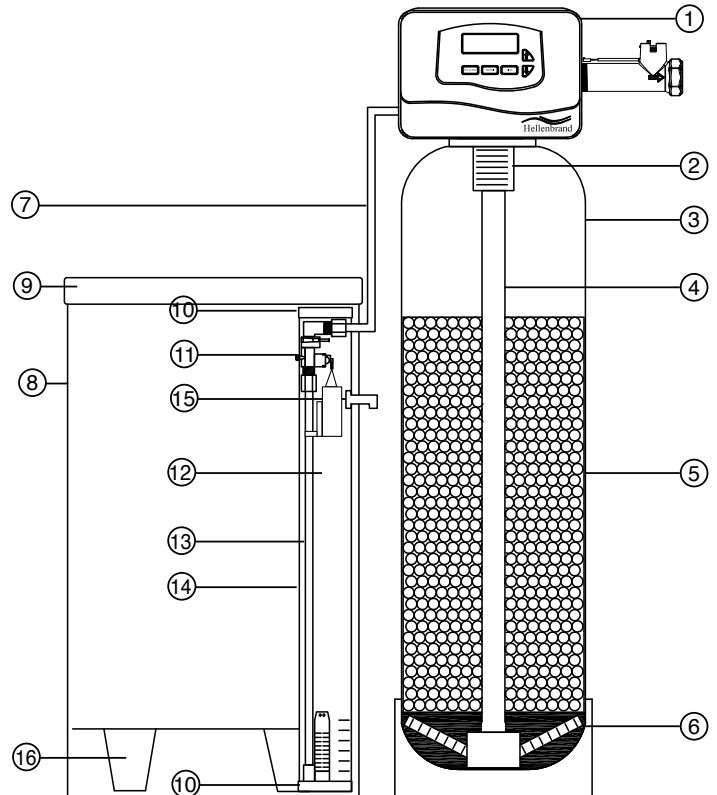
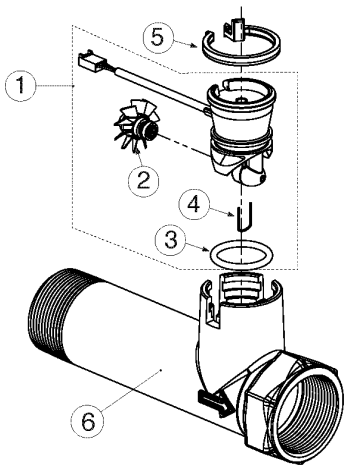

Figure 13

INLINE FLOW METERS

1.5" Meter Assembly p/n 102049

DRAWING NO.	ORDER NO.	DESCRIPTION
1	102075	Remote Meter Assembly
2	V3118-03	Turbine Assembly
3	102165	O'Ring-215
4	109587	Turbine Clip
5	105967	Meter Retaining Clip
6	101784	1.5" Meter Housing



1.5" Meter Assembly

- Lead free brass construction
- Service flow range 0.5-60 gpm
- Meter accuracy $\pm 5\%$
- 15-foot cable included
- 1-1/2" male x female pipe NPT

1.0" Meter Assembly, Less Fittings p/n 108566

DRAWING NO.	ORDER NO.	DESCRIPTION
1	102075	Remote Meter Assembly
2	109586	Turbine Assembly
3	102165	O'Ring-215
4	109587	Turbine Clip
5	V3755	1" Remote Meter Housing
6	102141	1" Nut

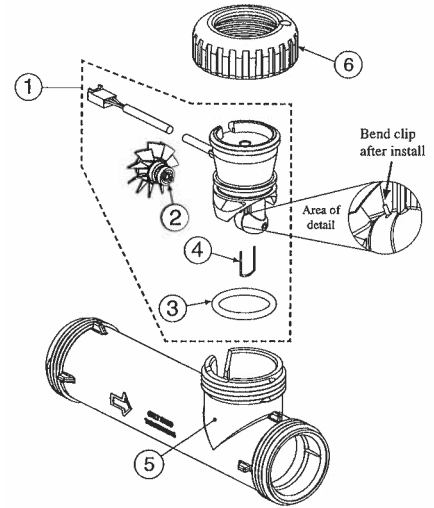

1.0" Meter Assembly

- Noryl plastic construction
- Service flow range 0.5-40 gpm
- Meter accuracy $\pm 5\%$
- 15-foot cable included

FRONT COVER AND DRIVE ASSEMBLY

DRAWING NO.	ORDER NO.	DESCRIPTION	QUANTITY
1	109582	Front Cover Assembly Black	1
2	102096	Motor Assembly	1
3	101262	Drive Bracket & Spring Clip	1
4	109807	PC Board	1
5	101746	Drive Gear 12x36	3
6	101459	Drive Gear Cover	1
7	Relay Kit Options:		1
	103724	PCM Relay Installed	
	103723	PCM Relay Kit	
	103730	Pigtail Relay Installed	
	103729	Pigtail Relay Kit	
Not Shown	101880	Auxiliary Switch Kit	1
Not Shown	102892	Service Wrench	1
Not Shown	102653	Transformer 110V-12V	1

Relay Specifications: To insure proper fit and correct operation the following relay and relay socket manufactured by Idec or the exact equivalent should be used.

	RELAY MODEL AND DESCRIPTION
Relay Socket	102533 (2 pole mount socket)
Relay	102385 (12V DC DP magnetic relay)

The relay supplies 2 sets of dry contacts for user applications. The wiring of these contacts is application specific.

WIRING FOR CORRECT ON/OFF OPERATION	
PC Board Relay Terminal Block	Relay Socket Terminal #
RLY1 / -	#13
Com / V+	#14
RLY2 / -	

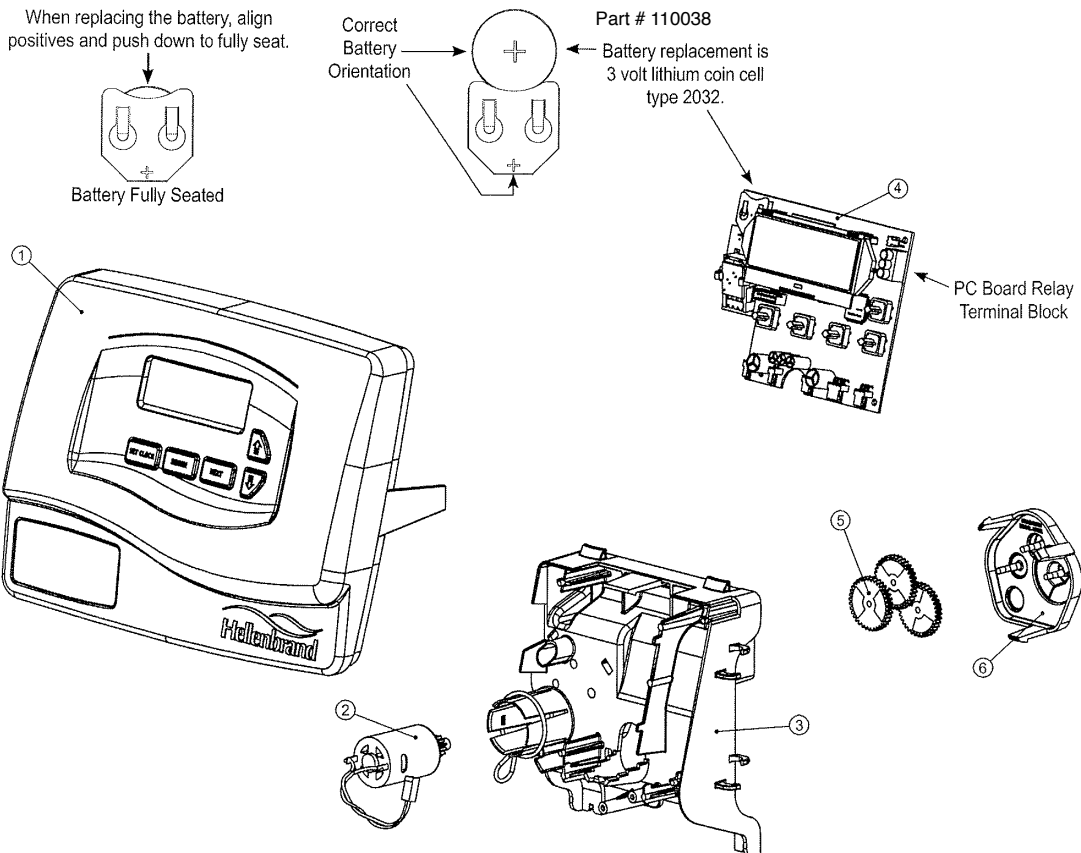
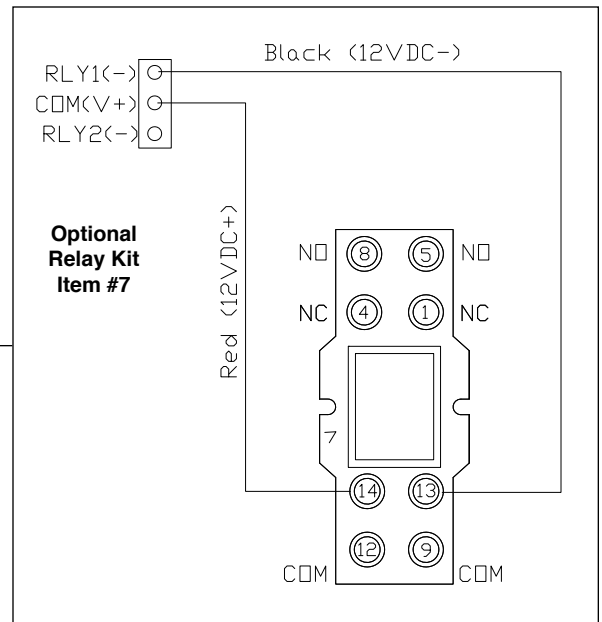

DRIVE CAP ASSEMBLY, DOWN FLOW PISTON, REGENERANT PISTON AND SPACER STACK ASSEMBLY

DRAWING NO.	ORDER NO.	DESCRIPTION	QUANTITY
1	101613	H151 HE Drive Cap Assembly	1
2	102167	O-Ring 228	1
3	111283	H151 HE Piston Upflow Assy	1
4	102296*	H151 HE Regenerant Piston	1
5	101609	H151 HE Backplate Dowel	1
6	102547	H151 HE Spacer Stack Assy	1
7	101189	Back Plate	1
8	102184	O-Ring 347	1
9	108620	O-Ring 328 for Valve Bodies w/NPT Threads	1
10	109528	H151 HE NPT Valve Body, Gen 2	1
11	109529	Test Port Plug, 1/4" NPT	2
12	101489	Top Baffle Diffuser, 1.5/50MM	1

*102296 regenerant piston not used for backwash only valves. 102318 injector plug and 102322 refill port assembly plugs must be used for backwash only valves.
NPT threads on drain port.

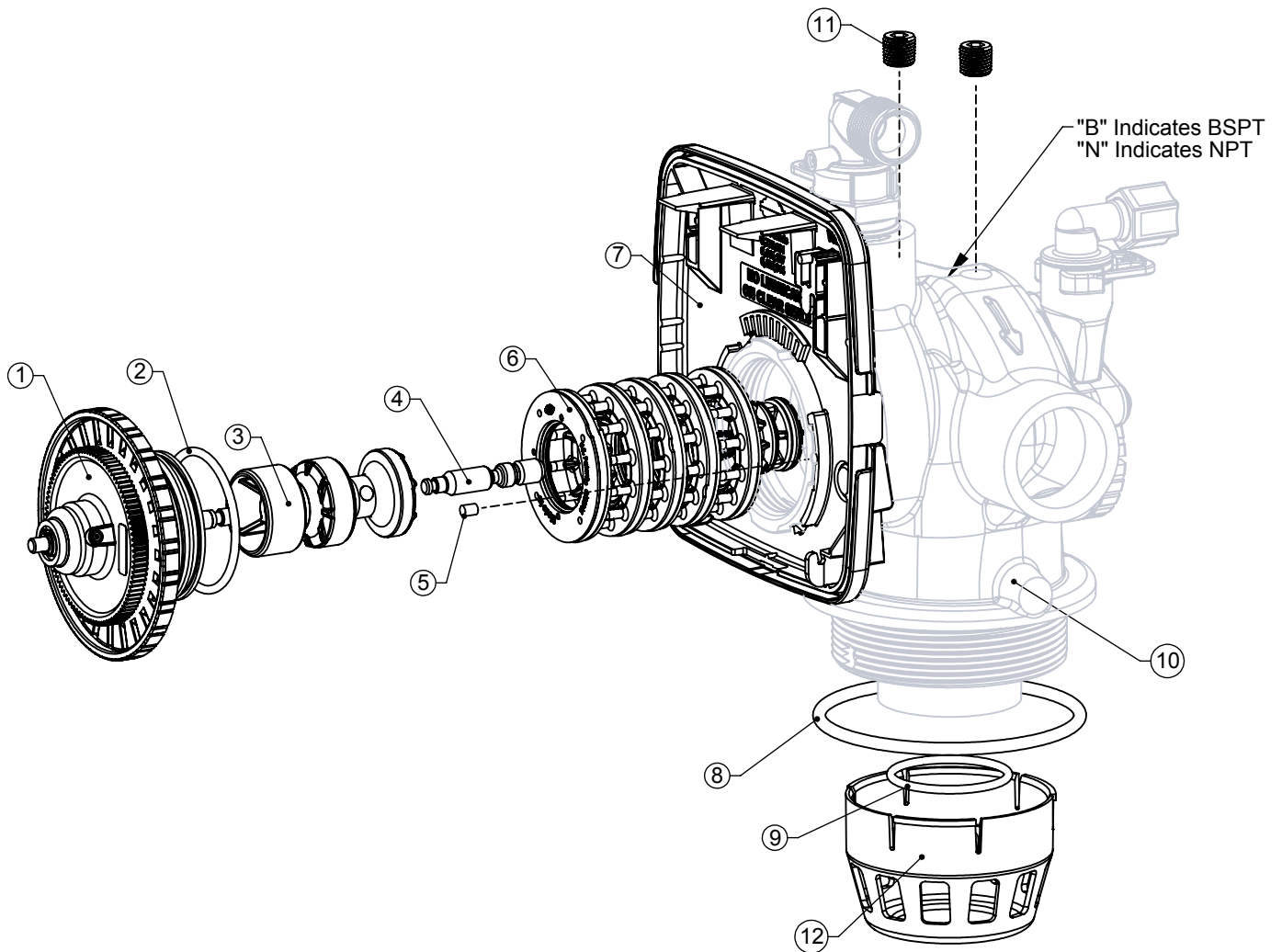

REGENERANT BODY

ITEM NO.	ORDER NO.	DESCRIPTION	QTY
1	109530	H151 HE Injector Body, Welded Assy	1
2	109531	O-Ring-226	1
3	111320	H151 HE Injector Feed Tube	1
4	102457	H151 HE Injector Screen	1
5	111321	H151 HE Injector Draw Tube	1
6	101375	H151 HE Injector Cap	1
7	102159	O-Ring-135	1
8	See Chart	H151 HE 1-1/2" Injector	1
	101811	C - Red	
	101812	D - White	
	101813	E - Blue	
	101814	F - Yellow	
	101815	G - Green	
	101816	H - Orange	
	TBD	I - TBD	
9	103588	Refill Flow Control, 1/2"	1
10	102417	H151 HE Refill Retainer Assy (0.5GPM)	1
11	102153	O-Ring-019	1
12	H4612	Elbow Cap, 1/2" (See #9)	1
13	102129	Nut, Compression, 1/2" Black (See #9)	1
14	101869	Insert, Polytube 1/2" (See #9)	1
15	102421	Refill Flow Control	1
16	101414	Retaining Clip	1
17	109534	Washer, Flat Stainless Steel	4
18	109535	Bolt, Stainless Steel 1/4-20x1-1/4	4
19	102322	Refill Plug Port	1
	102318	Plug - Black	1

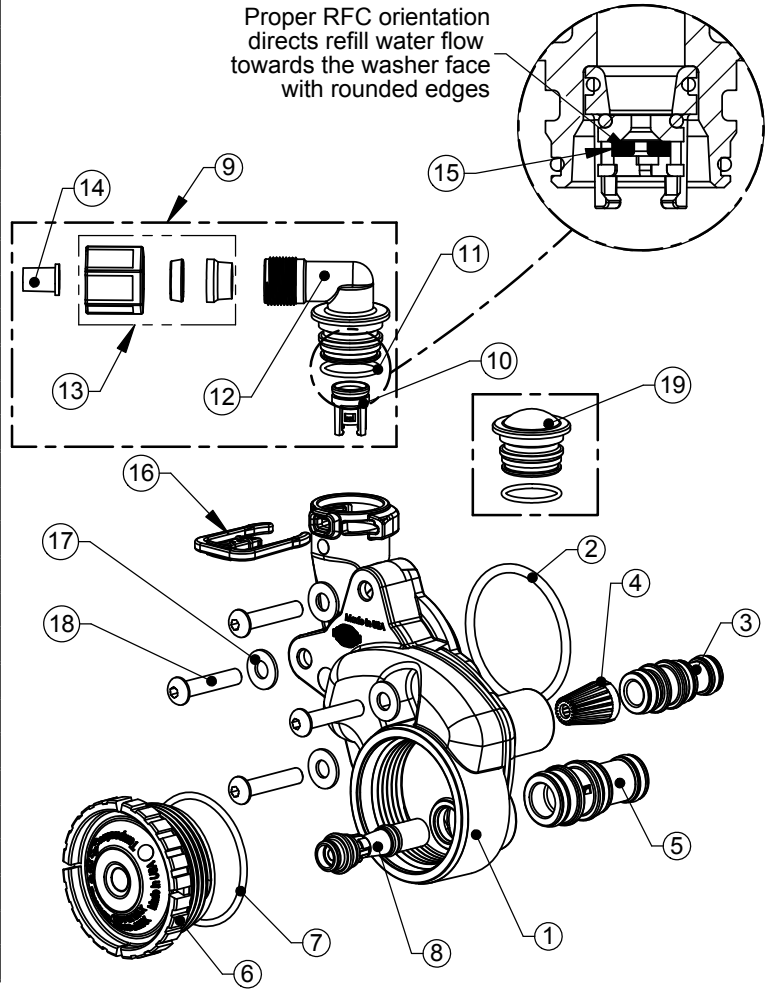

A 109532 Injector Feed Tube Assembly contains one O-ring-111 and two O-rings-112's.

An Injector Draw Tube Assembly contains one O-ring-113 and two O-rings-115's.

DRAIN LINE - 3/4"

ITEM NO.	ORDER NO.	DESCRIPTION	QTY.
1	101414	Locking Clip	1
2	101159	H151 HE DLFC Adapter	1
3	101618	H151 HE Drain Elbow 3/4"	1
4	102153	O-ring 019	1
5	102406	DLFC Retainer Assy	1
6	101583	DLFC 3.2 gpm for 3/4"	One DLFC must be used if 3/4" fitting is used
	101588	DLFC 4.2 gpm for 3/4"	
	101591	DLFC 5.3 gpm for 3/4"	
	101593	DLFC 6.5 gpm for 3/4"	
	101595	DLFC 7.5 gpm for 3/4"	
	101598	DLFC 9.0 gpm for 3/4"	
	101561	DLFC 10.0 gpm for 3/4"	

Valves are shipped without drain line flow control (DLFC) - install DLFC before using. Use a minimum drain line size of 3/4".

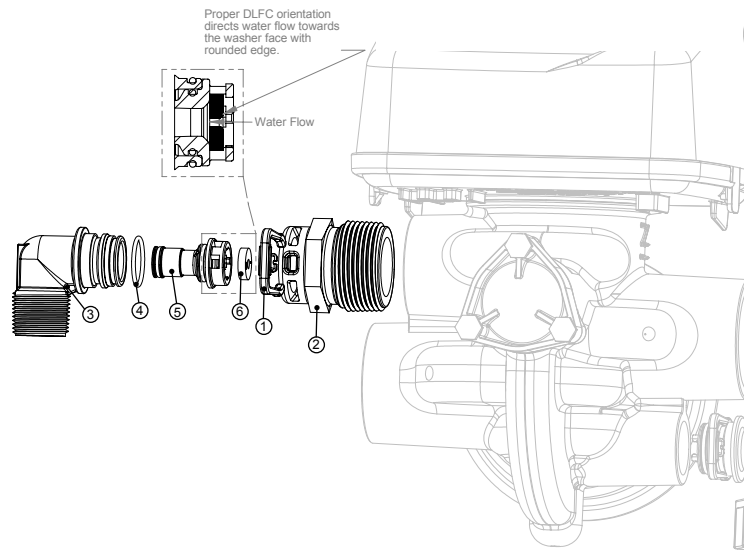

Figure 18

DRAIN LINE - 1"

ITEM NO.	ORDER NO.	DESCRIPTION	QTY.
1	101414	Locking Clip	1
2	101159	H151 HE DLFC Adapter	1
3	101635	Drain Ftg Body, 1" Straight	1
4*	102153	O-ring 019	1
5*	101160	Drain Ftg Adapter, 1"	1
6*	102141	Nut, 1" QC	1
7*	102437	Split Ring	1
8*	102165	O-ring 215	1
9*	101244	Drain Ftg Body 1"	
10	101599	DLFC 9.0 gpm for 1"	One DLFC must be used if 1" fitting is used
	101562	DLFC 10.0 gpm for 1"	
	101564	DLFC 11.0 gpm for 1"	
	101567	DLFC 13.0 gpm for 1"	
	101568	DLFC 15.0 gpm for 1"	
	101571	DLFC 17.0 gpm for 1"	
	101578	DLFC 20.0 gpm for 1"	
	101580	DLFC 25.0 gpm for 1"	

*Can be ordered as a set, order number 101635 Drain Fitting 1" Straight.

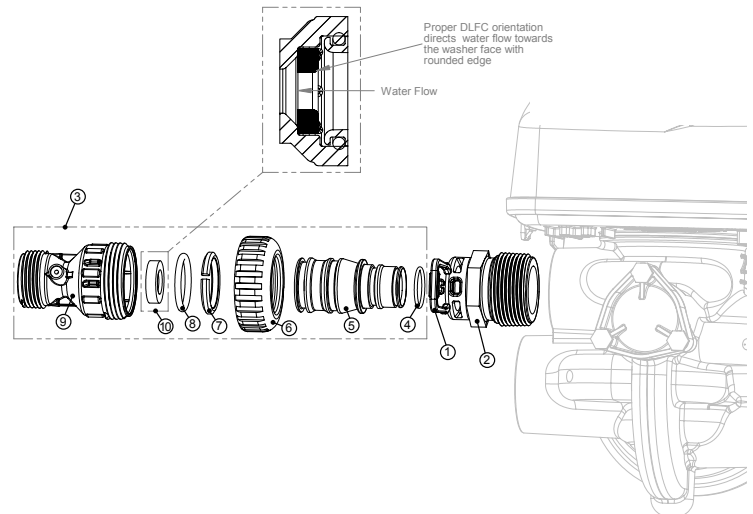
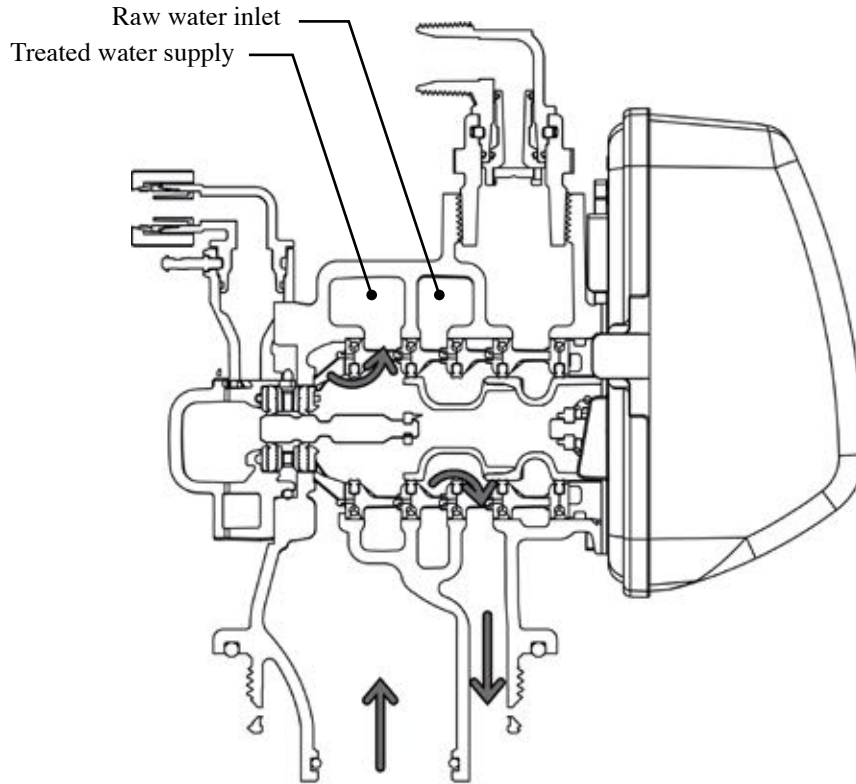
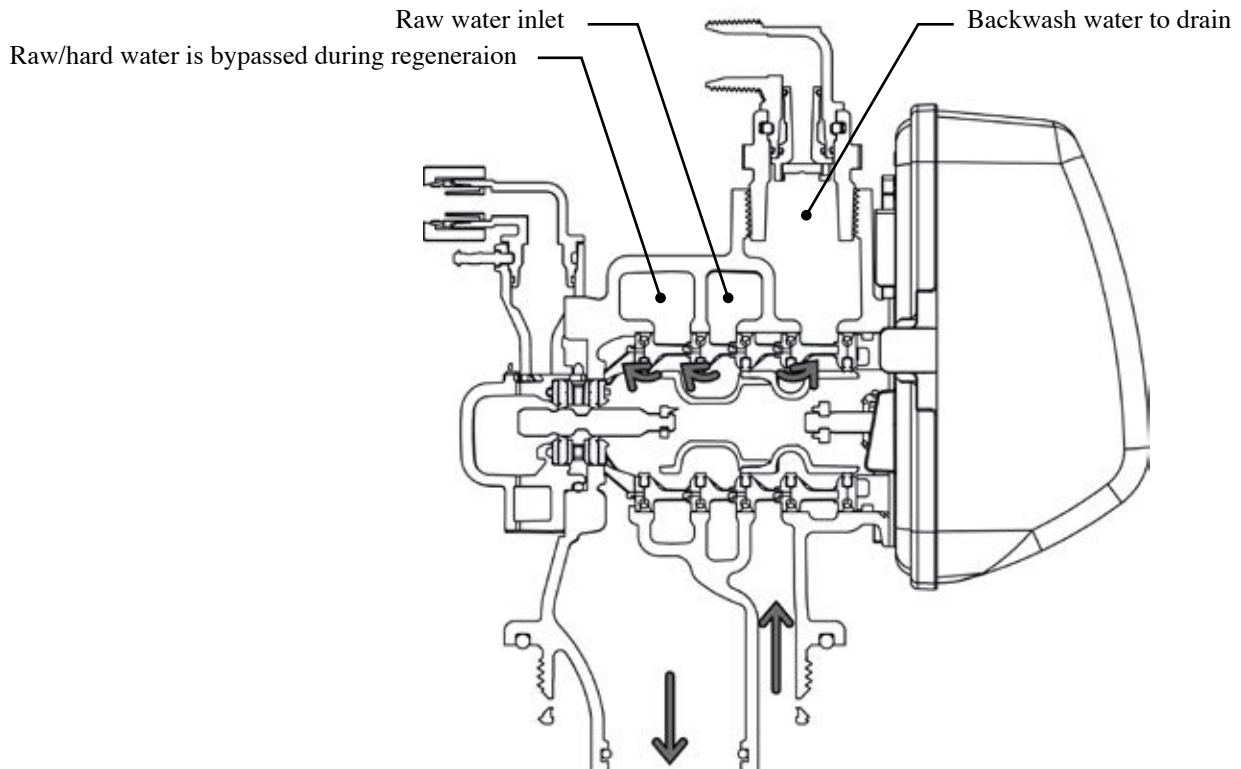

Figure 19

CONTROL VALVE CYCLE POSITION – SERVICE



CONTROL VALVE CYCLE POSITION – BACKWASH



CONTROL VALVE CYCLE POSITION – UPFLOW BRINE

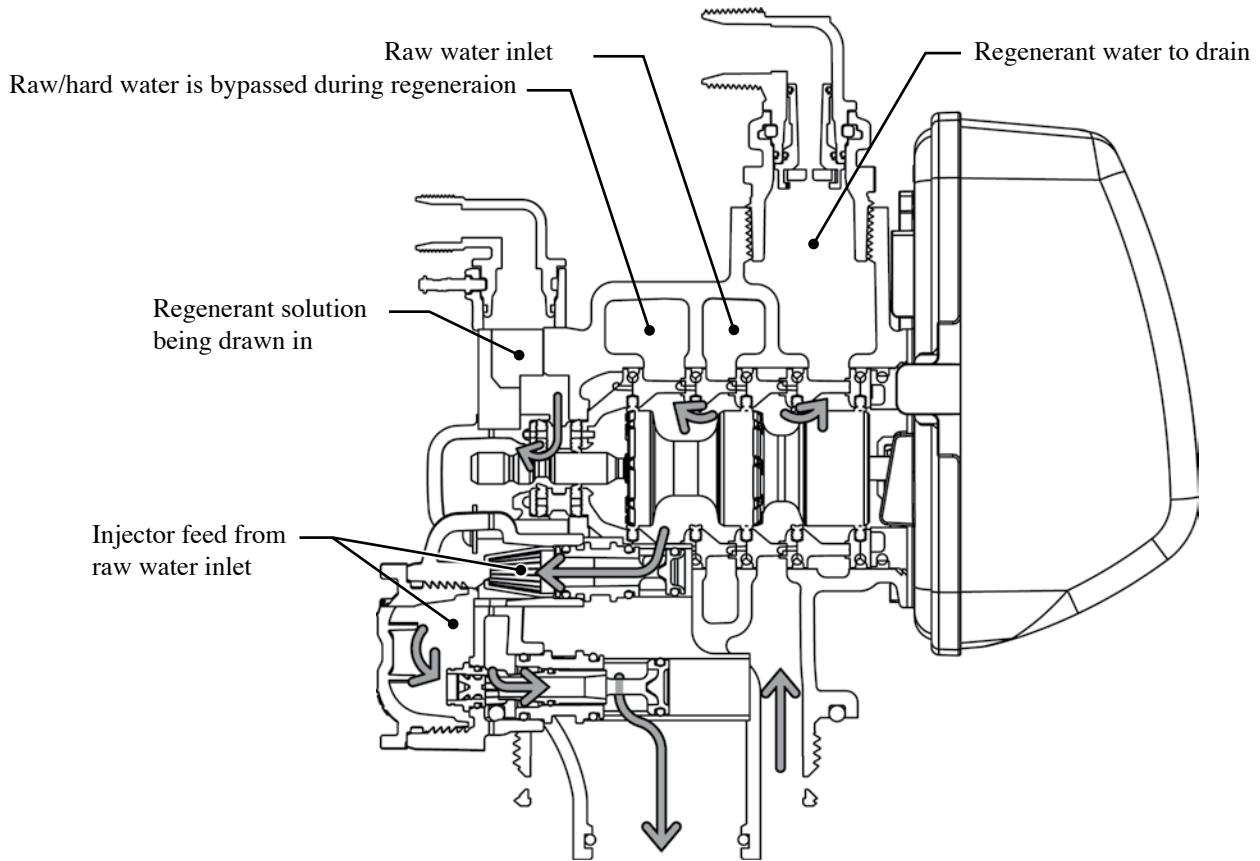

CONTROL VALVE CYCLE POSITION – RINSE

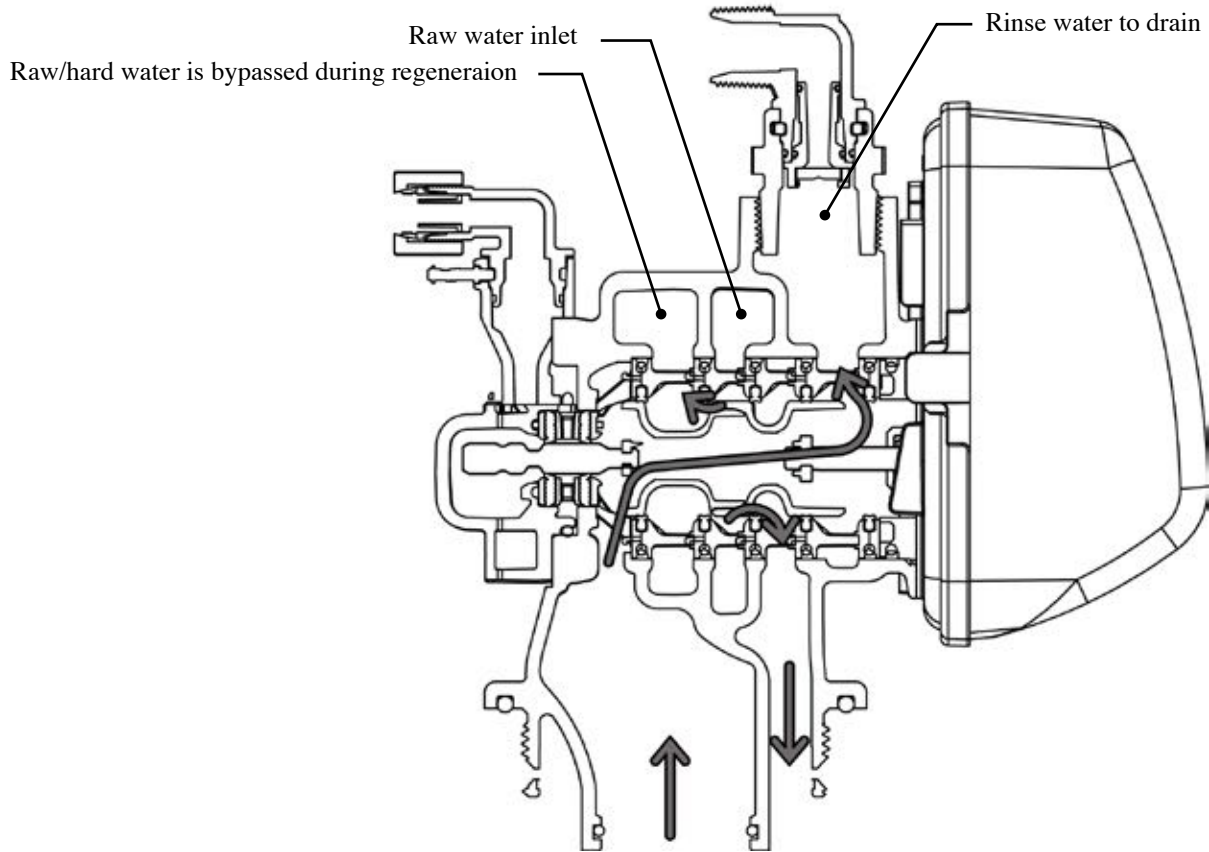



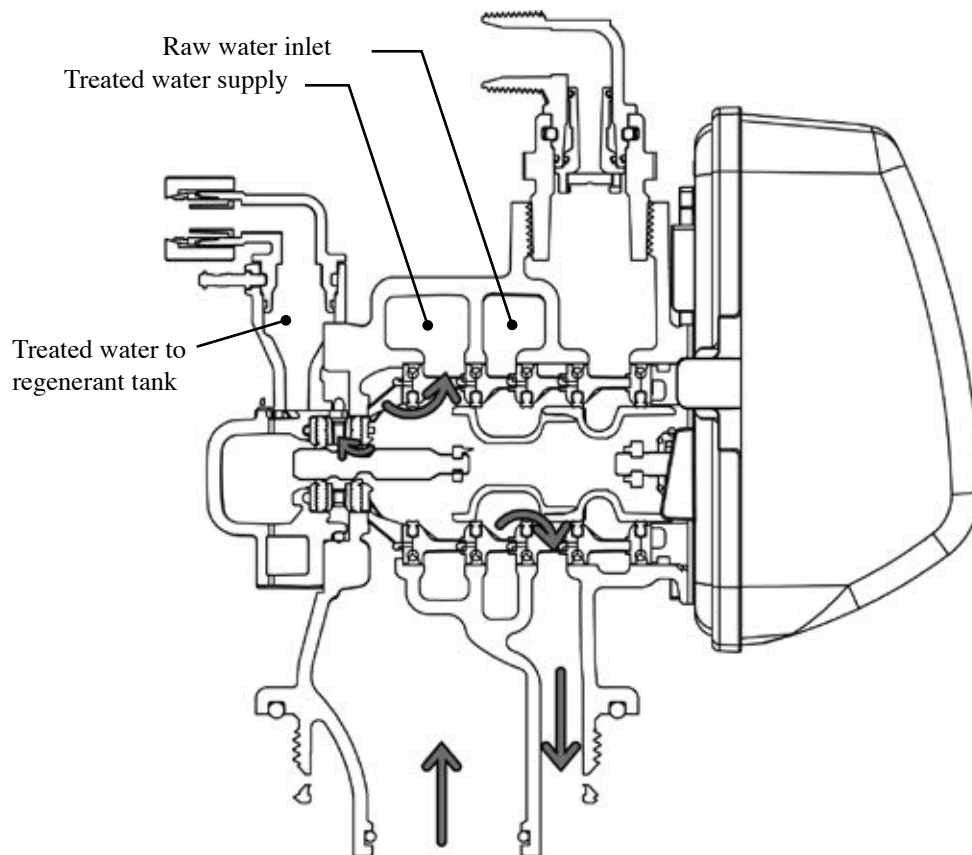

TREATED WATER REFILL



PROGRAMMING OPTIONS

Reserve Gallons	Regeneration Type	Days Override	Results (Reserve capacity estimate based on history of water usage)
AUTO	Delay	oFF	Reserve capacity automatically estimated. Regeneration occurs when gallons capacity falls below the reserve capacity at the next Regen Set Time.
AUTO	Delay	1 to 28	Reserve capacity automatically estimated. Regeneration occurs at the next Regen Set Time when gallons capacity falls below the reserve capacity or the specified number of days between regenerations is reached.
20 to 250,000	Delay	oFF	Reserve capacity <u>not</u> automatically estimated. Regeneration occurs at the next Regen Set Time when gallons capacity reaches 0.
oFF	Delay	1 to 28	Reserve capacity <u>not</u> automatically estimated. Regeneration occurs at the next Regen Set Time when the specified number of days between regenerations is reached.
20 to 250,000	Delay	1 to 28	Reserve capacity <u>not</u> automatically estimated. Regeneration occurs at the next Regen Set Time when gallons capacity reaches 0 or the specified number of days between regenerations is reached.
AUTO	Immediate	oFF	Reserve capacity <u>not</u> automatically estimated. Regeneration occurs immediately when gallons capacity reaches 0. Time of regeneration will not be allowed to be set because regeneration will always occur when gallons capacity reaches 0.
20 to 250,000	Immediate	oFF	Reserve capacity <u>not</u> automatically estimated. Regeneration occurs immediately when gallons capacity reaches 0. Time of regeneration will not be allowed to be set because regeneration will always occur on 0.
AUTO	Delay + Immediate	oFF	Reserve capacity automatically estimated. Regeneration occurs when gallons capacity falls below the reserve capacity at the next Regen Set Time or regeneration occurs immediately after 10 minutes of no water usage when gallon capacity reaches 0.
AUTO*	Delay + Immediate	1 to 28 *14	Reserve capacity automatically estimated. Regeneration occurs at the next Regen Set Time when gallons capacity falls below the reserve capacity or the specified number of days between regenerations is reached or regeneration occurs immediately after 10 minutes of no water usage when gallon capacity reaches 0.
20 to 250,000	Delay + Immediate	1 to 28	Reserve capacity <u>not</u> automatically estimated. Regeneration occurs at the next Regen Set Time when specified number of days between regenerations is reached or regeneration occurs immediately after 10 minutes of no water usage when gallon capacity reaches 0.

***Factory settings in bold**

To "lockout" access to modification settings, diagnostic and valve history displays except hardness, day override and time, press  next,  and clock in sequence to "unlock" press  next,  and clock in sequence.

GENERAL SPECIFICATIONS

OPERATING PRESSURES

Minimum/Maximum25 psi-125 psi

OPERATING TEMPERATURES

Minimum/Maximum40° - 110° F

1-1/2" METER

Accuracy.....±5%
Flow Rate Range.....0.5 - 60 GPM
Gallon Range500 - 250,000

DIMENSIONS

Drain Line3/4" or 1" NPT
Brine Line1/2" Poly Tube

ELECTRICAL CURRENT DRAW AND VOLTAGE.....0.5A 110v

Compatible with the following regenerants or chemicals: Sodium chloride, potassium permanganate, sodium bisulfite, sodium hydroxide, hydroxide, hydrochloric acid, chlorine and chloramines.

SERVICE INSTRUCTIONS

Drive Assembly

Remove the valve cover to access the drive assembly.

Disconnect the power source plug (black wire) from the PC board prior to disconnecting the motor or water meter plugs from the PC board. The power source plug connects to the four-pin jack. The motor plug connects to the two-pin jack on the left-hand side of the PC board. The water meter plug (gray wire) connects to the three-pin jack on the far right-hand side of the PC board.

PC Board Replacement

The PC board can be removed separately from the drive bracket but it is not recommended. Do not attempt to remove the display panel from the PC board. Handle the board by the edges. To remove the PC board from the drive bracket, unplug the power, water meter and motor plugs from the PC board. Lift the middle latch along the top of the drive bracket while pulling outward on the top of the PC board. The drive bracket has two plastic pins that fit into the holes on the lower edge of the PC board. Once the PC board is tilted about 45° from the drive bracket it can be lifted off of these pins. To reinstall a board, push the top of the PC board towards the valve until it snaps under the middle latch, weave the power and water meter wires into the holders and reconnect the motor, water meter and power plugs.

Drive Bracket Replacement

The drive bracket must be removed to access the drive cap assembly and pistons or the drive gear cover. It is not necessary to remove the PC board from the drive bracket to remove the drive bracket. To remove the drive bracket start by removing the plugs for the power source and the water meter. Unweave the wires from the side holders. Two tabs on the top of the drive back plate hold the drive bracket in place. Simultaneously lift the two tabs and gently ease the top of the drive bracket forward. The lower edge of the drive bracket has two notches that rest on the drive back plate. Lift up and outward on the drive bracket to disengage the notches.

To reassemble, seat the bottom of the drive bracket so the notches are engaged at the bottom of the drive back plate. Push the top of the drive bracket toward the two latches. The drive bracket may have to be lifted slightly to let the threaded piston rod pass through the hole in the drive bracket. Maintain a slight engaging force on top of the drive bracket while deflecting the bracket slightly to the left by pressing on the side of the upper right corner. This helps the drive gears mesh with the drive cap assembly. The drive bracket is properly seated when it snaps under the latches on the drive back plate. If resistance is felt before latching, then notches are not fully engaged, the piston rod is not in hold, the wires are jammed between the drive bracket and drive back plate, or the gear is not engaging the drive cap assembly.

Drive Gear Replacement

To inspect the drive gears, the drive gear cover needs to be removed. Before trying to remove the gear cover, the drive bracket must be removed from the drive back plate. (Refer to the instructions above regarding removing the drive bracket from the drive back plate. The drive gear cover can be removed from the drive bracket without removing the motor or the PC board.) The drive gear cover is held in place on the drive bracket by three clips. The largest of the three clips is always orientated to the bottom of the drive bracket. With the PC board facing up, push in and down on the large clip on the drive gear cover. Handle the cover and the gears carefully so that the gears do not fall off the pegs in the cover.

Replace broken or damaged drive gears. Do not lubricate any of the gears. Avoid getting any foreign matter on the reflective coating because dirt or oils may interfere with pulse counting.

The drive gear cover only fits on one way, with the large clip orientated towards the bottom. If all three clips are outside of the gear shroud on the drive bracket the drive gear cover slips easily into place.

Drive Motor Replacement

The drive bracket does not need to be removed from the drive plate if the motor needs to be removed. To remove the motor, disconnect the power and motor plugs from the jacks on the PC board. Move the spring clip loop to the right and hold. Rotate the motor at least a 1/4 turn in either direction so the wires are vertical (up & down) before gently pulling on the wire connectors to remove the motor. Pulling directly on the wires without rotating the motor may break the wires off the motor.

Replace the motor if necessary. Do not lubricate the motor or the gears. To reinstall the motor, move the spring clip loop to the right and hold. Gently turn the motor while inserting so that the gear on the motor meshes with the gears under the drive gear cover. Release the spring clip loop and continue to rotate the motor until the wires are horizontal and the motor housing engages the small plastic bulge inside the drive bracket motor retainer. Reconnect the motor plug to the two-pronged jack on the lower left side of the PC board. If the motor will not easily engage with the drive gears when reinstalling, lift and slightly rotate the motor before reinserting. Reconnect the power plug.

Replace the valve cover. After completing any valve maintenance, press and hold NEXT and REGEN buttons for 3 seconds or unplug power source jack (black wire) and plug back in. This resets the electronics and establishes the service piston position. The display should flash all wording, then flash the software version and then reset the valve to the service position.

Drive Cap Assembly, Main Piston and Regenerant Piston

The drive assembly must be removed to access the drive cap assembly. The drive cap assembly must be removed to access the piston(s). The drive cap assembly is threaded into the control valve body and seals with an o-ring. To remove the drive cap assembly use the special plastic wrench or insert a 1/4" to 1/2" flat blade screwdriver into one of the slots around the top 2" of the drive cap assembly so it engages the notches molded into the drive back plate around the top 2" of the piston cavity. See Figure 29. The notches are visible through the holes. Lever the screwdriver so the drive cap assembly turns counter clockwise. Once loosened, unscrew the drive cap assembly by hand and pull straight out.

The drive cap assembly contains the drive cap, the main drive gear, drive cap, piston rod and various other parts that should not be disassembled in the field. The only replaceable part on the drive cap assembly is the o-ring. Attached to the drive cap assembly is the main piston and if a regenerant is used, a regenerant piston.

The regenerant piston (the small diameter one behind the main piston) is removed from the main piston by pressing sideways and unsnapping it from its latch. Chemically clean this in dilute sodium bisulfite or vinegar, or replace the regenerant piston if needed. To remove the main downflow or upflow piston fully extend the piston rod and then unsnap the main piston, from its latch by pressing on the side with the number. Chemically clean this in dilute sodium bisulfite or vinegar, or replace the main piston.

Reattach the main piston to the drive cap assembly. Reattach the regenerant piston (if needed) to the main piston. Do not lubricate the piston rod, main piston or regenerant piston. Lubricant will adversely affect the clear lip seals. Reinsert the drive cap assembly and piston into the spacer stack assembly and hand tighten the drive cap assembly. Continue to tighten the drive cap assembly using a screwdriver as a ratchet until the black o-ring on the spacer stack assembly is no longer visible through the drain port. Excessive force can break the notches molded into the drive back plate. Make certain that the main drive gear still turns freely. The exact position of the piston is not important as long as the main drive gear turns freely.

Reattach the drive assembly to the control valve and connect all plugs. After completing any valve maintenance, press and hold NEXT and REGEN buttons for 3 seconds or unplug power source jack (black wire) and plug back in. This resets the electronics and establishes the service piston position. This display should flash all wording, then flash the software version and then reset the valve to the service position.

Spacer Stack Assembly

To access the spacer stack assembly remove the drive assembly, drive cap assembly and piston. The spacer stack assembly can be removed easily without tools by using thumb and forefinger. Inspect the black o-rings and clear lip seals for wear or damage. Replace the entire stack if necessary. Do not disassemble the stack.

The spacer stack assembly may be chemically cleaned (dilute sodium bisulfite or vinegar) or wiped with a soft cloth.

The spacer stack assembly can be pushed in to the control valve body bore by hand. Since the spacer stack assembly can be compressed it is easier to use a blunt object (5/8" to 1-1/8" in diameter) to push the center of the assembly into the control valve body. The assembly is properly seated when at least four threads are exposed (approximately 5/8"). Do not force the spacer stack assembly in. The control valve body bore interior can be lubricated with silicone to allow for easy insertion of the entire stack. Do not use silicone or any other type of lubricant on the clear lip seals or the piston.

Reattach the drive cap assembly and the piston(s) and the drive assembly.

After completing any valve maintenance, press and hold NEXT and REGEN buttons for 3 seconds or unplug power source jack (black wire) and plug back in. This resets the electronics and establishes the service piston position. The display should flash all wording, then flash the software version and then reset the valve to the service position.

Injector Cap, Screen, Injector Plug and Injector Replacement

Unbolt the injector cap and lift off. Remove the screen and clean if fouled.

The injector can be pried out with a small screwdriver. The injector consists of a throat and a nozzle. Chemically clean the injector with vinegar or sodium bisulfite. The holes can be blown out with air. Both pieces have smaller diameter holes that control the flow rates of water to insure that the proper concentration of regenerant is used. Sharp objects, which can score the plastic, should not be used to clean the injector. Scoring the injector or increasing the diameter of the hole could change the operating parameters of the injector.

Refill Flow Control Assembly or Refill Port Plug

To clean or replace the refill flow control, pull out the elbow-locking clip and then pull straight up on the elbow. Replace the elbow locking clip

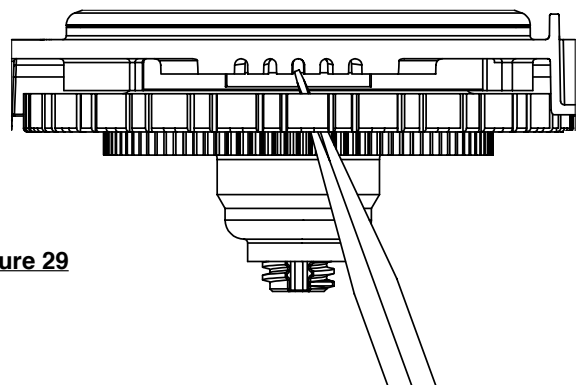

Figure 29

in the slot so that it is not misplaced. Twist to remove the white flow control retainer. The flow control can be removed by prying upward through the side slots of the retainer with a small flat blade screwdriver.

Chemically clean the flow control or the white flow control retainer using dilute sodium bisulfite or vinegar. Do not use a wire brush. If necessary, replace the flow control, o-ring on the flow control retainer, or the o-ring on the elbow.

Reseat the flow control so the rounded end is visible in the flow control. Reseat the white flow control retainer by pushing the retainer into the elbow until the o-ring seats. Remove locking clip, push down on elbow to reseal and insert locking clip.

Do not use Vaseline, oils, or other unacceptable lubricants on o-rings. A silicone lubricant may be used on the o-ring on the elbow or the white retainer.

Water Meter or Meter Plug

The water meter assembly is connected to the PC board by a wire. If the entire water meter assembly is to be replaced, remove the control valve cover and disconnect the power source and water meter plugs from the PC board. Unlatch the drive assembly and lean it in forward. Unthread the water meter wire from the side of the drive assembly and through the drive back plate. To reinstall, rethread the water meter through the drive back plate and side of the drive assembly. Reattach the drive assembly and the water meter and power plugs.

The water meter wire does not need to be removed from the PC board if the water meter is only being inspected and cleaned. To remove the water meter assembly, unscrew the meter cap. Pliers may be used to unscrew the nut if necessary.

With the nut removed, a slot at the top of the water meter is visible. Twist a flat blade screwdriver in the slot between the valve body and the meter. When the meter is part way out it is easy to remove the water meter from the housing. Once the water meter is removed from the body, gently pull forward on the turbine to remove it from the shaft.

Do not use a wire brush to clean the turbine. Wipe with a clean cloth or chemically clean in dilute sodium bisulfite or vinegar. The turbine can be immersed in the chemical. Do not immerse electronics. If the turbine is scored or damaged or the bearings on the turbine are worn, replace the turbine.

Do not lubricate the turbine shaft. The turbine shaft bearings are pre-lubricated. Do not use Vaseline, oils, or other unacceptable lubricants on the o-ring. A silicone lubricant may be used on the black o-ring.

Snap the turbine on the shaft and reinsert the water meter into the slot. Hand tighten the nut. Do not use a pipe wrench to tighten nut

INJECTOR FLOW RATE GRAPHS

VIOLET, ORDER NO. TBD
US Units

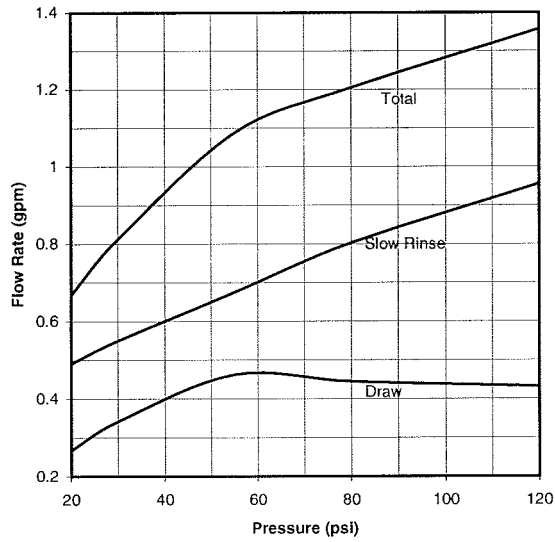

WHITE, ORDER NO. 101812
US Units

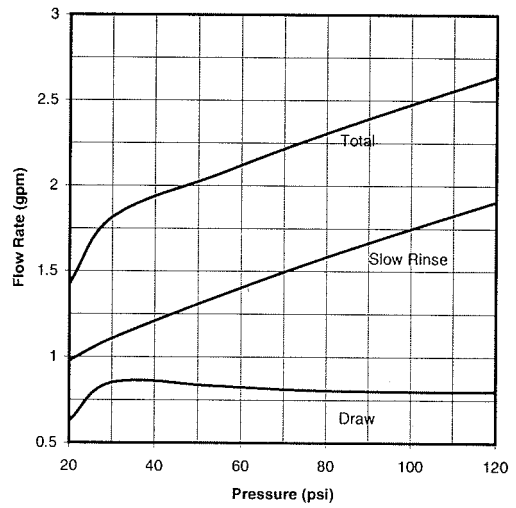

RED, ORDER NO. 101811
US Units

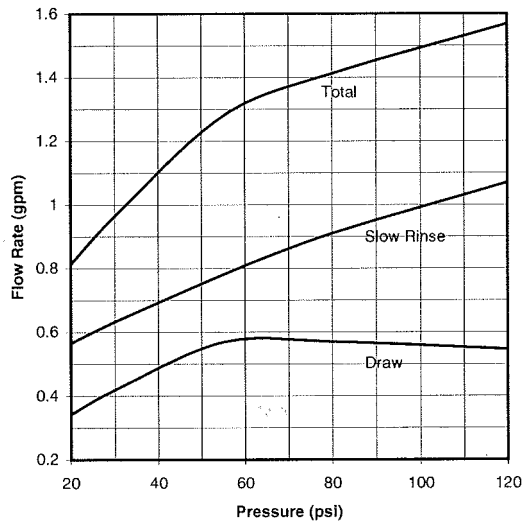

BLUE, ORDER NO. 101813
US Units

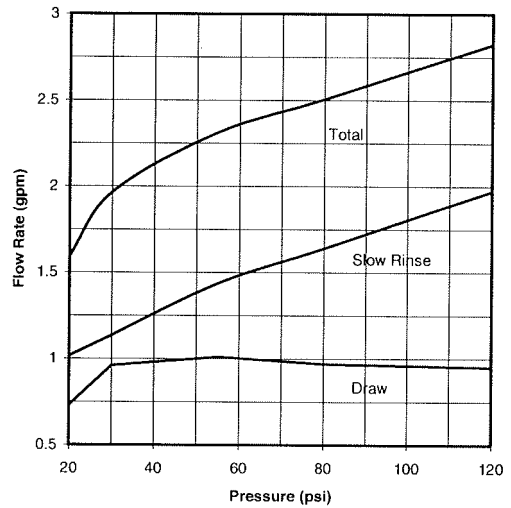

INJECTOR FLOW RATE GRAPHS

**YELLOW, ORDER NO. 101814
US Units**

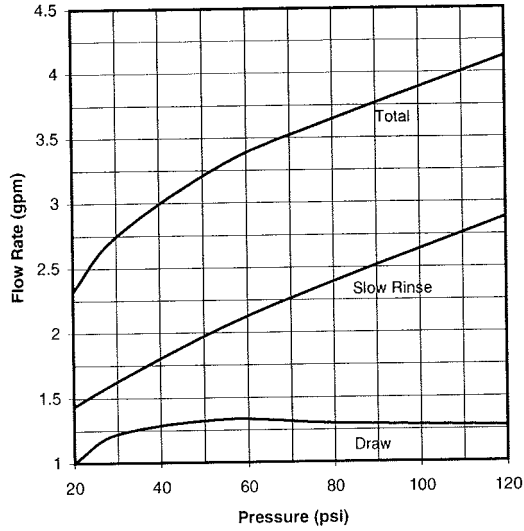

**ORANGE, ORDER NO. 101816
US Units**

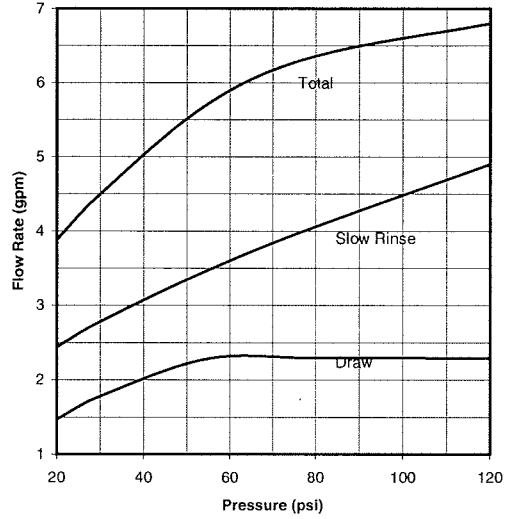

**GREEN, ORDER NO. 101815
US Units**

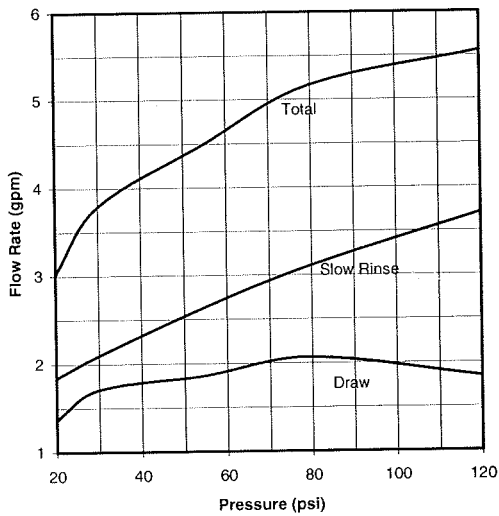

**GREY, ORDER NO. 109741
US Units**

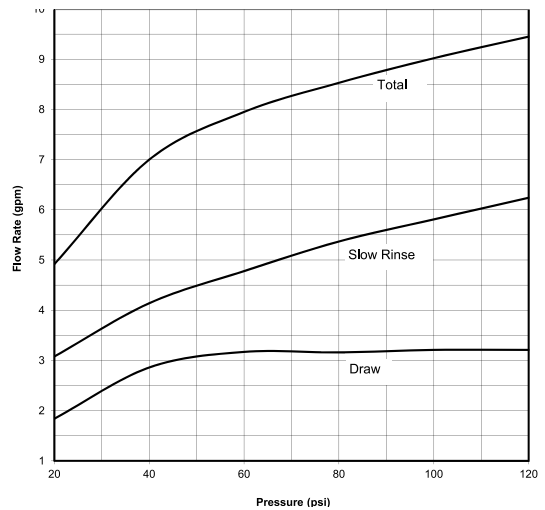

H151 HE SPECIFICATIONS

Model #	H151 HE-16	H151 HE-18	H151 HE-21	H151 HE-24	H151 HE-30
Regeneration Gallons on Factory Settings @ 35 psi	119	147	192	255	400
Capacity¹	Grains	Grains	Grains	Grains	Grains
High Efficiency Salting (5000gr/lb) ²	82,500	99,000	132,000	176,500	277,000
Low Salting (4800 grains/lb)	96,000	115,200	153,600	205,440	322,560
Service Flow Rates	GPM	GPM	GPM	GPM	GPM
Service Flow @ 15 psi	25	28	42	51	52
Peak Flow @ 25 psi	37	44	55	62	70
Resin Tank Size	16x65	18x65	21x62	24x72	30x72
Recommended Brine Tank	24x41	24x41	24x41	24x41	24x50
Brine Line Size	1/2"poly	1/2"poly	1/2"poly	1/2"poly	1/2"poly

Factory Settings in BOLD at 4800 grains/lb.

If Systemmate control used for demand recall, units are programmed as post fill and brine tank must be sized accordingly.

1. System conforms to ANSI/NSF 44 for performance claims as verified and substantiated by test data.
2. Maximum efficiency system can achieve, efficiency valid only at stated salt dose. The operational efficiency may be less than the tested efficiency due to individual application factors such as hardness, total dissolved solids, water usage and other contaminants in water that may reduce softener capacity.

Upflow high efficiency water softeners are intended for clean water such as municipal supplies or well water applications with proper pre-treatment. Operating parameters are for up to 0.5 ppm iron and 40 gpg hardness.

NOTES

COMMERCIAL WATER SOFTENER & FILTER LIMITED WARRANTY

INCLUDES – H125, H151, H200M, H200, H300, NF, TS, TN2 & TNT SYSTEMS

(Warranty Updated 10/14)

Hellenbrand, Inc., (“Hellenbrand”) warrants to the original purchaser that the system and the parts listed below will be free from defects in material and/or workmanship from the date of the original installation for the following time periods:

For a Period of FIVE YEARS: The filter control valve electrical parts including the motor and board, control valve body, and internal parts.

For a Period of FIVE YEARS: SystemMate Controller.

For a Period of TEN YEARS: Mineral tanks, 6” Diameter - 13” Diameter.

For a Period of FIVE YEARS: Mineral tanks, 14” Diameter - Up.

For a Period of FIVE YEARS: The salt storage/cabinet tank.

For a Period of ONE YEAR: The entire water conditioner system (“System”).

Any parts used for replacement are warranted for the remainder of the original warranty period for the applicable part.

THIS WARRANTY IS EFFECTIVE TO THE ORIGINAL PURCHASER ONLY, AND ONLY FOR AS LONG AS THE SYSTEM REMAINS AT THE ORIGINAL INSTALLATION SITE. COVERAGE TERMINATES IF YOU SELL OR OTHERWISE TRANSFER THE SYSTEM OR IF THE SYSTEM IS MOVED FROM THE ORIGINAL INSTALLATION SITE.

No sales representative, distributor, agent, dealer, reseller, authorized seller or any other person or entity is authorized to make any other warranty, or modify or expand the warranty provided herein on behalf of Hellenbrand. Upon expiration of the applicable warranty period, Hellenbrand shall have no further liability related to the System/parts to which the warranty period applies, except with respect to valid warranty claims asserted during the appropriate warranty period.

If the System or any part described above becomes defective within the specified warranty period, you should notify your local authorized seller of Hellenbrand products, and arrange a time during normal business hours for the inspection of the System at the original installation site. You may also contact Hellenbrand and we will provide you with the contact information for your local authorized seller of Hellenbrand products. Hellenbrand, at its option, will repair or replace the System or any part found defective within the terms of this warranty. You are responsible for freight from our factory and any service fees charged by the local authorized seller of Hellenbrand products for installation, repair, removal, replacement, service, etc., of any System or parts. This warranty does not include any labor charges. This paragraph sets forth the exclusive remedy for any valid warranty claims against Hellenbrand.

THIS WARRANTY DOES NOT COVER defects caused by sand, sediment or bacteria fouling, accident, fire, flood, Act of God, misuse, misapplication, neglect, alteration, installation or operation contrary to Hellenbrand’s printed instructions, or installation, repair or service by anyone other than Hellenbrand or an authorized seller of Hellenbrand products.

IN ADDITION, THIS WARRANTY DOES NOT COVER UNPROTECTED OUTDOOR INSTALLATIONS. This System, including all of the electrical components, must be protected against windblown dust, falling and windblown rain, freezing temperatures and the formation of ice, with an appropriate enclosure consisting of a floor, roof, walls, ventilation and heat.

As a manufacturer, we do not know the characteristics of your water supply or the purpose for which you are purchasing this system. You should be aware that the quality of water supplies may vary seasonally or over a period of time, and that your water usage rate may vary as well. Water characteristics may change considerably if this System is moved to a new location. For these reasons, Hellenbrand assumes no liability for the determination of the proper equipment necessary to meet your needs; and Hellenbrand does not authorize others to assume such obligations for Hellenbrand.

TO THE EXTENT PERMITTED BY APPLICABLE LAW, REMEDIES FOR DEFECTS OR FAILURES ARE LIMITED TO THE REMEDIES PROVIDED IN THIS WARRANTY. THERE ARE NO EXPRESS WARRANTIES OTHER THAN THOSE SET FORTH HEREIN. TO THE EXTENT PERMITTED BY APPLICABLE LAW, HELLENBRAND HEREBY DISCLAIMS ALL OTHER WARRANTIES, WHETHER STATUTORY, EXPRESS OR IMPLIED INCLUDING, WITHOUT LIMITATION, IMPLIED WARRANTIES OF MERCHANTABILITY, FITNESS FOR PARTICULAR PURPOSE, NON-INFRINGEMENT, OR ANY WARRANTIES ARISING FROM COURSE OF PERFORMANCE, COURSE OF DEALING, OR FROM USAGES OF TRADE.

UNDER NO CIRCUMSTANCES SHALL HELLENBRAND BE LIABLE TO THE ORIGINAL PURCHASER OR TO ANY OTHER PERSON FOR ANY INCIDENTAL, INDIRECT, SPECIAL OR CONSEQUENTIAL DAMAGES OR FOR ANY OTHER LOSS, DAMAGE, OR EXPENSE OF ANY KIND, INCLUDING LOSS OF PROFITS, WHETHER ARISING OUT OF BREACH OF WARRANTY, BREACH OF CONTRACT, IN TORT OR OTHERWISE, AND REGARDLESS OF WHETHER HELLENBRAND WAS AWARE OF THE POSSIBILITY OF SUCH LOSS. THESE LIMITATIONS WILL APPLY REGARDLESS OF ANY FAILURE OF ESSENTIAL PURPOSE OF ANY LIMITED REMEDY.

Some states do not allow limitations on how long an implied warranty lasts, so the above limitations may not apply to you. Similarly, some states do not allow the exclusion or limitation of incidental or consequential damages, so the above limitation or exclusion may not apply to you. This warranty gives you specific legal rights, and you may also have other rights which vary from state to state.