



CLICK ANYWHERE on THIS PAGE to RETURN TO HELLENBRAND WATER SOFTENERS at InspectApedia.com



H-125 SERIES™

WATER CONDITIONING SYSTEM 

System for Automatic Discharge Management - U.S. Patent No. 9,862,619
Method of Water Discharge Management - U.S. Patent No. 9,346,689 B2

Owner's Manual

p/n 109122 Rev. E
Updated 4/17/18
©2008-2018

Manufactured by:
HELLENBRAND, INC.
404 Moravian Valley Road • Waunakee, Wisconsin 53597
www.hellenbrand.com • info@hellenbrand.com

This owner's manual is designed to assist owners and installers with the operation, maintenance and installation of your new water softener. It is our sincere hope that this manual is clear, concise and helpful to both owner and installer. We have included detailed instructions on general operating conditions, pre-installation and installation instructions, start-up, and timer and meter programming. We have included a troubleshooting guide, service instructions and parts diagrams to assist you.

In the event that you need professional assistance for servicing your water softener, please contact the dealer who installed this system.

TABLE OF CONTENTS

Job Specification Sheet.....	3
Soft Water Basics	4
Operating Conditions.....	4
Pre-Installation Check List.....	5
Bypass Valve Operation	5
Water Softener Disinfection	5
Installation Instructions	6
Programming.....	7-16
-Set Time of Day	
-Softener Setup	
-Service Reminder	
-Diagnostics	
-Valve History	
-Cycle Sequence	
Water Softener Draining Procedure	17
Trouble Shooting	18-20
Conditioner and Brine Tank Assemblies	21
Parts Diagrams.....	22-26
Flow Diagrams.....	28-29
Programing Options.....	30
General Specification	30
Service Instructions	31-33
Pressure Drop Charts.....	34
Specifications	35
Warranty	36

Dealer Name _____ Phone _____

Address _____

JOB SPECIFICATION SHEET

MODEL NO. _____

*WATER TEST AT TIME OF INSTALLATION

_____ Hardness CaCo₃ (gpg) _____ Other _____
_____ Iron (ppm) _____ Other _____
_____ pH _____ Other _____

_____ **Reclamation mode enabled**
_____ **No Hard By-pass enabled**
_____ **Alternator system enabled**
_____ **Separate source enabled**

OPTIONAL RELAY SETTINGS

_____ Off

Relay 1 Trigger

_____ **On Time**
_____ Start Time, Minutes into Regeneration
_____ Run Time

_____ **On Gallons**
Pulse per _____ Gallons
_____ Time Relay Closed

_____ **On Regen Gallons**
(Relay activated on gallons through meter during regeneration and service flow)
Pulse per _____ Gallons
_____ Time Relay Closed

_____ **On Service Alarm**
_____ **On Lockout**

Relay 2 Trigger

_____ **On Time**
_____ Start Time, Minutes into Regeneration
_____ Run Time

_____ **On Gallons**
Pulse per _____ Gallons
_____ Time Relay Closed

_____ **On Regen Gallons**
(Relay activated on gallons through meter during regeneration and service flow)
Pulse per _____ Gallons
_____ Time Relay Closed

_____ **On Service Alarm**
_____ **On Lockout**
_____ **Error**

*SIZING INFORMATION

All Water is Softened Except:

_____ Rear Hose Bib _____ Front Hose Bib _____ Kitchen Cold _____ Toilets _____ All Cold
_____ Other _____

The average family uses 50 gallons per person daily for all water uses in the home, about 30 gallons per person daily if soft water is not supplied to the toilets, and about 20 gallons per person daily if only hot water is softened.

_____ Daily Water Usage (Gallons/Person)
x _____ Family Size (Number of people in family)
= _____ Total Gallons Per Day
x _____ Grains Per Gallon of Hardness
(Note: Add 3 grains per gallon of hardness for each ppm iron for total compensated hardness)
= _____ Total Grains Per Day

*INSTALLATION DATE _____

*SERIAL NUMBER _____

3 NOTES _____

SOFT WATER BASICS

Hardness

Hardness in water is the amount of calcium and magnesium present. A water softener removes the majority of calcium and magnesium to produce softened water.

Hardness is measured in units of grains per gallon. When your water is tested the hardness is calculated and expressed as grains per gallon (gpg). This calculation, as well as how much water is used in the building will help determine what type and size of water softener will most efficiently soften your water.

Your water softener contains an ion exchange media (sometimes called resin) which removes the hardness from water as it flows through the softener tank. Eventually so much hardness collects on the exchange media that the softener can no longer soften water. At this point it is considered "exhausted". Regeneration is now necessary.

Regeneration

When ion exchange resin is saturated with calcium and magnesium (hard water ions) it must be recharged. This is accomplished by rinsing the resin with a salt solution. The salt solution removes the hardness and replaces it with sodium. The exchange media is then ready to remove hardness from water. The hardness minerals and excess brine solution are rinsed down the drain.

During the regeneration cycle the softener is also backwashed. This reversing of the normal flow of water serves to remove sediment which may have accumulated during the softening process due to the filtering action of the exchange media. Backwashing also loosens and fluffs up the bed of exchange media to insure that during regeneration the brine solution will come into contact with all the ion exchange media.

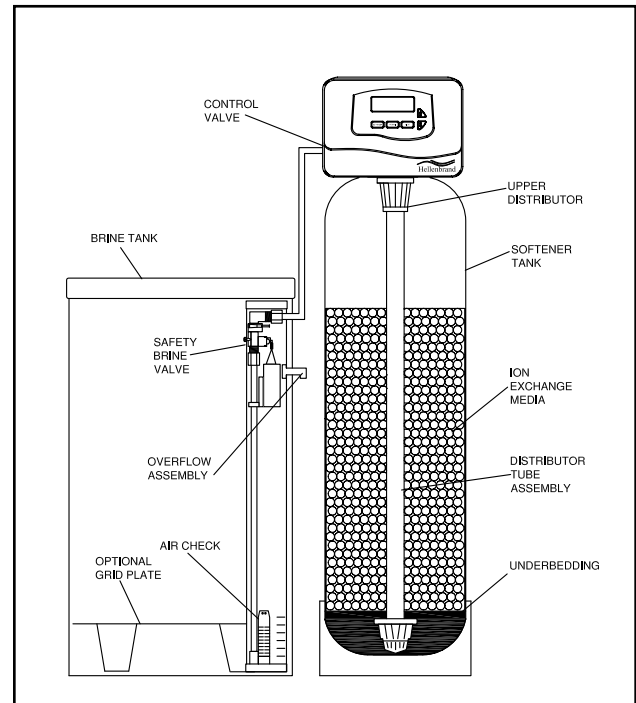

Figure 1

Maintenance of Your Softener

Salt: Salt to a softener is what gasoline is to a car. Not only must a softener have salt, but it should be the proper type to insure efficient recharging of the unit. Ask your dealer what type of salt may best suit your needs. Always have an adequate supply of salt on hand. Check the salt level of your brine tank every couple of weeks initially to determine how much salt you use - this will depend on how much water you use. As a rule of thumb, with 20 gpg hard water, about a 1/2 lb. of salt per person per day is used. In other words, a family of four uses 60 lbs. of salt a month. If your household does not use much water, do not fill your brine tank over 1/2 full, salt bridging may occur in the brine tank. This may result in hard water due to ineffective regeneration. Fill the tank approximately three-fourths full, with a minimum of 12" of salt. DO NOT USE block salt when the H-125 control is programmed with a brine tank refill. Block salt does not dissolve quick enough to provide a good regeneration.

Cleaning Brine Tank: Salt tank may require periodic cleaning. Inspect the brine tank at least once a year for buildup of insoluble materials. It is recommended to periodically clean the brine tank no matter what kind of salt you are using. See page 20, Miscellaneous #2 for details on cleaning.

REMEMBER: Salt is the fuel to run your water softener. Buy the **best clean salt available.**

OPERATING CONDITIONS

Your water conditioner has been designed to adequately handle up to 100 grains per gallon of hardness that might be encountered as well as up to 2 ppm of Ferrous Bicarbonate Iron. This is iron that is dissolved in an oxygen-free water supply. It is not visible to the eye in a freshly drawn sample because the water appears clear. But upon standing in contact with air, the ferrous iron will become oxidized to the ferric state and start to precipitate as a reddish brown flow. It can then be seen and if allowed to remain in the supply will cause discolored water. In order for your conditioner to remove the iron, air (oxygen) must

be kept from coming in contact with water until after it has been passed through the water conditioner. In some cases, additional equipment may be required to treat water supplies having special characteristics, such as: ferric hydroxide iron, iron bacteria, low pH, taste and odors, etc. If any question should exist, contact your dealer.

This water softener is not intended to be used for treating water that is microbiologically unsafe or of unknown quality without adequate disinfection before or after treatment.

PRE-INSTALLATION CHECK LIST

(All electrical & plumbing should be done in accordance to all local codes)

Water Pressure: A minimum of 25 pounds of water pressure (psi) is required for regeneration. Maximum 125 psi.

Water Quality: On rural water supplies there is often a problem with sand or sediment in the water. (This problem occasionally occurs in public water supplies also.) If the water is not filtered before being softened, the sand and sediment will plug up the water softener restricting the flow through the resin bed. This problem often requires rebedding of the mineral tank. **Note:** Well and/or pump problems affecting the operation of the softener are repairs that are not covered under warranty. To prevent these unnecessary, and expensive repairs not covered under warranty, we recommend the installation of an in-line filter system ahead of the softener.

Electrical: A continuous 110 volt, 60 cycle current supply is required. Make certain the current supply is uninterrupted and cannot be turned off with another switch. All electrical connections must be connected per local codes. **Surge protection is recommended with all electronic controls.**

Existing Plumbing: Condition of existing plumbing must be free from lime and iron build-up. Piping that is built-up heavily with lime and/or iron must be replaced. If piping is blocked with iron, additional equipment must be installed ahead of the water conditioner to correct the problem.

Drain Line: The conditioner should be located close to a drain. Avoid overhead drain lines if possible to prevent back pressure on the brine injector. Overhead drains are not to exceed 8 feet above the floor and no more than 20 feet in length. The pipe size for the drain line should be a minimum of 3/4". Backwash flow rates in excess of 7 gpm or length in excess of 20' require 1" drain line.

Bypass Valves: Always provide for the installation of a bypass valve.

Softening: It is recommended that the conditioner be installed to soften both the hot and cold water supply. A separate hard water faucet may be plumbed for drinking purposes if you desire. Outside faucets should be left on hard water.

Caution: Water temperature is not to exceed 110°F; the conditioner cannot be subject to freezing conditions, or to a vacuum due to loss of pressure (such as a water main break).

BYPASS VALVE OPERATION

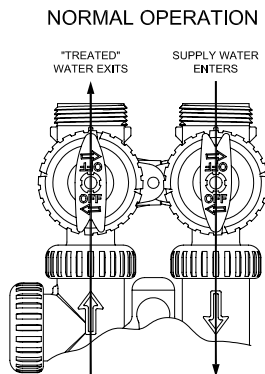

Figure 3

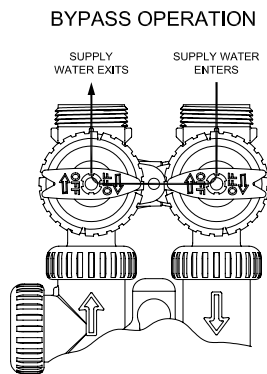

Figure 4

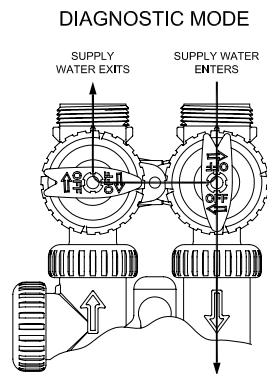

Figure 5

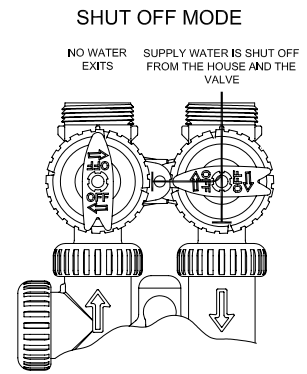

Figure 6

WATER SOFTENER DISINFECTION

The construction materials of your water softener will not support bacterial growth nor will these materials contaminate a water supply. However, the normal conditions existing during shipping, storage, and installation indicate the advisability of disinfecting a softener after installation, before the softener is used to treat potable water. In addition, during normal use a softener may become fouled with organic matter or in some cases, with bacteria from the water supply.

Therefore, every water softener should be disinfected after installation, some will require periodic disinfection during their normal life. You have two choices for disinfection as follows:

- A. **SODIUM HYPOCHLORITE** (household bleach)
5.25% SODIUM HYPOCHLORITE solutions are available under such trade names such as Clorox, Lincor, Bo Peep,

White Sail and Eagle Brand Bleach. If stronger solutions are used, such as those sold for commercial laundries, adjust the dosage accordingly.

1. Dosage:
 - a. Softening resin; 1.2 fluid ounce per cubic foot of resin.
2. Add the required amount of hypochlorite solution to the brine well of the brine tank.
 - a. Proceed with the normal regeneration. Press **REGEN** and allow the water softener to go through a normal regeneration.

- B. EPA and NSF approved Sani-System by Pro Products. This can be purchased from your water treatment provider or at: <http://proproducts.com/products/sani-system>.

INSTALLATION INSTRUCTIONS

(All electrical & plumbing should be done in accordance to all local codes)

- Do not use vaseline, oils, other hydrocarbon lubricants or spray silicone anywhere. A silicon lubricant may be used on black o-rings but is not necessary. **Avoid any type of lubricants, including silicone, on red or clear lip seals.**
 - Do not use vaseline, oils, other hydrocarbon lubricants, or spray silicone anywhere. Teflon tape is not necessary on the nut connection or caps because of o-ring seals.
 - The pipe size for the drain line should be a minimum of 3/4". Backwash flow rates in excess of 7 gpm or length in excess of 20' require 1" drain line.
- Place the conditioner where you want to install it, making sure it is on a clean, level and firm base.
 - Do all necessary plumbing (inlet to inlet, outlet to outlet and drain line to drain). The control valve, fittings and/or bypass are designed to accommodate minor plumbing misalignments but are not designed to support the weight of a system or the plumbing.
 - When assembling the installation fitting package (inlet and outlet), connect the fitting to the plumbing system first and then attach the nut, split ring and o-ring. Heat from soldering or solvent cements may damage the nut, split ring or o-ring. Solder joints should be cool and solvent cements should be set before installing the nut, split ring and o-ring. Avoid getting primer and solvent cement on any part of the o-rings, split rings, bypass valve or control valve.
 - A jumper ground wire should be installed between the inlet and outlet pipe whenever the metallic continuity of a water distribution piping system is interrupted. Install jumper ground wire on metal pipes.**
 - The drain connection may be made using a 3/4" or a 1" female adapter (see figure 6a). If soldering, joints near the drain must be done prior to connecting the drain line flow control

fitting. Leave at least 6" between the drain line control fitting and solder joints when soldering pipes that are connected on the drain line control fitting. Failure to do this could cause interior damage to the drain line flow control fitting.

- The brine refill flow control assembly is installed in an easy to access refill elbow located on top of the control valve. The refill flow control assembly is attached to the control valve with a locking clip. The locking clip allows the elbow to rotate 270 degrees so the outlet can be orientated towards the brine tank.
- Connect the brine line found in the brine tank to the brine connection on the control valve. The control valve has a standard refill elbow which a 3/8" flexible tube can be connected, see figure 6a, page 6. (An optional elbow can be ordered which accommodates a 1/2" flexible tube for a high regenerant draw rate situation). Both elbows use the same refill flow control and retainer. Do not connect the other end of the brine line to the safety brine valve in the brine tank at this time. Make sure the floor is clean beneath the salt tank and that it is level and smooth.
- A 1/2" (inside diameter) gravity drain line should be connected to the overflow elbow on the side of the brine tank and run to a drain below the level of the elbow. This overflow drainage system provides protection from water damage in the event of a brine shut-off malfunction. Tubing is not provided to do this.

In all cases where an overflow could result in water damage for various reasons, this overflow protection must be used. Do not connect the tubing to the drain line on the control valve discharge line and do not run this line above the overflow elbow height at any point. Provide air gap.

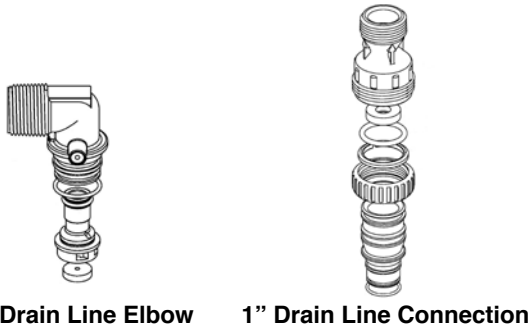

3/4" Drain Line Elbow 1" Drain Line Connection

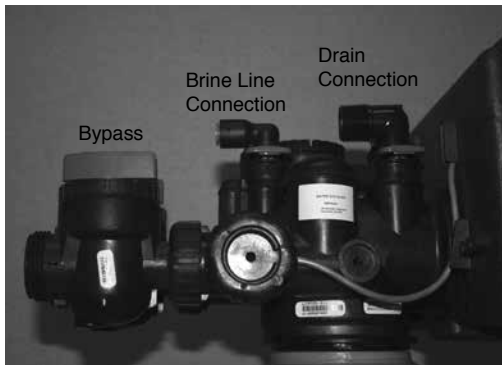

Figure 6a

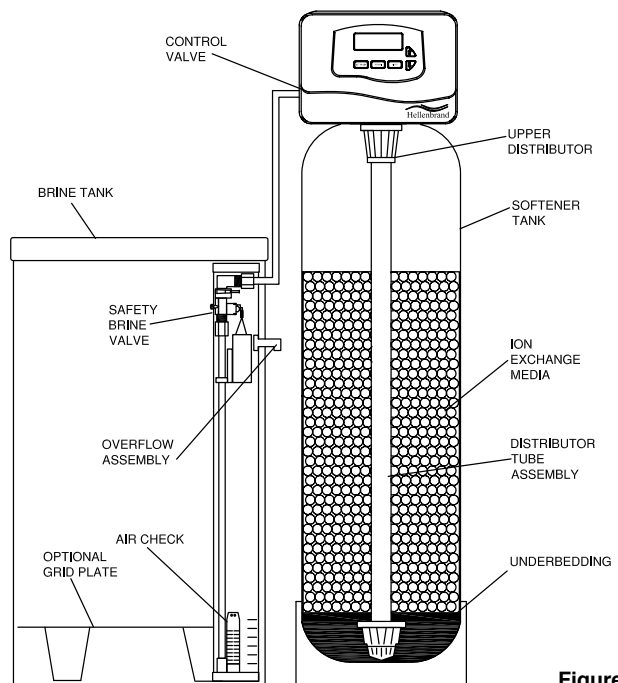

Figure 6b

PROGRAMMING

General Information

The H125 control valve is the “brain” of your water softener. It consists of the valve body and powerhead with solid state microprocessor.

The display panel (see Figure 7) consists of the LCD display and five push buttons which are used in displaying and programming the water softener settings.

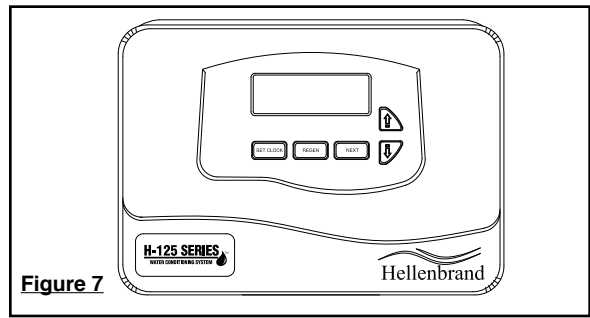

Figure 7

Initial Start Up

The initial start up will probably be done by the technician installing the softener system. If not, the following instructions will step through the process.

1. Complete all plumbing connections: inlet, outlet, drain line and brine line. Do not add salt at this time.
2. Place the bypass valve in the bypass position. (See figure 3 page 5) Turn on the main water supply. Open a cold soft water faucet to flush the piping of any air and/or foreign material. Run until the water is clear.
3. Manually add 6 inches of water to the brine tank.
4. Now plug the transformer into a 110-volt receptacle. (Be certain the outlet is uninterrupted.) Within 5 seconds the control will automatically align itself into the softening mode and display will automatically alternate between time of day, gal/min and gallons remaining. (Figure 8).
5. Set the time of day by pushing clock button (figure 9, page 8) and using ▲ and ▼ buttons.
6. Push REGEN button and hold it down for 3 seconds. The system will advance to the “First” position. (Note: Depending on how the system is programmed it could read backwash, rinse, brine or fill). Keep pushing REGEN button until “Rinse” shows in the lower right hand corner of display. Slowly place the by-pass into the “diagnostic mode” (see fig 4, page 5). Run water to the drain until it runs clear. Return the by-pass valve to the by-pass position (fig 3, page 5). Push REGEN button until “unit is back to softening mode.”
7. Once again, push REGEN button and hold down for 3 seconds. Keep pushing REGEN button until “Backwash” appears. Slowly place the by-pass valve into the

“Diagnostic Mode” 1/2 way. Allow water to slowly fill the mineral tank. When a solid stream of water starts coming out of the drain line, open the by-pass inlet valve all the way and allow to run out the drain until water clears. Then slowly place the by-pass into the “normal operation” mode by opening the outlet side of by-pass valve, figure 2, page 5.

8. Press the REGEN button until LED display says “REGENERANT DRAW-DN”. Loosen the brine line from the control valve. Place finger over the end of brine connection on valve to check for suction. If no suction, see trouble-shooting guide. (See #10, Page 22) If proper suction, attach brine tube to control valve, and allow it to draw water down to the bottom of the air check, (figure 6b, page 6).
9. Press REGEN button again until LED once again displays “BACKWASH”. Keep in backwash until water once again runs clear at the drain.
10. Press REGEN button again until “RINSE” is displayed. Allow rinse cycle to run its full course. While the rinse cycle is finishing, this would be a good time to load your brine tank with salt. **If utilizing brine recovery, add full volume of water to brine tank for the 1st REGENERATION.**
11. Once the rinse cycle has finished, the softener control will return to the softening cycle. The LED screen will scroll between “TIME/GPM/GALLONS REMAINING”.
12. Next set your softeners water hardness, days override and regeneration time settings (see figure 10a, page 8).

Your programming is now complete.

General Operation

When the system is operating, one of several displays may be shown. Pressing NEXT will alternate between the displays. One of the displays is the current time of day. The second display is days to a regen/gallons remaining. Days To A Regen is the number of days left before the system goes through a regeneration cycle. Capacity remaining is the number of gallons that will be treated before the system goes through a regeneration cycle. The third display is current flow in gal/min. The user can scroll between the displays as desired by pushing NEXT or display will scroll automatically.

When water is being treated (i.e. water is flowing through the system) the word "GPM" flashes on left side of display when other than flow rate is displayed.

USER DISPLAYS/SETTINGS

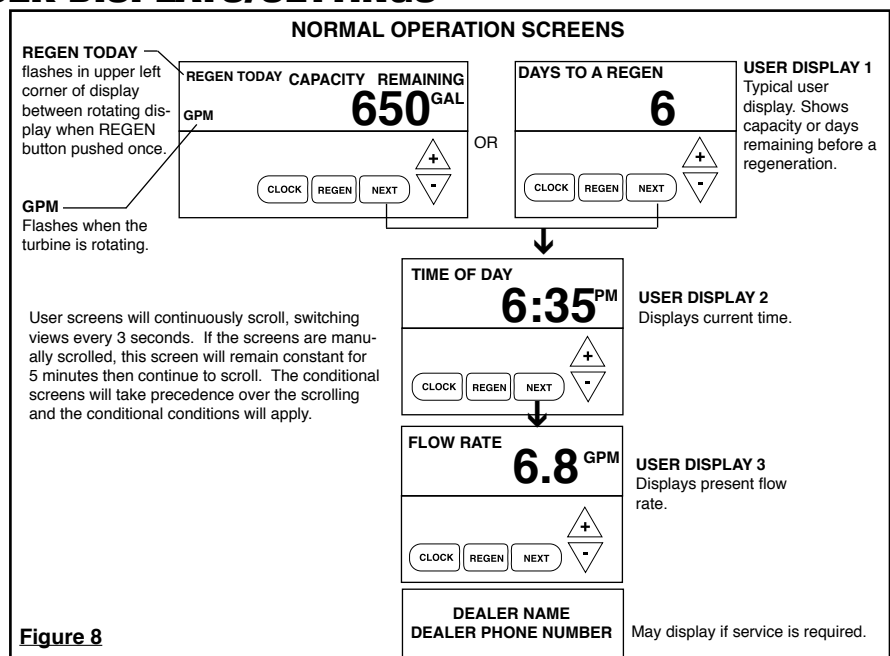
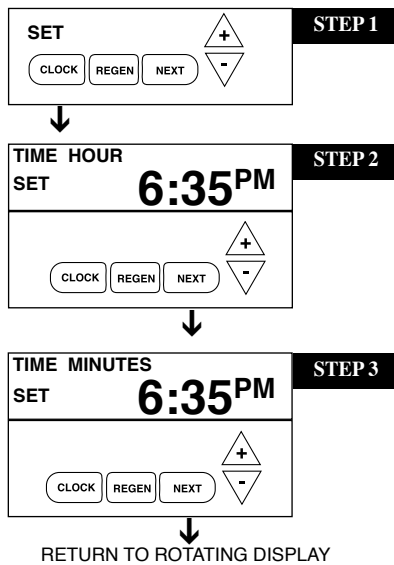

Figure 8

SET TIME OF DAY



▲ = ▲ Up Arrow ▼ = ▼ Down Arrow

Step 1 - Press SET CLOCK.

Step 2 - Current Time (**hour**): Set the hour of the day using ▲ or ▼ buttons. AM/PM toggles after 12. Press NEXT to go to step 3.

Step 3 - Current Time (**minutes**): Set the minutes of day using ▲ or ▼ buttons. Press NEXT to exit Set Clock. Press REGEN to return to previous step.

Power Loss - Lithium battery on circuit board provides up to 2 years of time clock backup during power outages. If the power is out when battery is depleted, only time of day needs to be reset, all other values are stored in non-volatile memory. When time of day is flashing, replace lithium coin type 2032 battery.

Battery back-up feature will be activated after 24 hours of power.

Do not forget to reset for daylight savings time.

Figure 9

INSTALLER DISPLAYS/SETTINGS

▲ = ▲ Up Arrow ▼ = ▼ Down Arrow

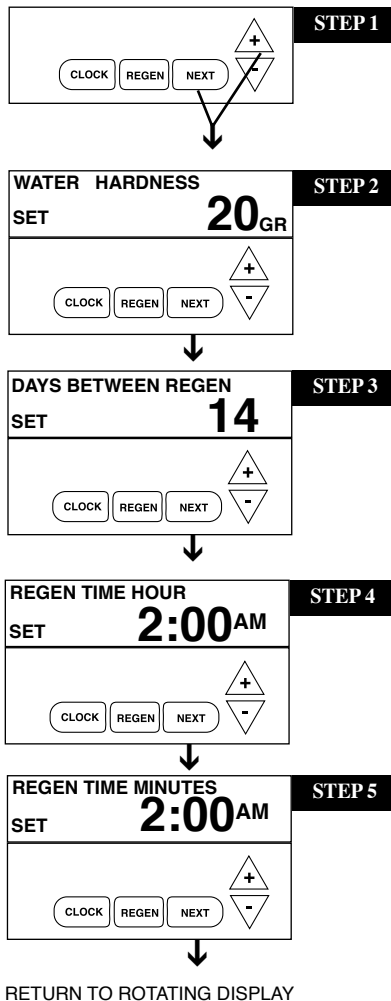

Step 1 - Press NEXT and ▲ simultaneously for 3 seconds.

Step 2 - Hardness: Set the amount of total compensated hardness in grains (hardness as calcium carbonate) per gallon using ▲ or ▼ buttons. **The factory setting is 20** with value ranges from 1 to 150 in 1 grain increments. Note: The grains per gallon should be increased if soluble iron needs to be reduced. Add 3 grains of hardness for each ppm of iron present. If this display shows nA -, then system is set-up in "filter" mode or "AUTO" is not selected in softener system setup. (See page 33). Press NEXT to go to Step 3. Press REGEN to exit Installer Displays/Settings.

Step 3 - Day Override: This sets the number of days between regenerations. If value set to "oFF" regeneration initiation is based solely on gallons used. If value is set as a number (allowable range from 1 to 28) a regeneration initiation will be called for on that day even if sufficient number of gallons were not used to call for a regeneration. Set Day Override using ▲ or ▼ buttons: **Factory setting is 14 days.**

- number of days between regeneration (1 to 28); or
- "oFF"

See pages 9-13, for more detail on softener setup. Press NEXT to go to step 4. Press REGEN to return to previous step.

Step 4 - Regeneration Time (hour): Set the hour of day for regeneration using ▲ or ▼ buttons. AM/PM toggles after 12. The factory setting time is 2:00 a.m. This display will show "REGEN" "IMMEDIATE ON ZERO GAL" if "Immediate" is selected on Step 12 of softener set-up. See page 33. Press NEXT to go to step 5. Press REGEN to return to previous step.

Note: When installing this unit as part of a multi unit parallel system the regen time of day must be adjusted to prevent multiple units from regenerating at the same time.

Step 5 - Regeneration Time (minutes): Set the minutes of day for regeneration using ▲ or ▼ buttons. This display will not be shown if system is set for immediate regeneration. Press NEXT to exit Installer Displays/Settings. Press REGEN to return to previous step.

Figure 10a

Manual Regeneration

Sometimes there is a need to regenerate the system, sooner than when the system calls for it, usually referred to as manual regeneration. There may be a period of heavy water usage because of guests or a heavy laundry day.

To initiate a manual regeneration at the preset delayed regeneration time, press and release "REGEN". The words "REGEN TODAY" will flash in left corner of display as it scrolls through displays to indicate that the system will regenerate at the preset delayed regeneration time. If you pressed the "REGEN" button in error, pressing the button again will cancel the request.

To initiate a manual regeneration immediately, press and hold the "REGEN" button for five seconds. The system will begin to regenerate immediately. The request cannot be cancelled. You must cycle all the way through the cycles to make it stop. PLEASE NOTE: This will reset the meter.

Note: If the salt tank does not contain salt, fill with salt and wait at least two hours before regenerating. If two regenerations are desired within 24 hour period, press /release REGEN button. REGEN TODAY will flash on screen. Press and hold REGEN button until valve initiates regeneration.

Regeneration Mode

Typically a system is set to regenerate at a time of low water usage. An example of a time with low water usage is when the household is asleep. If there is a demand for water when the system is regenerating, untreated water will be supplied.

When the system begins to regenerate, the display will change to include information about the step of the regeneration process and the time remaining for that step to be completed (see figure 11). The system runs through the steps automatically and will reset itself to provide treated water when the regeneration has been completed.

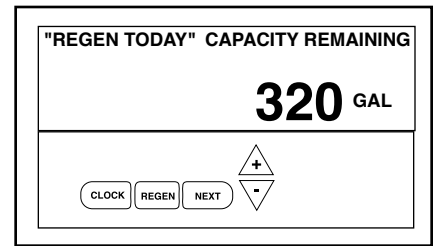

Regeneration Step
(shows time remaining in regen step is 8 minutes, 22 seconds)

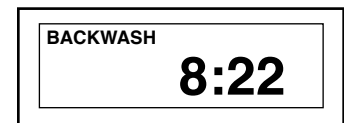

Figure 11

CYCLE TIME ADJUSTMENTS

Normally it is not recommended to adjust the lengths of the cycle times. However, certain water conditions may dictate adjustments. This should only be done from the recommendation of a water conditioning professional. The following chart shows the upper and lower limits of each cycle.

Cycle Options	Units	Lower/Upper Limit	Factory Setting
Service	NA	NA	See Page 43
Backwash	Minutes	1 to 120	10
Regenerant Draw DN	Minutes	1 to 120	60
Fast Rinse	Minutes	1 to 120	6
Refill Brine Tank	Minutes	1 to 120	See Page 43

SOFTENER SETUP

▲ = ▲ Up Arrow ▼ = ▼ Down Arrow

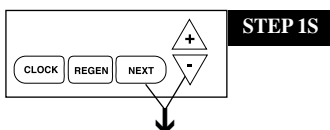

STEP 1S

STEP 1S – Press NEXT and ▼ simultaneously for 3 seconds. If screen in Step 2S does not appear in 5 seconds the lock on the valve is activated.

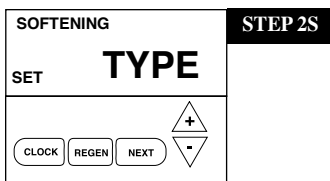

STEP 2S

STEP 2S – Select between softening or filtering. A flashing "SOFTENING" or "FILTERING" will appear. Choose SOFTENING using ▼ or ▲ button. **Factory setting is Softening.** Press NEXT to go to Step 3S. Press REGEN to exit Softener System Setup.

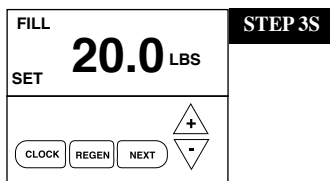

STEP 3S

STEP 3S – Select the time for the first cycle (which in this example is FILL, setting is changed by lbs. of salt entered) using the ▼ or ▲ button. **Factory setting is Medium Salting,** See page 39. Press NEXT to go to Step 4S. Press REGEN to return to previous step.

STEP 4S

SOFTENING TIME

SET **120:00** MIN

CLOCK REGEN NEXT

▲
▼

STEP 4 S – Select the time for the second cycle (which in this example is SOFTENING) using ▼ or ▲ button. Press NEXT to go to Step 5S. Press REGEN to return to the previous step.

STEP 5S

BACKWASH TIME

SET **8:00** MIN

CLOCK REGEN NEXT

▲
▼

STEP 5 S – Select the time for the third cycle (which in this example is BACKWASH) using the ▼ or ▲ button. Press NEXT to go to Step 6S. Press REGEN to return to the previous step.

STEP 6S

DRAW TIME

SET **60:00** MIN

CLOCK REGEN NEXT

▲
▼

STEP 6 S – Select the time for the fourth cycle (which in this example is BRINE DRAW) using the ▼ or ▲ button. Press NEXT to go to Step 7S. Press REGEN to return to the previous step.

STEP 7S

BACKWASH TIME

SET **8:00** MIN

CLOCK REGEN NEXT

▲
▼

STEP 7 S – Select the time for the fifth cycle (which in this example is Second BACKWASH) using the ▼ or ▲ button. Press NEXT to go to Step 8S. Press REGEN to return to the previous step.

STEP 8S

RINSE TIME

SET **4:00** MIN

CLOCK REGEN NEXT

▲
▼

STEP 8 S – Select the time for the sixth cycle (which in this example is RINSE) using the ▼ or ▲ button. Press NEXT to go to Step 9S. Press REGEN to return to the previous step.

STEP 9S

GRAIN OF CAPACITY

SET **64.0** x1K

CLOCK REGEN NEXT

▲
▼

STEP 9 S - Set Grain Capacity using the ▼ or ▲ button. The ion exchange capacity is in grains of hardness as calcium carbonate for the system based on the pounds of salt that will be used. The allowable grains capacity range varies from 5,000 to 3,000,000 grains. The increment increase is 500 for the range from 5000 to 30,000; 1000 for the range of 30,000 to 100,000; and 2000 for the range of 100,000 to 3,000,000. Grains capacity is affected by the fill time. The grains capacity for the selected lbs. salting should be confirmed by testing. The capacity and hardness levels entered are used to automatically calculate reserve capacity when gallon capacity is set to AUTO. **Factory setting is the capacity of the softener at medium salting.** See Page 43. Press NEXT to go to Step 10S. Press REGEN to return to previous step.

STEP 10S

RESERVE CALCULATOR

SET **AUTO**

CLOCK REGEN NEXT

▲
▼

STEP 10 S – Set Gallons Capacity using ▼ or ▲ button. If value is set to:

- “AUTO” gallon capacity will be automatically calculated and reserve capacity will be automatically estimated;
- “oFF” regeneration will be based solely on the day override set (see Installer Display/Settings Step 3, page 8 / proportional brining will not function if OFF selected); or
- as a number of gallons (allowable range 20 to 1,500,000) regeneration will be based on the value specified.

Increment increase is 20 for the range 20 to 2000, 100 for the range of 2000 to 10,000 and 500 for the range of 10,000 to 50,000 and 2000 for range of 50,000 to 1,500,000. If “oFF” or a number is used, hardness cannot be set in Installer Displays/Settings Step 2, page 8. See page 35 for more detail. **Factory Setting is AUTO.** Press NEXT to go to Step 11 S. Press REGEN to return to previous step.

DELAY + IMMEDIATE
SET **REGEN**

CLOCK REGEN NEXT

+
-

STEP 11S

STEP 11 S – Set Regeneration Time Options using the ▼ or ▲ button. If value is set to:

- “DELAY” means regeneration will occur at the preset time; (page 8, step 4)
 - “IMMEDIATE” means regeneration will occur immediately when the gallons capacity reaches 0 (zero); or
 - “DELAY + IMMEDIATE” means regeneration will occur at one of the following:
 - the preset time when the gallons capacity falls below the reserve or the specified number of days between regenerations is reached, whichever comes first; or
 - immediately after 10 minutes of no water usage when the gallon capacity reaches 0 (zero).
- Delay + Immediate is NOT available if control is programmed as a twin alternating configuration. Selecting "DELAY" will result in an immediate alternation upon capacity depletion but regeneration is delayed to preset time.

See page 33 for more options. **Factory Setting is DELAY + IMMEDIATE.** Press NEXT to go to Step 12S. Press REGEN to return to previous step.

RELAY 1 "TIME"
SET **TRIGGER**

CLOCK REGEN NEXT

+
-

STEP 12S

STEP 12 S – Set Relay to activate by Time, Gallons, Regen Gallons, Lockout, Off or

Service Alarm by using ▼ or ▲ buttons. A relay can be used to operate a chemical feed pump or solenoid, etc. The choices are:

- Relay Triggered on Time - Relay activates after set number of minutes after start of regeneration. Start of regeneration is defined by first backwash cycle, dn brine or up brine, whichever is first. Relay deactivates after set time. Press NEXT for programming.
- Relay Triggered on Gallons - Relay activates every set number of gallons while in service and deactivates after set time. Press NEXT to go to 16S for programming.
- Relay Triggered on Regen Gallons - Relay activates after set number of gallons in service or gallons used during regeneration and de-activates after set time or when meter stops registering flow, whichever comes first. Press NEXT to go to 19S for programming.
- Service Alarm - Relay activates on service alarm setting: gallons, time or both, see step 21S.
- Relay Triggered for Lockout - Relay is activated at set number of minutes into regeneration including negative numbers to energize relay prior to regeneration starting. Selection of energizing relay for complete regeneration cycle is available by selecting REGEN for time setting, see step 22S.
- **Off** - If off is selected, Steps 13S – 24S will not be shown. **Factory setting = OFF.** Press NEXT to go to step 13S or other selection for relay settings, or 25S if OFF selected.

RELAY 1 SET POINT
SET **10** MIN

CLOCK REGEN NEXT

+
-

STEP 13S

STEP 13 S – If off was selected in previous step, this screen does not appear.

Time chosen to Activate Relay, use up and down arrows to set # of minutes AFTER START OF REGEN to activate relay. Start of regeneration is defined as first Backwash or Regenerant Draw mode. Time Range = 1 – 500 minutes. Press NEXT to go to Step 14S.

RELAY 1 DURATION
SET **3:00** MIN

CLOCK REGEN NEXT

+
-

STEP 14S

STEP 14 S – Use Up and Down arrows to set duration of relay activation in minutes. Range is 0:01 (1 second) to 500:00 (500 minutes). Press NEXT to go to Step 25S. Press REGEN to return to previous step.

RELAY 1 "GALLONS"
SET **TRIGGER**

CLOCK REGEN NEXT

+
-

STEP 15S

STEP 15 S – Gallons chosen to activate relay. If Off or Time was selected in previous steps, this screen does not appear. Press NEXT for trigger programming.

RELAY 1 SETPOINT
SET **1** GAL

CLOCK REGEN NEXT

+
-

STEP 16S

STEP 16 S – Use up and down arrows to set # of gallons per relay activation.

Range = 0.1 – 20,000 gallons. Press NEXT for Relay Duration. Press REGEN to return to previous step.

RELAY 1 DURATION
SET **0:01** MIN

CLOCK REGEN NEXT

+
-

STEP 17S

STEP 17 S – Use up and down arrows to set duration of relay activation in minutes.

Range = 0:01 (1 second) - 500:00 (500 minutes). Press NEXT to go to Step 25S. Press REGEN to return to previous step.

RELAY 1 "REGEN GALLONS" STEP 18S

SET **TRIGGER** GAL

CLOCK REGEN NEXT

▲
▼

STEP 18 S – REGEN gallons chosen to activate relay. Relay activates after set number of gallons have gone through meter in service **or** during regeneration and then deactivates after set period of time or after flow stops, whichever comes first. Press NEXT to go to Step 19S.

RELAY 1 SET POINT STEP 19S

SET **1** GAL

CLOCK REGEN NEXT

▲
▼

STEP 19S – Use up and down arrows to select number of gallons per relay activation of regen gallon setting. Range: 0.1 -20,000 gallons. Press NEXT to go to Step 20S.

RELAY 1 DURATION STEP 20S

SET **0:01** MIN

CLOCK REGEN NEXT

▲
▼

STEP 20S – If Off or Time was selected in previous steps, this screen does not appear. Use up and down arrows to set duration of relay activation in minutes. Range = 0:01 (1 second) - 500:00 (500 minutes). Press NEXT to go to Step 25S. Press REGEN to return to previous step. Meter does not read during regeneration.

RELAY 1 SERV ALARM STEP 21S

SET **TRIGGER**

CLOCK REGEN NEXT

▲
▼

STEP 21S – Service Alarm chosen to activate relay, relay closes whenever Service Alarm has triggered. Programming for relay closure on service reminder is done on Step 26S. Relay opens when service alarm reset. Press NEXT to go to Step 25S to set Relay 2 Settings. If off selected for Relay 2, service reminder programming on Step 26S.

- Relay closes on Gallons
- Relay closes on Time
- Relay closes on Both
- Off, **Factory setting is off**

RELAY 1 LOCKOUT STEP 22S

SET **TRIGGER**

CLOCK REGEN NEXT

▲
▼

STEP 22S – Relay Triggered for Lockout, relay closes at set time before or after start of regeneration. Start of regeneration is first backwash or brine draw cycle whichever comes first. A negative start time delays regeneration by that amount. Unlike "Time" mode, relay remains active during error, power failure and after manual advance. If manually advancing through regeneration, reset by holding NEXT/REGEN buttons after regeneration is complete. "REGEN" setting activates relay 2 minutes before and 2 minutes after regeneration. Access REGEN setting by holding DOWN button through all negative numbers.

RELAY 1 SETPOINT STEP 23S

SET **-20** MIN

CLOCK REGEN NEXT

▲
▼

STEP 23S – Use up or down arrows to select start time into regeneration to energize relay (regeneration is defined by start of backwash or draw; whatever comes first). Range = -20 – 500 minutes or select REGEN. Select REGEN if relay activation is desired for complete regeneration. When REGEN selected for lock-out, 2 min delay is built in prior to MAV movement. Press NEXT to select duration of relay activation.

RELAY 1 DURATION STEP 24S

SET **70:00** MIN

CLOCK REGEN NEXT

▲
▼

STEP 24S – Use up or down arrows to select duration of relay activation. Range = 0:01 (1 second) - 500:00 (500 minutes). Press NEXT to go to Relay 2 programming.

RELAY 2 TRIGGER STEP 25S

SET **REGEN** GAL

CLOCK REGEN NEXT

▲
▼

STEP 25S – Relay 2 programming includes identical options as Relay 1 with the addition of the ability to trigger Relay 2 in Error Mode. Relay closes whenever control enters Error Mode and immediately deactivates when Error resolved and control reset. Press NEXT to go to Step 26S.

SERVICE REMINDER

SERVICE ALARM	
SET	BOTH
CLOCK	REGEN NEXT

STEP 26S

STEP 26S – Set scheduled service display using ▲ or ▼ buttons. Available options are OFF, TIME, ON GAL or BOTH. Selecting OFF disables this feature. If OFF is selected, press NEXT to exit System Setup. If TIME, ON GAL or BOTH is selected press NEXT to select the TIME and/or ON GAL values. See Steps 27S and/or 28S. This can also activate relay if Service Alarm is selected on Step 21S. Press REGEN to return to the previous step.

SCHEDULED SERVICE	
SET	0.25 YR
CLOCK	REGEN NEXT

STEP 27S

STEP 27S – Service alarm for TIME ranges from 0.25 to 9.75 years. Press ▲ and ▼ buttons together until "SET" appears, use arrows to set. Press NEXT to either exit System Setup or if BOTH was selected go to Step 28S. When time selected and days remaining falls below 1 year, display following will show "scheduled service in xxx days" so technician can reset to pre-programmed time if desired. Press REGEN to return to the previous step.

SCHEDULED SERVICE	
SET	80000 GAL
CLOCK	REGEN NEXT

STEP 28S

STEP 28S – Service alarm for ON GAL ranges from 100 to 9,999,900 gallons. Press ▲ and ▼ buttons together until "SET" appears, use arrows to set. Press NEXT to exit System Setup. Press REGEN to return to the previous step.

Reset service reminder by holding down up and down arrows together when reminder is displayed.

RETURN TO NORMAL MODE

DIAGNOSTICS

To reset diagnostic data push "Next" & ▼ button until TYPE appears in window, then press "▲ & ▼" button simultaneously for 3 seconds or until screen changes.

CLOCK	REGEN NEXT
-------	------------

STEP 1D

STEP 1D – Press ▼ or ▲ simultaneously for three seconds. If screen in step 2D does not appear in 5 seconds the lock on the valve is activated.

DAYS SINCE REGEN	
	2 DAY
CLOCK	REGEN NEXT

STEP 2D

STEP 2D – Days, since last regeneration: This display shows the days since the last regeneration occurred. Press the NEXT button to go to Step 3D. Press REGEN to exit Diagnostics.

SINCE LAST REGEN	
	342 GAL
CLOCK	REGEN NEXT

STEP 3D

STEP 3D – Volume, since last regeneration: This display shows gallons of water that has been treated since the last regeneration. This display will equal zero if a water meter is not installed. Press the NEXT button to go to Step 4D. Press REGEN to return to previous step.

RESERVE HISTORY	
DAY	0 160 GAL
CLOCK	REGEN NEXT

STEP 4D

STEP 4D – Volume of reserve capacity used for last 7 days: If the unit is set up as a softener, a meter is installed and Set Volume Capacity is set to "Auto", this display shows 0 day (for today) and the reserve capacity. Pressing the ▲ button will show day 1 (which would be yesterday) and displays the reserve capacity. Pressing the ▲ button again will show day 2 (the day before yesterday) and the reserve capacity. Keep pressing the ▲ button to show the capacity for days 3, 4, 5 and 6. The ▼ button can be pressed to move backwards in the day series. Press NEXT button at any time to go to Step 5D. Press REGEN to return to previous step.

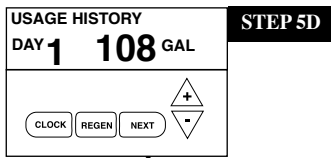

STEP 5D

STEP 5D – Volume of water used, 63-day usage history: This display shows day 0 (for today) and 1 (for yesterday) will show day 2 (which would be the day before yesterday) and flashes the volume of water treated on that day. Continue to press the ▲ button to show the volume of water treated for the last 63 days. If a regeneration occurred on the day the "letter R" will also be displayed. This display will show dashes if a water meter is not installed. Press the NEXT button at any time to go to Step 6 D. Press REGEN to return to the previous step.

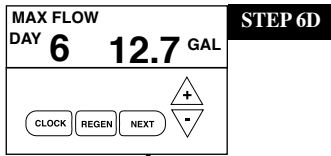

STEP 6D

STEP 6D – Flow rate, maximum of each of last seven days: The maximum flow rate in gallons per minute that occurred in each of the last seven days will be displayed. Press ▲ arrow to display maximum flow rate today = 0, yesterday = 1. This display will equal zero if a water meter is not installed. Press the NEXT button to go to Step 7D. Press REGEN to return to the previous step.

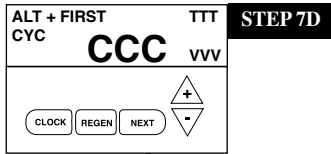

STEP 7D

STEP 7D – MAV Drive History – Not displayed if MAV set to off.

- First - Average of 1st three drive times of MAV in that direction
 - Last - Last drive time measured for that MAV in that direction
 - Ave - Average drive time measured for MAV in that direction
 - TTT - Drive time (1424 = 14.24 seconds)
 - CCC - Total number of cycles for that MAV
 - VVV - Relative drive voltage
- MAV drives piston "in" is designated by (-) sign.
MAV drives piston "out" is designated by (+) sign.

RETURN TO NORMAL MODE

Any time MAV is rebuilt or replaced, reset diagnostics to reflect new drive characteristics.

VALVE HISTORY (Can not be reset)

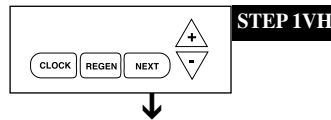

STEP 1VH

STEP 1VH – Press ▼ and ▲ simultaneously for three seconds and release, then press ▼ and ▲ simultaneously and release. If screen in step 2VH does not appear in 5 seconds the lock on the valve is activated.

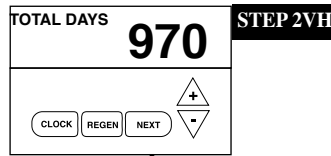

STEP 2VH

STEP 2VH – Days, total since start-up: This display shows the total days since startup. Press the NEXT button to go to Step 3VH. Press REGEN to return to previous step.

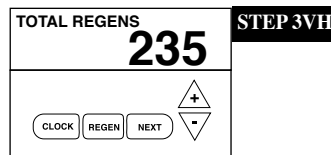

STEP 3VH

STEP 3VH – Regenerations, total number since start-up: This display shows the total number of regenerations that have occurred since startup. Press the NEXT button to go to Step 4VH. Press REGEN to return to previous step.

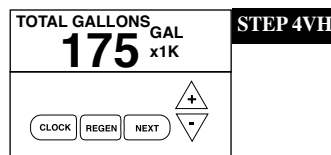

STEP 4VH

STEP 4 VH – Volume, total used since start-up: This display shows the total gallons treated since startup. This display will equal zero if a water meter is not installed. Press NEXT button to exit Valve History. Press REGEN to return to previous step.

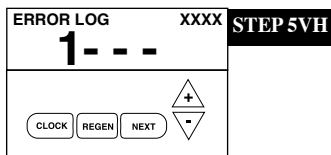

STEP 5VH

STEP 5 VH – Error Log history: up to 10 errors. Press ▼ and ▲ buttons to view each recorded error. If no errors have occurred " - - - - " is displayed. With STALL ERRORS 102, 107, 117, right upper corner of display indicates piston position at time of stall. Press NEXT to exit valve history.

RETURN TO ROTATING DISPLAY

CYCLE SEQUENCE

Anytime cycle sequence is modified, softener set-up will revert to manufacturer setting and must be reprogrammed as desired.

Cycle Sequence instructions allows the operator to set the order of the cycle. The Softener System Setup allows the operator to set how long the cycles will last. The operator may choose up to 9 cycles in any order.

Cycle Options		
BACKWASH	REGENERANT DRAW-DN	FILL
RINSE	SOFTENING	END

END must be used as the last cycle option. The SERVICE cycle should only be used in brine prefill applications to allow salt to dissolve.

The following is an example of how to set a valve so that when regeneration is initiated, BACKWASH occurs first, REGENERANT DRAW DN occurs second, RINSE occurs third, and FILL occurs fourth.

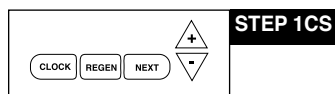

STEP 1CS – Press NEXT and ▼ simultaneously until TYPE appears on screen and release. Then press NEXT and ▼ simultaneously again for 3 seconds and release. If screen in step 2CS does not appear in 5 seconds the lock on the valve is activated.

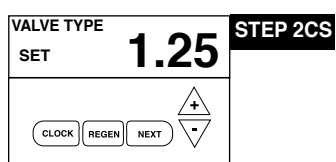

STEP 2CS – Valve Type. Use the ▲ or ▼ to select from 1.0", 1.25", 1.50", 2.0L", 2.0" valve. H125 is a 1.25" meter. Press NEXT to go to Step 3CS.

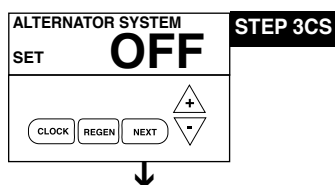

STEP 3CS – Use the ▲ or ▼ to select one of the following:

- Twin Alternating System – Select Alt A or Alt B, See instructions in Step 4CS; or
- System Controller Enabled - Allows Demand Recall Programming – See instructions in Step 9CS.
- No Hard Water Bypass During Regeneration – See instructions in Step 6CS.
- Reclaim Enabled - Allows control to operate in Reclamation Mode – See instructions in Step 8CS.
- Separate Source Enabled - Allows control to have a separate water source during the regeneration cycle. See instructions in Step 7CS.
- OFF; **Factory Setting is OFF** - Press NEXT to go to Step 10CS.

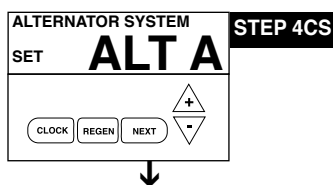

STEP 4CS –Twin Alternating System – Allows automatic alternation between two units to provide softened water 24 hours a day. Use ▲ or ▼ buttons to select ALT A or ALT B. Select ALT A for the control valve that has the two-pin connector labeled MAV DRIVE connected to the alternator valve. Select ALT B for the control valve that will be connected via three-prong connector labeled INTERCONNECT. Must use 3-wire interconnect cable. Press NEXT to go to Step 5CS.

For Alternating System, change programming:

- Set softener, with volume capacity in GALLONS and select Regeneration Time Option "IMMEDIATE" or "DELAYED" and select DAYS BETWEEN REGEN as desired.
- For complete programming, see Twin Alternating MAV manual.

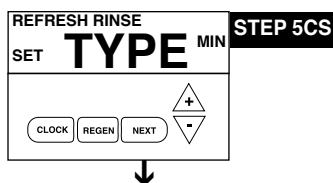

STEP 5CS – Select Twin Alternating Option.

- Use ▲ or ▼ buttons to select
- Standard - Standard Alternating Function
 - Refresh Rinse - Alternates every 6am & 6pm and runs programmable number of gallons to service. Press NEXT to set number of gallons.
 - Delayed Rinse and Fill- See below
 - **Factory Setting is Standard Alternating Function**

This option delays the last two cycles of regeneration (only "Rinse" and "Fill"). This feature splits the regeneration into two portions. The first portion of the regeneration will start immediately and all programmed cycles before the "Rinse" and "Fill" cycles will be performed. After all programmed cycles before "Rinse" and "Fill" are completed the control valve will drive to the service position (displaying "Delayed Rinse + Fill Pending"). When the volume of the on-line unit is depleted to 10% of its programmed capacity, the control valve will be triggered to finish the second portion of the regeneration and complete the "Rinse" and "Fill" cycles and return to Service and be placed into Standby mode, and wait to come on-line for service. Press NEXT to go to Step 10CS.

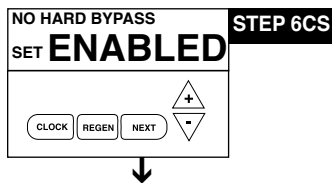

STEP 6CS – No Hard Water Bypass Enabled - Use ▲ or ▼ buttons to select NO HARD WATER BYPASS ENABLE. Selection requires that a connection to a Motorized Alternator Valve (MAV) is made to the two pin-connector labeled ALTERNATOR MAV DRIVE located on the printed circuit board. The MAV will be driven closed before the first regeneration cycle that is not FILL or SOFTENING or FILTERING, and be driven open after the last regeneration cycle that is not FILL. NOTE: If the control valve enters into an error state during regeneration mode, the no hard water bypass valve will remain in its current state until the error is corrected and reset. Reset by pushing NEXT & REGEN buttons simultaneously until display changes. Press NEXT to go to Step 10CS.

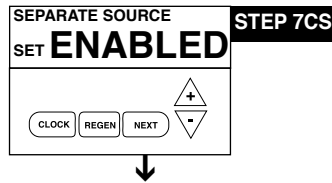

STEP 7CS – Configuring the Control Valve for Separate Source Operation - Select Separate Source Enabled for control operation. For separate source operation, the three wire connector is not used. Selection requires that a connection to a MAV is made to the two pin connector labeled ALTERNATOR MAV DRIVE located on the printed circuit board. The C port of the MAV must be connected to the valve inlet and the A port connected to the separate source used during regeneration. The B port must be connected to the feed water supply. When set to Separate Source Enabled the MAV will be driven closed before the first regeneration cycle, and be driven to open after the last regeneration cycle. NOTE: If the control valve enters into an error state during regeneration mode, the MAV will remain in its current state until the error is corrected and reset. Reset by pushing NEXT & REGEN buttons simultaneously until display changes.

WATER SOFTENER DRAINING PROCEDURE

In cold weather climates it is common for plumbing systems that are not in use to be “winterized” or drained of all water to prevent any damage that may be caused by the excessive expansion of water when it freezes. To prevent damage to a water softener it must be **properly** drained also. A simple way to properly drain or winterize a water softener is to use compressed air to force all of the water out of the softener mineral tank. The following procedure will explain the process:

- 1) Initiate the softener into a manual regeneration cycle. Advance control to backwash and allow it to complete the backwash cycle (this will clean the media) and start into the brine-draw cycle. Note: Be sure there is salt in the brine tank and water has been in contact with salt at least 20 minutes. Allow the regeneration to continue in the brine draw cycle until the brine is drawn out of the salt keeper and the air check at the bottom of the brine pick-up tube shuts off. At this time no more brine is introduced into the softener and the slow rinse process begins.
- 2) Turn the water supply inlet and outlet valves off to the water softener as soon as the air check shuts off and no more brine is being drawn into the softener (at the beginning of the slow rinse process).
- 3) Unplug the electric power leaving the softener control valve in the brine draw cycle.
- 4) Remove the brine refill elbow assembly from the control valve. Remove the refill flow control retainer assembly from the elbow. Reinstall the elbow assembly and secure with the locking clip. Disconnect the brine tube at the top of the salt keeper and force air into the brine tube toward the softener mineral tank and control valve. The air will force the brine/water solution that was drawn into the mineral tank out to drain through the control valve drain line. (An air compressor blow gun attachment with a portable air compressor works well.) Reinstall the brine line flow control retainer in side of the refill elbow assembly. Reinstall the brine refill elbow assembly and secure with locking clip.

CAUTION: You do not want to apply any more pressure than necessary to force the brine/water out of the mineral tank. The small amount of brine/water that may be left in the

mineral tank will not expand enough to cause any damage to the softener when it freezes.

If your softener is equipped with an optional bottom drain on the mineral tank, you will have to follow all of the same procedures with the exception of the need for compressed air. With the brine tube disconnected from the salt keeper, raise it to a level above the softener control valve and temporarily secure it in this position. Now open the drain valve at the bottom of the mineral tank and allow all brine/water to drain from the mineral tank.

CAUTION: If a hose is connected to the drain valve to direct the brine/water to a floor drain be sure it runs downward and is unobstructed. When brine/water quits running at the drain, be sure to leave the drain valve open until you start the system up again.

- 5) At this time the salt keeper has very little water left in it. What liquid is left in the salt keeper is saturated brine, provided that there is still salt left in the tank. Saturated brine will not freeze solid and cause any damage and does not have to be drained any further from the brine tank.

If there is no salt left in the salt keeper when the system is drained we recommend dumping all of the water out of the brine tank at this time. See brine tank cleaning instructions. (#2 in miscellaneous section, below)

- 6) **CAUTION:** It is important at this time to be assured that the inlet/outlet water supply piping is properly drained. Depending on how the water supply piping was routed to the water softener control valve, a water loop or trap may have been created.

Sometimes drain valve(s) are installed at the bottom of the loop to assure all water can be drained out. If not it may be necessary to disconnect the control valve from the piping system and open the inlet/outlet valve(s) to allow all the water to drain from the piping. This should be done when the rest of the plumbing system is drained.

- 7) Draining or winterizing of your softener is complete. Refer to the start-up procedures on page 7 when you are ready to start your softener.

MISCELLANEOUS

1. Salt Usage: See your water conditioning professional for a recommendation on the best type of salt for your application.
2. Brine Tank Cleaning:
 - a. Remove brine tank cover.
 - b. Scoop out as much old salt as possible.
 - c. Disconnect brine tubing from safety brine valve at brine well.
 - d. Remove safety brine valve from brine well.
 - e. Place one hand in brine well to hold overflow nut and remove 2 piece overflow.
 - f. Remove optional brine well and grid plate, if used, from brine tank.
 - g. Remove any remaining salt and/or impurities from brine tank.
 - h. Using clean water and a brush or rag, wipe and rinse inside of brine tank. Also wipe and rinse the grid plate and brine well.
 - i. Reassemble brine tank reversing steps c - f. Note: If grid plate is used and it is damaged or cracked, replace with new one.
 - j. Put brine tank in place making sure there is no debris or foreign material beneath it.
 - k. Reconnect brine tubing to safety brine valve.
 - l. Manually add 6 inches of water to the brine tank (or to approximately 1” above the grid plate, if used).
 - m. Add new salt. Important: Do not add the old salt which was removed earlier unless it is clean and not mushy. We recommend using new salt.
 - n. Follow the disinfection instructions found on page 5.
 - o. Put on brine tank cover.

TROUBLE SHOOTING

PROBLEM	CAUSE	CORRECTION
<p>After resolving the cause of any error code or any service work on valve, press NEXT & REGEN simultaneously for 5 seconds or disconnect power supply for 5 seconds at PC board and reconnect to resynchronize software with piston position.</p>		
<p>VALVE ERROR CODES</p>		
<p>Error Code 101 - Unable to recognize start of regeneration</p>	<p>A1. Control not reading piston position</p>	<p>A1. Resynchronize software with piston position by pressing start of regeneration NEXT and REGEN buttons simultaneously for 5 seconds, until screen changes. Initiate regeneration to verify function by pressing and holding REGEN button until regeneration initiates, step through regeneration modes by pushing REGEN button each time motor stops.</p> <p>A2. Verify motor connection to PC board; motor wires intact and motor fully inserted to engage pinion.</p> <p>A3. Verify correct assembly; PC board snapped onto drive bracket and wires are in back plate guides and drive bracket snapped onto back plate. Verify three drive gears are in place on drive bracket & reflective surfaces are clean.</p>
<p>Error Code 102 - Unexpected stall</p>	<p>B1. Mechanical Binding</p> <p>B2. Improper voltage being delivered to board</p>	<p>B1a. Check for any foreign material in stack assembly impeding piston movement and remove; verify seals intact and in place in stack assembly, if not replace stack assembly.</p> <p>B1b. Check for incorrect assembly, drive bracket not snapped into place, motor pushed inside of barrel of drive bracket (black gear on motor end should be flush with end of shaft).</p> <p>B1c. Drive gears unable to rotate freely - replace gear(s) if not rotating freely.</p> <p>B2. Motor unable to move piston, check voltage is present on 12V DC motor at start of regeneration modes. Transformer should provide 12 volts when plugged into outlet and not attached to board - if not replace transformer</p>
<p>Board does not have LED display</p>	<p>1. Transformer unplugged</p> <p>2. No electric power at outlet</p> <p>3. Defective transformer</p> <p>4. Low battery after power outage</p>	<p>A1. Plug transformer into uninterrupted power supply, verify power connection is plugged into 4-prong connection on PC board</p> <p>B1. Repair outlet or use working outlet, should read 115V with voltmeter at outlet. Verify power cannot be turned off with another switch</p> <p>C1. Check voltage at connection with transformer plugged in. Should read >12 volt AC with voltmeter. Replace transformer if inadequate voltage</p> <p>D1. If power outage occurred and battery on board has low voltage, the microprocessor may not recover cleanly and display properly. Disconnect power from circuit board and remove battery, wait 5 minutes. Reconnect power, if displays appropriately, replace battery (lithium CR2032). If you do not have battery at time of evaluation, leave battery out of board, only concern will be time of day reset will be needed if power outage occurs again. Voltage on battery should be > than 3 volts</p>
<p>MAV ERROR CODES</p>		
<p>After resolving any MAV error or servicing MAV, resynchronize software with piston positioning by pressing NEXT and REGEN buttons simultaneously for 5 seconds or disconnecting power from PC board for 5 seconds and reconnecting.</p>		
<p>ALTERNATING MAV DRIVE - ERROR CODES 106 & 107</p>		
<p>Error Code 106 - Alternating MAV ran too long</p>		<p>A1. Control valve is programmed for alternating or as NHWB without having MAV connected to board. Reprogram valve to proper setting or connect MAV to alternating MAV drive on PC board</p> <p>A2. MAV motor not fully engaged with gears</p>
<p>Error Code 107 - Alternating MAV stalled</p>	<p>Mechanical Binding</p>	<p>B1. Open MAV and check for foreign material on stack assembly, remove if present, verify seals intact and in place. If not, replace stack assembly</p> <p>B2. Drive gear should spin freely-replace if necessary</p>
<p>AUXILIARY MAV DRIVE - ERROR CODES 116 & 117</p>		
<p>Error Code 116 - Auxiliary MAV ran too long</p>		<p>A1. Control valve is programmed for auxiliary MAV without having MAV connected to board. Reprogram valve to proper setting or connect MAV to two-pin connection labeled auxiliary drive on PC board</p> <p>A2. MAV motor not fully engaged with gears</p>
<p>Error Code 117 - Auxiliary MAV stalled</p>	<p>Mechanical Binding</p>	<p>B1. Open MAV and check for foreign material on stack assembly, remove if present, verify seals intact and in place. If not, replace stack assembly</p> <p>B2. Drive gear and reducing gears should spin freely, replace if necessary</p>
<p>1. Control valve stalled in regeneration</p>	<p>A. Motor not operating</p> <p>B. No electric power at outlet</p> <p>C. Defective transformer</p> <p>D. Defective PC board</p> <p>E. Broken drive gear or drive cap assembly</p> <p>F. Broken piston retainer</p> <p>G. Broken main or regenerant piston</p>	<p>A. Replace Motor</p> <p>B. Repair outlet or use working outlet</p> <p>C. Replace transformer</p> <p>D. Replace PC board</p> <p>E. Replace drive gear or drive cap assembly</p> <p>F. Replace drive cap assembly</p> <p>G. Replace main or regenerant piston</p>

TROUBLE SHOOTING

PROBLEM	CAUSE	CORRECTION
2. Control valve does not regenerate automatically when REGEN button is depressed and held	<ul style="list-style-type: none"> A. Transformer unplugged B. No electric power at outlet C. Broken drive gear or drive cap assembly D. Defective PC board 	<ul style="list-style-type: none"> A. Connect transformer B. Repair outlet or use working outlet C. Replace drive gear or drive cap assembly D. Replace PC board
3. Control valve does not regenerate automatically but does when REGEN button is depressed	<ul style="list-style-type: none"> A. Bypass valve in bypass position B. Meter connection disconnected C. Restricted/stalled meter turbine D. Defective meter E. Defective PC board F. Programming error 	<ul style="list-style-type: none"> A. Put control valve in service position B. Connect meter to PC board C. Remove meter and check for free rotation or foreign matter D. Replace meter E. Replace PC board F. Check control valve set-up procedure
4. Time of day flashes on and off	<ul style="list-style-type: none"> A. Battery back-up maintains time-of-day up to 2 years in event of power outage and battery is not depleted. Time of day flashes when battery is depleted. B. Prior to 2/2007, PC board did not have battery back-up - capacitor held time of day up to 2 hours. Power outage > 2 hours. 	<ul style="list-style-type: none"> A. Reset time of day and replace battery on PC Board (Lithium coin type battery 2032) B. Reset time of day.
5. Softener delivers hard water.	<ul style="list-style-type: none"> A. Bypass valve is open or faulty. B. No salt or low salt level in brine tank. C. Softener fails to draw brine. D. Excessive water usage. E. Insufficient brine level in brine tank. F. Resin level inadequate. G. Meter faulty. H. Raw water hardness fluctuation. 	<ul style="list-style-type: none"> A. Close bypass valve or replace. B. Add salt to brine tank and maintain salt level above water level. C. See problem #10. D. Check gallon capacity settings. E. Check brine refill setting and refill flow restrictor for blockage. F. See problem #7. G. Test meter and clean or replace meter. H. Test raw water hardness and adjust settings to highest known hardness.
6. Unit uses too much salt.	<ul style="list-style-type: none"> A. Improper brine refill setting. B. Improper settings. C. Excessive water in brine tank. D. Leaking faucets, toilets, etc... E. Brine line flow control out of place 	<ul style="list-style-type: none"> A. Check brine refill setting for proper salt dosage B. Check water hardness and reevaluate capacity setting specification C. See problem #9. D. Repair or replace those items. E. Replace Brine line flow control.
7. Loss of resin.	<ul style="list-style-type: none"> A. Backwash controller missing. B. Faulty distributor tube assembly. C. Air being drawn in through brine system. D. Air in water supply system 	<ul style="list-style-type: none"> A. Install backwash controller. B. Check distributor tube assembly for cracks or holes. C. Check for leaks in brine lines, fittings, or air check. Repair or replace. D. <ul style="list-style-type: none"> 1. Install upper distributor if missing. 2. Ensure that water supply system has an air eliminator.
8. Softener delivers salty water.	<ul style="list-style-type: none"> A. Low water pressure. B. Excessive water in brine tank. C. Wrong size injector. 	<ul style="list-style-type: none"> A. Check incoming water pressure - Must remain at minimum of 25 psi. B. See problem #9. C. Install correct injector.
9. Excessive water in brine tank.	<ul style="list-style-type: none"> A. Plugged injector. B. Faulty piston/seal assembly. C. Plugged or kinked drain line. D. Backwash flow controller closed off. E. Defective brine line flow control. 	<ul style="list-style-type: none"> A. Remove injector and clean ports. B. Replace piston/seal assembly. C. Correct any kinking or plugging of drain line. D. Check backwash flow controller. E. Replace brine refill flow control.
10. Softener fails to draw brine.	<ul style="list-style-type: none"> A. Injector is plugged, absent/missing oring(s) B. Faulty piston assembly. C. Brine line connection leak. D. Drain line plugged creating excess back pressure. E. Drain line too long or too high. F. Low inlet pressure. 	<ul style="list-style-type: none"> A. Remove injector and clean ports/replace if necessary B. Check piston assembly. C. Inspect brine line during refill cycle for leaks. D. Inspect drain line for blockage. E. Refer to drain line specifications. F. Increase inlet pressure to a minimum of 25 psi.
11. Continuous flow to drain.	<ul style="list-style-type: none"> A. Piston assembly failure. B. Motor failure. C. Circuit board failure. 	<ul style="list-style-type: none"> A. Replace piston assembly. B. Replace motor. C. Replace circuit board.
12. Loss of water pressure.	<ul style="list-style-type: none"> A. Iron build-up in resin. B. Resin bed fouled with sand or sediment. C. Resin bed mushing due to high amount of oxidizers in water supply (chlorine). 	<ul style="list-style-type: none"> A. See problem #13, page 23. B. Rebed softener and install sediment filter ahead of softener. C. Rebed softener. Install dechlorination system ahead of softener

TROUBLE SHOOTING

PROBLEM	CAUSE	CORRECTION
13. Iron in softened water.	A. Iron has fouled resin bed. B. Iron is not in a soluble state. C. Prefilter failure. D. Iron level excessive. E. Control fails to regenerate.	A. Use iron reducing resin cleaner to clean resin bed, and increase salt dosage or regenerate more frequently or rebed softener. Install an Iron Curtain System ahead of the softener. B. Test water to determine type of iron, install iron reduction system. C. Check prefilter. D. Install iron reduction system. E. See problem #3, page 22.
14. Absent or incomplete LED display	A. Transformer unplugged B. No electric power at outlet C. Defective transformer D. Short in meter E. Defective PC board	A. Plug transformer into uninterrupted outlet B. Repair outlet or use working outlet C. Replace transformer D. Unplug meter from PC board, if LED display lights appropriately, replace meter E. Replace PC board
15. Control does not display correct time of day	A. Power outage > 2 years B. Power outage < 2 years, time of day flashing, battery depleted	A. Reset time of day B. Replace lithium coin type battery on circuit board Model 2032 battery
16. No "softening" or "filtering" display when water is flowing	A. Bypass valve in bypass position B. Meter connection disconnected C. Restricted/stalled meter turbine D. Defective meter E. Defective PC board	A. Put bypass valve in service position B. Connect meter to PC board C. Remove meter and check for free rotation, clean foreign material D. Replace meter E. Replace PC board
17. Control valve regenerates at wrong time of day	A. Power outages > 24 hours B. Time of day not set correctly C. Time of regeneration incorrect D. Control valve set at "on 0" (immediate regeneration) E. Control valve set at NORMAL + on 0	A. Reset control valve to correct time of day B. Reset to correct time of day C. Reset regeneration time D. Check control valve set-up procedure regeneration time option (see page 33) E. Check control valve set-up procedure regeneration time option (see page 33)

RELAY TROUBLESHOOTING

PROBLEM	CAUSE	CORRECTION
18. Relay does not energize		
A. Relay driver programmed on "Time"	A. Programmed incorrectly B. Defective relay. See figure below C. Defective PC Board D. Faulty wire connections between PC board and relay	A. Reprogram, see page 11-12 B. Replace Relay C. Replace PC Board D. Check and repair wire connections
B. Relay driver programmed on "Gallons"	A. Programmed incorrectly B. Faulty meter connection C. Defective relay. See figure below D. Defective PC Board E. Faulty wire connections between PC board and relay	A. Reprogram, see page 11-12 B. Repair or replace meter assembly C. Replace Relay D. Replace PC Board E. Check and repair wire connections
19. Relay energized when water used in service and during regeneration	A. Relay programmed as "on REGEN gallons"	A. Reprogram, see page 11-12.

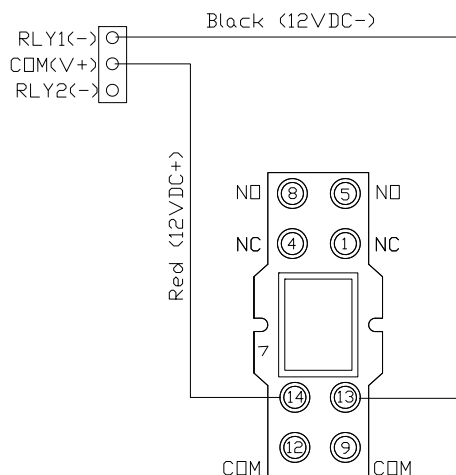

Relay operation while in error modes

1. Relays should turn off immediately whenever a Valve Error occurs.
2. Relays should remain on and continue to operate as programmed if a MAV Error (106/107 or 116/117) occurs and the valve has already entered regen.
3. Relays should remain off, and not operate as programmed, if a MAV Error (106/107 or 116/117) occurs and the valve has not entered regeneration.
4. Lockout - Relay remains active during error, power outage and manual advance through regeneration cycles.

H125 CONDITIONER & BRINE TANK ASSEMBLIES

Item	Description	Qty	Part #
1	Control Center-Metered	1	104226 (see pages 25-26 for detailed components)
2	Top Diffuser	1	101540
3&4	Mineral Tank Assembly		<u>Item 3 only</u> <u>Item 4 only</u> Mineral Tank Distributor Assy
	H125-32-10 10 x 44	1	104546 101515
	H125-48 10 x 54	1	104552 101515
	H125-64 13 x 54	1	104577 101515
	H125-96 14 x 65	1	104580 101515
	H125-128 16 x 65	1	104583 103514 / H&L
	H125-160 18 x 65	1	104585 103515 / H&L
5	Ion Exchange Resin	*	101123 Standard 8% Resin *See Specifications for amount
		*	101113 Premium 10% Resin *See Specifications for amount
6	Underbedding or Plate Distributor	*	100983 *See Specifications for amount
7	3/8" x 6' Brine Line	1	102671
7-15 a	18X40 w/474 SBV & 5" Grid	1	104419
b	18X40 w/474 SBV & 8" Grid	1	104421
c	18X40 w/474 SBV & 11" Grid	1	104423
d	24x41w/474 SBV & 6" Grid	1	104425
e	24x50 w/474 SBV & 6" Grid	1	104428
f	24x50 w/474 SBV & 9" Grid	1	104423
g	18x40 w/474 SBV & No Grid	1	104416
h	24x41 w/474 SBV & No Grid	1	104424
i	24x50 w/474 SBV & No Grid	1	104426
j	30x50 w/474 SBV & No Grid	1	3-S605-3
8 a	18x40 Salt Keeper Tank-Black	1	104492
b	24x41 Salt Keeper Tank-Black	1	104495
c	24x50 Salt Keeper Tank-Black	1	104497
d	30x50 Salt Keeper Tank-Black	1	104499
9	Cover 18" BT	1	101448
	Cover 24" BT	1	2-G2194
10-14 a	Safety Brine Valve Assy 41"		104172
b	Safety Brine Valve Assy 50"		104173
10	Cap, Brine Well-4"	2	101365
11*	Safety Brine Valve (Must be ordered complete)	1	101274
12	Float Assembly	1	101660
13	Air Check (474)	1	101181
14 a	Brine Well 40"-41"	1	102877
b	Brine Well 50"	1	102878
15	2-Piece Overflow	1	102217
16 a	Grid Plate 18" (optional)	1	101758
b	Grid Plate 24" (optional)	1	2-H002
-	Owners Manual	1	109122
-	Twin Brine Tank Tee	1	103660

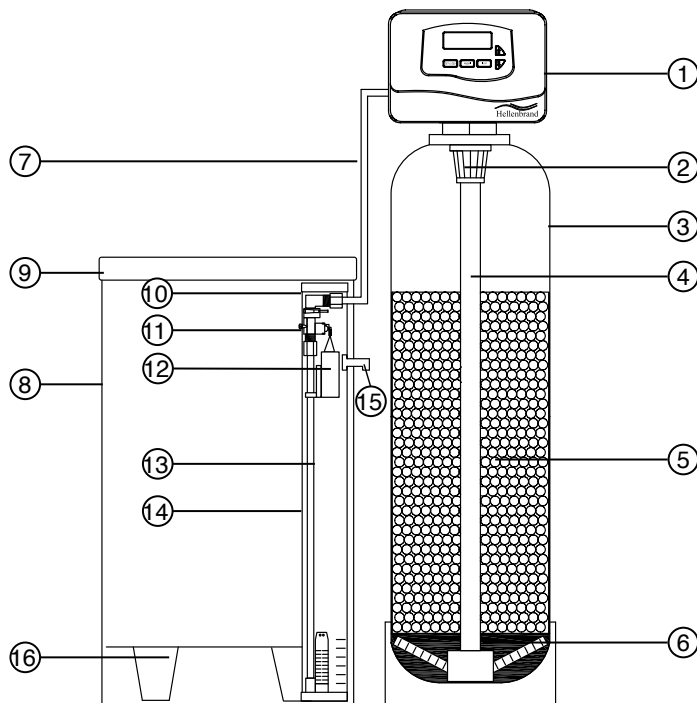

FRONT COVER AND DRIVE ASSEMBLY

DRAWING NO.	ORDER NO.	DESCRIPTION	QUANTITY
1	103462	Front Cover Assembly Black	1
2	102096	Motor Assembly	1
3	101262	Drive Bracket & Spring Clip	1
4	109807	H125 PC Board	1
5	101746	Drive Gear 12x36	3
6	101459	Drive Gear Cover	1
Not Shown	103723	Optional Relay Kit-PCM	1
Not Shown	103729	Optional Relay Kit-120V Pigtail	
Not Shown	101880	Auxiliary Switch Kit	
Not Shown	102653	Transformer 110V-12V	1

RELAY MODEL AND DESCRIPTION	
Relay Socket	102533 (2 pole socket)
Relay	102385 (12V DC DPDT magnetic relay)

Relay Specifications: To insure proper fit and correct operation the following relay and relay socket manufactured by Idec or the exact equivalent should be used.

WIRING FOR CORRECT ON/OFF OPERATION	
PC Board Relay Terminal Block	Relay Socket
RLY 1	#13
V+ (Center)	#14
RLY 2 (Bottom)	

The relay supplies 2 sets of dry contacts for user applications. The wiring of these contacts is application specific.

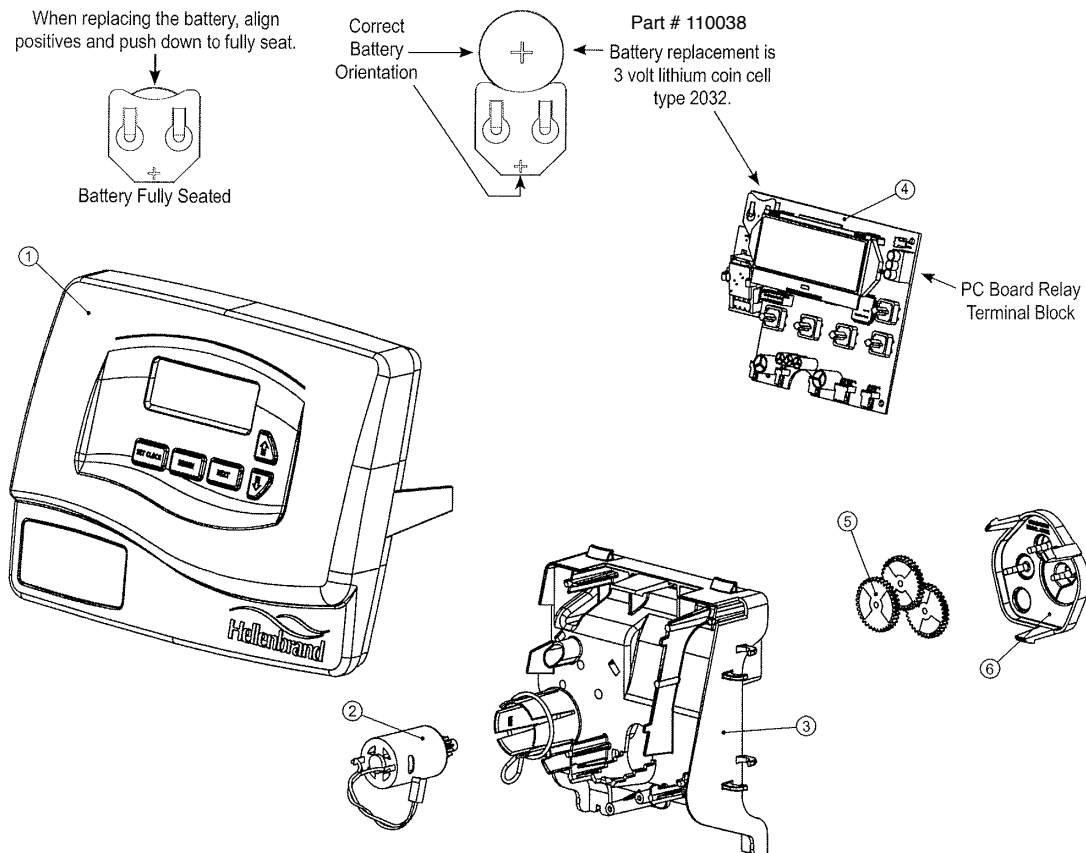

DRIVE CAP ASSEMBLY, DOWN FLOW PISTON, REGENERANT PISTON AND SPACER STACK ASSEMBLY

DRAWING NO.	ORDER NO.	DESCRIPTION	QUANTITY
1	102547	H125 Spacer Stack Assembly	1
2	101613	Drive Cap Assembly	1
3	101189	H125 Drive Back Plate	1
4	102291	H125 Piston Downflow Assy	1
5	102296	Regenerant Piston	1
6	102167	O-ring 228	1
7	102192	O-ring 337	1
8	102164	O-ring 219 (Dist. Tube Opening 1.32")	1

Note: The regenerant piston is not used in backwash only application.

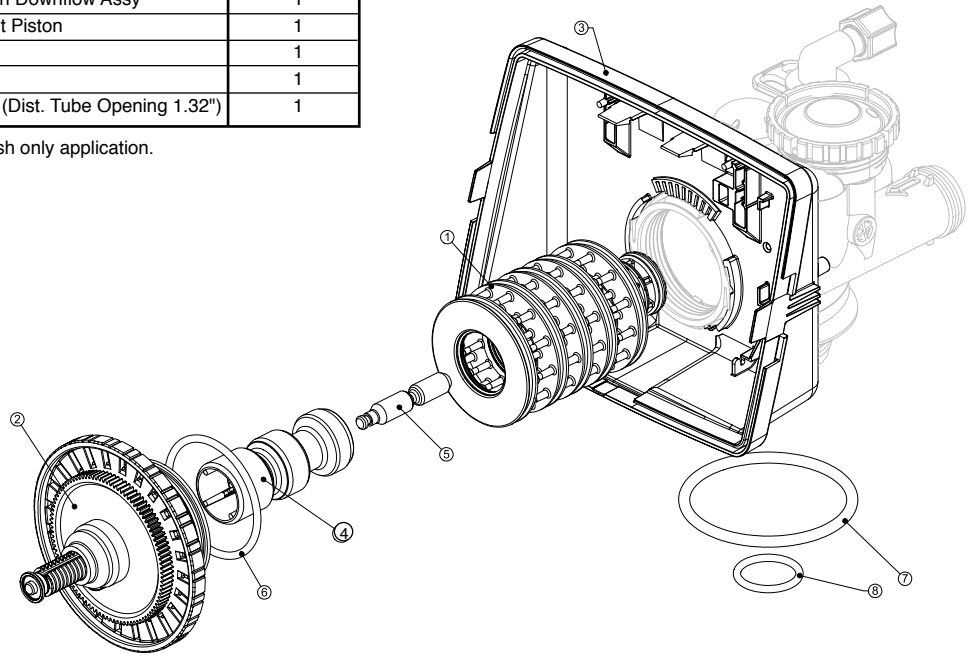

INJECTOR CAP, INJECTOR SCREEN, INJECTOR, PLUG AND O-RING

DRAWING NO.	ORDER NO.	DESCRIPTION	QUANTITY
1	101375	Injector Cap	1
2	102159	O-ring 135	1
3	102457	Injector Screen	1
4	102319	Injector Assembly Z Plug	1
5	101825	Injector Assembly A Black	1
	101826	Injector Assembly B Brown	
	101827	Injector Assembly C Violet	
	101828	Injector Assembly D Red	
	101829	Injector Assembly E White	
	101830	Injector Assembly F Blue	
	101831	Injector Assembly G Yellow	
	101832	Injector Assembly H Green	
	101833	Injector Assembly I Orange	
	101834	Injector Assembly J Light Blue	
101835	Injector Assembly K Light Green		
Not Shown	106767	O-ring 011	
Not Shown	106768	O-ring 013	

*The injector plug and the injector each contain one 011 (lower) and 013 (upper) o-ring.

Note: For upflow position, injector is located in the up hole and injector plug is in the other hole. H125 upflow bodies are identified by having the DN marking removed. For a filter that only backwashes, injector plugs are located in both holes.

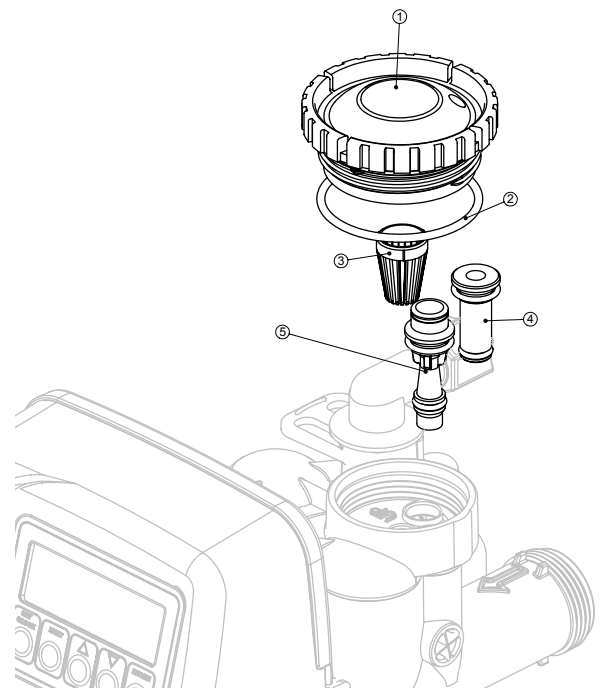

REFILL FLOW CONTROL ASSEMBLY AND REFILL PORT PLUG

3/8" – for systems up to 150,000 grains

(*Assembly includes #6. **This part is required for backwash only systems)

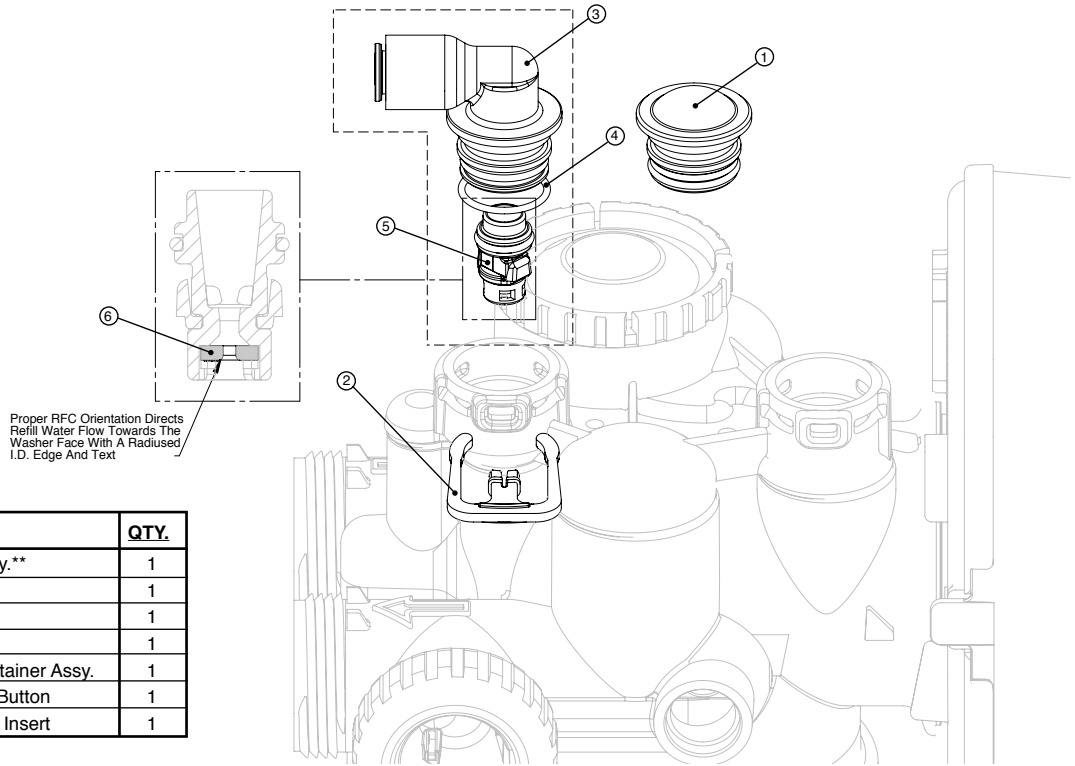

ITEM NO.	ORDER NO.	DESCRIPTION	QTY.
1	102322	Refill Port Plug Assy.**	1
2	101414	Elbow Locking Clip	1
3	111389	Elbow 3/8" LiquiFit	1
4	102153	O-ring 019	1
5	102418*	Refill Flow Cntrl Retainer Assy.	1
6	102421	Refill Flow Control Button	1
Not Shown	101617	1/2" Elbow w/Nut & Insert	1

REFILL FLOW CONTROL ASSEMBLY AND REFILL PORT PLUG

1/2" – for systems 150,000 grains and larger

(*This part is required for backwash only systems)

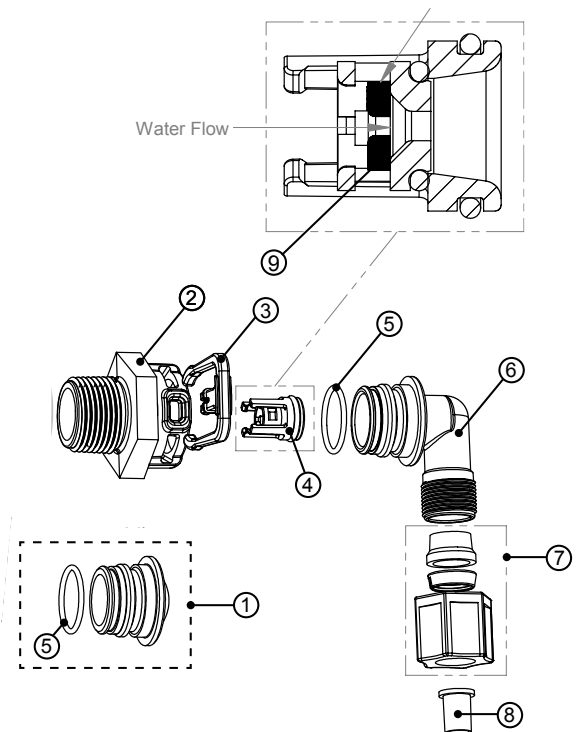

DRAWING NO.	ORDER NO.	DESCRIPTION	QUANTITY
1	102322	H125/H150 Refill Port Plug Assy**	1
2	101154	H125/H150 BLFC Adapter	1
3	101414	Locking Clip	1
4	102417	H125/H150 Refill Retainer Assy	1
4-8	103590	1/2" Refill Elbow Assy	1
5	102153	O-Ring 019	1
6	101617	Elbow Cap 1/2" Assy	1
7	102129	Nut Compression 1/2" Black	1
8	101869	Insert Polytube 1/2"	1
9	102421	H125/H150 RFC 0.5 GPM	1

DRAIN LINE - 3/4"

ITEM NO.	ORDER NO.	DESCRIPTION	QTY.
1	101414	Elbow Locking Clip	1
2	101871	Polytube Insert, 5/8"	Optional
3	102131	Nut 3/4" Drain Elbow	Optional
4-6	101619	Drain Elbow 3/4" Male Assy-No Vent	1
5	102153	O-ring 019	1
6	102406	DLFC Retainer Assy.	1
7	101551	DLFC 0.7 gpm for 3/4"	One DLFC must be used if 3/4 fitting is used
	101552	DLFC 1.0 gpm for 3/4"	
	101556	DLFC 1.3 gpm for 3/4"	
	101559	DLFC 1.7 gpm for 3/4"	
	101574	DLFC 2.2 gpm for 3/4"	
	101577	DLFC 2.7 gpm for 3/4"	
	101583	DLFC 3.2 gpm for 3/4"	
	101588	DLFC 4.2 gpm for 3/4"	
	101591	DLFC 5.3 gpm for 3/4"	
	101593	DLFC 6.5 gpm for 3/4"	
	101595	DLFC 7.5 gpm for 3/4"	

Systems are shipped without 3/4" nut for drain elbow (polytube installation only) and 5/8" polytube insert (polytube installation only).

See System Specifications DLFC on page 39, for correct DLFC size for your unit.

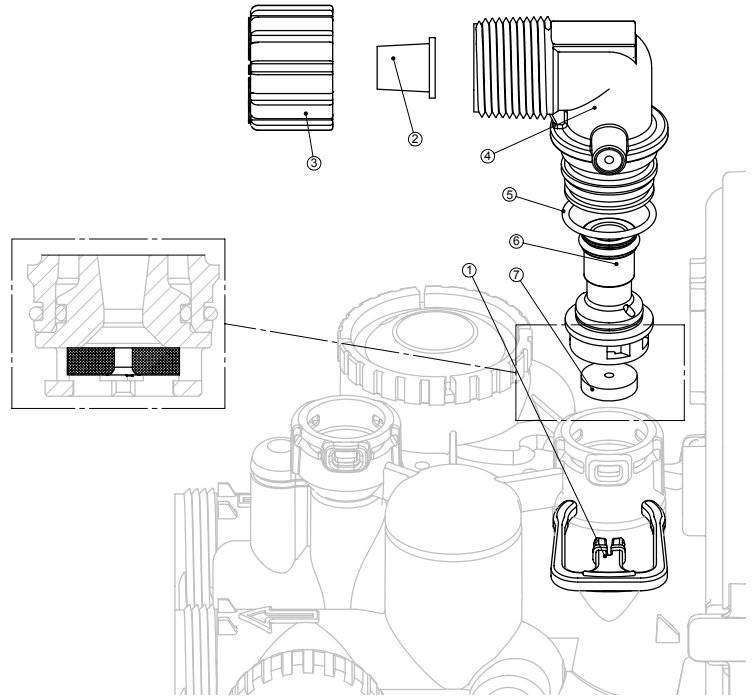

Figure 18

DRAIN LINE - 1"

ITEM NO.	ORDER NO.	DESCRIPTION	QTY.
1	101414	Elbow Locking Clip	1
2-8	101636	Drain Ftg 1" Straight Assy-No Vent	1
3*	101244	Drain Ftg Body, 1"	1
4*	101160	Drain Ftg Adapter, 1"	1
5*	102153	O-ring 019	1
6*	102437	Split Ring	1
7*	102141	Nut, 1" QC	1
8*	102165	O-ring 215	1
9	101599	DLFC 9.0 gpm for 1"	One DLFC must be used if 1" fitting is used
	101562	DLFC 10.0 gpm for 1"	
	101564	DLFC 11.0 gpm for 1"	
	101567	DLFC 13.0 gpm for 1"	
	101568	DLFC 15.0 gpm for 1"	
	101571	DLFC 17.0 gpm for 1"	
	101578	DLFC 20.0 gpm for 1"	
	101580	DLFC 25.0 gpm for 1"	

See System Specifications DLFC on page 39, for correct DLFC size for your unit.

The nuts and caps are designed to be unscrewed or tightened by hand or with the special plastic wrench. If necessary a pliers can be used to unscrew the nut or cap. Do not use a pipe wrench to tighten or loosen nuts or caps. Do not place screwdriver in slots on caps and/or tap with a hammer.

Do not use vaseline, oils, other hydrocarbon lubricants, or spray silicone anywhere. Teflon tape must be used on threads of the 1" NPT connection and on the threads for the drain line connection. Teflon tape is not necessary on the nut connection nor caps because of o-ring seals.

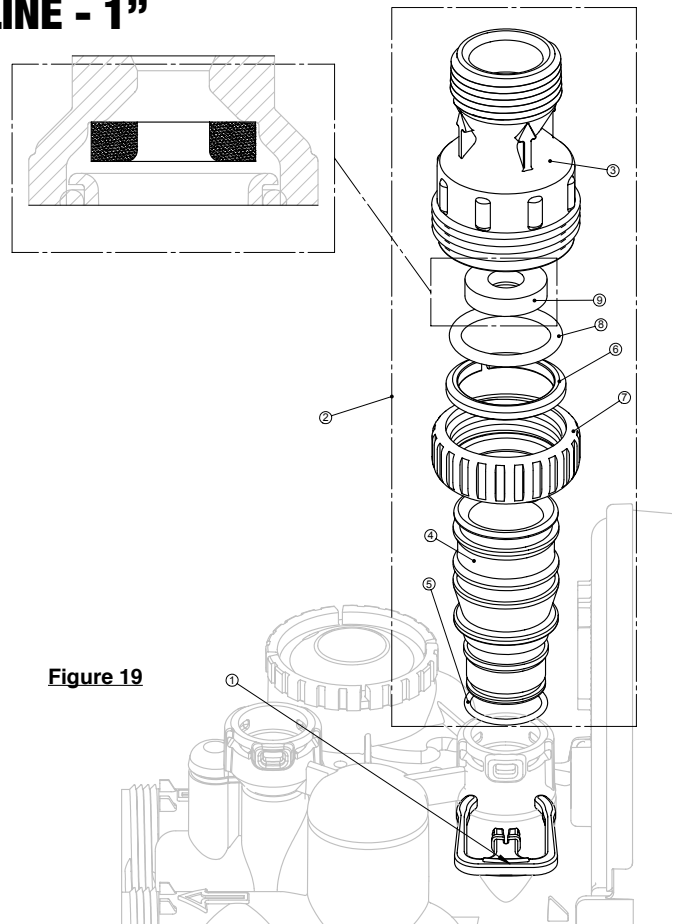

Figure 19

WATER METER AND METER PLUG

ITEM NO.	ORDER NO.	DESCRIPTION	QTY.
1	102141	Nut 1" QC	1
2-4	102051*	Meter Assy.	1
3	102687	Turbine Assy.	1
4	102165	O-ring 215	1
5	102321	Meter Plug Assy.**	1

*Order number 102051 includes 102687 and 102165, which are item numbers 3 & 4.

**Only used if metering is not to be done (time clock units)

The nuts and caps are designed to be unscrewed or tightened by hand or with the special plastic wrench. If necessary a pliers can be used to unscrew the nut or cap. Do not use a pipe wrench to tighten or loosen nuts or caps. Do not place screwdriver in slots on caps and/or tap with a hammer.

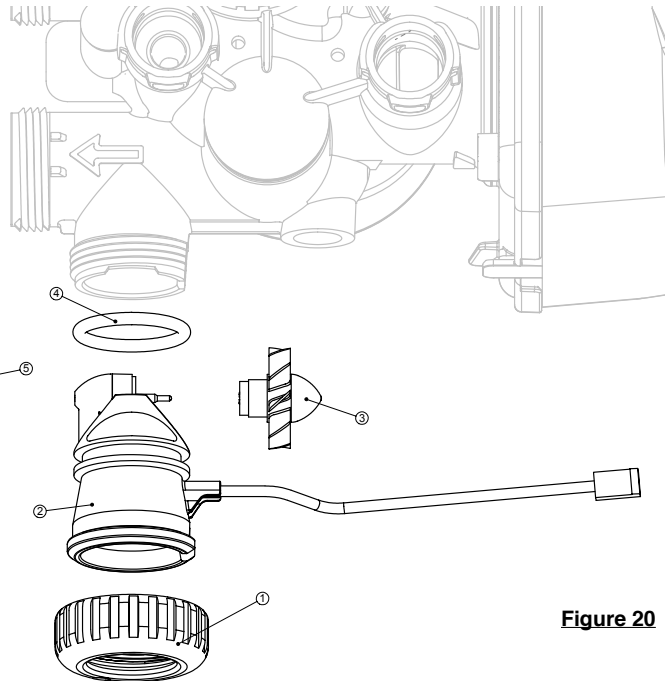
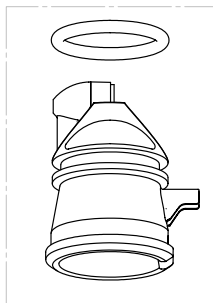

Figure 20

BYPASS VALVE

Bypass Valve

ITEM NO.	ORDER NO.	DESCRIPTION	QTY
1	102141	Nut 1" Quick Connect	2
2	102437	Split Ring	2
3	102165	O'Ring 215	2
4	102450	Bypass 1" Rotor	2
5	110997	Bypass Cap	2
6	110998	Bypass Handle	2
7	109479	Bypass Rotor Seal Retainer	2
8	102159	O-Ring 135	2
9	102161	O-Ring 112	2
10	102160	O-Ring 214	2

(Not Shown) Bypass Vertical Adapter Assembly

ORDER NO.	DESCRIPTION	QTY
102141	Nut 1" Quick Connect	2
102437	Split Ring	2
102165	O'Ring 215	2
106858	Bypass Vertical Adapter	2

The nuts and caps are designed to be unscrewed or tightened by hand or with the special plastic wrench. If necessary a pliers can be used to unscrew the nut or cap. Do not use a pipe wrench to tighten or loosen nuts or caps. Do not place screwdriver in slots on caps and/or tap with a hammer.

Do not use pipe dope or other sealants on threads. Teflon tape must be used on threads of the 1" NPT connection and on the threads for the drain line connection. Teflon tape is not necessary on the nut connection nor caps because of o-ring seals.

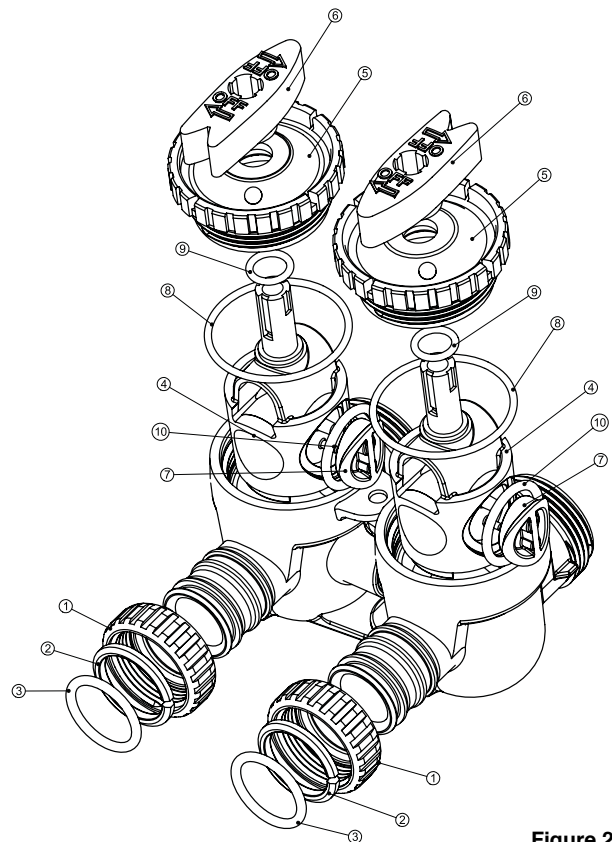
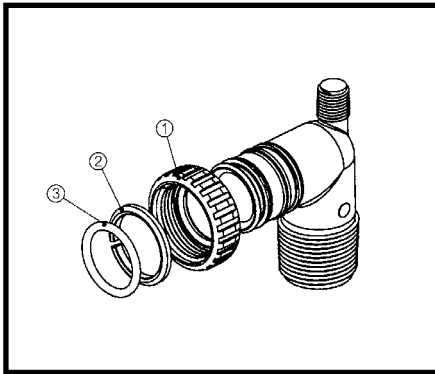
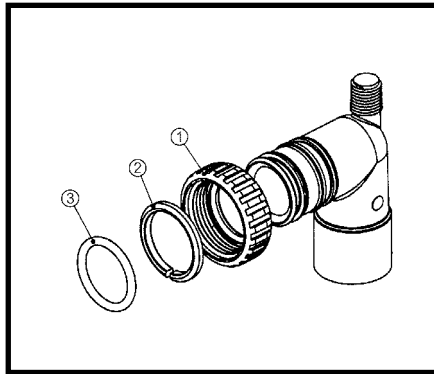

Figure 21

INSTALLATION FITTING ASSEMBLIES



101639 - Fitting 1" PVC Male NPT



101640 - Fitting 3/4" & 1" PVC Solv 90

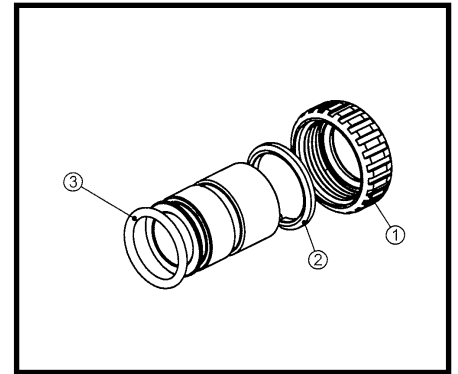

108618 - Fitting 1" Brass Sweat

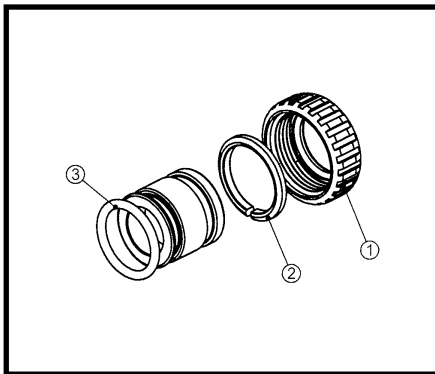

108617 - Fitting 3/4" Brass Sweat

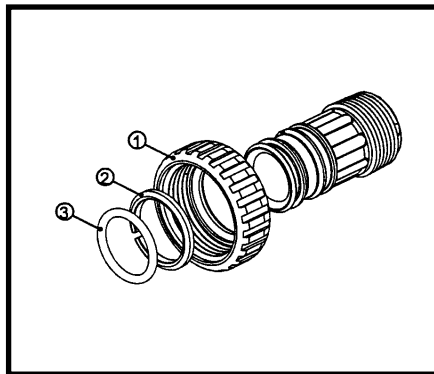

101643 - Fitting 1" Male NPT

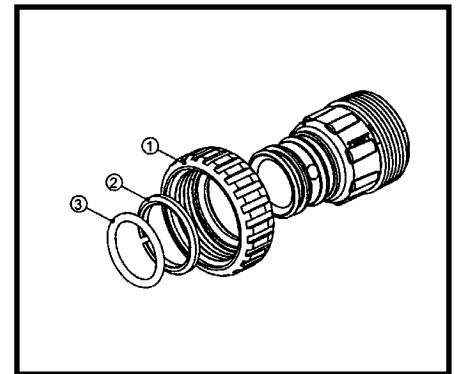

101644 - Fitting 1-1/4" Male NPT

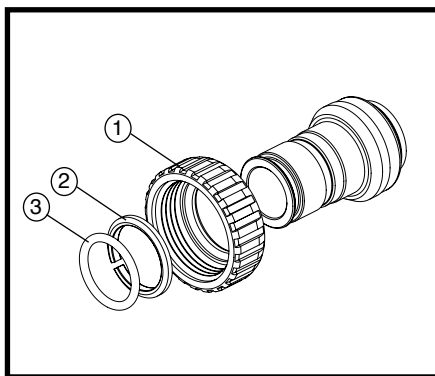

110136 - Fitting 1" Brass Sharkbite

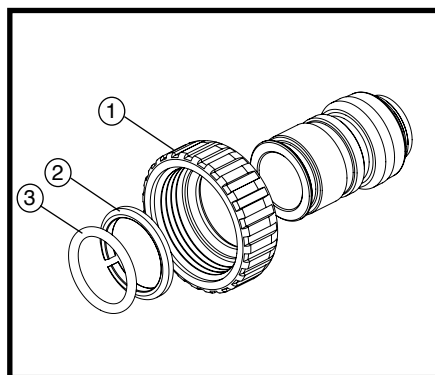

110135 - Fitting 3/4" Brass Sharkbite

ITEM NO.	ORDER NO.	DESCRIPTION
1	102141	Nut 1" Quick Connect
2	102437	Split Ring
3	102165	O-Ring 215

The nuts and caps are designed to be unscrewed or tightened by hand or with the special plastic wrench. If necessary a pliers can be used to unscrew the nut or cap. Do not use a pipe wrench to tighten or loosen nuts or caps. Do not place screwdriver in slots on caps and/or tap with a hammer.

Do not use vaseline, oils, other hydrocarbon lubricants, or spray silicone anywhere. Teflon tape must be used on threads of the 1" NPT connection and on the threads for the drain line connection. Teflon tape is not necessary on the nut connection nor caps because of o-rings seals.

FLOW DIAGRAMS – SERVICE AND BACKWASH

flow diagram...service

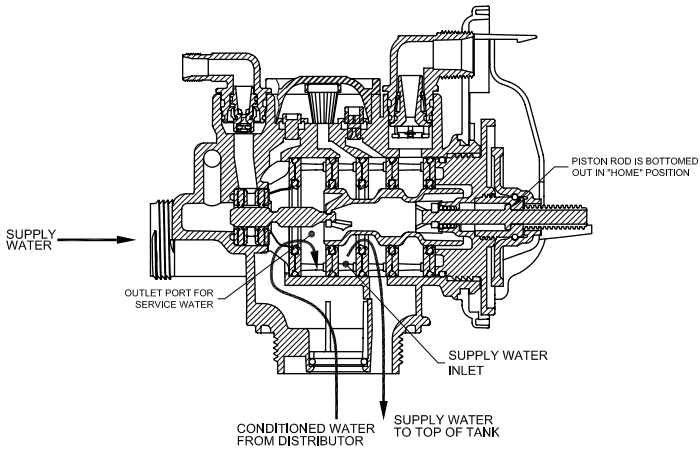

flow diagram...backwash

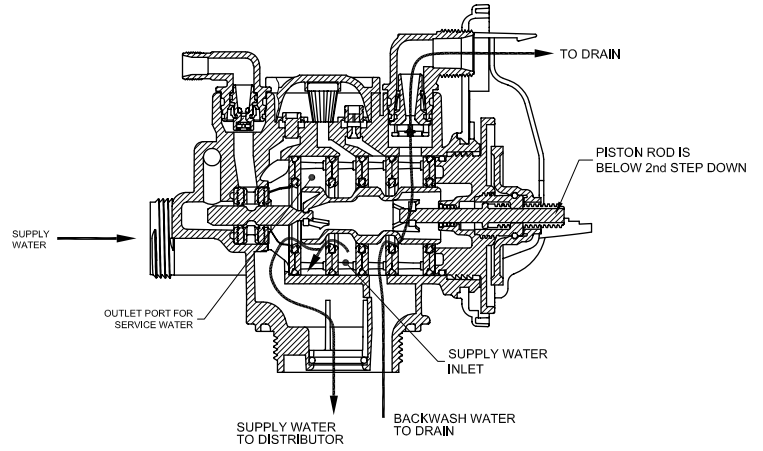

FLOW DIAGRAMS – RINSE AND FILL

flow diagram...rinse

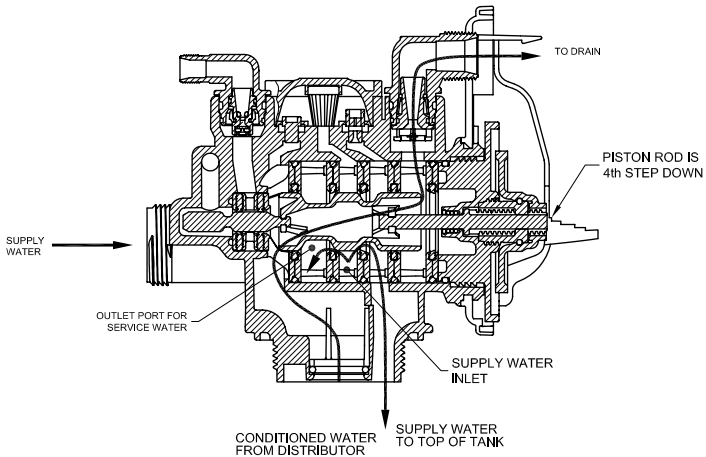

flow diagram...fill

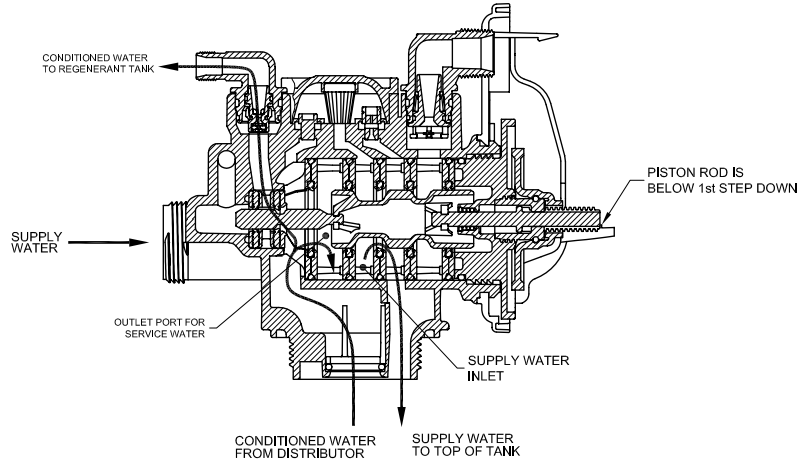

FLOW DIAGRAMS – DOWNFLOW

flow diagram...downflow brine

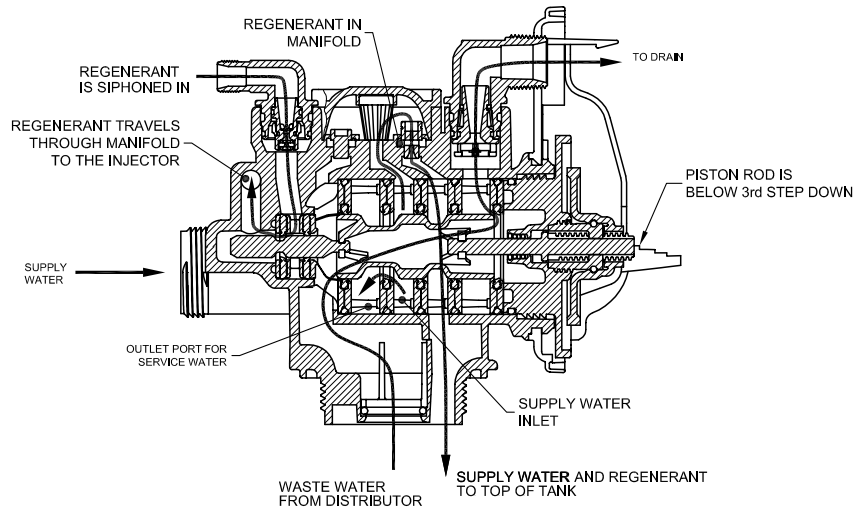

WRENCH

Although no tools are necessary to assemble or disassemble the valve, the wrench (shown in various positions on the valve) may be purchased to aid in assembly or disassembly. **Wrench part number is 102892.**

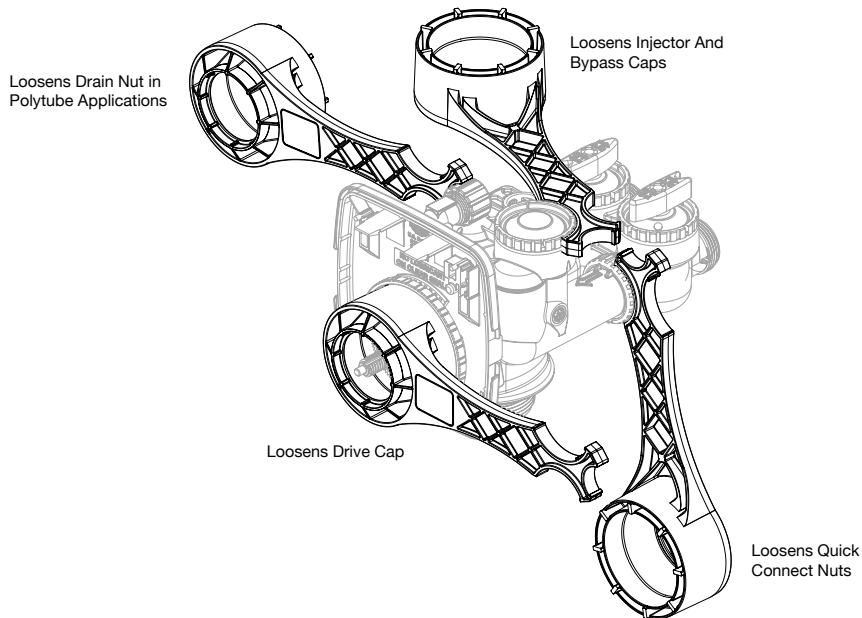

PROGRAMMING OPTIONS

Reserve Gallons	Regeneration Type	Days Override	Results (Reserve capacity estimate based on history of water usage)
AUTO	DELAY	oFF	Reserve capacity automatically estimated. Regeneration occurs when gallons capacity falls below the reserve capacity at the next Regen Set Time.
AUTO	DELAY	1 to 28	Reserve capacity automatically estimated. Regeneration occurs at the next Regen Set Time when gallons capacity falls below the reserve capacity or the specified number of days between regenerations is reached.
20 to 250,000	DELAY	oFF	Reserve capacity <u>not</u> automatically estimated. Regeneration occurs at the next Regen Set Time when gallons capacity reaches 0.
oFF	DELAY	1 to 28	Reserve capacity <u>not</u> automatically estimated. Regeneration occurs at the next Regen Set Time when the specified number of days between regenerations is reached.
20 to 250,000	DELAY	1 to 28	Reserve capacity <u>not</u> automatically estimated. Regeneration occurs at the next Regen Set Time when gallons capacity reaches 0 or the specified number of days between regenerations is reached.
AUTO	IMMEDIATE	oFF	Reserve capacity <u>not</u> automatically estimated. Regeneration occurs immediately when gallons capacity reaches 0. Time of regeneration will not be allowed to be set because regeneration will always occur when gallons capacity reaches 0.
20 to 250,000	DELAY + IMMEDIATE	oFF	Reserve capacity <u>not</u> automatically estimated. Regeneration occurs immediately when gallons capacity reaches 0. Time of regeneration will not be allowed to be set because regeneration will always occur on 0.
AUTO	DELAY + IMMEDIATE	oFF	Reserve capacity automatically estimated. Regeneration occurs when gallons capacity falls below the reserve capacity at the next Regen Set Time or regeneration occurs immediately after 10 minutes of no water usage when gallon capacity reaches 0.
AUTO*	DELAY + IMMEDIATE	1 to 28 *14	Reserve capacity automatically estimated. Regeneration occurs at the next Regen Set Time when gallons capacity falls below the reserve capacity or the specified number of days between regenerations is reached or regeneration occurs immediately after 10 minutes of no water usage when gallon capacity reaches 0.
20 to 250,000	DELAY + IMMEDIATE	1 to 28	Reserve capacity <u>not</u> automatically estimated. Regeneration occurs at the next Regen Set Time when specified number of days between regenerations is reached or regeneration occurs immediately after 10 minutes of no water usage when gallon capacity reaches 0.

***Factory settings in bold**

To "lockout" access to modification settings, diagnostic and valve history displays except hardness, day override and time, press ▾ next, ▲ and clock in sequence to "unlock" press ▾ next, ▲ and clock in sequence.

GENERAL SPECIFICATIONS

OPERATING PRESSURES

Minimum/Maximum25 psi-125 psi

OPERATING TEMPERATURES

Minimum/Maximum40° - 110° F

METER

Accuracy.....±5%
Flow Rate Range.....0.25 - 34 GPM
Gallon Range20 - 50,000

DIMENSIONS

Drain Line3/4" or 1" NPT
Brine Line3/8" Poly Tube

ELECTRICAL CURRENT DRAW AND VOLTAGE.....0.5A 110v

Compatible with the following regenerants or chemicals: Sodium chloride, potassium permanganate, sodium bisulfite, sodium hydroxide, hydroxide, hydrochloric acid, chlorine and chloramines.

SERVICE INSTRUCTIONS

Drive Assembly

Remove the valve cover to access the drive assembly.

Disconnect the power source plug (black wire) from the PC board prior to disconnecting the motor or water meter plugs from the PC board. The power source plug connects to the four-pin jack. The motor plug connects to the two-pin jack on the left-hand side of the PC board. The water meter plug (gray wire) connects to the three-pin jack on the far right-hand side of the PC board.

PC Board Replacement

The PC board can be removed separately from the drive bracket but it is not recommended. Do not attempt to remove the display panel from the PC board. Handle the board by the edges. To remove the PC board from the drive bracket, unplug the power, water meter and motor plugs from the PC board. Lift the middle latch along the top of the drive bracket while pulling outward on the top of the PC board. The drive bracket has two plastic pins that fit into the holes on the lower edge of the PC board. Once the PC board is tilted about 45° from the drive bracket it can be lifted off of these pins. To reinstall a board, push the top of the PC board towards the valve until it snaps under the middle latch, weave the power and water meter wires into the holders and reconnect the motor, water meter and power plugs.

Drive Bracket Replacement

The drive bracket must be removed to access the drive cap assembly and pistons or the drive gear cover. It is not necessary to remove the PC board from the drive bracket to remove the drive bracket. To remove the drive bracket start by removing the plugs for the power source and the water meter. Unweave the wires from the side holders. Two tabs on the top of the drive back plate hold the drive bracket in place. Simultaneously lift the two tabs and gently ease the top of the drive bracket forward. The lower edge of the drive bracket has two notches that rest on the drive back plate. Lift up and outward on the drive bracket to disengage the notches.

To reassemble, seat the bottom of the drive bracket so the notches are engaged at the bottom of the drive back plate. Push the top of the drive bracket toward the two latches. The drive bracket may have to be lifted slightly to let the threaded piston rod pass through the hole in the drive bracket. Maintain a slight engaging force on top of the drive bracket while deflecting the bracket slightly to the left by pressing on the side of the upper right corner. This helps the drive gears mesh with the drive cap assembly. The drive bracket is properly seated when it snaps under the latches on the drive back plate. If resistance is felt before latching, then notches are not fully engaged, the piston rod is not in hold, the wires are jammed between the drive bracket and drive back plate, or the gear is not engaging the drive cap assembly.

Drive Gear Replacement

To inspect the drive gears, the drive gear cover needs to be removed. Before trying to remove the gear cover, the drive bracket must be removed from the drive back plate. (Refer to the instructions above regarding removing the drive bracket from the drive back plate. The drive gear cover can be removed from the drive bracket without removing the motor or the PC board.) The drive gear cover is held in place on the drive bracket by three clips. The largest of the three clips is always orientated to the bottom of the drive bracket. With the

PC board facing up, push in and down on the large clip on the drive gear cover. Handle the cover and the gears carefully so that the gears do not fall off the pegs in the cover.

Replace broken or damaged drive gears. Do not lubricate any of the gears. Avoid getting any foreign matter on the reflective coating because dirt or oils may interfere with pulse counting.

The drive gear cover only fits on one way, with the large clip orientated towards the bottom. If all three clips are outside of the gear shroud on the drive bracket the drive gear cover slips easily into place.

Drive Motor Replacement

The drive bracket does not need to be removed from the drive plate if the motor needs to be removed. To remove the motor, disconnect the power and motor plugs from the jacks on the PC board. Move the spring clip loop to the right and hold. Rotate the motor at least a 1/4 turn in either direction so the wires are vertical (up & down) before gently pulling on the wire connectors to remove the motor. Pulling directly on the wires without rotating the motor may break the wires off the motor.

Replace the motor if necessary. Do not lubricate the motor or the gears. To reinstall the motor, move the spring clip loop to the right and hold. Gently turn the motor while inserting so that the gear on the motor meshes with the gears under the drive gear cover. Release the spring clip loop and continue to rotate the motor until the wires are horizontal and the motor housing engages the small plastic bulge inside the drive bracket motor retainer. Reconnect the motor plug to the two-pronged jack on the lower left side of the PC board. If the motor will not easily engage with the drive gears when reinstalling, lift and slightly rotate the motor before reinserting. Reconnect the power plug.

Replace the valve cover. After completing any valve maintenance, press and hold NEXT and REGEN buttons for 3 seconds or unplug power source jack (black wire) and plug back in. This resets the electronics and establishes the service piston position. The display should flash all wording, then flash the software version and then reset the valve to the service position.

Drive Cap Assembly, Main Piston and Regenerant Piston

The drive assembly must be removed to access the drive cap assembly. The drive cap assembly must be removed to access the piston(s). The drive cap assembly is threaded into the control valve body and seals with an o-ring. To remove the drive cap assembly use the special plastic wrench or insert a 1/4" to 1/2" flat blade screwdriver into one of the slots around the top 2" of the drive cap assembly so it engages the notches molded into the drive back plate around the top 2" of the piston cavity. See Figure 29. The notches are visible through the holes. Lever the screwdriver so the drive cap assembly turns counter clockwise. Once loosened, unscrew the drive cap assembly by hand and pull straight out.

The drive cap assembly contains the drive cap, the main drive gear, drive cap, piston rod and various other parts that should not be disassembled in the field. The only replaceable part on the drive cap assembly is the o-ring. Attached to the drive cap assembly is the main piston and if a regenerant is used, a regenerant piston.

The regenerant piston (the small diameter one behind the main piston) is removed from the main piston by pressing sideways and unsnapping it from its latch. Chemically clean this in dilute sodium bisulfite or vinegar, or replace the regenerant piston if needed. To remove the main downflow or upflow piston fully extend the piston rod and then unsnap the main piston, from its latch by pressing on the side with the number. Chemically clean this in dilute sodium bisulfite or vinegar, or replace the main piston.

Reattach the main piston to the drive cap assembly. Reattach the regenerant piston (if needed) to the main piston. Do not lubricate the piston rod, main piston or regenerant piston. Lubricant will adversely affect the clear lip seals. Reinsert the drive cap assembly and piston into the spacer stack assembly and hand tighten the drive cap assembly. Continue to tighten the drive cap assembly using a screwdriver as a ratchet until the black o-ring on the spacer stack assembly is no longer visible through the drain port. Excessive force can break the notches molded into the drive back plate. Make certain that the main drive gear still turns freely. The exact position of the piston is not important as long as the main drive gear turns freely.

Reattach the drive assembly to the control valve and connect all plugs. After completing any valve maintenance, press and hold NEXT and REGEN buttons for 3 seconds or unplug power source jack (black wire) and plug back in. This resets the electronics and establishes the service piston position. This display should flash all wording, then flash the software version and then reset the valve to the service position.

Spacer Stack Assembly

To access the spacer stack assembly remove the drive assembly, drive cap assembly and piston. The spacer stack assembly can be removed easily without tools by using thumb and forefinger. Inspect the black o-rings and clear lip seals for wear or damage. Replace the entire stack if necessary. Do not disassemble the stack.

The spacer stack assembly may be chemically cleaned (dilute sodium bisulfite or vinegar) or wiped with a soft cloth.

The spacer stack assembly can be pushed in to the control valve body bore by hand. Since the spacer stack assembly can be compressed it is easier to use a blunt object (5/8" to 1-1/8" in diameter) to push the center of the assembly into the control valve body. The assembly is properly seated when at least four threads are exposed (approximately 5/8"). Do not force the spacer stack assembly in. The control valve body bore interior can be lubricated with silicone to allow for easy insertion of the entire stack. Do not use silicone or any other type of lubricant on the clear lip seals or the piston.

Reattach the drive cap assembly and the piston(s) and the drive assembly.

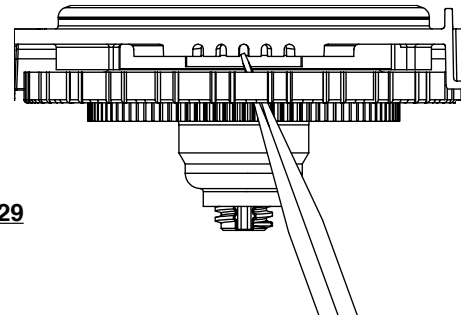

Figure 29

After completing any valve maintenance, press and hold NEXT and REGEN buttons for 3 seconds or unplug power source jack (black wire) and plug back in. This resets the electronics and establishes the service piston position. The display should flash all wording, then flash the software version and then reset the valve to the service position.

Injector Cap, Screen, Injector Plug and Injector Replacement

Unscrew the injector cap and lift off. Loosen cap with special plastic wrench or pliers if necessary. Attached to the injector cap is a screen. Remove the screen and clean if fouled.

Reattach the drive cap assembly and the piston(s) and the drive assembly.

After completing any valve maintenance, press and hold NEXT and REGEN buttons for 3 seconds or unplug power source jack (black wire) and plug back in. This resets the electronics and establishes the service piston position. The display should flash all wording, then flash the software version and then reset the valve to the service position.

Injector Cap, Screen, Injector Plug and Injector Replacement

Unscrew the injector cap and lift off. Loosen cap with special plastic wrench or pliers if necessary. Attached to the injector cap is a screen. Remove the screen and clean if fouled.

The plug and/or injector can be pried out with a small screwdriver. The plug can be wiped clean. If the plug leaks replace the entire plug. The injector consists of a throat and a nozzle. Chemically clean the injector with vinegar or sodium bisulfite. The holes can be blown out with air. Both pieces have smaller diameter holes that control the flow rates of water to insure that the proper concentration of regenerant is used. Sharp objects, which can score the plastic, should not be used to clean the injector. Scoring the injector or increasing the diameter of the hole could change the operating parameters of the injector.

Two holes are labeled DN and UP. Check for compliance. See Table Below.

COMPLIANCE TABLE

Application	Injector and/or Plug(s)	Main Piston	Regenerant Piston	Stack
H125 Downflow Softener or Regenerating Filter (1.32" Distributor)	Injector in "DN" hole, Plug in "UP" Hole	102291	102296	102547
H125 Backwash Only Filter (1.32" Distributor)	Plug in "DN" and "UP" holes, Install Refill Port Plug	102291	None	102547

Push the plug(s) and/or injectors firmly in place, replace the screen and hand tighten the injector cap.

Refill Flow Control Assembly or Refill Port Plug

To clean or replace the refill flow control, pull out the elbow-locking clip and then pull straight up on the elbow. Replace the elbow locking clip in the slot so that it is not misplaced. Twist to remove the white flow control retainer. The flow control can be removed by prying upward through the side slots of the retainer with a small flat blade screwdriver.

Chemically clean the flow control or the white flow control retainer using dilute sodium bisulfite or vinegar. Do not use a wire brush. If necessary, replace the flow control, o-ring on the flow control retainer, or the o-ring on the elbow.

Reseat the flow control so the rounded end is visible in the flow control. Reseat the white flow control retainer by pushing the retainer into the elbow until the o-ring seats. Remove locking clip, push down on elbow to reseat and insert locking clip.

Do not use Vaseline, oils, or other unacceptable lubricants on o-rings. A silicone lubricant may be used on the o-ring on the elbow or the white retainer.

Water Meter or Meter Plug

The water meter assembly is connected to the PC board by a wire. If the entire water meter assembly is to be replaced, remove the control valve cover and disconnect the power source and water meter plugs from the PC board. Unlatch the drive assembly and lean it in forward. Unthread the water meter wire from the side of the drive assembly and through the drive back plate. To reinstall, rethread the water meter through the drive back plate and side of the drive assembly. Reattach the drive assembly and the water meter and power plugs.

If no water meter is visible, then a plug is installed, not a water meter.

The water meter wire does not need to be removed from the PC board if the water meter is only being inspected and cleaned. To remove the water meter assembly, unscrew the meter cap on the left side of the control valve. Pliers may be used to unscrew the nut if necessary.

With the nut removed, a slot at the top of the water meter is visible. Twist a flat blade screwdriver in the slot between the control valve body and the meter. When the meter is part way out it is easy to remove the water meter from the housing. Once the water meter is removed from the control valve body, gently pull forward on the turbine to remove it from the shaft.

Do not use a wire brush to clean the turbine. Wipe with a clean cloth or chemically clean in dilute sodium bisulfite or vinegar. The turbine can be immersed in the chemical.

Do not immerse electronics. If the turbine is scored or damaged or the bearings on the turbine are worn, replace the turbine.

Do not lubricate the turbine shaft. The turbine shaft bearings are prelubricated. Do not use Vaseline, oils, or other unacceptable lubricants on the o-ring. A silicone lubricant may be used on the black o-ring.

Snap the turbine on the shaft and reinsert the water meter into the side slot. Hand tighten the nut. Do not use a pipe wrench to tighten nut.

Bypass Valve

The working parts of the bypass valve are the rotor assemblies that are contained under the bypass valve caps. Before working on the rotors, make sure the system is depressurized. Turn the red arrow shaped handles towards the center of the bypass valve and back several times to ensure rotor is turning freely.

The nuts and caps are designed to be unscrewed or tightened by hand. If necessary a pliers can be used to unscrew the nut or cap. Do not use a pipe wrench to tighten or loosen nuts or caps. Do not place screwdriver in slots on caps and/or tap with a hammer. To access the rotor, unscrew the cap and lift the cap, rotor and handle out as one unit. Twisting the unit as you pull it out will help to remove it more easily. There are three o-rings: one under the rotor cap, one on the rotor stem and the rotor seal. Replace worn o-rings. Clean rotor. Reinstall rotor.

When installing the red arrow handles be sure that:

1. The handle pointers are lined up with the control valve body arrows, and the rotor seal o-ring and retainer on both rotors face to the right when being viewed from the front of the control valve; or
2. Arrows point toward each other in the bypass position.

Since the handles can be pulled off, they could be accidentally reinstalled 180° from their correct orientation. To install the red arrow handles correctly, keep the handles pointed in the same direction as the arrows engraved on the control valve body while tightening the bypass valve caps.

After completing any valve maintenance, press and hold NEXT and REGEN buttons for 3 seconds or unplug power source jack (black wire) and plug back in. This resets the electronics and establishes the service piston position. The display should flash all wording, then flash the software version and reset the valve to the service position.

SERVICE RATES & PRESSURE DROP CHARTS

H125-32-10

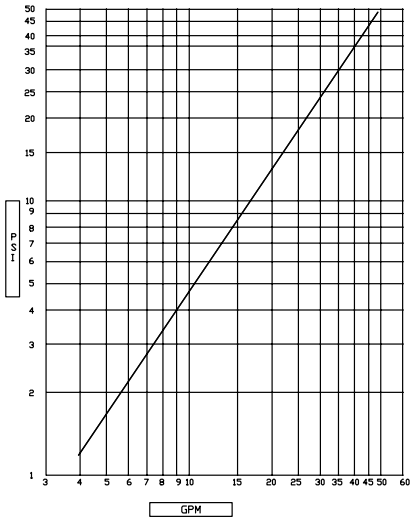

H125-48

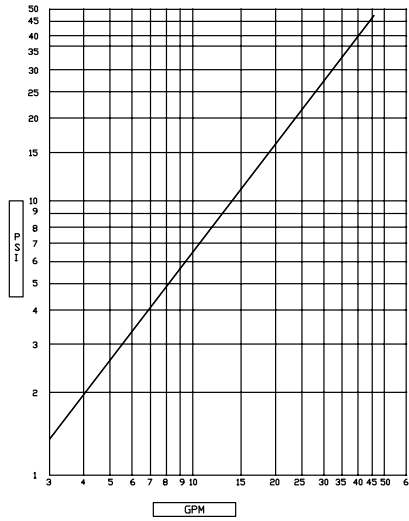

H125-64

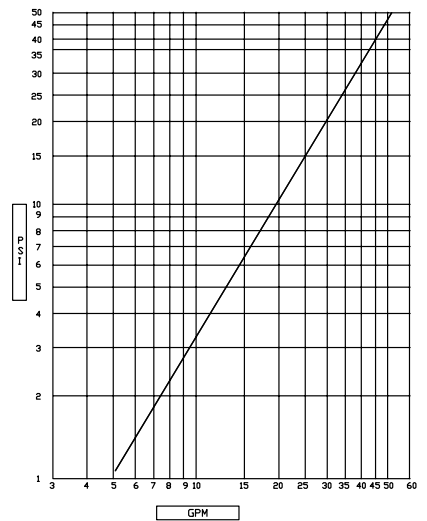

H125-96

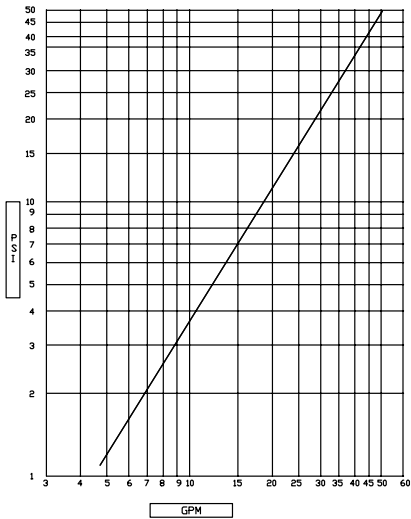

H125-128

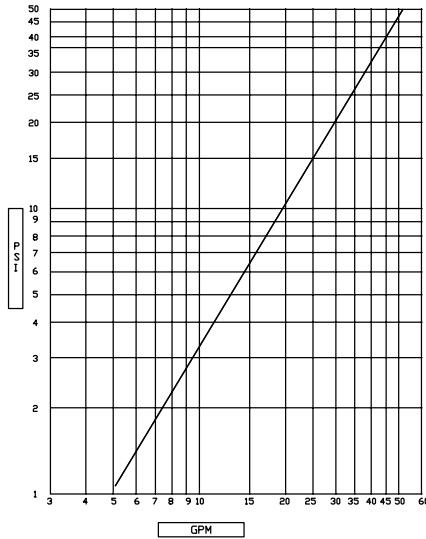

H125-160

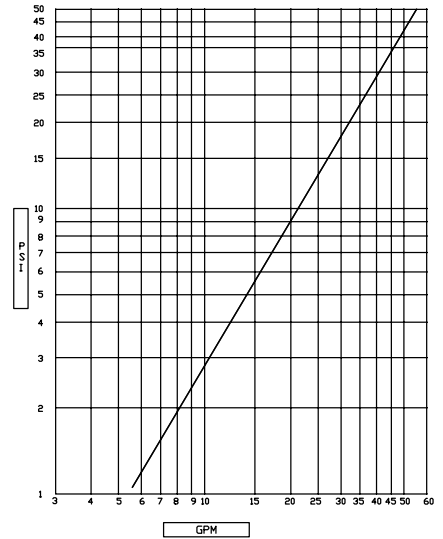

H125-192

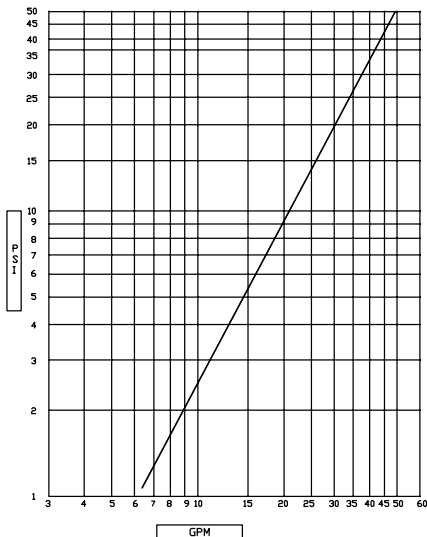

H125 SPECIFICATIONS

Model #	H125	H125	H125	H125	H125	H125	H125
	32-10	48	64	96	128	160	192
Factory Regeneration Settings							
Fill Minutes	6.7	10.0	13.4	20.0	26.7	33.4	40.0
Fill Gallons	3.4	5.0	6.7	10.0	13.4	16.7	20.0
Brine/Rinse Minutes	60	60	68	68	68	68	68
Brine/Rinse Gallons	19.2	22.2	43.5	47.7	71.1	89.1	113
Backwash Minutes	8	8	8	8	8	8	8
Backwash Gallons	17.6	17.6	33.6	33.6	8.8	11.2	14.4
Fast Rinse Minutes	4	4	4	4	4	4	4
Fast Rinse Gallons	8.8	8.8	16.8	16.8	21.2	30.0	30.0
Total Regeneration Gallons*	48.9	53.6	100.6	108.1	148.1	195.8	223.0

* Calculations are based on factory medium salt setting @ 50 psi

Refill LBS of salt	Lbs.	Lbs.	Lbs.	Lbs.	Lbs.	Lbs.	Lbs.
Efficient Salt	5	7.5	10	15	20	25	30
Low Salt	6	9	12	18	24	30	36
Medium Salt	10	15	20	30	40	50	60
High Salt	15	22.5	30	45	60	75	90

Capacity - Efficiency	Grains	Grains	Grains	Grains	Grains	Grains	Grains
Efficient - 4000 grains/lb.	20,000	30,000	40,000	60,000	80,000	100,000	120,000
Low Salt - 3821 grains/lb	22,930	34,400	45,852	68,778	91,704	114,630	137,556
Medium Salt - 2800 grains/lb	28,000	42,000	56,000	84,000	112,000	140,000	168,000
High Salt - 2133 grains/lb	31,995	47,993	63,990	95,985	127,980	159,975	191,970

Service Flow Rates	GPM	GPM	GPM	GPM	GPM	GPM	GPM
Continuous @ 15 psi	22	19	25	24	25	27	26
Peak @ 25 psi	31	28	34	33	34	35	34

Flint Under bed (lbs.)	14	14	40	40	45	50	75
High Capacity Resin (cu.ft.)	1	1.5	2	3	4	5	6
Resin Tank Size	10x44	10x54	13x54	14x65	16x65	18x65	18x65
Recommended Brine Tank	18x40	18x40	18x40	18x40	24x41	24x50	24x50
Min/Max Salt Setting in Lbs.	7/28	7/28	7/28	17/36	23/76	23/76	23/76
Optional Grid Height**	5"	5"	5"	8"	6"	6"	6"
Brine Line Size	3/8"	3/8"	3/8"	3/8"	3/8"	1/2"	1/2"
DLFC (gpm)	2.2	2.2	4.2	4.2	5.3	7.5	7.5
BLFC (gpm)	0.5	0.5	0.5	0.5	0.5	0.5	0.5
Injector Size	D-Red	E-White	G-Yellow	H-Green	I-Orange	J- Lt. Blue	K- Lt. Green
Injector Draw Rate @ 50 psi	0.22	0.27	0.46	0.46	0.6	0.7	0.7
Injector Slow Rinse @ 50 psi	0.32	0.37	0.64	0.71	1.1	1.4	1.8

***Factory Settings are in bold.** Factory settings are programmed for clean, iron-free water, such as city water supplies, for efficient water use. On water supplies with turbidity and/or iron concentrations >0.5 ppm, recommend programming second backwash cycle after brine cycle to maintain resin for optimal performance (see page 18 for programming instructions).

System conforms to ANSI/NSF 44 for specific performance claims as verified and substantiated by test data. Efficiency is measured by a laboratory test as described in NSF/ANSI 44, testing represents maximum efficiency system can achieve. Operational efficiency is achieved after system is installed and may be less than tested efficiency due to application parameters such as water hardness, TDS and other contaminants that reduce the softeners capacity.

COMMERCIAL WATER SOFTENER & FILTER LIMITED WARRANTY

INCLUDES – H125, H151, H200M, H200, H300, NF, TS, TN2 & TNT SYSTEMS

(Warranty Updated 10/14)

Hellenbrand, Inc., (“Hellenbrand”) warrants to the original purchaser that the system and the parts listed below will be free from defects in material and/or workmanship from the date of the original installation for the following time periods:

For a Period of FIVE YEARS: The filter control valve electrical parts including the motor and board, control valve body, and internal parts.

For a Period of FIVE YEARS: SystemMate Controller.

For a Period of TEN YEARS: Mineral tanks, 6” Diameter - 13” Diameter.

For a Period of FIVE YEARS: Mineral tanks, 14” Diameter - Up.

For a Period of FIVE YEARS: The salt storage/cabinet tank.

For a Period of ONE YEAR: The entire water conditioner system (“System”).

Any parts used for replacement are warranted for the remainder of the original warranty period for the applicable part.

THIS WARRANTY IS EFFECTIVE TO THE ORIGINAL PURCHASER ONLY, AND ONLY FOR AS LONG AS THE SYSTEM REMAINS AT THE ORIGINAL INSTALLATION SITE. COVERAGE TERMINATES IF YOU SELL OR OTHERWISE TRANSFER THE SYSTEM OR IF THE SYSTEM IS MOVED FROM THE ORIGINAL INSTALLATION SITE.

No sales representative, distributor, agent, dealer, reseller, authorized seller or any other person or entity is authorized to make any other warranty, or modify or expand the warranty provided herein on behalf of Hellenbrand. Upon expiration of the applicable warranty period, Hellenbrand shall have no further liability related to the System/parts to which the warranty period applies, except with respect to valid warranty claims asserted during the appropriate warranty period.

If the System or any part described above becomes defective within the specified warranty period, you should notify your local authorized seller of Hellenbrand products, and arrange a time during normal business hours for the inspection of the System at the original installation site. You may also contact Hellenbrand and we will provide you with the contact information for your local authorized seller of Hellenbrand products. Hellenbrand, at its option, will repair or replace the System or any part found defective within the terms of this warranty. You are responsible for freight from our factory and any service fees charged by the local authorized seller of Hellenbrand products for installation, repair, removal, replacement, service, etc., of any System or parts. This warranty does not include any labor charges. This paragraph sets forth the exclusive remedy for any valid warranty claims against Hellenbrand.

THIS WARRANTY DOES NOT COVER defects caused by sand, sediment or bacteria fouling, accident, fire, flood, Act of God, misuse, misapplication, neglect, alteration, installation or operation contrary to Hellenbrand’s printed instructions, or installation, repair or service by anyone other than Hellenbrand or an authorized seller of Hellenbrand products.

IN ADDITION, THIS WARRANTY DOES NOT COVER UNPROTECTED OUTDOOR INSTALLATIONS. This System, including all of the electrical components, must be protected against windblown dust, falling and windblown rain, freezing temperatures and the formation of ice, with an appropriate enclosure consisting of a floor, roof, walls, ventilation and heat.

As a manufacturer, we do not know the characteristics of your water supply or the purpose for which you are purchasing this system. You should be aware that the quality of water supplies may vary seasonally or over a period of time, and that your water usage rate may vary as well. Water characteristics may change considerably if this System is moved to a new location. For these reasons, Hellenbrand assumes no liability for the determination of the proper equipment necessary to meet your needs; and Hellenbrand does not authorize others to assume such obligations for Hellenbrand.

TO THE EXTENT PERMITTED BY APPLICABLE LAW, REMEDIES FOR DEFECTS OR FAILURES ARE LIMITED TO THE REMEDIES PROVIDED IN THIS WARRANTY. THERE ARE NO EXPRESS WARRANTIES OTHER THAN THOSE SET FORTH HEREIN. TO THE EXTENT PERMITTED BY APPLICABLE LAW, HELLENBRAND HEREBY DISCLAIMS ALL OTHER WARRANTIES, WHETHER STATUTORY, EXPRESS OR IMPLIED INCLUDING, WITHOUT LIMITATION, IMPLIED WARRANTIES OF MERCHANTABILITY, FITNESS FOR PARTICULAR PURPOSE, NON-INFRINGEMENT, OR ANY WARRANTIES ARISING FROM COURSE OF PERFORMANCE, COURSE OF DEALING, OR FROM USAGES OF TRADE.

UNDER NO CIRCUMSTANCES SHALL HELLENBRAND BE LIABLE TO THE ORIGINAL PURCHASER OR TO ANY OTHER PERSON FOR ANY INCIDENTAL, INDIRECT, SPECIAL OR CONSEQUENTIAL DAMAGES OR FOR ANY OTHER LOSS, DAMAGE, OR EXPENSE OF ANY KIND, INCLUDING LOSS OF PROFITS, WHETHER ARISING OUT OF BREACH OF WARRANTY, BREACH OF CONTRACT, IN TORT OR OTHERWISE, AND REGARDLESS OF WHETHER HELLENBRAND WAS AWARE OF THE POSSIBILITY OF SUCH LOSS. THESE LIMITATIONS WILL APPLY REGARDLESS OF ANY FAILURE OF ESSENTIAL PURPOSE OF ANY LIMITED REMEDY.

Some states do not allow limitations on how long an implied warranty lasts, so the above limitations may not apply to you. Similarly, some states do not allow the exclusion or limitation of incidental or consequential damages, so the above limitation or exclusion may not apply to you. This warranty gives you specific legal rights, and you may also have other rights which vary from state to state.