

Hellenbrand

HELLENBRAND
H-100 SERIES



12 Volt Electronics

Owner's Manual

©2001-2007

Manufactured by:
HELLENBRAND, INC.
404 Moravian Valley Road
Waunakee, Wisconsin 53597
Phone: 608-849-3050 • Fax 608-849-7398
Web: www.hellenbrand.com • Email: info@hellenbrand.com

This owner's manual is designed to assist owners and installers with the operation, maintenance and installation of your new water softener. It is our sincere hope that this manual is clear, concise and helpful to both owner and installer. We have included detailed instructions on general operating conditions, pre-installation and installation instructions, start-up, and timer and meter programming. We have included a troubleshooting guide, service instructions and parts diagrams to assist you.

Owners will appreciate the simplified, illustrated format for operation, programming and troubleshooting. **In the event that you need professional assistance for servicing your water softener, please contact the dealer who installed this system.**

TABLE OF CONTENTS

Job Specification Sheet	Page 2
Operating Conditions	2
Soft Water Basics	3
Frequently Asked Questions	3
Pre-Installation Check List	4
Installation Instructions	5
Programming	6
Displays/Settings	7
Water Softener Disinfection	9
Water Softener Draining Procedure	9
Trouble Shooting	10-11
Parts Diagrams	12-17
Specifications	18-20
Warranty	20

JOB SPECIFICATION SHEET

MODEL NO. _____

*WATER TEST AT TIME OF INSTALLATION

_____ Hardness CaCo ₃ (gpg)	_____ Other _____
_____ Iron (ppm)	_____ Other _____
_____ pH	_____ Other _____

*SIZING INFORMATION

All Water is Softened Except:

_____ Rear Hose Bib _____ Front Hose Bib _____ Kitchen Cold _____ Toilets _____ All Cold
 _____ Other _____

The average family uses 75 gallons per person daily for all water uses in the home, about 50 gallons per person daily if soft water is not supplied to the toilets, and about 30 gallons per person daily if only hot water is softened.

_____ Daily Water Usage (Gallons/Person)
 x _____ Family Size (Number of people in family)
 = _____ Total Gallons Per Day
 x _____ Grains Per Gallon of Total Compensated Hardness
 (Note: Add 3 grains per gallon of hardness for each ppm iron for total compensated hardness)
 = _____ Total Grains Per Day

*INSTALLATION DATE _____

*SERIAL NUMBER _____

NOTES _____

OPERATING CONDITIONS

Your water conditioner has been designed to adequately handle up to 100 grains per gallon of hardness as well as up to 2 ppm of Ferrous Bicarbonate Iron. This is iron that is dissolved in an oxygen-free water supply. It is not visible to the eye in a freshly drawn sample because the water appears clear. But upon standing in contact with air, the ferrous iron will become oxidized to the ferric state and start to precipitate as a reddish brown floc. It can then be seen and if allowed to remain in the supply will cause discolored water. In order for your conditioner to remove the iron, air (oxygen) must be kept from coming in contact with

water until after it has been passed through the water conditioner. In some cases, additional equipment may be required to treat water supplies having special characteristics, such as: oxidized iron, iron bacteria, low pH, taste and odors, etc. If any question should exist, contact your dealer.

This conditioner is not intended to be used for treating water that is microbiologically unsafe or of unknown quality without adequate disinfection before or after the system.

SOFT WATER BASICS

Hardness

Excess amounts of calcium and magnesium in water produce hardness. A water softener removes the majority of calcium and magnesium to produce softened water.

Hardness is measured in terms of grains. (This grain weight is derived from the average weight of a dry grain of wheat.) When your water is tested the grain hardness is calculated and expressed as grains per gallon (gpg). This calculation, as well as the number of people in your household will help determine what type and size of water softener will most efficiently soften your water.

Your water softener contains an ion exchange media (sometimes called resin) which removes the hardness from water as it flows through the softener tank. Eventually so much hardness collects on the exchange media that the softener can no longer soften water. At this point it is considered "exhausted". Regeneration is now necessary.

Regeneration

To regenerate the exchange media, it must be rinsed with a brine (salt) solution. This removes the hardness from the exchange media and replaces it with sodium. The exchange media is then ready to remove hardness from water. The hardness minerals and excess brine solution are rinsed down the drain.

During the regeneration cycle the softener is also backwashed. This reversing of the normal flow of water serves to remove sediment which may have accumulated during the softening process due to the filtering action of the exchange media. Backwashing also loosens and fluffs up the bed of exchange media to insure that during regeneration the brine solution will come into contact with all the media.

Maintenance of Your Softener

Salt: Salt to a softener is what gasoline is to a car. Not only must a softener have salt, but it should be the proper type to insure efficient recharging of the unit. Ask your dealer what type of salt may best suit your needs. Always have an adequate supply of salt on hand. Check the salt level of your salt keeper periodically. Fill the tank approximately three-fourths full, with a minimum of 12" of salt.

Cleaning Salt Keeper: Salt keeper may require periodic cleaning. Inspect the salt keeper at least once a year for buildup of insoluble materials. It is recommended to periodically clean the salt keeper no matter what kind of salt you are using. See page 9, miscellaneous #2 for details on cleaning.

REMEMBER: Salt is the fuel to run your water softener. Buy the **best clean salt available**.

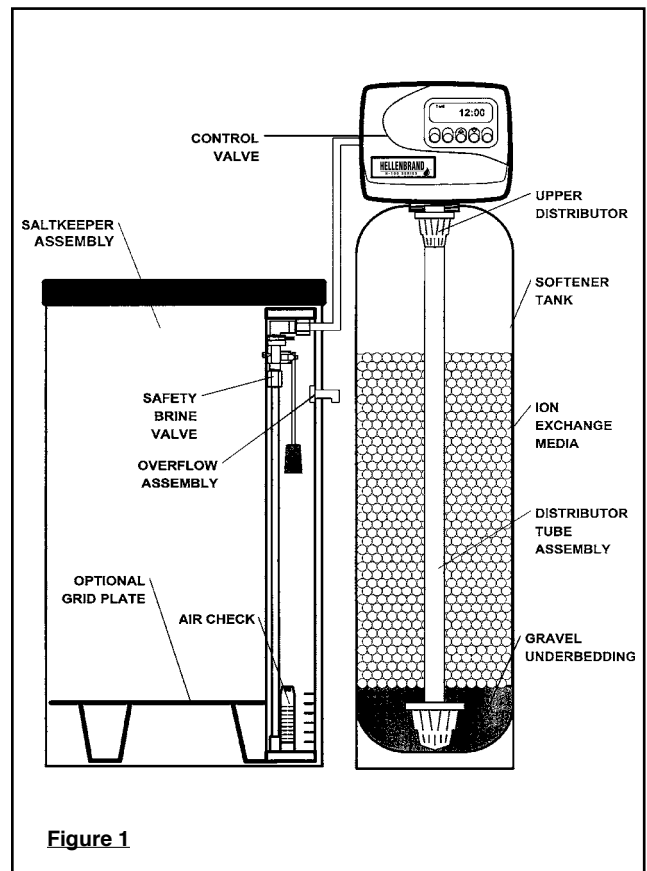

Figure 1

FREQUENTLY ASKED QUESTIONS

- 1. Do I still use the same amount of soap in the dishwasher and clothes washer and showers now that I have a water softener?**
No, the Water Quality Association states soft water can save up to 55% on detergent use. Start with using half the amount of detergent previously used, this can be adjusted up or down based on preference. Soft water helps fabrics last longer, because hardness minerals combined with soap can make fabric fibers brittle.
- 2. What is the health impact of drinking soft water?** The sodium added to water by a softening is a non-issue most of the time, even for people on a sodium-restricted diet. One could soften up to 75 grains per gallon water with sodium chloride and still be well within the US Food and Drug Administration's guidelines for a "Low Sodium" beverage. People on a sodium-restricted diet should consult their physician.
- 3. Should I use soft water for my plants?** Some plants may be sensitive to even minute amounts of sodium. Suggest using hard water for watering plants, often a kitchen cold faucet is plumbed for hard water or the outside faucets are usually plumbed for hard water. If not, you can place your softener on bypass and fill water containers at the closest sink. Water from a reverse osmosis system can always be used to water plants.
- 4. Will water spots disappear now that I have soft water?** Water spots caused by hardness scale will disappear with a functioning water softener. However, other natural minerals dissolved in the water may cause spotting in high enough concentrations. These mineral spots will be much easier to wipe away compared to hardness spotting.
- 5. Will soft water cause my water or ice cubes to look or taste different?** Most people can tell the difference in taste between hard and soft water, it is a personal preference. Ice cubes will appear the same, they may look cloudy due to air in water or dissolved minerals, and this will not change because they are made with softened water. A reverse osmosis drinking water system will provide clearer ice cubes.

PRE-INSTALLATION CHECK LIST

(All electrical & plumbing should be done in accordance to all local codes)

Water Pressure: A minimum of 25 pounds of water pressure (psi) is required for regeneration. Maximum 120 psi.

Water Quality: On rural water supplies there is often a problem with sand or sediment in the water. (This problem occasionally occurs in public water supplies.) If the water is not filtered before being softened, the sand and sediment will plug up the water softener restricting the flow through the resin bed. This problem often requires rebedding of the mineral tank. **Note:** Well and/or pump problems affecting the operation of the softener are repairs that are not covered under warranty. To prevent these unnecessary, and expensive repairs that are not covered under warranty, Hellenbrand recommends installing an in-line filter system ahead of softeners.

Electrical: A continuous 110 volt 60 cycle current supply is required. Make certain the current supply is uninterrupted and cannot be turned off with another switch. All electrical connections must be connected per local codes. **Surge protection is recommended with all electronic controls.**

Existing Plumbing: Condition of existing plumbing must be free from lime and iron build-up. Piping that is built-up heavily

with lime and/or iron must be replaced. If piping is blocked with iron, additional equipment must be installed ahead of the water conditioner to correct the problem.

Drain Line: The conditioner should be located close to a drain. Avoid overhead drain lines if possible to prevent back pressure on the brine injector. Overhead drains are not to exceed 8 feet above the floor and no more than 20 feet in length. The pipe size for the drain line should be a minimum of 3/4". Backwash flow rates in excess of 10 gpm or length in excess of 20' require 1" drain line. Verify connection to sanitary waste system is through proper air gap.

Bypass Valves: Always provide for the installation of a bypass valve.

Softening: It is recommended that the conditioner be installed to soften both the hot and cold water supply. A separate hard water faucet may be plumbed for drinking purposes if you desire. Outside faucets should be left on hard water.

Caution: Water temperature is not to exceed 110°F; the conditioner cannot be subject to freezing conditions, or to a vacuum due to loss of pressure (such as a water main break).

BYPASS VALVE OPERATION

NORMAL OPERATION Softening - Filtering

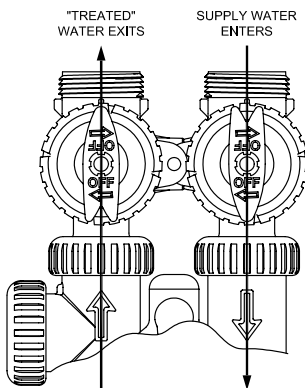

Figure 2

BYPASS OPERATION

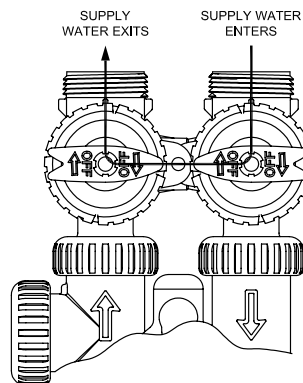

Figure 3

DIAGNOSTIC MODE

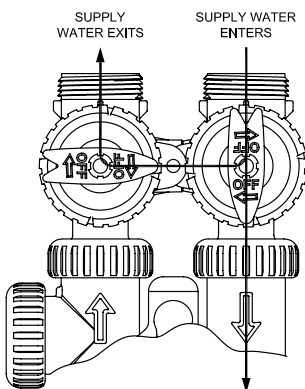

Figure 4

SHUT OFF MODE

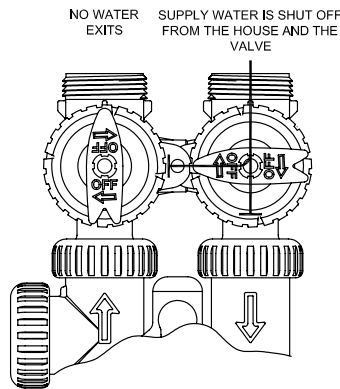

Figure 5

INSTALLATION INSTRUCTIONS

(All electrical & plumbing should be done in accordance to all local codes)

- Do not use vaseline, oils, other hydrocarbon lubricants or spray silicone anywhere. A silicon lubricant may be used on black o-rings but is not necessary. **Avoid any type of lubricants, including silicone, on red or clear lip seals.**
 - Do not use pipe dope or other sealants on threads. Only teflon tape may be used on threads. Teflon tape is not necessary on the nut connection or caps because of radial o-ring seals.
 - The pipe size for the drain line should be a minimum of 3/4". Backwash flow rates in excess of 10 gpm or length in excess of 20' require 1" drain line.
- Place the conditioner where you want to install it, making sure it is on a clean, level and firm base.
 - Do all necessary plumbing (inlet to inlet, outlet to outlet and drain line to drain). The control valve, fittings and/or bypass are designed to accommodate minor plumbing misalignments but are not designed to support the weight of a system or the plumbing.
 - When assembling the installation fitting package (inlet and outlet), connect the fitting to the plumbing system first and then attach the nut, split ring and o-ring. Heat from soldering or solvent cements may damage the nut, split ring or o-ring. Solder joints should be cool and solvent cements should be set before installing the nut, split ring and o-ring. Avoid getting primer and solvent cement on any part of the o-rings, split rings, bypass valve or control valve.
 - A jumper ground wire should be installed between the inlet and outlet pipe whenever the metallic continuity of a water distribution piping system is interrupted. Install grounding strap on metal pipes.**
 - The drain connection may be made using either 5/8" polytube (See figure 6a, page 5) or a 3/4" female adapter. If soldering, joints near the drain must be done prior to connecting the

drain line flow control fitting. Leave at least 6" between the drain line control fitting and solder joints when soldering pipes that are connected on the drain line control fitting. Failure to do this could cause interior damage to the drain line flow control fitting.

- The brine refill flow control assembly is installed in an easy to access refill elbow located on top of the control valve. The refill flow control assembly is attached to the control valve with a locking clip. The locking clip allows the elbow to rotate 270 degrees so the outlet can be orientated towards the salt keeper.
- Connect the brine line found in the salt keeper to the brine connection on the control valve. The control valve has a standard refill elbow to which a 3/8" flexible tube can be connected, see figure 6a, page 5. (An optional elbow can be ordered which accommodates a 1/2" flexible tube for a high regenerant draw rate situation). Both elbows use the same refill flow control and retainer. Do not connect the other end of the brine line to the safety brine valve in the salt keeper at this time. Make sure the floor is clean beneath the salt tank and that it is level and smooth. No grid is required with standard brine tank as softener is programming as prefill.
- A 1/2" (inside diameter) gravity drain line should be connected to the overflow elbow on the side of the brine tank and run to a drain below the level of the elbow. This overflow drainage system provides protection from water damage in the event of a brine shut-off malfunction. Tubing is not provided to do this.

In all cases where an overflow could result in water damage for various reasons, this overflow protection must be used. Do not connect the tubing to the drain line on the control valve discharge line and do not run this line above the overflow elbow height at any point. Provide air gap.

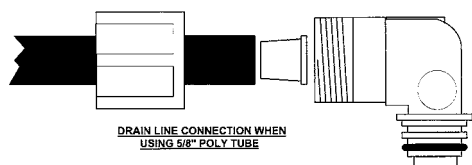
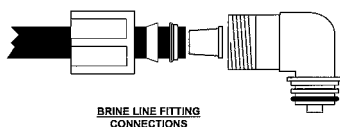

Figure 6a

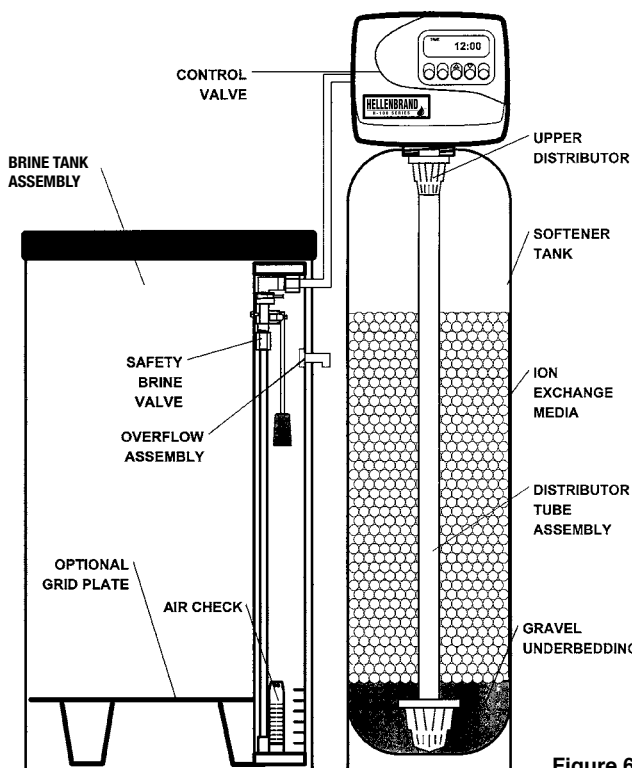

Figure 6b

PROGRAMMING

General Information

The Hellenbrand Series 100 control valve is the “brain” of your water softener. It consists of the valve body and powerhead with solid state microprocessor.

The display panel (see Figure 7) consists of the LED display, power light, and five push buttons which are used in displaying and programming the water softener settings.

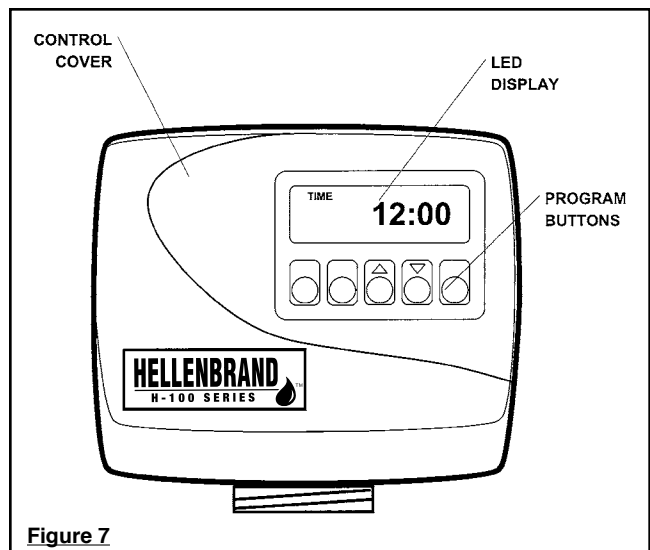

Initial Start Up

The initial start up will probably be done by the technician installing the softener system. If not, the following instructions will step you through the process.

1. Complete all plumbing connections: inlet, outlet, drain line and brine line. Do not add salt at this time.
2. Place the bypass valve in the bypass position. (See figure 3 page 4) Turn on the main water supply. Open a cold soft water faucet to flush the piping of any air and/or foreign material. Run until the water is clear.
3. Manually add 6 inches of water to the salt keeper.
4. Now plug the transformer into a 110-volt receptacle. (Be certain the outlet is uninterrupted.) Within 5 seconds the control will automatically align itself into the softening mode and the display will flash 12:00 (AM). (Figure 7, page 6).
5. Set the time of day (figure 8, page 7).
6. Push REGEN button and hold it down for 3 seconds. The system will advance to the “Fill” position. (Note: If the system is not programmed as “brine refill first”, “Backwash” will display first). Keep pushing REGEN button until “Rinse” shows in the lower right hand corner of display. Slowly place the by-pass into the “diagnostic mode” (see fig 4, page 4). Run water to the drain until it runs clear. Return the by-pass valve to the by-pass position (fig 3, page 4). Push REGEN button one more time, “Time” will appear in upper left hand corner of display.
7. Once again, push REGEN button and hold down for 3 seconds. Keep pushing REGEN button until “Backwash” appears. Slowly place the by-pass valve into the “Diagnostic Mode” 1/2 way. Allow water to slowly fill the mineral tank. When a solid stream of water starts coming out of the drain line, open the by-pass inlet valve all the way and allow to run out the drain until water clears. Then slowly place the by-pass into the “normal operation” mode by opening the outlet side of by-pass valve, figure 2, page 4.
8. Press the regen button one more time. LED display should say “BRINE”. Loosen the brine line from the top of the safety brine valve in the brine tank. Place finger over the end of the tube to check for suction. If no suction, see trouble-shooting guide. (See #11, Page 11) If proper suction, reattach brine tube to safety brine valve, and allow it to draw water down to the bottom of the air check, (figure 6b, page 5).
9. Press REGEN button once again. LED will once again display “BACKWASH”. Keep in backwash until water once again runs clear at the drain.
10. Press REGEN button again. LED will display “RINSE”. Allow rinse cycle to run its full circle. While the rinse cycle is finishing, this would be a good time to load your brine tank with salt. The brine tank does not require a grid because softener is programmed to fill brine tank with appropriate volume of water 2 hours prior to regeneration.
11. Once the rinse cycle has finished the softener control will return to the softening cycle. The LED screen will indicate “TIME”.
12. Next set your softeners water hardness, days override and regeneration time settings (see figure 9, page 7).

Your programming is now complete.

SET TIME OF DAY

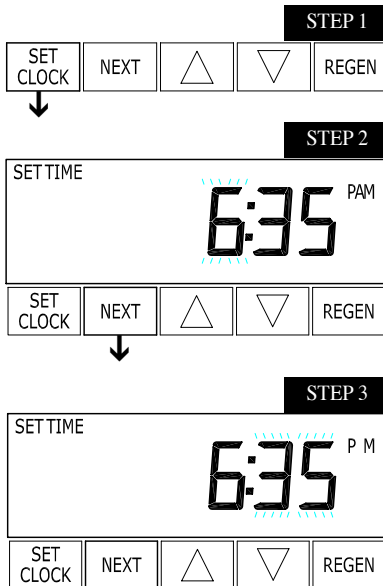

Figure 8

Step 1 - Press SET CLOCK.

Step 2 - Current Time (hour): Set the hour of the day using ▲ or ▼ buttons. AM/PM toggles after 12. Press NEXT to go to step 3.

Step 3 - Current Time (minutes): Set the minutes of day using ▲ or ▼ buttons. Press NEXT to exit Set Clock. Press REGEN to return to previous step.

Power Loss - Lithium battery on circuit board provides up to 8 hours of time clock backup during power outages. After 8 hours, only the time of day needs to be reset, all other values are stored in non-volatile memory. If a power loss last less than 8 hours and time of day is flashing, replace coin type 2032 battery. Do not forget to reset for daylight savings time.

INSTALLER DISPLAYS/SETTINGS

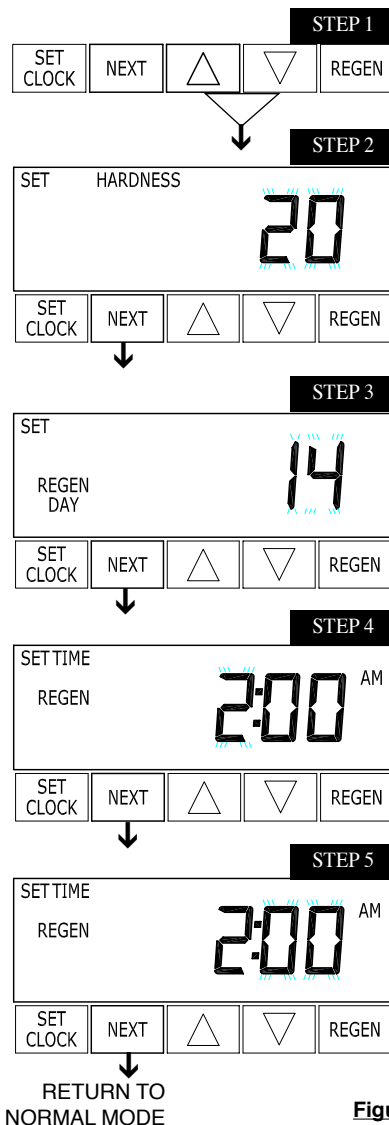

Figure 9

Step 1 - Press NEXT and ▲ simultaneously for 3 seconds.

Step 2 - Hardness: Set the amount of total compensated hardness in grains (hardness as calcium carbonate) per gallon using ▲ or ▼ buttons. The default is 20 with value ranges from 1 to 150 in 1 grain increments. Note: The grains per gallon should be increased if soluble iron needs to be reduced. Add 3 grains of hardness for each ppm of iron present. If this display shows nA -, then system is either set-up in "time clock" or "filter" modes. (See table 6, page 19). Press NEXT to go to Step 3. Press REGEN to exit Installer Displays/Settings.

Step 3 - Day Override: This sets the number of days between regenerations. If value is set to "oFF" regeneration initiation is based solely on gallons used. If value is set as a number (allowable range from 1 to 28) a regeneration initiation will be called for on that day even if sufficient number of gallons were not used to call for a regeneration. Set Day Override using ▲ or ▼ buttons:

- number of days between regeneration (1 to 28); or
- "oFF"

NOTE: If softener is set up as a time clock system (ie: not meter initiated) this value will be the days between regenerations.

See table 6, page 19, for more detail on softener setup. Press NEXT to go to step 4. Press REGEN to return to previous step.

Step 4 - Next Regeneration Time (hour): Set the hour of day for regeneration using ▲ or ▼ buttons. AM/PM toggles after 12. The default time is 2:00 a.m. This display will show "REGEN" on 0 GAL if system is set for immediate regeneration. See table 6, page 19. Press NEXT to go to step 5. Press REGEN to return to previous step.

Step 5 - Next Regeneration Time (minutes): Set the minutes of day for regeneration using ▲ or ▼ buttons. This display will not be shown if system is set for immediate regeneration. Press NEXT to exit Installer Displays/Settings. Press REGEN to return to previous step.

USER DISPLAYS/SETTINGS

General Operation

When the system is operating one of two displays will be shown. Pressing NEXT will alternate between the displays. One of the displays is always the current time of day. The second display is gallons remaining. This is the number of gallons that will be treated before the system goes through a regeneration cycle. The user can scroll between the displays as desired.

If softener is a time clock system, the number of days remaining until the next regeneration will be displayed instead of gallons remaining.

If the system has called for a regeneration that will occur at the preset time of regeneration, the words "REGEN TODAY" will appear on the display.

When water is being treated (i.e. water is flowing through the system) the word "SOFTENING" flashes on the display.

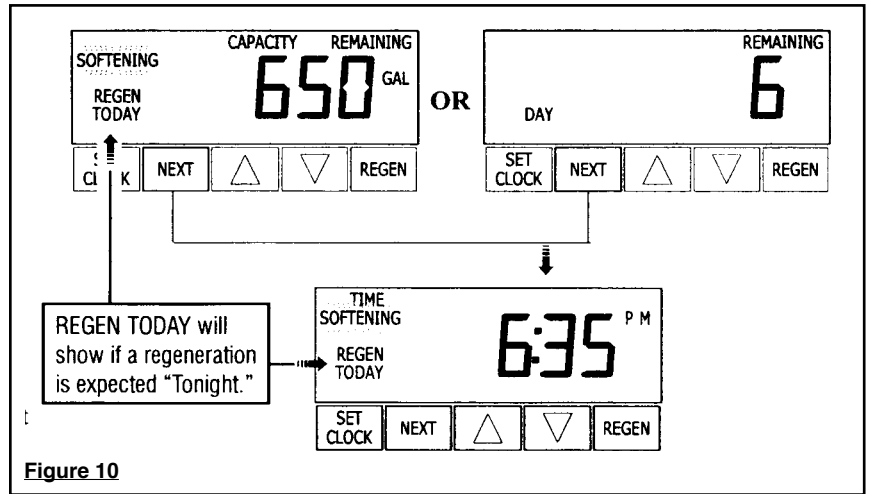

Figure 10

Regeneration Mode

Typically a system is set to regenerate at a time of low water usage. An example of a time with low water usage is when the household is asleep. If there is a demand for water when the system is regenerating, untreated water will be supplied.

When the system begins to regenerate, the display will change to include information about the step of the regeneration process and the time remaining for that step to be completed. The system runs through the steps automatically and will reset itself to provide treated water when the regeneration has been completed.

Regeneration Step #2
(shows time remaining in regen step is 8:22)

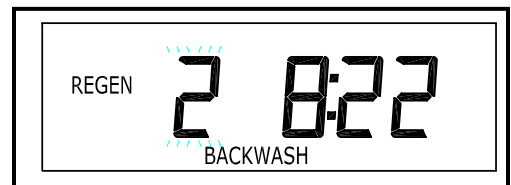

Figure 11

Manual Regeneration

Sometimes there is a need to regenerate the system, sooner than when the system calls for it, usually referred to as manual regeneration. There may be a period of heavy water usage because of guests or a heavy laundry day.

To initiate a manual regeneration at the preset delayed regeneration time, press and release "REGEN". The words "REGEN TODAY" will flash on the display to indicate that the system will regenerate at the preset delayed regeneration time. If you pressed the "REGEN" button in error, pressing the button again will cancel the request.

To initiate a manual regeneration immediately, press and hold the "REGEN" button for three seconds. The system will begin to regenerate immediately. The request cannot be cancelled. You must cycle all the way through the cycles to make it stop. PLEASE NOTE: This will reset the meter.

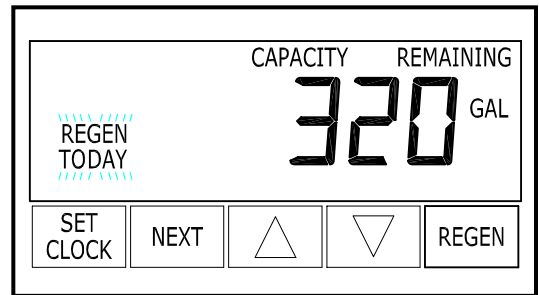

Figure 12

Note: If the salt keeper does not contain salt, fill with salt and wait at least two hours before regenerating.

WATER SOFTENER DISINFECTION

The materials of construction of your water softener will not support bacterial growth nor will these materials contaminate a water supply. However, the normal conditions existing during shipping, storage, and installation indicate the advisability of disinfecting a softener after installation, before the softener is used to treat potable water. In addition, during normal use a softener may become fouled with organic matter or in some cases, with bacteria from the water supply.

Therefore, every water softener should be disinfected after installation, some will require periodic disinfection during their normal life. Disinfect as follows:

SODIUM HYPOCHLORITE (household bleach)

5.25% SODIUM HYPOCHLORITE solutions are available

under such trade names such as Clorox, Linco, Bo Peep, White Sail and Eagle Brand Bleach. If stronger solutions are used, such as those sold for commercial laundries, adjust the dosage accordingly.

1. Dosage:
 - a. Softening resin; 1.2 fluid ounce per cubic foot of mineral (see page 18).
2. Add the required amount of hypochlorite solution to the brine well of the brine tank.
 - a. Proceed with the normal regeneration. Press regen and allow the water softener to go through a normal regeneration.

MISCELLANEOUS

1. Salt Usage: See your water conditioning professional for a recommendation on the best type of salt for your application.
2. Salt Keeper Cleaning:
 - a. Remove brine tank cover.
 - b. Scoop out as much old salt as possible.
 - c. Disconnect brine tubing from safety brine valve at brine well.
 - d. Remove safety brine valve from brine well.
 - e. Place one hand in brine well to hold overflow nut and remove 2 piece overflow.
 - f. Remove optional brine well and grid plate, if used, from brine tank.
 - g. Remove any remaining salt and/or impurities from brine tank.
 - h. Using clean water and a brush or rag, wipe and rinse inside of brine tank. Also wipe and rinse the grid plate and brine well.
 - i. Reassemble brine tank reversing steps c - f. Note: If grid plate is used and it is damaged or cracked, replace with new one.
 - j. Put brine tank in place making sure there is no debris or foreign material beneath it.
 - k. Reconnect brine tubing to safety brine valve.
 - l. Manually add 6 inches of water to the brine tank (or to approximately 1" above the grid plate, if used).
 - m. Add new salt. Important: Do not add the old salt which was removed earlier unless it is clean and not mushy. We recommend using new salt.
 - n. Follow the disinfection instructions found on page 8.
 - o. Put on brine tank cover.

TROUBLE SHOOTING

PROBLEM	CAUSE	CORRECTION
1.ERROR followed by code number		
Error Code 1001 - Unable to recognize start of regeneration	A. Control valve has just been serviced	A. Press NEXT and REGEN for 3 seconds or unplug power source jack from PC Board (black wire) and plug back in to reset control valve
Error Code 1002 - Unexpected stall	B. Foreign matter is lodged in control valve	B. Check piston and spacer stack assembly for foreign matter
Error Code 1003 - Motor ran to long, timed out trying to reach next cycle position	C. High drive forces on piston	C. Loosen drive cap assembly 1/4 turn or replace piston and spacer stack assembly
Error Code 1004 - Motor ran to long, timed out trying to reach home position	D1. Control valve piston not in home position	D1. Press NEXT and REGEN for 3 seconds or unplug power source jack (black wire) and plug back in to reset control valve
	D2. Motor not inserted fully to engage pinion, motor wires broken or disconnected, motor failure	D2. Check motor and wiring. Replace motor if necessary
	D3. Drive gear label dirty or damaged, missing or broken gear	D3. Replace or clean drive gear
	D4. Drive bracket incorrectly aligned to back plate	D4. Reset drive bracket
	D5. PC board is damaged or defective	D5. Replace PC board
	D6. PC board incorrectly aligned to drive bracket	D6. Ensure PC board is correctly snapped on to drive bracket
If other Error Codes display contact the factory		
Error Code 4003	E. Miscommunication through board or Low voltage through board	E. Unplug, re-plug in, if this does not resolve problem replace PC board
2. Control valve stalled in regeneration	A. Motor not operating B. No electric power at outlet C. Defective transformer D. Defective PC board E. Broken drive gear or drive cap assembly F. Broken piston retainer G. Broken main or regenerant piston	A. Replace Motor B. Repair outlet our use working outlet C. Replace transformer D. Replace PC board E. Replace drive gear or drive cap assembly F. Replace drive cap assembly G. Replace main or regenerant piston
3. Control valve does not regenerate automatically when REGEN button is depressed and held	A. Transformer unplugged B. No electric power at outlet C. Broken drive gear or drive cap assembly D. Defective PC board	A. Connect transformer B. Repair outlet or use working outlet C. Replace drive gear or drive cap assembly D. Replace PC board
4. Control valve does not regenerate automatically but does when REGEN button is depressed	A. By-pass valve in bypass position B. Meter connection disconnected C. Restricted/stalled meter turbine D. Defective meter E. Defective PC board F. Set-up error	A. Put control valve in service position B. Connect meter to PC board C. Remove meter and check for rotation or foreign matter D. Replace meter E. Replace PC board F. Check control valve set-up procedure
5. Time of day flashes on and off	A. Battery back-up maintains time of day up to 8 hours in event of power outage and battery is not depleted. If time of day is flashing, it indicates battery is depleted. B. Prior to 2/2007 PC Board did not have battery back-up - capacitor held time of day up to 2 hours.	A. Reset time of day and replace battery on PC Board (Lithium coin type battery 2032) B. Reset time of day.
6. Softener delivers hard water.	A. Bypass valve is open or faulty. B. No salt or low salt level in brine tank. C. Softener fails to draw brine. D. Excessive water usage. E. Insufficient brine level in brine tank. F. Resin level inadequate. G. Meter faulty. H. Raw water hardness fluctuation.	A. Close bypass valve or replace. B. Add salt to brine tank and maintain salt level above water level. C. See problem #11. D. Check gallon capacity settings. E. Check brine refill setting and refill flow restrictor for blockage. F. See problem #8. G. Test meter and clean or replace meter. H. Test raw water hardness and adjust settings to highest known hardness.
7. Unit uses too much salt.	A. Improper brine refill setting. B. Improper settings. C. Excessive water in brine tank. D. Leaking faucets, toilets, etc...	A. Check brine refill setting for proper salt dosage B. Check water hardness and reevaluate capacity setting specification C. See problem #10. D. Repair or replace those items.

TROUBLE SHOOTING

PROBLEM	CAUSE	CORRECTION
8. Loss of resin.	<ul style="list-style-type: none"> A. Backwash controller missing. B. Faulty distributor tube assembly. C. Air in water supply system. 	<ul style="list-style-type: none"> A. Install backwash controller. B. Check distributor tube assembly for cracks or holes. C. <ul style="list-style-type: none"> 1. Check for leaks in brine lines, fittings, or air check. Repair or replace. 2. Install upper distributor. 3. Ensure that water supply system has an air eliminator.
9. Softener delivers salt water.	<ul style="list-style-type: none"> A. Low water pressure. B. Excessive water in brine tank. C. Wrong size injector. 	<ul style="list-style-type: none"> A. Check incoming water pressure - Must remain at minimum of 25 psi. B. See problem #10. C. Install correct injector.
10. Excessive water in brine tank.	<ul style="list-style-type: none"> A. Plugged injector. B. Faulty piston assembly. C. Plugged or kinked drain line. D. Backwash flow controller closed off. E. Defective brine line flow control. 	<ul style="list-style-type: none"> A. Remove injector and clean ports. B. Replace piston assembly. C. Inspect drain line for kinks or plugging. D. Check backwash flow controller. E. Replace brine refill flow control.
11. Softener fails to draw brine.	<ul style="list-style-type: none"> A. Injector is plugged. B. Faulty piston assembly. C. Brine line connection leak. D. Drain line plugged creating excess back pressure. E. Drain line too long or too high F. Low inlet pressure. 	<ul style="list-style-type: none"> A. Remove injector and clean ports. B. Check piston assembly. C. Inspect brine line during refill cycle for leaks. D. Inspect drain line for blockage. E. Refer to drain line specifications. F. Increase inlet pressure to a minimum of 25 psi.
12. Continuous flow to drain.	<ul style="list-style-type: none"> A. Piston assembly failure. B. Motor failure. C. Circuit board failure. 	<ul style="list-style-type: none"> A. Replace piston assembly. B. Replace motor. C. Replace circuit board.
13. Loss of water pressure.	<ul style="list-style-type: none"> A. Iron build-up in resin. B. Resin bed fouled with sand or sediment. C. Resin bed mushing due to high amount of oxidizers in water supply (chlorine). 	<ul style="list-style-type: none"> A. See problem #14. B. Rebed softener and install sediment filter ahead of softener. C. Rebed softener. Install dechlorination system
14. Iron in softened water.	<ul style="list-style-type: none"> A. Iron has fouled resin bed. B. Iron is not in a soluble state. C. Prefilter failure. D. Iron level excessive. E. Control fails to regenerate. 	<ul style="list-style-type: none"> A. Use iron reducing resin cleaner to cleanse resin bed, and increase salt dosage or regenerate more frequently. Install an Iron Curtain System ahead of the softener. B. Test water to determine type of iron, install iron reduction system. C. Check prefilter. D. Install iron reduction system. E. See problem #4.
15. Absent or incomplete LED display	<ul style="list-style-type: none"> A. Transformer unplugged B. No electric power at outlet C. Defective transformer D. Short in meter E. Defective PC board 	<ul style="list-style-type: none"> A. Plug transformer into uninterrupted outlet B. Repair outlet or use working outlet C. Replace transformer D. Unplug meter from PC board, if LED display lights appropriately, replace meter E. Replace PC board
16. Control does not display correct time of day	<ul style="list-style-type: none"> A. Power outage > 8 hours B. Power outage < 8 hours, time of day flashing, battery depleted 	<ul style="list-style-type: none"> A. Reset time of day B. Replace lithium coin type battery on circuit board Model 2032 battery
17. No "softening" or "filtering" display when water is flowing	<ul style="list-style-type: none"> A. Bypass valve in bypass position B. Meter connection disconnected C. Restricted/stalled meter turbine D. Defective meter E. Defective PC board 	<ul style="list-style-type: none"> A. Put bypass valve in service position B. Connect meter to PC board C. Remove meter and check for rotation, clean foreign material D. Replace meter E. Replace PC board
18. Control valve regenerates at wrong time of day	<ul style="list-style-type: none"> A. Power outages > 8 hours B. Time of day not set correctly C. Time of regeneration incorrect D. Control valve set at "on 0" (immediate regeneration) E. Control valve set at NORMAL + on 0 	<ul style="list-style-type: none"> A. Reset control valve to correct time of day, replace battery if time of day flashing B. Reset to correct time of day C. Reset regeneration time D. Check control valve set-up procedure regeneration time option (see table 6, page 19) E. Check control valve set-up procedure regeneration time option (see table 6, page 19)

HELLENBRAND H-100 SERIES CONDITIONER & BRINE TANK ASSEMBLIES

Item	Description	Qty	Part #		
1	Control Center-Metered	1	60-H100-ED (see pages 13-17 for detailed components)		
	Control Center-Time Clock	1	60-H100-TC		
2	Top Diffuser	1	9-D1203		
3&4	Mineral Tank Assembly		Item 3 only	Item 4 only	Not Shown
			Mineral Tank	Distributor Assy	Tank Adapter
	H100-24 8 x 44	1	19-RT0844BL	9-93243-RT	--
	H100-32 9 x 48	1	19-RT0948BL	9-93247-RT	--
	H100-48 10 x 44	1	19-RT1044BL	9-93243-RT	--
	H100-48 10 x 54	1	19-RT1054BL	9-93253-RT	--
	H100-64 13 x 54	1	19-RT1354NAT	9-93254-RT	--
	H100-96 14 x 65	1	19-RT1465NAT	9-93272-RT	--
	H100-128 16 x 65	1	19-RT1665NAT-4	9-93272-RT	19-020-RT
	H100-160 18 x 65	1	19-RT1865NAT-4	9-TO418* *Hub & Lateral	19-020-RT
	H100-192 20 x 62	1	19-RT2062NAT-4	9-TO421* *Hub & Lateral	19-020-RT
5	Ion Exchange Resin	*	1-A4068	*See Specifications for amount	
6	Underbedding	*	1-A8072	*See Specifications for amount	
7-13a	Brine Tank Assy (18x33)-Blue	1	3-S45-1		
b	Brine Tank Assy (18x40)-Blue	1	3-S75-1		
c	Brine Tank Assy (24x41)-Black	1	3-531100302221-3		
d	Brine Tank Assy (24x50)-Black	1	3-551100302221-3		
7	3/8" x 6" Brine Line	1	2-H1023-06		
8a	18x33 Brine Tank Tank-Blue	1	2-1833BL		
b	18x40 Brine Tank Tank-Blue	1	2-1840BL		
c	24x41 Brine Tank Tank-Black	1	2-2441BK		
d	24x50 Brine Tank Tank-Black	1	2-2450BK		
9a,b	Salt Keeper Cvr 18"	1	Included with 8a,b		
c	Salt Keeper Cvr 24"	1	Included with 8c,d		
10-14a	Safety Brine Valve Assy 33"	1	2-H4700-28		
10 b,c	Safety Brine Valve Assy 41"	1	2-H4700-36		
d	Safety Brine Valve Assy 50"	1	2-H4700-46		
10	Cap, Brine Well	2	2-H7016		
11*	Safety Brine Valve	1	2-H4600		
12	Float Assembly	1	2-H4640-9.5		
13	Air Check	1	2-H4500-48		
14 a	Brine Well 33"	1	2-H1030-28S		
b,c	Brine Well 40"-41"	1	2-H1030-36S		
d	Brine Well 50"	1	2-H1030-46S		
15	2-Piece Overflow	1	2-H1018		
16 a,b	Grid Plate 18" (optional)	1	2-H1072-01		
c,d	Grid Assembly 24" (optional)	1	2-H002		
-	Owners Manual	1	73-360		

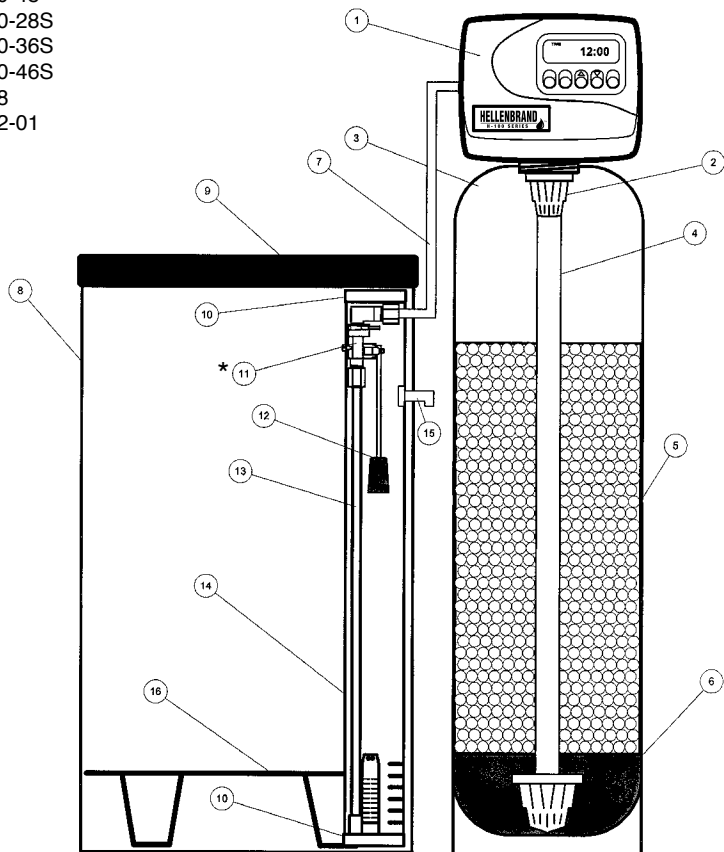
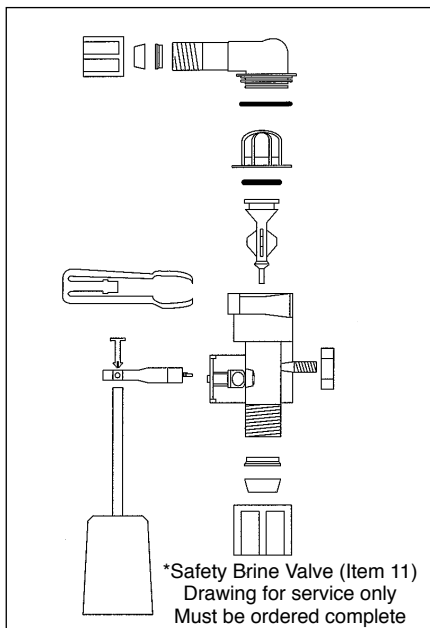

FRONT COVER AND DRIVE ASSEMBLY

ITEM NO.	ORDER NO.	DESCRIPTION	QTY.
1	15-V3175-03-L	Blue Cover Assy w/H100 Label	1
2-6	15-V3002	Drive Assy.	*
2	15-V3107-01	Motor	1
3	15-V3106-01	Drive Bracket & Spring Clip	1
4	15-V3108-09	PC Board	1
5	15-V3110	Drive Gear 12x36	3
6	15-V3109	Drive Gear Cover	1
Not Shown	15-V3186	Transformer 110V-12V	1
Not Shown	15-V3115-01	Quick Reference Guide	1

After completing any valve maintenance involving the drive assembly or the drive cap assembly and pistons, press and hold NEXT and REGEN buttons for 3 seconds or unplug power source jack from the printed circuit board (black wire) and plug back in. This resets the electronics and establishes the service piston position. The display should flash all wording, then flash the software version (ex: 154) and then reset the valve to the service position.

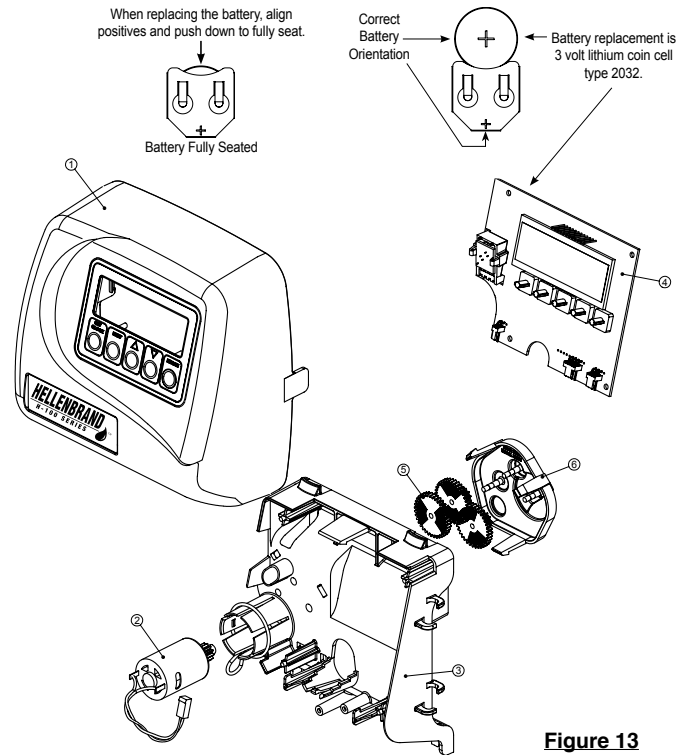

Figure 13

DRIVE CAP ASSEMBLY, DOWNFLOW PISTON, REGENERANT PISTON AND SPACER STACK ASSEMBLY

ITEM NO.	ORDER NO.	DESCRIPTION	QTY.
1	15-V3005	Spacer Stack Assy	1
2	15-V3004	Drive Cap Assy.	1
3	15-V3135	O-Ring 228	1
4a	15-V3011*	Piston Downflow Assy.	1**
4b	15-V3011-01*	Piston Upflow Assy.	1
5	15-V3174	Regenerant Piston	1
6	15-V3180	O-ring 337-tank	1
7	15-V3105	O-ring distributor tube	1
Not Shown	15-V3193	Service Wrench	1

*15-V3011 is labeled with DN and 15-V3011-01 is labeled with UP.
 Note: The regenerant piston is not used in backwash only applications.
 **Standard Option.

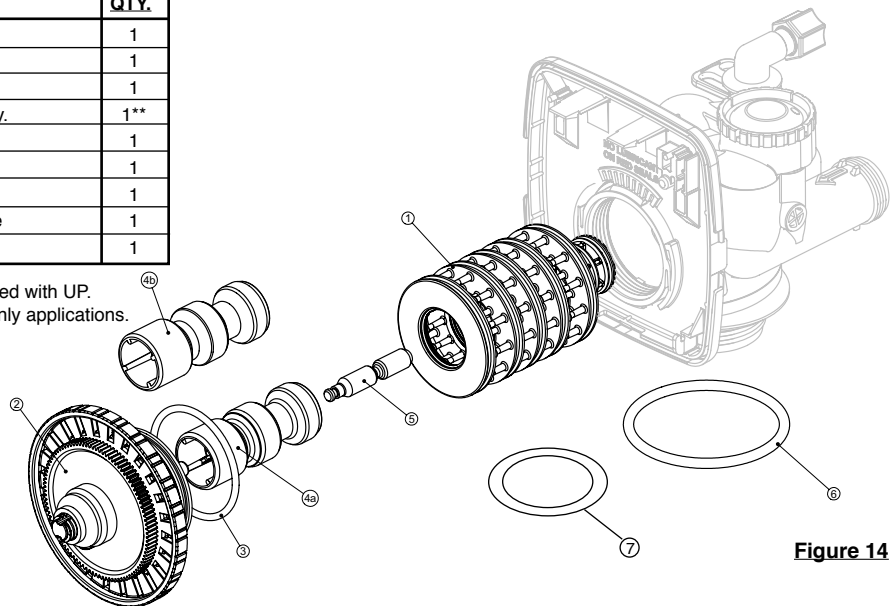

Figure 14

Do not use vaseline, oils, other hydrocarbon lubricants or spray silicone anywhere. A silicon lubricant may be used on black o-rings but is not necessary. **Avoid any type of lubricants, including silicone, on red or clear lip seals.**

After completing any valve maintenance involving the drive assembly or the drive cap assembly and pistons, press and hold NEXT and REGEN buttons for 3 seconds or unplug power source jack from the printed circuit board (black wire) and plug back in. This resets the electronics and establishes the service piston position. The display should flash all wording, then flash the software version (ex: 154) and then reset the valve to the service position.

INJECTOR CAP, INJECTOR SCREEN, INJECTOR, PLUG AND O-RING

ITEM NO.	ORDER NO.	DESCRIPTION	QTY.
1	15-V3176	Injector Cap	1
2	15-V3152	O-ring 135	1
3	15-V3177	Injector Screen	1
4	15-V3010-1Z	Injector Assy. Z Plug-Filter	1
5	15-V3010-1A	Injector Assy. A Black	1
	15-V3010-1B	Injector Assy. B Brown	
	15-V3010-1C	Injector Assy. C Violet	
	15-V3010-1D	Injector Assy. D Red	
	15-V3010-1E	Injector Assy. E White	
	15-V3010-1F	Injector Assy. F Blue	
	15-V3010-1G	Injector Assy. G Yellow	
	15-V3010-1H	Injector Assy. H Green	
	15-V3010-1I	Injector Assy. I Orange	
	15-V3010-1J	Injector Assy. J Light Blue	
	15-V3010-1K	Injector Assy K Light Green	
Not Shown	15-V3170	O-ring 011	*
Not Shown	15-V3171	O-ring 013	*

* The injector plug and the injector each contain one 011 (lower) and 013 (upper) o-ring.

See system specification, injector color on page 18 for current injector.

Note: For upflow position, injector is located in the up hole and injector plug in the down hole. For a filter that only backwashes injector plugs are located in both holes.

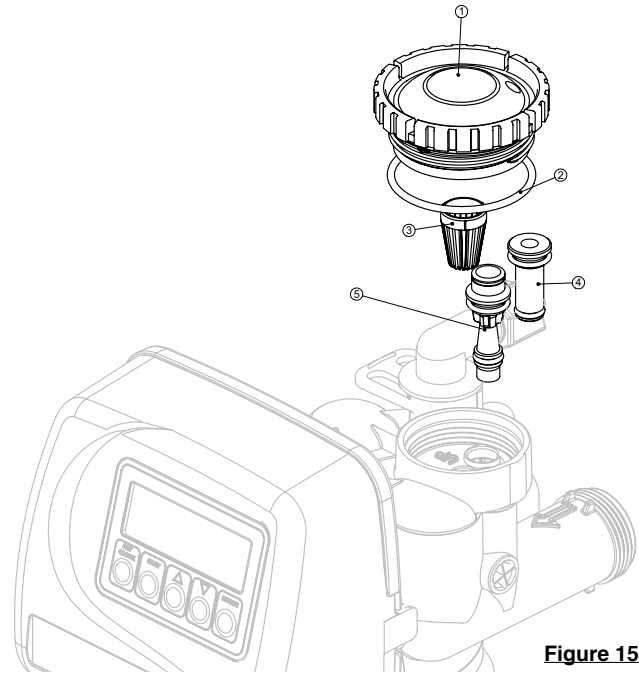

Figure 15

The nuts and caps are designed to be unscrewed or tightened by hand or with the special plastic wrench. If necessary a pliers can be used to unscrew the nut or cap. Do not use a pipe wrench to tighten or loosen nuts or caps. Do not place screwdriver in slots on caps and/or tap with a hammer.

Do not use pipe dope or other sealants on threads. Teflon tape must be used on threads of the 1" NPT connection and on the threads for the drain line connection. Teflon tape is not necessary on the nut connection nor caps because of o-rings seals.

REFILL AND REFILL PORT PLUG

Proper flow control orientation, rounded edge & text this side.

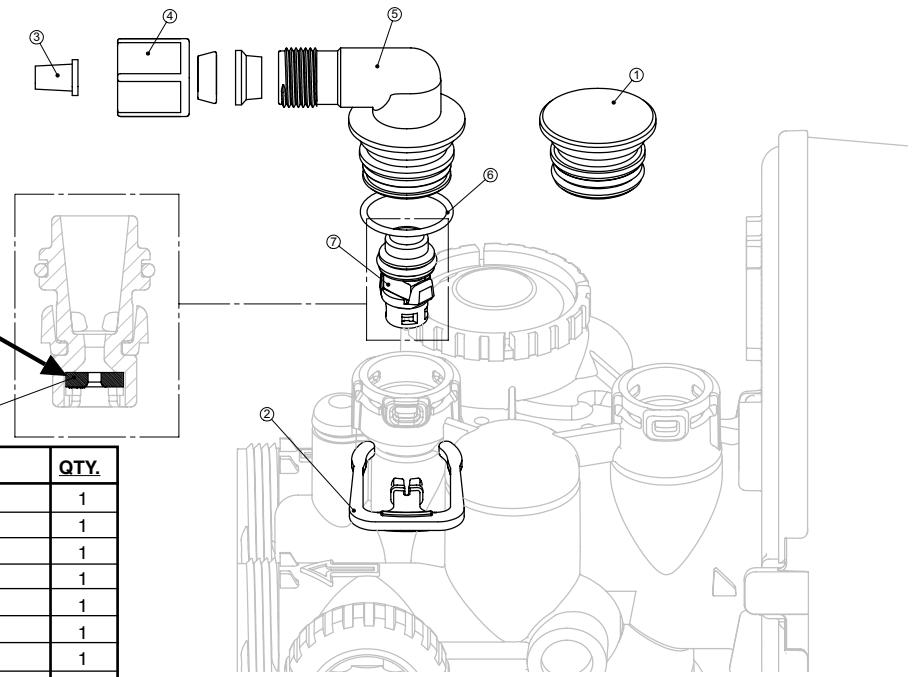

ITEM NO.	ORDER NO.	DESCRIPTION	QTY.
1	15-V3195-01	Refill Port Plug Assy.**	1
2	15-H4615	Elbow Locking Clip	1
3	15-JCP-P-6	Polytube Insert 3/8	1
4	15-JCPG-6BLK	Nut 3/8	1
5-8	15-V4613	3/8" Refill Elbow Assembly	1
5	15-H4613	Elbow Cap 3/8	1
6	15-V3163	O-ring 019	1
7	15-V3165-01*	Refill Flow Cntrl Retainer Assy.	1
8	15-V3182	Refill Flow Control Button	1
Not Shown	15-H4650	1/2" Elbow w/Nut & Insert	1

*Assembly includes item #8.

**This part is required for backwash only systems.

Figure 16

DRAIN LINE - 3/4"

ITEM NO.	ORDER NO.	DESCRIPTION	QTY.
1	15-H4615	Elbow Locking Clip	1
2	15-PKP10TS8	Polytube Insert, 5/8"	Optional
3	15-V3192	Nut, 3/4" Drain Elbow	Optional
4-6	15-V3158-01	Drain Elbow 3/4" Male Assy	1
4-6	15-V3158-02	Drain Elbow 3/4" Male Assy-No Vent	Optional
5	15-V3163	O-ring 019	1
6	15-V3159-01	DLFC Retainer Assy.	1
7	15-V3162-007	DLFC 0.7 gpm for 3/4"	1 One DLFC must be used if 3/4" fitting is used
	15-V3162-010	DLFC 1.0 gpm for 3/4"	
	15-V3162-013	DLFC 1.3 gpm for 3/4"	
	15-V3162-017	DLFC 1.7 gpm for 3/4"	
	15-V3162-022	DLFC 2.2 gpm for 3/4"	
	15-V3162-027	DLFC 2.7 gpm for 3/4"	
	15-V3162-032	DLFC 3.2 gpm for 3/4"	
	15-V3162-042	DLFC 4.2 gpm for 3/4"	
	15-V3162-053	DLFC 5.3 gpm for 3/4"	
	15-V3162-065	DLFC 6.5 gpm for 3/4"	
	15-V3162-075	DLFC 7.5 gpm for 3/4"	
	15-V3162-090	DLFC 9.0 gpm for 3/4"	
	15-V3162-100	DLFC 10.0 gpm for 3/4"	

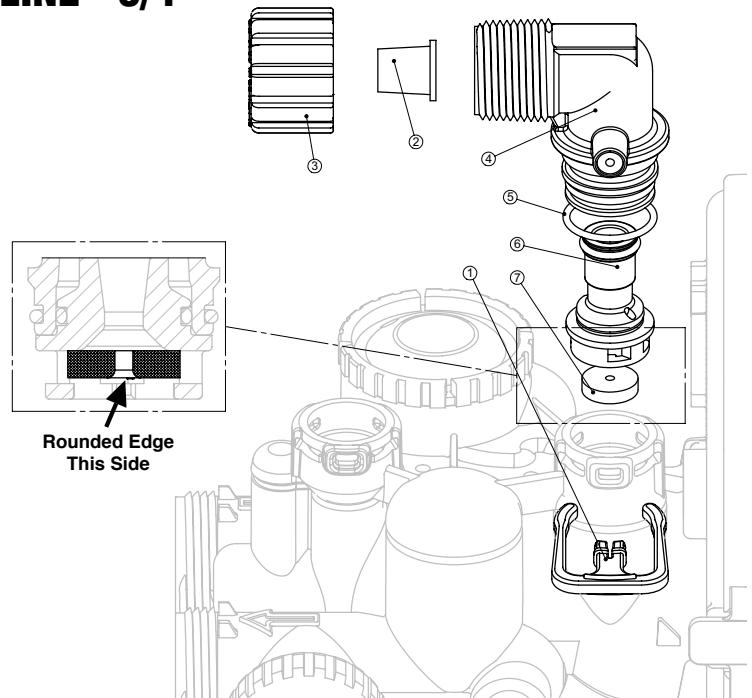

Figure 17

Systems are shipped without 3/4" nut for drain elbow (polytube installation only) and 5/8" polytube insert (polytube installation only).

See System Specifications DLFC on page 18, for correct DLFC size for your unit.

DRAIN LINE - 1"

ITEM NO.	ORDER NO.	DESCRIPTION	QTY.
1	15-H4615	Elbow Locking Clip	1
2-8	15-V3008-02	Drain Ftg, 1" Straight Assy.	1
3*	15-V3166	Drain Ftg Body, 1"	1
4*	15-V3167	Drain Ftg Adapter, 1"	1
5*	15-V3163	O-ring 019	1
6*	15-V3163	Split Ring	1
7*	15-V3151	Nut, 1" QC	1
8*	15-V3105	O-ring 215	1
9	15-V3190-090	DLFC 9.0 gpm for 1"	One DLFC must be used if 1" fitting is used
	15-V3190-100	DLFC 10.0 gpm for 1"	
	15-V3190-110	DLFC 11.0 gpm for 1"	
	15-V3190-130	DLFC 13.0 gpm for 1"	
	15-V3190-150	DLFC 15.0 gpm for 1"	
	15-V3190-170	DLFC 17.0 gpm for 1"	
	15-V3190-200	DLFC 20.0 gpm for 1"	
	15-V3190-250	DLFC 25.0 gpm for 1"	

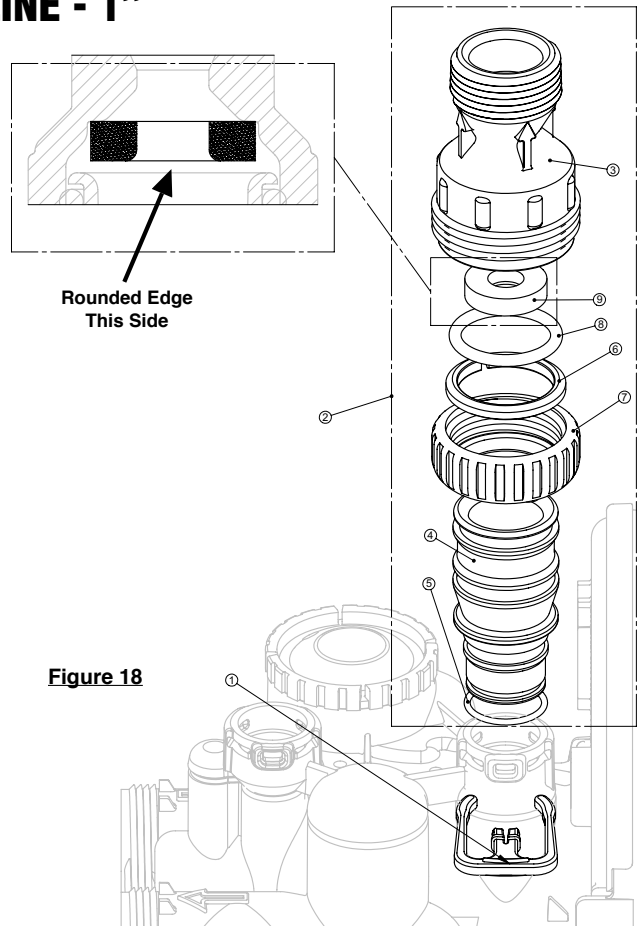

Figure 18

See System Specifications DLFC on page 18, for correct DLFC size for your unit.

The nuts and caps are designed to be unscrewed or tightened by hand or with the special plastic wrench. If necessary a pliers can be used to unscrew the nut or cap. Do not use a pipe wrench to tighten or loosen nuts or caps. Do not place screwdriver in slots on caps and/or tap with a hammer.

Do not use pipe dope or other sealants on threads. Teflon tape must be used on threads of the 1" NPT connection and on the threads for the drain line connection. Teflon tape is not necessary on the nut connection nor caps because of o-rings seals.

WATER METER AND METER PLUG

ITEM NO.	ORDER NO.	DESCRIPTION	QTY.
1	15-V3151	Nut 1" QC	1
2-4	15-V3003*	Meter Assy.	1
3	15-V3118-01	Turbine Assy.	1
4	15-V3105	O-ring 215	1
5	15-V3003-01	Meter Plug Assy.**	1

*Order number 15-V3003 includes 15-V3118-01 and 15-V3103, which are item numbers 3 & 4.

**Only used if metering is not to be done (time clock units)

The nuts and caps are designed to be unscrewed or tightened by hand or with the special plastic wrench. If necessary a pliers can be used to unscrew the nut or cap. Do not use a pipe wrench to tighten or loosen nuts or caps. Do not place screwdriver in slots on caps and/or tap with a hammer.

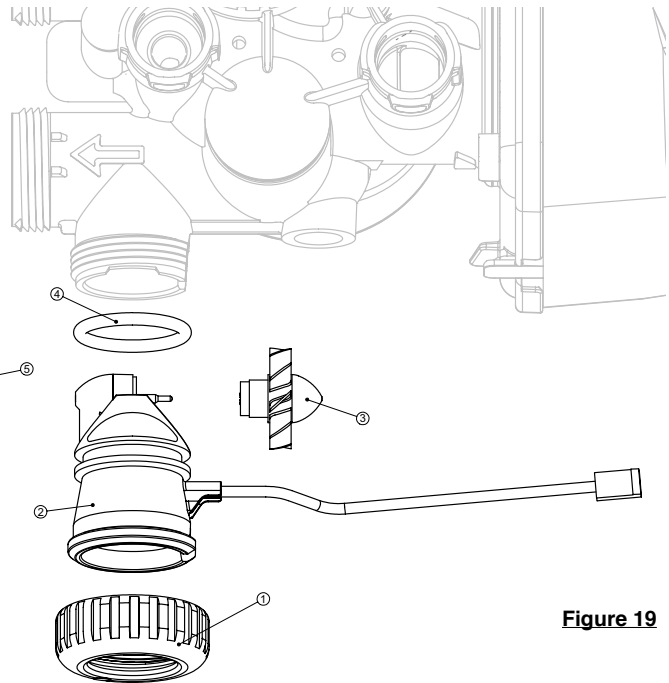
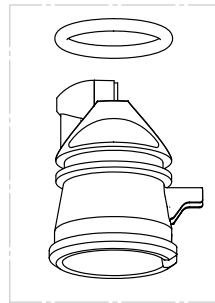

Figure 19

BYPASS VALVE

ITEM NO.	ORDER NO.	DESCRIPTION	QTY.
1	15-V3006	Complete Bypass Assembly	

NOTE: Individual Bypass Components Are Not Available, Must Order Complete Bypass Assembly.

ITEM NO.	ORDER NO.	DESCRIPTION	QTY.
Not Shown	15-V3191-01	Bypass 90° Vert. Assy.	
1	15-V3151	Nut 1" Quick Connect	2
2	15-V3150	Split Ring	2
3	15-V3105	O-Ring 215	2
11*	15-V3191-01	Bypass Verticle Adpt. Assy.	2

*11 (Not Shown)

The nuts and caps are designed to be unscrewed or tightened by hand or with the special plastic wrench. If necessary a pliers can be used to unscrew the nut or cap. Do not use a pipe wrench to tighten or loosen nuts or caps. Do not place screwdriver in slots on caps and/or tap with a hammer.

Do not use pipe dope or other sealants on threads. Teflon tape must be used on threads of the 1" NPT connection and on the threads for the drain line connection. Teflon tape is not necessary on the nut connection nor caps because of o-rings seals.

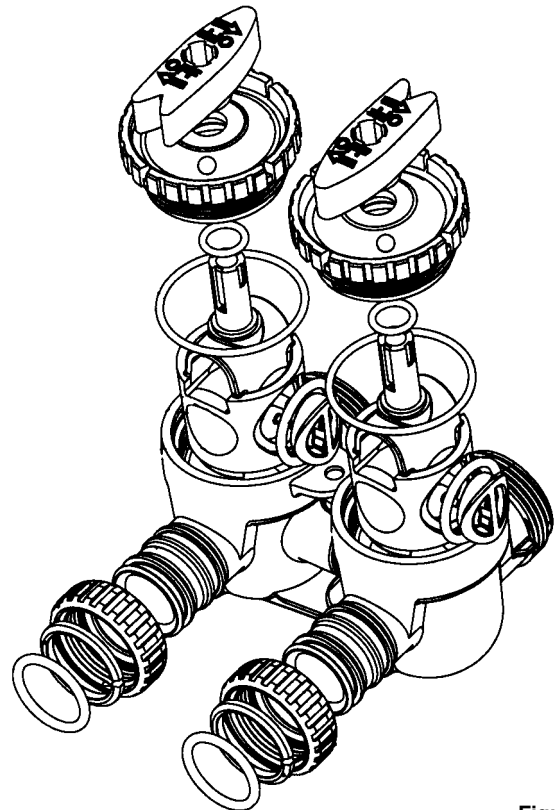
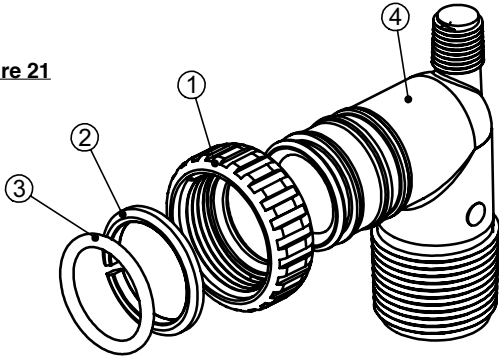

Figure 20

INSTALLATION FITTING ASSEMBLIES

ITEM NO.	ORDER NO.	DESCRIPTION	QTY.
1	15-V3151	Nut, 1" Quick Connect	2
2	15-V3150	Split Ring	2
3	15-V3105	O-Ring 215	2
4	15-V3149	Fitting, 1 PVC Male NPT Elb.	2
1-4	15-V3007	Fitting, 1" PVC Male NPT Asy.	1

Figure 21



ITEM NO.	ORDER NO.	DESCRIPTION	QTY.
1	15-V3151	Nut, 1" Quick Connect	2
2	15-V3150	Split Ring	2
3	15-V3105	O-Ring 215	2
4	15-V3189	Fitting, 3/4" & 1" PVC Solv. 90	2
1-4	15-V3007-01	Fitting, 3/4" & 1" PVC Solv 90	1

Figure 22

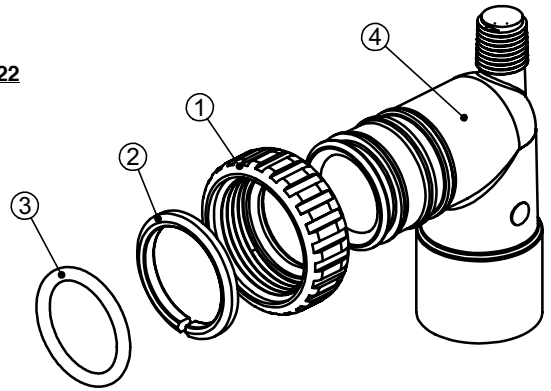

The nuts and caps are designed to be unscrewed or tightened by hand or with the special plastic wrench. If necessary a pliers can be used to unscrew the nut or cap. Do not use a pipe wrench to tighten or loosen nuts or caps. Do not place screwdriver in slots on caps and/or tap with a hammer.

Do not use pipe dope or other sealants on threads. Teflon tape must be used on threads of the 1" NPT connection and on the threads for the drain line connection. Teflon tape is not necessary on the nut connection nor caps because of o-rings seals.

ITEM NO.	ORDER NO.	DESCRIPTION	QTY.
1	15-V3151	Nut, 1" Quick Connect	2
2	15-V3150	Split Ring	2
3	15-V3105	O-Ring 215	2
4	15-V3188	Fitting, 1" Brass Sweat	2
1-4	15-V3007-02	Fitting, 1" Brass Sweat Asy	1

Figure 23

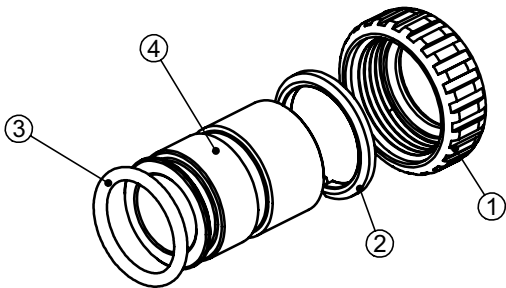

ITEM NO.	ORDER NO.	DESCRIPTION	QTY.
1	15-V3151	Nut, 1" Quick Connect	2
2	15-V3150	Split Ring	2
3	15-V3105	O-Ring 215	2
4	15-V3188-01	Fitting, 3/4" Brass Sweat	2
1-4	15-V3007-03	Fitting, 3/4" Brass Sweat Asy	1

Figure 24

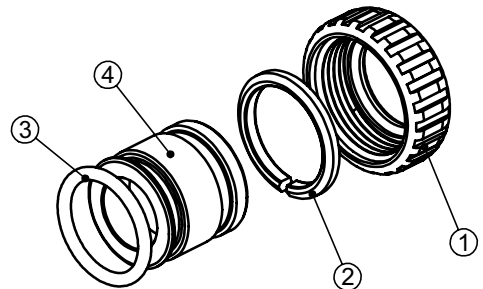

HELLENBRAND H-100 SERIES SYSTEM SPECIFICATIONS

ED -“ELECTRONIC DEMAND”

TC -“TIME CLOCK”

MODEL	H100-24TC	H100-32TC	H100-32-10TC	H100-48TC	H100-64TC	H100-96TC	H100-128TC	H100-160TC	H100-192TC
MODEL	H100-24ED	H100-32ED	H100-32-10ED	H100-48ED	H100-64ED	H100-96ED	H100-128ED	H100-160ED	H100-192ED
FACTORY PRESET MINUTES									
Backwash-1; Min**	8	8	8	8	8	8	8	8	8
Brine; Min.**	60	60	60	60	60	60	60	60	60
Backwash-2; Min**	8	8	8	8	8	8	8	8	8
Fast Rinse; Min**	4	4	4	4	4	4	4	4	4
Refill-Minutes									
-High Efficiency	3.0	4.0	4.0	6.0	8.0	12.0	16.0	20.0	24.0
-Low Salting	4.0	5.3	5.3	8.0	10.7	16.0	21.3	26.7	32.0
-Medium Salting*	5.0	6.7	6.7	10.0	13.3	20.0	26.7	33.3	40.0
-High Salting	7.5	10.0	10.0	15.0	20.0	30.0	40.0	50.0	60.0
Refill-Lbs of Salt									
-High Efficiency	4.5	6.0	6.0	9.0	12.0	18.0	24.0	30.0	36.0
-Low Salting	6.0	8.0	8.0	12.0	16.0	24.0	32.0	40.0	48.0
-Medium Salting*	7.5	10.0	10.0	15.0	20.0	30.0	40.0	50.0	60.0
-High Salting	11.3	15.0	15.0	22.5	30.0	45.0	60.0	75.0	90.0
Capacity Grains									
-High Efficiency	17,200	22,930	22,930	34,400	45,870	68,810	91,750	114,690	137,620
-Low Salting	19,980	26,650	26,650	39,970	53,300	79,950	106,600	133,250	159,900
-Medium Salting*	21,040	28,060	28,060	42,090	56,120	84,180	112,240	140,300	168,360
-High Salting	24,230	32,310	32,310	48,460	64,620	96,930	129,240	161,550	193,860
Water Usage (U.S. Gallons)***									
Normal Backwash/Longer Backwash									
-High/Max Efficiency	28/39	35/49	44/61	45/62	81/115	87/120	117/159	159/219	179/239
-Low Salting	43/51	53/64	67/80	68/82	125/151	132/157	177/208	241/286	268/313
-Medium Salting*	44/51	54/64	68/81	69/83	127/152	134/159	179/211	245/290	272/317
-High Salting	54/64	67/80	83/101	86/103	156/189	166/200	222/265	303/363	335/398
Service Flow Rate;									
Flow Rate @ 10 psi	9.8	10.1	11.3	10.5	14.2	14.4	15.1	17.3	17.8
Flow Rate @ 15 psi	13.1	13.0	14.5	14.1	18.2	19.2	20.1	22.7	23.1
Mineral; Cu Ft.	0.75	1	1	1.5	2	3	4	5	6
Underbedding;lbs	8	11	14	14	40	40	45	50	75
Mineral Tank Dimen.	8x44	9x48	10x44	10x54	13x54	14x65	16x65	18x65	20x62
Salt Keeper Dimen.	18x40	18x40	18x40	18x40	18x40	24x41	24x41	24x50	24x50
Drain Line Flow Con	1.3	1.7	2.2	2.2	4.2	4.2	5.3	7.5	7.5
Brine Line Flow Con	0.5	0.5	0.5	0.5	0.5	0.5	0.5	0.5	0.5
Injector; color	C-Violet	D-Red	D-Red	E-White	G-Yellow	H-Green	I-Orange	J-L. Blue	K-L. Green

*Factory Settings are in bold

**These times will change if High Efficiency or High Salting Setting is used - See tables 4 & 5, page 19.

*** Water usage at 40 psi inlet water pressure. Higher pressures will cause slight increases.

For high salting applications, larger brine tanks may be needed. Consult factory for recommendation.

TABLE 4 - BACKWASH NORMAL LENGTH SOFTENER

Grains Capacity/Lb NaCl		Down Flow Softener* Factory Settings			Up Flow Softener		
		6000 to 3501	3500 to 2501	2500 to 1700	6000 to 3501	3500 to 2501	2500 to 1700
Cycle Time in minutes	Backwash Normal	6	8*	8	---	---	---
	Regenerate	45	60*	75	45	60	75
	Backwash Normal	3	8*	10	6	10	12
	Rinse	3	4*	6	3	4	6
	Total	57	80*	99	54	74	93

TABLE 5 - BACKWASH LONGER LENGTH SOFTENER

Grains Capacity/Lb NaCl		Down Flow Softener			Up Flow Softener		
		6000 to 3501	3500 to 2501	2500 to 1700	6000 to 3501	3500 to 2501	2500 to 1700
Cycle Time in minutes	Backwash Normal	8	10	12	---	---	---
	Regenerate	45	60	75	45	60	75
	Backwash Normal	8	10	12	6	12	14
	Rinse	4	6	8	3	4	6
	Total	65	86	107	54	76	95

TABLE 6 - PROGRAMMING OPTIONS

Reserve Gallons	Regeneration Type	Days Override	
AUTO	NORMAL	oFF	Reserve capacity automatically estimated. Regeneration occurs when gallons capacity falls below the reserve capacity at the next Regen Set Time.
AUTO	NORMAL	1 to 24	Reserve capacity automatically estimated. Regeneration occurs at the next Regen Set Time when gallons capacity falls below the reserve capacity or the specified number of days between regenerations is reached.
20 to 50,000	NORMAL	oFF	Reserve capacity <u>not</u> automatically estimated. Regeneration occurs at the next Regen Set Time when gallons capacity reaches 0.
oFF**	NORMAL**	1 to 24**	Reserve capacity <u>not</u> automatically estimated. Regeneration occurs at the next Regen Set Time when the specified number of days between regenerations is reached.
20 to 50,000	NORMAL	1 to 24	Reserve capacity <u>not</u> automatically estimated. Regeneration occurs at the next Regen Set Time when gallons capacity reaches 0 or the specified number of days between regenerations is reached.
AUTO	On 0	oFF	Reserve capacity <u>not</u> automatically estimated. Regeneration occurs immediately when gallons capacity reaches 0. Time of regeneration will not be allowed to be set because of regeneration will always occur when gallons capacity reaches 0.
20 to 50,000	On 0	oFF	Reserve capacity <u>not</u> automatically estimated. Regeneration occurs immediately when gallons capacity reaches 0. Time of regeneration will not be allowed to be set because regeneration will always occur on 0.
AUTO	NORMAL on 0	oFF	Reserve capacity automatically estimated. Regeneration occurs when gallons capacity falls below the reserve capacity at the next Regen Set Time or regeneration occurs immediately after 10 minutes of no water usage when gallon capacity reaches 0.
AUTO*	NORMAL on 0*	1 to 24 *14	Reserve capacity automatically estimated. Regeneration occurs at the next Regen Set Time when gallons capacity falls below the reserve capacity or the specified number of days between regenerations is reached or regeneration occurs immediately after 10 minutes of no water usage when gallon capacity reaches 0.
20 to 50,000	NORMAL	1 to 24	Reserve capacity <u>not</u> automatically estimated. Regeneration occurs at the next Regen Set Time when specified number of days between regenerations is reached or regeneration occurs immediately after 10 minutes of no water usage when gallon capacity reaches 0.

* Factory settings in bold

** These settings are used for time clock systems

GENERAL SPECIFICATIONS

OPERATING PRESSURES

Minimum/Maximum25 psi-120 psi

OPERATING TEMPERATURES

Minimum/Maximum40° - 110° F

METER

Accuracy.....±5%

Flow Rate Range.....0.25 - 27 GPM

Gallon Range20 - 50,000

DIMENSIONS

Drain Line3/4" or 1" NPT

Brine Line3/8" Poly Tube

Electrical Current Draw and Voltage0.5A 110v

Compatible with the following regenerants or chemicals: Sodium chloride, potassium permanganate, sodium bisulfite, sodium hydroxide, hydroxide, hydrochloric acid, chlorine and chloramines.

H100 SERIES WATER SOFTENERS LIMITED WARRANTY

Hellenbrand, Inc., warrants to the original consumer purchaser that the H100 Series and the parts listed below will be free from defects in material and/or workmanship from the date of the original installation for the following time periods:

For a Period of FIVE YEARS: The control valve including electrical parts, internal parts, and valve body.

For a Period of TEN YEARS: Mineral tanks, 6" Diameter - 13" Diameter.

For a Period of FIVE YEARS: Mineral tanks, 14" - Up.

For a Period of FIVE YEARS: The salt storage/cabinet tank.

For a Period of ONE YEAR: Any other component.

Any parts used for replacement are warranted for the remainder of the original warranty period applicable to the part.

THIS WARRANTY IS EFFECTIVE TO THE ORIGINAL CONSUMER PURCHASER ONLY, AND ONLY AS LONG AS THE H100 SERIES REMAINS AT THE ORIGINAL INSTALLATION SITE.

No sales representative, distributor, agent, dealer, reseller or any other person is authorized to make any other warranty on behalf of Hellenbrand, Inc. Upon expiration of the applicable warranty period(s), Hellenbrand, Inc., shall have no further liability related to the products/parts to which the warranty period(s) apply, except with respect to valid warranty claims asserted during the appropriate warranty period(s).

If a part described above becomes defective within the specified warranty period, you should notify your H100 Series sales representative and arrange a time during normal business hours for the inspection of the water conditioner at the original installation site. Any part found defective within the terms of this warranty will, at Hellenbrand, Inc.'s option, be repaired or replaced. You are responsible for freight from our factory and local service charges. This paragraph sets forth the exclusive remedy for any valid warranty claims against Hellenbrand, Inc.

THIS WARRANTY DOES NOT COVER defects caused by sand, sediment or bacteria fouling, accident, fire, flood, Act of God, misuse, misapplication, neglect, alteration, installation or operation contrary to Hellenbrand, Inc.'s printed instructions, or installation, repair or service by anyone other than Hellenbrand, Inc., or an authorized Hellenbrand reseller.

As a manufacturer, we do not know the characteristics of your water supply or the purpose for which you are purchasing this water conditioner. Please understand that the quality of water supplies may vary seasonally or over a period of time, and that your water usage rate may vary as well. Water characteristics can also change considerably if your water conditioner is moved to a new location. For these reasons, we assume no liability for the determination of the proper equipment necessary to meet your requirements and we do not authorize others to assume such obligations for us.

REMEDIES FOR DEFECTS OR FAILURES, TO THE EXTENT PERMITTED BY APPLICABLE LAW, ARE LIMITED TO THE REMEDIES PROVIDED IN THIS WARRANTY. ANY EXPRESS WARRANTY NOT PROVIDED HEREIN AND ANY WARRANTY WHICH MIGHT ARISE BY IMPLICATION OR OPERATION OF LAW, WHETHER FROM THE SELLER AND/OR MANUFACTURER OF THIS PRODUCT, IS HEREBY EXCLUDED AND DISCLAIMED, TO THE EXTENT ENFORCEABLE UNDER APPLICABLE LAW, INCLUDING WITHOUT LIMITATION IMPLIED WARRANTIES OF MERCHANTABILITY, FITNESS FOR ANY PARTICULAR PURPOSE OR NON-INFRINGEMENT, OR ANY WARRANTIES ARISING FROM COURSE OF PERFORMANCE, COURSE OF DEALING, OR FROM USAGES OF TRADE.

UNDER NO CIRCUMSTANCES SHALL HELLENBRAND, INC., BE LIABLE TO THE ORIGINAL CONSUMER PURCHASER OR TO ANY OTHER PERSON FOR ANY INCIDENTAL, SPECIAL OR CONSEQUENTIAL DAMAGES OR FOR ANY OTHER LOSS, DAMAGE, OR EXPENSE OF ANY KIND, INCLUDING LOSS OF PROFITS, WHETHER ARISING OUT OF BREACH OF WARRANTY, BREACH OF CONTRACT, IN TORT OR OTHERWISE, AND REGARDLESS OF WHETHER HELLENBRAND, INC., WAS AWARE OF THE POSSIBILITY OF SUCH LOSS. THESE LIMITATIONS WILL APPLY REGARDLESS OF ANY FAILURE OF ESSENTIAL PURPOSE OF ANY LIMITED REMEDY.

Some states do not allow limitations on how long an implied warranty lasts or exclusions or limitations of incidental or consequential damages, so the above limitations or exclusions may not apply to you. This warranty gives you specific legal rights, and you may also have other rights which vary from state to state.