

Hellenbrand[®]

E³



Owner's Manual

Manufactured by:
HELLENBRAND, INC.

Web: www.hellenbrand.com • Email: info@hellenbrand.com

109317 Rev C
3/01/18-LBRY
©2011-2018

This owner's manual is designed to assist owners and installers with the operation, maintenance and installation of your new water softener. It is our sincere hope that this manual is clear, concise and helpful to both owner and installer. We have included detailed instructions on general operating conditions, pre-installation and installation instructions, start-up, and timer and meter programming. We have included a troubleshooting guide, service instructions and parts diagrams to assist you.

Owners will appreciate the simplified, illustrated format for operation, programming and troubleshooting. **In the event that you need professional assistance for servicing your water softener, please contact the dealer who installed this system.**

TABLE OF CONTENTS

Job Specification Sheet.....	Page 2
Operating Conditions.....	2
Soft Water Basics.....	3
Frequently Asked Questions.....	3
Pre-Installation Check List.....	4
Installation Instructions.....	5
Programming.....	6
Water Softener Disinfection.....	6
Displays/Settings.....	7-8
Water Softener Draining Procedure.....	9
Softener Setup Quick Reference.....	10
Diagnostics.....	12
Valve History.....	13
Trouble Shooting.....	14-15
Parts Diagrams.....	16-19
Specifications.....	20-24
Warranty.....	24

JOB SPECIFICATION SHEET

MODEL NO. _____

*WATER TEST AT TIME OF INSTALLATION

_____ Hardness CaCO ₃ (gpg)	_____ Other _____
_____ Iron (ppm)	_____ Other _____
_____ pH	_____ Other _____

*SIZING INFORMATION

All Water is Softened Except:

_____ Rear Hose Bib _____ Front Hose Bib _____ Kitchen Cold _____ Toilets _____ All Cold
 _____ Other _____

The average family uses 50 gallons per person daily for all water uses in the home, about 40 gallons per person daily if soft water is not supplied to the toilets, and about 30 gallons per person daily if only hot water is softened.

_____ Daily Water Usage (Gallons/Person)
 x _____ Family Size (Number of people in family)
 = _____ Total Gallons Per Day
 x _____ Grains Per Gallon of Total Compensated Hardness
 (Note: Add 3 grains per gallon of hardness for each ppm iron for total compensated hardness)
 = _____ Total Grains Per Day

*INSTALLATION DATE _____

*SERIAL NUMBER _____

NOTES _____

OPERATING CONDITIONS

Your water conditioner has been designed to adequately handle up to 100 grains per gallon of hardness as well as up to 2 ppm of Ferrous Bicarbonate Iron. This is iron that is dissolved in an oxygen-free water supply. It is not visible to the eye in a freshly drawn sample because the water appears clear. But upon standing in contact with air, the ferrous iron will become oxidized to the ferric state and start to precipitate as a reddish brown flock. It can then be seen and if allowed to remain in the supply will cause discolored water. In order for your conditioner to remove the iron, air (oxygen) must be kept from coming in

contact with water until after it has been passed through the water conditioner. In some cases, additional equipment may be required to treat water supplies having special characteristics, such as: oxidized iron, iron bacteria, low pH, taste and odors, etc. If any question should exist, contact your dealer.

This conditioner is not intended to be used for treating water that is microbiologically unsafe or of unknown quality without adequate disinfection before or after the system.

SOFT WATER BASICS

Hardness

Excess amounts of calcium and magnesium in water produce hardness. A water softener removes the majority of calcium and magnesium to produce softened water.

Hardness is measured in terms of grains. (This grain weight is derived from the average weight of a dry grain of wheat.) When your water is tested the grain hardness is calculated and expressed as grains per gallon (gpg). This calculation, as well as the number of people in your household will help determine what type and size of water softener will most efficiently soften your water.

Your water softener contains an ion exchange media (sometimes called resin) which removes the hardness from water as it flows through the softener tank. Eventually so much hardness collects on the exchange media that the softener can no longer soften water. At this point it is considered "exhausted". Regeneration is now necessary.

Regeneration

To regenerate the exchange media, it must be rinsed with a brine (salt) solution. This removes the hardness from the exchange media and replaces it with sodium. The exchange media is then ready to remove hardness from water. The hardness minerals and excess brine solution are rinsed down the drain.

During the regeneration cycle the softener is also backwashed. This reversing of the normal flow of water serves to remove sediment which may have accumulated during the softening process due to the filtering action of the exchange media. Backwashing also loosens and fluffs up the bed of exchange media to insure that during regeneration the brine solution will come into contact with all the media.

Maintenance of Your Softener

Salt: Salt to a softener is what gasoline is to a car. Not only must a softener have salt, but it should be the proper type to insure efficient recharging of the unit. Ask your dealer what type of salt may best suit your needs. Always have an adequate supply of salt on hand. Check the salt level of your salt keeper periodically. Fill the tank approximately three-fourths full, with a minimum of 12" of salt.

Cleaning Salt Keeper: Salt keeper may require periodic cleaning. Inspect the salt keeper at least once a year for buildup of insoluble materials. It is recommended to periodically clean the salt keeper no matter what kind of salt you are using. See page 9, miscellaneous #2 for details on cleaning.

REMEMBER: Salt is the fuel to run your water softener. Buy the **best clean salt available**.

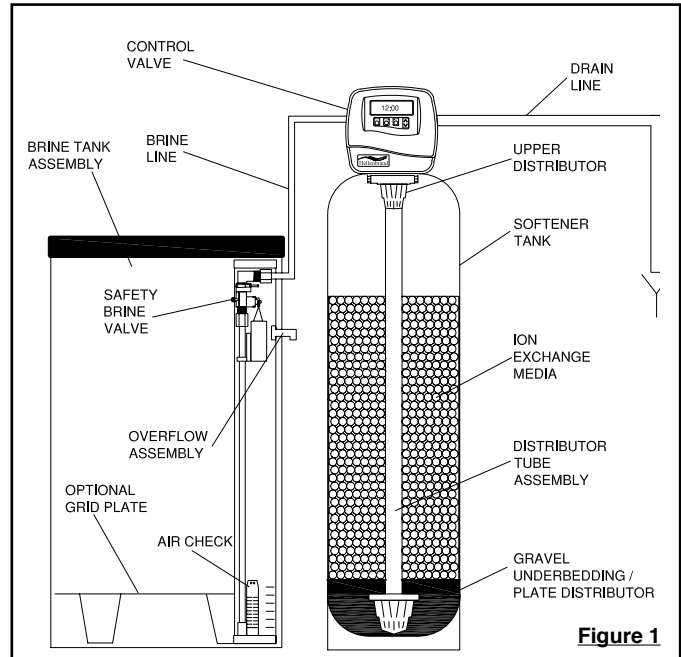

FREQUENTLY ASKED QUESTIONS

- 1. Do I still use the same amount of soap in the dishwasher and clothes washer and showers now that I have a water softener?**
No, the Water Quality Association states soft water can save up to 55% on detergent use. Start with using half the amount of detergent previously used, this can be adjusted up or down based on preference. Soft water helps fabrics last longer, because hardness minerals combined with soap can make fabric fibers brittle.
- 2. What is the health impact of drinking soft water?** The sodium added to water by a softening is a non-issue most of the time, even for people on a sodium-restricted diet. One could soften up to 75 grains per gallon water with sodium chloride and still be well within the US Food and Drug Administration's guidelines for a "Low Sodium" beverage. People on a sodium-restricted diet should consult their physician.
- 3. Should I use soft water for my plants?** Some plants may be sensitive to even minute amounts of sodium. Suggest using hard water for watering plants, often a kitchen cold faucet is plumbed for hard water or the outside faucets are usually plumbed for hard water. If not, you can place your softener on bypass and fill water containers at the closest sink. Water from a reverse osmosis system can always be used to water plants.
- 4. Will water spots disappear now that I have soft water?** Water spots caused by hardness scale will disappear with a functioning water softener. However, other natural minerals dissolved in the water may cause spotting in high enough concentrations. These mineral spots will be much easier to wipe away compared to hardness spotting.
- 5. Will soft water cause my water or ice cubes to look or taste different?** Most people can tell the difference in taste between hard and soft water, it is a personal preference. Ice cubes will appear the same, they may look cloudy due to air in water or dissolved minerals, and this will not change because they are made with softened water. A reverse osmosis drinking water system will provide clearer ice cubes.

PRE-INSTALLATION CHECK LIST

(All electrical & plumbing should be done in accordance to all local codes)

Water Pressure: A minimum of 25 pounds of water pressure (psi) is required for regeneration. Maximum 120 psi.

Water Quality: On rural water supplies there is often a problem with sand or sediment in the water. (This problem occasionally occurs in public water supplies.) If the water is not filtered before being softened, the sand and sediment will plug up the water softener restricting the flow through the resin bed. This problem often requires rebedding of the mineral tank. **Note:** Well and/or pump problems affecting the operation of the softener are repairs that are not covered under warranty. To prevent these unnecessary, and expensive repairs that are not covered under warranty, Hellenbrand recommends installing an in-line filter system ahead of softeners.

Electrical: A continuous 110 volt 60 cycle current supply is required. Make certain the current supply is uninterrupted and cannot be turned off with another switch. All electrical connections must be connected per local codes. **Surge protection is recommended with all electronic controls.**

Existing Plumbing: Condition of existing plumbing must be free from lime and iron build-up. Piping that is built-up heavily

with lime and/or iron must be replaced. If piping is blocked with iron, additional equipment must be installed ahead of the water conditioner to correct the problem.

Drain Line: The conditioner should be located close to a drain. Avoid overhead drain lines if possible to prevent back pressure on the brine injector. Overhead drains are not to exceed 8 feet above the floor and no more than 20 feet in length. The pipe size for the drain line should be a minimum of 3/4". Backwash flow rates in excess of 10 gpm or length in excess of 20' require 1" drain line. Verify connection to sanitary waste system is through proper air gap.

Bypass Valves: Always provide for the installation of a bypass valve.

Softening: It is recommended that the conditioner be installed to soften both the hot and cold water supply. A separate hard water faucet may be plumbed for drinking purposes if you desire. Outside faucets should be left on hard water.

Caution: Water temperature is not to exceed 110°F; the conditioner cannot be subject to freezing conditions, or to a vacuum due to loss of pressure (such as a water main break).

BYPASS VALVE OPERATION

NORMAL OPERATION Softening - Filtering

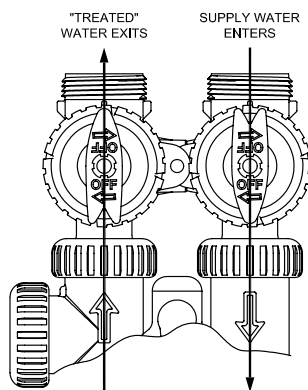

Figure 2

BYPASS OPERATION

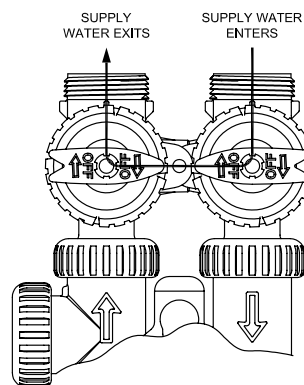

Figure 3

DIAGNOSTIC MODE

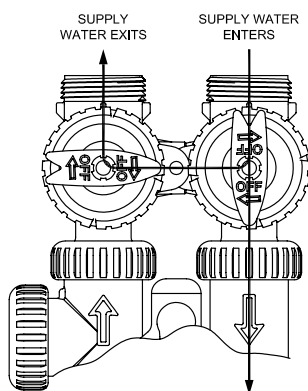

Figure 4

SHUT OFF MODE

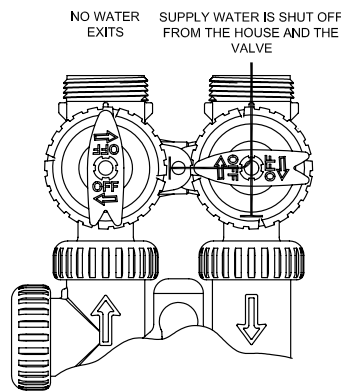

Figure 5

INSTALLATION INSTRUCTIONS

(All electrical & plumbing should be done in accordance to all local codes)

- Do not use vaseline, oils, other hydrocarbon lubricants or spray silicone anywhere. A silicon lubricant may be used on black o-rings but is not necessary. **Avoid any type of lubricants, including silicone, on red or clear lip seals.**
 - Do not use pipe dope or other sealants on threads. Only teflon tape may be used on threads. Teflon tape is not necessary on the nut connection or caps because of radial o-ring seals.
 - The pipe size for the drain line should be a minimum of 3/4". Backwash flow rates in excess of 10 gpm or length in excess of 20' require 1" drain line.
1. Place the conditioner where you want to install it, making sure it is on a clean, level and firm base.
 2. Do all necessary plumbing (inlet to inlet, outlet to outlet and drain line to drain). The control valve, fittings and/or bypass are designed to accommodate minor plumbing misalignments but are not designed to support the weight of a system or the plumbing.
 3. When assembling the installation fitting package (inlet and outlet), connect the fitting to the plumbing system first and then attach the nut, split ring and o-ring. Heat from soldering or solvent cements may damage the nut, split ring or o-ring. Solder joints should be cool and solvent cements should be set before installing the nut, split ring and o-ring. Avoid getting primer and solvent cement on any part of the o-rings, split rings, bypass valve or control valve.
 4. **A jumper ground wire should be installed between the inlet and outlet pipe whenever the metallic continuity of a water distribution piping system is interrupted. Install grounding strap on metal pipes.**
 5. The drain connection may be made using either 5/8" polytube (See figure 6a) or a 3/4" female adapter. If soldering, joints near the drain must be done prior to connecting the drain

line flow control fitting. Leave at least 6" between the drain line control fitting and solder joints when soldering pipes that are connected on the drain line control fitting. Failure to do this could cause interior damage to the drain line flow control fitting.

6. The brine refill flow control assembly is installed in an easy to access refill elbow located on top of the control valve. The refill flow control assembly is attached to the control valve with a locking clip. The locking clip allows the elbow to rotate 270 degrees so the outlet can be orientated towards the salt keeper.
7. Connect the brine line found in the salt keeper to the brine connection on the control valve. The control valve has a standard refill elbow to which a 3/8" flexible tube can be connected, see figure 6a, page 5. (An optional elbow can be ordered which accommodates a 1/2" flexible tube for a high regenerant draw rate situation). Both elbows use the same refill flow control and retainer. Do not connect the other end of the brine line to the safety brine valve in the salt keeper at this time. Make sure the floor is clean beneath the salt tank and that it is level and smooth. No grid is required with standard brine tank as softener is programming as prefill.
8. A 1/2" (inside diameter) gravity drain line should be connected to the overflow elbow on the side of the brine tank and run to a drain below the level of the elbow. This overflow drainage system provides protection from water damage in the event of a brine shut-off malfunction. Tubing is not provided to do this.

In all cases where an overflow could result in water damage for various reasons, this overflow protection must be used. Do not connect the tubing to the drain line on the control valve discharge line and do not run this line above the overflow elbow height at any point. Provide air gap.



Figure 6a

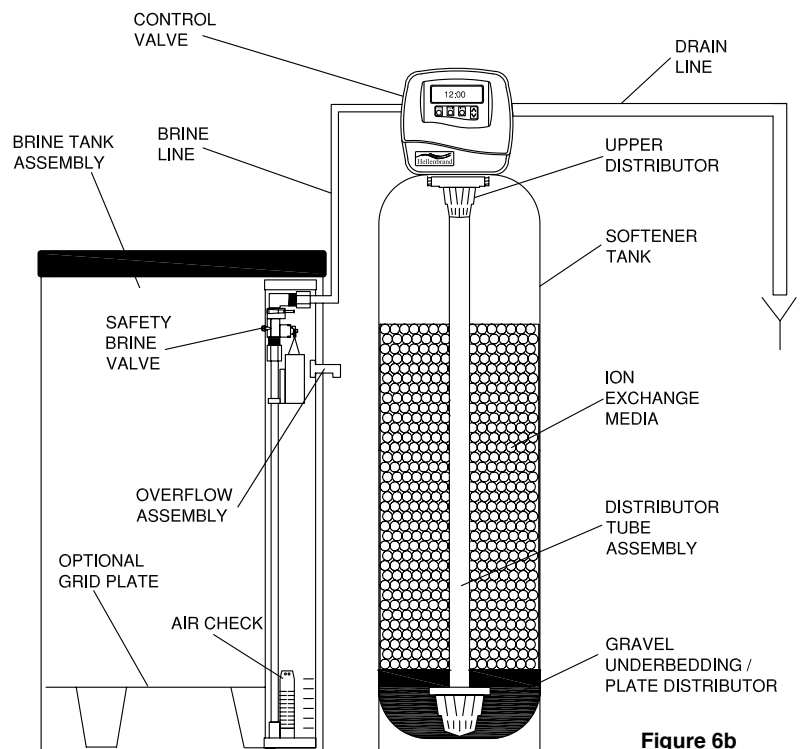

Figure 6b

PROGRAMMING

General Information

The Hellenbrand E³ control valve is the “brain” of your water softener. It consists of the valve body and powerhead with solid state microprocessor.

The display panel (see Figure 7) consists of the LED display, power light, and five push buttons which are used in displaying and programming the water softener settings.

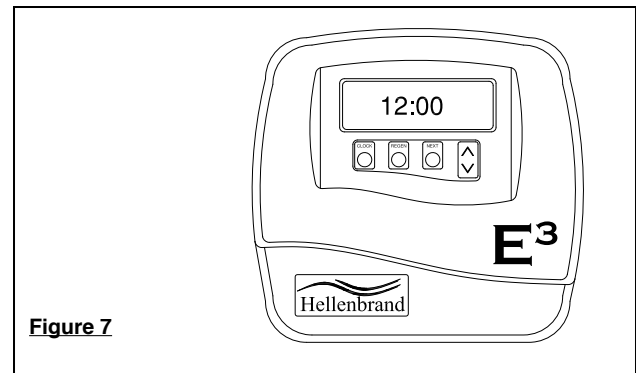

INITIAL START UP

The initial start up will probably be done by the technician installing the softener system. If not, the following instructions will step you through the process.

1. Complete all plumbing connections: inlet, outlet, drain line and brine line. Do not add salt at this time.
2. Place the bypass valve in the bypass position. (See figure 3 page 4) Turn on the main water supply. Open a cold soft water faucet to flush the piping of any air and/or foreign material. Run until the water is clear.
3. Manually add 6 inches of water to the salt keeper.
4. Now plug the transformer into a 110-volt receptacle. (Be certain the outlet is uninterrupted.) Within 5 seconds the control will automatically align itself into the softening mode and the display will flash 12:00 (AM). (Figure 7, page 6).
5. Set the time of day (figure 8, page 7).
6. Push REGEN button and hold it down for 3 seconds. The system will advance to the “Fill” position. (Note: If the system is not programmed as “brine refill first”, “Backwash” will display first). Keep pushing REGEN button until “Rinse” shows in the lower right hand corner of display. Slowly place the by-pass into the “diagnostic mode” (see fig 4, page 4). Run water to the drain until it runs clear. Return the by-pass valve to the by-pass position (fig 3, page 4). Push REGEN button one more time, “Time” will appear in upper left hand corner of display.
7. Once again, push REGEN button and hold down for 3 seconds. Keep pushing REGEN button until “Backwash” appears. Slowly place the by-pass valve into the “Diagnostic Mode” 1/2 way. Allow water to slowly fill the mineral tank. When a solid stream of water starts

8. coming out of the drain line, open the by-pass inlet valve all the way and allow to run out the drain until water clears. Then slowly place the by-pass into the “normal operation” mode by opening the outlet side of by-pass valve, figure 2, page 4.
9. Press the regen button one more time. LED display should say “BRINE”. Loosen the brine line from the top of the safety brine valve in the brine tank. Place finger over the end of the tube to check for suction. If no suction, see trouble-shooting guide. (See #11, Page 11) If proper suction, reattach brine tube to safety brine valve, and allow it to draw water down to the bottom of the air check, (figure 6b, page 5).
10. Press REGEN button once again. LED will once again display “BACKWASH”. Keep in backwash until water once again runs clear at the drain.
11. Press REGEN button again. LED will display “RINSE”. Allow rinse cycle to run its full circle. While the rinse cycle is finishing, this would be a good time to load your brine tank with salt. The brine tank does not require a grid because softener is programmed to fill brine tank with appropriate volume of water 2 hours prior to regeneration.
12. Once the rinse cycle has finished the softener control will return to the softening cycle. The LED screen will indicate “TIME”.
13. Next set your softeners water hardness, days override and regeneration time settings (see figure 9, page 7).

Your programming is now complete.

WATER SOFTENER DISINFECTION

The construction materials of your water softener will not support bacterial growth nor will these materials contaminate a water supply. However, the normal conditions existing during shipping, storage, and installation indicate the advisability of disinfecting a softener after installation, before the softener is used to treat potable water. In addition, during normal use a softener may become fouled with organic matter or in some cases, with bacteria from the water supply.

Therefore, every water softener should be disinfected after installation, some will require periodic disinfection during their normal life. You have two choices for disinfection as follows:

- A. SODIUM HYPOCHLORITE (household bleach)
5.25% SODIUM HYPOCHLORITE solutions are available under such trade names such as Clorox, Linco, Bo Peep,

White Sail and Eagle Brand Bleach. If stronger solutions are used, such as those sold for commercial laundries, adjust the dosage accordingly.

1. Dosage:
 - a. Softening resin; 1.2 fluid ounce per cubic foot of resin.
2. Add the required amount of hypochlorite solution to the brine well of the brine tank.
 - a. Proceed with the normal regeneration. Press REGEN and allow the water softener to go through a normal regeneration.
- B. EPA and NSF approved Sani-System by Pro Products. This can be purchased from your water treatment provider or at: <http://proproducts.com/products/sani-system>.

SET TIME OF DAY

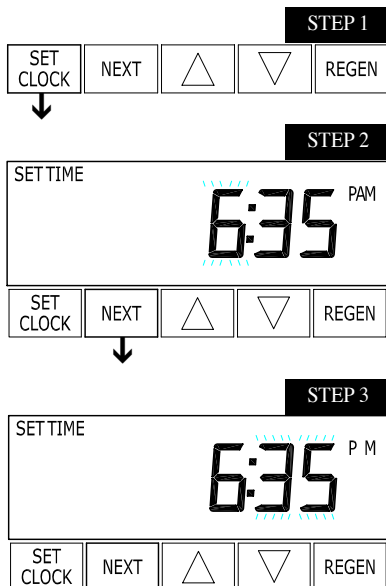

Figure 8

Step 1 - Press SET CLOCK.

Step 2 - Current Time (hour): Set the hour of the day using ▲ or ▼ buttons. AM/PM toggles after 12. Press NEXT to go to step 3.

Step 3 - Current Time (minutes): Set the minutes of day using ▲ or ▼ buttons. Press NEXT to exit Set Clock. Press REGEN to return to previous step.

Power Loss - Lithium battery on circuit board provides up to 8 hours of time clock backup during power outages. After 8 hours, only the time of day needs to be reset, all other values are stored in non-volatile memory. If a power loss last less than 8 hours and time of day is flashing, replace coin type 2032 battery. Do not forget to reset for daylight savings time.

INSTALLER DISPLAYS/SETTINGS

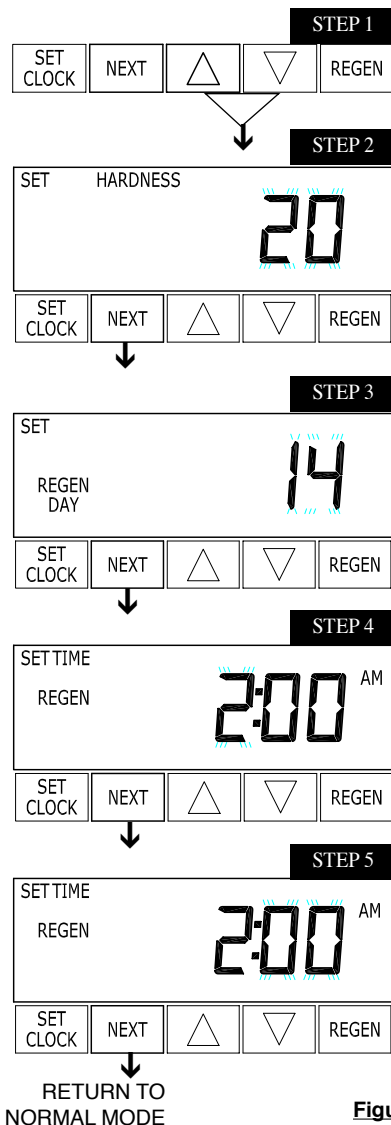

Figure 9

Step 1 - Press NEXT and ▲ simultaneously for 3 seconds.

Step 2 - Hardness: Set the amount of total compensated hardness in grains (hardness as calcium carbonate) per gallon using ▲ or ▼ buttons. The default is 20 with value ranges from 1 to 150 in 1 grain increments. Note: The grains per gallon should be increased if soluble iron needs to be reduced. Add 3 grains of hardness for each ppm of iron present. If this display shows nA -, then system is either set-up in "time clock" or "filter" modes. (See table 6, page 19). Press NEXT to go to Step 3. Press REGEN to exit Installer Displays/Settings.

Step 3 - Day Override: This sets the number of days between regenerations. If value is set to "oFF" regeneration initiation is based solely on gallons used. If value is set as a number (allowable range from 1 to 28) a regeneration initiation will be called for on that day even if sufficient number of gallons were not used to call for a regeneration. Set Day Override using ▲ or ▼ buttons:

- number of days between regeneration (1 to 28); or
- "oFF"

NOTE: If softener is set up as a time clock system (ie: not meter initiated) this value will be the days between regenerations.

See table 6, page 19, for more detail on softener setup. Press NEXT to go to step 4. Press REGEN to return to previous step.

Step 4 - Next Regeneration Time (hour): Set the hour of day for regeneration using ▲ or ▼ buttons. AM/PM toggles after 12. The default time is 2:00 a.m. This display will show "REGEN" on 0 GAL if system is set for immediate regeneration. See table 6, page 19. Press NEXT to go to step 5. Press REGEN to return to previous step.

Step 5 - Next Regeneration Time (minutes): Set the minutes of day for regeneration using ▲ or ▼ buttons. This display will not be shown if system is set for immediate regeneration. Press NEXT to exit Installer Displays/Settings. Press REGEN to return to previous step.

USER DISPLAYS/SETTINGS

General Operation

When the system is operating one of two displays will be shown. Pressing NEXT will alternate between the displays. One of the displays is always the current time of day. The second display is gallons remaining. This is the number of gallons that will be treated before the system goes through a regeneration cycle. The user can scroll between the displays as desired.

If softener is a time clock system, the number of days remaining until the next regeneration will be displayed instead of gallons remaining.

If the system has called for a regeneration that will occur at the preset time of regeneration, the words "REGEN TODAY" will appear on the display.

When water is being treated (i.e. water is flowing through the system) the word "SOFTENING" flashes on the display.

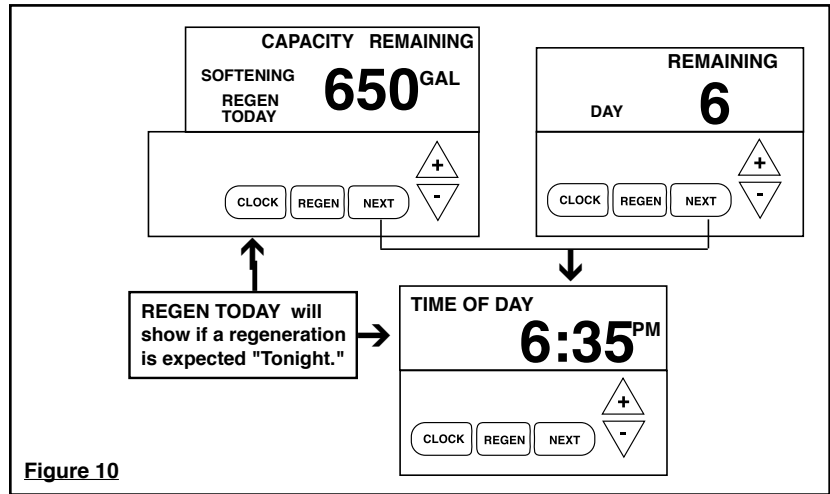

Figure 10

Regeneration Mode

Typically a system is set to regenerate at a time of low water usage. An example of a time with low water usage is when the household is asleep. If there is a demand for water when the system is regenerating, untreated water will be supplied.

When the system begins to regenerate, the display will change to include information about the step of the regeneration process and the time remaining for that step to be completed. The system runs through the steps automatically and will reset itself to provide treated water when the regeneration has been completed.

Regeneration Step #2
(shows time remaining in regen step is 8:22)

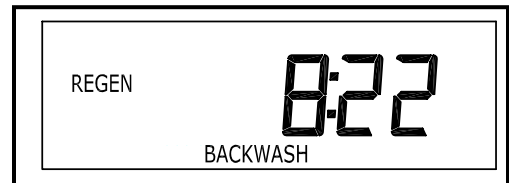

Figure 11

Manual Regeneration

Sometimes there is a need to regenerate the system, sooner than when the system calls for it, usually referred to as manual regeneration. There may be a period of heavy water usage because of guests or a heavy laundry day.

To initiate a manual regeneration at the preset delayed regeneration time, press and release "REGEN". The words "REGEN TODAY" will flash on the display to indicate that the system will regenerate at the preset delayed regeneration time. If you pressed the "REGEN" button in error, pressing the button again will cancel the request.

To initiate a manual regeneration immediately, press and hold the "REGEN" button for three seconds. The system will begin to regenerate immediately. The request cannot be cancelled. You must cycle all the way through the cycles to make it stop. PLEASE NOTE: This will reset the meter.

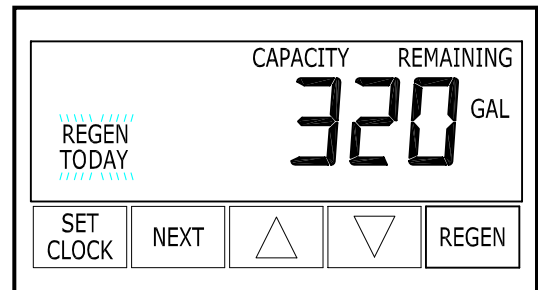

Figure 12

If back-to-back regenerations are desired, press and release "REGEN" button. "REGEN TODAY" will appear on screen. Push and hold REGEN button to initiate immediate regeneration. The softener will regenerate again at specified time. Back-to-back regenerations are recommended when salt is allowed to run out in brine tank.

Note: If the salt keeper does not contain salt, fill with salt and wait at least two hours before regenerating.

WATER SOFTENER DRAINING PROCEDURE

In cold weather climates it is common for plumbing systems that are not in use to be "winterized" or drained of all water to prevent any damage that may be caused by the excessive expansion of water when it freezes. To prevent damage to a water softener it must be **properly** drained also. A simple way to properly drain or winterize a water softener is to use compressed air to force all of the water out of the softener mineral tank. The following procedure will explain the process:

- 1) Initiate the softener into a manual regeneration cycle. After the refill cycle, advance control to backwash and allow it to complete the backwash cycle (this will clean the media) and start into the brine-draw cycle. Allow the regeneration to continue in the brine draw cycle until the brine is drawn out of the salt tank and the air check at the bottom of the brine pick-up tube shuts off. **NOTE: Be sure you have salt in the brine tank and allow 1 hour minimum to make a saturated brine. It is important that any liquid left in the softener tank when you finished blowing out system be saturated brine solution to prevent any damage to the softener.** At this time no more brine is introduced into the softener and the slow rinse process begins.
- 2) Turn the water supply inlet and outlet valves off to the water softener as soon as the air check shuts off and no more brine is being drawn into the softener (at the beginning of the slow rinse process).
- 3) Unplug the electric power leaving the softener control valve in the brine draw cycle.
- 4) Remove the brine refill elbow assembly from the control valve. Remove the refill flow control retainer assembly from the elbow. Reinstall the elbow assembly and secure with the locking clip. Disconnect the brine tube at the top of the salt keeper and force air into the brine tube toward the softener mineral tank and control valve. The air will force the brine/water solution that was drawn into the mineral tank out to drain through the control valve drain line. (An air compressor blow gun attachment with a portable air compressor works well.) Reinstall the brine line flow control retainer in side of the refill elbow assembly. Reinstall the brine refill elbow assembly and secure with locking clip.

CAUTION: You do not want to apply any more pressure than necessary to force the brine/water out of the mineral tank.

The small amount of brine/water that may be left in the

mineral tank will not expand enough to cause any damage to the softener when it freezes.

If your softener is equipped with an optional bottom drain on the mineral tank, you will have to follow all of the same procedures with the exception of the need for compressed air. With the brine tube disconnected from the salt keeper, raise it to a level above the softener control valve and temporarily secure it in this position. Now open the drain valve at the bottom of the mineral tank and allow all brine/water to drain from the mineral tank.

CAUTION: If a hose is connected to the drain valve to direct the brine/water to a floor drain be sure it runs downward and is unobstructed. When brine/water quits running at the drain, be sure to leave the drain valve open until you start the system up again.

- 5) At this time the salt keeper has very little water left in it. What liquid is left in the salt keeper is saturated brine, provided that there is still salt left in the tank. Saturated brine will not freeze solid and cause any damage and does not have to be drained any further from the brine tank.

If there is no salt left in the salt keeper when the system is drained we recommend dumping all of the water out of the brine tank at this time. See brine tank cleaning instructions. (#2 in Miscellaneous section, below)

- 6) **CAUTION:** It is important at this time to be assured that the inlet/outlet water supply piping is properly drained. Depending on how the water supply piping was routed to the water softener control valve, a water loop or trap may have been created.

Sometimes drain valve(s) are installed at the bottom of the loop to assure all water can be drained out. If not it may be necessary to disconnect the control valve from the piping system and open the inlet/outlet valve(s) to allow all the water to drain from the piping. This should be done after the rest of the plumbing system is drained.

- 7) Draining or winterizing of your softener is complete. Refer to the start-up procedures on page 6 when you are ready to start your softener.

MISCELLANEOUS

1. Salt Usage: See your water conditioning professional for a recommendation on the best type of salt for your application.
2. Salt Keeper Cleaning:
 - a. Remove brine tank cover.
 - b. Scoop out as much old salt as possible.
 - c. Disconnect brine tubing from safety brine valve at brine well.
 - d. Remove safety brine valve from brine well.
 - e. Place one hand in brine well to hold overflow nut and remove 2 piece overflow.
 - f. Remove optional brine well and grid plate, if used, from brine tank.
 - g. Remove any remaining salt and/or impurities from brine tank.
 - h. Using clean water and a brush or rag, wipe and rinse

inside of brine tank. Also wipe and rinse the grid plate and brine well.

- i. Reassemble brine tank reversing steps c - f. Note: If grid plate is used and it is damaged or cracked, replace with new one.
- j. Put brine tank in place making sure there is no debris or foreign material beneath it.
- k. Reconnect brine tubing to safety brine valve.
- l. Manually add 6 inches of water to the brine tank (or to approximately 1" above the grid plate, if used).
- m. Add new salt. Important: Do not add the old salt which was removed earlier unless it is clean and not mushy. We recommend using new salt.
- n. Follow the disinfection instructions found on page 6.
- o. Put on brine tank cover.

E³ SOFTENER SETUP QUICK REFERENCE

***Factory Settings are in Bold**

This is a reference setup procedure if programming changes are desired.

STEP 1S – Press NEXT and ▼ buttons simultaneously for 3 seconds. If screen in step 2S does not appear in 5 seconds the lock on the valve is activated.

STEP 2S – Choose Softening using ▼ or ▲ buttons. Press NEXT to go to Step 3S. Press REGEN to exit OEM Softener System Setup.

STEP 3S – Set Refill option using ▼ or ▲ buttons:

- “PoST” to refill the brine tank after the final rinse; or
- “PrE” to refill the brine tank two hours before the regeneration time set.

Press NEXT to go to Step 4S. Press REGEN to return to previous step.

Factory setting is PrE

STEP 4S – Program Code: Enter the desired program code from next page.

Prior to selecting a Program Code, verify the correct valve body, main piston, regenerant piston, and stack are being used, and that the injector or injector plug(s) are in the correct locations.

Factory setting is P14. Press NEXT to go to Step 5S. Press REGEN to return to previous step.

STEP 5S – Enter the ion exchange capacity in grains of hardness as calcium carbonate for the system based on test data using ▼ or ▲ buttons. Press NEXT to go to Step 6S. Press REGEN to return to previous step. See page 22 for factory settings.

STEP 6S – Enter the pounds of salt per regeneration using ▼ or ▲ buttons. Press NEXT to go to Step 7S. Press REGEN to return to previous step. See page 22 for factory settings.

STEP 7S – Set Gallons Capacity using ▼ or ▲ buttons:

- “AUTO” (reserve capacity automatically estimated and gallons capacity automatically calculated from grains capacity and water hardness);
- “oFF” (regeneration based on day override); or
- number of gallons (20 to 50,000).

Press NEXT to go to Step 8S. Press REGEN to return to previous step.

Factory setting is Auto.

STEP 8S – Set Regeneration Time Option using ▼ or ▲ buttons:

- “NORMAL” means regeneration will occur at the preset time;
- “on 0” means regeneration will occur immediately when the gallons capacity reaches 0 (zero); or
- “NORMAL + on 0” means regeneration will occur at one of the following:
 - the preset time when the gallons capacity falls below the reserve or the specified number of days between regenerations is reached whichever comes first; or
 - after 10 minutes of no water usage when the gallon capacity reaches 0 (zero).

Factory setting is normal, on 0. Press NEXT to exit Softener System Setup. Press REGEN to return to previous step. For further programming detail, see owner’s manual.

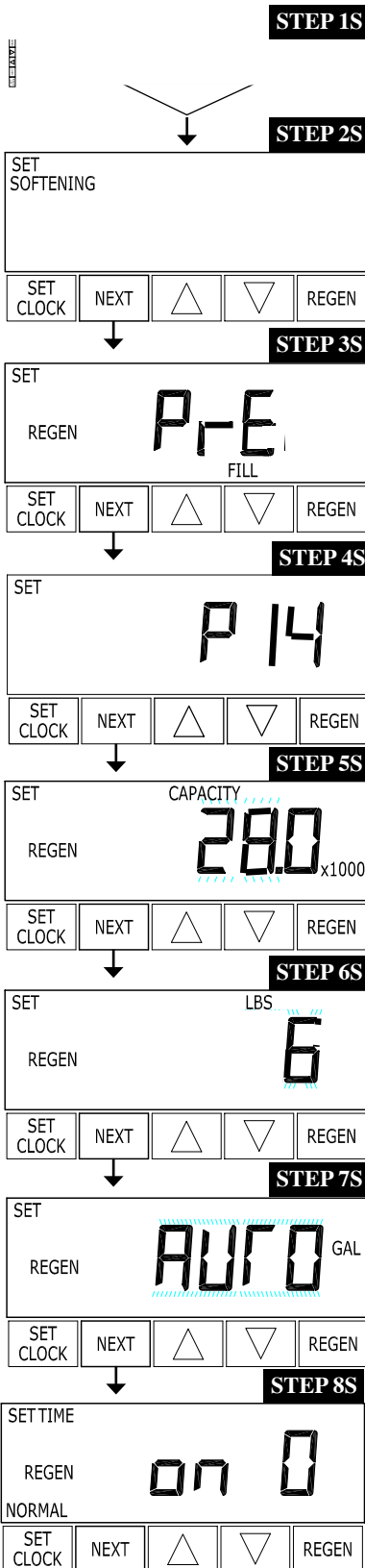

RETURN TO
NORMAL MODE

DOWNFLOW SOFTENER PROGRAM CODES

Program Code	Main Piston	1 st Backwash	Brine/Slow Rinse	2 nd Backwash	Fast Rinse
P1	Downflow	3	40	3	3
P2	Downflow	3	45	3	3
P3	Downflow	4	45	4	3
P4	Downflow	4	60	4	3
P5	Downflow	5	60	4	4
P6	Downflow	5	60	5	4
P7	Downflow	6	45	4	3
P8	Downflow	6	60	5	4
P9	Downflow	6	60	6	5
P10	Downflow	7	50	5	4
P11	Downflow	7	60	6	6
P12	Downflow	7	65	7	7
P13	Downflow	8	45	5	4
P14	Downflow	8	60	6	6
P15	Downflow	8	60	8	8
P16	Downflow	8	65	8	6
P17	Downflow	8	65	8	7
P18	Downflow	8	75	8	5
P19	Downflow	9	50	5	5
P20	Downflow	9	60	5	4
P21	Downflow	9	65	8	5
P22	Downflow	10	45	4	4
P23	Downflow	10	60	5	4
P24	Downflow	10	65	8	8
P25	Downflow	10	65	6	5
P26	Downflow	10	75	7	5
P27	Downflow	12	45	4	4
P28	Downflow	12	60	6	4
P29	Downflow	12	60	8	8
P30	Downflow	12	65	6	6
P31	Downflow	12	65	8	8
P32	Downflow	12	65	12	8
P33	Downflow	12	75	6	6
P34	Downflow	14	45	5	4
P35	Downflow	14	60	6	5
P36	Downflow	14	60	8	8
P37	Downflow	14	65	7	6
P38	Downflow	14	65	8	8
P39	Downflow	14	65	12	8
P40	Downflow	14	75	8	7
P41	Downflow	16	60	7	5
P42	Downflow	16	65	8	6
P43	Downflow	16	65	8	8
P44	Downflow	16	65	12	8
P45	Downflow	16	75	9	7
P50	Downflow	6	45	3	3
P51	Downflow	8	60	8	4
P52	Downflow	8	75	10	6

DIAGNOSTICS

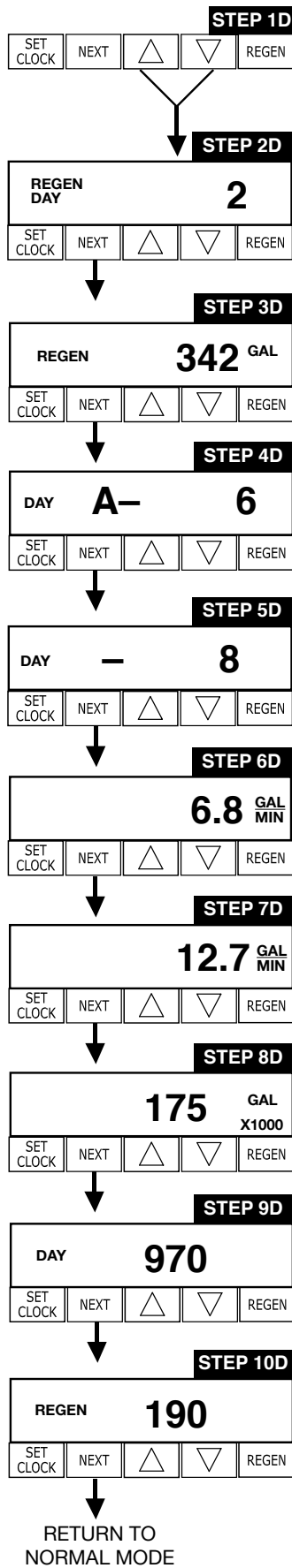

STEP 1D – Press ▼ or ▲ simultaneously for three seconds or until display changes.

STEP 2D – Days, since last regeneration: This display shows the days since the last regeneration occurred. Press the NEXT button to go to Step 3D. Press REGEN to exit Diagnostics.

STEP 3D – Gallons, since last regeneration: This display shows the number of gallons that have been treated since the last regeneration. This display will equal zero if a water meter is not installed. Press the NEXT button to go to Step 4D. Press REGEN to return to previous step.

STEP 4D – Gallons, reserve capacity used for last 7 days: If the valve is set up as a softener, a meter is installed and Set Gallons Capacity is set to "Auto," this display shows 0 day (for today) and flashes the reserve capacity. Pressing the ▲ button will show day 1 (which would be yesterday) and flashes the reserve capacity used. Pressing the ▲ button again will show day 2 (the day before yesterday) and the reserve capacity. Keep pressing the ▲ button to show the gallons for days 3, 4, 5 and 6. The ▼ button can be pressed to move backwards in the day series. Press the NEXT button at any time to go to Step 5D. Press REGEN to return to previous step.

STEP 5D – Gallons, 63 day usage history: This display shows day 1 (for yesterday) and flashes the number of gallons treated yesterday. Pressing the ▲ button will show day 2 (which would be the day before yesterday) and flashes the number of gallons treated on that day. Continue to press ▲ button to show the maximum number of gallons treated for the last 63 days. This display will show dashes if a water meter is not installed. Press the NEXT button at any time to go to Step 6D. Press REGEN to return to previous step.

STEP 6D – Flow rate, display flashes current flow rate. Turn the water on at one or more taps in the building. The flow rate in gallons per minute will be displayed. If flow stops the value will fall to zero in a few seconds. This display will equal zero if a water meter is not installed. Press the NEXT button to go to Step 7D. Press REGEN to return to previous step.

STEP 7D – Flow rate, maximum last seven days: Non-flashing display shows the maximum flow rate in gallons per minute that occurred in the last seven days. This display will equal zero if a water meter is not installed. Press the NEXT button to go to Step 8D. Press REGEN to return to previous step.

STEP 8D – Gallons, total used since last reset: The total number of gallons used since the last reset will be displayed. This display will equal zero if a water meter is not installed. Press the NEXT button to go to Step 9D. Press REGEN to return to previous step.

STEP 9D – Days, total number since last reset: The total number of days the control valve has been in service since last reset will be displayed. Press the NEXT button to go to Step 10D. Press REGEN to return to previous step.

STEP 10D – Regenerations, total number since last reset: The total number of regenerations that have occurred since last reset will be displayed. Press the NEXT button to exit Diagnostics. Press REGEN to return to previous step.

When desired, all information in Diagnostics may be reset to zero when the valve is installed in a new location. To reset to zero, press NEXT and ▼ buttons simultaneously to go to the Service screen, and release. Press ▼ or ▲ simultaneously to reset diagnostic valves to zero. Screen will return to user display.

VALVE HISTORY



STEP 1VH – Press ▼ and ▲ simultaneously for three seconds and release. The press ▼ and ▲ simultaneously and release. If screen in 2VH does not appear in 5 seconds the lock on the valve is activated. To unlock press ▼, NEXT, ▲, and SET CLOCK in sequence, then press ▼ and ▲ simultaneously for 3 seconds and release. Then press ▼ and ▲ simultaneously and release.

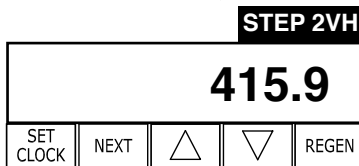

STEP 2VH – Software Version: This display shows the software version of the valve. Press the NEXT button to go to Step 3VH. Press REGEN to exit Valve History.

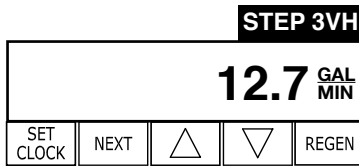

STEP 3VH* – Flow rate, maximum since startup: This display shows the maximum flow rate in gallons per minute that occurred since startup. This display will equal zero if a water meter is not installed. Press the NEXT button to go to Step 4VH. Press REGEN to return to previous step.

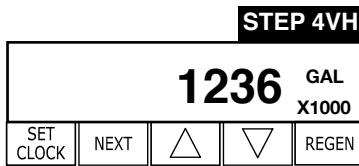

STEP 4VH – Gallons, total used since start-up: This display shows the total gallons treated since startup. This display will equal zero if a water meter is not installed. Press the NEXT button to go to Step 5VH. Press REGEN to return to previous step.

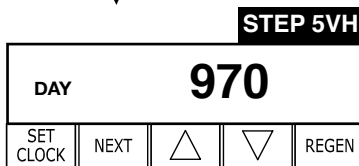

STEP 5VH – Days, total since start-up: This display shows the total days since startup. Press the NEXT button to go to Step 6VH. Press REGEN to return to previous step.

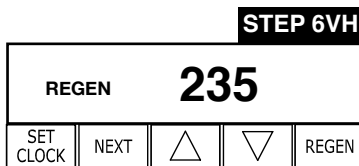

STEP 6VH – Regenerations, total number since start-up: This display shows the total number of regenerations that have occurred since startup. Press the NEXT button to go to Step 7VH. Press REGEN to return to previous step.

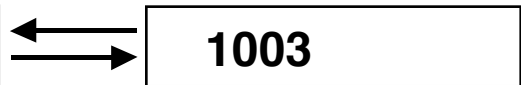
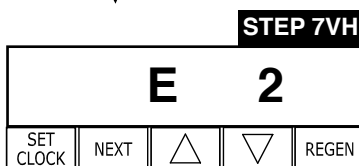

STEP 7VH – Error Log: This display shows a history of the last 10 errors generated by the control during operation. Press the ▼ or ▲ buttons to review each error recorded. Press the NEXT button to exit Valve History. Press REGEN to return to previous step.

RETURN TO
NORMAL MODE

*Valves in Step 3VH through Step 7VH cannot be reset.

TROUBLE SHOOTING

PROBLEM	CAUSE	CORRECTION
1.ERROR followed by code number		
Error Code 1001 - Unable to recognize start of regeneration	A. Control valve has just been serviced	A. Press NEXT and REGEN for 3 seconds or unplug power source jack from PC Board (black wire) and plug back in to reset control valve
Error Code 1002 - Unexpected stall	B. Foreign matter is lodged in control valve	B. Check piston and spacer stack assembly for foreign matter
Error Code 1003 - Motor ran to long, timed out trying to reach next cycle position	C. High drive forces on piston	C. Address high drive forces by Loosening drive cap assembly 1/4 turn
Error Code 1004 - Motor ran to long, timed out trying to reach home position	D1. Control valve piston not in home position	D1. Press NEXT and REGEN for 3 seconds or unplug power source jack (black wire) and plug back in to reset control valve
	D2. Motor not inserted fully to engage pinion, motor wires broken or disconnected, motor failure	D2. Check motor and wiring. Replace motor if necessary
	D3. Drive gear label dirty or damaged, missing or broken gear	D3. Replace or clean drive gear
If other Error Codes display contact the factory	D4. Drive bracket incorrectly aligned to back plate	D4. Reset drive bracket
	D5. PC board is damaged or defective	D5. Replace PC board
	D6. PC board incorrectly aligned to drive bracket	D6. Ensure PC board is correctly snapped on to drive bracket
2. Control valve stalled in regeneration	A. Motor not operating	A. Replace Motor
	B. No electric power at outlet	B. Repair outlet our use working outlet
	C. Defective transformer	C. Replace transformer
	D. Defective PC board	D. Replace PC board
	E. Broken drive gear or drive cap assembly	E. Replace drive gear or drive cap assembly
	F. Broken piston retainer	F. Replace drive cap assembly
	G. Broken main or regenerant piston	G. Replace main or regenerant piston
3. Control valve does not regenerate automatically when REGEN button is depressed and held	A. Transformer unplugged	A. Connect transformer
	B. No electric power at outlet	B. Repair outlet or use working outlet
	C. Broken drive gear or drive cap assembly	C. Replace drive gear or drive cap assembly
	D. Defective PC board	D. Replace PC board
4. Control valve does not regenerate automatically but does when REGEN button is depressed	A. By-pass valve in bypass position	A. Put control valve in service position
	B. Meter connection disconnected	B. Connect meter to PC board
	C. Restricted/stalled meter turbine	C. Remove meter and check for rotation or foreign matter
	D. Defective meter	D. Replace meter
	E. Defective PC board	E. Replace PC board
	F. Set-up error	F. Check control valve set-up procedure
5. Time of day flashes on and off	A. Battery back-up maintains time of day up to 8 hours in event of power outage and battery is not depleted. If time of day is flashing, it indicates battery is depleted.	A. Reset time of day and replace battery on PC Board (Lithium coin type battery 2032)
	B. Prior to 2/2007 PC Board did not have battery back-up - capacitor held time of day up to 2 hours.	B. Reset time of day.
6. Softener delivers hard water.	A. Bypass valve is open or faulty.	A. Close bypass valve or replace.
	B. No salt or low salt level in brine tank.	B. Add salt to brine tank and maintain salt level above water level.
	C. Softener fails to draw brine.	C. See problem #11.
	D. Excessive water usage.	D. Check gallon capacity settings.
	E. Insufficient brine level in brine tank.	E. Check brine refill setting and refill flow restrictor for blockage.
	F. Resin level inadequate.	F. See problem #8.
	G. Meter faulty.	G. Test meter and clean or replace meter.
	H. Raw water hardness fluctuation.	H. Test raw water hardness and adjust settings to highest known hardness.
7. Unit uses too much salt.	A. Improper brine refill setting.	A. Check brine refill setting for proper salt dosage
	B. Improper settings.	B. Check water hardness and reevaluate capacity setting specification
	C. Excessive water in brine tank.	C. See problem #10.
	D. Leaking faucets, toilets, etc...	D. Repair or replace those items.

TROUBLE SHOOTING

PROBLEM	CAUSE	CORRECTION
8. Loss of resin.	<ul style="list-style-type: none"> A. Backwash controller missing. B. Faulty distributor tube assembly. C. Air in water supply system. 	<ul style="list-style-type: none"> A. Install backwash controller. B. Check distributor tube assembly for cracks or holes. C. <ul style="list-style-type: none"> 1. Check for leaks in brine lines, fittings, or air check. Repair or replace. 2. Install upper distributor. 3. Ensure that water supply system has an air eliminator.
9. Softener delivers salt water.	<ul style="list-style-type: none"> A. Low water pressure. B. Excessive water in brine tank. C. Wrong size injector. 	<ul style="list-style-type: none"> A. Check incoming water pressure - Must remain at minimum of 25 psi. B. See problem #10. C. Install correct injector.
10. Excessive water in brine tank.	<ul style="list-style-type: none"> A. Plugged injector. B. Faulty piston assembly. C. Plugged or kinked drain line. D. Backwash flow controller closed off. E. Defective brine line flow control. 	<ul style="list-style-type: none"> A. Remove injector and clean ports. B. Replace piston assembly. C. Inspect drain line for kinks or plugging. D. Check backwash flow controller. E. Replace brine refill flow control.
11. Softener fails to draw brine.	<ul style="list-style-type: none"> A. Injector is plugged. B. Faulty piston assembly. C. Brine line connection leak. D. Drain line plugged creating excess back pressure. E. Drain line too long or too high F. Low inlet pressure. 	<ul style="list-style-type: none"> A. Remove injector and clean ports. B. Check piston assembly. C. Inspect brine line during refill cycle for leaks. D. Inspect drain line for blockage. E. Refer to drain line specifications. F. Increase inlet pressure to a minimum of 25 psi.
12. Continuous flow to drain.	<ul style="list-style-type: none"> A. Piston assembly failure. B. Motor failure. C. Circuit board failure. 	<ul style="list-style-type: none"> A. Replace piston assembly. B. Replace motor. C. Replace circuit board.
13. Loss of water pressure.	<ul style="list-style-type: none"> A. Iron build-up in resin. B. Resin bed fouled with sand or sediment. C. Resin bed mushing due to high amount of oxidizers in water supply (chlorine). 	<ul style="list-style-type: none"> A. See problem #14. B. Rebed softener and install sediment filter ahead of softener. C. Rebed softener. Install dechlorinator system
14. Iron in softened water.	<ul style="list-style-type: none"> A. Iron has fouled resin bed. B. Iron is not in a soluble state. C. Prefilter failure. D. Iron level excessive. E. Control fails to regenerate. 	<ul style="list-style-type: none"> A. Use iron reducing resin cleaner to cleanse resin bed, and increase salt dosage or regenerate more frequently. Install an Iron Curtain System ahead of the softener. B. Test water to determine type of iron, install iron reduction system. C. Check prefilter. D. Install iron reduction system. E. See problem #4.
15. Absent or incomplete LED display	<ul style="list-style-type: none"> A. Transformer unplugged B. No electric power at outlet C. Defective transformer D. Short in meter E. Defective PC board 	<ul style="list-style-type: none"> A. Plug transformer into uninterrupted outlet B. Repair outlet or use working outlet C. Replace transformer D. Unplug meter from PC board, if LED display lights appropriately, replace meter E. Replace PC board
16. Control does not display correct time of day	<ul style="list-style-type: none"> A. Power outage > 8 hours B. Power outage < 8 hours, time of day flashing, battery depleted 	<ul style="list-style-type: none"> A. Reset time of day B. Replace lithium coin type battery on circuit board Model 2032 battery
17. No "softening" or "filtering" display when water is flowing	<ul style="list-style-type: none"> A. Bypass valve in bypass position B. Meter connection disconnected C. Restricted/stalled meter turbine D. Defective meter E. Defective PC board 	<ul style="list-style-type: none"> A. Put bypass valve in service position B. Connect meter to PC board C. Remove meter and check for rotation, clean foreign material D. Replace meter E. Replace PC board
18. Control valve regenerates at wrong time of day	<ul style="list-style-type: none"> A. Power outages > 8 hours B. Time of day not set correctly C. Time of regeneration incorrect D. Control valve set at "on 0" (immediate regeneration) E. Control valve set at NORMAL + on 0 	<ul style="list-style-type: none"> A. Reset control valve to correct time of day, replace battery if time of day flashing B. Reset to correct time of day C. Reset regeneration time D. Check control valve set-up procedure regeneration time option (see table 6, page 19) E. Check control valve set-up procedure regeneration time option (see table 6, page 19)

E³ SERIES CONDITIONER & BRINE TANK ASSEMBLIES

Item	Description	Qty	Part #	
1	Control Center-Metered	1	109370	Specify Size (see pages 13-17 for detailed components)
2	Top Diffuser	1	101539	
3&4	Mineral Tank Assembly			<u>Item 3 only</u> <u>Item 4 only</u>
			Mineral Tank	Distributor Assy
	E ³ -024 8 x 44	1	109290	101505
	E ³ -032 9 x 48	1	109291	101508
	E ³ -032 10 x 44	1	109292	101505
	E ³ -048 10 x 54	1	109293	101512
	E ³ -064 12 x 52	1	109846	101510
5	Ion Exchange Resin	*	101108	*See Specifications for amount
6	Underbedding	*	100983	*See Specifications for amount
7-13a	Brine Tank Assy (18x33)-Blue	1	104517	
b	Brine Tank Assy (18x40)-Blue	1	104414	
7	3/8" x 6" Brine Line	1	102671	
8 a	Brine Tank Assy (18x33) No Grid-Black	1	104409	
b	Brine Tank Assy (18x40) No Grid-Black	1	104415	
9a,b	Brine Tank Cover 18"	1	Included with 8a,b	
c	Brine Tank Cover 24"	1	Included with 8c,d	
10-14a	Safety Brine Valve Assy 33"	1	101302	
10 b,c	Safety Brine Valve Assy 41"	1	101305	
10	Cap, Brine Well	2	101365	
11*	Safety Brine Valve	1	101274	
12	Float Assembly	1	101660	
13	Air Check	1	101181	
14 a	Brine Well 33"	1	102876	
b,c	Brine Well 40"-41"	1	102877	
15	2-Piece Overflow	1	102217	
-	Owners Manual	1	109317	

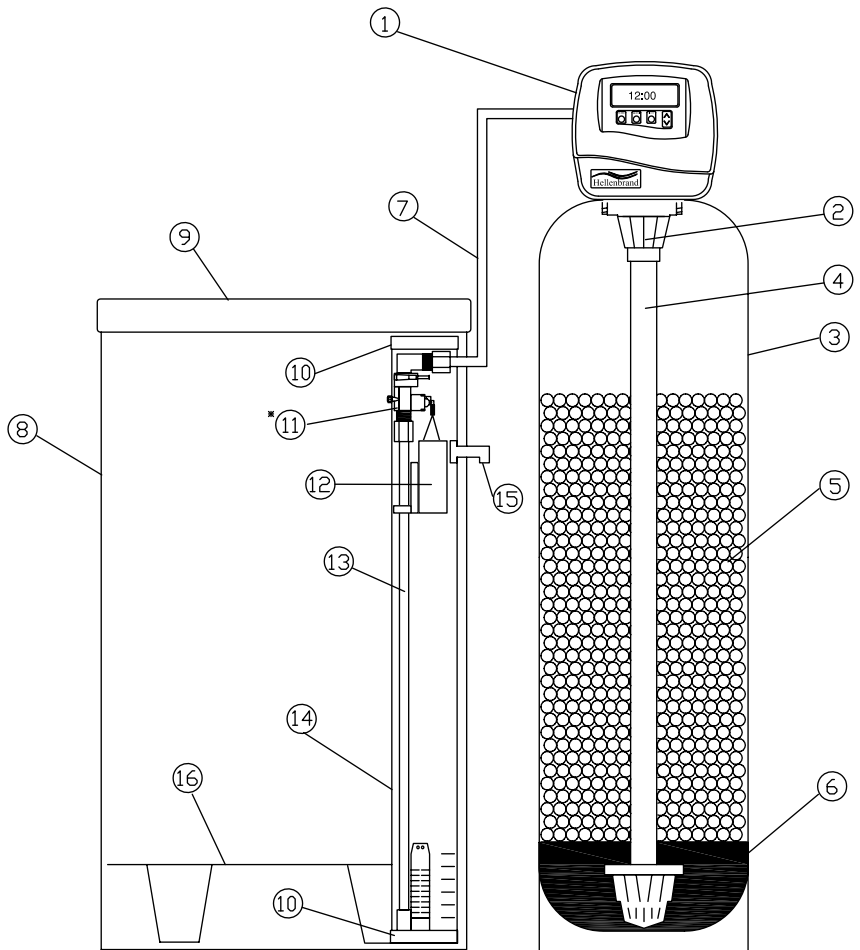
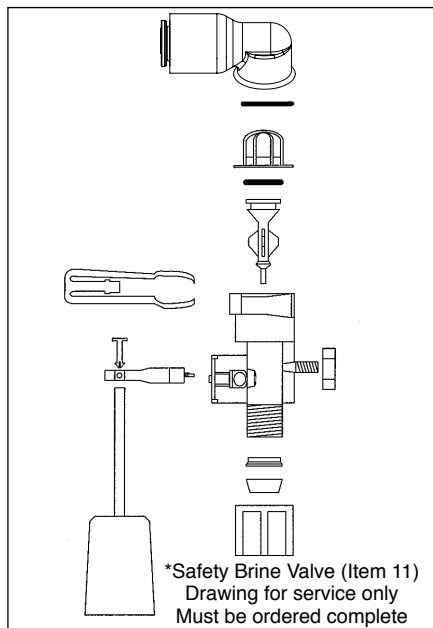

FRONT COVER AND DRIVE ASSEMBLY

ITEM NO.	ORDER NO.	DESCRIPTION	QTY.
1	109380	Black Cover Assy w/E ³ Label	1
2-6	101610	Drive Assy.	*
2	102096	Motor	1
3	101262	Drive Bracket & Spring Clip	1
4	109379	PC Board	1
5	101746	Drive Gear 12x36	3
6	101459	Drive Gear Cover	1
Not Shown	102653	Transformer 110V-12V	1

After completing any valve maintenance involving the drive assembly or the drive cap assembly and pistons, press and hold NEXT and REGEN buttons for 3 seconds or unplug power source jack from the printed circuit board (black wire) and plug back in. This resets the electronics and establishes the service piston position. The display should flash all wording, then flash the software version (ex: 154) and then reset the valve to the service position.

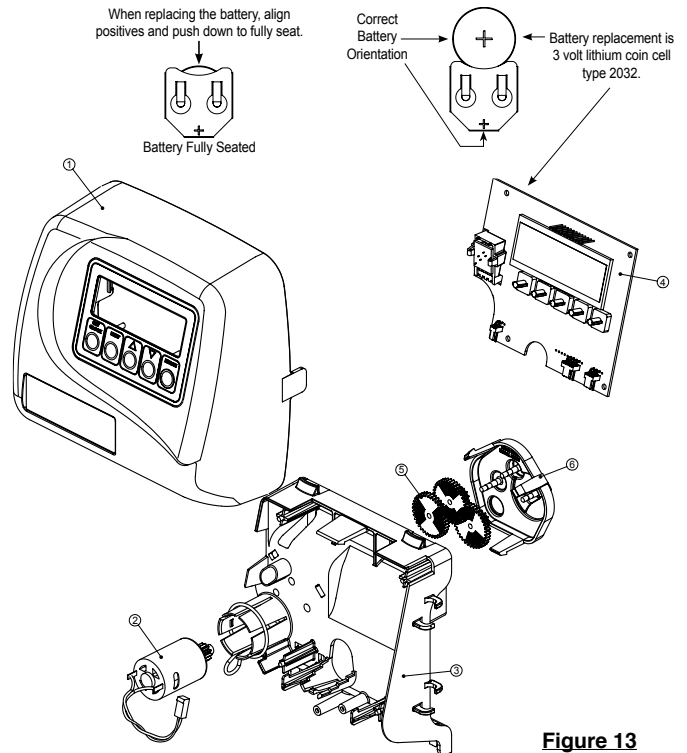

Figure 13

DRIVE CAP ASSEMBLY, DOWNFLOW PISTON, REGENERANT PISTON AND SPACER STACK ASSEMBLY

ITEM NO.	ORDER NO.	DESCRIPTION	QTY.
1	102548	Spacer Stack Assy	1
2	101613	Drive Cap Assy.	1
3	102167	O-Ring 228	1
4a	102292	Piston Downflow Assy.	1**
4b	102297	Piston Upflow Assy.	1
5	102296	Regenerant Piston	1
6	102192	O-ring 337-tank	1
7	102165	O-ring distributor tube	1
Not Shown	102892	Service Wrench	1

*102292 is labeled with DN and 102297 is labeled with UP.
 Note: The regenerant piston is not used in backwash only applications.
 **Standard Option.

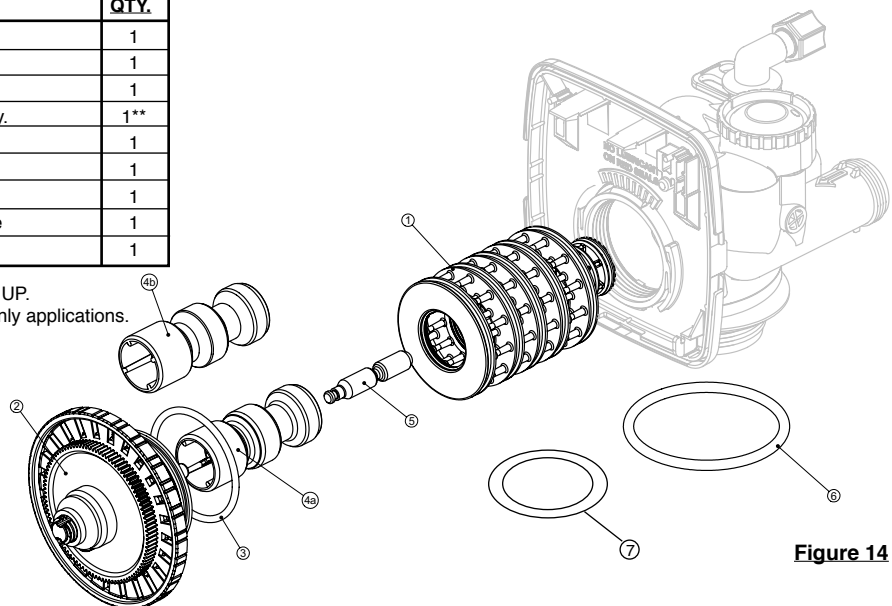

Figure 14

Do not use vaseline, oils, other hydrocarbon lubricants or spray silicone anywhere. A silicon lubricant may be used on black o-rings but is not necessary. **Avoid any type of lubricants, including silicone, on red or clear lip seals.**

After completing any valve maintenance involving the drive assembly or the drive cap assembly and pistons, press and hold NEXT and REGEN buttons for 3 seconds or unplug power source jack from the printed circuit board (black wire) and plug back in. This resets the electronics and establishes the service piston position. The display should flash all wording, then flash the software version (ex: 154) and then reset the valve to the service position.

INJECTOR CAP, INJECTOR SCREEN, INJECTOR, PLUG AND O-RING

ITEM NO.	ORDER NO.	DESCRIPTION	QTY.
1	101375	Injector Cap	1
2	102159	O-ring 135	1
3	102457	Injector Screen	1
4	102319	Injector Assy. Z Plug-Filter	1
5	101825	Injector Assy. A Black	1
	101826	Injector Assy. B Brown	
	101827	Injector Assy. C Violet	
	101828	Injector Assy. D Red	
	101829	Injector Assy. E White	
	101830	Injector Assy. F Blue	
	101831	Injector Assy. G Yellow	
	101832	Injector Assy. H Green	
	101833	Injector Assy. I Orange	
	101834	Injector Assy. J Light Blue	
	101835	Injector Assy. K Light Green	
Not Shown	106767	O-ring 011	*
Not Shown	106768	O-ring 013	*

* The injector plug and the injector each contain one 011 (lower) and 013 (upper) o-ring.

See system specification, injector color on page 18 for current injector.

Note: For upflow position, injector is located in the up hole and injector plug in the down hole. For a filter that only backwashes injector plugs are located in both holes.

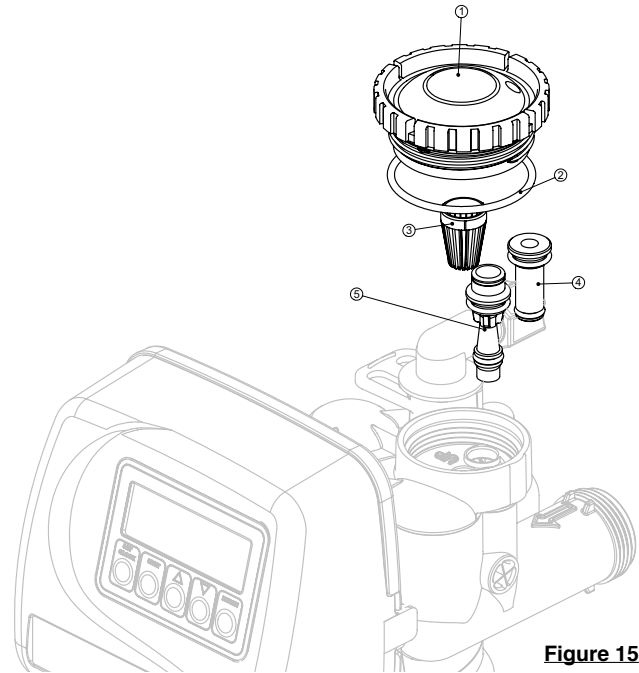
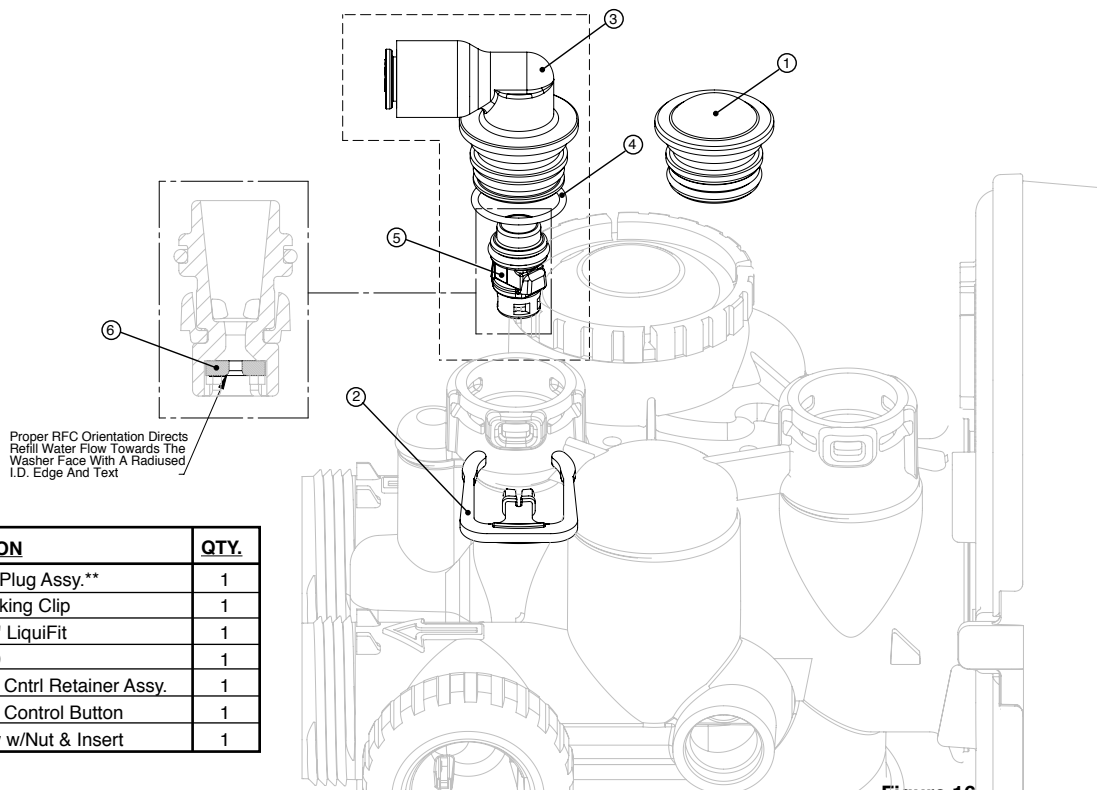

Figure 15

The nuts and caps are designed to be unscrewed or tightened by hand or with the special plastic wrench. If necessary a pliers can be used to unscrew the nut or cap. Do not use a pipe wrench to tighten or loosen nuts or caps. Do not place screwdriver in slots on caps and/or tap with a hammer.

Do not use pipe dope or other sealants on threads. Teflon tape must be used on threads of the 1" NPT connection and on the threads for the drain line connection. Teflon tape is not necessary on the nut connection nor caps because of o-rings seals.

REFILL AND REFILL PORT PLUG



ITEM NO.	ORDER NO.	DESCRIPTION	QTY.
1	102322	Refill Port Plug Assy.**	1
2	101414	Elbow Locking Clip	1
3	111389	Elbow 3/8" LiquiFit	1
4	102153	O-ring 019	1
5	102418*	Refill Flow Cntrl Retainer Assy.	1
6	102421	Refill Flow Control Button	1
Not Shown	101617	1/2" Elbow w/Nut & Insert	1

* Assembly includes item #6.

**This part is required for backwash only systems.

Figure 16

DRAIN LINE - 3/4"

ITEM NO.	ORDER NO.	DESCRIPTION	QTY.
1	101414	Elbow Locking Clip	1
2	101871	Polytube Insert, 5/8"	Optional
3	102131	Nut, 3/4" Drain Elbow	Optional
4-5	101618	Drain Elbow 3/4" Male Assy-Vent	Optional
4-5	101619	Drain Elbow 3/4" Male Assy-No Vent	1
5	102153	O-ring 019	1
6	102406	DLFC Retainer Assy.	1
7	101551	DLFC 0.7 gpm for 3/4"	One DLFC must be used if 3/4 fitting is used
	101552	DLFC 1.0 gpm for 3/4"	
	101556	DLFC 1.3 gpm for 3/4"	
	101559	DLFC 1.7 gpm for 3/4"	
	101574	DLFC 2.2 gpm for 3/4"	
	101577	DLFC 2.7 gpm for 3/4"	
	101583	DLFC 3.2 gpm for 3/4"	
	101588	DLFC 4.2 gpm for 3/4"	
	101591	DLFC 5.3 gpm for 3/4"	
	101593	DLFC 6.5 gpm for 3/4"	
	101595	DLFC 7.5 gpm for 3/4"	
	101598	DLFC 9.0 gpm for 3/4"	
	101561	DLFC 10.0 gpm for 3/4"	

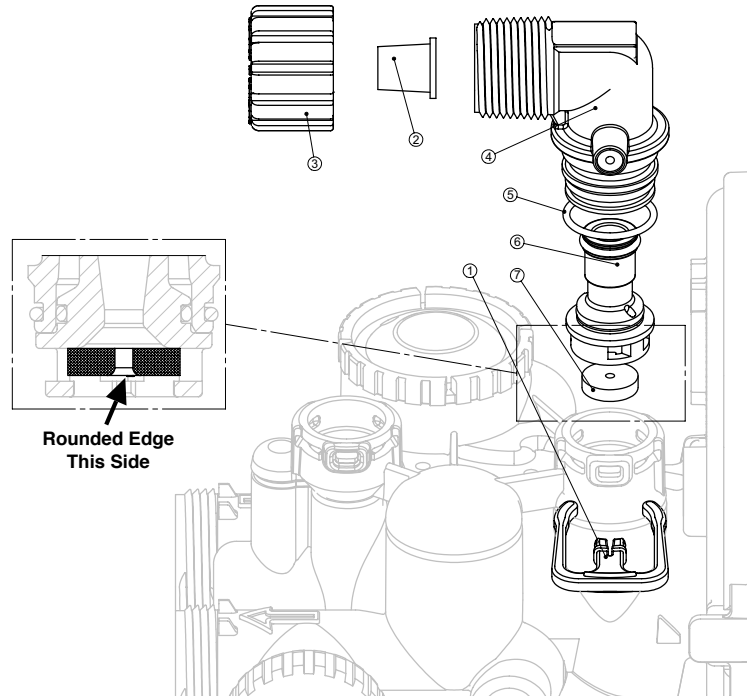

Figure 17

Systems are shipped without 3/4" nut for drain elbow (polytube installation only) and 5/8" polytube insert (polytube installation only).

See System Specifications DLFC on page 18, for correct DLFC size for your unit.

DRAIN LINE - 1"

ITEM NO.	ORDER NO.	DESCRIPTION	QTY.
1	101414	Elbow Locking Clip	1
2-8	101636	Drain Ftg, 1" Straight Asy-No Vent	1
3*	101244	Drain Ftg Body, 1"	1
4*	101160	Drain Ftg Adapter, 1"	1
5*	102153	O-ring 019	1
6*	102437	Split Ring	1
7*	102141	Nut, 1" QC	1
8*	102165	O-ring 215	1
9	101599	DLFC 9.0 gpm for 1"	One DLFC must be used if 1" fitting is used
	101562	DLFC 10.0 gpm for 1"	
	101564	DLFC 11.0 gpm for 1"	
	101567	DLFC 13.0 gpm for 1"	
	101568	DLFC 15.0 gpm for 1"	
	101571	DLFC 17.0 gpm for 1"	
	101578	DLFC 20.0 gpm for 1"	
	101580	DLFC 25.0 gpm for 1"	

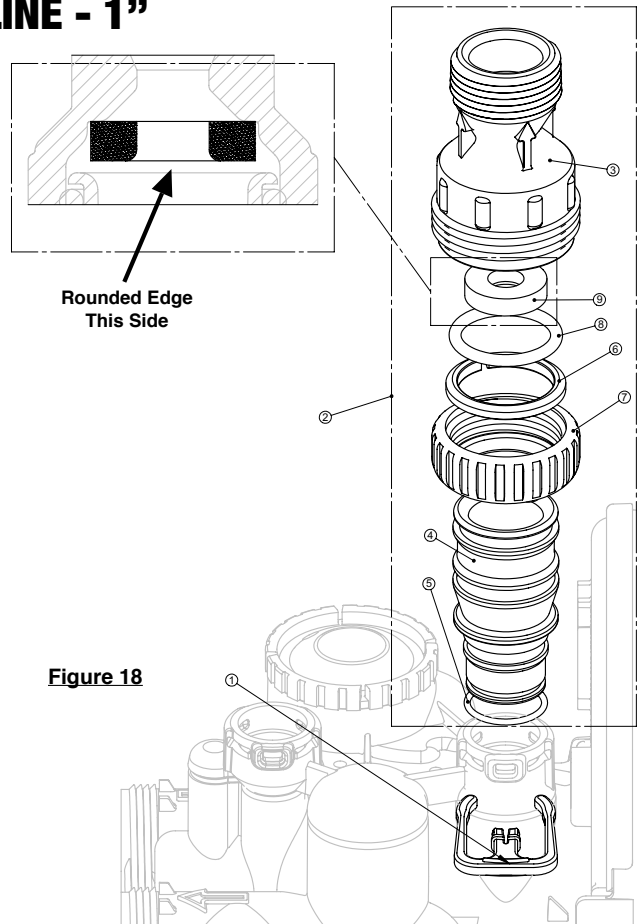

Figure 18

See System Specifications DLFC on page 18, for correct DLFC size for your unit.

The nuts and caps are designed to be unscrewed or tightened by hand or with the special plastic wrench. If necessary a pliers can be used to unscrew the nut or cap. Do not use a pipe wrench to tighten or loosen nuts or caps. Do not place screwdriver in slots on caps and/or tap with a hammer.

Do not use pipe dope or other sealants on threads. Teflon tape must be used on threads of the 1" NPT connection and on the threads for the drain line connection. Teflon tape is not necessary on the nut connection nor caps because of o-rings seals.

WATER METER AND METER PLUG

ITEM NO.	ORDER NO.	DESCRIPTION	QTY.
1	102141	Nut 1" QC	1
2-4	102051*	Meter Assy.	1
3	102687	Turbine Assy.	1
4	102165	O-ring 215	1
5	102321	Meter Plug Assy.**	1

*Order number 102051 includes 102687 and 102165, which are item numbers 3 & 4.

**Only used if metering is not to be done (time clock units)

The nuts and caps are designed to be unscrewed or tightened by hand or with the special plastic wrench. If necessary a pliers can be used to unscrew the nut or cap. Do not use a pipe wrench to tighten or loosen nuts or caps. Do not place screwdriver in slots on caps and/or tap with a hammer.

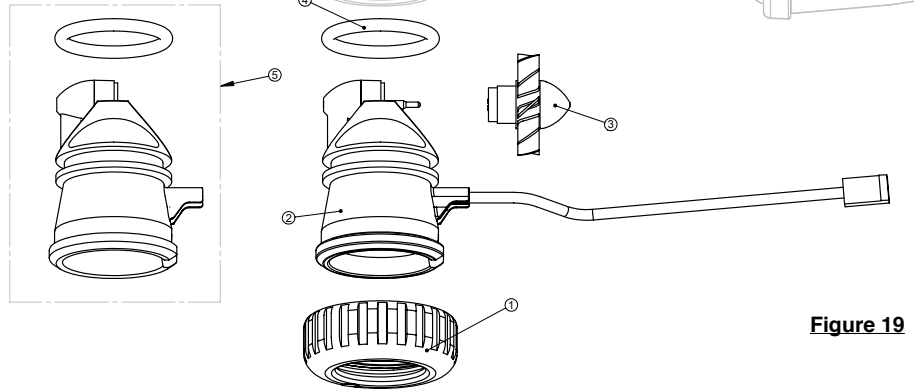

Figure 19

BYPASS VALVE

Bypass Valve

ITEM NO.	ORDER NO.	DESCRIPTION	QTY
1	102141	Nut 1" Quick Connect	2
2	102437	Split Ring	2
3	102165	O'Ring 215	2
4	102450	Bypass 1" Rotor	2
5	110997	Bypass Cap	2
6	110998	Bypass Handle	2
7	109479	Bypass Rotor Seal Retainer	2
8	102159	O-Ring 135	2
9	102161	O-Ring 112	2
10	102160	O-Ring 214	2

(Not Shown) Bypass Vertical Adapter Assembly

ORDER NO.	DESCRIPTION	QTY
102141	Nut 1" Quick Connect	2
102437	Split Ring	2
102165	O'Ring 215	2
106858	Bypass Vertical Adapter	2

The nuts and caps are designed to be unscrewed or tightened by hand or with the special plastic wrench. If necessary a pliers can be used to unscrew the nut or cap. Do not use a pipe wrench to tighten or loosen nuts or caps. Do not place screwdriver in slots on caps and/or tap with a hammer.

Do not use pipe dope or other sealants on threads. Teflon tape must be used on threads of the 1" NPT connection and on the threads for the drain line connection. Teflon tape is not necessary on the nut connection nor caps because of o-ring seals.

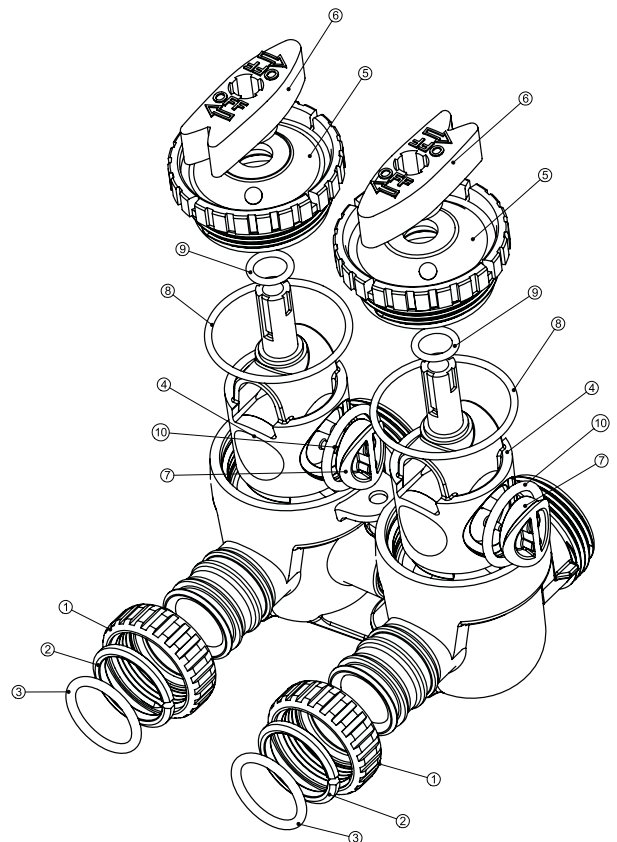
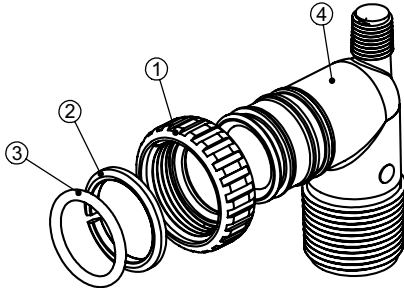

Figure 20

INSTALLATION FITTING ASSEMBLIES

ITEM NO.	ORDER NO.	DESCRIPTION	QTY.
1	102141	Nut, 1" Quick Connect	2
2	102437	Split Ring	2
3	102165	O-Ring 215	2
4	106761	Fitting, 1" PVC Male NPT Elb.	2
1-4	101639	Fitting, 1" PVC Male NPT Asy.	1

Figure 21



ITEM NO.	ORDER NO.	DESCRIPTION	QTY.
1	102141	Nut, 1" Quick Connect	2
2	102437	Split Ring	2
3	102165	O-Ring 215	2
4	106762	Fitting, 3/4" & 1" PVC Solv. 90	2
1-4	101640	Fitting, 3/4" & 1" PVC Solv 90	1

Figure 22

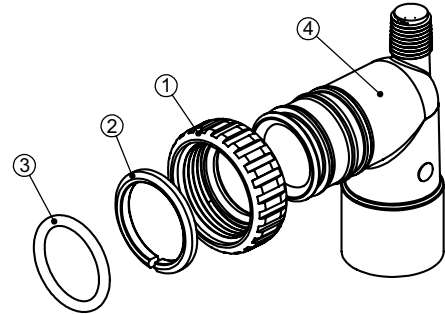

The nuts and caps are designed to be unscrewed or tightened by hand or with the special plastic wrench. If necessary a pliers can be used to unscrew the nut or cap. Do not use a pipe wrench to tighten or loosen nuts or caps. Do not place screwdriver in slots on caps and/or tap with a hammer.

Do not use pipe dope or other sealants on threads. Teflon tape must be used on threads of the 1" NPT connection and on the threads for the drain line connection. Teflon tape is not necessary on the nut connection nor caps because of o-rings seals.

ITEM NO.	ORDER NO.	DESCRIPTION	QTY.
1	102141	Nut 1" Quick Connect	2
2	102437	Split Ring	2
3	102165	O-Ring 215	2
4	106763	Fitting 1" Brass Sweat	2
1-4	108618	Fitting 1" Lead Free Brass Sweat Asy (Set of 2)	1

Figure 23

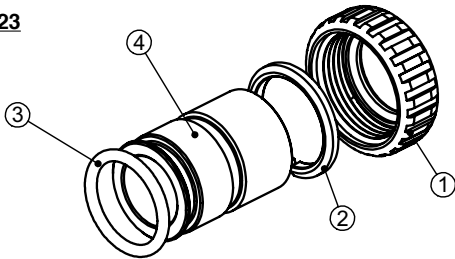

ITEM NO.	ORDER NO.	DESCRIPTION	QTY.
1	102141	Nut 1" Quick Connect	2
2	102437	Split Ring	2
3	102165	O-Ring 215	2
4	106764	Fitting 1" Brass Sweat	2
1-4	108617	Fitting 1" Lead Free Brass Sweat Asy (Set of 2)	1

Figure 24

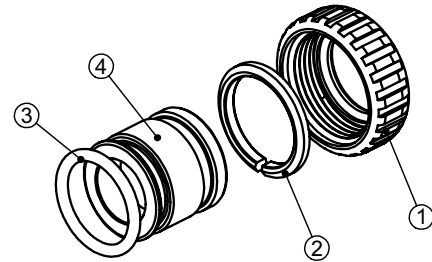

ITEM NO.	ORDER NO.	DESCRIPTION	QTY.
1	102141	Nut 1" Quick Connect	2
2	102437	Split Ring	2
3	102165	O-Ring 215	2
4	110135	Fitting 3/4" Brass SharkBite	2

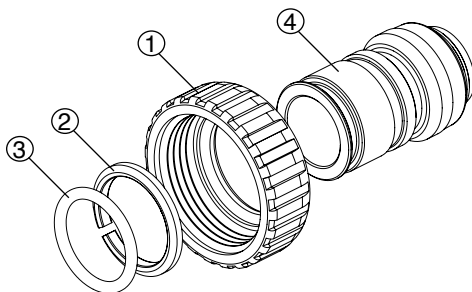

ITEM NO.	ORDER NO.	DESCRIPTION	QTY.
1	102141	Nut 1" Quick Connect	2
2	102437	Split Ring	2
3	102165	O-Ring 215	2
4	110136	Fitting 1" Brass SharkBite	2

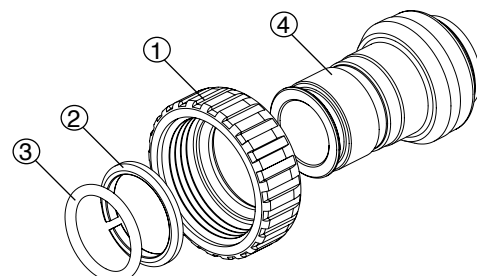

E³ SERIES SYSTEM SPECIFICATIONS

E3Specifications - Downflow

High Backwash Models

MODEL	E3-024	E3-032	E3-032-10	E3-048	E3-064	E3-024-948	E3-032-1054	E3-048-1354	E3-064-1465
FACTORY PRESET MINUTES									
FILL: MINUTES	3.0	4.0	4.0	6.0	8.0	7.5	10.0	15.0	20.0
GALLONS	1.5	2.0	2.0	3.0	4.0	3.8	5.0	7.5	10.0
BACKWASH: MINUTES	8.0	8.0	8.0	8.0	8.0	8.0	8.0	8.0	8.0
GALLONS	10.4	13.6	17.6	17.6	33.6	25.6	33.6	52.0	60.0
BRINE: MINUTES	60.0	60.0	60.0	60.0	68.0	60.0	60.0	60.0	60.0
GALLONS	14.4	16.2	16.2	19.2	38.1	14.1	16.2	19.2	33.6
SECOND BACKWASH MINUTES	6.0	6.0	6.0	6.0	6.0	6.0	6.0	6.0	6.0
GALLONS	7.8	10.2	13.2	13.2	19.2	19.2	25.2	39.0	45.0
RINSE: MINUTES	6.0	6.0	6.0	6.0	6.0	6.0	6.0	6.0	6.0
GALLONS	7.8	10.2	13.2	13.2	19.2	19.2	25.2	39.0	45.0
TOTAL REGENERATION IN GALLONS @35 PSI, INCLUDES BRINE MAKE UP.									
	41.9	52.2	62.2	66.2	114.1	81.9	105.2	156.7	193.6
Refill - Pounds of Salt									
HIGH EFFICIENCY SALTING	2.5	3.3	3.3	4.95	6.6				
LOW SALTING	4.5	6	6	9	12	5	6	9	12
MEDIUM SALTING	7.5	10	10	15	20	7.5	10.0	15.0	20.0
HIGH SALTING	11.5	15	15	22.5	30	11.5	15.0	22.5	30.0
Capacity - Grains									
HIGH EFFICIENCY SALTING	10,492	13,972	13,972	20,958	27,944				
LOW SALTING	17,200	22,930	22,930	34,400	45,870	17,200	22,930	34,400	45,870
MEDIUM SALTING	21,040	28,060	28,060	42,090	56,120	21,040	28,060	42,090	56,120
HIGH SALTING	24,230	32,310	32,310	48,460	64,620	24,230	32,310	48,460	64,620
Salt efficiency at factory settings (grains of hardness reduced per lb. of salt)	3822	3822	3822	3822	3822	2144	2154	2154	2154
SERVICE FLOW RATE									
FLOW RATE AT 10 PSI	9.8	10.1	11.3	10.5	14.2	9.8	11.3	10.5	14.2
FLOW RATE AT 15 PSI	13.1	13	14.5	14.1	18.2	13.1	14.5	14.1	18.2
OTHER DATA									
RESIN, CUBIC FEET	0.75	1	1	1.5	2	0.75	1	1	2
GRAVEL UNDERBED CF.	0.08	0.11	0.14	0.14	0.2	0.11	0.14	0.2	0.4
MINERAL TANK DIMENSIONS	8x44	9x48	10x44	10x54	1252	9x48	10x54	13x54	14x65
BRINE TANK DIMENSIONS	18x40	18x40	18x40	18x40	18x40	18x40	18x40	18x40	18X40-8"grid
DRAIN LINE FLOW CONTROL RATE GPM	1.3	1.7	2.2	2.2	3.2	3.2	4.2	6.5	7.5
BRINE LINE FLOW CONTROL RATE GPM	0.5	0.5	0.5	0.5	0.5	0.5	0.5	0.5	0.5
INJECTOR SIZE-COLOR	C-Violet	D-Red	D-Red	E-White	G-Yellow	C-Violet	D-Red	E-White	G-Yellow
INJECTOR DRAW RATE AT 35 PSI	0.135	0.21	0.21	0.25	0.41	0.135	0.21	0.25	0.41
INJECTOR SLOW RINSE RATE AT 35 PSI	0.24	0.27	0.27	0.32	0.56	0.24	0.27	0.32	0.56

Factory Settings are Bold.

Efficient Salt Settings are used on clean, iron-free water, such as city water supplies, for efficient salt use. On water supplies with turbidity and/or iron concentrations >0.5ppm, may need higher salt setting to

System conforms to ANSI/NSF 44 for specific performance claims as verified and substantiated by test data. Efficiency is measured by a laboratory test as described in ANSI/NSF 44, testing represents maximum efficiency system can achieve. Operational efficiency is achieved after system is installed and may be less than tested efficiency due to application parameters such as water hardness, TDS and other contaminants that reduce the softeners capacity.

If installation hardness is not 20 grains adjust accordingly.

TABLE 6 - PROGRAMMING OPTIONS

Reserve Gallons	Regeneration Type	Days Override	
AUTO	NORMAL	oFF	Reserve capacity automatically estimated. Regeneration occurs when gallons capacity falls below the reserve capacity at the next Regen Set Time.
AUTO	NORMAL	1 to 24	Reserve capacity automatically estimated. Regeneration occurs at the next Regen Set Time when gallons capacity falls below the reserve capacity or the specified number of days between regenerations is reached.
20 to 50,000	NORMAL	oFF	Reserve capacity <u>not</u> automatically estimated. Regeneration occurs at the next Regen Set Time when gallons capacity reaches 0.
oFF**	NORMAL**	1 to 24**	Reserve capacity <u>not</u> automatically estimated. Regeneration occurs at the next Regen Set Time when the specified number of days between regenerations is reached.
20 to 50,000	NORMAL	1 to 24	Reserve capacity <u>not</u> automatically estimated. Regeneration occurs at the next Regen Set Time when gallons capacity reaches 0 or the specified number of days between regenerations is reached.
AUTO	On 0	oFF	Reserve capacity <u>not</u> automatically estimated. Regeneration occurs immediately when gallons capacity reaches 0. Time of regeneration will not be allowed to be set because of regeneration will always occur when gallons capacity reaches 0.
20 to 50,000	On 0	oFF	Reserve capacity <u>not</u> automatically estimated. Regeneration occurs immediately when gallons capacity reaches 0. Time of regeneration will not be allowed to be set because regeneration will always occur on 0.
AUTO	NORMAL on 0	oFF	Reserve capacity automatically estimated. Regeneration occurs when gallons capacity falls below the reserve capacity at the next Regen Set Time or regeneration occurs immediately after 10 minutes of no water usage when gallon capacity reaches 0.
AUTO*	NORMAL on 0*	1 to 24 *14	Reserve capacity automatically estimated. Regeneration occurs at the next Regen Set Time when gallons capacity falls below the reserve capacity or the specified number of days between regenerations is reached or regeneration occurs immediately after 10 minutes of no water usage when gallon capacity reaches 0.
20 to 50,000	NORMAL	1 to 24	Reserve capacity <u>not</u> automatically estimated. Regeneration occurs at the next Regen Set Time when specified number of days between regenerations is reached or regeneration occurs immediately after 10 minutes of no water usage when gallon capacity reaches 0.

* Factory settings in bold

** These settings are used for time clock systems

GENERAL SPECIFICATIONS

OPERATING PRESSURES

Minimum/Maximum25 psi-120 psi

OPERATING TEMPERATURES

Minimum/Maximum40° - 110° F

METER

Accuracy.....±5%

Flow Rate Range.....0.25 - 27 GPM

Gallon Range20 - 50,000

DIMENSIONS

Drain Line3/4" or 1" NPT

Brine Line3/8" Poly Tube

ELECTRICAL CURRENT DRAW AND VOLTAGE

.....0.5A 110v

Compatible with the following regenerants or chemicals: Sodium chloride, potassium permanganate, sodium bisulfite, sodium hydroxide, hydroxide, hydrochloric acid, chlorine and chloramines.

Residential Water Softener & Filter Limited Warranty

INCLUDES – E3, H100, S12, WaterMate-1, WaterMate-2, WaterMate-3, WaterMate-3.2
EXCLUDES – Striker Filter Systems

Hellenbrand, Inc. ("Hellenbrand") warrants to the original consumer purchaser that the System and the parts listed below will be free from defects in material and/or workmanship from the date of the original installation for the following time periods:

For a Period of FIVE YEARS: The filter control valve electrical parts including the motor and board, control valve body, and internal parts.

For a Period of TEN YEARS: Mineral tanks, 6" Diameter - 13" Diameter.

For a Period of FIVE YEARS: Mineral tanks, 14" Diameter - Up.

For a Period of FIVE YEARS: The salt storage/cabinet tank.

For a Period of ONE YEAR: The entire water conditioner system ("System").

Any parts used for replacement are warranted for the remainder of the original warranty period for the applicable part.

THIS WARRANTY IS EFFECTIVE TO THE ORIGINAL CONSUMER PURCHASER ONLY, AND ONLY FOR AS LONG AS THE SYSTEM REMAINS AT THE ORIGINAL INSTALLATION SITE. COVERAGE TERMINATES IF YOU SELL OR OTHERWISE TRANSFER THE SYSTEM OR IF THE SYSTEM IS MOVED FROM THE ORIGINAL INSTALLATION SITE.

No sales representative, distributor, agent, dealer, reseller, authorized seller or any other person or entity is authorized to make any other warranty, or modify or expand the warranty provided herein on behalf of Hellenbrand. Upon expiration of the applicable warranty period, Hellenbrand shall have no further liability related to the System/parts to which the warranty period applies, except with respect to valid warranty claims asserted during the appropriate warranty period.

If the System or any part described above becomes defective within the specified warranty period, you should notify your local authorized seller of Hellenbrand products, and arrange a time during normal business hours for the inspection of the System at the original installation site. You may also contact Hellenbrand and we will provide you with the contact information for your local authorized seller of Hellenbrand products. Hellenbrand, at its option, will repair or replace the System or any part found defective within the terms of this warranty. You are responsible for freight from our factory and any service fees charged by the local authorized seller of Hellenbrand products for installation, repair, removal, replacement, service, etc., of any System or parts. This warranty does not include any labor charges. This paragraph sets forth the exclusive remedy for any valid warranty claims against Hellenbrand.

THIS WARRANTY DOES NOT COVER defects caused by sand, sediment or bacteria fouling, accident, fire, flood, Act of God, misuse, misapplication, neglect, alteration, installation or operation contrary to Hellenbrand's printed instructions, or installation, repair or service by anyone other than Hellenbrand or an authorized seller of Hellenbrand products.

IN ADDITION, THIS WARRANTY DOES NOT COVER UNPROTECTED OUTDOOR INSTALLATIONS. This System, including all of the electrical components, must be protected against windblown dust, falling and windblown rain, freezing temperatures and the formation of ice, with an appropriate enclosure consisting of a floor, roof, walls, ventilation and heat.

As a manufacturer, we do not know the characteristics of your water supply or the purpose for which you are purchasing this system. You should be aware that the quality of water supplies may vary seasonally or over a period of time, and that your water usage rate may vary as well. Water characteristics may change considerably if this System is moved to a new location. For these reasons, Hellenbrand assumes no liability for the determination of the proper equipment necessary to meet your needs; and Hellenbrand does not authorize others to assume such obligations for Hellenbrand.

TO THE EXTENT PERMITTED BY APPLICABLE LAW, REMEDIES FOR DEFECTS OR FAILURES ARE LIMITED TO THE REMEDIES PROVIDED IN THIS WARRANTY. THERE ARE NO EXPRESS WARRANTIES OTHER THAN THOSE SET FORTH HEREIN. ANY IMPLIED WARRANTIES, INCLUDING WITHOUT LIMITATION WARRANTIES OF MERCHANTABILITY, FITNESS FOR PARTICULAR PURPOSE, NON-INFRINGEMENT, OR ANY WARRANTIES ARISING FROM COURSE OF PERFORMANCE, COURSE OF DEALING, OR FROM USAGES OF TRADE, ARE LIMITED IN DURATION TO THE APPLICABLE WARRANTY PERIOD SET FORTH ABOVE.

UNDER NO CIRCUMSTANCES SHALL HELLENBRAND BE LIABLE TO THE ORIGINAL CONSUMER PURCHASER OR TO ANY OTHER PERSON FOR ANY INCIDENTAL, INDIRECT, SPECIAL OR CONSEQUENTIAL DAMAGES OR FOR ANY OTHER LOSS, DAMAGE, OR EXPENSE OF ANY KIND, INCLUDING LOSS OF PROFITS, WHETHER ARISING OUT OF BREACH OF WARRANTY, BREACH OF CONTRACT, IN TORT OR OTHERWISE, AND REGARDLESS OF WHETHER HELLENBRAND WAS AWARE OF THE POSSIBILITY OF SUCH LOSS. THESE LIMITATIONS WILL APPLY REGARDLESS OF ANY FAILURE OF ESSENTIAL PURPOSE OF ANY LIMITED REMEDY.

Some states do not allow limitations on how long an implied warranty lasts, so the above limitations may not apply to you. Similarly, some states do not allow the exclusion or limitation of incidental or consequential damages, so the above limitation or exclusion may not apply to you. This warranty gives you specific legal rights, and you may also have other rights which vary from state to state.