

# SCALA

## Installation and operating instructions

CLICK ANYWHERE on THIS PAGE to RETURN TO GRUNDFOS SCALA 2 PUMP GUIDE at [InspectApedia.com](https://www.inspectApedia.com)



## English (GB) Installation and operating instructions

### Original installation and operating instructions

These installation and operating instructions describe Grundfos SCALA domestic water supply pumps.

Sections 1-4 give the information necessary to be able to unpack, install and start up the product in a safe way.

Sections 5-14 give important information about the product, as well as information on service, fault finding and disposal of the product.

### CONTENTS

|  | Page      |
|--|-----------|
| <b>1. General information</b>                                  | <b>2</b>  |
| 1.1 Target group   | 2         |
| 1.2 Symbols used in this document                              | 2         |
| <b>2. Receiving the product</b>                                | <b>3</b>  |
| 2.1 Inspecting the product                                     | 3         |
| 2.2 Scope of delivery  | 3         |
| <b>3. Installing the product</b>                               | <b>3</b>  |
| 3.1 Location   | 3         |
| 3.2 System sizing  | 3         |
| 3.3 Mechanical installation                                    | 3         |
| 3.4 Foundation   | 3         |
| 3.5 Installation examples                                      | 4         |
| 3.6 Suction pipe length  | 5         |
| 3.7 Electrical connection                                      | 5         |
| <b>4. Starting up the product</b>                              | <b>5</b>  |
| 4.1 Priming the pump   | 5         |
| 4.2 Starting the pump  | 5         |
| 4.3 Shaft seal run-in  | 6         |
| <b>5. Storing and handling the product</b>                     | <b>6</b>  |
| 5.1 Handling   | 6         |
| 5.2 Storing  | 6         |
| 5.3 Winterizing  | 6         |
| <b>6. Product introduction</b>                                 | <b>6</b>  |
| 6.1 Product description  | 6         |
| 6.2 Application  | 6         |
| 6.3 Pumped liquids   | 6         |
| 6.4 Identification   | 7         |
| <b>7. Control functions</b>                                    | <b>8</b>  |
| 7.1 Menu overview, SCALA2                                      | 8         |
| <b>8. Operating the controller</b>                             | <b>9</b>  |
| 8.1 Setting the outlet pressure                                | 9         |
| 8.2 Locking and unlocking the operating panel                  | 9         |
| 8.3 Expert settings, SCALA2                                    | 9         |
| 8.4 Resetting to factory settings                              | 9         |
| <b>9. Starting up the product after shutdown or standstill</b> | <b>10</b> |
| 9.1 Deblocking the pump  | 10        |
| 9.2 Controller settings  | 10        |
| 9.3 Priming  | 10        |
| <b>10. Servicing the product</b>                               | <b>10</b> |
| 10.1 Maintaining the product                                   | 10        |
| 10.2 Customer service information                              | 11        |
| 10.3 Service kits  | 11        |
| <b>11. Taking out of operation</b>                             | <b>11</b> |
| <b>12. Fault finding the product</b>                           | <b>11</b> |
| 12.1 Grundfos Eye operating indications                        | 11        |
| 12.2 Fault resetting   | 11        |
| 12.3 Fault finding chart                                       | 12        |
| <b>13. Technical data</b>                                      | <b>14</b> |
| 13.1 Operating conditions                                      | 14        |
| 13.2 Mechanical data   | 14        |
| 13.3 Electrical data   | 14        |
| <b>14. Disposal</b>  | <b>14</b> |



#### Warning

Prior to installation, read this document and the quick guide. Installation and operation must comply with local regulations and accepted codes of good practice.

#### Warning

This product can be used by children of eight years and up and persons with reduced physical, sensory or mental capabilities or lack of experience and knowledge if they are under supervision or have been instructed in the safe use of the product and understand the hazards involved.

Children must not play with the product.

Cleaning and maintenance of the product must not be made by children without supervision.



#### Caution

This pump has been evaluated for use with water only.

#### Warning

Risk of electric shock.

This pump has a grounding conductor and grounding-type attachment plug. To reduce the risk of electric shock, be certain that the pump is connected only to a properly grounded, grounding-type receptacle.



## 1. General information

### 1.1 Target group

These installation and operating instructions are intended for professional installers.

### 1.2 Symbols used in this document



#### Warning

If these safety instructions are not observed, it may result in personal injury.



#### Warning

If these instructions are not observed, it may lead to electric shock with consequent risk of serious personal injury or death.

#### Caution

If these safety instructions are not observed, it may result in malfunction or damage to the equipment.

#### Note

Notes or instructions that make the job easier and ensure safe operation.

## 2. Receiving the product

### 2.1 Inspecting the product

Check that the product received is in accordance with the order. Check that the voltage and frequency of the product match voltage and frequency of the installation site. See section [6.4.1 Nameplate](#).

### 2.2 Scope of delivery

The box contains the following items:

- 1 Grundfos SCALA pump
- 1 quick guide
- 1 safety instructions booklet.

## 3. Installing the product

### 3.1 Location

The pump can be installed indoors or outdoors, but it must not be exposed to frost.

We recommend that you install the pump near a drain or in a drip tray connected to a drain in order to lead away possible condensation from cold surfaces.

If the unlikely event of an internal leakage occurs, the liquid will be drained through the bottom of the pump and/or through the pump cover instead of causing damage to the pump.

#### Caution

Install the pump in such a way that no undesirable collateral damage can arise.

#### 3.1.1 Minimum space

The pump requires a minimum space of 430 x 215 x 325 mm (17 x 8.5 x 12.8 inches).

Even though the pump does not require much space, we recommend that you leave enough space for service and maintenance access.

#### 3.1.2 Installing the product in frosty environment

Protect the pump from freezing if it is to be installed outdoors where frost may occur.

### 3.2 System sizing



#### Warning

The system in which the pump is incorporated must be designed for the maximum pump pressure.

The pump is factory-set to three bar outlet pressure which can be adjusted according to the system in which it is incorporated.

The tank precharge pressure is 1.25 bar (18 psi).

In case of suction lift of more than six metres, the pipe resistance on the outlet side must be at least two metres water column or 3 PSI at any given flow in order to obtain optimum operation.

### 3.3 Mechanical installation



#### Warning

Before starting any work on the product, make sure that the power supply has been switched off and that it cannot be accidentally switched on.

### 3.4 Foundation

Fasten the pump to a solid horizontal foundation by means of screws through the holes in the base plate. See figures 2 and 1.

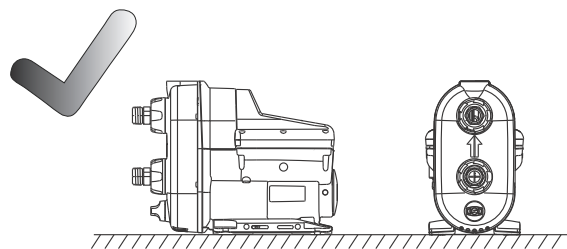

Fig. 1 Horizontal foundation

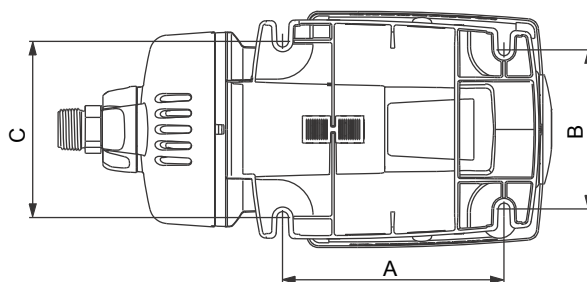

Fig. 2 Base plate

|   |        |             |
|---|--------|-------------|
| A | 130 mm | 5.12 inches |
| B | 181 mm | 7.13 inches |
| C | 144 mm | 5.67 inches |

#### 3.4.1 Pipework

Make sure that the pump is not stressed by the pipework.

The pumps are equipped with flexible connections,  $\pm 5^\circ$ , to facilitate the connection of inlet and outlet pipes. The inlet and outlet ports can be loosened by turning the union nuts by hand.

#### Caution

Always loosen and tighten inlet and outlet union nuts by hand.

1. Carefully screw the inlet and outlet connections on to the inlet and outlet ports using a pipe wrench or similar tool.
2. Then fit the connections to the inlet and outlet holding the connections with one hand, and tightening the union nuts with the other hand. See fig. 3.

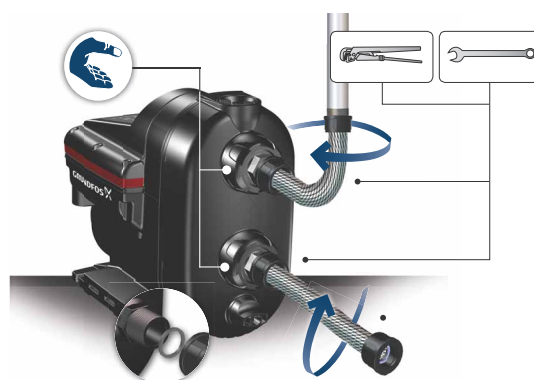

Fig. 3 How to fit the connections

TM06 5729 5315

TM06 3809 1015

TM06 4318 1915

### 3.4.2 How to reduce noise in the installation

Vibrations from the pump may be transferred to the surrounding structure and create noise in the 20-1000 Hz spectrum, also called the bass spectrum.

Correct installation using a vibration-damping rubber pad, flexible hoses and correctly placed pipe hangers for rigid pipes can reduce the noise experienced by up to 50 %. See fig. 4.

Place pipe hangers for the rigid pipes close to the connection of the flexible hose.

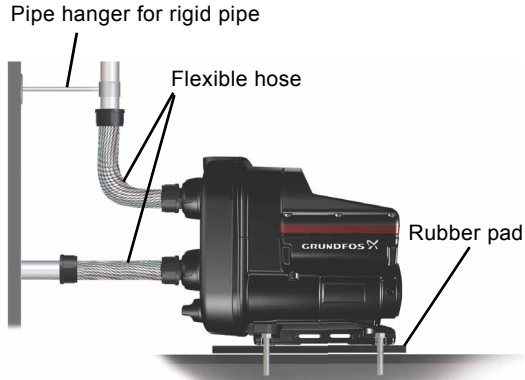

Fig. 4 How to reduce noise in the installation

### 3.5 Installation examples

Fittings, hoses and valves are not supplied with the pump.

#### 3.5.1 Mains water pressure boosting

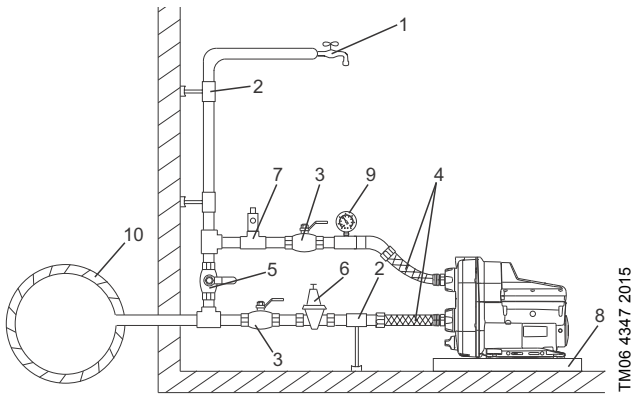

Fig. 5 Mains water pressure boosting

| Pos. | Description   |
|------|---|
| 1    | Highest tapping point   |
| 2    | Pipe hangers and supports   |
| 3    | Isolating valves  |
| 4    | Flexible hoses  |
| 5    | Bypass valve  |
| 6    | Optional pressure-reducing valve on the inlet side if the inlet pressure can exceed 10 bar (145 psi)                  |
| 7    | Optional pressure-relief valve on the outlet side if the installation cannot stand up to a pressure of 6 bar (87 psi) |
| 8    | Drip tray. Install the pump on a small stand to avoid the ventilation holes from being flooded.                       |
| 9    | Pressure gauge  |
| 10   | Mains water pipe  |

#### 3.5.2 Suction from a well

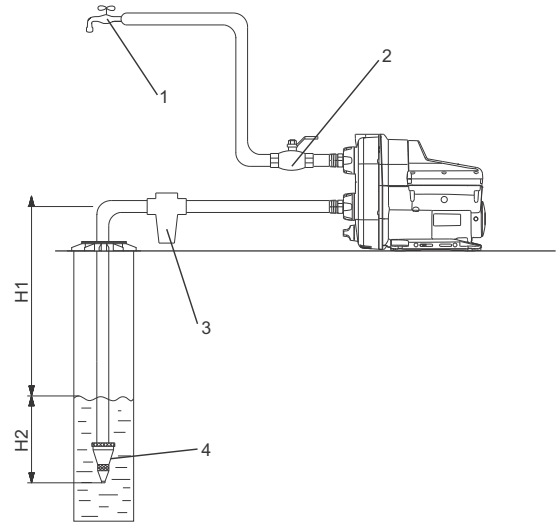

Fig. 6 Suction from a well

| Pos. | Description   |
|------|---|
| 1    | Highest tapping point   |
| 2    | Isolating valve   |
| 3    | Inlet filter.<br>If the water can contain sand, gravel or other debris, please install a filter on the inlet side to protect the pump and installation. |
| 4    | Foot valve with strainer  |
| H1   | Maximum suction lift is 8 m (29 ft)   |
| H2   | Inlet pipe must be submersed at least 0.5 m (1.64 ft)   |

#### 3.5.3 Suction from freshwater tank

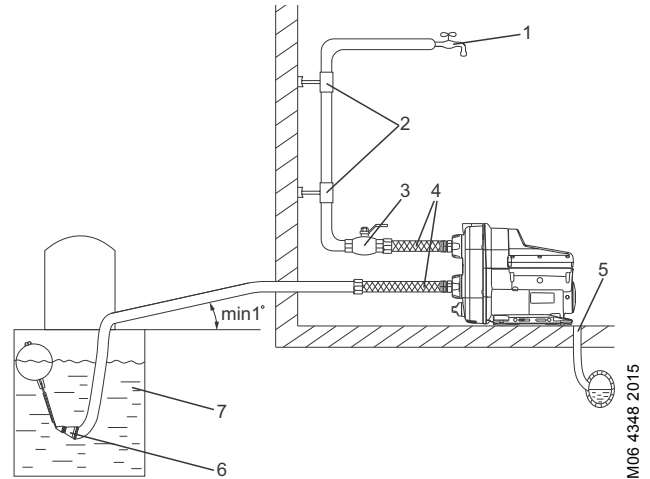

Fig. 7 Suction from freshwater tank

| Pos. | Description              |
|------|--------------------------|
| 1    | Highest tapping point    |
| 2    | Pipe hangers             |
| 3    | Isolating valve          |
| 4    | Flexible hoses           |
| 5    | Drain to sewer           |
| 6    | Foot valve with strainer |
| 7    | Freshwater tank          |

### 3.6 Suction pipe length

The overview below shows the different possible pipe lengths, depending on the vertical pipe length.

The overview is only intended as a guide.

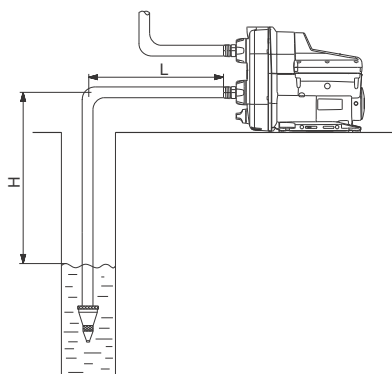

Fig. 8 Suction pipe length

TM06 4372 2115

| DN 32         |               | DN 40         |               |
|---------------|---------------|---------------|---------------|
| H<br>[m (ft)] | L<br>[m (ft)] | H<br>[m (ft)] | L<br>[m (ft)] |
| 0 (0)         | 68 (223)      | 0 (0)         | 207 (679)     |
| 3 (10)        | 43 (141)      | 3 (10)        | 129 (423)     |
| 6 (20)        | 17 (56)       | 6 (20)        | 52 (171)      |
| 7 (23)        | 9 (30)        | 7 (23)        | 26 (85)       |
| 8 (26)        | 0 (0)         | 8 (26)        | 0 (0)         |

#### Preconditions:

Maximum flow velocity: 1 l/s (16 gpm)

Inside roughness of pipes: 0.01 mm (0.0004 inch).

| Size  | Inside pipe diameter | Pressure loss               |
|-------|----------------------|-----------------------------|
| DN 32 | 28 mm (1.1 inches)   | 0.117 m/m (5 psi/100 ft)    |
| DN 40 | 35.2 mm (1.4 inches) | 0.0387 m/m (1.6 psi/100 ft) |

### 3.7 Electrical connection

#### 3.7.1 Plug connection



**Warning**  
Check that the voltage and frequency of the product match voltage and frequency of the installation site.



**Warning**  
If the power supply cable is damaged, it must be replaced by the manufacturer, his service agent or similarly qualified persons in order to avoid hazard.



**Warning**  
As a precaution, the product must be connected to a socket with earth connection.

**Note**

We recommend that you fit the permanent installation with an earth leakage circuit breaker (ELCB) with a tripping current < 30 mA.

The pump incorporates current and temperature dependent motor protection.

#### 3.7.2 Connections without plug



**Warning**  
The electrical connection must be carried out by an authorised electrician in accordance with local regulations.



**Warning**  
Before making any connections in the product, make sure that the power supply has been switched off and that it cannot be accidentally switched on.  
The product must be connected to an external mains switch with a contact gap of at least 3 mm (0.12 inch) in all poles.

### 4. Starting up the product

**Caution**

Do not start the pump until it has been filled with liquid.

#### 4.1 Priming the pump

1. Unscrew the priming plug and pour minimum 1.7 litres (0.45 gallons) of water into the pump housing. See fig. 9.
2. Screw the priming plug on again.

**Note**

If the suction depth exceeds 6 m (20 ft), it may be necessary to prime the pump more than once.

**Caution**

Always tighten priming and drain plugs by hand.

#### 4.2 Starting the pump

1. Open a tap to prepare the pump for venting.
  2. Insert the power plug into the socket or turn on the power supply and the pump will start.
  3. When water flows without air, close the tap.
  4. Open the highest tapping point in the installation, preferably a shower.
  5. Adjust the pressure to the required pressure by means of the  buttons.
  6. Close the tapping point.
- Startup has been completed.



Fig. 9 Priming the pump

TM06 4204 1615

### 4.3 Shaft seal run-in

The shaft-seal faces are lubricated by the pumped liquid, meaning that there may be a certain amount of leakage from the shaft seal.

When the pump is started up for the first time, or when the shaft seal has been replaced, a certain run-in period is required before the leakage is reduced to an acceptable level. The time required for this depends on the operating conditions, that is, every time the operating conditions change, a new run-in period will be started.

Under normal conditions, the leaking liquid will evaporate. As a result, no leakage will be detected.

## 5. Storing and handling the product

### 5.1 Handling

**Caution** Take care not to drop the pump as it may break.

### 5.2 Storing

In case the pump is to be stored for a period of time, drain it and store it in a dry location.

Temperature range during storing must be -40 to 70 °C (104 to 158 °F).

### 5.3 Winterizing

If the pump is going to be out of operation during the winter and can be exposed to frost, it must be disconnected from the power supply and winterized.

Proceed as follows:

1. Stop the pump by means of the on/off button .
2. Disconnect the power supply.
3. Open a tap to release the pressure in the pipe system.
4. Close the isolating valves and/or drain the pipes.
5. Gradually loosen the priming plug to release the pressure in the pump.
6. Remove the drain plug to drain the pump. See fig. 10.



Fig. 10 Draining the pump

#### 5.3.1 Startup after the winter

Check that the pump is not blocked by following the steps in section 9.1 [Deblocking the pump](#).

See section 4. [Starting up the product](#).

## 6. Product introduction

### 6.1 Product description

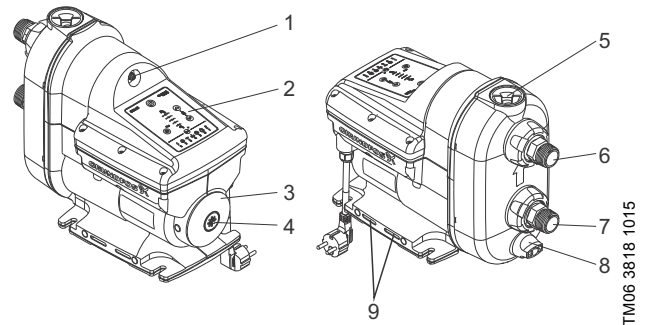

Fig. 11 Grundfos SCALA pump

| Pos. | Description  |
|------|--|
| 1    | Air valve for built-in pressure tank   |
| 2    | Operating panel. See section 7. <a href="#">Control functions</a> .                                  |
| 3    | Nameplate. See section 6.4.1 <a href="#">Nameplate</a> .   |
| 4    | Plug for access to pump shaft. See section 9.1 <a href="#">Deblocking the pump</a> .                 |
| 5    | Priming plug. See section 4.1 <a href="#">Priming the pump</a> .                                     |
| 6    | Outlet opening. With $\pm 5^\circ$ flexible connection. See section 3.4.1 <a href="#">Pipework</a> . |
| 7    | Inlet opening. With $\pm 5^\circ$ flexible connection. See section 3.4.1 <a href="#">Pipework</a> .  |
| 8    | Drain plug. See section 5.3 <a href="#">Winterizing</a> .  |
| 9    | Ventilation holes. Must not be flooded.  |

### 6.2 Application

The pump is suitable for pressure boosting of fresh water in domestic water supply systems.

### 6.3 Pumped liquids

The pump is designed for clean fresh water and chlorinated water < 300 ppm.

TM06 4203 1615

TM06 3818 1015

## 6.4 Identification

### 6.4.1 Nameplate

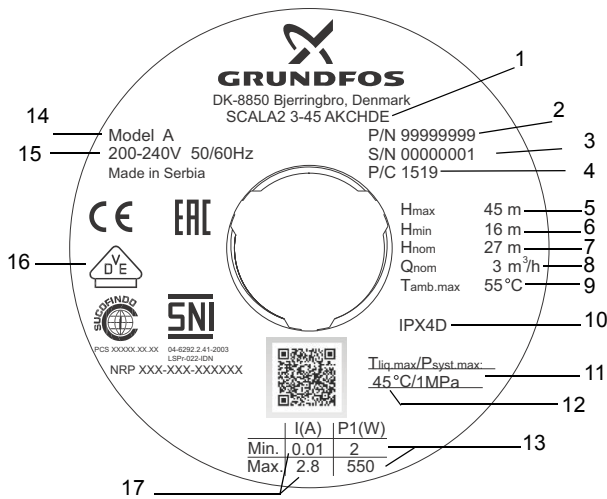

TM06 4340 2015

Fig. 12 Example of nameplate

| Pos. | Description                       |
|------|-----------------------------------|
| 1    | Type designation                  |
| 2    | Product number                    |
| 3    | Serial number                     |
| 4    | Production code (year and week)   |
| 5    | Maximum head                      |
| 6    | Minimum head                      |
| 7    | Rated head                        |
| 8    | Rated flow rate                   |
| 9    | Maximum ambient temperature       |
| 10   | IP class                          |
| 11   | Maximum operation pressure        |
| 12   | Maximum liquid temperature        |
| 13   | Minimum and maximum rated power   |
| 14   | Model                             |
| 15   | Voltage and frequency             |
| 16   | Approvals                         |
| 17   | Minimum and maximum rated current |

### 6.4.2 Type key

|                             | SCALA2 | 3  | -45 | A | K | C | H | D | E |
|-----------------------------|--------|--|-----|---|---|---|---|---|---|
| <b>Type range</b>           | SCALA1 | Economy  |     |   |   |   |   |   |   |
|                             | SCALA2 | Comfort  |     |   |   |   |   |   |   |
| <b>Rated flow rate</b>      | 3:     | [m <sup>3</sup> /h]                            |     |   |   |   |   |   |   |
| <b>Maximum head</b>         | 45:    | [m]  |     |   |   |   |   |   |   |
| <b>Material code</b>        | A:     | Standard                                       |     |   |   |   |   |   |   |
| <b>Supply voltage</b>       | K:     | 1 x 200-240 V, 50/60 Hz                        |     |   |   |   |   |   |   |
|                             | M:     | 1 x 208-230 V, 60 Hz                           |     |   |   |   |   |   |   |
|                             | V:     | 1 x 115 V, 60 Hz                               |     |   |   |   |   |   |   |
|                             | W:     | 1 x 100-115 V, 50/60 Hz                        |     |   |   |   |   |   |   |
| <b>Motor</b>                | C:     | High-efficiency motor with frequency converter |     |   |   |   |   |   |   |
| <b>Mains cable and plug</b> | A:     | Cable with plug, IEC type I, AS/NZS3112, 2 m   |     |   |   |   |   |   |   |
|                             | B:     | Cable with plug, IEC type B, NEMA 5-15P, 6 ft  |     |   |   |   |   |   |   |
|                             | C:     | Cable with plug, IEC, type E&F, CEE7/7, 2 m    |     |   |   |   |   |   |   |
|                             | D:     | Cable without plug, 2 m                        |     |   |   |   |   |   |   |
|                             | G:     | Cable with plug, IEC type G, BS1363, 2 m       |     |   |   |   |   |   |   |
|                             | H:     | Cable with plug, IEC type I, IRAM 2073, 2 m    |     |   |   |   |   |   |   |
|                             | J:     | Cable with plug, NEMA 6-15P, 6 ft              |     |   |   |   |   |   |   |
| <b>Controller</b>           | D:     | Integrated frequency converter                 |     |   |   |   |   |   |   |
| <b>Thread</b>               | A:     | R 1" EN 1.4308                                 |     |   |   |   |   |   |   |
|                             | C:     | NPT 1" EN 1.4308                               |     |   |   |   |   |   |   |
|                             | E:     | R 1" composite material                        |     |   |   |   |   |   |   |
|                             | F:     | NPT 1" composite material                      |     |   |   |   |   |   |   |

## 7. Control functions

### 7.1 Menu overview, SCALA2



Fig. 13 SCALA2 operating panel

| SCALA2 | Function  |
|--------|---|
|        | On/off  |
|        | Increases the outlet pressure                     |
|        | Decreases the outlet pressure                     |
|        | Resets alarms                                     |
|        | Indicates the required outlet pressure            |
|        | Indicates that the pump has been stopped manually |
|        | Indicates that the operating panel is locked      |

#### 7.1.1 Pressure indicator, SCALA2

The pressure indicator shows the required outlet pressure from 1.5 to 5.5 bars (22 to 80 psi) in 0.5 bar (7.5 psi) intervals. The illustration below shows a pump set to 3 bar (44 psi) indicated by two green lights and a pump set to 3.5 bar (51 psi) indicated by one green light.

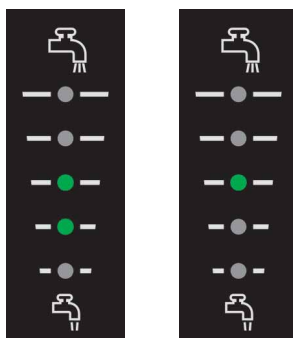

Fig. 14 SCALA2 outlet pressure indication

|  | BAR | PSI | Water column [m] | kPa | MPa  |
|--|-----|-----|------------------|-----|------|
|  | 5.5 | 80  | 55               | 550 | 0.55 |
|  | 5.0 | 73  | 50               | 500 | 0.50 |
|  | 4.5 | 65  | 45               | 450 | 0.45 |
|  | 4.0 | 58  | 40               | 400 | 0.40 |
|  | 3.5 | 51  | 35               | 350 | 0.35 |
|  | 3.0 | 44  | 30               | 300 | 0.30 |
|  | 2.5 | 36  | 25               | 250 | 0.25 |
|  | 2.0 | 30  | 20               | 200 | 0.20 |
|  | 1.5 | 22  | 15               | 150 | 0.15 |

TM06 4187 1615

Fig. 15 Pressure indication table

The pressure settings 4.5, 5.0 and 5.5 bar (65, 73 and 80 psi) require a minimum positive inlet pressure which is maximum 4 bar (58 psi) lower than the required outlet pressure.

**Note**

Example: If the required outlet pressure is 5 bar, the minimum inlet pressure must be 1 bar (14.5 psi).

#### 7.1.2 Indicator lights, SCALA2

| Indications | Description  |
|-------------|--|
|             | Operating indications  |
|             | The operating panel is locked  |
|             | Power supply failure   |
|             | The pump is blocked, e.g. the shaft seal has seized up                   |
|             | Leakage in the system  |
|             | Dry-running or water shortage*   |
|             | The maximum pressure has been exceeded or the setpoint cannot be reached |
|             | The maximum runtime has been exceeded                                    |
|             | The temperature is outside the range                                     |

\* For fault number 4, dry-running, the pump must be reset manually. For fault number 4, water shortage, and the remaining faults, 1, 2, 3, 5, 6 and 7, the pump will reset whenever the cause has disappeared or been remedied. See section [8.3.2 Auto reset](#).

For further information about system status, see section [12.1 Grundfos Eye operating indications](#).



TM06 3301 5114

TM06 4345 2015



## 8. Operating the controller



### 8.1 Setting the outlet pressure

Adjust the outlet pressure by pressing  .



### 8.2 Locking and unlocking the operating panel

The operating panel can be locked, which means that the buttons do not function and no settings can be changed accidentally.

#### How to lock the operating panel

1. Hold down the   buttons simultaneously for three seconds.
2. The operating panel is locked when  symbol lights up.

#### How to unlock the operating panel

1. Hold down the   buttons simultaneously for three seconds.
2. The operating panel is unlocked when  symbol turns off.



### 8.3 Expert settings, SCALA2



**Note** Expert settings are for installers only.



The expert setting menu allows the installer to toggle between the functions "Auto reset", "Anti cycling" and "Maximum continuous operating time".

#### 8.3.1 Accessing the expert settings

Proceed as follows:

1. Hold down the  button for five seconds.
2. The  symbol will start flashing to indicate that the expert settings are active.

The pressure indicator now acts as the expert "menu". A flashing green diode is the cursor. Move the cursor using the   buttons, and toggle the selection on or off using the  button. The diode for each setting will light up when the setting is active.

|   |                  |
|---|------------------|
|  | Move cursor up   |
|  | Move cursor down |
|  | Toggle settings  |

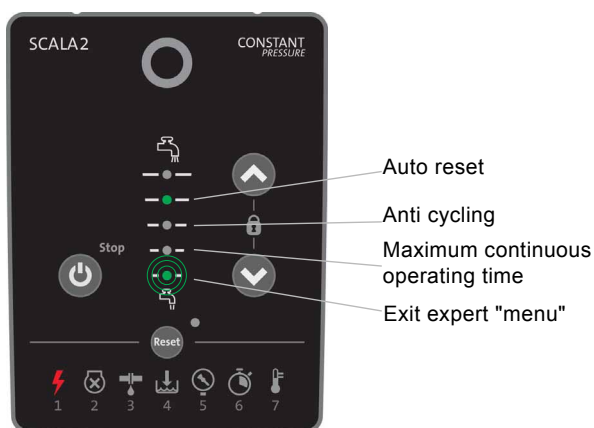

Fig. 16 Expert "menu" overview

TM06 4346 2015

#### 8.3.2 Auto reset

The factory setting for "Auto reset" is "on".

**On:**

This function allows the pump to automatically check if the operating conditions are back to normal. If the operating conditions are back to normal, the alarm indication will be reset automatically.

The "Auto reset" function works in the following way:

| Indication                    | Action   |
|-------------------------------|--|
| Water shortage                | The pump will attempt eight restarts at five-minute intervals. If not successful, this cycle will be repeated after 24 hours.  |
| Dry running (pump not primed) | Prime the pump and reset it manually.  |
| All other indications         | The pump will attempt three restarts within the first 60 seconds, then eight restart attempts at five-minute intervals. If not successful, this cycle will be repeated after 24 hours. |

For indications, see section [7.1.2 Indicator lights, SCALA2](#).

**Off:**

All alarms must be reset manually by means of the  button.

#### 8.3.3 Anti cycling

The factory setting for "Anti cycling" is "off".

This function monitors the stops and starts of the pump.

**Off:**

If the pump starts 40 times in a fixed pattern, there will be an alarm. The pump will remain in operation as normal.

**On:**

If the pump starts and stops in a fixed pattern, there is a leakage in the system, and the pump will stop and show alarm 3.



Leakage in the system.

#### 8.3.4 Maximum continuous operating time

The factory setting for "Maximum continuous operating time" is "off".

This function is a timer that can turn off the pump if it runs continuously for 30 minutes.

**Off:**

If the pump exceeds the running time of 30 minutes, the pump will run depending on the flow.



**On:**

If the pump exceeds the running time of 30 minutes, the pump will stop after 30 minutes of continuous operation, and it will show alarm 6. This alarm will always need to be reset manually.



Maximum runtime exceeded.

## 8.4 Resetting to factory settings

The pump can be reset to factory setting by pressing the   buttons simultaneously for five seconds.

## 9. Starting up the product after shutdown or standstill

### 9.1 Deblocking the pump



#### Warning

Before starting any work on the product, make sure that the power supply has been switched off and that it cannot be accidentally switched on.

The end cover incorporates a plug which can be removed by means of a suitable tool. This makes it possible to deblock the pump shaft if it has seized up as a result of inactivity.

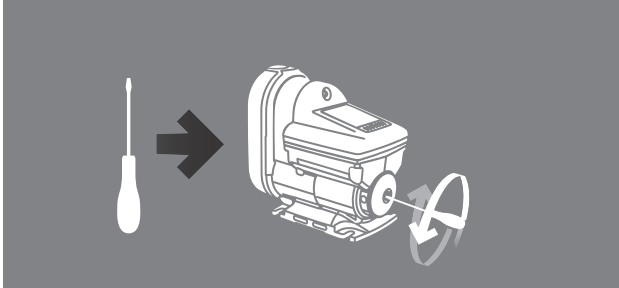

Fig. 17 Deblocking the pump

### 9.2 Controller settings

The pump will remember the controller settings even if it is turned off.

### 9.3 Priming

If the pump has been drained, it must be filled with liquid before startup. See section 4. *Starting up the product*.

## 10. Servicing the product



#### Warning

Before starting any work on the product, make sure that the power supply has been switched off and that it cannot be accidentally switched on.

### 10.1 Maintaining the product

#### 10.1.1 Insect filter

The pump has an insect filter to prevent insects from nesting in the pump.

The filter is placed on the bottom and can easily be removed and cleaned with a stiff brush. See fig. 18.

Clean the insect filter once a year or as needed.

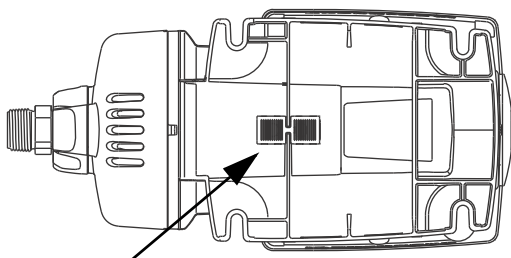

Fig. 18 Insect filter

#### 10.1.2 Inlet and outlet valves

The pump is maintenance-free, but we recommend that you check and clean the inlet and outlet non-return valves once a year or as needed.

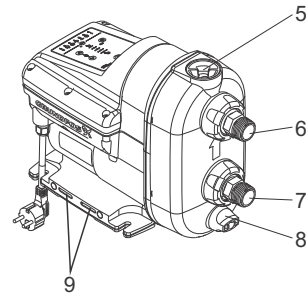

Fig. 19 SCALA pump

To remove the inlet non-return valve, follow the steps below:

1. Turn off the power supply and disconnect the power plug.
2. Shut off the water source.
3. Open a tap to release the pressure in the pipe system.
4. Close the isolating valves and/or drain the pipes.
5. Gradually open and remove the priming plug. See fig. 19 (5).
6. Remove the drain plug and drain the pump. See fig. 19 (8).
7. Unscrew the union nut holding the inlet connection. See fig. 19 (7). Depending on the installation type, it may be necessary to remove the pipes from both the inlet and outlet connections.
8. Pull out the inlet connection.
9. Pull out the inlet non-return valve.
10. Clean the non-return valve with warm water and a soft brush.
11. Assemble the components in reverse order.

To remove the outlet non-return valve, follow the steps below:

1. Turn off the power supply and disconnect the power plug.
2. Shut off the water source.
3. Open a tap to release the pressure in the pipe system.
4. Close the isolating valves and/or drain the pipes.
5. Gradually open and remove the priming plug. See fig. 19 (5). The plug and non-return valve are one unit.
6. Clean the non-return valve with warm water and a soft brush.
7. Assemble the components in reverse order.



Fig. 20 Outlet and inlet non-return valves

TM06 3818 1015

TM06 4202 1615

TM06 4637 2515

TM06 4331 1915

## 10.2 Customer service information

For further information on service parts, see Grundfos Product Center on [www.product-selection.grundfos.com](http://www.product-selection.grundfos.com).

## 10.3 Service kits







For further information on service kits, see Grundfos Product Center on [www.grundfos.com](http://www.grundfos.com).

## 11. Taking out of operation

For further information on how to take the product out of operation, see end-of-life documentation on [www.grundfos.com](http://www.grundfos.com).

## 12. Fault finding the product

### 12.1 Grundfos Eye operating indications

| Grundfos Eye  | Indication   | Description                                   |
|---|--|---|
|    | No lights are on.  | The power is off.<br>The pump is not running. |
|    | Two opposite green indicator lights running in the direction of rotation of the pump.                          | The power is on.<br>The pump is running.      |
|    | Two opposite green indicator lights at a 45° angle is the icon used throughout this document for pump running. | The power is on.<br>The pump is running.      |
|  | Two opposite green indicator lights permanently on.  | The power is on.<br>The pump is not running.  |
|  | Two opposite red indicator lights flashing simultaneously.   | Alarm.<br>The pump has stopped.               |
|  | Two opposite red indicator lights is the icon used throughout this document for pump stopped.                  | Alarm.<br>The pump has stopped.               |

### 12.2 Fault resetting

You can reset a fault indication in one of the following ways:

















- When you have eliminated the fault cause, reset the pump manually by pressing the  button. The pump will then revert to normal duty.
- If the fault disappears by itself, the pump will attempt to reset automatically and the fault indication will disappear if automatic reset is successful and provided that you have enabled "Auto reset" in the service menu.

## 12.3 Fault finding chart



Warning  
Before starting fault finding, switch off the power supply.  
Make sure that the power supply cannot be accidentally switched on.

| Fault                                | Grundfos Eye | Indicator light | Automatic reset | Cause  | Remedy   |
|--------------------------------------|--------------|-----------------|-----------------|--|--|
| 1. The pump is not running.          |              | -               | -               | a) Power supply failure  | Switch on the power supply. Check the cables and cable connections for defects and loose connections and check for blown fuses in the electrical installation. |
|                                      |              |                 | Yes             | b) The power supply is out of prescribed voltage range   | Check the power supply and the pump nameplate. Reestablish the power supply within the prescribed voltage range.   |
|                                      |              |                 | No              | c) The shaft seal has seized up  | See section 9. <i>Starting up the product after shutdown or standstill.</i>  |
|                                      |              |                 | No              | d) The pump is blocked by impurities   | See section 9. <i>Starting up the product after shutdown or standstill.</i> Contact Grundfos Service if the problem persists.                                  |
|                                      |              |                 | Yes             | e) Dry running   | Check the water source, and prime the pump.  |
|                                      |              |                 | No              | f) The maximum runtime has been exceeded   | Check the installation for leakage and reset the alarm.  |
|                                      |              |                 | No              | g) The internal non-return valve is defective or blocked in completely or partly open position | Clean, repair or replace the non-return valve. See section 10. <i>Servicing the product.</i>   |
| 2. The pump is running.              |              |                 | -               | a) Leakage from the pipework, or the non-return valve is not properly closed due to impurities | Check and repair the pipework, or clean, repair or replace the non-return valve.   |
|                                      |              |                 | -               | b) Small continuous consumption  | Check the taps and reconsider the usage pattern (ice machines, water evaporators for air-conditioning, etc.).  |
|                                      |              |                 | -               | c) The temperature is below freezing point   | Consider protecting the pump and the installation against frost.   |
| 3. Pump performance is insufficient. |              | -               | -               | a) The pump inlet pressure is too low  | Check the inlet conditions of the pump.  |
|                                      |              | -               | -               | b) The pump is undersized.   | Replace the pump with a bigger pump.   |
|                                      |              | -               | -               | c) The inlet pipe, the inlet strainer or the pump is partly blocked by impurities              | Clean the inlet pipe or the pump.  |
|                                      |              | -               | -               | d) Leakage in the inlet pipe   | Repair the inlet pipe.   |
|                                      |              | -               | -               | e) Air in the inlet pipe or the pump   | Prime the inlet pipe and the pump. Check the inlet conditions of the pump.   |
|                                      |              | -               | -               | f) The required outlet pressure is too low for the installation                                | Increase the pressure setting (arrow up).  |
|                                      |              |                 | Yes             | g) The maximum temperature has been exceeded and the pump is running at reduced performance    | Check the cooling conditions. Protect the pump against direct sunlight or any nearby heat sources.   |

| Fault  | Grundfos Eye  | Indicator light   | Automatic reset | Cause   | Remedy  |
|--|---|---|-----------------|---|---|
| 4. System overpressure.  |    |    | Yes             | a) The setpoint has been set too high. The difference between the outlet pressure and the inlet pressure must not exceed 4 bar (58 psi).<br><b>Example:</b> If the required outlet pressure is 5 bar (73 psi), the minimum inlet pressure must be 1 bar (14.5 psi). | Reduce the setpoint to 4 bar (58 psi) + positive inlet pressure.            |
|  |   |   | Yes             | b) The maximum pressure has been exceeded - the inlet pressure is higher than 6 bar, 0.6 MPa (87 psi)   | Check the inlet conditions.   |
|  |   |   | Yes             | c) The maximum pressure has been exceeded - equipment elsewhere in the system causes a high pressure at the pump (e.g. water heater or defective safety equipment)  | Check the installation.   |
| 5. You can reset the pump, but it runs only for a few seconds.                   |    |    | Yes             | a) Dry running or water shortage  | Check the water source, and prime the pump.                                 |
|  |    |    | Yes             | b) The inlet pipe is blocked by impurities  | Clean the inlet pipe.   |
|  |   |   | Yes             | c) The foot or non-return valve is blocked in closed position   | Clean, repair or replace the foot or non-return valve.                      |
|  |  |  | Yes             | d) Leakage in the inlet pipe  | Repair the inlet pipe.  |
|  |  |  | Yes             | e) Air in the inlet pipe or the pump  | Prime the inlet pipe and the pump. Check the inlet conditions of the pump.  |
| 6. You can reset the pump, but it starts repeatedly, immediately after stopping. |  |  | No              | a) The internal non-return valve is defective or blocked in completely or partly open position.   | Clean, repair or replace the non-return valve.                              |
|  |  |  | No              | b) The tank precharge pressure is not correct.  | Adjust the tank precharge pressure to 70 % of the required outlet pressure. |

## 13. Technical data

### 13.1 Operating conditions

|                              |                            |
|------------------------------|----------------------------|
| Maximum ambient temperature: |                            |
| 1 x 208-230 V, 60 Hz:        | 45 °C (113 °F)             |
| 1 x 115 V, 60 Hz:            | 45 °C (113 °F)             |
| 1 x 200-240 V, 50/60 Hz:     | 55 °C (131 °F)             |
| Maximum liquid temperature:  | 45 °C (113 °F)             |
| Maximum system pressure:     | 10 bar, 1 MPa (145 psi)    |
| Maximum inlet pressure:      | 6 bar, 0.6 MPa (87 psi)    |
| Maximum head:                | 45 m (147 ft)              |
| IP rating:                   | X4D (outdoor installation) |
| Pumped liquid:               | Clean water                |
| Noise level:                 | < 47-53 dB(A)              |

### 13.2 Mechanical data

Pipe connections are R 1" or NPT 1".

### 13.3 Electrical data

| Type   | Supply voltage [V] | Frequency [Hz] | I <sub>max.</sub> [A] | P1 [W] | Stand-by power [W] |
|--------|--------------------|----------------|-----------------------|--------|--------------------|
|        |                    |                |                       |        | 2                  |
| SCALA2 | 1 x 200-240        | 50/60          | 2.3 - 2.8             | 550    | 2                  |
| SCALA2 | 1 x 208-230        | 60             | 2.3 - 2.8             | 550    | 2                  |
| SCALA2 | 1 x 115            | 60             | 5 - 5.7               | 560    | 2                  |

| Type   | Supply voltage [V] | Frequency [Hz] | Plug                    |
|--------|--------------------|----------------|-------------------------|
|        |                    |                | IEC, type E&F           |
| SCALA2 | 1 x 200-240        | 50/60          | IEC, type I             |
|        |                    |                | IEC, type G             |
|        |                    |                | None                    |
| SCALA2 | 1 x 208-230        | 60             | NEMA 6-15P              |
| SCALA2 | 1 x 115            | 60             | IEC, type B, NEMA 5-15P |

#### 13.3.1 Dimensions and weights

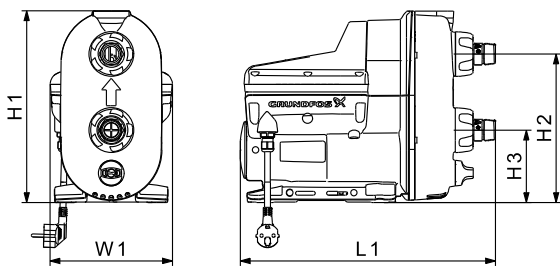

TMD06 3305 5114

| Type   | H1 [mm] [inch] | H2 [mm] [inch] | H3 [mm] [inch] | W1 [mm] [inch] | L1 [mm] [inch] | Weight [kg] [lbs] |
|--------|----------------|----------------|----------------|----------------|----------------|-------------------|
| SCALA2 | 302 [11.9]     | 234 [9.2]      | 114 [4.5]      | 193 [7.6]      | 403 [15.9]     | 10 [22]           |

## 14. Disposal

This product has been designed with focus on the disposal and recycling of materials. The following disposal values apply to all variants of Grundfos SCALA pumps:

- minimum 85 % for recycling
- maximum 10 % for incineration
- maximum 5 % for depositing.

Values are percent of total weight.

This product or parts of it must be disposed of in an environmentally sound way according to local regulations.

Subject to alterations.

**Argentina**

Bombas GRUNDFOS de Argentina S.A.  
Ruta Panamericana km. 37.500 Centro  
Industrial Garin  
1619 Garin Pcia. de B.A.  
Phone: +54-3327 414 444  
Telefax: +54-3327 45 3190

**Australia**

GRUNDFOS Pumps Pty. Ltd.  
P.O. Box 2040  
Regency Park  
South Australia 5942  
Phone: +61-8-8461-4611  
Telefax: +61-8-8340 0155

**Austria**

GRUNDFOS Pumpen Vertrieb Ges.m.b.H.  
Grundfosstraße 2  
A-5082 Grödig/Salzburg  
Tel.: +43-6246-883-0  
Telefax: +43-6246-883-30

**Belgium**

N.V. GRUNDFOS Bellux S.A.  
Boomssesteenweg 81-83  
B-2630 Aartselaar  
Tél.: +32-3-870 7300  
Télécopie: +32-3-870 7301

**Belarus**

Представительство ГРУНДФОС в  
Минске  
220125, Минск  
ул. Шафарьянская, 11, оф. 56, БЦ  
«Порт»  
Тел.: +7 (375 17) 286 39 72/73  
Факс: +7 (375 17) 286 39 71  
E-mail: minsk@grundfos.com

**Bosna and Herzegovina**

GRUNDFOS Sarajevo  
Zmaja od Bosne 7-7A,  
BH-71000 Sarajevo  
Phone: +387 33 592 480  
Telefax: +387 33 590 465  
www.ba.grundfos.com  
e-mail: grundfos@bih.net.ba

**Brazil**

BOMBAS GRUNDFOS DO BRASIL  
Av. Humberto de Alencar Castelo Branco,  
630  
CEP 09850 - 300  
São Bernardo do Campo - SP  
Phone: +55-11 4393 5533  
Telefax: +55-11 4343 5015

**Bulgaria**

Grundfos Bulgaria EOOD  
Slatina District  
Iztochna Tangenta street no. 100  
BG - 1592 Sofia  
Tel. +359 2 49 22 200  
Fax. +359 2 49 22 201  
email: bulgaria@grundfos.bg

**Canada**

GRUNDFOS Canada Inc.  
2941 Brighton Road  
Oakville, Ontario  
L6H 6C9  
Phone: +1-905 829 9533  
Telefax: +1-905 829 9512

**China**

GRUNDFOS Pumps (Shanghai) Co. Ltd.  
10F The Hub, No. 33 Suhong Road  
Minhang District  
Shanghai 201106  
PRC  
Phone: +86 21 612 252 22  
Telefax: +86 21 612 253 33

**Croatia**

GRUNDFOS CROATIA d.o.o.  
Buzinski prilaz 38, Buzin  
HR-10010 Zagreb  
Phone: +385 1 6595 400  
Telefax: +385 1 6595 499  
www.hr.grundfos.com

**Czech Republic**

GRUNDFOS s.r.o.  
Čajkovského 21  
779 00 Olomouc  
Phone: +420-585-716 111  
Telefax: +420-585-716 299

**Denmark**

GRUNDFOS DK A/S  
Martin Bachs Vej 3  
DK-8850 Bjerringbro  
Tlf.: +45-87 50 50 50  
Telefax: +45-87 50 51 51  
E-mail: info\_GDK@grundfos.com  
www.grundfos.com/DK

**Estonia**

GRUNDFOS Pumps Eesti OÜ  
Peterburi tee 92G  
11415 Tallinn  
Tel: + 372 606 1690  
Fax: + 372 606 1691

**Finland**

OY GRUNDFOS Pumput AB  
Trukkikuja 1  
FI-01360 Vantaa  
Phone: +358-(0) 207 889 500  
Telefax: +358-(0) 207 889 550

**France**

Pompes GRUNDFOS Distribution S.A.  
Parc d'Activités de Chesnes  
57, rue de Malacombe  
F-38290 St. Quentin Fallavier (Lyon)  
Tél.: +33-4 74 82 15 15  
Télécopie: +33-4 74 94 10 51

**Germany**

GRUNDFOS GMBH  
Schlüterstr. 33  
40699 Erkrath  
Tel.: +49-(0) 211 929 69-0  
Telefax: +49-(0) 211 929 69-3799  
e-mail: infoservice@grundfos.de  
Service in Deutschland:  
e-mail: kundendienst@grundfos.de

**Greece**

GRUNDFOS Hellas A.E.B.E.  
20th km. Athinon-Markopoulou Av.  
P.O. Box 71  
GR-19002 Peania  
Phone: +0030-210-66 83 400  
Telefax: +0030-210-66 46 273

**Hong Kong**

GRUNDFOS Pumps (Hong Kong) Ltd.  
Unit 1, Ground floor  
Siu Wai Industrial Centre  
29-33 Wing Hong Street &  
68 King Lam Street, Cheung Sha Wan  
Kowloon  
Phone: +852-27861706 / 27861741  
Telefax: +852-27858664

**Hungary**

GRUNDFOS Hungária Kft.  
Park u. 8  
H-2045 Törökbálint,  
Phone: +36-23 511 110  
Telefax: +36-23 511 111

**India**

GRUNDFOS Pumps India Private Limited  
118 Old Mahabalipuram Road  
Thoraiakkam  
Chennai 600 096  
Phone: +91-44 2496 6800

**Indonesia**

PT. GRUNDFOS POMPA  
Graha Intirub Lt. 2 & 3  
Jin. Cililitan Besar No.454. Makasar,  
Jakarta Timur  
ID-Jakarta 13650  
Phone: +62 21-469-51900  
Telefax: +62 21-460 6910 / 460 6901

**Ireland**

GRUNDFOS (Ireland) Ltd.  
Unit A, Merrywell Business Park  
Ballymount Road Lower  
Dublin 12  
Phone: +353-1-4089 800  
Telefax: +353-1-4089 830

**Italy**

GRUNDFOS Pompe Italia S.r.l.  
Via Gran Sasso 4  
I-20060 Truccazzano (Milano)  
Tel.: +39-02-95838112  
Telefax: +39-02-95309290 / 95838461

**Japan**

GRUNDFOS Pumps K.K.  
Gotanda Metalion Bldg., 5F,  
5-21-15, Higashi-gotanda  
Shiagawa-ku, Tokyo  
141-0022 Japan  
Phone: +81 35 448 1391  
Telefax: +81 35 448 9619

**Korea**

GRUNDFOS Pumps Korea Ltd.  
6th Floor, Aju Building 679-5  
Yeoksam-dong, Kangnam-ku, 135-916  
Seoul, Korea  
Phone: +82-2-5317 600  
Telefax: +82-2-5633 725

**Latvia**

SIA GRUNDFOS Pumps Latvia  
Deglava biznesa centrs  
Augusta Deglava ielā 60, LV-1035, Rīga,  
Tālr.: + 371 714 9640, 7 149 641  
Fakss: + 371 914 9646

**Lithuania**

GRUNDFOS Pumps UAB  
Smolensko g. 6  
LT-03201 Vilnius  
Tel: + 370 52 395 430  
Fax: + 370 52 395 431

**Malaysia**

GRUNDFOS Pumps Sdn. Bhd.  
7 Jalan Peguam U1/25  
Glenmarie Industrial Park  
40150 Shah Alam  
Selangor  
Phone: +60-3-5569 2922  
Telefax: +60-3-5569 2866

**Mexico**

Bombas GRUNDFOS de México S.A. de  
C.V.  
Boulevard TLC No. 15  
Parque Industrial Stiva Aeropuerto  
Apodaca, N.L. 66600  
Phone: +52-81-8144 4000  
Telefax: +52-81-8144 4010

**Netherlands**

GRUNDFOS Netherlands  
Veluwezoom 35  
1302 CA ALMERE  
Tel.: +31-88-478 6336  
Telefax: +31-88-478 6332  
E-mail: info\_gnl@grundfos.com

**New Zealand**

GRUNDFOS Pumps NZ Ltd.  
17 Beatrice Tinsley Crescent  
North Harbour Industrial Estate  
Albany, Auckland  
Phone: +64-9-415 3240  
Telefax: +64-9-415 3250

**Norway**

GRUNDFOS Pumper A/S  
Strømsveien 344  
Postboks 235, Leirdal  
N-1011 Oslo  
Tlf.: +47-22 90 47 00  
Telefax: +47-22 32 21 50

**Poland**

GRUNDFOS Pompy Sp. z o.o.  
ul. Klonowa 23  
Baranowo k. Poznania  
PL-62-081 Przeźmierowo  
Tel: (+48-61) 650 13 00  
Fax: (+48-61) 650 13 50

**Portugal**

Bombas GRUNDFOS Portugal, S.A.  
Rua Calvet de Magalhães, 241  
Apartado 1079  
P-2770-153 Paço de Arcos  
Tel.: +351-21-440 76 00  
Telefax: +351-21-440 76 90

**Romania**

GRUNDFOS Pompe România SRL  
Bd. Biruintei, nr 103  
Pantelimon county Ilfov  
Phone: +40 21 200 4100  
Telefax: +40 21 200 4101  
E-mail: romania@grundfos.ro

**Russia**

ООО Грундфос Россия  
109544, г. Москва, ул. Школьная, 39-41,  
стр. 1  
Тел. (+7) 495 564-88-00 (495) 737-30-00  
Факс (+7) 495 564 88 11  
E-mail grundfos.moscow@grundfos.com

**Serbia**

Grundfos Srbija d.o.o.  
Omladinskih brigada 90b  
11070 Novi Beograd  
Phone: +381 11 2258 740  
Telefax: +381 11 2281 769  
www.rs.grundfos.com

**Singapore**

GRUNDFOS (Singapore) Pte. Ltd.  
25 Jalan Tukang  
Singapore 619264  
Phone: +65-6681 9688  
Telefax: +65-6681 9689

**Slovakia**

GRUNDFOS s.r.o.  
Prievozská 4D  
821 09 BRATISLAVA  
Phona: +421 2 5020 1426  
sk.grundfos.com

**Slovenia**

GRUNDFOS LJUBLJANA, d.o.o.  
Leskoškova 9e, 1122 Ljubljana  
Phone: +386 (0) 1 568 06 10  
Telefax: +386 (0)1 568 06 19  
E-mail: tehnika-si@grundfos.com

**South Africa**

GRUNDFOS (PTY) LTD  
Corner Mountjoy and George Allen Roads  
Wilbart Ext. 2  
Bedfordview 2008  
Phone: (+27) 11 579 4800  
Fax: (+27) 11 455 6066  
E-mail: lsmart@grundfos.com

**Spain**

Bombas GRUNDFOS España S.A.  
Camino de la Fuentesilla, s/n  
E-28110 Algete (Madrid)  
Tel.: +34-91-848 8800  
Telefax: +34-91-628 0465

**Sweden**

GRUNDFOS AB  
Box 333 (Lunnagårdsgatan 6)  
431 24 Mölndal  
Tel.: +46 31 332 23 000  
Telefax: +46 31 331 94 60

**Switzerland**

GRUNDFOS Pumpen AG  
Bruggacherstrasse 10  
CH-8117 Fällanden/ZH  
Tel.: +41-44-806 8111  
Telefax: +41-44-806 8115

**Taiwan**

GRUNDFOS Pumps (Taiwan) Ltd.  
7 Floor, 219 Min-Chuan Road  
Taichung, Taiwan, R.O.C.  
Phone: +886-4-2305 0868  
Telefax: +886-4-2305 0878

**Thailand**

GRUNDFOS (Thailand) Ltd.  
92 Chaloen Phrakiat Rama 9 Road,  
Dokmai, Pravej, Bangkok 10250  
Phone: +66-2-725 8999  
Telefax: +66-2-725 8998

**Turkey**

GRUNDFOS POMPA San. ve Tic. Ltd. Sti.  
Gezbe Organize Sanayi Bölgesi  
Ihsan dede Caddesi,  
2. yol 200. Sokak No. 204  
41490 Gezbe/ Kocaeli  
Phone: +90 - 262-679 7979  
Telefax: +90 - 262-679 7905  
E-mail: satis@grundfos.com

**Ukraine**

Бізнес Центр Європа  
Столичне шосе, 103  
м. Київ, 03131, Україна  
Телефон: (+38 044) 237 04 00  
Факс: (+38 044) 237 04 01  
E-mail: ukraine@grundfos.com

**United Arab Emirates**

GRUNDFOS Gulf Distribution  
P.O. Box 16768  
Jebel Ali Free Zone  
Dubai  
Phone: +971 4 8815 166  
Telefax: +971 4 8815 136

**United Kingdom**

GRUNDFOS Pumps Ltd.  
Grovebury Road  
Leighton Buzzard/Beds. LU7 4TL  
Phone: +44-1525-850000  
Telefax: +44-1525-850011

**U.S.A.**

GRUNDFOS Pumps Corporation  
17100 West 118th Terrace  
Olathe, Kansas 66061  
Phone: +1-913-227-3400  
Telefax: +1-913-227-3500

**Uzbekistan**

Grundfos Tashkent, Uzbekistan The  
Representative Office of Grundfos  
Kazakhstan in Uzbekistan  
38a, Oybek street, Tashkent  
Телефон: (+998) 71 150 3290 / 71 150  
3291  
Факс: (+998) 71 150 3292

Addresses Revised 25.01.2016

|                      |
|----------------------|
| <b>98880508</b> 0516 |
|----------------------|

|              |
|--------------|
| ECM: 1165354 |
|--------------|