

# *Greenway*<sup>®</sup> Water Technologies

## **Advance Cabinet Series Softeners**



Installation Instructions & Owner's Manual

# TABLE OF CONTENTS:

<b>Preinstallation Instructions for Dealers</b>	<b>Page</b>	<b>1</b>
<b>Bypass Valve</b>	<b>Page</b>	<b>1-2</b>
<b>Installation Instructions</b>	<b>Page</b>	<b>3-4</b>
<b>Programming Procedures for Water Softeners</b>	<b>Page</b>	<b>5-6</b>
<b>Operating Displays for the Softener</b>	<b>Page</b>	<b>6-7</b>
<b>Start-up Instructions</b>	<b>Page</b>	<b>7-9</b>
<b>Specifications</b>	<b>Page</b>	<b>9</b>
<b>Troubleshooting Guide</b>	<b>Page</b>	<b>10-11</b>
<b>Replacement Parts</b>	<b>Page</b>	<b>12-17</b>
<b>Quick Reference Guide</b>	<b>Page</b>	<b>Back Cover</b>

## Your Water Test

Hardness	_____	gpg
Iron	_____	ppm
pH	_____	number
*Nitrates	_____	ppm
Manganese	_____	ppm
Sulphur	_____	yes/no
Total Dissolved Solids	_____	

\*Over 10ppm may be harmful for human consumption. Water conditioners do not remove nitrates or coliform bacteria, this requires specialized equipment.

Greenway Water Conditioners are precision built, high quality products. These units will deliver conditioned water for many years to come, when installed and operated properly. Please study this manual carefully and understand the cautions and notes before installing. This manual should be kept for future reference. If you have any questions regarding your water conditioner, contact your local dealer or Greenway Water Technologies at the following:

400 Southgate Dr. Guelph, Ontario, Canada  
•Phone: 1-888-5-WATER-0 •Fax: 519-837-8913

## PREINSTALLATION INSTRUCTIONS:

The manufacturer has set the water treatment unit's sequence of cycles, cycle times, salt dose, exchange capacity, and gallon capacity. For water softeners the salt dose refill time has been preset.

*The dealer should read this page and guide the installer regarding hardness, day override, and time of regeneration, before installation:*

*For the installer, the following must be used:*

- Set Installer Settings ... Hardness, Day Override (preset to 12 days), and Time of Regeneration (preset to 2:00 a.m.)
- Read *NORMAL OPERATING DISPLAYS*
- Set *TIME OF DAY*
- Read *POWER LOSS & ERROR DISPLAY*

*For the homeowner, please read operating instructions and displays.*

### **Water Softeners:**

During operation, the normal user displays are *TIME OF DAY* or *GALLONS REMAINING* before regeneration will occur.

*DAYS REMAINING* is an optional display but is not normally used. Each of these can be viewed by pressing *NEXT* to scroll through them. When stepping through any displays or programming, if no buttons are pressed within 5-minutes, the display returns to a normal user display. Any changes made prior to the 5 minute time out are incorporated.

To quickly exit any Programming, Installer Settings, etc., press *SET CLOCK*. Any changes made prior to the exit are incorporated. If desired, two regenerations within 24 hours are possible with a return to the preset program. To do a *double regeneration*:

1. Press the *REGEN* button once. *REGEN TODAY* will flash on the display.
2. Press and hold the *REGEN* button for 3 seconds until a regeneration begins.

Once the valve has completed the immediate regeneration, the valve will regenerate one more time at the preset.

### **BYPASS VALVE:**

The bypass valve is typically used to isolate the control valve from the plumbing system's water pressure in order to perform control valve repairs or maintenance. The 1" full flow bypass valve incorporates 4 positions including a diagnostic position that allows a service technician to have pressure to test a system while providing untreated bypass water to the building.

Be sure to install bypass valve onto main control valve, before beginning plumbing. Or, make provisions in the plumbing system for a bypass.

The bypass body and rotors are glass filled Noryl® and the nuts and caps are glass filled polypropylene. All seals are self-lubricating EPDM to help prevent valve seizing after long periods of non-use. Internal "O" Rings can easily be replaced if service is required.

The bypass consists of two interchangeable plug valves that are operated independently by red arrow shaped handles. The handles identify the direction of flow. The plug valves enable the bypass valve to operate in 4 positions.

1. **Normal Operation Position:** The inlet and outlet handles point in the direction of flow indicated by the engraved arrows on the control valve. Water flows through the control valve for normal operation of a water softener or filter. During the regeneration cycle this position provides regeneration water to the unit, while also providing untreated water to the distribution system (**Fig. 1**).
2. **Bypass Position:** The inlet and outlet handles point to the center of the bypass. The system is isolated from the water pressure in the plumbing system. Untreated water is supplied to the building (**Fig. 2**).
3. **Diagnostic Position:** The inlet handle points toward the control valve and the outlet handle points to the center of bypass valve. Untreated supply water is allowed to flow to the system and to the building, while not allowing water to exit from the system to the building (**Fig. 3**). This allows the service technician to draw brine and perform other tests without the test water going to the building.  
**NOTE:** The system must be rinsed before returning the bypass valve to the normal position.
4. **Shut Off Position:** The inlet handle points to the center of the bypass valve and the outlet handle points away from the control valve. The water is shut off to the building. The water treatment system will depressurize upon opening a tap in the building. A negative pressure in the building combined with the softener being in regeneration could cause a siphoning of brine into the building. If water is available on the outlet side of the softener or filter, it is an indication of water bypassing the system (**Fig. 4**) (i.e. a plumbing cross-connection somewhere in the building).

### NORMAL OPERATION POSITION

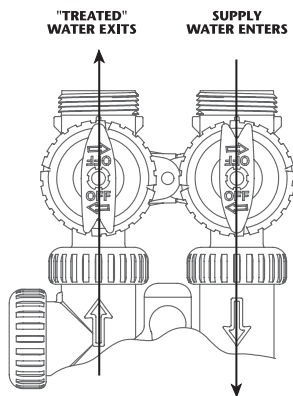

Figure 1

### BYPASS POSITION

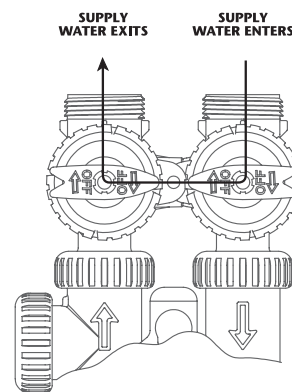

Figure 2

### DIAGNOSTIC POSITION

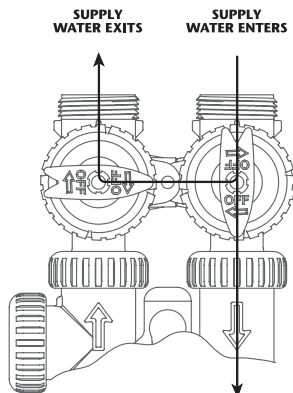

Figure 3

### SHUT OFF POSITION

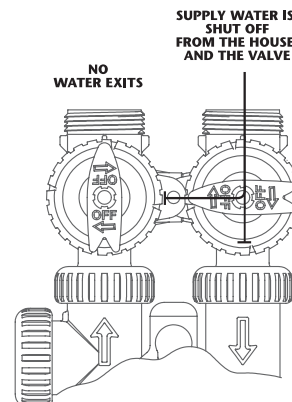

Figure 4

# INSTALLATION INSTRUCTIONS:

## GENERAL INSTALLATION & SERVICE WARNINGS

The control valve, fittings and/or bypass are designed to accommodate minor plumbing misalignments. There is a small amount of "give" to properly connect the piping but the water softener is not designed to support the weight of the plumbing.

Do not use Vaseline, oils, other hydrocarbon lubricants or spray silicone anywhere. A silicone lubricant may be used on black "O" Rings, but is not necessary. *Avoid any type of lubricants, including silicone, on red or clear lip seals.*

*Do not use pipe dope or other sealants on threads.* Teflon® tape must be used on the threads of the 1" NPT inlet and outlet, the brine line connection at the control valve, and on the threads for the drain line connection. Teflon® tape is not used on the nut connections or caps because "O" Ring seals are used. The nuts and caps are designed to be unscrewed or tightened by hand or with the special plastic Service Wrench, YY.WS.CV3193 (see page 7). If necessary pliers can be used to unscrew the nut or cap. Do not use a pipe wrench to tighten nuts or caps. *Do not place screwdriver in slots on caps and/or tap with a hammer.*

## SITE REQUIREMENTS

- water pressure – 30 - 100 psi
- water temperature – 33 - 100°F (0.5-37.7°C)
- electrical – 110 - 50/60Hz uninterrupted outlet
- the tank should be on a firm level surface
- current draw is 0.5 amperes
- the plug-in transformer is for dry locations only

## WELL WATER INSTALLATION

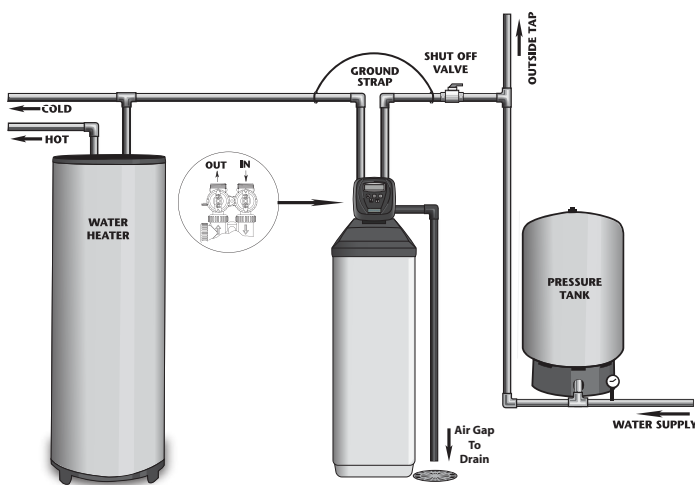

## MUNICIPAL INSTALLATION

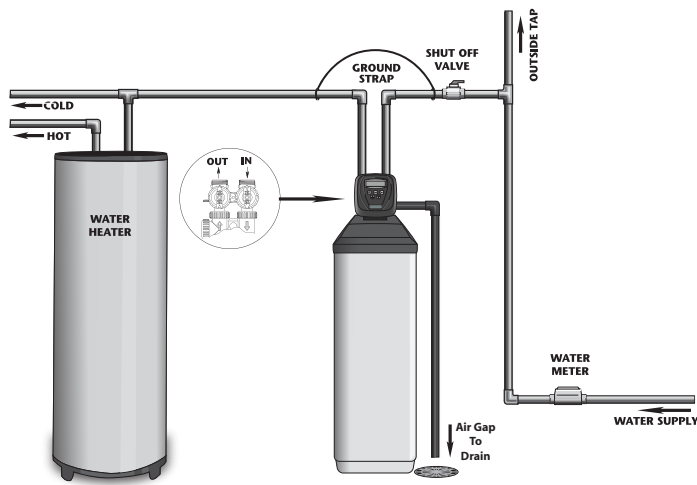

Waste connections or drain outlets shall be designed and constructed to provide for connection to the sanitary waste system through an air gap of 2 pipe diameters or 25 mm (1 in), whichever is larger.

1. The distance between the drain and the water conditioner should be as short as possible.
2. Since salt must be periodically added to the brine tank, it should be located where it is easily accessible.
3. Do not install any water conditioner with less than 10 feet of piping between its outlet and the inlet of a water heater.
4. Do not locate unit where it or its connections (including the drain and overflow lines) will ever be subjected to room temperatures under 33° F.

5. **INLET/OUTLET PLUMBING:** Be sure to install Bypass Valve onto main control valve before beginning plumbing. Make provisions to bypass outside hydrant and cold hard water lines at this time. Install an inlet shutoff valve and plumb to the unit's bypass valve inlet located at the right rear as you face the unit. There are a variety of installation fittings available. They are listed under Installation Fitting Assemblies, page 17. When assembling the installation fitting package (inlet and outlet), connect the fitting to the plumbing system first and then attach the nut, split ring and "O" Ring. Heat from soldering or solvent cements may damage the nut, split ring or "O" Ring. Solder joints should be cool and solvent cements should be set before installing the nut, split ring and "O" Ring. Avoid getting solder flux, primer, and solvent cement on any part of the "O" Rings, split rings, bypass valve or control valve. If the building's electrical system is grounded to the plumbing, install a copper grounding strap from the inlet to the outlet pipe. Plumbing must be done in accordance with all applicable local codes.
  
6. **DRAIN LINE:** First, be sure that the drain can handle the backwash rate of the system. Solder joints near the drain must be done prior to connecting the drain line flow control fitting. Leave at least 6" between the drain line flow control fitting and solder joints. Failure to do this could cause interior damage to the flow control. Install a 1/2" I.D. flexible plastic tube to the Drain Line Assembly or discard the tubing nut and use the 3/4" NPT fitting for rigid pipe (recommended). Where the drain line is elevated but empties into a drain below the level of the control valve, form a 7" loop at the discharge end of the line so that the bottom of the loop is level with the drain connection on the control valve. This will provide an adequate anti-siphon trap. Where the drain empties into an overhead sewer line, a sink-type trap must be used. Run drain tube to its discharge point in accordance with plumbing codes. Pay special attention to codes for air gaps and anti-siphon devices.
  
7. **BRINE TANK CONNECTION:** Install the 3/8" O.D. polyethylene tube from the Refill Elbow to the Brine Valve in the brine tank.
  
8. **OVERFLOW LINE CONNECTION:**  
*An overflow drain line is recommended where a brine overflow could damage furnishings or the building structure. Your softener is equipped with a brine tank safety float which greatly reduces the chance of an accidental brine overflow. In the event of a malfunction, however, an overflow line connection will direct the "overflow" to the drain instead of spilling on the floor where it could cause considerable damage. This fitting is an elbow on the side of the brine tank. Attach a length of 1/2" I.D. tubing to fitting and run to drain. Do not elevate overflow line higher than 3" below bottom of overflow fitting. Do not "tie" this tube into the drain line of the control valve. Overflow line must be a direct, separate line from overflow fitting to drain, sewer, or tub. Allow an air gap as per the drain line instructions.*



**CAUTION: Never insert a drain line into a drain, sewer line, or trap. Always allow an air gap between the drain line and the wastewater to prevent the possibility of sewage being back-siphoned into the conditioner.**

Waste connections or drain outlets shall be designed and constructed to provide for connection to the sanitary waste system through an air gap of 2 pipe diameters or 25 mm (1 in), whichever is larger.

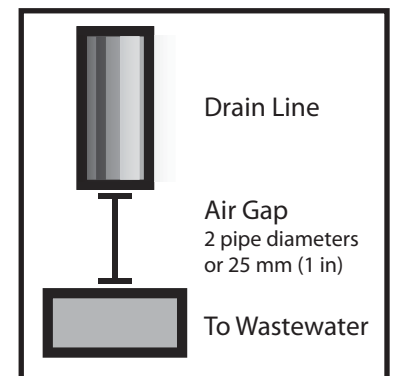

# PROGRAMMING PROCEDURES FOR WATER SOFTENERS:

## 1. Set time of day:

Time of day should only need to be set after extended power outages or when daylight saving time begins or ends. If an extended power outage occurs, the time of day will flash on and off indicating that the time should be reset.

**STEP 1** – Press SET CLOCK.

**STEP 2** – Current Time (hour): Set the hour of the day using the ▲ or ▼ buttons. AM/PM toggles after 12:00. Press **NEXT** to go to step 3.

**STEP 3** – Current Time (minutes): Set the minutes of the day using the ▲ or ▼ buttons. Press **NEXT** to exit Set Clock.

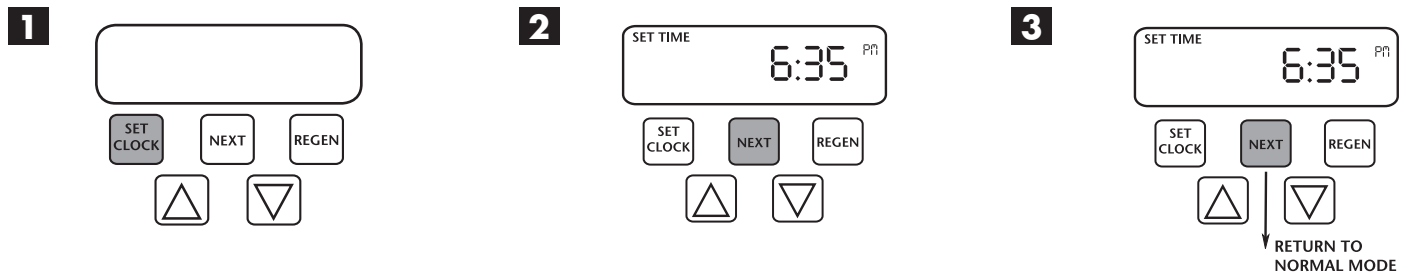

## 2. Programming:

### Installer Displays/Settings

**STEP 1** – Press **NEXT** and ▲ simultaneously for 3 seconds.

**STEP 2** – *Hardness:* Set the amount of hardness in grains of hardness as calcium carbonate per gallon using the ▲ or ▼ buttons. The default is 20 with value ranges from 1 to 150 in 1 grain increments.

**Note:** The grains per gallon can be increased if soluble iron needs to be reduced. Press **NEXT** to go to step 3.

**STEP 3** – *Day Override:* When gallon capacity is set to off, sets the number of days between regenerations. When gallon capacity is set to AUTO or to a number, sets the maximum number of days between regenerations. If value is set to OFF regeneration initiation is based solely on gallons used. If value is set as a number (allowable range from 1 to 28) a regeneration initiation will be called for on that day even if sufficient number of gallons were not used to call for regeneration. Set Day Override using ▲ or ▼ buttons: Press **NEXT** to go to step 4.

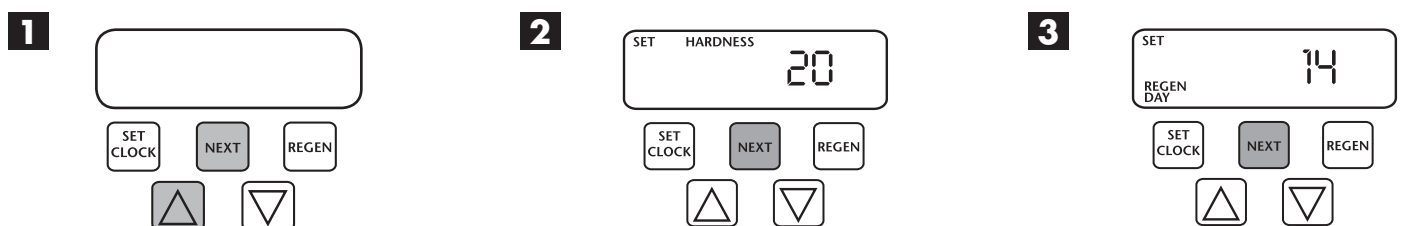

## 2. Programming cont'd:

**STEP 4** – *Regeneration Time (Hour)*: Set the hour of day for regeneration using the ▲ or ▼ buttons. AM/PM toggles after 12:00. The default time is 2:00 a.m.

Press NEXT to go to step 5.

**STEP 5** – Next *Regeneration Time (Minutes)*: Set the minutes of day for regeneration using the ▲ or ▼ buttons. Press NEXT to exit Installer Displays/Settings.

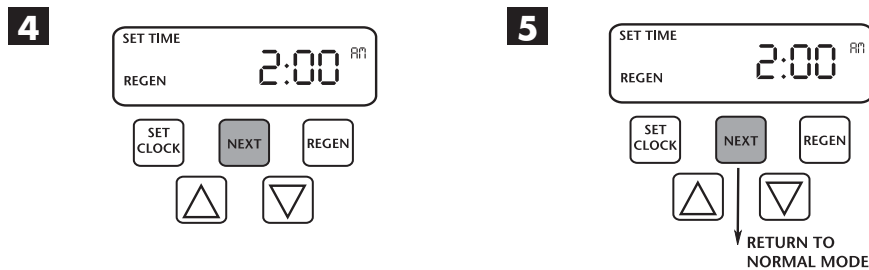

## OPERATING DISPLAYS FOR THE SOFTENER:

1. **General Operation:** When the system is operating one of two displays will be shown. Pressing NEXT will alternate between the displays. One of the displays is always the current time of day. The second display is one of the following: days remaining or gallons remaining. Days remaining are the number of days left before the system goes through a regeneration cycle. Capacity remaining is the number of gallons that will be treated before the system goes through a regeneration cycle. The user can scroll between the displays as desired. If the system has called for a regeneration that will occur at the preset time of regeneration, the words REGEN TODAY will appear on the display. When water is being treated (i.e. water is flowing through the system) the word SOFTENING flashes on the display if a water meter is installed.

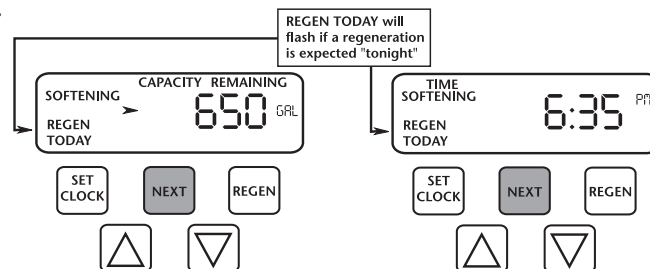

2. **Regeneration Mode:** Typically a system is set to regenerate at a time of no water use. If there is a demand for water when the system is regenerating, untreated water will be delivered. When the system begins to regenerate, the display will change to include information about the step of the regeneration process and the time remaining for that step to be completed. The system runs through the steps automatically and will reset itself to provide treated water when the regeneration has been completed.



3. **Manual Regeneration:** Sometimes there is a need to regenerate the system sooner than when the system calls for it, usually referred to as manual regeneration. There may be a period of heavy water usage because of guests or a heavy laundry day.

To initiate a manual regeneration immediately, press and hold the REGEN button for three seconds. The system will begin to regenerate immediately. The control valve may be stepped through the various regeneration cycles by pressing the REGEN button.

To initiate a manual regeneration at the preset delayed regeneration time, when the regeneration time option is set to NORMAL or NORMAL + ON 0, press and release REGEN. The words REGEN TODAY will flash on the display to indicate that the system will regenerate at the preset delayed regeneration time. If you pressed the REGEN button in error, pressing the button again will cancel the request.



Once a manual regeneration is initiated, the unit will go into the FILL position. This position allows water to enter the brine tank until it reaches the proper level. Once this position is complete, you will notice a 240 Minute (4 hours) SOFTENING position. This 4-hour window allows the salt to dissolve and achieve proper brine strength. During these FILL and SOFTENING positions, you will have softened water available for use. Once the unit advances to the BACKWASH position and subsequent positions thereafter (see Start Up Instructions for regeneration sequence), the water softener will deliver water, but it will be untreated.

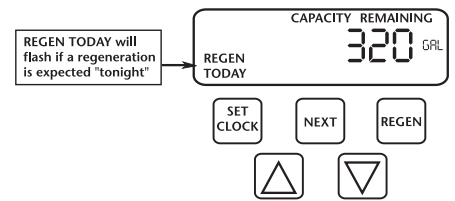

**IMPORTANT:** With the Dry Salt Storage Feature, the brine tank will refill 4 hours before the actual regeneration occurs. You may experience a small amount of noise for a short period of time at 10:00 p.m. (with typical setting) on the night that regeneration is to occur. This noise is only the brine tank filling and at no time during this process will you be without treated water.

4. **Power Loss:** If the power goes out for less than two hours, the system will automatically reset itself. If an extended power outage occurs, the time of day will flash on and off which indicates the time of day should be reset. *The system will remember all other settings.*

5. **Error Message:** If the word *ERROR* and a number are alternately flashing on the display record the number and contact the dealer for help. This indicates that the valve was not able to function properly.

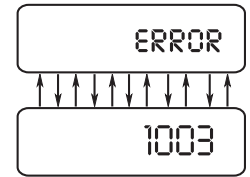

6. **Brine Tank Maintenance and Salt:** Refill the brine tank as necessary, making sure at least 1/3 of the brine tank is full at all times. Without proper salt levels, the water softener may not operate properly. Because "typical" settings of this water softener include a dry salt storage feature (no water in brine tank between regeneration), the manufacturer recommends the use of solar salt for best results. The brine tank is manufactured for the use of solar, pellets or rock salt. If pellet or rock salt is used, a cleaning of the brine tank every six months is recommended. If the dry salt storage feature is not being utilized, block salt may be used.

**CAUTION:** The manufacturer does not recommend the use of any resin cleaners, nor placement of any resin cleaners into the brine tank. This may be harmful to the water softener and for human consumption. Consult dealer for proper cleaning instructions.

## START-UP INSTRUCTIONS FOR WATER SOFTENERS:

- After installation is complete, rotate bypass handles to bypass mode (**see Fig. 2 on page 2**).
- Turn on water and check for leaks.
- Fully open a cold water faucet — preferably a laundry sink or bathtub with no aerator.
- Allow water to run until clear to rid pipes of debris which may have occurred during installation.

**NOTE:** The system regeneration sequence for softeners is in one of the two following sequences. (If it is desired to change this sequence, please refer to the Dealer Manual or contact the manufacturer.)

### Brine (Regenerant) Post Fill

- Backwash
- Regenerate (Brine)
- Second Backwash\*
- Rinse
- Fill
- Service

### Brine (Regenerant) Pre Fill

- Fill
- Softening
- Backwash
- Regenerate (Brine)
- Second Backwash
- Rinse
- Service

\* Optional

The system is now ready for filling with water. For the purpose of filling the softener, leave the unit in the bypass position until the 4th step, then repeat steps 1-6 with the unit full. **Do not open the bypass at this time**, it will be filled in the backwash position. Once the unit is filled with water (step 2) then open the bypass.

## START-UP INSTRUCTIONS FOR WATER SOFTENERS:

1. With the softener in the bypass mode (**Fig. 2 on page 2**) and the control valve in normal operation where the display shows either the time of day or the gallons remaining:  
Manually add 3 GALLONS of water to the regenerant tank.  
**NOTE:** If too much water is put into the brine tank during softener start up it could result in a salty water complaint after the first regeneration.  
During the first regeneration the unit will draw out the initial volume of brine/regenerant and refill it with the correct preset amount.
  2. Press and hold the *REGEN* button until the motor starts (3 seconds). Release button. The display will either read *BACKWASH* or *FILL* and the remaining time in this step is counting down. If *BACKWASH* is shown in window, proceed to step 2b.
    - 2a. If the unit display is *FILL*, check to verify that the regenerant tank is filling at a rate of 1/2 gallon per minute. Check Brine line connections for leaks. Press *REGEN* button and unit will proceed to the *SOFTENING* position. During a normal regeneration this will be a 4 hour period for salt to dissolve. Press *REGEN* again to put valve in *BACKWASH*. Proceed to 2b.
    - 2b. Unplug the transformer so that the valve will not cycle to the next position. Open the inlet handle of the bypass valve **very slightly** allowing water to fill the tank **slowly** in order to expel air. Once air is expelled and water is running at drain, open inlet to control and place into the diagnostic mode (**Fig. 3 on page 2**).
-  **CAUTION: If water flows too rapidly, it could result in loss of media to the drain. When the water is flowing steadily to the drain without the presence of air, slowly open the inlet valve. Check drain that it can receive the flow of water. Restore power.**
3. Press *REGEN* button again to put the valve into *BRINE* position. Check the brine line for suction (after unit is full). Verify that water is being drawn from regenerant tank with no air leaks or bubbles in the brine line. There should be a slow flow to the drain.
  4. Press *REGEN* button again and place unit into a second *BACKWASH* position. Water will flow steadily at the drain. Check for the presence of air. Again, check drain that it can receive the flow of water.
  5. Press *REGEN* button and place unit into rinse position. Check drain line to be secure and that drain can receive the flow of water. There should be a rapid flow to the drain. Unplug transformer to keep the valve in the *RINSE* position. Allow to run until steady, clear and without air. While the unit is rinsing, load the brine tank with water softener salt.
  6. Press the *REGEN* button.
    - 6a. For units that "Pre Fill" the brine tank, the valve will cycle back to the normal operating position. Advance to Step 8.
    - 6b. For units that "Post Fill," the unit is now in the *FILL* position. Check to verify that the regenerant tank is filling at a rate of 1/2 gallon per minute. Check Brine line connections for leaks. Proceed to Step 7.
  7. Press *REGEN* button again. Valve will cycle back to the normal operating position with the time of day or gallons remaining displayed.

# START-UP INSTRUCTIONS FOR WATER SOFTENERS:

8. Repeat steps 1 - 7 and now check the various cycles for proper operation.
9. Once the cycle operation has been verified, Place bypass valve in the normal operating mode **(Fig. 1 on page 2)** by opening the outlet bypass handle.
10. Go to laundry tub or bathtub faucet, preferably a faucet without an aerator and turn on the cold water, let the water run. Note the color of water coming from faucet. If discolored let water run until clear.

**NOTE:** At no time should there be “large particles” of media noticed at faucet or laundry tub. If this is seen immediately shut off water and bypass system as this could be an indication of a distributor failure. Contact manufacturer or distributor for assistance.

## SPECIFICATIONS:

Model		GACS835	GACS1035
Capacity: (Grains/Lbs. NaCl)	Maximum	21,000 @ 9.0	32,000 @ 15.0
	Medium	18,000 @ 6.0	28,400 @ 9.0
	Minimum	13,600 @ 3.0	23,600 @ 6.0
Amount of Media (Cu. Ft.)		0.66	1.0
Maximum Water Hardness (GPG)		50	75
<sup>2</sup> Maximum Iron (PPM)		1	1
<sup>3</sup> Minimum pH Required		7	7
<sup>4</sup> Peak Flow Rate (GPM @ PSI)		12.2 @ 15.0	17.1 @ 15.0
Continuous Flow Rate (GPM @ PSI)		5.8 @ 5.0	5.0 @ 2.8
Water Pressure Range (PSI)		30 - 100	30 - 100
Operating Temperature Range (°F)		33 - 100	33 - 100
Electrical Requirements (volts-hertz)		110 - 50/60	110 - 50/60
Pipe Size		1"	1"
Total Dimensions:	Media Tank	13.5"(w) x 42.5"(h)	13.5"(w) x 42.5"(h)
	Depth	22.5"	22.5"

<sup>1</sup> All GPWS Series units are factory set for Medium Salt Setting. Note: influent waters must be at least 3 GPG hardness and 80 TDS. A calcite or corsex unit may be needed for correct operation.

<sup>2</sup> Iron removal may vary depending on form of iron, pH and other local conditions. On waters that are pre-chlorinated or where other pre-oxidation occurs, an iron precipitate can form that is too small to be filtered.

<sup>3</sup> The pH listed is the minimum for the influent water.

<sup>4</sup> Unit not tested for capacity at these flow rates. Water quality may vary.

Model	GACS835		GACS1035	
	Min.	Gal.	Min.	Gal.
Brine Refill	3:51	2	5:51	3
Backwash	6	10	8	22
Brine & Rinse	40	16	60	24
Rapid Rinse	4	7	4	11
Total	54	35	78	60

<b>PROBLEM</b>	<b>CAUSE</b>	<b>CORRECTION</b>
<b>1. Timer does not display time of day</b>	A. transformer unplugged	A. reconnect transformer
	B. no power at outlet	B. repair or use working outlet
	C. defective transformer	C. replace transformer
	D. defective PC board	D. replace PC board
<b>2. Timer does not display correct time of day</b>	A. outlet is on a switch	A. use unswitched outlet
	B. power outage	B. reset time of day
	C. defective PC board	C. replace PC board
<b>3. No softening/ filtering display when water is flowing</b>	A. bypass valve in bypass position	A. put bypass in service position
	B. meter cable disconnected	B. reconnect PC board
	C. restricted/stalled meter turbine	C. remove meter and check for debris
	D. defective meter	D. replace meter
	E. defective PC board	E. replace PC board
<b>4. Unit regenerates at wrong time of day</b>	A. past power outage	A. reset time of day
	B. incorrect time of day displayed	B. reset time of day
	C. time of regenerant set incorrectly	C. reset time of regeneration
	D. control set at "on 0"	D. check with regeneration time option in programming
	E. control set at "NORMAL + on 0"	E. check with regeneration time option in programming
<b>5. "Error" followed by code #</b>  <ul style="list-style-type: none"> <li>• "Error" code 1001- unable to recognize start of regeneration</li> <li>• "Error" code 1002-unexpected stall</li> <li>• "Error" code 1003-motor ran too long</li> <li>• Timed out trying to reach next cycle position</li> <li>• If other codes appear contact factory</li> </ul>	A. valve has just been serviced (#1001)	A. press <b>NEXT</b> and <b>REGEN</b> for 3 secs. or momentarily unplug power source from PC board
	B. foreign material stuck in valve (#1002)	B. check piston and spacer stack for obstruction
	C. excessive piston resistance (#1002)	C. replace piston(s) and spacer stack assy
	D. piston not in home position (#1004)	D. press <b>NEXT</b> and <b>REGEN</b> or momentarily unplug PC board power
	E. motor gears not fully engaged - motor wires broken - failed motor (#1001)	E. check motor wiring
	F. center drive gear reflector dirty or damaged - missing or broken gear (#1004)	F. replace or clean drive gear(s)
	G. drive bracket incorrectly aligned on backplate (#1004)	G. reset drive bracket
	H. PC board is damaged or defective (#1009, 2001, 4002, 4003, 4004, 4010)	H. replace PC board
	I. PC board incorrectly aligned on drive bracket (#1009, 2001, 4002, 4003, 4004, 4010)	I. reset PC board onto drive bracket

<b>PROBLEM</b>	<b>CAUSE</b>	<b>CORRECTION</b>
<b>6. Valve stalled in regeneration</b>	A. motor not operating	A. replace motors
	B. no power at outlet	B. repair outlet or use working outlet
	C. defective transformer	C. replace transformer
	D. defective PC board	D. replace PC board
	E. broken drive gear or drive cap assy.	E. replace gear or drive cap assy.
	F. broken piston retainer	F. replace drive cap assy.
	G. broken main or regenerant piston	G. replace main or regenerant piston
<b>7. Valve does not regenerate automatically when REGEN button is depressed</b>	A. transformer unplugged	A. connect transformer and PC board power
	B. no power at outlet	B. restore power
	C. broken drive gear or drive cap assy.	C. replace gear or drive cap assy.
	D. defective PC board	D. replace board
<b>8. Valve does not regenerate automatically but does when REGEN button is depressed</b>	A. bypass valve not in normal operating mode	A. see bypass diagrams on page 2
	B. meter disconnected	B. reconnect to PC board
	C. obstructed meter turbine	C. clear obstruction
	D. defective meter	D. replace meter
	E. programming error	E. review programming
	F. defective PC board	F. replace board
<b>9. Time of day flashes on and off</b>	A. Power has been out more than two hours. Transformer was unplugged from either wall outlet or form PC board. <b>NEXT</b> and <b>REGEN</b> were pressed to reset the valve.	A. reset time of day

# REPLACEMENT PARTS:

Replacement parts can be purchased by checking our website at [www.greenwaywt.com](http://www.greenwaywt.com), or by calling our customer service line at 1-866-253-0447, Monday to Thursday from 8:30 AM to 5:00 PM (EST), Friday from 8:30 AM to 4:00 PM (EST), or write: Greenway Water Technologies, Customer Service Center, 400 Southgate Drive, Guelph, ON, Canada N1G 4P5.

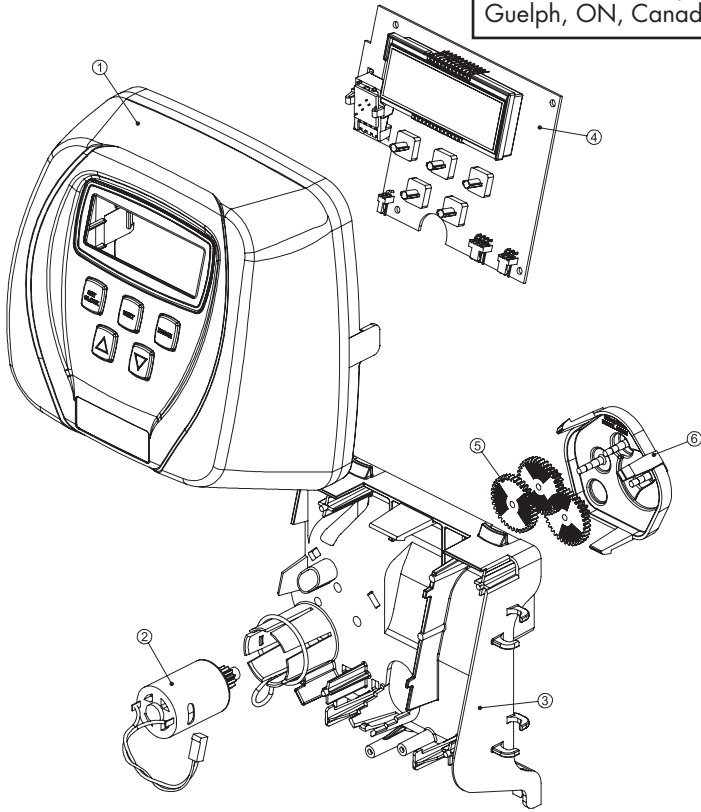

## FRONT COVER AND DRIVE ASSEMBLY

Item No.	Part No.	Description	Qty.
1	YY.WS.CV3175CC-01	Front cover assembly CC	1
2	YY.WS.CV3107-1	Motor	1
3	YY.WS.CV3106-1	Drive bracket & spring clip	1
4	YY.WS.CV3108CC	PC board, CC	1
6	YY.WS.CV3110	Drive gear, 12 x 36	3
6	YY.WS.CV3109	Drive gear cover	1
2-6	YY.WS.CV3002CC	Drive assembly, CC	-
not shown	YY.WS.CV3186	Transformer, 110V-12V	1

## PISTON ASSEMBLY

Item No.	Part No.	Description	Qty.
1	YY.WS.CV3005	Spacer stack assembly	1
2	YY.WS.CV3004	Drive cap assembly	1
3	YY.WS.CV3135	O-ring 228	1
4a	YY.WS.CV3011	Piston assembly downflow	1
4b	YY.WS.CV3011-01	Piston assembly upflow	1
5*	YY.WS.CV3174	Regenerant piston	1
6	YY.WS.CV3180	O-ring 337	1

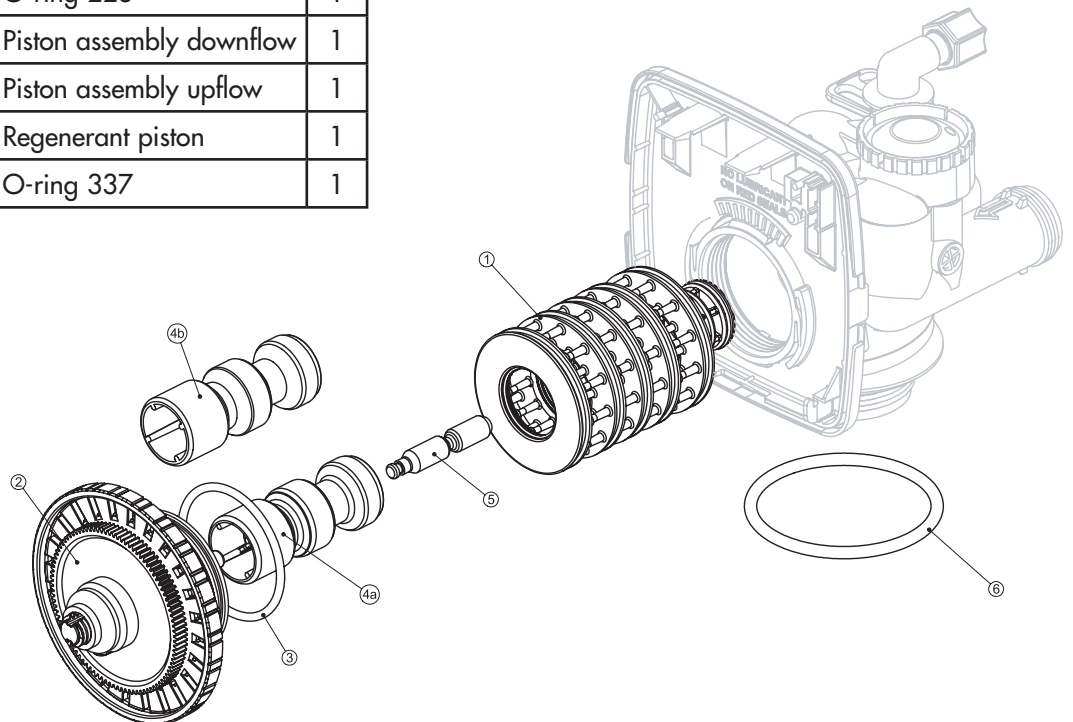

# REPLACEMENT PARTS:

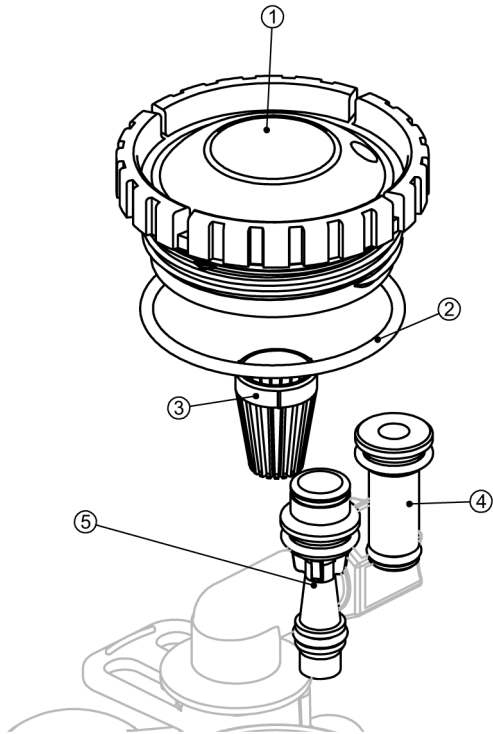

## INJECTOR ASSEMBLIES

Item No.	Part No.	Description	Qty.
1	YY.WS.CV3176	Injector cap	1
2	YY.WS.CV3152	O-ring 135	1
3	YY.WS.CV3177	Injector screen	1
4	YY.WS.CV3010-1Z	Injector assembly plug	1
5	YY.WS.CV3010-1E	<b>E</b> injector assembly, WHITE	
	YY.WS.CV3010-1F	<b>F</b> injector assembly, BLUE	
not shown	YY.WS.CV3170	O-ring 011, lower	*
not shown	YY.WS.CV3171	O-ring 013, lower	*

\* The injector plug and the injector each use one lower and one upper o-ring

## REFILL PORT ASSEMBLY

Item No.	Part No.	Description	Qty.
1*	YY.WS.CV3195-01	Refill port plug assembly	1
2	YY.WS.CH4615	Elbow locking clip	1
3	YY.WS.CJCP-P-6	Tube insert, 3/8	1
4	YY.WS.CJCPG-6PBLK	Nut, 3/8	1
5	YY.WS.CH4613	Elbow cap, 3/8	1
6	YY.WS.CV3163	O-ring 019	1
7	YY.WS.CV3165-01**	Refill flow control retainer assy.	1
8	YY.WS.CV3182	Refill flow control (specify size)	1
not shown	YY.WS.CH4650	Elbow, 1/2" with nut & insert	OP

\*\* Assembly includes refill flow control (specify size)

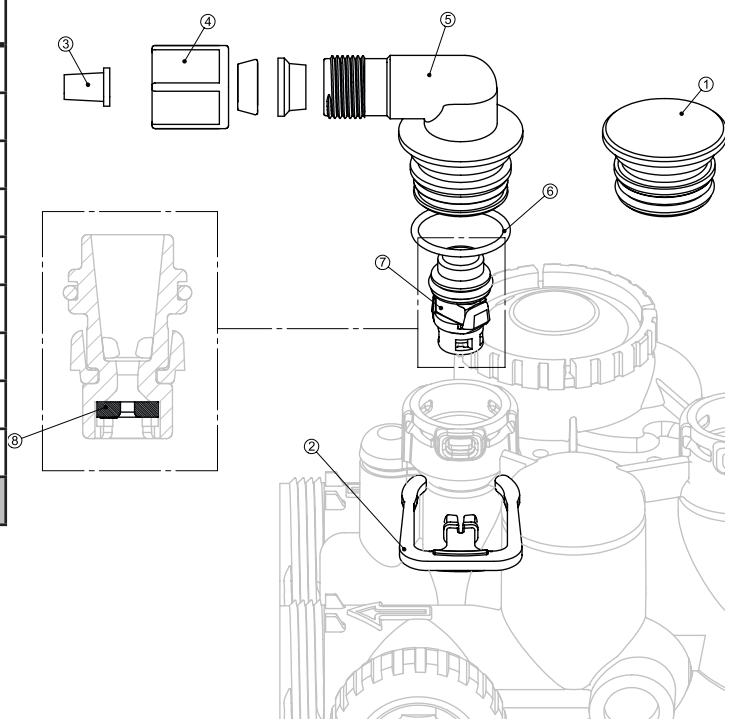

# REPLACEMENT PARTS:

## DRAIN LINE ASSEMBLY 3/4"

Item No.	Part No.	Description	Qty.
1	YY.WS.CH4615	Locking clip, elbow	1
2	YY.WS.CPKP10TS8-BULK	Insert, 5/8" tube	OP
3	YY.WS.CV3192	Nut, 3/4" drain elbow	OP
4	YY.WS.CV1358-01	Drain elbow assembly, 3/4" NPT	1
5	YY.WS.CV3163	O-ring 019	1
6	YY.WS.CV3159-01	DLFC retainer assembly	1
7	YY.WS.CV3162-007	0.7 DLFC for 3/4" elbow	1
	YY.WS.CV3162-010	1.0 DLFC for 3/4" elbow	
	YY.WS.CV3162-013	1.3 DLFC for 3/4" elbow	
	YY.WS.CV3162-017	1.7 DLFC for 3/4" elbow	
	YY.WS.CV3162-022	2.2 DLFC for 3/4" elbow	
	YY.WS.CV3162-027	2.7 DLFC for 3/4" elbow	
	YY.WS.CV3162-032	3.2 DLFC for 3/4" elbow	
	YY.WS.CV3162-042	4.2 DLFC for 3/4" elbow	
	YY.WS.CV3162-053	5.3 DLFC for 3/4" elbow	

Items 2 and 3, nut and insert are only used with 1/2" I.D. by 5/8" O.D. polytubing. For other piping material the 3/4" NPT is used.

**3/4" NPT**

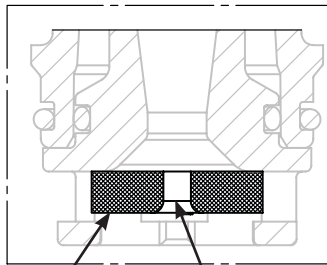
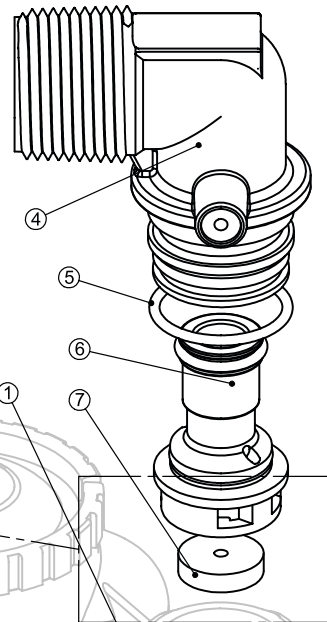
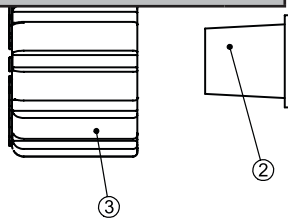

Proper DLFC orientation directs water flow towards the washer face with rounded edge and lettering.

Water Flow



# REPLACEMENT PARTS:

## WATER METER & METER PLUG

Item No.	Part No.	Description	Qty.
1	YY.WS.CV3151	Nut, 1" QC	1
2	YY.WS.CV3003	Meter assembly, includes items 3 & 4	1
3	YY.WS.CV3118-01	Turbine assembly	1
4	YY.WS.CV3105	O-ring 215	1
5	YY.WS.CV3003-01	Meter plug assembly	1

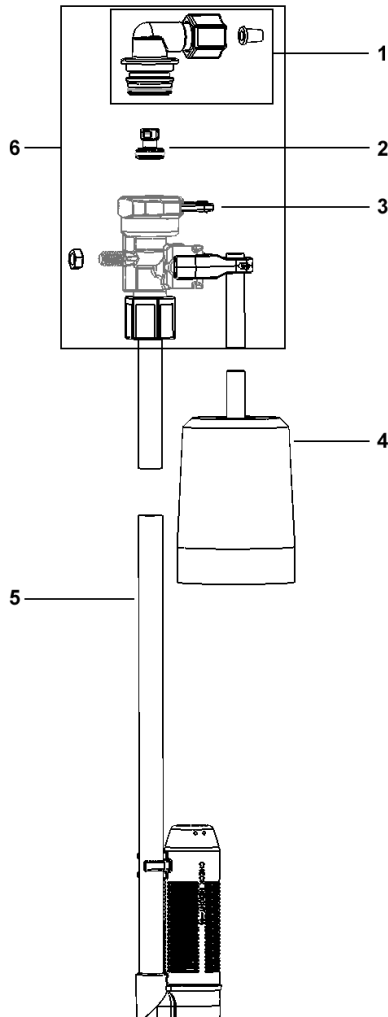
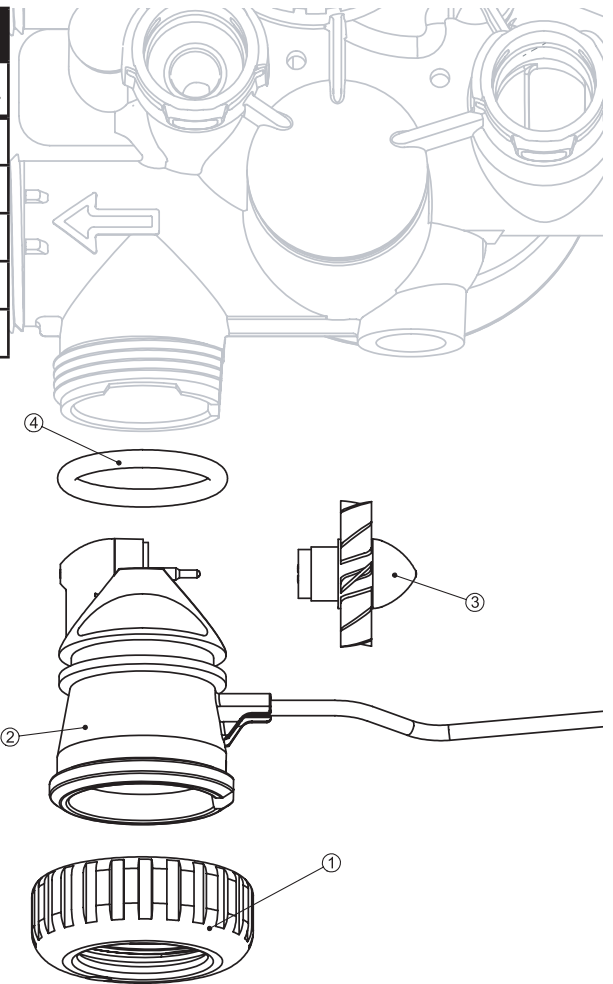

## SAFETY FLOAT ASSEMBLY

Item No.	Part No.	Description
1	YY.WS.CH4650-01	474 safety elbow 3/8"
2	YY.WS.CH4655	474 .5 gpm flow control
3	YY.WS.CH4615	Elbow locking clip
4	YY.WS.CH4640-32	474 float assm 32" w/ grommets
5	YY.WS.CH4500-48	474 aircheck assm 1/2" x 48"
6	YY.WS.CH4600	474 safety brn vlv w/ 3/8" elbow
7	YY.WS.CH4600-50	474 safety brn vlv .5 GPM
100	YY.WS.CH4700-27WR-1	.5 gpm safety float a/c assm com

# REPLACEMENT PARTS:

## BYPASS VALVE

Item No.	Part No.	Description	Qty.
1	YY.WS.CV3151	Nut, 1" quick connect	2
2	YY.WS.CV3150	Split ring	2
3	YY.WS.CV3105	O-ring 215	2
4	YY.WS.CV3145	Bypass rotor, 1"	2
5	YY.WS.CV3146	Bypass cap	2
6	YY.WS.CV3147	Bypass handle	2
7	YY.WS.CV3148	Bypass rotor seal retainer	2
8	YY.WS.CV3152	O-ring 135	2
9	YY.WS.CV3155	O-ring 112	2
10	YY.WS.CV3156	O-ring 214	2

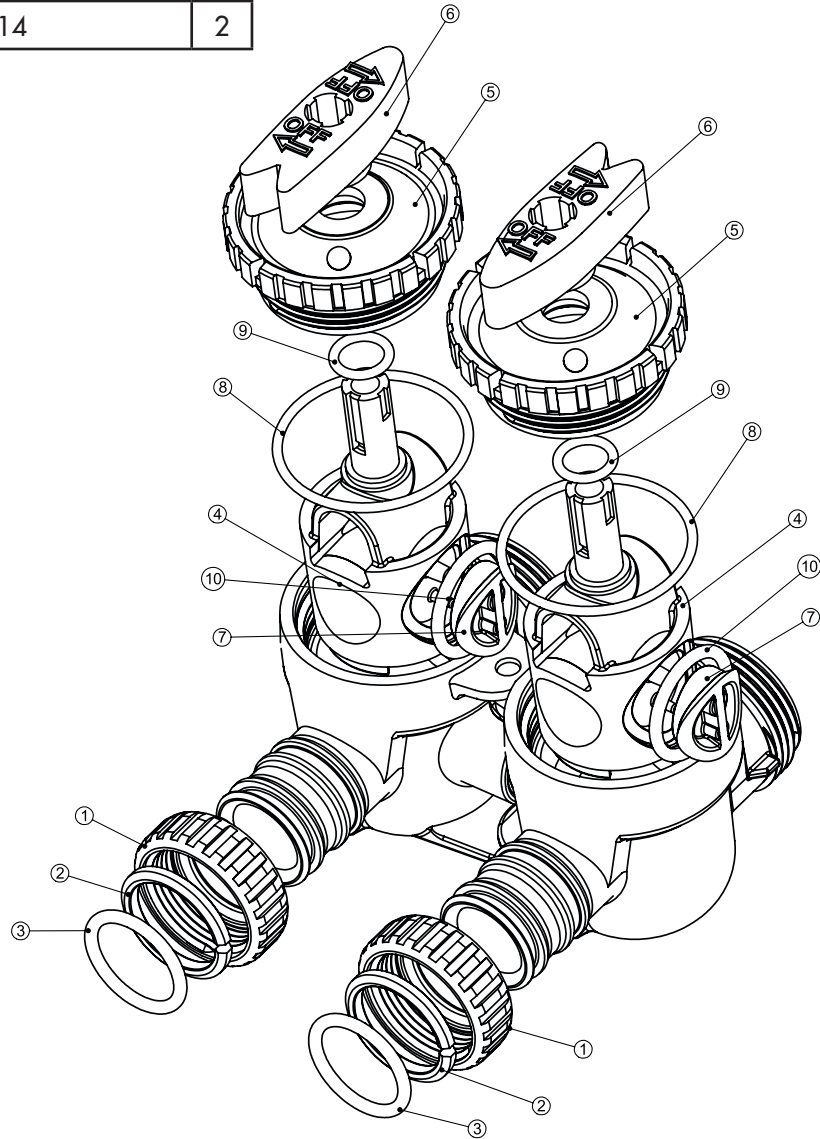

# INSTALLATION FITTING ASSEMBLIES:

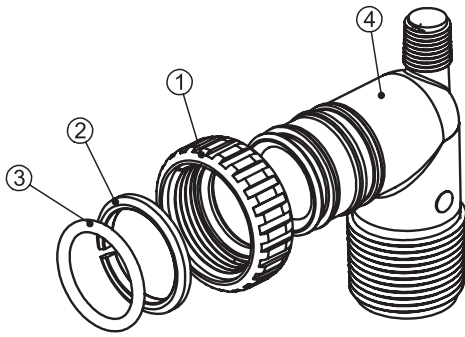

## 1" PVC MALE NPT ELBOW

Item No.	Part No.	Description	Qty.
	YY.WS.CV3007	1" PVC male NPT elbow assy.	2
1	YY.WS.CV3151	Nut, 1" quick connect	2
2	YY.WS.CV3150	Split Ring	2
3	YY.WS.CV3105	O-ring 215	2
4	YY.WS.CV3149	Fitting	2

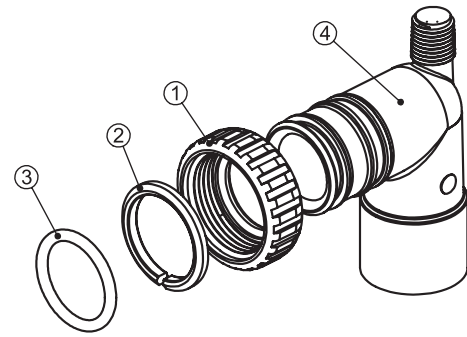

## 3/4" & 1" PVC SOLVENT ELBOW

Item No.	Part No.	Description	Qty.
	YY.WS.CV3007-01	3/4" & 1" PVC solvent elbow assy.	2
1	YY.WS.CV3151	Nut, 1" quick connect	2
2	YY.WS.CV3150	Split Ring	2
3	YY.WS.CV3105	O-ring 215	2
4	YY.WS.CV3189	Fitting	2

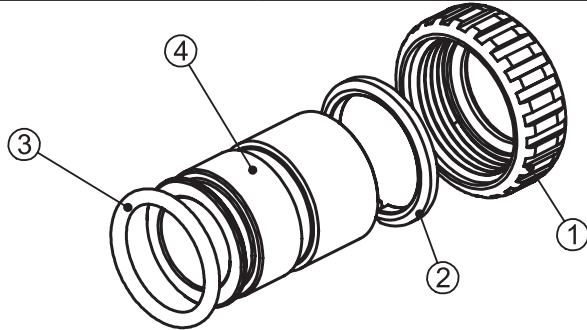

## 1" BRASS SWEAT

Item No.	Part No.	Description	Qty.
	YY.WS.CV3007-02	1" brass sweat assembly	2
1	YY.WS.CV3151	Nut, 1" quick connect	2
2	YY.WS.CV3150	Split Ring	2
3	YY.WS.CV3105	O-ring 215	2
4	YY.WS.CV3188	Fitting	2

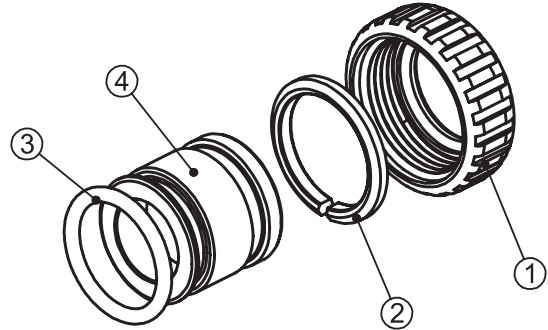

## 3/4" BRASS SWEAT

Item No.	Part No.	Description	Qty.
	YY.WS.CV3007-03	3/4" brass sweat assembly	2
1	YY.WS.CV3151	Nut, 1" quick connect	2
2	YY.WS.CV3150	Split Ring	2
3	YY.WS.CV3105	O-ring 215	2
4	YY.WS.CV3188-01	Fitting	2

## SERVICE WRENCH - YY.WS.CV3193

Although no tools are necessary to assemble or disassemble the valve, the *Service Wrench*, (shown in various positions on the valve) is available to aid in assembly or disassembly

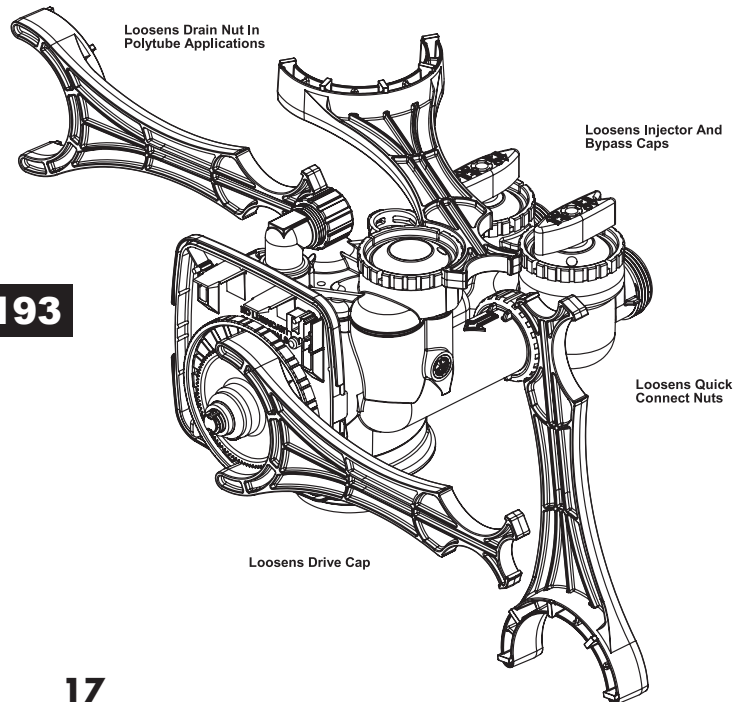

# QUICK REFERENCE GUIDE:

## GENERAL OPERATION

When the system is operating, one of three displays will be shown: Time of day, gallons of treated water available, or gallons per minute. Pressing **NEXT** will toggle between the three choices.

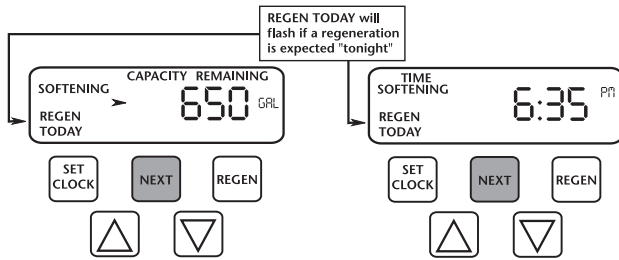

## MANUAL REGENERATION

**NOTE:** For softeners, if brine tank does not contain salt, fill with salt and wait at least 2 hours before regeneration. If you need to initiate a manual regeneration, either immediately, or the same night at the preprogrammed time for regeneration (typically 2:00 AM), complete the following steps.

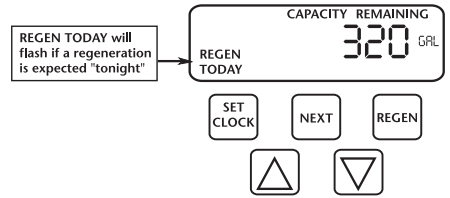

**For Immediate Regeneration:** Press and hold **REGEN** until valve motor starts (typically 3 seconds).

**For Regeneration the same night:** Press and release **REGEN** (notice that flashing "REGEN TODAY" appears).

## TO SET TIME OF DAY

In the event of a prolonged power outage, time of day flashes, indicating that this needs to be reset. All other information will be stored in memory no matter how long the power outage. Please complete the steps as shown to the right. To access this mode, press **SET CLOCK**.

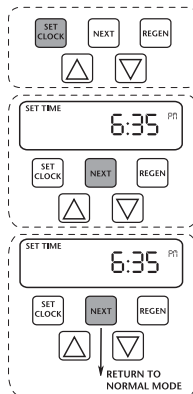

1. Accessed by pressing **SET CLOCK**
2. Adjust hours with and buttons, AM/PM toggles at 12
3. Press **NEXT**
4. Adjust minutes with and buttons
5. Press **NEXT** to complete and return to normal operation

## ERROR

If the display toggles between "Error" and an error code (i.e. a number), call a service technician and report the error code.

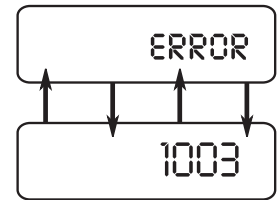

## BYPASS VALVE OPERATION

To shut-off water to the system, please position arrow handles as shown in the bypass operation diagram below. If your valve doesn't look like the diagram below, contact your service technician for instructions on how to shut off water.

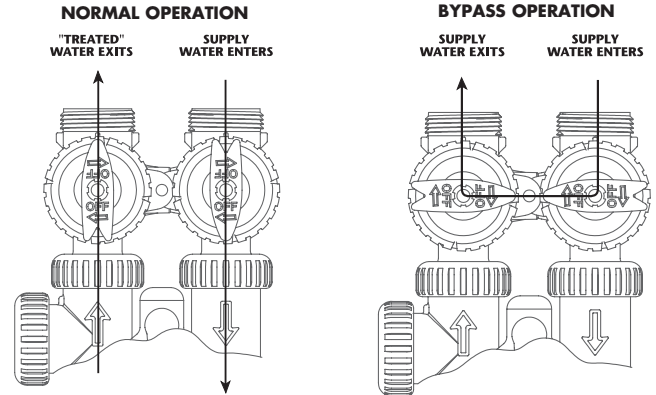

## ADJUST HARDNESS, DAYS BETWEEN REGENERATION, OR TIME OF REGENERATION

For initial set-up or to make adjustments, please complete the steps as shown to the right. Access this mode by pressing **NEXT** and button simultaneously.

**NOTE:** Hardness display shows "-nA-" if used as a filter. If other displays do not appear, refer to manual.

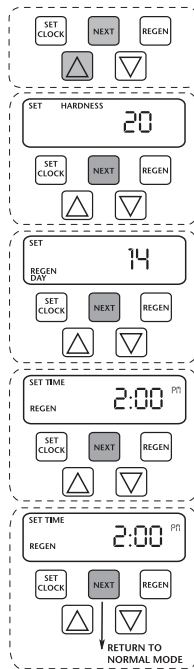

1. Accessed by pressing **NEXT** and ▲ button simultaneously
2. Adjust hardness using ▼ and ▲ buttons
3. Press **NEXT**
4. Adjust days between regenerations using ▼ and ▲ buttons
5. Press **NEXT**
6. Adjust time of regeneration hour with ▼ and ▲ buttons, AM/PM toggles at 12.
7. Press **NEXT**
8. Adjust time of regeneration minutes with ▼ and ▲ buttons
9. Press **NEXT** to complete and return to normal operation.

**Greenway**  
Water Technologies