

CLICK ANYWHERE on THIS PAGE to RETURN to InspectApedia.com

ELECTRIC & GAS SERVICE REQUIREMENTS

(TD-7001M)

2017–2018

Visit us at

www.pge.com/greenbook

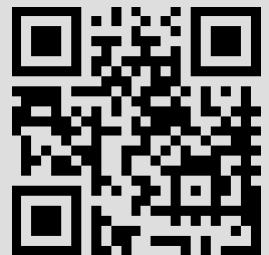

***Pacific Gas and
Electric Company***TM

WE DELIVER ENERGY.SM

Pacific Gas and Electric Company (PG&E)
Electric and Gas Service Requirements
(TD-7100M)

Architects and Engineers
Electrical Contractors
Plumbing Contractors
City and County Building Inspectors
Manufacturers of Electrical Equipment
Pacific Gas and Electric Company Employees

2017–2018 Edition

(Supersedes All Previous Editions and Revisions)

The *Electric and Gas Service Requirements* is a **guide to Pacific Gas and Electric Company (PG&E) requirements and policies** for establishing electric and gas service to **new or remodeled applicant installations.**

In addition to the utility requirements, **local or state officials may stipulate additional provisions for the installation of equipment and materials** that are in their authorized areas of responsibility and jurisdiction.

Should you have any questions regarding this manual, please call your local PG&E representative (see Table FM-1, “Service Planning Office Contact Information,” starting on Page iv.).

Applicant gas and electric service and meter installation arrangements are subject to PG&E’s review and approval. Applicants should contact their local PG&E representatives as soon in the planning process as possible.

NOTE: The acronym PG&E is used throughout this manual to designate Pacific Gas and Electric Company.



The PG&E *Electric and Gas Service Requirements (Greenbook)* is updated and published yearly. The 2017–2018 *Greenbook* supersedes all previous editions and revisions and the requirements, here in, are effective until a new revision is released the following year.

Notice: This Manual Is Subject to Change

Information and requirements in this manual are subject to change over time.

PG&E may revise its design and construction documents relating to applicant service requirements between updates to this manual. Except when required by law, the version of the design and construction document in effect on the date the applicant's service design is approved and signed-off by the PG&E supervisor determines the requirements that the design must meet. These requirements apply as long as applicants complete approved projects within 12 months. If the applicant has not initiated construction within 12 months of PG&E's initial approval, PG&E may initiate the review of the design and, if warranted, refresh the cost estimate. If the applicant does not fulfill obligations under the extension agreement, PG&E may, at its discretion, cancel the agreement (see Provisions Form 62–0982, Section 20). PG&E can then request another review of the design before approving construction activities.

The online versions of the *Electric & Gas Service Requirements*, located at www.pge.com/greenbook, are updated as quickly as possible when changes occur. The bound manual is not reprinted until the next scheduled print date regardless of changes in processes or requirements. Therefore, it is **imperative** that applicants for all gas and electric service projects consult the online version of this book (www.pge.com/greenbook) before finalizing project plans.



PG&E:
 More than
 just a utility . . .
 a full-service company!

For more information, please
 contact your local PG&E project
 coordinator.

— Denotes PG&E area.
 See the “Service
 Planning Office Contact
 Information” starting on
 Page iv.



Table FM-1 Service Planning Office Contact Information

Service Planning Office Contact Information						
PG&E Area	Local Headquarters	Address	Zip Code	External Phone Number	Inspection Desk	
					Phone	Email Address
5	Angels Camp	1108 Murphys Grade Rd	95222	(209) 942-1495	(209) 942-1495 (209) 942-1408	EDLHCCDStockon@pge.com
2	Antioch	2111 Hillcrest Ave	94509	(925) 779-7757	(925) 779-7757 (925) 779-7750	EDLHCCDAntioch@pge.com
6	Auburn	333 Sacramento St	95603	(530) 889-3270	(530) 889-3271 (530) 889-5165 (530) 889-5183	EDLHCCDAuburn@pge.com
4	Bakersfield	4101 Wible Rd	93313	(661) 398-5931	(661) 398-3989 (661)398-5864	EDLHCCDKern@pge.com
6	Chico	460 Rio Lindo Ave	95926	(530) 894-4749	(530) 894-4734 (530) 894-4414	EDLHCCDChico@pge.com
2	Concord	1030 Detroit Ave	94518	(925) 674-6457	(925) 779-7757 (925) 779-7750	EDLHCCDAntioch@pge.com
3	Cupertino	10900 N. Blaney	95014	(408) 725-3325	(408) 725-2202 (408) 725-7773	EDLHCCDDeAnza@pge.com
4	Dinuba	8058 Union St	93618	(559) 591-2314	(559) 263-7400 (559) 263-5488	EDLHCCDFresno@pge.com
7	Eureka	2555 Myrtle Ave	95501	(707) 445-5533	(707) 445-5533 (707) 445-5528	EDLHCCDHumboldt@pge.com
2	Fremont	41800 Boscell Rd	94538	(510) 784-3210	(510) 784-3317 NA	MissionInspections@pge.com
4	Fresno	705 P St, 2nd Floor	93760	(559) 263-7400	(559) 263-7400 (559) 263-5488	EDLHCCDFresno@pge.com
6	Grass Valley	788 Taylorville Rd	95949	(530) 477-3244	(916) 201-0168 (530) 477-3269	CCDGrassValleyInspec@pge.com
2	Hayward	24300 Clawiter Rd	94545	(510) 784-3210	(510) 784-3317 NA	MissionInspections@pge.com
5	Jackson	12626 Jackson Gate Rd	95642	(209) 942-1495	(209) 942-1495 (209) 942-1408	EDLHCCDStockon@pge.com
2	Livermore	998 Murietta Blvd	94550	(925) 373-2620	(510) 784-3317 NA	MissionInspections@pge.com
5	Madera	2871 Airport Dr	93637	(559) 675-2220	(209) 726-6373 (209) 726-6446	EDLHCCDStockon@pge.com
5	Manteca	226 E. Yosemite St	95336	(209) 942-1495	(209) 942-1495 (209) 942-1408	EDLHCCDStockton@pge.com
5	Mariposa	5166 Jones St	95338	(209) 966-3446	(800) 564-5080 (209) 726-7641	EDLHCCDYosemite@pge.com

Service Planning Office Contact Information, continued

PG&E Area	Local Headquarters	Address	Zip Code	External Phone Number	Inspection Desk	
					Phone	Email Address
6	Marysville	29 4th St	95901	(530) 634-6442	(530) 634-6442 (530) 634-6475	EDLHCCDMarysville@pge.com
5	Merced	3185 M St	95348	(800) 564-5080	(209) 726-6373 (209) 726-6446	EDLHCCDStockton@pge.com
5	Modesto	1524 N. Carpenter Rd	93637	(800) 564-5080	(209) 726-6373 (209) 726-6446	EDLHCCDStockton@pge.com
3	Monterey	2311 Garden Rd	93940	(831) 648-3224	(831) 784-3614 (831) 648-3252	CentralCoastInspect@pge.com
7	Napa	1850 Soscol Ave, Suite 105	94559	(707) 257-5918	(707) 257-5918 (707) 257-5938	NA
5	Oakhurst	50150 Rd 426	93644	(800) 564-5080	(209) 726-6373 (209) 726-6446	EDLHCCDYosemite@pge.com
2	Oakland	4801 Oakport St	94601	(510) 437-2233	(510) 437-2616 (510) 437-2144	EDLHCCDOakport@pge.com
6	Placerville	4636 Missouri Flat Rd	95667	(530) 621-7265	(530) 621-7265 (530) 621-7258	EDLHCCDPlacerville@pge.com
6	Redding	3600 Meadow View Dr	96002	(530) 246-6537	(530) 246-6546 (530) 246-6541	EDLHCCDRedding@pge.com
2	Richmond	1100 S. 27th St	94804	(510) 231-2852	(510) 231-2939 (510) 231-2872	EDLHCCDRichmond@pge.com
6	Sacramento	5555 Florin Perkins Rd	95826	(916) 386-5112	(916) 386-5112 (916) 386-5288	EDLHCCDSacramento@pge.com
3	Salinas	401 Work St	93901	(831) 784-3614	(831) 784-3614 (831) 784-3634	CentralCoastInspect@pge.com
1	San Carlos	275 Industrial Rd	94070	(650) 598-7204	(650) 598-7271 (650) 598-7297	EDLHCCDPeninsula@pge.com
1	San Francisco	2180 Harrison St	94110	(415) 695-3500	(415) 695-3500 (415) 695-3525	NA
3	San Jose	308 Stockton Ave	95126	(408) 299-9500	(408) 299-1024 (408) 299-1087	EDLHCCDSanJose@pge.com
4	San Luis Obispo	4325 Higuera	93401	(805) 546-5247	(805) 546-5247 NA	NA
7	San Rafael	1220 Andersen Dr	94901	(415) 257-3431	(415) 257-3130 (415) 257-3429	NA
3	Santa Cruz	615 7th Ave	95062	(831) 479-3114	(831) 784-3614 (831) 479-3115	CentralCoastInspect@pge.com
4	Santa Maria	2445 Skyway Dr	93455	(805) 346-2241	(805) 546-5247 NA	NA

Service Planning Office Contact Information, continued

PG&E Area	Local Headquarters	Address	Zip Code	External Phone Number	Inspection Desk	
					Phone	Email Address
7	Santa Rosa	3965 Occidental Rd	95401	(707) 579-6476	(707) 579-6418 (707) 579-6418	EDLHCCDSantaRosa@pge.com
4	Selma	2139 Sylvia St	93662	(559) 891-2143	(559) 263-7400 (559) 263-5488	EDLHCCDFresno@pge.com
5	Stockton	4040 West Ln	95204	(209) 942-1495	(209) 942-1495 (209) 942-1408	EDLHCCDStockton@pge.com
4	Templeton	160 Cow Meadow Pl	93446	(805) 434-4460	(805) 546-5247 NA	NA
7	Ukiah	2641 N. State St	95482	(707) 468-3914	(707) 468-3914 (707) 468-3967	EDLHCCDUkiah@pge.com
6	Vacaville	158 Peabody Rd	95688	(707) 449-5720	(707) 449-5720 (707) 449-5774	EDLHCCDVacaville@pge.com
6	Woodland	242 N. West St	95695	(530) 661-5609	(530) 661-5609 (530) 661-5652	EDLHCCDWoodland@pge.com

Customer Quick Reference Notes	
<i>Greenbook</i> Section Number, Title, and/or Topic	Page #

Customer Quick Reference Notes, continued

<i>Greenbook</i> Section Number, Title, and/or Topic	Page #

Table of Contents

Contents	Page
Notice: This Manual Is Subject to Change	ii
Service Planning Office Contact Information	iv
Section 1 General	1-1
1.1. Purpose	1-2
1.2. Permits and Inspections	1-3
1.3. Applying for Building and Renovation Services	1-3
1.4. Changes in Requirements	1-5
1.5. Additional Commercial and Industrial Service Information	1-6
1.6. Design and Construction	1-6
1.6.1. PG&E's Responsibilities	1-6
1.6.2. Applicant's Responsibilities	1-6
1.6.3. Providing Access to PG&E Electric Facilities	1-7
1.6.4. Installing Transformers	1-7
1.7. Connecting and Sealing Services	1-7
1.8. Access to an Applicant's Residence, Building, or Property	1-8
1.9. Overhead Electric Lines	1-9
1.10. Underground Electric Lines and Gas Pipelines	1-10
1.11. PG&E Safety Training Resources	1-10
1.12. SmartMeter™ Program	1-10
1.13. PG&E Online (Website)	1-10
1.13.1. Electric and Gas Service Requirements Manual (aka Greenbook)	1-11
1.13.2. Rates and Tariffs	1-11

Contents	Page
<hr/>	
Section 1 General, continued	
1.14. Determining the Service Rating	1-11
1.15. Changing an Applicant’s Approved Project or Existing Service Loads	1-12
1.15.1. Upgrading, Replacing, Relocating Electric Facilities, or Adding Power Generation Sources	1-13
1.16. Standard Residential Service Voltage	1-14
1.16.1. Single-Phase Service	1-14
1.16.2. Three-Phase Service	1-14
1.16.3. Mixed-Use Projects	1-15
Section 2 Gas Service	2-1
2.1. Scope	2-1
2.2. Procedures for Establishing Gas Service	2-1
2.2.1. Establishing New Gas Service	2-1
2.2.2. Relocating or Adding Load to an Existing Service	2-4
2.3. Gas Service Lateral	2-4
2.3.1. General	2-5
2.3.2. Branch Service Pipe	2-10
2.3.3. Curb Valves	2-10
2.3.4. Joint Utility Service Trenches	2-11
2.3.5. Multiple Buildings Located on One Lot	2-14
2.3.6. Mobile Home Parks	2-17
2.4. Set Requirements for Gas Meters	2-18
2.4.1. Gas Pressure	2-18
2.4.2. Gas Meter-Set Locations	2-19

Contents	Page
Section 2 Gas Service, continued	
2.5. Applicant-Owned and Installed Gas Service Piping (e.g., Houseline), Valves, and Automatic Shut-Off Devices	2-42
2.5.1. Service Delivery Point For the Gas Supply	2-43
2.5.2. Applicant-Owned Riser and Pipe	2-44
2.5.3. Electrically Bonding and Grounding Gas Pipe	2-46
2.5.4. Applicant-Owned Protective Equipment	2-46
Section 3 Electric Service: Underground	3-1
3.1. Scope	3-1
3.2. General Information	3-1
3.2.1. Safety Reminder	3-1
3.2.2. Establishing Underground Electric Service Responsibilities	3-2
3.2.3. Installing Ground Rods	3-4
3.2.4. Installing Equipment Pads	3-4
3.2.5. Installing Overhead and Underground Service for Two or More Buildings on One Lot	3-4
3.2.6. Inspecting and Approving Overhead and Underground Services ...	3-5
3.3. Underground Service Installation Requirements	3-5
3.3.1. Installing Services From Underground Distribution Systems	3-5
3.3.2. Installing Services From Overhead Distribution Systems	3-6
3.3.3. Installing Conduit for Underground Service	3-7
3.3.4. Installing PG&E-Only Service Trenches	3-8
3.3.5. Installing Offsets	3-9
3.3.6. Selecting Backfill	3-10
3.3.7. Providing Drainage From the Conduit System	3-10
3.3.8. Installing Joint Utility Service Trenches	3-11
3.3.9. Providing a Service-Termination Facility	3-13
3.3.10. Bioswales and Large Wet Locations	3-14

Contents	Page
Section 3 Electric Service: Underground, continued	
3.4. Electric Underground Documents	3-14
3.4.1. Mandrels	3-15
Section 4 Electric Service: Overhead 4-1	
4.1. Scope	4-1
4.2. General	4-1
4.2.1. Safety Reminder	4-1
4.3. Locating Overhead Services	4-1
4.3.1. Point of Attachment	4-1
4.3.2. Two or More Buildings on One Lot	4-3
4.4. Service Drop Clearances	4-3
4.4.1. Vertical Clearance for Residential, Overhead Service	4-4
4.4.2. Clearance Above Buildings	4-7
4.4.3. Clearance at the Residential Point of Attachment	4-8
4.4.4. Vertical Clearance on Nonresidential Property	4-10
4.4.5. Clearances for a Nonresidential Building Service Drop Using Cable or Equally Insulated, Open-Wire Service Conductors	4-11
4.4.6. Clearances Around Doors and Windows	4-14
4.4.7. Clearance Between Service Drop Wires	4-14
4.4.8. Clearance From Applicant-Owned Service Poles	4-15
4.5. Service Attachments	4-15
4.5.1. Attaching Low-Voltage, Residential, Overhead Service Drops	4-15
4.5.2. Attaching Low-Voltage, Nonresidential, Overhead Service Drops	4-17
4.5.3. Special Service Attachment Requirements: Areas Subject to Heavy Snow Loading	4-19

Contents	Page
Section 4 Electric Service: Overhead, continued	
4.6. Attachment Structures (Periscopes)	4-21
4.6.1. Periscope Clearances and Bracing Requirements	4-22
4.7. Service Weatherheads	4-23
4.8. Service-Entrance Conductors	4-24
4.9. Applicant-Owned, Installed, or Furnished Wood Poles	4-25
4.10. Required Vegetation Clearances	4-26
4.10.1. General Requirements	4-26
4.10.2. Planning Requirements	4-28
4.10.3. Existing Overhead Lines Adjacent to Developments	4-29
4.10.4. Line Extensions	4-29
4.10.5. Primary Overhead Distribution Poles in Commercial Orchard Installations	4-30
4.10.6. Removing Vegetation Near Existing, High-Voltage, Energized Lines	4-30
Section 5 Electric Metering: General	
5-1	
5.1. Scope	5-1
5.2. General Conditions and Responsibilities	5-1
5.2.1. Approved Metering and Service Termination Equipment	5-1
5.2.2. Drawing Submittal Requirements for Metering and Service Termination Equipment	5-1
5.2.3. Applicant Responsibilities	5-2
5.2.4. Requirements for Installing Secondary Terminations (0–600 Volt) in Metering Equipment Requiring CTs	5-4

	Contents	Page
<hr/>		
Section 5	Electric Metering: General, continued	
5.3.	Electric Meters: General Location Requirements	5-5
5.3.1.	Basic Meter Location Requirements	5-6
5.3.2.	Prohibited Meter and Service Equipment Locations	5-6
5.3.3.	Locating and Grouping Multiple Meters	5-7
5.3.4.	Electric Meter Rooms	5-8
5.4.	Meter Heights, Clearances, Enclosures, and Protection	5-9
5.4.1.	Meter Heights	5-9
5.4.2.	Meter Cabinet Enclosure Clearances	5-10
5.4.3.	Meter Set Clearance Requirements	5-11
5.4.4.	Working Space	5-12
5.4.5.	Barricades	5-15
5.4.6.	Meter Protection	5-15
5.5.	Meter Identification and Seals	5-15
5.5.1.	Properly Identifying and Marking Meters	5-15
5.5.2.	Sealing Meters and Metering Equipment	5-16
5.5.3.	Locking Provisions	5-17

Contents	Page
Section 5 Electric Metering: General, continued	
5.6. Meter Types and Connections	5-17
5.6.1. Using a Meter Socket Adapter for Overhead-to-Underground Conversion	5-20
5.6.2. Installing Non-Allowed and Unauthorized Customer Equipment	5-20
5.6.3. Fire-Pump Connections	5-20
5.7. Main Service Disconnects and Switching Sequences	5-22
5.7.1. Main Service Disconnects	5-22
5.7.2. Main Service Disconnect Switch Rated for Amperes Interrupting Capacity (AIC)	5-23
5.7.3. Arc Flash Assessment	5-23
5.7.4. Electronic Trip Circuit Breakers	5-23
5.7.5. Meter and Main Service Switch Sequence	5-24
5.8. Grounding	5-26
5.9. Temporary Service	5-29
5.9.1. Temporary Service Using Permanent Service Panels	5-29
5.9.2. Temporary-Service Metering Pedestal	5-30
5.9.3. Temporary Plug-In Service	5-31

Contents	Page
<hr/>	
Section 5 Electric Metering: General, continued	
5.10. Connecting Non-Utility Power Sources to Utility Services	5-31
5.10.1. Specific Interconnection Requirements for Services Up to 600 Volts	5-32
5.10.2. Warning Statements and Labels for Interconnected Services	5-35
5.10.3. Violation	5-35
5.11. Plug-In Electric Vehicle Interconnections	5-36
Section 6 Electric Metering: Residential	6-1
6.1. Scope	6-1
6.2. Residential Electric Service: Specifications and Requirements	6-1
6.2.1. Service Classes	6-1
6.2.2. Test-Bypass Facilities	6-1
6.3. Residential Electric Metering Pedestals	6-2
6.4. Meter Locations	6-2
6.4.1. Installing Utility Services to Mobile Homes	6-3
6.5. Services	6-4
6.5.1. Single Meter: Underground Service	6-4
6.5.2. Single Meter: Overhead Service	6-9
6.5.3. Multiple Meters	6-12

Contents	Page
<hr/>	
Section 7 Electric Metering: Commercial, Industrial, and Agricultural	7-1
7.1. Scope	7-1
7.2. Service Specifications and Requirements	7-1
7.2.1. Permitted Types of Electric Service	7-1
7.2.2. Required Test-Bypass Facilities	7-1
7.2.3. Required Approvals for Meter Equipment Without Test-Bypass Facilities	7-2
7.2.4. Meter Locations	7-2
7.2.5. Services, 0 Amps Through 200 Amps, Single Applicant, Overhead and Underground	7-3
7.2.6. Services, Over 200 Amps, Single Applicant, Underground	7-5
7.2.7. Services, Over 200 Amps, Single Applicant, Overhead	7-9
7.2.8. Multi-Applicant Meter Installations	7-13
Section 8 Electric Metering: Direct Access	8-1
8.1. Scope	8-1
Section 9 Electric Metering: Components	9-1
9.1. Scope	9-1
9.2. Test Blocks for Self-Contained Metering, 0 Amps Through 225 Amps	9-1
9.3. Test Switch Mounting Base Detail	9-2
9.4. Separate CT Cabinet, 201 Amps and Above, Single Phase and Three Phase	9-3
9.5. CT Mounting Base, 201 Amps Through 400 Amps	9-4
9.6. Alternate CT Mounting Base, 3-Wire, One Phase or Three Phase	9-5
9.7. Bused CT Cabinet, 3-Wire Service, 201 Amps Through 800 Amps	9-6

Contents	Page
Section 9 Electric Metering: Components, continued	
9.8. Bused CT Cabinet, 4-Wire Service, 201 Amps–800 Amps	9-7
9.9. Meter Box for Transformer-Rated Metering	9-8
9.10. Underground Service Cable-Termination Section or Pull Box	9-10
9.11. Approved Service-Terminal Conductor Connectors	9-14
9.12. Underground-Service Auxiliary Pull Cabinet	9-15
9.13. Nonresidential Service Pedestals 0 - 200 Amps (EUSERC 308)	9-17
Section 10 Electric Switchboards: 0 Volts Through 600 Volts	
10.1. Scope	10-1
10.2. General Requirements	10-1
10.3. Switchboard Service Section	10-2
10.3.1. Standard Switchboard Service Section	10-3
10.3.2. Specifically Engineered Switchboard Service Sections	10-3
10.3.3. Requirements for All Switchboard Service Sections	10-3
10.3.4. Standard Switchboard CT Compartment, 0 Amps Through 1,200 Amps, Single-Phase or Three-Phase, 3-Wire Service	10-6
10.3.5. Standard Switchboard CT Compartment, 0 Amps Through 1,200 Amps, Three-Phase, 3-Wire and 4-Wire Services	10-8
10.3.6. Standard Switchboard CT Compartment, 1,001 Amps Through 3,000 Amps, Single-Phase or Three-Phase, 3-Wire Service	10-9
10.3.7. Standard Switchboard, CT Compartment, 1,001 Amps Through 3,000 Amps, Three-Phase, 4-Wire Service	10-11
10.3.8. Standard Switchboard CT Compartment, 3,001 Amps and Larger, Three-Phase, 3-Wire Service	10-13
10.3.9. Standard Switchboard CT Compartment, 3,001 Amps and Larger, Three-Phase, 3-Wire or 4-Wire Service	10-15
10.3.10. Removable Link Assemblies	10-17

Contents	Page
Section 10 Electric Switchboards: 0 Volts Through 600 Volts, continued	
10.3.11. Standard Section for Self-Contained Meter Sockets, 0 Amps Through 225 Amps, Installed in Switchboards: Nonresidential	10-22
10.3.12. Service Terminations for Underground Services	10-24
10.3.13. Underground, Service-Termination Pull Section (Located Below Ground Level)	10-26
10.3.14. Underground, Cable-Terminating Facilities in Pull Boxes or Pull Sections	10-30
10.4. Meter and Switch Sequence Requirements	10-33
10.5. Metering Transformer Compartments	10-34
10.6. Meter Panels	10-34
10.7. Transformer-Rated and Self-Contained Switchboards	10-39
10.8. Adding New Metering Equipment to Existing Switchboards	10-40
Section 11 Electric Switchboards: 601 Through 25,000 Volts and Primary Services	
11-1	
11.1. Scope	11-1
11.2. General Requirements	11-1
11.3. Specific Requirements for High-Voltage Switchboards	11-2
11.4. Interconnection Requirements and Primary Services	11-10
Appendix A Acronyms and Glossary	A-1
Appendix B Electric and Gas Service Documents	B-1
Appendix C Electric and Gas Engineering Documents	C-1

This Page Intentionally Left Blank

List of Tables

Contents	Page
Section 1 General	
Table 1-1 USA Color Coding ¹	1-1
Table 1-2 Minimum Safe Working Distances (Scaffolds, Equipment, Tools, Structures, and People)	1-9
Table 1-3 Minimum Safe Working Distances (Boom-Type Lifting or Hoisting Equipment)	1-9
Section 2 Gas Service	
Table 2-1 Minimum Separation and Clearance Requirements for Trenches ¹	2-12
Table 2-2 Dimensions to Figure 2-22	2-34
Section 3 Electric Service: Underground	
Table 3-1 Minimum Separation and Clearance Requirements for Trenches ¹	3-13
Table 3-2 Electric Underground Numbered Documents	3-14
Table 3-3 Mandrel Dimensions, Part Numbers, and Order Codes ¹	3-17
Table 3-4 Businesses That Sell or Rent Mandrels ¹	3-18
Section 4 Electric Service: Overhead	
Table 4-1 Minimum Clearances Over Swimming Pools ¹	4-6
Table 4-2 Minimum Allowable Clearance of Insulated Service Drops From Buildings – 0 Volts Through 750 Volts	4-7
Table 4-3 Vertical Clearance From the Ground on Nonresidential Property ¹	4-10
Table 4-4 Maximum Distance “L” (Inches From the Service Attachment to the Top Periscope Support)	4-20

Contents	Page
Section 5 Electric Metering: General	
Table 5-1 Meter Cabinet Enclosure Clearance Dimensions	5-10
Table 5-2 Working Space Dimensional Requirements ¹	5-12
Table 5-3 Meter Socket Requirements (Number of Jaws)	5-18
Table 5-4 Requirements For AC Disconnect Switches	5-32
Section 6 Electric Metering: Residential	
Table 6-1 Residential (0 Amps–225 Amps) Enclosure	6-5
Table 6-2 Dimension Specifications for Multimeter Installations	6-16
Section 9 Electric Metering: Components	
Table 9-1 CT Cabinet Minimum Dimensions	9-3
Table 9-2 Hinged Meter Panel Requirements	9-9
Table 9-3 Minimum Wall-Mounted Pull-Section Dimensions: Residential and Nonresidential, Single-Phase 1 or Three-Phase 1	9-11
Table 9-5 Approved, Compression-Type, Service-Terminal Connectors	9-15
Table 9-6 Minimum Connection Cabinet Sizes 1	9-16
Table 9-7 Minimum Dimensions (Inches)	9-19
Section 10 Electric Switchboards: 0 Volts Through 600 Volts	
Table 10-1 Minimum Bottom-Fed Pull-Section Dimensions	10-25
Table 10-2 Pull-Section Dimensions (Minimums) Below Ground Level	10-28

Contents	Page
Section 10 Electric Switchboards: 0 Volts Through 600 Volts, continued	
Table 10-3 Dual-Socket, Hinged, Meter-Panel Requirement	10-34
Table 10-4 Adding Up Meter Section Ampacities	10-41
Section 11 Electric Switchboards: 601 Through 25,000 Volts and Primary Services	
Table 11-1 Bill of Materials for Concrete Pad	11-4
Table 11-2 Dimensions for High-Voltage Meter Enclosures	11-7
Appendix B Electric and Gas Service Documents	
Table B-1 Plant Matrix for Stockton, Yosemite, Fresno, and Kern Divisions	B-2
Table B-2 Plant Matrix for San Francisco, Peninsula, and DeAnza Divisions	B-3
Table B-3 Plant Matrix for San Jose, Central Coast, and Los Padres Divisions . .	B-4
Table B-4 Plant Matrix for North Valley, Sierra, and Sacramento Divisions	B-5
Table B-5 Plant Matrix for Diablo, Mission, and East Bay Divisions	B-6
Table B-6 Plant Matrix for North Coast and North Bay Divisions	B-7
Table B-7 Do Not Plant These Trees Under or Within 15 Feet of Overhead Power Lines	B-8
Appendix C Electric and Gas Engineering Documents	
Table C-1 Gas Design Standards	C-1
Table C-2 Electric Engineering Documents	C-2

This Page Intentionally Left Blank

List of Figures

Contents	Page
Section 2 Gas Service	
Figure 2-1 Typical Gas Service Installation	2-6
Figure 2-2 Gas-Only Service Trench	2-9
Figure 2-3 Typical Gas Bell Hole–Plan View	2-9
Figure 2-4 Typical Bell Hole Depth–Profile View	2-9
Figure 2-5 Typical Joint-Service Trench	2-11
Figure 2-6 Separate Gas Services for Two Buildings on a Single Lot	2-14
Figure 2-7 Separate Gas Services for Two Buildings on a Corner Lot	2-15
Figure 2-8 Apartments With Grouped Meter Locations	2-16
Figure 2-9 Individually Metered Buildings	2-16
Figure 2-10 Property Line Installation	2-20
Figure 2-11 Acceptable Locations for Gas Meter Installations	2-22
Figure 2-12 Acceptable Meter Locations for Mobile Home Parks	2-23
Figure 2-13 Flex-Hose Meter Set–Residential and Small Commercial	2-24
Figure 2-14 Typical Residential Gas Meter Connection	2-26
Figure 2-15 Typical Gas Meter Connection for 400 to 1,000 Class Meters	2-27
Figure 2-16 Gas Meter Connection Using a 1.5M or 3M Rotary Gas Meter	2-28
Figure 2-17 Gas Meter Connection Using a 5M or 7M Rotary Gas Meter	2-29
Figure 2-18 Gas Meter Connection Using an 11M or 16M Rotary Gas Meter	2-30
Figure 2-19 Electric and Gas Meter Set Separation Dimensions and Clearances	2-31

Contents	Page
Section 2 Gas Service, continued	
Figure 2-20 Gas Meter Set Clearance From Building Openings	2-32
Figure 2-21 Gas Regulator Set Clearance Requirement from Sources of Ignition	2-33
Figure 2-22 Dimensions for Typical, Residential, Multimeter Installations	2-34
Figure 2-23 Recessed, Individual Meter Cabinet for Gas and Electric Meter Installations	2-36
Figure 2-24 Cabinet Dimensions for Multiple, Residential Gas Meters	2-37
Figure 2-25 Typical Detached Enclosure	2-38
Figure 2-26 Typical Enclosure Dimensions	2-39
Figure 2-27 Typical Residential, Multimeter Installations	2-44
Figure 2-28 Recommended, Applicant-Owned Riser and Pipe	2-45
Section 3 Electric Service: Underground	
Figure 3-1 Locations of Underground Electric Service-Termination and Meter Facilities	3-3
Figure 3-2 Underground-to-Underground Service Connection	3-5
Figure 3-3 Overhead-to-Underground Service Connection	3-6
Figure 3-4 Typical Joint Service Trench	3-12
Figure 3-5 PG&E Electric and Gas Service Trench	3-12
Figure 3-6 Flexible Steel Mandrel	3-17

Contents	Page
Section 4 Electric Service: Overhead	
Figure 4-1 Preferred and Alternate Locations for the Overhead Service Drop Attachment (see Note 2)	4-2
Figure 4-2 Ground Clearances for Supply Service Drops, 0 Volts Through 750 Volts, Residential Installations (Required by the CPUC)	4-4
Figure 4-3 Minimum Clearance for All Drops Above or Adjacent To Swimming Pools	4-6
Figure 4-4 Nonmetallic Roof	4-7
Figure 4-5 Clearance at the Residential Point of Attachment	4-9
Figure 4-6 Clearance at the Residential Point of Attachment	4-9
Figure 4-7 Clearance at the Residential Point of Attachment	4-9
Figure 4-8 Clearance at the Residential Point of Attachment	4-9
Figure 4-9 Clearance at the Residential Point of Attachment	4-9
Figure 4-10 Clearance at the Residential Point of Attachment	4-9
Figure 4-11 Clearance at the Residential Point of Attachment	4-9
Figure 4-12 Ground Clearances for Supply Service Drops, 0 Volts Through 750 Volts, Industrial and Commercial Installations (Required by the CPUC)	4-11
Figure 4-13 Clearances for Nonresidential Buildings Using Insulated Conductors (0 Volts–750 Volts)	4-13
Figure 4-14 Clearances for Nonresidential Buildings Using Insulated Conductors (0 Volts–750 Volts)	4-13
Figure 4-15 Clearances for Nonresidential Buildings Using Insulated Conductors (0 Volts–750 Volts))	4-13

Contents	Page
Section 4 Electric Service: Overhead, continued	
Figure 4-16 Clearances for Nonresidential Buildings Using Insulated Conductors (0 Volts–750 Volts))	4-13
Figure 4-17 Clearances for Nonresidential Buildings Using Insulated Conductors (0 Volts–750 Volts))	4-13
Figure 4-18 Clearances for Nonresidential Buildings Using Insulated Conductors (0 Volts–750 Volts)	4-13
Figure 4-19 Clearances for Nonresidential Buildings Using Insulated Conductors (0 Volts–750 Volts)	4-13
Figure 4-20 Clearances for Nonresidential Buildings Using Insulated Conductors (0 Volts–750 Volts)	4-13
Figure 4-21 Clearance Around Windows	4-14
Figure 4-22 Clearance Around Doors	4-14
Figure 4-23 Service Attachment Structure or Service Pole Secured to a Building	4-15
Figure 4-24 Service Pole Detached From a Building	4-15
Figure 4-25 Open Wire	4-16
Figure 4-26 Open Wire or Cable (Open Wire Shown)	4-16
Figure 4-27 Open Wire or Cable (Open Wire Shown)	4-16
Figure 4-28 Cable (Using Triplex)	4-16
Figure 4-29 Cable (Single Spool)	4-16
Figure 4-30 Open Wire or Cable (Cable Shown)	4-16

Contents	Page
Section 4 Electric Service: Overhead, continued	
Figure 4-31 Service Drop Cable, 4/0 and Smaller, Triplex or Quadruplex	4-18
Figure 4-32 New Wall, 1/0 kcmil to 397.5 kcmil Aluminum	4-18
Figure 4-33 New or Existing Wall, 1/0 kcmil to 397.5 kcmil Aluminum	4-18
Figure 4-34 Open Wire Service, #4 to 397.5 kcmil Aluminum	4-18
Figure 4-35 Service Drop Cable	4-18
Figure 4-36 Building Attachment–Service Knob	4-20
Figure 4-37 Self-Supported Periscope Attachment Structure	4-20
Figure 4-38 Braced Periscope Attachment Structure	4-20
Figure 4-39 Unbraced Periscope Structure (Residential and Nonresidential)	4-23
Figure 4-40 Illustration of 15-Foot Clearance, Low-Growth Zone	4-27
Figure 4-41 Grass and Shrubs Recommended Under Service Wires	4-27
Figure 4-42 Grass and Shrubs Recommended Under Transmission Wires	4-27
Figure 4-43 Alternative Routes to a House Showing High-Voltage Lines and Tree-Clearance Zones	4-28
Figure 4-44 Development Area	4-29
Figure 4-45 High-Voltage Marker on Poles and Crossarms	4-31
Section 5 Electric Metering: General	
Figure 5-1 Meter Cabinet Enclosure Clearances	5-10
Figure 5-2 Electric and Gas Meter Set Separation Dimensions and Clearances . .	5-11

Section 5 Electric Metering: General, continued

Figure 5-3	Semi-Flush Meter Installation	5-13
Figure 5-4	Enclosed Meter Installation	5-13
Figure 5-5	Preferred Location of Conduits for Indoor and Outdoor Meter Panels and Switchboards	5-14
Figure 5-6	Connection Diagrams for Self-Contained Meter Sockets	5-19
Figure 5-7	Connection Diagrams for Transformer-Rated Meter Sockets	5-19
Figure 5-8	Fire-Pump Equipment Location and Service Connection Options . . .	5-22
Figure 5-9	Circuit Breakers with Electronic Trip Unit	5-24
Figure 5-10	Single Meter With Main Service Switch	5-25
Figure 5-11	Single Meter With Multiple Service Switches	5-25
Figure 5-12	Multimeter Installation Without Main Disconnect Switch	5-25
Figure 5-13	Multimeter Installation With Main Disconnect Switch	5-25
Figure 5-14	Multiple Remote Switchboard or Meter Panel Locations	5-26
Figure 5-15	Grounding Outside of the Sealed Section–Self Contained Meter	5-28
Figure 5-16	Grounding Outside of the Sealed Section–Transformer Rated Meter .	5-28
Figure 5-17	Plug-In Temporary Service	5-29
Figure 5-18	Typical Plug-In Adapter	5-29
Figure 5-19	Temporary-Service Metering Pedestal	5-30
Figure 5-20	Transfer Switch	5-34

Contents	Page
Section 6 Electric Metering: Residential	
Figure 6-1	Residential Electric Metering Pedestal 6-2
Figure 6-2	Typical Underground Service-Termination Enclosure, Combination Meter-Socket Panel (Residential, 0 Amps–225 Amps) 6-5
Figure 6-3	Typical Service-Termination Enclosure, Combination Meter-Socket Panel for a Class 320 Meter (Residential, 120/240-Volt, 226-Amp Through 320-Amp Service) 6-6
Figure 6-4	Underground Combination Meter and Current-Transformer Cabinet (201 Amps–400 Amps, 1Ø or 3Ø) 6-8
Figure 6-5	Typical Underground, Separate-Bused, Current-Transformer Cabinet and Safety-Socket Meter Box Assembly, (201 Amps–400 Amps, 3Ø and 201 Amps–800 Amps, 1Ø) 6-8
Figure 6-6	Individual Meter Socket 6-9
Figure 6-7	Combination Meter Socket Load Center 6-9
Figure 6-8	Typical Service-Termination Enclosure, Combination Meter Socket Panel for a Class 320 Meter (Residential, 120/240-Volt, 226-Amp Through 320-Amp Service) 6-10
Figure 6-9	Overhead-Fed Combination Meter and Current-Transformer Cabinet, (201 Amps–400 Amps, 3Ø and 201 Amps–600 Amps, 1Ø) 6-11
Figure 6-10	Overhead-Fed, Separate-Bused, Current-Transformer Cabinet and Meter Box (201 Amps–400 Amps, 3Ø and 201 Amps–600 Amps, 1Ø) 6-12
Figure 6-11	1Meter Sockets With Wiring Gutters 6-13
Figure 6-12	Typical, Manufactured, Combination, Multimeter Installation: Seven Meters or More 6-15
Figure 6-13	Clearances for a Typical, Manufactured, Combination, Multimeter Installation 6-16

Contents	Page
Section 6 Electric Metering: Residential, continued	
Figure 6-14	Horizontal Meter Trough Installation: Six Meters or Less 6-17
Figure 6-15	Vertical Meter Trough Installation: Five Meters or Less 6-17
Section 7 Electric Metering: Commercial, Industrial, and Agricultural	
Figure 7-1	Bused, Safety-Socket Meter Box for Self-Contained Metering (0 Amps–100 Amps) 7-4
Figure 7-2	Bused, Safety-Socket Meter Box for Self-Contained Metering (101 Amps–200 Amps) 7-5
Figure 7-3	Underground Combination Meter and Current-Transformer Cabinet (201 Amps–400 Amps, 1Ø or 3Ø) 7-7
Figure 7-4	Separate-Bused Current-Transformer Cabinet and Meter Box With Underground Service-Termination Pull Box (201 Amps–400 Amps, 3Ø and 201 Amps–600 Amps, 1Ø) 7-8
Figure 7-5	Switchboard Pull Section 7-9
Figure 7-6	Separate Pull Box 7-9
Figure 7-7	Bottom-Fed Service Section 7-9
Figure 7-8	Overhead-Fed Combination Meter and Current-Transformer Cabinet, (201 Amps–400 Amps, 3Ø and 201 Amps–600 Amps, 1Ø) 7-11
Figure 7-9	Overhead-Fed, Separate-Bused, Current-Transformer Cabinet and Safety-Socket Meter Box (201 Amps–400 Amps, 3Ø, and 201 Amps–600 Amps, 1Ø) 7-12
Figure 7-10	Overhead, Service-Termination, Standard Switchboard Service Section (0 Volts–600 Volts) 7-13
Figure 7-11	Overhead Service, Grouped-Meter Installation Without a Main Switch 7-15

Contents	Page
Section 7 Electric Metering: Commercial, Industrial, and Agricultural, continued	
Figure 7-12 Underground Service, Grouped-Meter Installation Without a Main Switch	7-15
Figure 7-13 Grouped-Meter Installation With a Main	7-15
Section 9 Electric Metering: Components	
Figure 9-1 Test Blocks for Self-Contained Metering, 0 Amps–225 Amps	9-2
Figure 9-2 Removable Test Switch Mounting-Base Detail	9-2
Figure 9-3 Cabinet Showing Stud-Mounted Cover	9-3
Figure 9-4 Cabinet Showing Flanged Cover Fastened by Sealable Rivet Latches .	9-3
Figure 9-5 Cabinet Showing Hinged Front Cover	9-3
Figure 9-6 3-Wire, Single-Phase Service, Mounting Base	9-4
Figure 9-7 4-Wire, Three-Phase Service, Mounting Base	9-4
Figure 9-8 CT Mounting Base (Single-Phase or Three-Phase, 3-Wire, 201 Amps–600 Amps, 0 Volts–600 Volts)	9-5
Figure 9-9 Bused CT Cabinet, 3-Wire Service, 201 Amps–800 Amps	9-6
Figure 9-10 Bused CT Cabinet (4-Wire Service, 201 Amps–800 Amps)	9-7
Figure 9-11 Meter Box for Transformer-Rated Metering (Single-Phase or Three-Phase Installations)	9-8
Figure 9-12 Remote Metering Cabinet (Three-Phase Installations)	9-9
Figure 9-13 Typical Underground Service Termination Section and Pull Box, Wall-Mounted or Pad-Mounted (Floor-Standing)	9-12

Contents	Page
Section 9 Electric Metering: Components, continued	
Figure 9-14 Detail of Clearance Requirements for Adjacent Termination Bus Stubs	9-13
Figure 9-15 Detail of Aluminum, Termination Bus Stubs	9-13
Figure 9-16 Service-Terminal Conductor Connector	9-14
Figure 9-17 Cabinet Showing Stud-Mounted Cover	9-16
Figure 9-18 Cabinet Showing Flanged Cover Fastened by Sealable Rivet Latches	9-16
Figure 9-19 Cabinet Showing Hinged, Flanged Cover	9-16
Figure 9-20 Front View	9-19
Figure 9-21 Side View	9-19
Figure 9-22 Wireway Pull Section	9-19
Figure 9-23 Hinged Demand Reset Cover With Polycarbonate Viewing Window .	9-19
Figure 9-24 Utility Pull Section - Top View	9-19
Section 10 Electric Switchboards: 0 Volts Through 600 Volts	
Figure 10-1 Standard Switchboard, CT Compartment, 0 Amps–1,200 Amps, Single-Phase or Three-Phase, 3-Wire Service	10-7
Figure 10-2 Standard Switchboard, CT Compartment, 0 Amps–1,200 Amps, Three-Phase, 3-Wire and 4-Wire Services	10-8
Figure 10-3 Bus Drilling Detail	10-9
Figure 10-4 Standard Switchboard, CT Compartment, 1,001 Amps–3,000 Amps, Single-Phase or Three-Phase, 3-Wire Service	10-10

Contents	Page
Section 10 Electric Switchboards: 0 Volts Through 600 Volts, continued	
Figure 10-5 Standard Switchboard, CT Compartment, 1,001 Amps–3,000 Amps, Three-Phase, 4-Wire Service	10-12
Figure 10-6 Standard Switchboard, CT Compartment, 3,001 Amps and Larger, Three-Phase, 3-Wire Service	10-14
Figure 10-7 Standard Switchboard, CT Compartment, 3,001 Amps and Larger, Three-Phase, 3-Wire or 4-Wire Service	10-16
Figure 10-8 Switchboards, 0 Volts–600 Volts, CT Compartment, 1,001 Amps–3,000 Amps, Removable Link and CT Support (One-Bolt Configuration)	10-18
Figure 10-9 Switchboards, 0 Volts–600 Volts, CT Compartment, 1,001 Amps–3,000 Amps, Removable Link and CT Support (Four-Bolt Configuration)	10-19
Figure 10-10 Switchboards, 0 Volts–600 Volts, CT Compartment, 3,001 Amps and Larger, Removable Link and CT Support (Two-Bolt Configuration)	10-20
Figure 10-11 Switchboards, 0 Volts–600 Volts, CT Compartment, 3,001 Amps and Larger, Removable Link and CT Support (Six-Bolt Configuration)	10-21
Figure 10-12 Standard Section for Self-Contained Meter Sockets, 0 Amps–225 Amps, Installed in Switchboards: Nonresidential	10-23
Figure 10-13 Pull Section	10-25
Figure 10-14 Separate Pull Box	10-25
Figure 10-15 Bottom-Fed Service Section	10-25
Figure 10-16 Switchboard Pull Section, High Entry	10-27
Figure 10-17 Switchboard Pull Section, Low Entry	10-27

Contents	Page
Section 10 Electric Switchboards: 0 Volts Through 600 Volts, continued	
Figure 10-18 Extended Top on Switchboard Pull Section Front View (Side Entry) or Side View (Back Entry)	10-28
Figure 10-19 Additional Side or Back Switchboard Pull Section, High Entry	10-29
Figure 10-20 Additional Side or Back Switchboard Pull Section, Low Entry	10-30
Figure 10-21 Landing Terminal Detail	10-33
Figure 10-22 Spacing Requirements	10-33
Figure 10-23 Buses Accessible From Only One Side (Bolts Must Be Secured in Place)	10-33
Figure 10-24 Buses Accessible From Either Side (Mounting Surfaces on Both Sides of Bus)	10-33
Figure 10-25 Standard Switchboard Service Section With CT Compartment and Filler Panel, 0 Volts–600 Volts	10-35
Figure 10-26 Low-Profile Switchboard Service Section With CT Compartment for Underground, Outdoor Application, 0 Volts–600 Volts	10-36
Figure 10-27 Standard Switchboard Service Section, 15-Inch Hinged Panel for Socket Meter and Test Switch	10-37
Figure 10-28 Standard Switchboard Service Section, 30-Inch Panel for Socket Meters and Test Switches	10-38
Figure 10-29 Outdoor or Rain Tight Enclosures for Switchboards	10-39
Figure 10-30 Outdoor or Rain Tight Enclosures for Switchboards	10-39
Figure 10-31 Outdoor or Rain Tight Enclosures for Switchboards	10-39
Figure 10-32 Outdoor or Rain Tight Enclosures for Switchboards	10-39
Figure 10-33 Existing Switchboard	10-41

Contents	Page
Section 11 Electric Switchboards: 601 Volts Through 25,000 Volts and Primary Services	
Figure 11-1 Primary Switchboard Termination Section Pad Detail	11-4
Figure 11-2 Hinged Meter Panel with Multiple Sockets for 2,400 to 27,000 Volt Service	11-5
Figure 11-3 Hinged Meter Panel with Dual Socket for 2,400 to 27,000 Volt Service	11-6
Figure 11-4 Typical, High-Voltage Metering Enclosure: 2,400-Volt Through 17,000-Volt Service	11-8
Figure 11-5 Typical, High-Voltage Metering Enclosure, 17,001-Volt Through 25,000-Volt Service	11-9
Figure 11-6 Typical, High-Voltage Metering Enclosure, 17,001-Volt Through 25,000-Volt Service	11-10

This Page Intentionally Left Blank

SECTION 1 GENERAL

SECTION 1 GENERAL



Know what's below.
Call before you dig.

Section 1 General

Safety Alert

Contacting overhead or underground electric lines or equipment and natural gas pipelines can cause serious injury or death. Any part of a crane, scaffold, construction material, antenna, cable, rope, guy wire, or tool that touches an overhead electric line or penetrates an underground cable can become energized. Penetrating an underground natural gas line with a backhoe or other tool can cause a violent explosion.



WARNING

To avoid potential accidents, do not begin to excavate before identifying underground facilities.

State law requires applicants to contact [Underground Service Alert \(USA\)](#) by dialing 811 at least 2 working days before excavation (weekends and holidays excluded). Ensure that you call USA when planning underground work, before digging begins, to allow adequate time for USA to determine the location of underground gas and electric lines or equipment. *The potential for an accident exists if applicants fail to request USA to identify underground utility facilities before excavation begins.*

First, the applicant must mark the excavation area with white paint. Then, USA arranges for participating companies to mark the locations of their underground facilities at the jobsite. **This is a free service.** See the USA color-code identifiers below and on the back of this manual.

Additional information is available at www.pge.com/digsafely. Also, see USA services at the [USA North](http://www.usanorth.org) website at <http://www.usanorth.org>. USA is a locating service for excavation only. Do not use USA for design purposes.



USA



Dig Safely

Table 1-1 USA Color Coding¹

Excavation Sites & Underground Facilities	Marking Color
Proposed Excavation	White
Temporary Survey Markings	Pink
Electric	Red
Gas–Oil–Steam Chemical	Yellow
Communication CATV	Orange
Water	Blue
Reclaimed Water Irrigation Slurry	Purple
Sewer	Green

¹ Call 2 working days before you dig.

Arc-Flash Hazard Warning

All applicants or persons working on, working near, or observing others working on any PG&E facility **will be exposed** to potential arc-flash hazards and are required to wear flame-resistant (FR) clothing. The requirement to wear FR clothing applies to everyone. Applicants and their personnel must wear FR clothing before being allowed access to perform work in and around PG&E facilities. Also, applicants and their personnel must ensure that they wear the appropriate level of FR clothing for the job being performed. Please see [Appendix A](#), “Acronyms and Glossary,” for a definition of facilities. Also refer to the FR requirement letter in [Appendix B](#), “Electric and Gas Service Documents.”

1.1. Purpose

NOTE: For the purpose of this manual, the word “applicant” is used generically to refer to the Pacific Gas and Electric Company (PG&E) customer, or to the person or persons representing the PG&E customer in the application/construction process, including a contractor, design consultant, or installer. The word “customer” is used only when the word “applicant” is not applicable. Also, PG&E is sometimes referred to as the “Company” throughout this manual.

This manual is designed to help applicants establish gas and electric service. By reading the mandates published in this manual, applicants will understand not only the steps required to apply for service, but also the legal and safety requirements driving those steps. PG&E provides this manual to all gas and electric applicants, both in hard copy and online, in an effort to ensure that the Company can continue to deliver safe, uniform service.

The 2016 *Greenbook* supersedes all previous editions and revisions. This manual is a collection of requirements and policies for establishing electric and gas service to new or remodeled installations. The *Greenbook* is updated yearly; however, PG&E’s building requirements, as well as gas and electric design standards, are subject to change throughout the year. It is important that all applicants consult the online version of the *Greenbook* before finalizing project plans.

In addition to the requirements provided in this manual, applicants for gas or electric service also must comply with federal regulations and with all applicable [tariffs](#), as well as the rules and general orders set forth by the California Public Utilities Commission (CPUC). These regulations and orders include, but are not limited to, the following documents:

- [General Order \(G.O.\) 95](#), “Rules for Overhead Electric Line Construction”
- [G.O. 112-E](#), “Rules Governing Design, Construction, Testing, Operation, and Maintenance of Gas Gathering, Transmission, and Distribution Piping Systems”
- [G.O. 128](#), “Rules for Construction of Underground Electric Supply and Communication Systems”
- [49 Code of Federal Regulations \(CFR\)](#), Part 192, “Transportation of Natural and Other Gas by Pipeline: Minimum Federal Safety Standards”

Finally, applicants must comply with all other federal, state, and local regulations. These regulations may include a Federal Aviation Administration (FAA) review for structures that impinge on navigable airspace. In such cases, the FAA requires filing notice of proposed construction a **minimum of 45 days before starting the proposed construction**. The FAA may issue a determination of hazard to air navigation and recommend actions to mitigate or eliminate that hazard. For additional information, please contact your PG&E project coordinator.

1.2. Permits and Inspections

Builders who are constructing new buildings or remodeling existing buildings must conform to the following guidance documents.

- A. The current provisions of city and county ordinances.
- B. Rules on file with, or issued by, the CPUC.
- C. Applicable rules and laws of the state of California, including the following three codes.
 - Plumbing codes
 - Mechanical codes
 - Electric codes

Local and state ordinances require applicants to obtain the appropriate permits and final inspections before PG&E establishes services to any building or structure.

In areas where local ordinances governing gas or electrical installations do not exist, or where inspections provided by local jurisdictions for such installations are not available, the applicant must obtain written confirmation from a qualified person that the facilities meet the requirements specified in this manual.

PG&E will **not** establish gas or electric service until the gas piping or electric service facilities are installed satisfactorily.

NOTE: Gas meter release forms obtained from a permitting agency must include the specific, requested pressure (e.g., 7" w.c., 2 psig, 5 psig).

PG&E's inspection process includes service requirements that are **not** governed by local or state codes. Parts of the applicant's installation may require approval by state, local, **and PG&E inspectors**.

1.3. Applying for Building and Renovation Services

An "[Application for Service](#)" is required for all new gas or electric services, as well as for relocating or rearranging existing services. Whether you are building or renovating your home, expanding your business facility, or opening a facility at a new location, you can apply on the Internet at "Customer Connections Online" (www.pge.com/customerconnections) and track your project with our new online tools.



**Customer
Connect**



Customer
Connect

Also, at the PG&E Internet websites below, you will find guides for getting started, process overviews, project cost ranges, online applications, and more. This information is provided to help you plan your project and get started. For more information, visit the following web pages.

Residential Services: <http://www.pge.com/building>

Business and Agricultural Services: <http://www.pge.com/newconstruction>

Applicants without Internet access may contact the Building and Renovation Service Center 1-877-743-7782. PG&E representatives will provide you with details about the process and assist you with applying for service.

The process for installing or changing gas and electric services takes time and planning. PG&E recommends you contact us early in the process with accurate load information and the date that the services are required to allow for adequate time to complete your service request.

Large-capacity gas meters, electric transformers, or other special equipment often require **several months lead time** to ensure a timely delivery from the manufacturer.

Applicants must contact their local PG&E project coordinators when approved construction plans change, or when situations that affect PG&E's service arrangements occur during construction, so that mutually satisfactory, alternate arrangements can be made.

To assist PG&E in its goal to deliver safe, uniform service, applicants should **use the following guidelines when transmitting electronic drawing files for architectural, mechanical, and civil site plans.**

1. PG&E's electronic drawing tool is AutoCAD 2012, .DWG format. Ensure that submitted electronic drawings are either readable using, or compatible with, AutoCAD, 2012 (or older).

NOTE: PG&E accepts the version of AutoCAD with the "Pack & Go" feature.

2. Applicants can upload documents at PG&E's "Customer Connections Online" (www.pge.com/customerconnections) Internet website. Drawings also may be sent as an email-attached file.
3. Applicants who do not use the online option described in Number 2. above should send drawings for large projects in a zipped format.
4. Use layering, if possible, and preserve the layering when transferring files to PG&E.
5. Save all drawings in model space instead of paper space.
6. Make drawing plans two dimensional, with the "Z" elevation at zero.
7. Ensure that any External Reference Files (Xref) or drawing updates maintain a consistent insertion point.
8. Include all related drawing files (e.g., elevations, landscape plans, other proposed underground facilities).

Please contact your local PG&E project coordinator if you have any questions.



Residential



Commercial

PG&E is committed to complying with all federal, state, and local environmental laws, regulations, and rules. Applicants must provide PG&E with copies of permits showing that they have met all environmental compliance requirements when submitting applications for service. See the “[Applicant Responsibilities for Environmental Reviews for Service Requests](#)” letter for more information. **Applicants can obtain copies of this letter from their local PG&E project coordinators.**

Project permits or approvals may contain conditions that require or restrict certain service designs or construction activities by PG&E, applicants, agents, consultants, or contractors. The applicant must bring these conditions to PG&E’s attention to ensure that the requirements or restrictions are included in the project design during the planning and construction phases. When submitting the service application, the applicant **must** provide PG&E with a written copy of any special conditions, identifying the requirements or restrictions that affect the project design and/or PG&E installation activities.

1.4. Changes in Requirements

PG&E may revise its design and construction documents relating to applicant service requirements between updates to this manual. Except when required by law, the version of the design and construction document in effect on the date the applicant’s service design is approved and signed-off by the PG&E supervisor determines the requirements that the design must meet. These requirements apply as long as applicants complete approved projects within 12 months. If the applicant has not initiated construction within 12 months of PG&E’s initial approval, PG&E may initiate the review of the design and, if warranted, refresh the cost estimate. If the applicant does not fulfill obligations under the extension agreement, PG&E may, at its discretion, cancel the agreement (see Provisions Form 62-0982, Section 20). PG&E can then request another review of the design before approving construction activities.

For applicant design jobs, refer to the [Applicant Design Guide](#). On applicant design jobs, the version of the design and construction document that is in effect on the date PG&E approves and signs-off on the final Globals package determines the requirements that the design must meet. The Globals package is valid for 90 days.

Applicants are encouraged to contact PG&E **early in the planning stages** of their projects. By consulting with their local project coordinators, applicants are made aware of the current construction requirements **before** they initiate any design work.

Do not perform construction using an unauthorized or preliminary drawing. The applicant assumes full responsibility for errors, omissions, or changes if the project is constructed using either preliminary drawings or drawings that are not approved by PG&E.

PG&E will not accept or assume ownership of facilities installed by the applicant before the construction design is completed and approved by PG&E. Additional facilities, even if provided at no cost to PG&E, represent increased plant in the rate base. This includes associated, long-term increases in taxes and maintenance expenses. Applicants are responsible for any additional design changes or reconstruction costs that may be required if PG&E does not accept unapproved facilities. PG&E will not energize or pressurize a system that has not received final design approval and passed all inspections.

Engineering and construction documents or requirements are incorporated into new editions of this manual; however, revisions are made periodically. Applicants can obtain revised engineering documents or requirements in two ways:

- These documents are available on PG&E’s Internet site (www.pge.com/greenbook).
- These documents are available through your local PG&E project coordinators.

Some of the information contained in this manual is based on government codes and ordinances that are subject to change as determined by the governmental authorities. PG&E does **not** assume responsibility for keeping information in this manual current with these government codes, ordinances, or other requirements. Applicants should consult the responsible governmental agency with questions about the applicability of any construction procedures or requirements.

1.5. Additional Commercial and Industrial Service Information

For electric installations of more than 600 volts (V), refer to *Greenbook* Section 11, “Electric Switchboards: 601 Volts Through 25,000 Volts and Primary Services.” Generally, this manual does **not** include information about large commercial or industrial gas loads; however, PG&E provides applicants with individual job-design specifications after they request service.

1.6. Design and Construction

1.6.1. PG&E’s Responsibilities

PG&E is responsible for planning, designing, and engineering its service facilities and service laterals using PG&E’s standards for design, materials, and construction.

1.6.2. Applicant’s Responsibilities

Residential and nonresidential industrial applicants for gas and/or electric extensions and services may select a contractor to design their facilities.

PG&E requires a clear path from existing distribution facilities to the location on the applicant’s jobsite where the services will be connected. Depending on the project, the applicant may need permits or approvals for these supply lines in order to comply with federal, state, and local requirements, regulations, and rules (including environmental laws).

Local PG&E project coordinators can provide applicants with information about available options for clearing supply lines, as well as any associated design and contract requirements for their projects.

Before designing their projects, applicants and/or their contractors must complete PG&E’s [“Application for Service”](#) form, provide applicable construction plans, and submit any required project deposits to PG&E.

1.6.3. Providing Access to PG&E Electric Facilities

Applicants are required to provide access roads on their properties to PG&E pad-mounted or subsurface (i.e., transformer or switch) facilities. The roads must be accessible to PG&E at all times and constructed with either a Class 2 or an AB road base that is a minimum of 10 feet wide, with 18 feet of vertical clearance above. Also, there must be a 30-foot radial, hammerhead-style, turn-around area at the end of the roads.

Do not place facilities more than 15 feet away from an accessible road.

1.6.4. Installing Transformers

PG&E will specify the type of transformer installations to be constructed on applicants' premises.

Applicants may contact their local PG&E project coordinators to obtain specific transformer requirements for their projects.

NOTE: For reasons of safety and reliability, PG&E does not allow applicants to install water sprinklers to cool off transformers.

PG&E's standard transformer installations for residential, commercial, and industrial services are described below:

- A. A pole-bolted transformer in overhead areas when the applicant's load does **not** require a 75 kilovolt ampere (kVA) or larger transformer.
- B. A pad-mounted transformer in underground areas or in an area with overhead facilities when PG&E determines that the applicant's load requires a 75 kVA or larger transformer.

1.7. Connecting and Sealing Services

A. PG&E provides standard service to applicants as described below.

1. Establish service at one service delivery point, through one meter, and at one voltage class or pressure.
2. Design service to extend from the connection to the distribution facilities along the shortest, most practical, and most available route to the service termination facility or service delivery point, as determined by PG&E.

B. The requirements for standard service are described below.

1. Only authorized PG&E employees can connect or disconnect PG&E's gas or electric service to the building or structure.
2. Unauthorized persons must not tamper with or break PG&E seals placed on meters and associated service equipment.
3. Only authorized PG&E employees can remove, replace, or interfere with PG&E's meters, seals, connections, padlocks, or other locking devices.
4. Applicants must call PG&E if it is necessary to have either the service disconnected or the meter removed because of remodeling, alterations, or other activities.

5. Applicants must **not** connect house gas pipes or other applicant facilities to the plugged side of the gas service-tee fitting. That fitting is for PG&E's use only.
6. Applicants must place service termination enclosures in PG&E-approved locations within buildings, such as meter and service rooms or similar areas.
7. Applicants must **not** locate service termination enclosures in the interior, inhabitable area of residences.
8. Applicants must ensure that all service and metering facilities are readily accessible.
9. PG&E must review and approve of all service and meter locations and arrangements **before installing** any metering facilities, service-termination enclosures, or other utility service facilities.
10. The applicant assumes the risk for any work performed without requesting PG&E's advanced approval. PG&E can charge the applicant if it is necessary to make changes to unapproved work.
11. An unauthorized connection to PG&E's gas or electric facilities, or to facilities used to provide utility services, may be a violation of the [California Penal Code, Section 498](#) and [Section 593c](#), and subject the person to damages pursuant to [California Civil Code, Section 1882](#), et. Sequitur. These sections address connecting to utility meters and facilities and diverting utility services. They specifically prohibit any person from tampering with, making, or causing to be made any connection or reconnection with property owned or used by the utility to provide utility service, without the utility's authorization or consent.
12. PG&E may require a service location to be closer to the distribution facilities in the following instances:
 - In areas where the nearest building is a considerable distance (i.e., 200 feet or more) from the property line.
 - If, in PG&E's judgment, there is a potential hazard between the property line and service location.

1.8. Access to an Applicant's Residence, Building, or Property

PG&E has the right to access Company facilities located on an applicant's premises at any time, for any purpose connected with furnishing gas and/or electric service. These purposes include the following activities:

- Reading meters.
- Inspecting utility facilities.
- Making routine repairs.
- Performing maintenance and emergency work.
- Exercising any and all rights secured to PG&E either by law or under PG&E's tariff schedules, including [Electric Rule 16](#), "Service Extensions," and [Gas Rule 16](#), "Gas Service Extensions."

1.9. Overhead Electric Lines

The [California Division of Occupational Safety and Health \(Cal/OSHA\) regulations, Title 8](#), Division 1, “Department of Industrial Relations,” Chapter 4, “Division of Industrial Safety,” Subchapter 4, “Construction Safety Orders,” [Article 15, “Cranes and Derricks in Construction,” Section 1612, “Power Line Safety,”](#) and the associated sub-articles, require that minimum safe working and traveling distances be maintained from cranes and derricks to overhead electric lines.

In support of these regulations, PG&E provides the voltage for overhead lines within two business days of receiving a customer inquiry. Call the PG&E Building and Renovation Service Center (BRSC) at 877-743-7782 or Customer Service at 1-800-743-5000.

[Cal/OSHA regulations, Title 8](#), Chapter 4, Subchapter 5, “Electrical Safety Orders,” Group 2, “High-Voltage Electrical Safety Orders,” Article 37, “Provisions for Preventing Accidents Due to Proximity to Overhead Lines (Formerly Article 86),” [Section 2946, “Provisions for Preventing Accidents Due to Proximity to Overhead Lines,”](#) requires that minimum safe working distances be maintained from overhead electric lines. Specific requirements taken from the regulation are shown in Table 1-2, “Minimum Safe Working Distances (Scaffolds, Equipment, Tools, Structures, and People),” and Table 1-3, “Minimum Safe Working Distances (Boom-Type Lifting or Hoisting Equipment),” both below.

Table 1-2 Minimum Safe Working Distances (Scaffolds, Equipment, Tools, Structures, and People)

Nominal Voltage (Phase-to-Phase)	Minimum Required Clearance (Feet)
600 — 50,000	6
over 50,000 — 345,000	10
over 345,000 — 750,000	16
over 750,000 — 1,000,000	20

Table 1-3 Minimum Safe Working Distances (Boom-Type Lifting or Hoisting Equipment)

Nominal Voltage (Phase-to-Phase)	Minimum Required Clearance (Feet)
600 — 50,000	10
over 50,000 — 75,000	11
over 75,000 — 125,000	13
over 125,000 — 175,000	15
over 175,000 — 250,000	17
over 250,000 — 370,000	21
over 370,000 — 550,000	27
over 550,000 — 1,000,000	42

Contact a local PG&E project coordinator with any questions about working near overhead electric lines or about nominal voltage.

1.10. Underground Electric Lines and Gas Pipelines



Safety

As mentioned on Page 1-1, state law requires applicants to contact [USA](#) by dialing 811 at least 2 working days before excavation (weekends and holidays excluded). Applicants **must** call USA when *planning* underground work (**before digging begins**) to allow adequate time for USA to determine the locations of underground gas and electric lines and/or equipment.



USA

USA arranges for participating companies to mark the locations of their underground facilities at the jobsite. There is no charge for this service. The applicant must mark each end of the excavation area with white paint as well as the total length in feet. Applicants should also use arrows to indicate the direction of the trench. For more information, go to www.pge.com/digsafely. Also, learn more about USA services at the USA North website (<http://www.usanorth.org>).

When any new vegetation is planted, ensure that a **minimum of 5 feet** is maintained from underground gas utilities. Please refer to PG&E's [Guide to Safe Landscaping Near Gas Pipelines](#) for helpful information about the types of trees and plants that are safe for areas near gas pipelines.



Dig Safely

1.11. PG&E Safety Training Resources

PG&E wants to ensure that contractors and construction workers avoid electric and natural gas hazards by practicing basic safety rules. Please visit www.pge.com/contractorsafety, “Contractor Safety Program Contract Requirements,” for materials to assist you in providing your employees with safety training.

1.12. SmartMeter™ Program



SmartMeter™

PG&E's SmartMeter™ Program is part of a statewide effort driven by the CPUC to upgrade California's energy infrastructure with automated metering technology. The SmartMeter™ Advanced Meter Reading system includes a programmable, solid-state electric meter and a gas module, installed on a traditional gas meter at each service delivery point to measure and record energy use.

For more information on SmartMeters™, including instructions on tracking your energy use online or information on the opt-out program, please visit www.pge.com/smartmeter.

1.13. PG&E Online (Website)

The PG&E website at www.pge.com has many tools for building or renovating your home, expanding or renovating your business facility, or opening a new location.

Building and Renovation Services tools are available for residential services at www.pge.com/building/, and for business services at www.pge.com/newconstruction. These websites include:

- “Getting Started” guides.
- Glossary of terms.
- Building and renovation services process flow.
- A tool to locate city/county building and planning departments.
- A project cost range tool.
- Answers to frequently asked questions (FAQs).
- A link to energy-efficiency rebate information.

These tools can help you plan your project and get started. For more information, visit the following web pages.

- Apply online and track your project: www.pge.com/customerconnections
- Residential services: www.pge.com/building/
- Business and agricultural services: www.pge.com/newconstruction



Commercial



Residential

1.13.1. *Electric and Gas Service Requirements Manual (aka Greenbook)*

The *Greenbook* is available on the Internet at www.pge.com/greenbook. Perform the following steps to access the *Greenbook* from the [PG&E homepage](http://www.pge.com) (<http://www.pge.com/>).

- A. Select either the “[For My Home](#)” or the “[For My Business](#)” link on the [PG&E homepage](#).
- B. Find the “Customer Service” drop-down at the top of the page and click on “More Services.”
- C. Click on the “[Building and Renovation Services](#)” link in the middle of the page.
- D. On the right side, under “Additional Resources,” find the *Electric and Gas Service Requirements* link.

NOTE: Communicate and coordinate all gas and electric service arrangements through your assigned PG&E project coordinator. As mentioned earlier in this section, PG&E documents may be updated independently of this manual; however, the project coordinators provide applicants with the latest updated or revised information on request. Applicants **must** contact their assigned project coordinators to ensure that they are correctly interpreting and using the information found in this manual and in other governing documents.



Customer
Connect



Rates & Tariffs

1.13.2. Rates and Tariffs

Rate and tariff information is available on the “Rates and Tariffs Library” at <http://www.pge.com/about/rates/>. This information also is available under the “Additional Resources” heading on the “[Building and Renovation Services](#)” homepage. The online “[Tariffs](#)” provide current gas and electric rate schedules, preliminary statements, rules, forms, advice letters, and more.

1.14. Determining the Service Rating

- A. For installations supplying a single main-disconnecting means (i.e., single main disconnect), the rating of the PG&E service to be supplied is the rating of the electrical enclosure, service-termination section, pull can, service section, main service-switch continuous current rating, or other service-termination enclosure where PG&E terminates and connects its supply facilities and conductors (**whichever is greater**).

For switchboards, this is typically listed as the supply rating. For panelboards, the rating is the maximum ampacity or the greatest rating for any individual component (main bus, meter socket, main disconnect, etc.) in the panelboard. See exceptions for select agricultural customers in Subsection 1.14.D. below.

- B. For installations supplying a premises without a single disconnecting means (e.g., a service with multiple disconnects), the rating of the PG&E service to be supplied is the rating of the electrical enclosure, service-termination section, pull can, service section, or other service-termination enclosure where PG&E terminates and connects its supply facilities and conductors (**whichever is greater**). For switchboards, this is typically listed as the supply rating. For panelboards, the rating is the maximum ampacity or the greatest rating for any individual component (main bus, meter socket, etc.) in the panelboard. See exceptions for select agricultural customers in Subsection 1.14.D. below.
- C. If the termination section, enclosure, or facility is **not** rated, the rating of the service is the maximum rating of the single, main-disconnecting means or the aggregated maximum ratings of all the service disconnects. See exceptions for select agricultural customers in Subsection 1.14.D. below.
- D. For agricultural services with a pump motor as the largest load, the ampacity rating of either single or multiple main-service disconnects is no longer used to determine the PG&E service rating for metering equipment that requires transformer-rated meter(s) and current transformers (CTs). The rating of the service supplied will be the ampacity rating of the metering equipment or enclosure (typically whichever is greater) where the service conductors terminate. This exception applies only to the following equipment.
- Wall-mounted (includes panelboard construction) metering equipment or termination enclosure, without a breaker or fused disconnects, located inside of the enclosure. The breaker or disconnects must be located in a separate enclosure.
 - Pad-mounted (i.e., floor-standing) equipment, with or without a breaker or fused disconnects, located inside of the enclosure.

This exception is not applicable when self-contained metering equipment is installed.

1.15. Changing an Applicant's Approved Project or Existing Service Loads

An applicant **must provide written notice to PG&E** of any changes or plans to make material changes either in the amount or in the character of the gas and/or electrical load, equipment, or other facilities installed to supply gas and/or electricity to the applicant's premises, structure, building, or other facilities. For more information, applicants can review [Electric Rule 2](#) and [Gas Rule 2](#), both called "Description of Service," as well as [Electric Rule 3](#) and [Gas Rule 3](#), both called "Application for Service." PG&E requires this written information to determine the following factors.

1. The adequacy of the existing utility service and supply facilities.
2. The need to modify those facilities to meet and supply the changed load or equipment requirements. This includes changes in the character or nature of the applicant's previously approved gas and/or electric service.

Applicants must notify PG&E of any planned or intended changes in the load, character, or nature of the service required to supply the premises, structure, building, or other facilities.

If an applicant fails to notify PG&E, and the changes exceed the capabilities of the installed utility service, metering, or other equipment and damage those facilities, the applicant is liable for all damages and resultant costs to PG&E.

Applicants must provide PG&E with written notice **immediately** when they make any material change either in the amount or character of the gas and electric lamps, appliances, or apparatus installed on the premises to be supplied with electric energy.

1.15.1. Upgrading, Replacing, Relocating Electric Facilities, or Adding Power Generation Sources

When PG&E determines that its existing service facilities require replacement, those facilities are replaced as a new service extension under the provisions of the tariff rules.

Upgrade: An increase in the ampacity rating (e.g., 100 amps to 125 amps) of the equipment where PG&E terminates its service is typically defined as an upgrade. The ampacity rating also may be known as the service-entrance capacity. For example, when an applicant replaces an existing electric meter panel, switchboard, or termination enclosure with one that has a greater ampacity rating (i.e., upgrade), all *Greenbook* requirements must be met. Typically, this also includes installing new conduit and service conductors. See the sections titled "Upgraded Panel" in the numbered documents below for conditions when the conduit or cable may not require upgrading, as determined by PG&E.

- [Numbered Document 063927](#), "Methods and Requirements for Installing Residential Underground Electric Services 0–600 V to Customer-Owned Facilities"
- [Numbered Document 063928](#), "Methods and Requirements for Installing Commercial Underground Electric Services 0–600 Volts to Customer-Owned Facilities"

Like-for-Like: Replacing service equipment with equipment of the exact same ampacity (e.g., 100 amps to 100 amps) is considered a “like-for-like” replacement and typically is **not** considered an upgrade.

The service equipment must be positioned so the existing PG&E service conductors can be reconnected properly. If PG&E needs to install additional service conductors or cables to perform the reconnect, the work and material is the applicant’s responsibility. (See the paragraph on “Relocating” below.) A like-for-like does not have to meet the current *Greenbook* requirements if the safety or accessibility of the panel location is not compromised. For example, structures (e.g., decks, remodeled buildings) built over or around existing panels may not be energized if they do not meet PG&E requirements for safe working conditions.

Relocating: When existing electric facilities are relocated, applicant’s must meet all of the current *Greenbook* requirements. If PG&E’s existing service conductor can be used, as determined by PG&E, the panel must be positioned so the service conductor can be reconnected properly. The existing service conductor must be able to be reconnected either to the underground electric panel termination lugs or, for overhead services, to the external service-entrance conductors coming out of the weatherhead. If PG&E needs to install additional service conductors or cables to perform the reconnect, the work and material is the applicant’s responsibility. PG&E **does not accept** cable-termination techniques using pin adaptors, cable ringing, or splicing on additional cable.

For additional information, see Subsection 5.3., “Electric Meters: General Location Requirements,” on Page 5-5.

Adding Power Generation: All customer-generating equipment connected either to the Company’s equipment or to customer equipment must conform to Company standards. This includes any applicable municipal, local, city, or federal rules and regulations, unless otherwise specified. Any distributed generation (DG) facilities must meet the clearance requirements detailed in the *Greenbook*. This includes all clearance requirements from gas facilities. Examples of DG facilities include, but are not limited to, renewable sources such as solar, wind, water power, and farm waste, as well as nonrenewable energy sources such as natural gas or other fossil fuels for conventional engines, turbines, and fuel cells.

1.16. Standard Residential Service Voltage

This subsection clarifies PG&E’s voltage requirements when applicants design residential services.

1.16.1. Single-Phase Service

Unless the applicant qualifies for a three-phase service, the service voltage for single-family residential homes, duplex homes, town homes, condominiums, or apartment buildings is **120/240 V, single phase**.

PG&E will **not** supply 120/208 V, single-phase service to residential structures or buildings unless **both** of the following conditions are met.

- A. A 120/208 V secondary system is established near the location where the requested service would be supplied.
- B. The rating of the disconnecting means (i.e., the main switch or main disconnect) or of the service entrance does **not** exceed 225 amperes.

1.16.2. Three-Phase Service

If PG&E determines that a **single** residential building or structure justifies a 75 kVA transformer at 120/208 V, or a 5 horsepower or larger motor at 120/240 V for an overhead service, then installing three-phase service is an **option** for the applicant. This option also is available for underground services with a 75 kVA transformer at 120/208 V, or a 10 horsepower or larger motor at 120/240 V.

This applies whether the applicant plans to wire the individual residential units in a single-phase or a three-phase configuration. Applicants requesting the three-phase option must provide space on the property for PG&E to install a dedicated transformer. For more information, see [Electric Rule 2](#).

If, based solely on PG&E's estimation, the electric service demand is greater than that which can be supplied by a single-phase, 100 kVA transformer, then PG&E **must** supply three-phase service.

Other load limitations and requirements used to determine qualification for three-phase service are contained in PG&E's [Electric Rule 2](#).

Three-phase service is available in 208Y/120, 240/120, or 480Y/277 voltages. The appropriate voltage depends on the minimum load requirements and the maximum demand load permitted by PG&E's [Electric Rule 2](#).

1.16.3. Mixed-Use Projects

Mixed-use projects include both commercial and residential loads. When designing a mixed-use project where the use occurs in separate buildings, ensure that each facility is supplied by a separate transformer. This means that a three-phase transformer could supply the commercial unit(s) and a single-phase transformer could supply the residential units(s).

If the mixed-use occurs in the same building, a single transformer typically is installed to supply the building. **The size and selection of the transformer is based solely on PG&E's estimated demand load.** The applicant must provide space on the property for PG&E to install a dedicated transformer.

In some cases, PG&E may determine that the commercial and residential loads must be supplied by separate transformers and service facilities, including meters and metering facilities. PG&E makes this determination based on the nature or anticipated operation of the nonresidential loads and how they may affect the services. The applicant must provide space for those service facilities on the property.

Again, when developing mixed-use projects, the applicant must communicate and work closely with PG&E early in the design phase.

This Page Intentionally Left Blank

SECTION 2 GAS SERVICE

SECTION 2 GAS SERVICE

Section 2 Gas Service



Know what's below.
Call before you dig.

2.1. Scope

This section of the manual covers general gas service and gas meter-set requirements for residential and nonresidential installations.



USA



WARNING

To avoid potential accidents, do NOT begin to excavate before identifying underground facilities.

State law requires applicants to contact [Underground Service Alert \(USA\)](#) by **dialing 811 at least 2 working days before excavation** (weekends and holidays excluded). Ensure that you call USA when planning underground work, before digging begins, to allow adequate time for USA to determine the location of underground gas and electric lines or equipment. *The potential for an accident exists if applicants fail to request USA to identify underground utility facilities before they begin excavating.*

First, the applicant must mark the excavation area with white paint. Then, USA arranges for participating companies to mark the locations of their underground facilities at the jobsite. **This is a free service.** See the USA color-code identifiers in Table 1-1, “USA Color Coding,” on Page 1-1, and on the back of this manual.

Additional information is available at <http://www.pge.com/digsafely>. Find USA services at the USA North website (<http://www.usanorth.org>). USA is a locating service for excavation only. Do not use USA for design purposes.



Dig Safely

2.2. Procedures for Establishing Gas Service

2.2.1. Establishing New Gas Service

Applicants must follow the steps described below to establish new gas service.

A. Applicant’s Planning Stage

When planning to establish new gas service, applicants must:

1. Fill out and submit the appropriate PG&E application. Refer to Subsection 1.3., “Applying for Building and Renovation Services,” on Page 1-3, for more information about the application requirements.
2. Contact their local PG&E project coordinators as early in the planning stage as possible.

NOTE: See [Table FM-1, “Service Planning Office Contact Information,”](#) at the front of this manual starting on Page iv, for specific contact numbers listed by area.

B. Working With PG&E

After initially contacting PG&E about installing new gas service, applicants must:

1. Provide detailed site improvement plans indicating roads, sidewalks, and driveways, as well as the locations of other site infrastructure elements. For individual parcels/single buildings, include the proposed locations of gas and electric meters, building elevations, and proposed future improvements. Ensure that the written details for required clearances in meter set assemblies are also included in the drawing. (Meter locations are subject to PG&E approval.)
2. Submit details about the type(s) of gas appliances being installed per meter. Include the connected load breakdown in thousand British Thermal Units (MBTU) per hour for each appliance and its intended use.
3. Applicants requesting more than the standard delivery pressure of 7 inches of water column (WC) must submit a written justification for PG&E's review and approval. Standard delivery pressure is approximately 1/4 pounds per square inch gauge (psig). See Subsection 2.4.1., "Gas Pressure," on Page 2-19, for more requirements.
4. Applicants can choose either PG&E or an outside company to design and/or install their services. PG&E provides the applicant with a bid for service design and installation costs. Specific conditions must be met whether the applicant chooses PG&E or an outside company to work on the project. PG&E Standard S5453, "Joint Trench," located in [Appendix B](#), "Electric and Gas Service Documents." PG&E Standard S5453, Exhibit A, "Joint Trench Drawing," and Exhibit E, "Authorization for Joint Trench Construction, Form B," both are required when PG&E facilities are in a trench with other utilities. Contact your local project coordinator for copies of these documents. (See [Table FM-1, "Service Planning Office Contact Information,"](#) starting on Page iv.)

Do not perform construction using an unauthorized or preliminary drawing. The applicant assumes full responsibility for errors, omissions, or changes if the project is constructed using either preliminary drawings or drawings that are not approved by PG&E.

PG&E will not accept or assume ownership of additional facilities installed where the applicant begins construction before the design is completed and approved by PG&E. Additional facilities, even if provided at no cost to PG&E, represent increased plant in the rate base. This includes associated, long-term increases in taxes and maintenance expenses.

Applicants are responsible for any additional design changes or reconstruction costs that may be required if PG&E does not accept unapproved facilities. PG&E will not pressurize a system that has not received final design approval and passed all inspections.

Information about service design and installation options is available either on [Form 79-716, “General Terms and Conditions for Gas and Electric Extension and Service Construction by Applicant.”](#) or by calling PG&E’s Building and Renovation Service Center (BRSC) at 877-743-7782.

5. Obtain approval from PG&E’s project coordinators for the gas service lateral and meter-set location. If the new gas service request is complex, PG&E may require that estimators and/or engineers become involved **before** approving the gas service lateral and meter-set location.
6. Select a trenching agent to perform the required trenching and paving services. The trenching agent also must obtain all of the permits required for installing the gas service pipe from the point of connection at the main to the approved meter location. Applicants can select either PG&E or an outside contractor to perform this work.

If an applicant selects an outside trenching agent for the project, the applicant must obtain a copy of PG&E’s approved trench route or construction sketch. PG&E must inspect and approve any trenching and paving work performed by outside agents.

7. Pay PG&E for all of the installation costs. This includes the costs for facilities and appurtenant fittings, valves, service pipe, service regulators, metering equipment, etc., in excess of the allowances. For more information, see PG&E’s [Gas Rule 15](#), “Gas Main Extensions,” Section B, “Installation Responsibilities,” and [Gas Rule 16](#), “Gas Service Extensions,” Section E, “Allowances and Payments by Applicant.”
8. Install, own, and maintain physical protection such as bollards or barrier posts and/or enclosures, as may be required.

C. Complying with Local Building Laws and Regulations

Applicants must contact local city and county deputies and inspectors to ensure compliance with all local laws and regulations. Applicants must:

1. Allow only qualified professionals to install applicant-owned facilities. Also, applicants must ensure that equipment required by local building codes are inspected by local building inspectors.
2. Complete the required inspections on applicant-installed gas piping (e.g., houselines) and equipment (e.g., valves, appliances) **before** scheduling meter-set work with PG&E.

2.2.2. Relocating or Adding Load to an *Existing* Service

An applicant should contact PG&E as early as possible when he or she plans either to build an addition on an existing premises or to relocate an existing service to a different, acceptable location. Applicants are required to fill out and submit [PG&E Form 62-0687, “Application for Service–Existing Service Relocate/Change Service.”](#) This form is located on pge.com at

http://www.pge.com/tariffs/tm2/pdf/GAS_FORMS_62-0687.pdf.

This form, along with additional information about building and renovation services, also is found at <http://www.pge.com/building/>.

The form requires applicants to provide the following information.

- **Project Type:** Asks the reason for the relocation/rearrangement.
- **Project Information:** Asks specific information about the project location and applicant.
- **Contract Information:** Asks for the applicant’s legal name, mailing address, etc.
- **Representative Information:** If the applicant has a legal representative to relay project information and updates to the PG&E representative, the legal representative’s name goes here.
- **Construction Information:** Describes the applicant’s choices for trenching and backfill work.
- **Load Information:** Asks for the number of existing meters at each service location. Provide details about the types of existing gas appliances, as well as those being installed. Include the connected load breakdown in thousand British Thermal Units (MBTU) per hour for each appliance. Also include a description of each appliance’s intended use.
- **Self-Generation and Net Metering Options:** Describes the requirements to apply for PG&E’s net metering program.
- **Attachments:** Lists the documents required for the application including site improvement plans, drawings, and maps.
- **Agreement to Pay and Signature:** Applicants must sign the agreement and pay any fees associated with the work.

NOTE: Adding load may cause the existing service to become inadequate and may require the service to be upgraded and or replaced at the applicant’s expense. (See [Gas Rule 16](#).)

Applicants can choose to provide trenching for gas services relocations. [PG&E Form 62-0687](#) describes these options in greater detail.

2.3. Gas Service Lateral

All plastic gas distribution service pipes and stub completions must be a minimum diameter of 1 inch for all new business installations and customer-requested service relocations.



Gas App.

2.3.1. General

A gas service lateral is the section of plastic tubing or steel pipe that connects the service riser and gas meter to PG&E's gas distribution main. The gas distribution main usually is located in the street or in an easement located adjacent to the applicant being served. For an example, see Figure 2-1, "Typical Gas Service Installation," on Page 2-6.

Applicants should install the gas distribution mains in joint trenches, when it is feasible to do so. Locate distribution mains 10 feet from the face or foundation of any building as described in [Gas Design Standard A-90](#) "Polyethylene Gas Distribution System Design," located in [Appendix C](#), "Electric and Gas Engineering Documents." On private property, ensure that easements are at least 10 feet wide for mains. Services that cross third-party property also require a 10-foot wide easement.

A financial allowance for the installed service cost is based on the applicable, connected gas appliances installed within a specific time period. The allowance is applied toward the cost of a new service, as outlined in PG&E [Gas Rule 16](#), Section E.

A. When installing a gas service lateral service, PG&E performs the following actions.

NOTE: While it is PG&E's responsibility to install and design the gas service lateral, the applicant has the **option** to perform both.

1. PG&E installs a service-lateral extension and applies the gas rule allowances, based on applicant load, to the applicant under the following conditions:
 - a. PG&E determines that the loads to be served are bona fide.
 - b. The loads are connected and the extension placed into service subject to compliance with [Gas Rule 15](#) and [Gas Rule 16](#).
2. Design the PG&E-approved gas service to the shortest and most practical route, preferably in a straight line at a right angle from the gas main to an approved meter location. Avoid offsets, diagonal runs, bends, and services installed under driveways or customer-paved areas. **Exceptions require PG&E's advanced approval.** When the building or structure is on a corner lot, PG&E determines the gas main for connection.
3. Install and connect the gas service lateral to the gas main in the adjoining street, highway, alley, lane, road, or easement.

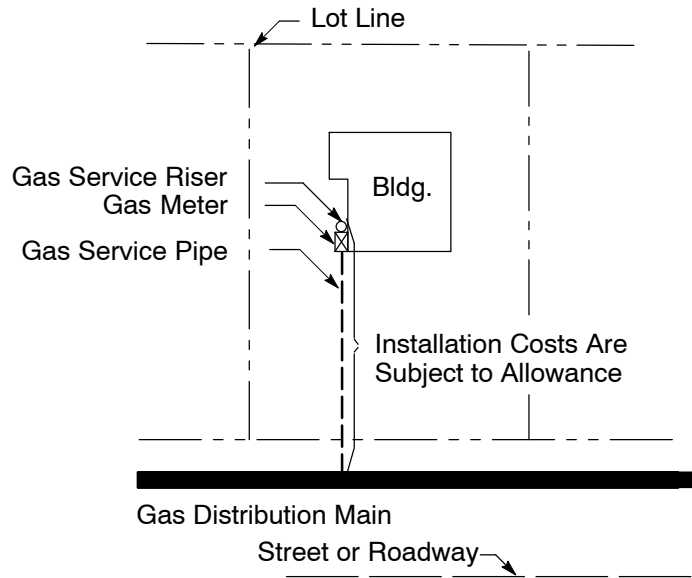

**Figure 2-1
Typical Gas Service Installation**

4. Install a utility excess flow valve (EFV), as required, when installing a new service lateral. See Subsection 2.3.1.D. on Page 2-8 for more information on installing EFVs. For specific requirements, refer to [Gas Design Standard A-93.3](#), “Excess Flow Valves,” located in [Appendix C](#).
5. Own and maintain the gas service lateral (and EFV, if required) from its point of connection with the gas main to the service delivery point.
6. If possible, do not install gas service laterals under or through retaining structures (e.g., retaining walls) greater than 3 feet tall. PG&E will consider plans that include service laterals running under or through retaining structures and determine approval on a case-by-case basis.

NOTE: A **retaining wall** is a structure that retains (i.e., holds back) material (usually earth) and prevents it from sliding or eroding away. Retaining walls are designed to resist the pressure of the material being held back.

B. PG&E does *not* permit the following types of installations.

1. Installing gas service laterals under or through structures, buildings, foundations, or decks. On an exception basis, PG&E may approve a gas service riser in a gas meter room that meets the requirements in [Gas Design Standard J-16](#), “Gas Meter Room,” located in [Appendix C](#).
2. Installing gas service laterals and gas service risers directly into concrete or asphalt pavement materials.

3. Installing gas service risers that are not approved by PG&E.
4. Installing gas service risers without an approved sun shield.

NOTE: If PG&E determines that an applicant's uninspected trench excavation requires repair, or if the uninspected trench is backfilled and/or paved over, the applicant must provide and pay for all of the paving services and permits that are required to get an inspection and repair the trench excavation completely. This includes trenches dug on both public and private property.

- C. When installing a gas service lateral, the applicant is responsible for ensuring the following conditions are met.

NOTE: Applicants must refer to [PG&E Form 79-716, "General Terms and Conditions for Gas and Electric Extension and Service Construction by Applicant,"](#) when they propose installing new gas services for new business utility services. This form is located on the [Tariffs](#) website on [pge.com](#) at http://www.pge.com/tariffs/tm2/pdf/GAS_FORMS_79-716.pdf.

1. Provide and maintain a clear route, free of any obstructions, for installing the gas service facilities.
2. Trench, backfill, and perform any other digging as described in PG&E's specification and inspection instructions, as required.
3. Pay any required permit fees.
4. Install and maintain all of the gas piping downstream of the service delivery point. See Subsection 2.5., "Applicant-Owned and Installed Gas-Service Piping (e.g., Housetline), Valves, and Automatic Shut-Off Devices," on Page 2-43, for more information.
5. Ensure that all requirements are met in the following PG&E Gas Design Standards, located in [Appendix C](#).
 - [A-75, "Gas Service and Mains in Plastic Casing"](#)
 - [A-81, "Plugs and Caps for Non-Pressurized Gas Pipelines"](#)
 - [A-90, "Polyethylene Gas Distribution System Design"](#)
 - [A-93.1, "Installing and Maintaining a Polyethylene Gas Distribution System"](#)
 - [A-93.3, "Excess Flow Valves"](#)
6. Notify PG&E as soon as any paving activity is planned and provide PG&E with the scheduled completion date. Applicants should remember that PG&E can meet their schedules when the Company is notified early in the process.

7. PG&E must approve all requests for gas service in a casing before installation. Provide and install an approved casing (i.e., sleeve) under the paving material when the paving will extend over the gas service lateral. Applicants must ensure that:
 - a. The casing is made of a PG&E-approved material. Refer to [Gas Design Standard A-75](#), located in [Appendix C](#).
 - b. PG&E employees and equipment have sufficient, safe, and unobstructed access to the casing location with sufficient space to perform any required work when installing in a joint trench.
 - c. Before paving, a minimum 3-inch casing (i.e., sleeve) is placed around the gas service riser.
8. PG&E Procedure TD-4632P-01, “Cross Bore Prevention and Mitigation,” provides the steps that must be taken to prevent, inspect, identify, report, and address cross bores that are created when PG&E, its contractors, and contracting agencies perform trenchless construction. All gas construction work performed by or for PG&E is subject to this procedure, including PG&E gas-for-electric work (PG&E gas construction installs electric conduit), deep well anode installation, and applicant-installed work.

NOTE: Find additional information about cross bores at the Sewer Cleaning Safety website (<http://www.pge.com/en/safety/gaselectricsafety/sewercleaningsafety/index.page>).

- D. Install EFVs according to [Gas Design Standard A-93.3](#), located in [Appendix C](#).
- E. For more information and illustrations, see PG&E Standard S5453, “Joint Trench,” [Exhibit B, Joint Trench Configurations & Occupancy Guide](#), located in [Appendix B](#).
- F. Underground warning tape is required for all gas service and main pipeline installations as described in [Gas Design Standard L-16](#), “Gas Pipeline Underground Warning Tape,” located in [Appendix C](#).
- G. Figure 2-2, “Gas-Only Service Trench;” Figure 2-3, “Typical Gas Bell Hole–Plan View;” and Figure 2-4, “Typical Bell Hole Depth–Profile View,” show the typical, PG&E-required excavation for a gas-only service trench and gas bell hole. All three figures are located on Page 2-9.

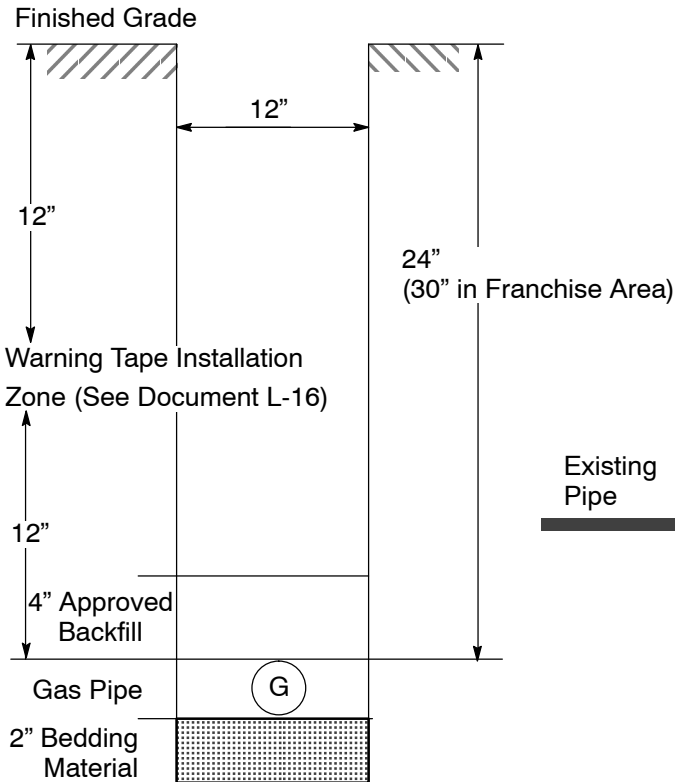

**Figure 2-2
Gas-Only Service Trench**

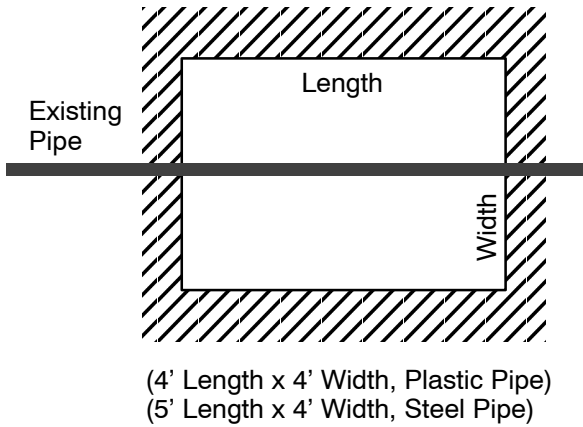

**Figure 2-3
Typical Gas Bell Hole-Plan View**

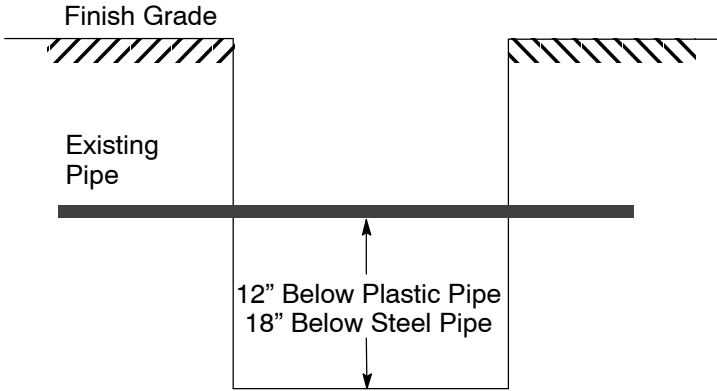

**Figure 2-4
Typical Bell Hole Depth-Profile View**

Notes in reference to Figure 2-2, Figure 2-3, and Figure 2-4.

- 1. All dimensions are the minimum required amounts.
- 2. For Figure 2-2, “Gas-Only Service Trench,” soil compaction must meet PG&E’s and any applicable federal, state, county, and local requirements.
- 3. Some jobs may require bell holes with larger dimensions and trench shoring.

2.3.2. Branch Service Pipe

Branching may be used to provide service to no more than two buildings. The meter installations must be located on adjacent sides of the two buildings being served. Where a branch-service installation is justified, a separate location for the gas meter and electric meter is permissible, if necessary.

Design and install all branch services as described in [Gas Design Standard A-42](#), “Standard Branch Service Installation,” and [Gas Design Standard A-90](#), both located in [Appendix C](#).

2.3.3. Curb Valves

A. A curb shutoff valve is required to be installed when one or all of the following conditions exist:

1. The total meter capacity exceeds 1,000 standard cubic feet per hour, and an EFV is not required and not installed. Refer to [Gas Design Standard A-93.3](#), located in [Appendix C](#), for EFV requirements.
2. The shutoff valve is not readily accessible or is inside a building and the service shutoff valve is enclosed (e.g., basement, garage, or similar obstructed location).
3. An EFV is not required and not installed, and the service line cannot be quickly squeezed off because of wall-to-wall paving, concrete, depth of cover, or other surface conditions. This includes known, planned depth of cover or other surface conditions. Typically, a service line that is installed in a lawn area with normal soil conditions (i.e., no wall-to-wall paving, concrete, or other obstruction over the service line) may be quickly squeezed off.

Typically, a service line installed in a lawn area with normal soil conditions (i.e., no wall-to-wall paving, concrete, or other obstruction over the service line) also may be squeezed off quickly.

NOTE: The best location for installing a service line is **more than 5 feet** from any building, as **close to the property line** as practical. Protect the service line in a covered, durable curb box or valve box that allows the curb valve to be operated easily.

B. PG&E **requires** curb valves on services that supply buildings used for public assembly. Such buildings include, but are not limited to:

- Theaters
- Churches
- Auditoriums
- Arenas
- Schools
- Hospitals

C. PG&E **may require** curb valves on small, gas-distribution systems. These systems include, but are not limited to:

- Mobile home parks (**not** individual mobile homes)
- Condominiums and apartments
- Multiple buildings
- Shopping centers
- Commercial/industrial parks

2.3.4. Joint Utility Service Trenches

When installing underground electric service, PG&E's gas service lateral usually is installed in a common joint trench with the electric service lateral. The joint trench typically includes telephone and cable television facilities. No other utilities or wiring (i.e., water, sewer, private wires) are allowed in a joint trench. See the definition for "Non-Utility" in [Appendix A](#), "Acronyms and Glossary."

When planning to install a joint-trench installation, allow for additional lead time to design and engineer the joint trench. Applicants must be aware of the following requirements.

1. A joint trench composite drawing and an "Authorization for Joint Trench Construction, Form B" both are required when PG&E facilities are located in a trench with other utilities.
2. Applicants either must submit joint trench drawings to PG&E for review, or PG&E can prepare joint trench drawings for applicants at their expense.
3. PG&E must approve the trench's design details **before** trenching begins and facilities are installed.
4. Figure 2-5 below shows the layout of a "Typical Joint-Service Trench."

Separation and clearance details for joint utility service trenches are located in Table 2-1, "Minimum Separation and Clearance Requirements for Trenches," on Page 2-13.

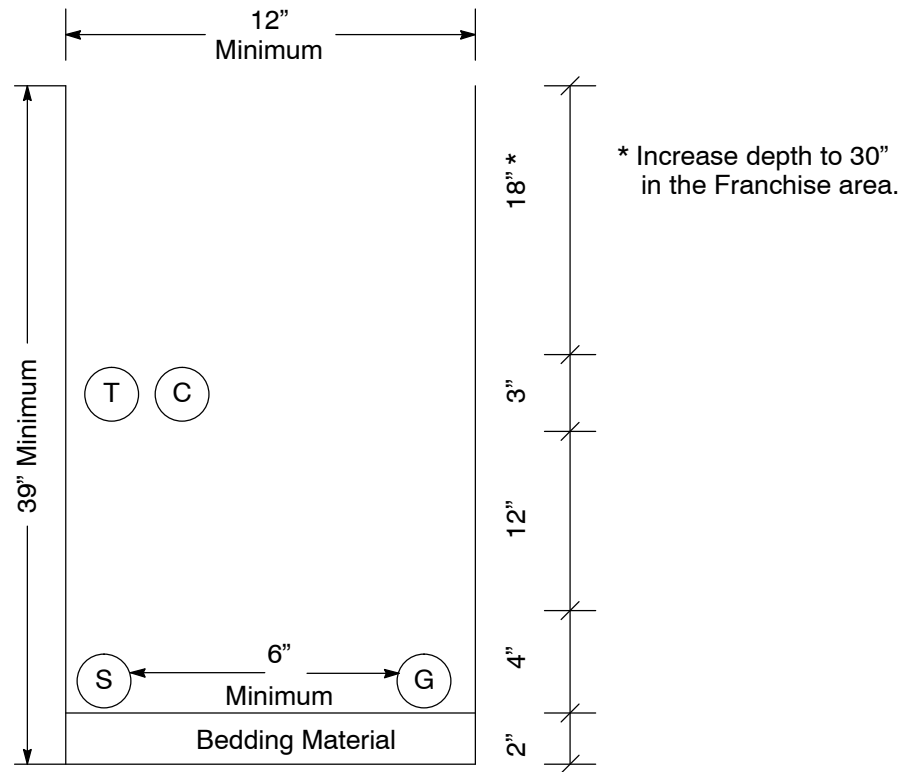

**Figure 2-5
Typical Joint-Service Trench**

Notes in reference to Figure 2-5 on Page 2-12.

1. Trench depth varies depending on the occupant's facility allotment.
2. Soil compaction must meet PG&E's, and any applicable federal, state, county, and local requirements.
3. A joint service trench must meet all separation and clearance dimensions shown in Table 2-1, below.
4. For more information on Figure 2-5, see PG&E's [Joint Trench Configurations & Occupancy Guide](#), located in [Appendix B](#).

Table 2-1 Minimum Separation and Clearance Requirements for Trenches¹

		G	Duct T	DB T	C	S	P	SL
(In Inches)								
G	Gas ²	–	12	12	12	6	12	6
T	Telephone (Duct)	12	–	1	1	12	12	12
T	Telephone (Direct Bury)	12	1	–	1	12	12	12
C	CATV	12	1	1	–	12	12	12
S	Electric Secondary	6	12	12	12	1.5	3	1.5
P	Electric Primary	12	12	12	12	3	3	3
SL	Streetlight ³	6	12	12	12	1.5	3	1.5
NE	Foreign Electric Sources, Non-PG&E ⁴	12	12	12	12	12	12	12

¹ All separation clearance distances are in inches.

² For more information about this table, see [PG&E Bulletin TD-5453B-002](#), “Updated Separation Requirements For Conduit in Joint Trench,” located in [Appendix B](#).

³ Streetlight circuits **not owned** by PG&E must be installed to meet the requirements in PG&E’s [Joint Trench Configurations & Occupancy Guide](#). Specifically, applicants must review the requirements for working with a second utility company.

⁴ Considered a “utility” as defined in [PG&E Standard S5453](#), “Joint Trench.”

PG&E does **not** differentiate between the clearances for casing/conduit and pipe. The clearances and installation requirements are the same for both.

For more information on the minimum separation and clearance requirements for service trenches, see Engineering Material Specification [EMS-4123](#), “Backfill Sand,” located in [Appendix B](#).

When different service facilities (e.g., gas, electric, telecommunications) are installed in close proximity (e.g., in a joint trench), applicants must ensure that the facilities maintain a minimum horizontal separation of 36 inches from the gas riser where they transition from below ground to above ground.

Clearances between other facilities can be reduced **only** when the parties supplying those services or facilities reach a mutual agreement.

NOTE: Applicants must ensure that sufficient space is provided between facilities at all times to allow for safe maintenance and operation.

A. Applicants must **not** install any electrical devices or equipment including wires, cables, metering and telecommunication enclosures, bond wires, clamps, or ground rods within 36 inches of the gas service riser.

This distance can be reduced to 18 inches for electrical devices or equipment certified for National Electric Code (NEC) Class I, Division 2 locations. See Figure 2-19, “Electric and Gas Meter Set Separation Dimensions and Clearances,” on Page 2-32, and Figure 2-21, “Gas Regulator Set Clearance Requirement from Sources of Ignition,” on Page 2-34.

- B. Applicants must keep the area immediately behind gas meters, service facilities, and risers free and clear of all other facilities or equipment (i.e., pipes, building vents, or conduits). This requirement also applies to the area between those facilities and the premises or structure being served.

Before installing utility conduits or gas service piping, applicants must discuss the service arrangements and coordinate the meter locations and joint trench requirements with a PG&E project coordinator.

The joint trench composite drawing must include details of the sizes and quantities of all the equipment sharing the trench. **PG&E inspectors must approve the trench after installation is complete.**

Applicants must ensure that the gas and electric meters are installed according to Figure 2-19 on Page 2-32, providing the minimum separation clearances. Refer to the following sections of this manual for acceptable electric meter utility locations.

- [Section 5](#), “Electric Metering: General”
- [Section 6](#), “Electric Metering: Residential”
- [Section 7](#), “Electric Metering: Commercial, Industrial, and Agricultural”
- Subsection 2.4., “Set Requirements for Gas Meters” (on Page 2-19)

Wet-utility piping or facilities are **not** permitted in a joint trench. Examples of wet utilities that are not allowed in a joint trench include the following:

- Propane lines
- Pressurized water lines
- Sewer, sanitary, or storm drains

Both PG&E Standard S5453, [Exhibit B](#), and the [Joint Trench Configurations & Occupancy Guide](#), located in [Appendix B](#), describe the requirements for separating a wet utility from a joint trench.

When applicants want to install facilities in a joint trench other than those listed in this section, PG&E requires a **written** request that includes a justification for the exception. Applicants must submit their requests to PG&E for review and approval **before** beginning work on a joint trench.

2.3.5. Multiple Buildings Located on One Lot

A. Two Buildings Located on One Lot

1. PG&E may furnish a separate gas service to each building if it does **not** require an additional gas distribution main extension.

Figure 2-6, “Separate Gas Services for Two Buildings on a Single Lot,” on Page 2-13, and Figure 2-7, “Separate Gas Services for Two Buildings on a Corner Lot,” on Page 2-16, show examples of two premises on one lot with separate gas services.

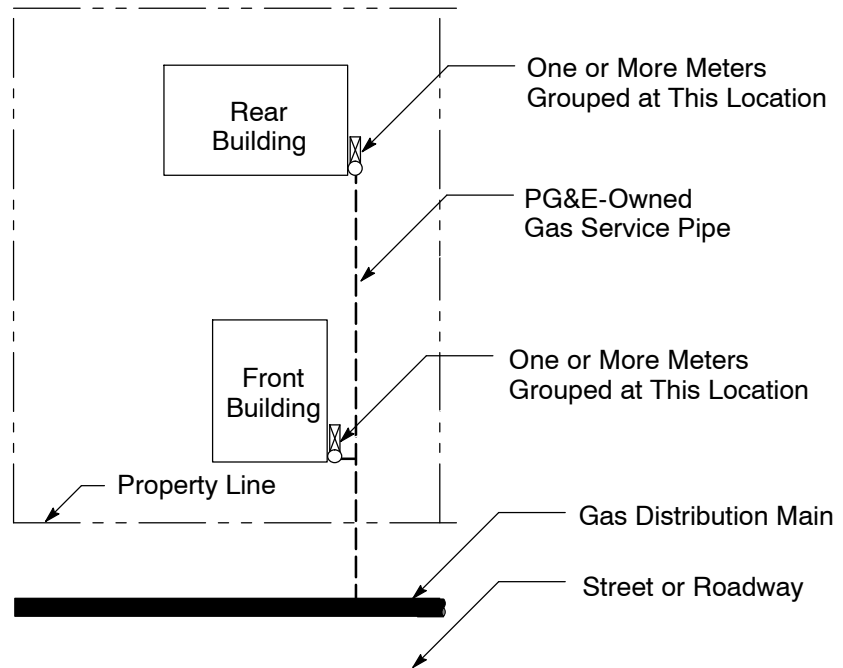

Figure 2-6
Separate Gas Services for Two Buildings on a Single Lot

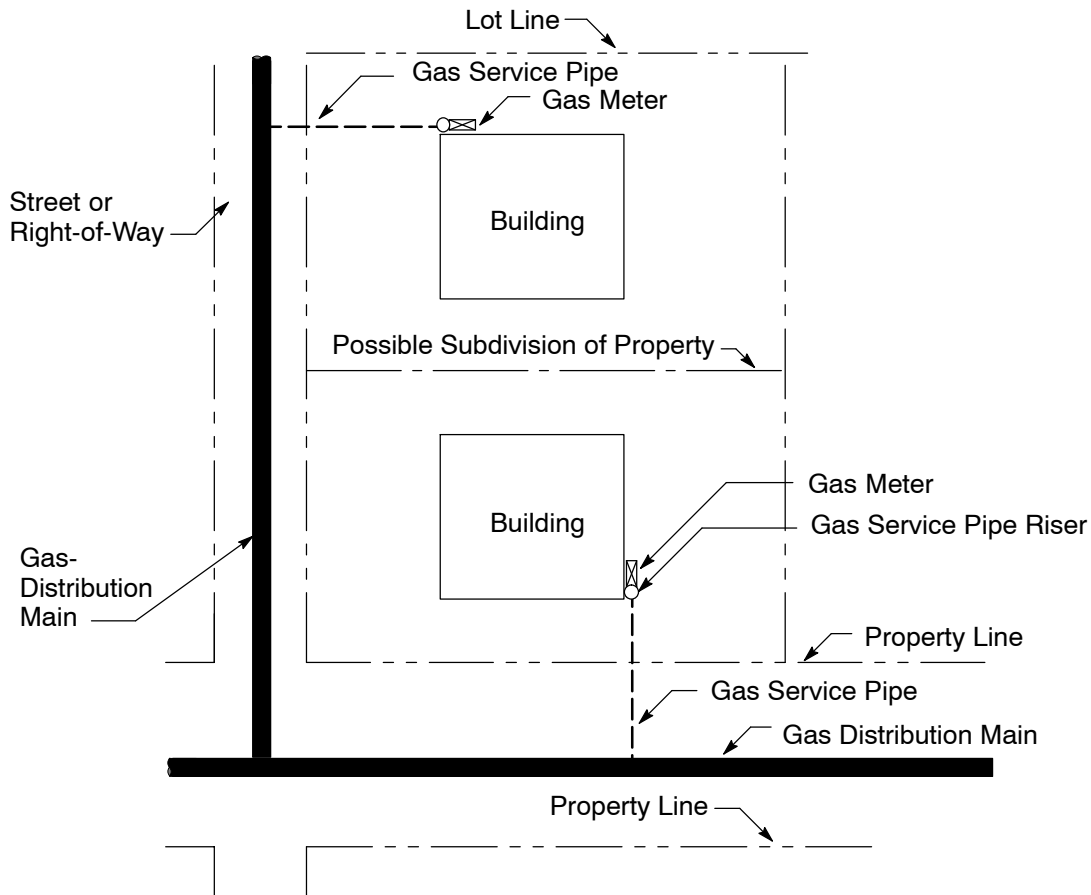

Figure 2-7
Separate Gas Services for Two Buildings on a Corner Lot

2. When more than one gas meter is required to serve a single building, the meters for that building must be grouped at a common location that has been approved by PG&E. See Subsection 2.4.2.E., “Multiple Gas Meter Connection Requirements for Single and Double (Banked) Manifold Connections,” on Page 2-34, for grouping requirements when locations have multiple meters.

B. Three or More Buildings Located on One Lot

When two buildings, either single family or multifamily, are on the same lot and located in close proximity to each other, PG&E may install a gas distribution main on the applicants’ properties. For specific requirements, see PG&E’s main-extension rule, [Gas Rule 15](#), and service-pipe extension rule, [Gas Rule 16](#). Before a gas distribution main can be installed, applicants must ensure that the following conditions are met.

1. There must be a protected and accessible location on the property.
2. A satisfactory right-of-way, easement, or permit must be available at no cost to PG&E.

Typically, PG&E installs a single, gas-service pipe to each building, as described in [Gas Rule 16](#).

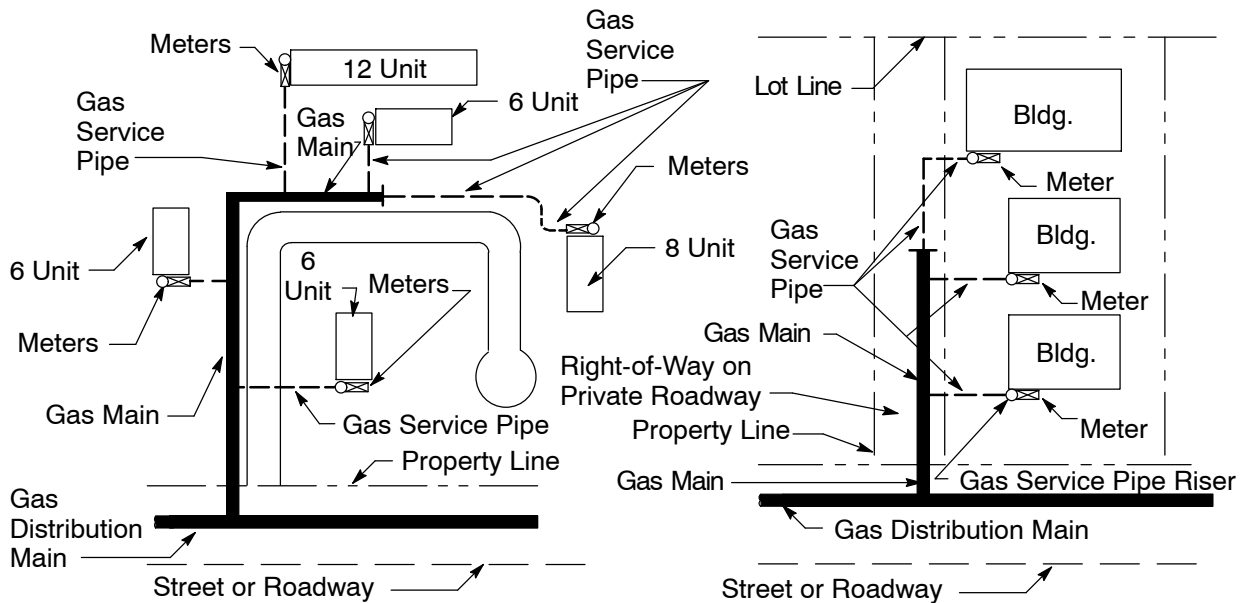

Figure 2-8
Apartments With Grouped Meter Locations

Figure 2-9
Individually Metered Buildings

**Typical Gas Distribution Main and Service Pipe Installation
for Property With Three or More Buildings**

Multifamily residential complexes are subject to a California Public Utilities Commission (CPUC) mandate specifying that each unit is metered individually. Specifically, see [Public Utilities Code Division 1, “Regulation of Public Utilities,” Part 1, “Public Utilities Act,” Chapter 4, “Regulation of Public Utilities,” Article 3, “Equipment, Practices, and Facilities,” Section 780.5](http://leginfo.legislature.ca.gov/faces/codes_displaySection.xhtml?sectionNum=780.5.&lawCode=PUC) (on the Internet at http://leginfo.legislature.ca.gov/faces/codes_displaySection.xhtml?sectionNum=780.5.&lawCode=PUC).

EXCEPTION: A single gas meter may serve an entire complex when the gas is used only for central heating systems (i.e., space, water) that supply all tenants in common, and when each individual unit does **not** use gas appliances that require combustion venting. Refer to [Gas Rule 18](#), “Supply to Separate Premises and Submetering of Gas.”

When each dwelling unit includes ground-floor space, each unit may have an individual service pipe and separate meter location **if**:

1. Sufficient meter space is provided.
2. Local ordinances do **not** prohibit such arrangements.

When it is practical, install the gas service pipe in a joint trench with the electric service.

A multifamily apartment building with individually metered spaces may have more than one service connection under the standard provisions of [Gas Rule 16](#) if **all** of the following conditions exist.

1. An unreasonable burden, in PG&E's opinion, will be placed on the customer restricted to one service connection.
2. Service connections are a minimum of 150 feet apart.
3. Each service connection provides service to a minimum group of four meters.
4. Local code or ordinance allows the multi-service arrangement.

NOTE: For more information, see PG&E's [Gas Rule 16](#), Section C.2, "Number of Extensions."

5. Local code or ordinance allows for the multi-service arrangement.

See Subsection 2.4.2.E. on Page 2-34 for specific requirements when locations have multiple meters.

2.3.6. Mobile Home Parks

Gas mains and services in mobile home parks must meet essentially the same standards for gas installations that are required for residential and nonresidential applications.

In addition, applicants must **not** install gas mains, services, and meters in the following areas.

- On steep slopes.
- In areas where landscaping restricts access.
- Under existing or proposed structures including mobile homes, porches, and stairs leading to porches.

Applicants should install the gas distribution mains in the roadway, when it is practical to do so, and in joint trenches, when it is feasible. Locate distribution mains 10 feet from the face or foundation of any building as described in [Gas Design Standard A-90](#) located in [Appendix C](#). On private property, ensure that rights-of-way are at least 10 feet wide for mains and at least 5 feet wide for service piping. Only use easements for utility installations. Table 2-1 on Page 2-13 shows the minimum separation and clearance requirements for service trenches.

NOTE: Curb valves are **not** recommended for individual mobile homes; however, a curb valve may be installed on a park's community building.

NOTE: Refer to [Gas Design Standard J-12.4](#), "Mobile Home/Manufactured Home Meter Set Installation." Contact your local project coordinator for this document.

Also see the gas meter set requirements in Subsection 2.4.2.A.3., "Mobile Home Parks," on Page 2-23.

2.4. Set Requirements for Gas Meters

The following information describes the meter set requirements for gas services.

2.4.1. Gas Pressure

The following information describes the types of delivery pressures available with gas service.

A. Standard Delivery Pressure

PG&E typically will provide gas service pressure to the service delivery point at 7 inches of water column (WC). This is approximately 1/4 psig, as measured at the gas meter outlet.

B. Elevated Delivery Pressure

PG&E may be able to provide gas service at higher gas-delivery pressures, depending on the location of the applicant's facility and on the requirements of the gas system serving that location. PG&E maintains sole authority to determine if the elevated delivery-pressure service is available at a specified location.

In all elevated delivery-pressure service situations, PG&E reserves the right to reduce the gas service pressure to standard delivery pressure, as outlined in [Gas Rule 2](#), "Description of Service," when:

- PG&E determines that the elevated gas pressure is no longer available.
- The current delivery pressure is detrimental to PG&E's gas distribution system.

NOTE: When providing elevated gas-pressure service, PG&E can incur additional costs. In these cases, special facilities charges will apply as described in [Gas Rule 2](#). Applicants must pay these charges **before** PG&E can provide the services.

The following two numbered items describe cases where special facilities charges can apply.

1. **For 2-psig Services:** In many PG&E service territories with sufficient distribution operating pressure, 2-psig delivery pressure may be available. When completing PG&E's "[Application for Service](#)" form, applicants must request 2-psig gas-service delivery pressure in the "Load Information" section. In most cases, special facilities charges will **not** apply for a 2-psig delivery request. As mentioned previously, PG&E will determine if special facilities charges apply.
2. **For Services Higher Than 2 psig:** Elevated gas-metering pressures higher than 2 psig may be available from the local gas distribution system. PG&E must ensure that tapping into this existing service will **not** be detrimental to the operation of that gas system.

When requesting elevated gas-service delivery pressure higher than 2 psig, applicants must follow these steps.

- a. Contact the local PG&E project coordinator as soon as possible (preferably in the **planning** stage for a new or remodeled building).
- b. Fill out the appropriate PG&E “[Application for Service](#)” form and note the gas-service delivery pressure being requested in the “Load Information” portion of the form.
- c. Submit a formal, written request and justification for elevated gas-service delivery pressure (e.g., the hypothetical houseline diameter size at standard delivery pressure, the appliances’ specification requirements).
- d. Submit a houseline piping schematic.
- e. Submit the manufacturer’s appliance specifications to ensure that the appliances will operate as designed.
- f. Provide detailed load information for all appliances and their intended use.

C. Back-Pressure Protection

PG&E may require the applicant to install a check valve after the PG&E gas meter’s set point of connection. This check valve prevents backflow. PG&E determines the need for check valves on a case-by-case basis. The applicant is required to have a maintenance plan and to maintain the check valve.

For all higher-than-standard delivery pressure, PG&E recommends that applicants hire a qualified person, such as plumber or contractor, to review all of the applicant-owned gas piping, venting, and appliance installations for the gas pressure service being requested. The qualified person can ensure that the installations comply with all local, state, and federal codes, standards, and regulations. Specifically, the qualified person helps to ensure that the [Uniform Plumbing Code](#) is enforced based on the installation requirements of the local governing agency in the applicant’s location.

2.4.2. Gas Meter-Set Locations

Typically, PG&E provides only one meter set (in an outside location) for each dwelling unit and one service lateral to each building. PG&E may require that the meter be set at the property line if **either** of the following two conditions are met:

1. The building is back more than 200 feet from the property line.
2. A potential hazard or unusual site condition threatens the service lateral between the property line and the building. Some examples of unusual site condition are plowed land, ditches, bridges, ponds, waterways, leach fields, bioswales, inaccessible security areas, or other deterrent, obstacle, or hazard.

PG&E prefers that rotary meter sets be located outside of and away from the building.

PG&E must have unrestricted, drive-up access for service trucks and adequate space to install and maintain the meter.

Any deviations require advanced approval from PG&E.

For specific information, see [Gas Rule 16](#), Section C, Number 5, “Unusual Site Conditions.” Figure 2-10, “Property Line Installation,” below, shows a property-line meter set installation.

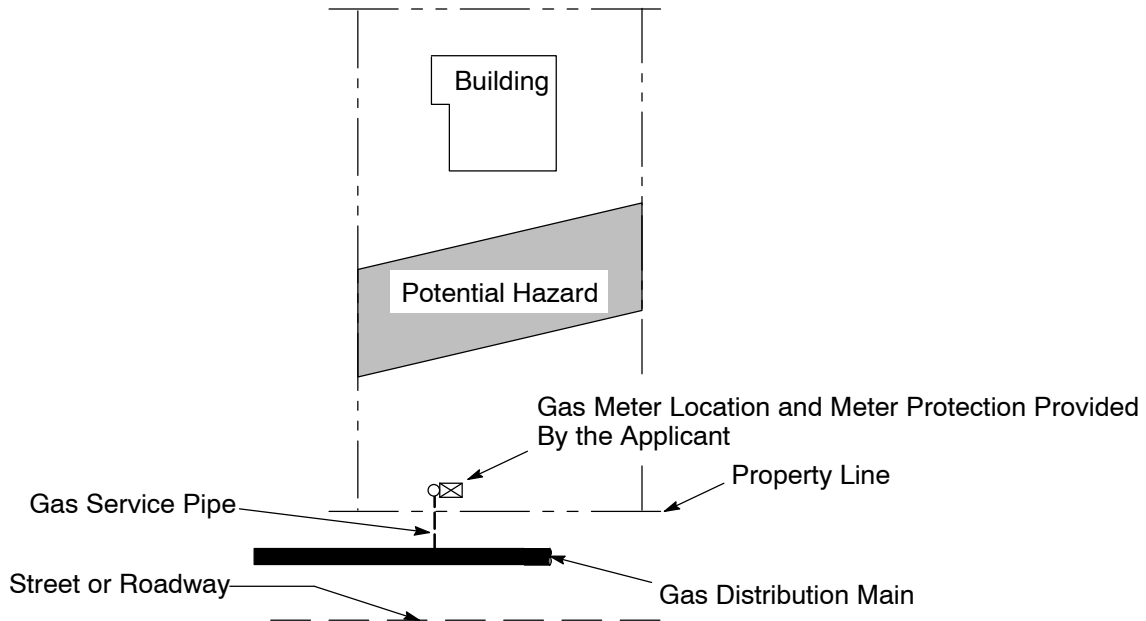

Figure 2-10
Property Line Installation

A. Descriptions of Acceptable Meter Locations

For descriptions of, and specific requirements for, acceptable gas meter locations, see [Gas Design Standard J-15](#), “Gas Meter Locations,” located in [Appendix C](#).

Figure 2-11, “Acceptable Locations for Gas Meter Installations,” on Page 2-23, and Figure 2-12, “Acceptable Meter Locations for Mobile Home Parks,” on Page 2-24, illustrate locations that are acceptable for installing typical meter sets.

1. Approved Meter Set Locations (In Order of Preference)

NOTE: For specific requirements and definitions, see [Gas Design Standard J-15](#), located in [Appendix C](#).

- a. Meter set located outside a building.
- b. Meter set located outside in an alcove or enclosure. *

*An alcove is an exterior space that is recessed into a building or wall. The alcove's width can vary depending on the meter set. PG&E provides final dimensions after confirming the meter size. Please consult your local Service Planning office for guidance.

For single-diaphragm meters, applicants must use the area dimensions shaded in Figure 2-14 on Page 2-27 and Figure 2-15 on Page 2-28 (depth not to exceed 36 inches).

For single-rotary meters, use the area dimensions shaded in Figure 2-16 on Page 2-29, Figure 2-17 on Page 2-30, and Figure 2-18 on Page 2-31 (depth not to exceed 36 inches and height at 8 feet).

A manifold located in an alcove may require a custom design depending on the configuration.

Gates are not a preferred option and will be approved only on a case-by-case basis. If a gate is proposed in front of the alcove, it must have a minimum 50% open area. Lighting, wiring, foreign pipes, or other facilities **are not allowed** in the alcove.

Contact your local PG&E project coordinator for more information.

- c. Meter set located in a breezeway.
- d. Meter set located in a cabinet.

NOTE: PG&E will consider approving Numbers e. and f., below, only after Numbers a. through d. on Page 2-22 are ruled out as options.

- e. Meter set located in a buried vault, pit, or box.
- f. Meter set (excluding service shutoff valve) located inside a building in a gas meter room.

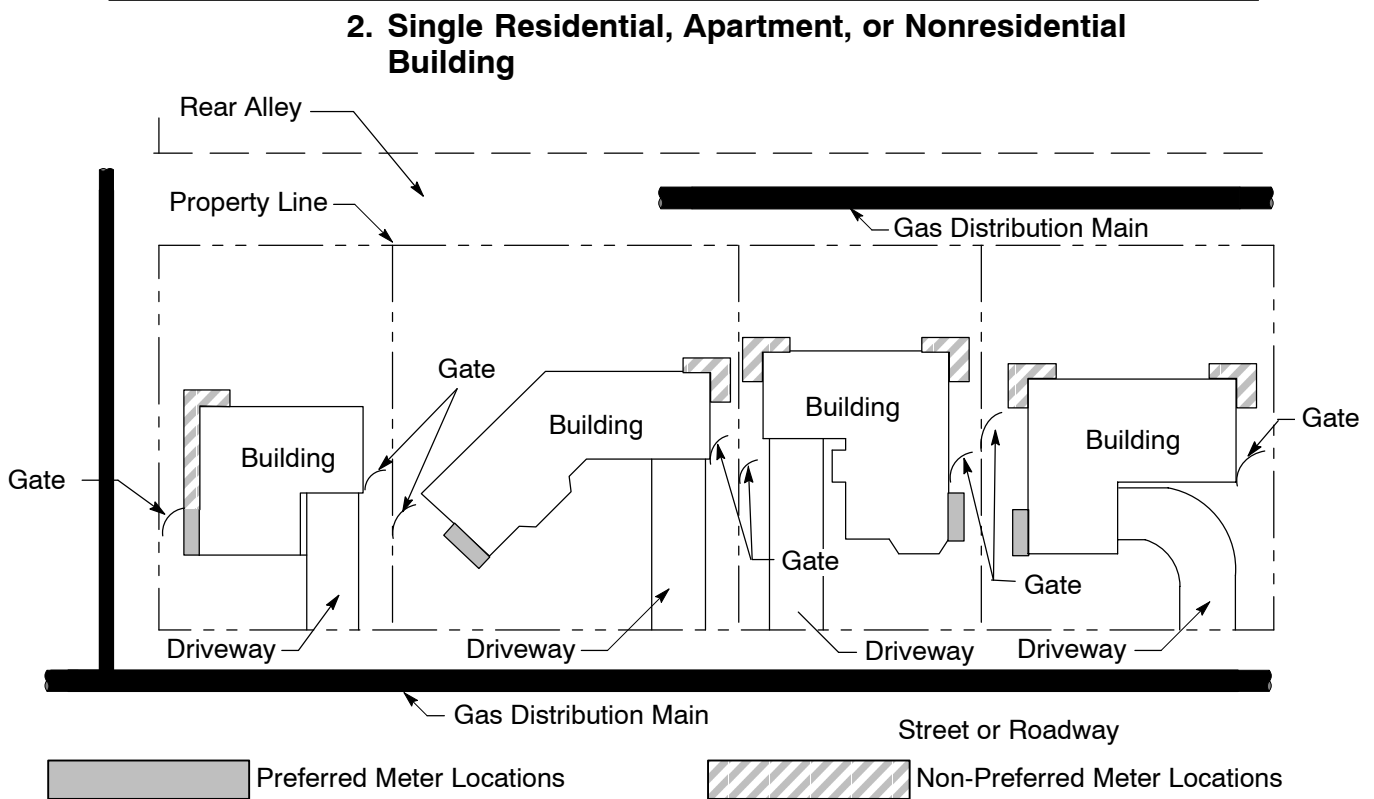

Figure 2-11
Acceptable Locations for Gas Meter Installations

NOTE: When the meter set from the gas distribution line is located in a rear alley, applicants should locate the meter set outside of any gated or fenced area. This allows easy access for PG&E employees when maintenance is required.

3. Mobile Home Parks

For new mobile home parks, the mobile home park owner or operator must provide a separate and independent meter for each lot. New mobile home parks are not allowed to have submetering facilities.

Typically, meters are located on flat surfaces that are not obstructed by landscaping. Meter locations cannot be obstructed by porches and stairs leading to porches. Figure 2-12, on Page 2-24, represents several acceptable meter locations within a typical mobile home park.

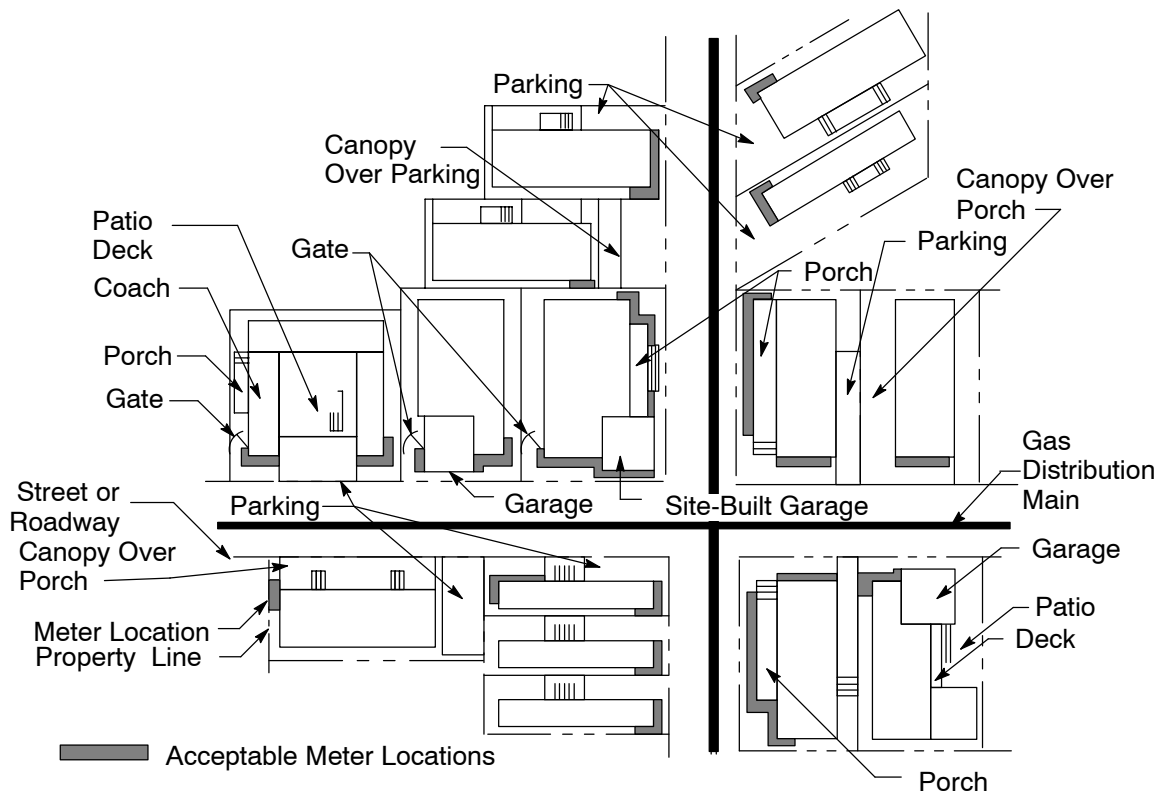

Figure 2-12
Acceptable Meter Locations for Mobile Home Parks

PG&E does **not** provide metering facilities if they will be attached directly to a “movable” mobile home unit that is installed or set up in any location, including a mobile home park. Before PG&E provides metering facilities, the mobile home must meet **both** of the following conditions.

- a. **Fixed in Place:** The mobile home typically does not have either running gear or wheels and is not capable of being moved to another location.
- b. **Installed on a Foundation System:** The mobile home must have a foundation system, as described in *State of California Title 25, “Housing and Community Development Programs,”* Division 1, “Housing and Community Development,” Chapter 2, “Mobilehome Parks and Installations,” Article 7, “MH-Unit and Commercial Modular Installations and Facilities,” [§ 1333](#), “Foundation Systems.”

“If a mobile home park contains lots or site spaces that are set up to accommodate “movable” mobile home units, PG&E will install and supply the park using utility-approved service and metering facilities at a fixed location other than the mobile home. In these cases, applicants are responsible for connecting their mobile home units to those fixed metering facilities.”

4. Subsidence Areas

In subsidence areas, the acceptable location requirements are the same as the requirements outlined in Subsection 2.4.2.A., “Descriptions of Acceptable Meter Locations,” on Page 2-21. PG&E may require a flexible connector to be installed between the gas meter outlet and the houseline. These connectors may require additional clearance space. See Figure 2-13, “Flex-Hose Meter Set–Residential and Small Commercial,” located below, for a sample installation. Contact your local project coordinator for [Gas Design Standard J-58](#), “Flex Hose Meter Set Installation,” which provides information about diaphragm and rotary meters in subsidence areas.

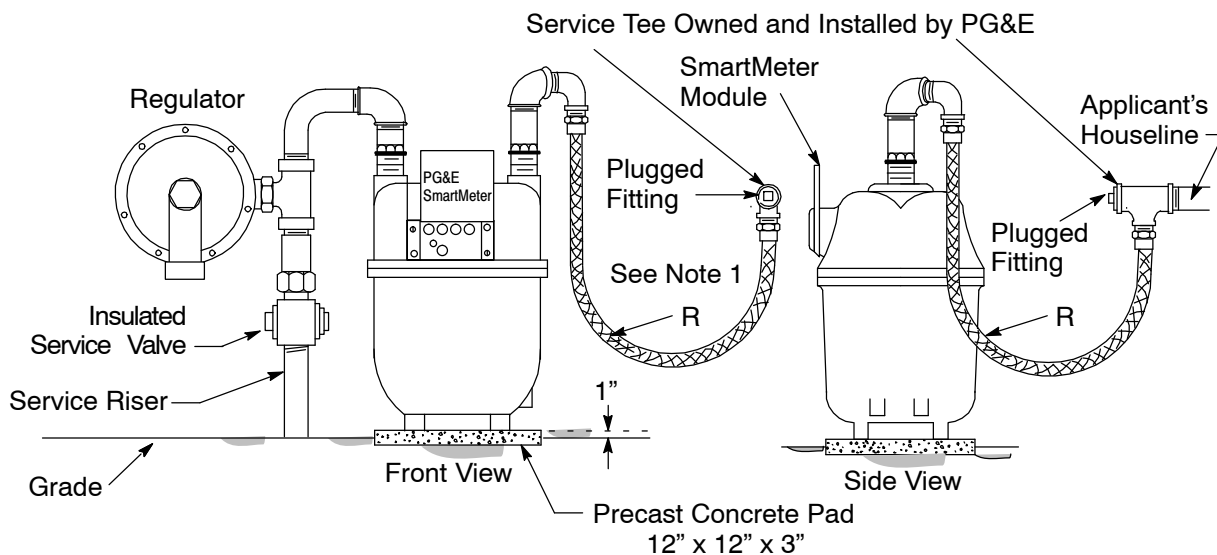

Figure 2-13
Flex-Hose Meter Set–Residential and Small Commercial

Notes in reference to Figure 2-13.

1. Hoses have a minimum bending radius (R) based on the projected settlement of the ground and on the size of the hose.

B. Descriptions of Unacceptable Meter Locations

For new or remodeled buildings, **do not locate** gas meter sets in the following areas.

1. In curb meter boxes or vaults.
2. In living quarters, closets, toilet rooms, or bathrooms.
3. In garages without properly vented meter cabinets.
4. Behind fences that applicants can lock.
5. On steep slopes.
6. In areas where landscaping restricts access.

7. Within engine, boiler, heater, or electrical-equipment rooms.
8. Under display platforms or show windows in commercial buildings. (This includes any permanent, elevated display floors or platforms associated with the window where the purpose of the window is to present a display to the public.)
9. In contact with the soil, in a depression below general ground level, or where potentially corrosive materials are likely to contact the meter set.
10. In poorly ventilated tradesman alleys (i.e., passageway in a building with a door at one end).
11. In crawl spaces under buildings or decks.
12. Near a driveway, drive-thru, or other traveled area. Gas meters located in traveled ways must be adequately protected from passing vehicles as described in [Gas Design Standard J-95](#), “Meter Guard Design and Installation Arrangement,” located in [Appendix C](#).
13. In a metallic cabinet, room, or location that blocks or interferes with the radio frequency signal transmissions that are necessary for PG&E to operate its SmartMeter™ Advanced Meter Reading system.
14. In any location that does not provide the required working space. The height dimension is 6 feet, 6 inches of clearance above ground and the depth dimension is 3 feet of clearance in front of the gas meter. See the figures in Subsection 2.4.2.C., “Single Gas Meter Connection Requirements,” below, for the different width dimensions.

NOTE: All meter locations are subject to PG&E approval.

C. Single Gas Meter Connection Requirements

The figures beginning on Page 2-27 illustrate typical meter-set dimensions and working clearance requirements based on the total diversified loads and stated delivery pressure.

NOTE: The actual meter-set configuration, including the dimensions, may be different depending on field conditions and restrictions.

Consult with your local project coordinator for the exact meter location and houseline placement and orientation. Customer-installed equipment (e.g., earthquake valves) must be installed on customer houseline and cannot reduce the minimum riser-to-houseline dimension.

A commercial meter set may require the riser to be located farther away from the face of the building to accommodate the meter’s installation. Your local project coordinator can verify that risers and houselines are installed and meet all minimum clearance requirements before scheduling the meter set installation.

- 1. Figure 2-14 represents a typical gas meter kit with 0 through 350 scfh at 7 inches WC or 0 through 600 scfh at 2 psig. Reverse sets are not allowed. The houseline must be to the right of the gas service riser.

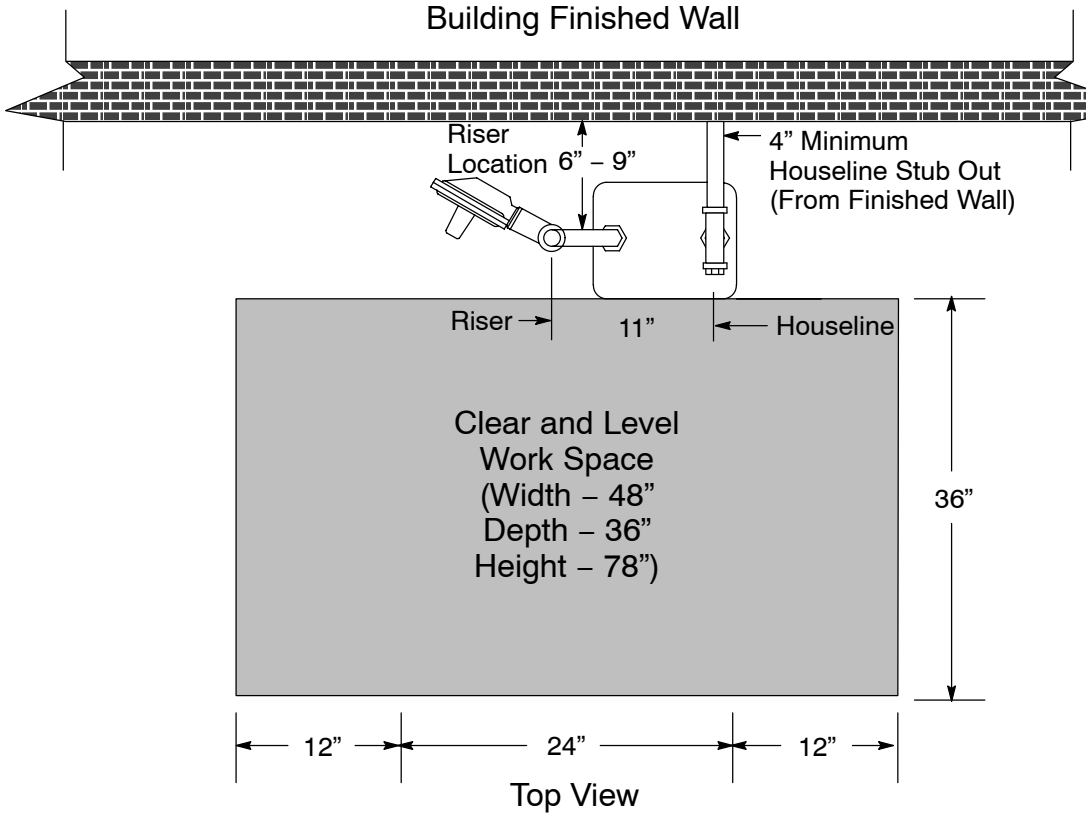

Figure 2-14
Typical Residential Gas Meter Connection

2. Figure 2-15 represents a typical gas meter kit with 351 through 1,400 scfh at 7 inches WC or 601 through 2,400 scfh at 2 psig. Do not use reverse sets for 400 through 600 class meters (i.e., 400, 425, 630). The houseline must be to the right of the gas service riser.

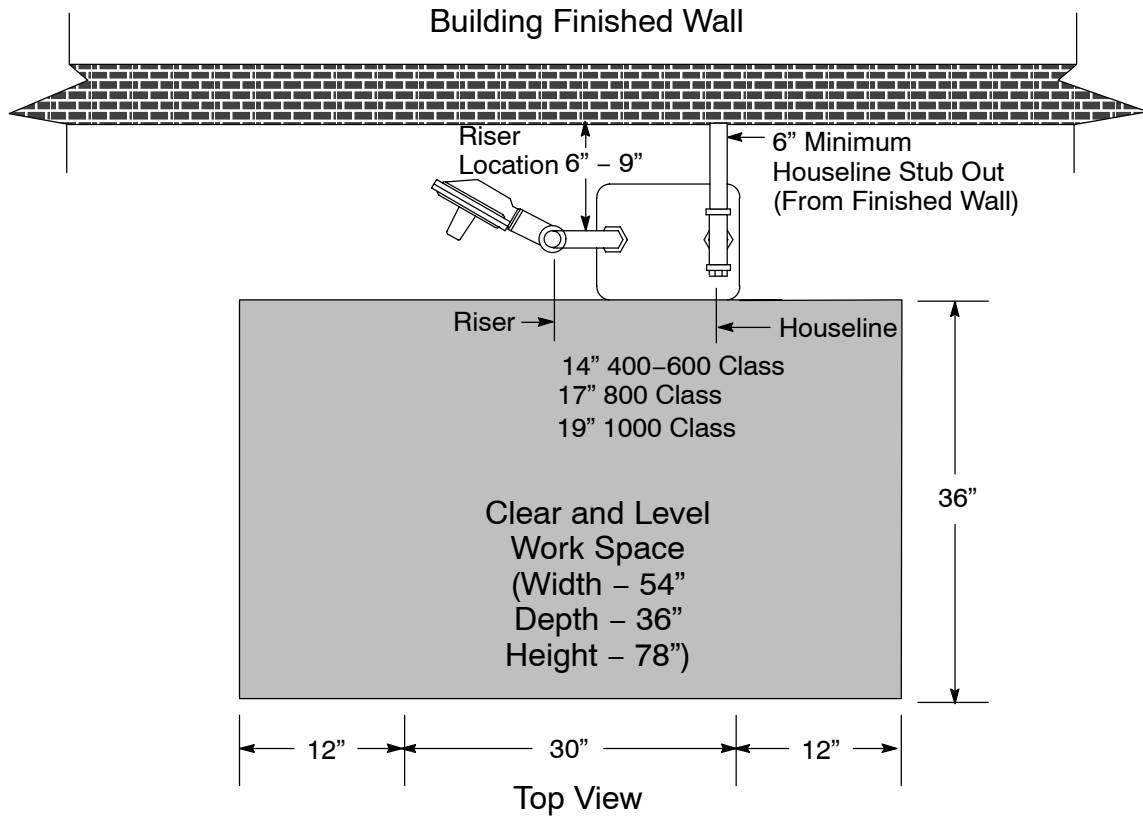

Figure 2-15
Typical Gas Meter Connection for 400 to 1,000 Class Meters

3. Figure 2-16 represents a rotary gas meter with 1,401 through 3,000 scfh at an approved delivery pressure.

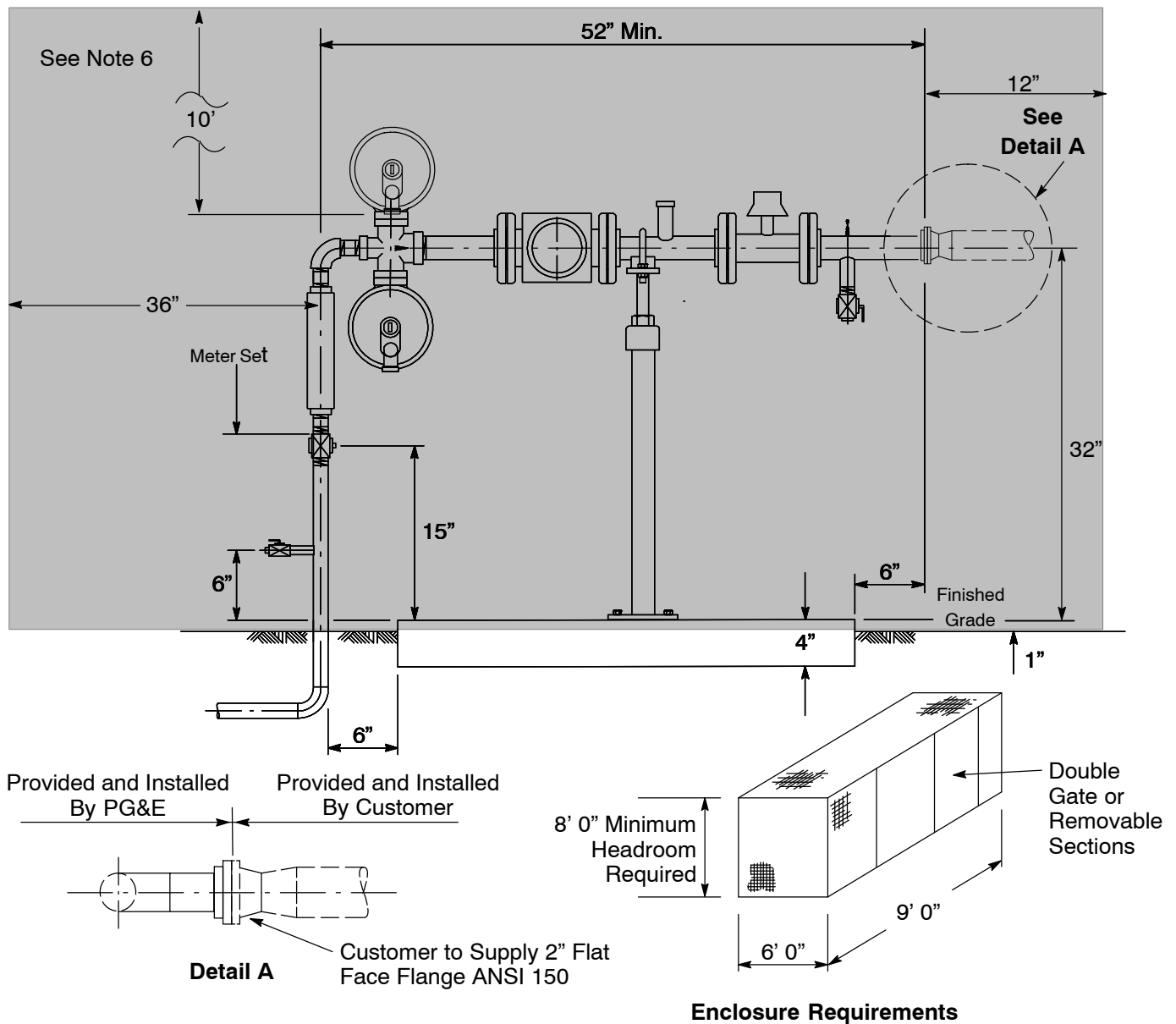

Figure 2-16
Gas Meter Connection Using a 1.5M or 3M Rotary Gas Meter

Notes in reference to Figure 2-16.

1. Customers must provide a 40 inches x 36 inches x 4 inches concrete pad with minimum #4 rebar.
2. Customers must provide a 2 inch ANSI 150 Flat Face flange to connect to PG&E facilities.
3. If the meter set is built next to a building wall, place the vertical leg of the riser and the houseline 20 inches from the wall. This ensures that the meter set components are built in a straight line.
4. The finished grade must be below the bury-line marking on the service riser.
5. PG&E's weld elbow is optional.
6. The regulator vent must not terminate near any sources of ignition or openings into the building. The riser must be a minimum of 36 inches from sources of ignition and from any openings into the building. This clearance area extends 10 feet above the highest regulator vent, 36 inches below the lowest regulator vent, and 12 inches beyond the farthest PG&E meter-set equipment.

4. Figure 2-17 represents a rotary gas meter with 3,001 through 7,000 scfh at an approved delivery pressure.

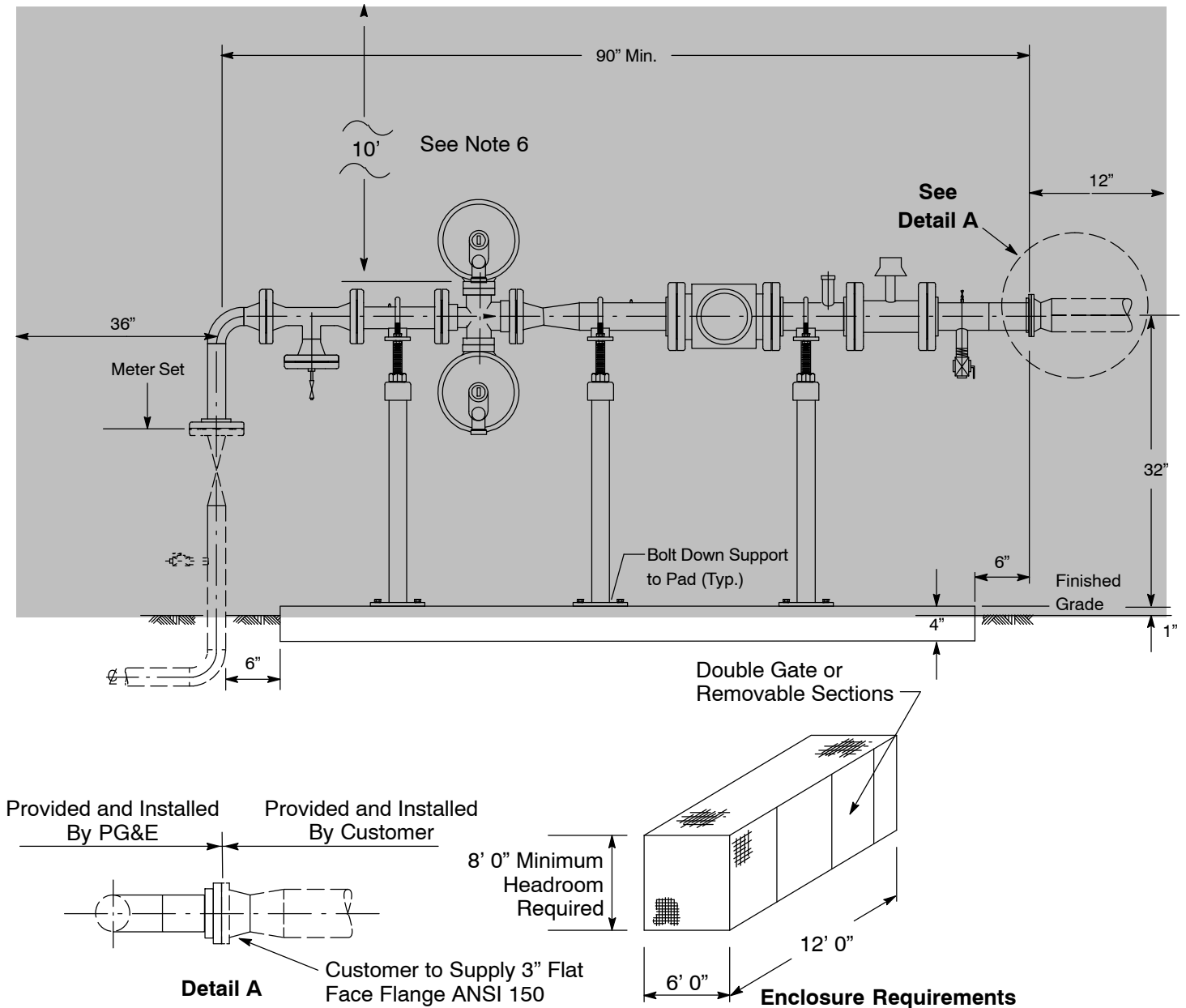

Figure 2-17
Gas Meter Connection Using a 5M or 7M Rotary Gas Meter

Notes in reference to Figure 2-17.

1. Customers must provide a 78 inches x 36 inches x 4 inches concrete pad with minimum #4 rebar.
2. Customers must provide a 3 inch ANSI 150 Flat Face flange to connect to PG&E facilities.
3. If the meter set is built next to a building wall, place the vertical leg of the riser and the houseline 20 inches away from the wall. This is to ensure the meter set components are built in a straight line.
4. The finished grade must be below the bury-line marking on the service riser.
5. PG&E's weld elbow is optional.
6. The regulator vent must not terminate near any sources of ignition or openings into the building. The riser must be a minimum distance of 36 inches from sources of ignition and openings into the building. This clearance area extends 10 feet above the highest regulator vent, 36 inches below the lowest regulator vent, and 12 inches beyond the farthest PG&E meter-set equipment.

5. Figure 2-18 represents a rotary gas meter with 7,001 through 16,000 scfh at an approved delivery pressure.

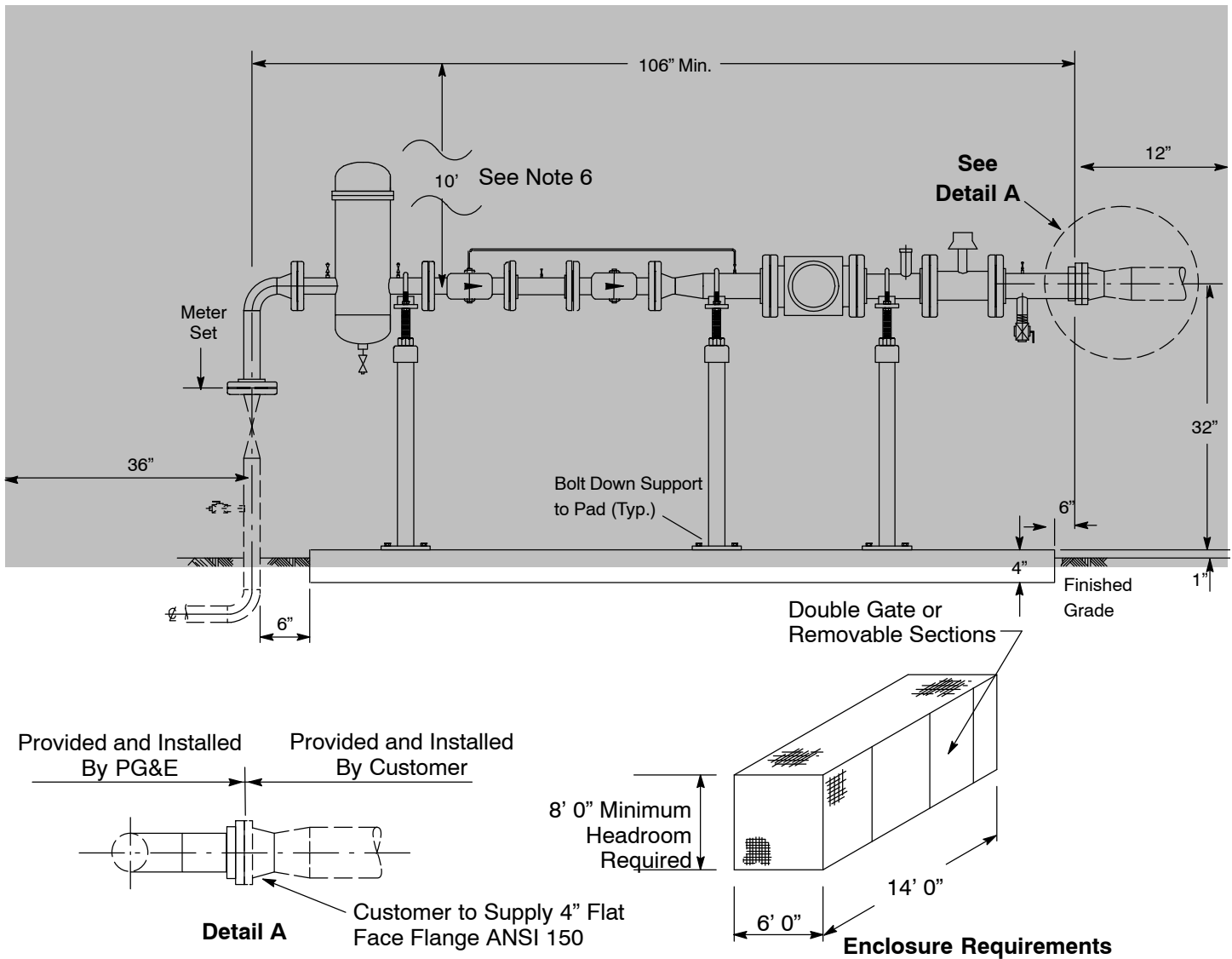

Figure 2-18
Gas Meter Connection Using an 11M or 16M Rotary Gas Meter

Notes in reference to Figure 2-18.

1. Customers must provide a 96 inch x 36 inch x 4 inch concrete pad with minimum #4 rebar.
2. Customers must provide a 4 inch ANSI 150 Flat Face flange to connect to PG&E facilities.
3. If the meter set is built next to a building wall, place the vertical leg of the riser and the houseline 20 inches away from the wall. This ensures the meter set components are built in a straight line.
4. The finished grade must be below the bury-line marking on the service riser.
5. PG&E's weld elbow is optional.
6. The regulator vent must not terminate near any sources of ignition or openings into the building. The riser must be a minimum distance of 36 inches from sources of ignition and openings into the building. This clearance area extends 10 feet above the highest regulator vent, 36 inches below the lowest regulator vent, and 12 inches beyond the farthest PG&E meter-set equipment. Contact your local project coordinator about possible locations for regulator vents. (The regulations for large, industrial meter sets can vary.)

D. Minimum Meter Set Clearance Requirements

Figure 2-19, “Electric and Gas Meter Set Separation Dimensions and Clearances,” below; Figure 2-20, “Gas Meter Set Clearance From Building Openings,” on Page 2-33; and Figure 2-21, “Gas Regulator Set Clearance Requirement From Sources of Ignition,” on Page 2-34, all represent various metering facilities’ clearance requirements. If applicants install enclosures on their premises, the enclosures must meet the specifications provided in these illustrations.

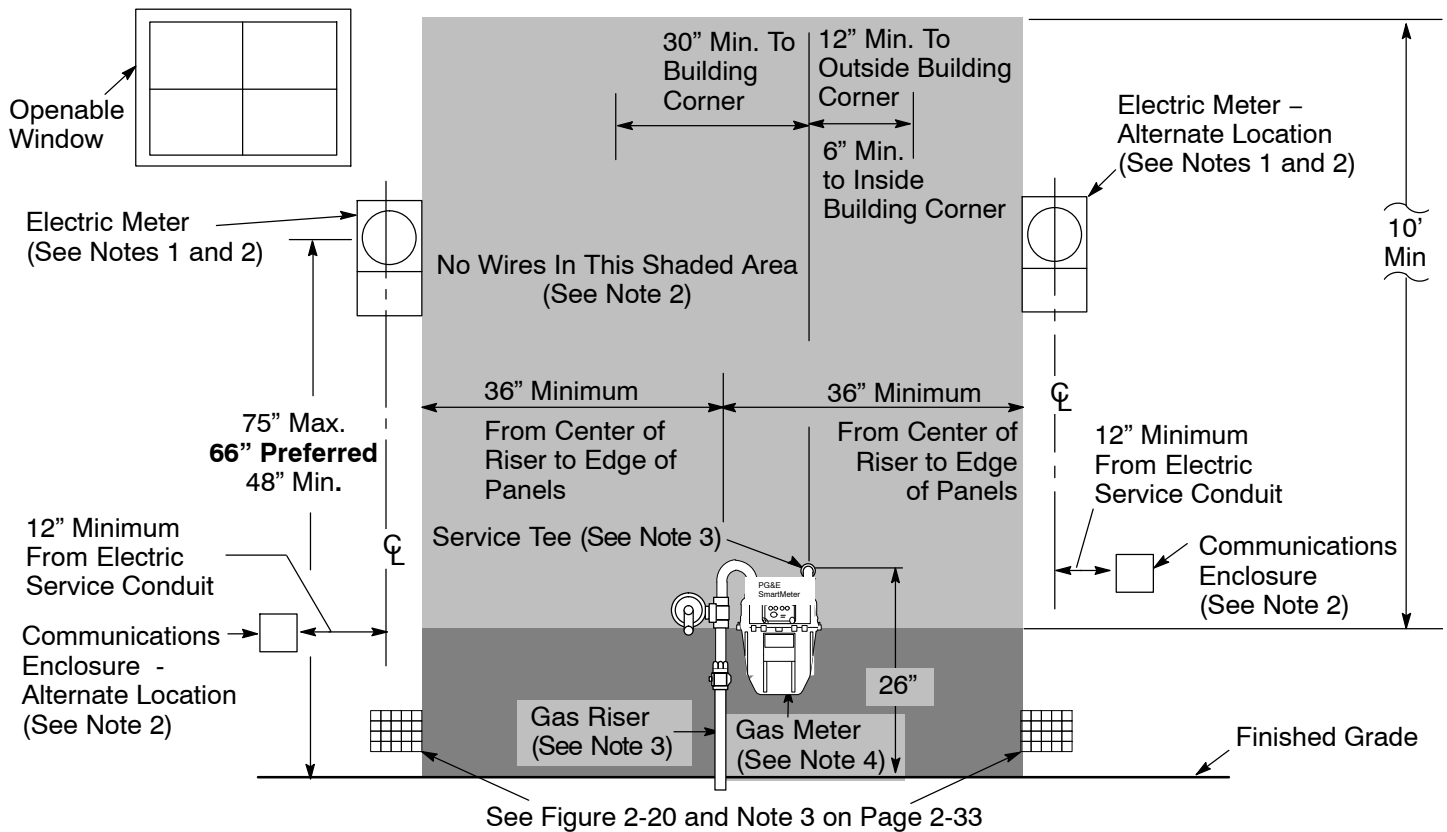

Figure 2-19
Electric and Gas Meter Set Separation Dimensions and Clearances

Notes in reference to Figure 2-19.

1. Electric meter panel locations are subject to utility approval and must comply with the applicable code requirements. PG&E does **not** have specific requirements for the distance from the electric panel to the outside building corner. See [Section 5](#), “Electric Metering: General,” for properly locating the electric meters. See Subsection 5.4.4., “Working Space,” on Page 5-12, for electric meter working space.
2. Applicants must **not** install any electrical devices or equipment, including wires, cables, metering enclosures, telecommunication enclosures, bond wires, clamps, or ground rods within the shaded area around the gas meter. The 36-inch distance can be reduced to 18 inches for electrical devices or equipment certified for NEC Class I, Division 2 locations.
3. Place the gas service riser 6 inches to 9 inches from the finished wall. The completed customer houseline at the service delivery point must extend a minimum of 4 to 6 inches from the finished wall where the meter is to be set, and must be 26 inches above the finished grade. See Figure 2-14 on Page 2-27, Figure 2-15 on Page 2-28, and Subsection 2.5. on Page 2-43.
4. The minimum dimensions and clearances in Figure 2-19 are good for gas meters up to the 1,000 class. See Figure 2-14 and Figure 2-15 on Pages 2-27 and 2-28 for illustrations of clear and level working space in front of the gas meter.

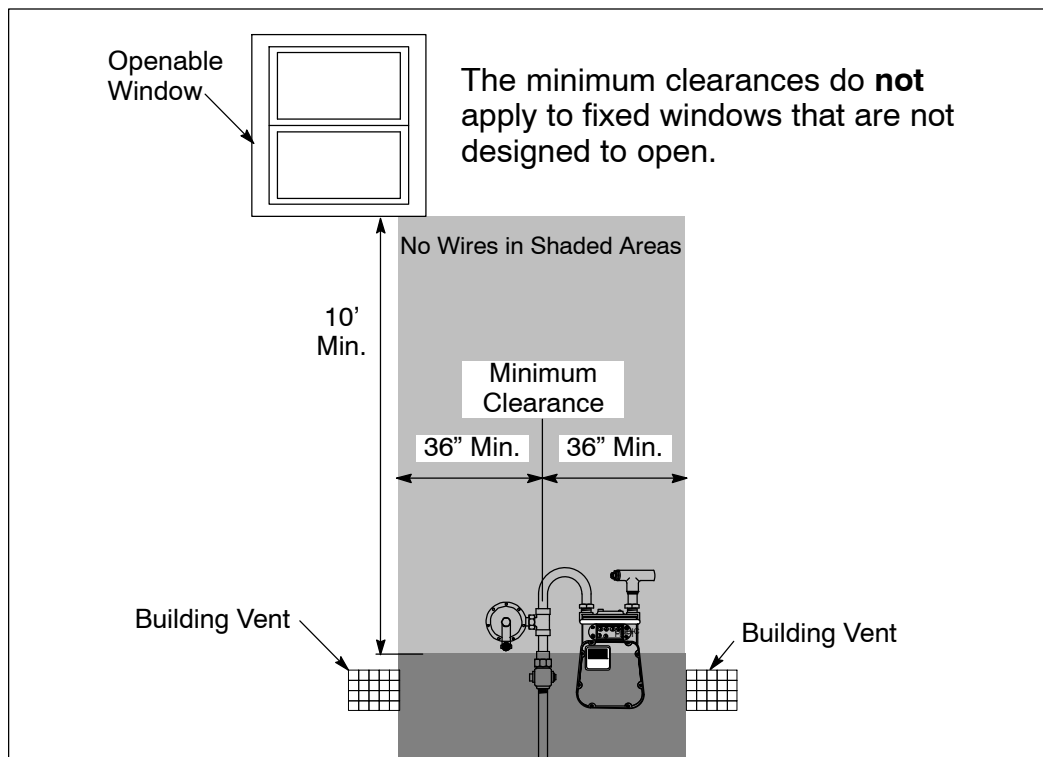

Figure 2-20
Gas Meter Set Clearance From Building Openings

Notes in reference to Figure 2-20.

1. Do **not** place gas regulator vents under display platforms or show windows in commercial buildings. This includes any permanent, elevated display floors or platforms associated with the window, where the purpose of the window is to present a display to the public.
2. Do **not** place gas regulator vents under building overhangs where the overhang is likely to direct venting gas to a building opening.
3. The building vent openings, sources of ignition, and above-ground water sources must be a minimum of 36 inches away from the riser.
4. Applicants must not install water spigots, lines, gutter systems, or other above-ground sources within 36 inches of the gas or electric facilities.
5. For a large meter or multi-meter manifold, the minimum separation requirement for sources of ignition, opening to buildings or sources of above-ground water, extend 12 inches beyond the farthest connection to the applicant houseline, and 10 feet above the highest regulator vent.

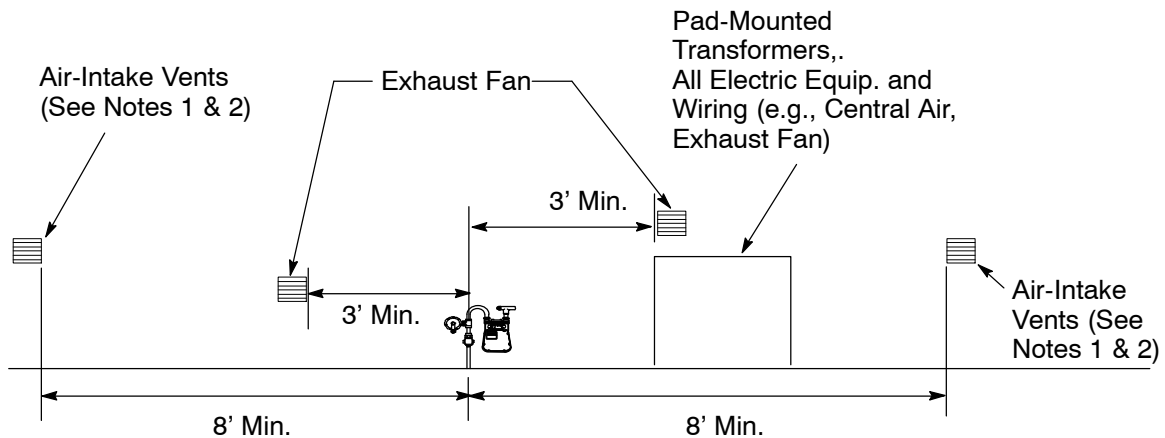

Figure 2-21
Gas Regulator Set Clearance Requirement from Sources of Ignition

Note in reference to Figure 2-21.

1. An 8-foot minimum horizontal and 10-foot minimum vertical clearance is required from the gas service riser to combustion air-intake vents and forced air-intake vents.
2. For a large meter set or multimeter manifold, this clearance requirement will extend 8 feet beyond the farthest PG&E meter equipment.

E. Multimeter Manifolds

Specific requirements in this subsection apply to particular types of premises (e.g., multifamily, apartment, and commercial buildings) where multiple meters are installed at a single location using the manifold configuration. These manifold connection requirements are additions to the meter-set requirements for single gas meter sets.

PG&E limits gas meter manifold configurations to one-tier or two-tier meter manifolds not exceeding 60 inches high. These manifolds are measured from the final, level, standing surface to the top of the manifold.

NOTE: Applicants must provide their PG&E project coordinator with a written justification for approval when requesting a three-tiered manifold or a manifold greater than 60 inches high.

PG&E will assess the applicant's site and conditions for gas service lateral and metering installations before approving an installation site.

Refer to [Gas Design Standard J-15](#), located in [Appendix C](#), for additional information.

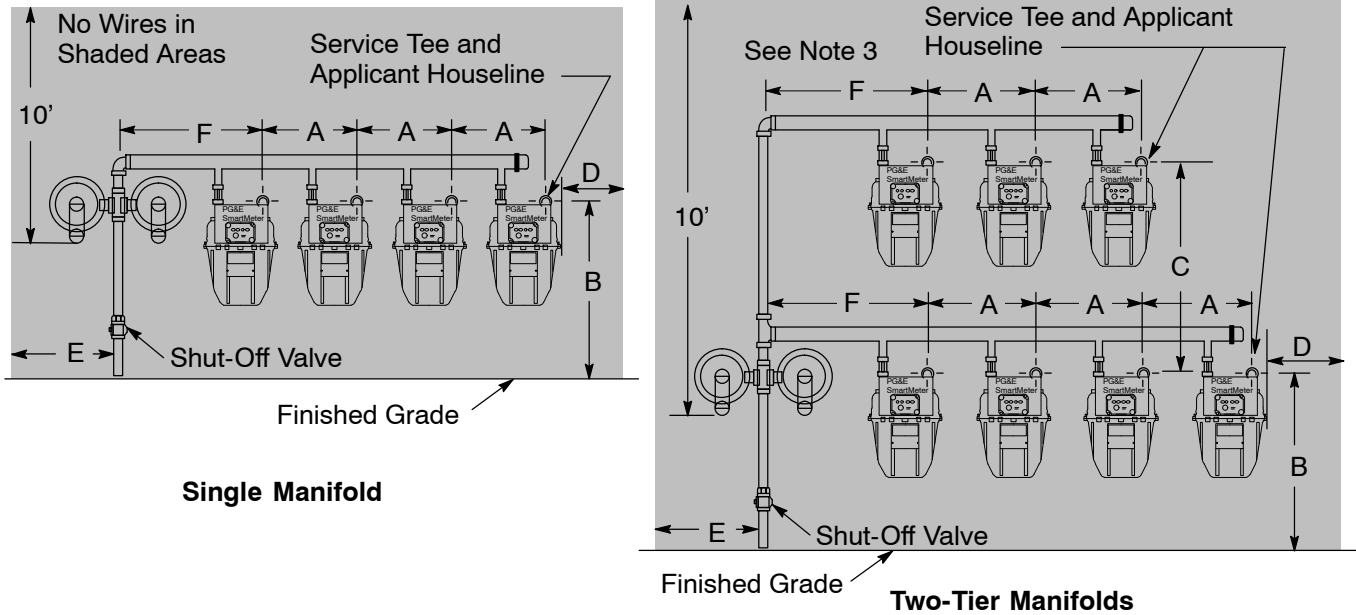

Figure 2-22
Dimensions for Typical, Residential, Multimeter Installations

Table 2-2 Dimensions to Figure 2-22

Dimension	Installation	Comments
A	12" for residential only 15" for cabinet installations only 20" for all commercial up to 1,000 class meters	PG&E provides custom-design dimensions for mixed meter sizes and for larger than 1,000 class meters.
B	26" (typ.) for unenclosed 32" (typ.) for cabinet installations	-
C	24" residential (unenclosed and cabinet) 36" commercial	Contact your local project coordinator for two-tier commercial manifolds.
D	6" min. to inside building corner 12" min. to outside building corner 36" minimum to electrical wires (see Note 3)	From farthest edge of PG&E equipment.
E	30" minimum to inside or outside corner of building 36" minimum to electrical wires (see Note 3)	PG&E may approve Dimension E to be reduced on a case-by-case basis. For example, in non-pedestrian traffic areas and on select PG&E equipment.
F	24" (typ.) for residential 36" (typ.) for 400 to 1,000 class meter, commercial	PG&E provides custom-design dimensions for mixed meter sizes and for larger than 1,000 class meters.

Notes in reference to Figure 2-22

1. The applicant's houselines must be stubbed out 4 inches to 6 inches from the finished wall at the locations shown.
2. The applicant must clearly mark each houseline. See Subsection 2.4.2.G.9., "Meter-Set Requirements for Marking Houselines," on Page 2-41.
3. Applicants must **not** install any electrical devices or equipment, including wires, cables, metering enclosures, telecommunication enclosures, **bond wires, clamps, or ground rods** within 36 inches horizontally from the farthest edge of PG&E facilities and 10 feet above the regulator vent.
4. Applicants may need to install the riser farther away from the building to accommodate the manifold installation. Consult your local project coordinator for site-specific details.

F. Requirements for Gas Meter Cabinets Gas Meter Rooms, Enclosures, and Closets

1. General Requirements for Meter Cabinets

Gas cabinets are not preferred and require PG&E's approval in advance of construction as described in [Gas Design Standard J-15](#), located in [Appendix C](#). Applicants must ensure that all related vent openings, louvers, and/or viewing windows are installed correctly. Also, applicants must ensure that the cabinets open to the outside and are readily accessible to PG&E at all times. Refer to [Gas Design Standard K-51](#), "Single Meter Cabinet for Domestic Gas Meters," located in [Appendix C](#), for more information.

Typically, the gas meter size represented in Figure 2-14, "Typical Residential Gas Meter Connection," located on Page 2-27, can be installed in a cabinet. On a case-by-case basis, PG&E may allow an applicant to install a gas meter the size of the one illustrated in Figure 2-15, "Typical Gas Meter Connection for 400 to 1,000 Class Meter," located on Page 2-28, in a cabinet; however, **this exception requires PG&E's approval before construction.**

A gas estimator must provide the cabinet spacing and size requirements, which then must be approved by a Field Service Manager. Based on working space requirements, the meters may require installation in a meter room.

2. Specific Requirements for a Single Gas Meter Cabinet

PG&E determines the minimum cabinet size allowed for an applicant's specific type of meter and provide the applicant with those dimensions. PG&E bases cabinet requirements not only on the size of the meter currently required, but also on the location and accessibility of the meter. See [Gas Design Standard K-51](#), located in [Appendix C](#), when determining the specifications for single gas meter cabinets.

3. Specifications for a Recessed, Individual Meter Cabinet

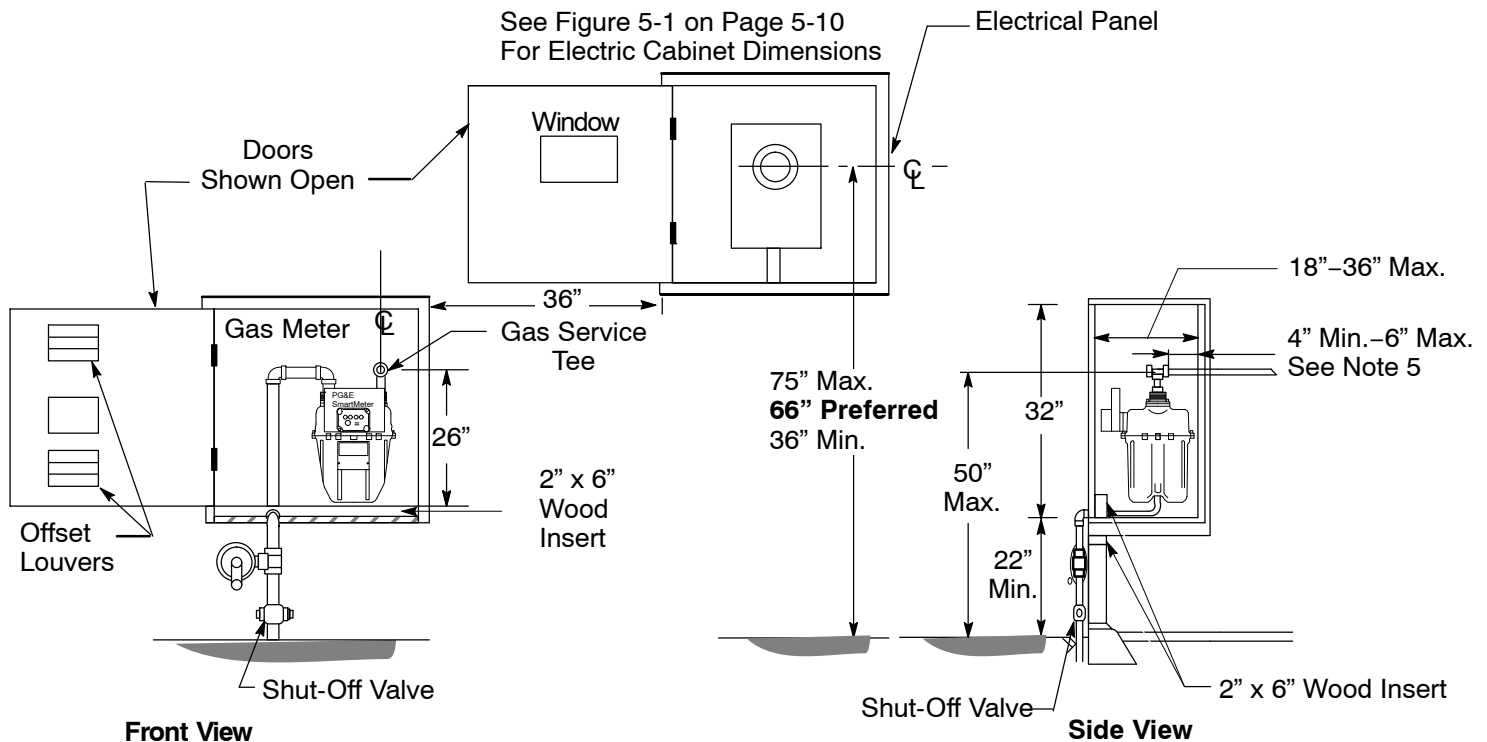

Figure 2-23
Recessed, Individual Meter Cabinet for Gas and Electric Meter Installations

Notes in reference to Figure 2-23.

1. Meter cabinets are not a preferred method of installation. Meter cabinets, with the exception of Class 200 meter installations, require approval from the local Field Services Manager before construction begins. When approved, they must comply with the requirements in this section.
2. Regulators should be installed on the outside of the cabinet. Additional space is required for larger regulators and dual-head regulators. The local Field Services Manager may approve the regulators to be installed in a cabinet. Regulators installed in a cabinet require the vents to be piped out as described in [Gas Design Standard H-93](#), "Regulator Vent Lines—Above Ground."
3. The cabinets shown are for typical meter installations. PG&E determines the minimum size of the required enclosure when the meter's location is established.
4. See Subsection 2.5.1., "Service Delivery Point For the Gas Supply," on Page 2-44. The houseline at the service delivery point also must be reinforced so that it can provide support for the meter set piping. The pipe must be rigid, a minimum of 3/4 inches, and have tapered pipe threads.
5. The houseline must extend a minimum of 4 inches and a maximum of 6 inches into the gas meter cabinet measured from the finished wall. The houseline must be 32 inches above the bottom of the meter cabinet.
6. Applicants must provide fully louvered, non-metallic doors. Each door must open at least 90°. This supersedes the requirements of [Gas Design Standard K-51](#).
7. Applicants must install the gas service riser **before** any concrete or paving work occurs. After the gas service riser is installed, the applicant must ensure that there is a sleeve in the concrete or paving at least 3 inches in diameter, unless otherwise specified, for the gas service riser.
8. The gas meter cabinet must have a gas-tight seal and be vapor proof from the building. Construction material and sealing requirements for the cabinet are described in [Gas Design Standard K-51](#), located in [Appendix C](#), and also apply to Figure 2-23.

Notes in reference to Figure 2-23. (continued)

9. Applicants must ensure that gas meters installed in cabinets comply with the requirements of the inspection authority having jurisdiction.
10. Do **not** place electric meter panels, equipment or devices, conduit or wiring, enclosures, or connections within 36 inches of the gas riser. Including for services such as cable television or telecommunications.
11. Refer to the requirements in *Greenbook* [Section 5](#), [Section 6](#), and [Section 7](#) for wall-mounted electric meter panels and cabinets.

4. Specific Requirements for a Multiple Gas Meter Cabinet

Requirements for multiple, residential, gas meter cabinets are essentially the same as those for single gas meter cabinets, as outlined in Subsection 2.4.2.F.2., “Specific Requirements for a Single Gas Meter Cabinet,” on Page 2-36.

Figure 2-24, “Cabinet Dimensions for Multiple, Residential Gas Meters,” shows the dimensions and details for a multiple gas meter cabinet.

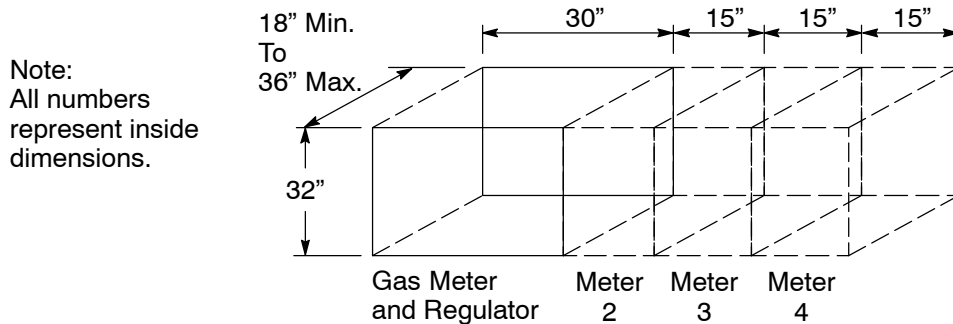

Figure 2-24
Cabinet Dimensions for Multiple, Residential Gas Meters

5. Gas-Meter Closets

Gas meter closets will be furnished and installed by the applicant and have a depth of 18 inches minimum and 36 inches maximum without exception. Doors must be non-metallic and fully louvered. Doors must open at least 90° and have a clear opening height of 6 feet, 8 inches tall.

The inside of the closet must be made of non-flammable material and have a minimum 1-hour fire rating. All joints and penetrations must be sealed to prevent gas from migrating into the structure.

Foreign pipes are not allowed inside the closet with the exception of fire sprinkler heads. Lighting, wiring, conduits, junction boxes, or inspection panels of any kind are not allowed inside the closet. Bonding or grounding wires on the customer’s houselines are not allowed inside the closet.

The ceiling must have a 1:12 slope. The ceiling must slope up toward the door frame with a maximum of 6 inches measured from the door opening to the finished ceiling. The inside width of the closet cannot exceed 8 inches beyond either side of the door frame. Refer to Figure 2-22 on Page 2-35 for manifold spacing to determine the size of closet required for the desired number of meters. The meters and manifold must fit within the opening of the closet doors with the exception of the tie-in piece from the outside riser. The riser and regulator will be installed outside of the closet.

The applicant provides a penetration through the wall into the closet. Contact your local project coordinator for the exact size and location of the required penetration.

The doors must have sign identifying “Gas Meters.” If the doors have locks, the applicant must install a lock box near the closet that is acceptable to PG&E and contains a key.

The closet cannot be used for storage of any kind. Only PG&E gas meters and metering appurtenances are allowed inside the closet.

6. Specific Requirements for Gas Meter Rooms

Refer to [Gas Design Standard J-16](#), located in [Appendix C](#), for specific requirements about gas meter rooms.

7. Gas Meter Set Enclosures

a. Typical Enclosure Details

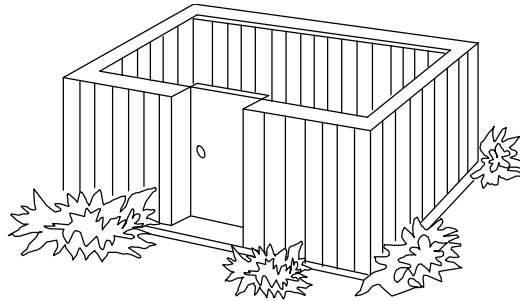
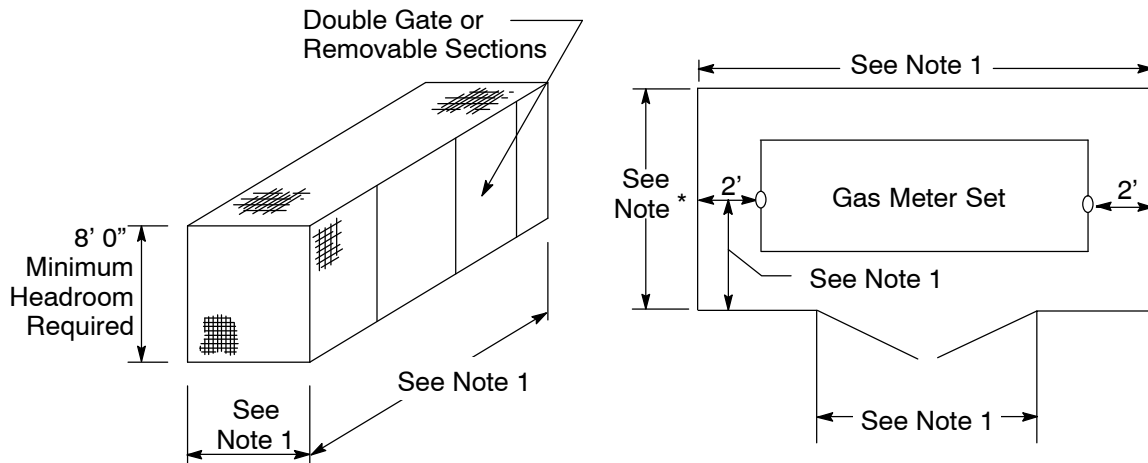

Figure 2-25
Typical Detached Enclosure



**Figure 2-26
Typical Enclosure Dimensions**

Notes in reference to Figure 2-25 and Figure 2-26.

1. The enclosure's length will vary depending on the meter set. Contact your local PG&E project coordinators for more information.
2. PG&E determines if the enclosure requires a wire mesh cover. If a mesh cover is required, it must have a minimum 50% open area.
3. Approved enclosure materials include, but are not limited to, concrete block, wood, perforated or expanded metal, or metal chain-link fencing.
4. For enclosures with a cover and alcoves with a gate, the material used must have a minimum 50% open area. For example, perforated metal sheets have specific percentages of open area.
5. All distances provided in Figure 2-26 are minimums. After PG&E confirms the meter size, final dimensions will be provided.
6. Trucks must be able to access large meter installations. Please contact your local PG&E project coordinator before designing locations for gas meters.
7. Additional meter protection may be required. Protection posts can be incorporated into an enclosure design.

b. Special Requirements for Gas Meters Serving Schools or Other Buildings Where Children Congregate

The following requirements apply to schools or other buildings where children congregate.

- Locate the gas meter enclosure adjacent to the property line or away from buildings in a wire cage enclosure or other suitable protective enclosure.
- PG&E requires an overhead wire cover to prevent any debris or other material from falling inside the enclosure.
- The applicant must ensure that PG&E is able to secure the enclosure with a PG&E lock.
- It is the applicant's responsibility to provide the enclosure and concrete pad for the gas meter set. PG&E must approve the final design and size of the enclosure.

8. Meter Protection Requirements

Applicants must protect meter sets in locations that are subject to damage from vehicular traffic. PG&E determines when such protection is required. Refer to [Gas Design Standard J-95](#), located in [Appendix C](#).

Applicants must protect all gas meter sets located in the following areas.

- a. Within 3 feet of:
 - Single-family, residential driveways or parking areas (including garage areas)
 - Commercial refuse container locations
 - Thoroughfares
 - Paved areas with curbs
- b. Within 8 feet of:
 - Multifamily, commercial, or industrial driveways or parking areas (see the “Exception” below)
 - Loading docks
 - Freight-handling areas
 - Thoroughfares
 - Paved areas without curbs

EXCEPTION: Physical protection is **not** required for meter sets located within 8 feet of multifamily, commercial, or industrial driveways or parking areas if the meter set is located 3 feet behind a barrier that is adjacent to the area and if PG&E finds the barrier to be acceptable.

- c. Within an area that has, in PG&E’s judgement, an unusually high risk of vehicular damage, the applicant must install a system of barrier posts that meet PG&E’s specifications. Consult your local project coordinator for specific requirements.

9. Meter-Set Requirements For Marking Houselines

Applicants must ensure that the following rules for marking houselines are followed.

- a. PG&E requires that lines are marked by attaching an embossed, durable, metal or plastic tag to each houseline. PG&E must approve of the tag.
- b. Markings **must** be legible and specific.
- c. Marking information must include an authorized apartment or street number and a use or location designation.

- d. The houseline must be permanently, clearly, and prominently marked **at the point of the service connection** (i.e., service delivery point).

NOTE: PG&E will **not** install meters unless the permanent address, the location, or, when applicable, the area being served is marked at each meter location.

- e. When gas meters are installed in interior locations or rooms, the words “Gas Meters” must be placed on the room or location access doors to allow PG&E employees to find the meters easily.

10. Meter Sets Requiring Telephone Service

Applicants with an estimated average use of 10,000 therms per month or more are required to install, own, and maintain a nominal, 1-inch diameter conduit and a telephone cable. This requirement also may apply to applicants with select rate schedules, Automated Meter Reading (AMR), and noncore accounts. PG&E’s requirements for the conduit are described below.

- a. Applicants must extend the conduit and telephone cable from the closest telephone service location to a location specified by PG&E at or near the gas metering facilities. Applicants must install an approved ground rod at a PG&E-specified location.
- b. Applicants are responsible for all charges and costs associated with installing the telephone facilities necessary to provide telephone service for PG&E’s gas metering purposes.
- c. PG&E is responsible for establishing telephone service and for the ongoing telephone service charges for gas metering purposes.
- d. When in a meter room, install the conduit and associated equipment as shown in [Gas Design Standard J-16](#), Figure 1, “Gas Meter Room Electric Enclosure and Conduit Arrangement,” located in [Appendix C](#).

11. Gas Pulse Metering

Refer to Gas Standard J-65.1, “Volume Pulse Output Connection for Gas Meters,” located in [Appendix C](#), for specific requirements about gas pulse metering.

12. Additional Meter-Set Requirements—SmartMeter™ Module Location Requirements

PG&E's SmartMeter™ Advanced Meter Reading system uses radio frequency (RF) technology to transmit gas meter reads automatically. This allows PG&E's customers to monitor their daily energy use.

SmartMeter™ customers have additional location requirements specific to the meters necessary for PG&E to operate its SmartMeter™ Advanced Meter Reading system. Applicants must be aware of the following requirements to ensure that the SmartMeter™ Advanced Meter Reading system can operate properly.

- a. **Do not** locate the meters in any room, cabinet, enclosure, or configuration that blocks or interferes with the radio frequency signal transmissions. An example of such a prohibited enclosure is a metallic cabinet.
- b. **Do not** locate the meters in close proximity to (i.e., 6 inches or less) any metallic object that could block or interfere with the radio frequency signal transmission.
- c. **Do not** install gas meters within 5 feet of building walls and ceilings if they are made from a significant amount of metal or metal reinforcements.
- d. Most SmartMeter™ gas modules are installed directly on a gas meter. If a gas meter is installed in a cabinet, meter room, below grade, basement garage, or other location where communication problems may exist, PG&E may install a module in a remote location away from the gas meter to ensure proper radio frequency transmissions. The equipment may be installed on nearby gas piping, a customer-owned building wall/ceiling, or an outside location. The equipment may need to be attached to the structure or wall to route the wiring.

2.5. Applicant-Owned and Installed Gas Service Piping (e.g., Houseline), Valves, and Automatic Shut-Off Devices

The applicant is responsible for maintaining the applicant-installed and owned gas service piping, valves, automatic shut-off devices (e.g., earthquake valves), or other piping components on any premises or in any building. These applicant-owned components must be installed downstream of (i.e., after) the gas supply service delivery point. PG&E reserves the right to suspend service until applicant-owned equipment is removed from PG&E meter-set assemblies.

Applicants must ensure that after their equipment is installed, the equipment does **not** obstruct the operation or serviceability of PG&E's piping, metering, and pressure-regulating equipment.

The houseline at the service delivery point typically is located after the PG&E service tee for residential services. Reinforce the houseline so that it provides support for the meter-set piping. The pipe must be rigid, must be a minimum of 3/4 inches, and must have tapered pipe threads.

2.5.1. Service Delivery Point For the Gas Supply

The service delivery point for the gas supply is the point where PG&E's facilities connect to the applicant's house pipe (i.e., houseline). Figure 2-1 on Page 2-6 illustrates a typical service delivery point.

For **residential** and **small commercial** meter sets, the service delivery point is the point where the male threads of the applicant's houseline connect to the female threads of PG&E's gas service tee fitting.

Some **commercial** installations and **industrial** installations do **not** have service tees installed. For these installations, the gas supply service delivery point is located after the gas meter, gas pressure regulator, or regulation equipment. Specifically, it is the point where the gas service bypass reconnects with the gas service outlet piping.

Typically, the gas supply service delivery point is either the first weld or fitting after the PG&E-installed bypass valve downstream of (i.e., after) the gas meter. See Subsection A in Figure 2-16 through Figure 2-18 on Page 2-29 through Page 2-31.

PG&E does **not** allow applicants to access the pipe fitting's plug. Only PG&E employees are authorized to access the plug when they perform service and maintenance.

Applicants must **not** connect or install non-PG&E components to any portion of the PG&E gas meter set upstream of (i.e., before) the service delivery point.

Applicants must provide a securely supported gas houseline connection to PG&E piping either by bracing or by reinforcing the houselines that extend from finished walls. Do **not** connect flexible houseline directly to PG&E piping. (Exceptions include subsidence areas, mobile home parks, and manufactured homes as described in [Gas Design Standard J-12.4](#) and [Gas Design Standard J-58](#).)

When applicants require a gas supply for multiple gas meter installations that are supplied by a manifold, PG&E will install gas service tees downstream of (i.e., after) each gas meter. PG&E will install these service tees to each location where the utility gas service pipe connects to the applicant's houseline at the service tee.

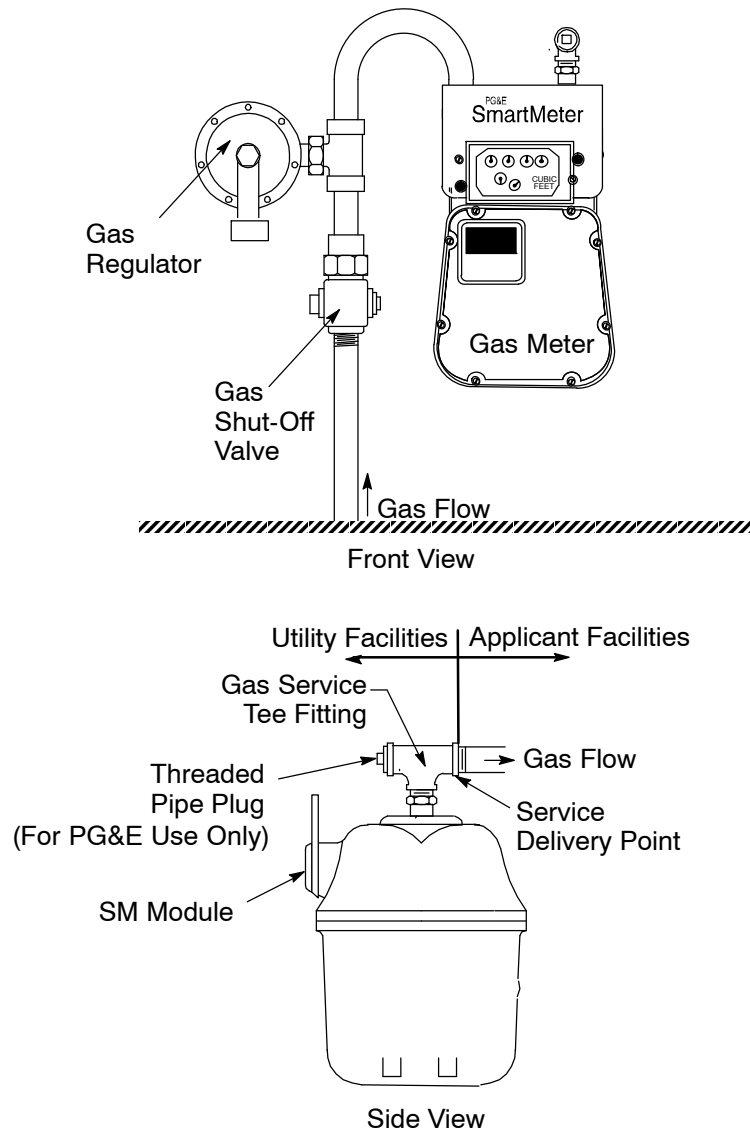

Figure 2-27
Typical Residential, Multimeter Installations

2.5.2. Applicant-Owned Riser and Pipe

PG&E recommends that applicants use the gas-riser configuration shown in Figure 2-28, “Recommended, Applicant-Owned Riser and Pipe,” found on Page 2-46, when they install above-ground gas pipe that transitions to underground gas pipe. The preferred riser for most applications is a noncorroding, prefabricated riser.

Also, PG&E recommends that applicants contact the local authority having jurisdiction before installing ferrous gas pipe and ask for the requirements to protect the underground pipe from corrosion.

- A. Applicants are encouraged to have all buried gas pipe inspected yearly. Applicants should contact locally licensed plumbing contractors if they need assistance in locating, inspecting, or repairing their buried gas service pipe or other piping equipment.
- B. Applicants must ensure that all required cathodic protection is in place and documented as illustrated in Figure 2-28 below.
- C. Applicants must ensure that their facilities are designed and installed to the requirements of the governmental authorities having jurisdiction. PG&E recommends using the [Uniform Plumbing Code](#), which requires the following protective measures.
 1. Apply a coating and cathodic protection to steel pipelines.
 2. Repair any coating that is damaged during installation.
 3. Install copper tracer wire with nonmetallic gas pipe.
 4. Provide a minimum cover of 18 inches for plastic yard pipe used to carry gas.

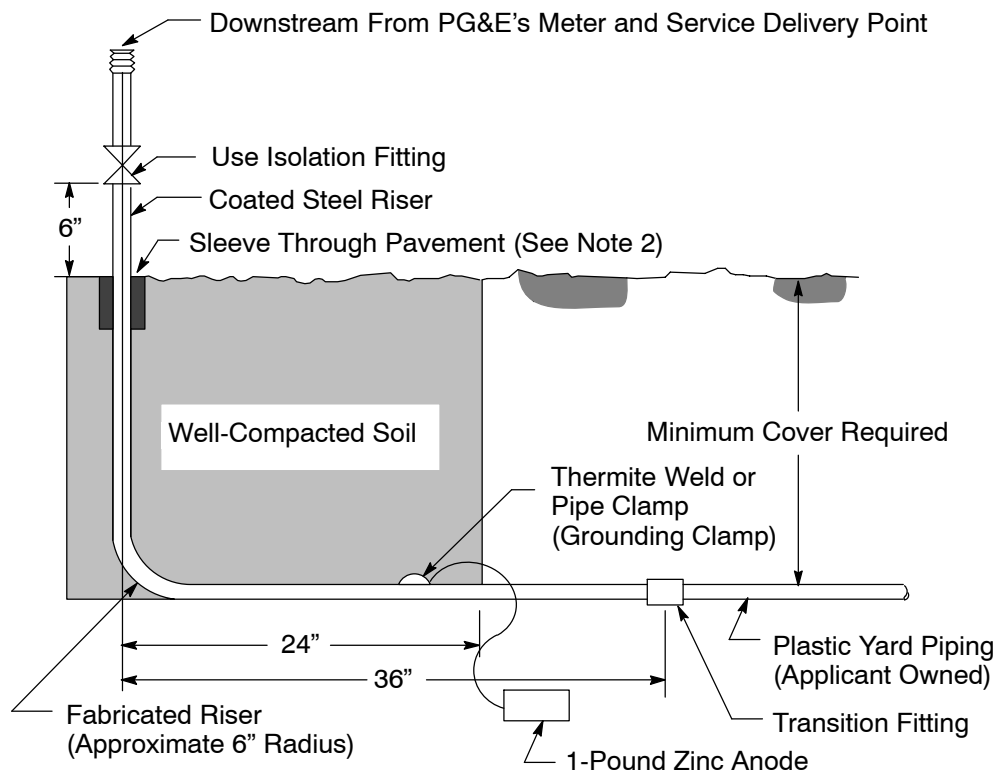

Figure 2-28
Recommended, Applicant-Owned Riser and Pipe

Notes in reference to Figure 2-28.

1. Always maintain a minimum distance of 36 inches between the vertical centerline of the riser and the transition fitting.
2. If the area around the gas riser is going to be paved, install a minimum 3-inch sleeve around the riser.
3. Comply with city regulations when installing a plastic-to-steel riser (as shown) or a noncorroding, prefabricated riser on the applicant's houseline.

2.5.3. Electrically Bonding and Grounding Gas Pipe

- A. Do **not** install electrical devices or equipment, wires, cables, bonding or grounding wires, clamps, or ground rods around the gas meter set as shown in Figure 2-19 on Page 2-32 and Figure 2-22 on Page 2-35.
- B. Do **not** use PG&E's gas service piping, gas risers, or meter facilities for electric bonding or grounding that allows the gas meter, piping, or other gas facilities to become current-carrying conductors.
- C. Do **not** allow gas pipe to be electrically bonded within meter enclosures, cabinets, or meter rooms.

2.5.4. Applicant-Owned Protective Equipment

PG&E's gas metering equipment can be affected adversely when an applicant's equipment causes:

- Pulsations in the gas flow
- Sudden changes in flow rate
- A backflow condition

Applicants must install, at their expense, any equipment necessary to mitigate or eliminate these detrimental effects. PG&E must review and approve these installations before initiating gas service.

Applicants must add any necessary protective equipment when their operations change and those changes could create any of the three adverse conditions described in the previous bulleted list.

PG&E may terminate service and refuse to restore that service to any applicant who continues to operate without the proper protective equipment after receiving notification from PG&E.

Applicants are responsible for damages made to PG&E equipment because they did not install the proper protective equipment.

This Page Intentionally Left Blank

**SECTION 3
ELECTRIC SERVICE:
UNDERGROUND**

SECTION 3 ELECTRIC SERVICE: UNDERGROUND



Know what's below.
Call before you dig.

Section 3 Electric Service: Underground

3.1. Scope

This section of the manual provides information to help applicants, as well as their engineers and contractors, select acceptable locations and types of terminations for underground services when connecting to Pacific Gas and Electric Company's (PG&E's/Company's) overhead or underground electric distribution system.

NOTE: For technical information on primary services, refer to [PG&E Bulletin TD-2999B-030](#), "Technical Requirements for Electric Service Interconnection at Primary Distribution Voltages," in [Appendix B](#), "Electric and Gas Service Documents." For temporary or permanent service to a post or pedestal, refer to the applicable documents in [Appendix C](#), "Electric and Gas Engineering Documents."

3.2. General Information

PG&E has the right to access Company facilities located on an applicant's premises at any time, for any purpose connected with furnishing gas and/or electric service. Applicants must **not** access PG&E facilities or enclosures. Only qualified PG&E employees will connect service lateral conductors to (or disconnect them from) PG&E's energized distribution system. This includes installing or removing metering facilities or any other work related to PG&E's facilities or systems.

3.2.1. Safety Reminder



WARNING

To avoid potential accidents, do *not* begin to excavate before identifying underground facilities.



CAUTION

Flame resistant (FR) clothing is required while working on, working near, or observing others working on any PG&E facility.

State law requires applicants to contact [Underground Service Alert \(USA\)](#) by dialing **811 at least 2 working days before excavation** (weekends and holidays excluded). Ensure that you call USA when planning underground work, before digging begins, to allow adequate time for USA to determine the location of underground gas and electric lines or equipment. ***The potential for an accident exists if applicants fail to request USA to identify underground utility facilities before they begin excavating.***



USA



Dig Safely

First, the applicant must mark the excavation area with white paint. Then, USA will arrange for participating companies to mark the locations of their underground facilities at the jobsite. **This is a free service.** See the USA color-code identifiers on Page 1-1 and on the back of this manual.

Additional information is available at www.pge.com/digsafely and about USA services at the USA North website <http://www.usanorth.org>. USA is a locating service for excavation only. Do not use USA for design purposes.

3.2.2. Establishing Underground Electric Service Responsibilities

Applicants are responsible for constructing, maintaining, and protecting specific portions of underground electric services during construction of their project. The following subsections describe those responsibilities and explain PG&E's responsibilities during the construction process.

- A. Applicants are responsible for obtaining all required **permits**. This includes local building permits, environmental permits, encroachment permits, and any other permits that may be required based on the specific location of the trenching/excavation activities.
- B. Applicants must ensure that the following construction activities, which may be required to establish underground service, are performed according to PG&E's standards and specifications, PG&E-approved construction drawings and inspection requirements, and any other permit-specified requirements. This includes construction activities conducted on private property, in the franchise area, or in other right-of-way areas. Construction activities include:
 - Trenching
 - Excavation
 - Backfill
 - Compaction
 - Conduit
 - Substructures (boxes and pads)
 - Paving (cut, patch, and final repair)
- C. Applicants must provide satisfactory termination facilities on or within the structures being served. (In this manual, see Sections [5](#), [6](#), [7](#), [8](#), [9](#), [10](#), and [11](#), as applicable, based on your project type, amperage, and voltage.) The locations for all transformers and meters, as well as the sizes, types, and quantities of conduit, are subject to PG&E's specifications and approval.
- D. Applicants are responsible for owning and maintaining conduit and substructures on private property; however, they must convey ownership of any portion in a public (i.e., franchise) area or right-of-way, if applicable, to PG&E.
- E. Applicants are responsible for providing, installing, and maintaining any structures that are required to protect service facilities from damage.

F. **PG&E is responsible for and required to perform any and all tie-in work to existing distribution and/or energized facilities.**

G. PG&E is responsible for furnishing, installing, owning, and maintaining the following service facilities, as applicable. For additional details and options for performing this work, refer to [Electric Rule 15](#), “Distribution Line Extensions,” and [Electric Rule 16](#), “Service Extensions,” found online at <http://www.pge.com/tariffs/ER.SHTML#ER>.

- Cable/conductors to supply power
- Transformer
- Meter(s) and metering transformers, if required
- Other equipment (e.g., switches)
- Riser materials (to connect underground service to overhead facilities)

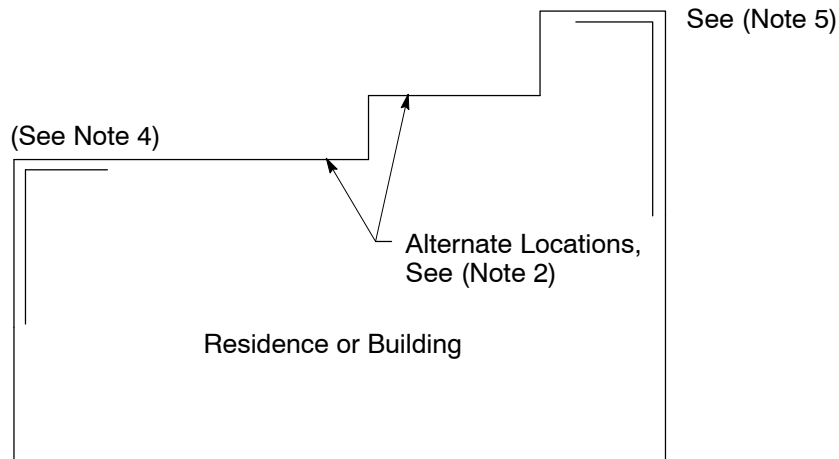
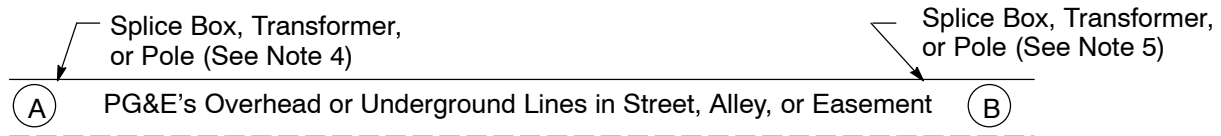

- ===== Walls on which underground electric service-termination and meter facilities are permitted.
- Outside building walls.

Figure 3-1
Locations of Underground Electric Service-Termination and Meter Facilities

Notes in reference to Figure 3-1.

1. If practical, attach the underground electric service-termination facility and the meter to the wall at a preferred location. Locate the facilities as close to PG&E's service facilities as possible to avoid future operation and maintenance restrictions.
2. **PG&E must approve all service locations before they are constructed.**
3. Applicants must locate the service so that the meter can be read and serviced **without** entering a fenced or enclosed location, when possible.
4. Permitted locations for electric service-termination and meter facilities are from Point A.
5. Permitted locations for electric service-termination and meter facilities are from Point B.

3.2.3. Installing Ground Rods

Applicants or their contractors are required to install ground rods when PG&E specifically requires them as part of a substructure installation (e.g., when constructing a transformer pad). Find PG&E-approved ground rods and clamps in [Numbered Document 013109](#), “Corrosion Resistant Ground Rods and Ground Rod Clamps,” included in [Appendix C](#).

3.2.4. Installing Equipment Pads

Applicants or their contractors must construct and install equipment pads, as required, for electric equipment that is providing underground electric service. When constructing a concrete pad for a transformer, use [Numbered Document 045292](#), “Concrete Pad for Three-Phase, Loop-Style, Pad-Mounted Transformers.” If installing a box pad for a transformer, use [Numbered Document 064309](#), “Box-Pad for Pad-Mounted Transformers.” Both engineering documents are listed [Appendix C](#).

For projects that require equipment pads other than for transformers (e.g., PMH switches), these drawings are provided by your project coordinator or PG&E inspector at the pre-construction meeting if the installation is included in the PG&E-approved design.

Install customer-owned switchboard pads according to their applications. Refer to the ground rod and conduit requirements for primary switchboards in [Section 11](#), “Electric Switchboards: 601 Volts Through 25,000 Volts and Primary Services,” Subsection 11.3.S., on Page 11-3, and Figure 11-1, “Primary Switchboard Termination Section Pad Detail,” on Page 11-4.

For additional references to the underground electric documents provided in [Appendix C](#), see Table 3-2, “Electric Underground Documents,” on Page 3-14.

3.2.5. Installing Overhead and Underground Service for Two or More Buildings on One Lot

If more than two dwellings or buildings are located on the same lot, applicants must consult their local PG&E project coordinators to determine the acceptable service-termination locations and meter locations **before** wiring the buildings.

NOTE: See [Table FM-1, “Service Planning Office Contact Information.”](#) at the front of this manual starting on Page iv, for specific contact numbers listed by area.

Typically, PG&E only installs one service lateral to a single building on one premise, or to a single enterprise (with either one or multiple buildings) on one premise. However, PG&E may provide more than one service lateral under the following circumstances.

- A. Where it is allowed or required by PG&E’s tariff schedules.
- B. For PG&E’s convenience.
- C. Where it is required by ordinance.
- D. When it is installed as special facilities.

3.2.6. Inspecting and Approving Overhead and Underground Services

An applicant must contact the local PG&E project coordinator to arrange for a field representative to inspect and approve the applicant-furnished and installed service equipment, as well as any other mandatory components required for an underground service installation.

3.3. Underground Service Installation Requirements

3.3.1. Installing Services From Underground Distribution Systems

PG&E serves applicants from an underground service if the site or lot is located in an area that is supplied from an **existing** underground distribution system. PG&E owns, maintains, and installs the underground service lateral conductors. PG&E provides underground-to-underground service **along the shortest, most practical, and most available route** to the applicant's service-termination facility.

Typically, the termination facility is on or within the building or structure, as shown in Figure 3-2, "Underground-to-Underground Service Connection," below. PG&E will install the conductors in conduit.

Substructures include conduit, boxes, and transformer pads. Applicants must follow PG&E's guidelines and specifications, including those specified in [Electric Rule 16](#).

PG&E installs the transformer, if required, and connects the service lateral conductors to the applicant's termination facilities.

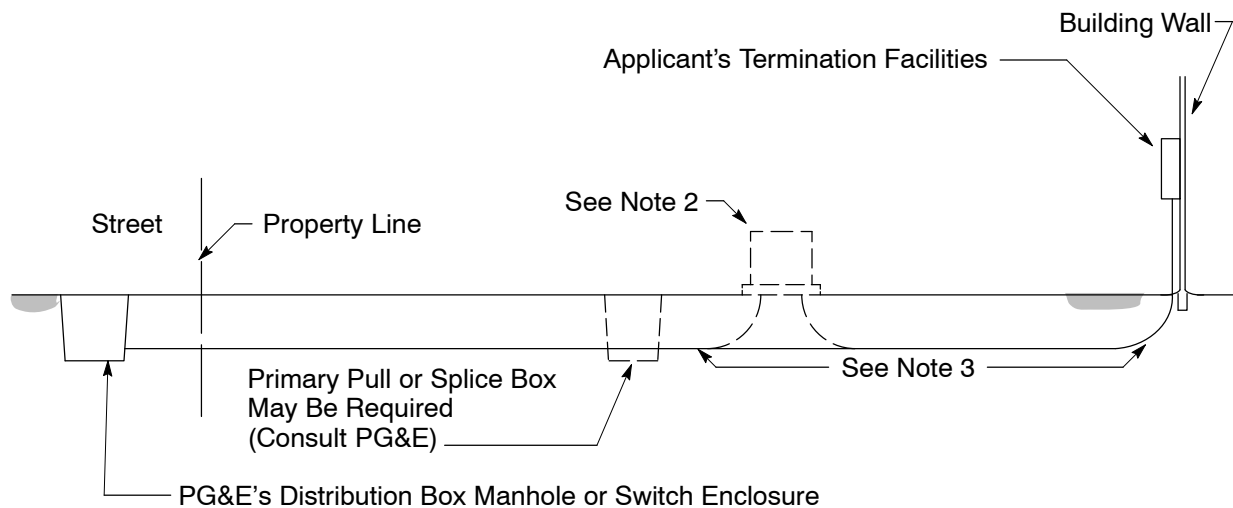

Figure 3-2
Underground-to-Underground Service Connection

Notes in reference to Figure 3-2.

1. When the service delivery voltage is the same as the available, primary distribution voltage (i.e., over 2,000 volts), typically the applicant provides a primary splice box according to PG&E's requirements.
2. PG&E supplies a transformer, if required. (The applicant must provide the trench, backfill, and required conduit, pad, and substructures.)
3. PG&E-owned primary and/or secondary conductors. (The applicant must furnish the substructures.)

3.3.2. Installing Services From Overhead Distribution Systems

PG&E will provide service from an underground riser that is installed on an **existing** pole, as shown in Figure 3-3, “Overhead-to-Underground Service Connection,” below, if **any** of the following requirements are met.

- A. The applicant is located in an area served from an overhead system and the applicant prefers to have the service installed underground.
- B. The applicant’s load requires a transformer that is 75 kilovolt amperes (kVA) or larger.
- C. A local city or county ordinance requires underground service.

In these cases, in addition to the requirements described in Subsection 3.3.1., “Installing Services From Underground Distribution Systems,” on Page 3-5, the applicant must pay the material costs of both the pole riser facility and any conduit that is required in the public right-of-way.

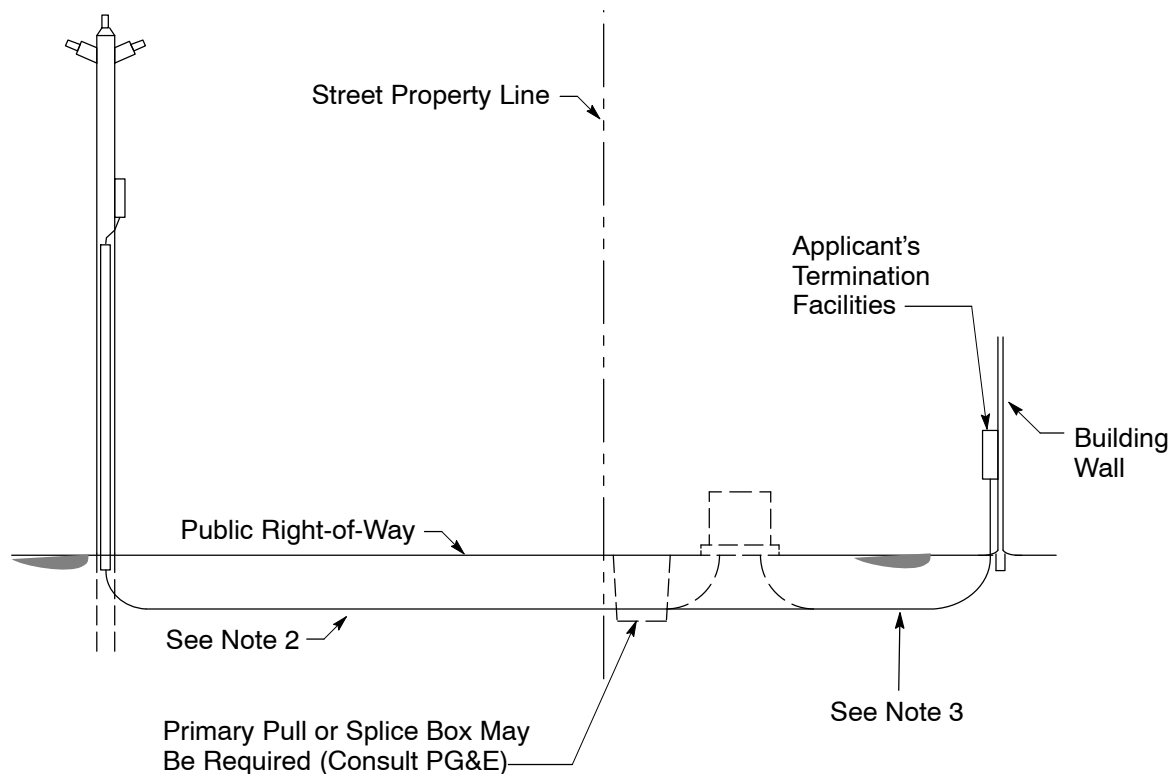

Figure 3-3
Overhead-to-Underground Service Connection

Notes in reference to Figure 3-3.

1. When the service delivery voltage is the same as the available, primary distribution voltage (i.e., over 2,000 volts), typically the applicant will provide a primary splice box according to PG&E’s requirements.
2. PG&E’s pole and secondary riser. (The applicant must pay the installed cost of the pole riser and conduit within the right-of-way.)
3. PG&E-owned service lateral conductors. (The applicant must furnish the conduit, as required.)

3.3.3. Installing Conduit for Underground Service

NOTE: PG&E will **not** install its supply cables in conduits that run beneath any building or structure when those conduits **do not terminate** on or within that building or structure, but are intended to supply **another** building or structure on the same or another premise.

PG&E requires applicants to install a conduit system for underground service laterals. It is the applicant's responsibility to provide service conduit as described in the following PG&E documents. Refer to the following numbered documents, located in [Appendix C](#).

- [Numbered Document 063928](#), “Methods and Requirements for Installing Commercial Underground Electric Services 0–600 Volts to Customer-Owned Facilities”
- [Numbered Document 063927](#), “Methods and Requirements for Installing Residential Underground Electric Services 0–600 V to Customer-Owned Facilities”
- [Numbered Document 062288](#), “Underground Conduits”
- [Numbered Document 038193](#), “Minimum Requirements for the Design and Installation of Conduit and Insulated Cable”

NOTE: It is recommended that applicants consider installing conduit one size larger than the required minimum in case larger cable is required or needed for future upgrades. Refer to Subsection 1.14., “Determining the Service Rating,” on Page 1-12, for information on how PG&E determines the ampacity (i.e., capacity) rating of customer equipment.

Also, applicants must ensure that conduit runs have a polyester pull-tape (Code 560154) to initiate the cable pulling. The pull-tape must be attached securely either to conduit plugs or caps.

Applicants must prove that the entire conduit system is free of dirt, rocks, or other obstructions that could prevent, hinder, or harm the installation of the electric conductors. Applicants must use a PG&E-approved mandrel to prove the conduit system. See Subsection 3.4.1., “Mandrels,” on Page 3-15, for details. A PG&E inspector must approve the equipment and the method, and observe the work being performed to prove the service conduit system's readiness.

Applicants must furnish and install either conduit caps or plugs on the ends of all conduits. In addition, at locations where the cable insulation may be damaged (e.g., transformer pads or switchboard pull sections), applicants are required to install cable protection at all of the conduit ends. Applicants should contact their local PG&E project coordinator for specific requirements.

3.3.4. Installing PG&E-Only Service Trenches

Applicants must ensure that trenches containing only PG&E electric service facilities or PG&E electric and gas service facilities are covered, as required, when those trenches are located on:

- Private property
- Designated sidewalks
- Parkways
- Driveways

The electric service conduit and gas pipe must be covered on private property or in the franchise as described in the following text. The required minimum clearances must be maintained as listed in Table 3-1, “Minimum Separation and Clearance Requirements for Service Trenches,” on Page 3-13.

- A. Provide a 24-inch minimum cover for secondary (i.e., 0–750 volts) electric service conduit and gas pipe.
- B. Provide a 36-inch minimum cover for primary (i.e., over 750 volts) electric service conduit.

The term “cover” refers to the standard distance between the outer surface of an underground facility and the final grade level. **The actual trench depth must be greater than the cover depth.**

All electric service and secondary conduit must enter PG&E splice boxes or enclosures from the bottom for new construction and not through the boxes’ conduit knockouts. **If** the top of the conduit is not at or below the required minimum conduit depths, the applicant needs to increase the installed depth of the conduit at those locations. See notes in [Numbered Document 028028](#), “Secondary Electric Underground Enclosures,” located in [Appendix C](#).

PG&E may require the applicant to provide other means of protecting the service conduit in the following circumstances.

- Increased traffic loading
- Soil erosion
- Open ditches
- Where digging machinery or equipment may be used

This increased protection also may be required in areas where similar situations either are anticipated or exist already.

Applicants must ensure that the trench depth is sufficient to meet the minimum depth requirements when taking into consideration the following conditions.

- A. The required depth of cover (as described previously).
- B. The size of the conduit that is being installed (e.g., 3 inch, 4 inch).
- C. The necessary bedding materials.
- D. The size of the electric conduit bends (e.g., 24-inch or 36-inch bends).

Therefore, for service trenches (e.g., secondary voltage and 3-inch conduit) on private property or in the franchise, the required minimum depth of trenches below grade is 30 inches.

Applicants must receive pre-approval from the PG&E inspector when requesting an exception to the minimum-depth requirements. Applicants should contact their local PG&E project coordinator with questions about trench depth.

Applicants should be aware that wet utilities must always be separated from the electric and gas service trench, meters, and risers. For more information, see [PG&E Standard S5453](#), “Joint Trench,” [Exhibit B](#), *Joint Trench Configurations & Occupancy Guide*, located in [Appendix B](#).

Also, when applicants plan to install electric service facilities with other services, such as telephone or cable television, they must refer to:

- Subsection 3.3.8., “Installing Joint Utility Service Trenches,” on Page 3-11.
- Figure 3-4, “Typical Joint Service Trench,” on Page 3-12.
- Table 3-1, “Minimum Separation and Clearance Requirements for Service Trenches,” on Page 3-13.

Applicants should contact their local PG&E project coordinator in the development stages of their projects for additional details and requirements about using joint trenches.

3.3.5. Installing Offsets

In situations where more than two 90° bends are needed, applicants should consult their local PG&E project coordinators to determine whether additional raceway pull-boxes will be required to avoid excessive pulling tension on the service cables.

- A. PG&E does **not** approve short-radius conduit fittings, commonly known as LBs or service elbows, for use in underground service conduits that are intended to hold PG&E service conductors. Applicants must ensure that offsets are **not** installed in the following situations.
 1. Do not make an offset in the service lateral conduit entering the electric service panel or enclosure.
 2. Avoid making an offset in the conduit system because it may prohibit the use of a mandrel to prove the acceptability of the conduit system.
 3. Avoid making an offset in the service conduit because it will increase the pull tension required to install the service conductors.
- B. In some situations, applicants may be required to perform both of the following numbered actions.
 1. Install larger conduits and/or additional splice boxes or pull boxes to accommodate the installation of the conductors.
 2. Transition to cables appropriately sized for the service capacity.

C. The following scenarios represent situations where B.1. and B.2., on Page 3-9, could be required.

1. Construction sites where PG&E determines that larger-than-standard cables or conductors are required to maintain voltage and flicker drop.
2. Construction sites where normal pulling tensions may be exceeded.

NOTE: Applicants must be aware that pin adaptors, cable ringing, or splicing on additional cable **will not be used** to terminate cables. PG&E **does not** accept these termination techniques.

3.3.6. Selecting Backfill

Applicants must use backfill (i.e., sand or native soil) to provide a smooth bedding area when installing utility facilities. The backfill must fill all of the voids around the facilities and provide at least 12 inches of cover for the conduit or pipe. PG&E considers soil that contains occasional, rounded rocks that are 1/2 inch in diameter or less to be acceptable backfill.

Crushed rock or sharp-edged materials of any kind, or backfill containing easily breakable dirt clods larger than 6 inches in diameter, are not acceptable.

Additionally, PG&E **prohibits** applicants to use backfill with rocks greater than 3 inches in any dimension within 6 inches of the top of the pipe or conduit or less than 12 inches below the pavement subgrade.

In sections where a shallow trench is needed and allowed, place a cement-slurry cap above the conduit. The cap must be a minimum of 3 inches thick and made from a cement-slurry mix. The mix must consist of two parts sand to one part cement, with red die mixed in. The cap must rest on rock-free sand and not the conduit. Position the cap at least 6 inches above the conduit. The top of the cap must be a minimum of 8 inches below grade level. The width of the cap must be the same width as the trench.

When backfilling trenches on slopes or grades, bags of concrete and red die may be required on top of the conduit to prevent the backfill from moving down the slope or running out of the trench.

Soil compaction must be 95% and meet PG&E's and any applicable Federal, State, County and local requirements. A copy of the test results may be required by PG&E.

All of these requirements are at the discretion of the PG&E inspector. See [Exhibit B, *Joint Trench Configurations & Occupancy Guide*](#), located in [Appendix B](#). This guide contains additional backfill and trenching requirements. For PG&E-approved import material, see [Appendix B](#), for the Engineering Material Specification Number [EMS-4123](#), "Backfill Sand."

3.3.7. Providing Drainage From the Conduit System

In some conditions, water can enter into the wire and conduit system and migrate into the meter panel and/or building. The applicant or applicant's contractor must provide a means to discharge any excess water or water pressure from the conduit system.

The most common method required for discharging water from the conduit is installing a box outside near the base of the riser to the meter panel. Alternate locations may be required by the PG&E inspector or PG&E project coordinator. Any other methods of discharging water will require PG&E's approval **before** construction begins. For indoor electric meter rooms below grade or at grade level, additional methods of water drainage should be incorporated into the design of the meter room(s) to prevent the accumulation of water.

3.3.8. Installing Joint Utility Service Trenches

When installing electric services underground, the PG&E gas service pipe and the electric service lateral typically are installed in a common, joint trench. A joint trench also may include telephone and cable television facilities.

The following wet facilities are **not** permitted in a joint trench.

- Propane lines
- Sewer pipes
- Sanitary drains
- Storm drains
- Other wet-utility piping or facilities

There are additional requirements for separating a wet utility from a joint trench along with the electric and gas meters and service risers.

Applicants must submit a written request to PG&E when they want to include other facilities in a joint trench. The request must include a justification and be submitted to PG&E for review and approval **before** excavation or work begins.

PG&E must coordinate joint trench installations with telephone, cable television, or other facilities. This coordination requires lead time, so applicants should submit their requests and justifications as early in the planning process as possible. Applicants must ensure that PG&E has reviewed and approved their trenching plans before digging begins.

Figure 3-4, on Page 3-12, illustrates a "Typical Joint Service Trench." Separation and clearance details for the trenches are found in Table 3-1 on Page 3-13. Also, see [PG&E Standard S5453, Exhibit B, Joint Trench Configurations & Occupancy Guide](#), located in [Appendix B](#) of this manual. This guide contains additional information and joint trench requirements. For PG&E-approved import material, see [Appendix B](#) for Engineering Material Specification Number [EMS-4123](#).

When applicants plan to use joint service trenches, they must ensure that the gas and electric meters are installed either adjacent to, or in close proximity to, each other. [Section 5](#), "Electric Metering: General;" [Section 6](#), "Electric Metering: Residential;" and [Section 7](#), "Electric Metering: Commercial, Industrial, and Agricultural" provide information about determining acceptable locations for utility electric meters. [Section 2](#), "Gas Service," Subsection 2.4.2., "Gas Meter-Set Locations," on Page 2-20, provides information about determining acceptable locations for utility gas meters.

Applicants must discuss the service arrangements and coordinate the meter locations and joint trench requirements with a PG&E project coordinator **before** installing utility conduits or gas service piping.

Applicants must ensure that when multiple service facilities (i.e., gas, electric, and telecommunications) are installed in close proximity (e.g., in a joint trench), a 12-inch minimum, radial separation is maintained where those facilities transition from below ground to above ground. PG&E allows an exception to that rule when the separation is between PG&E secondary, electric-service conduit and gas-service piping. In this instance, the minimum separation distance may be reduced to 6 inches. Clearances between other facilities can be reduced **only** when the facility owners reach a mutual agreement.

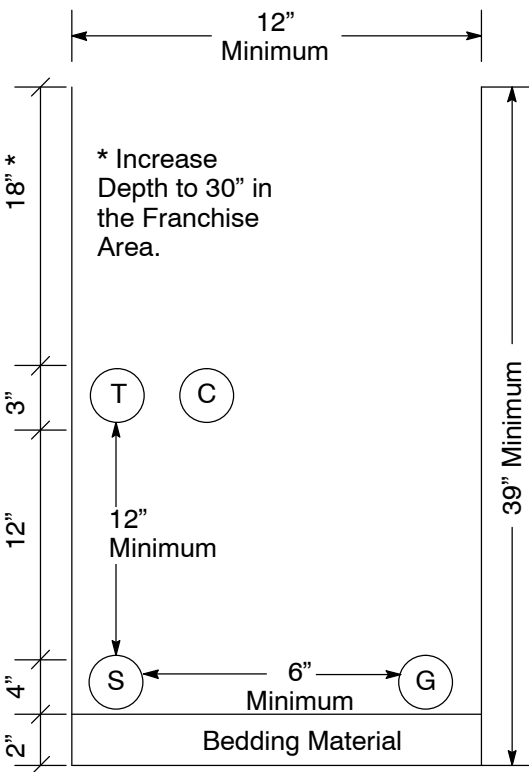

Figure 3-4
Typical Joint Service Trench

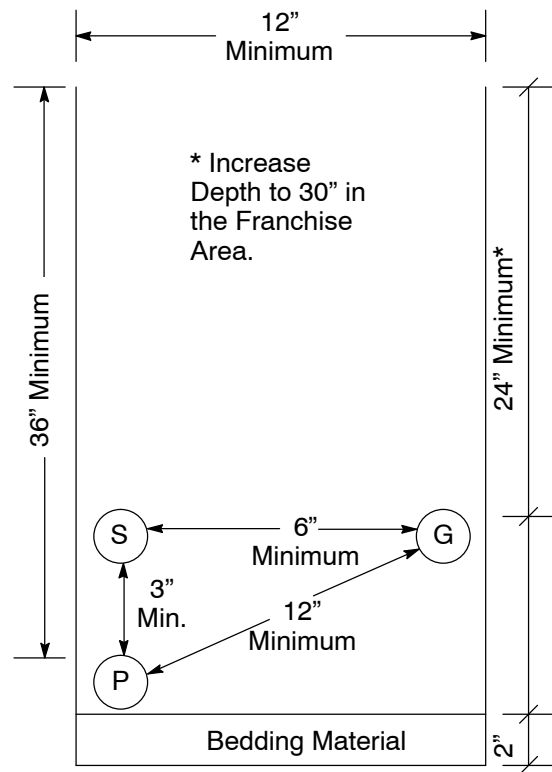

Figure 3-5
PG&E Electric and Gas Service Trench

Notes in reference to Figure 3-4 and Figure 3-5.

1. Trench depth will vary depending on conduit size.
2. Soil compaction must meet PG&E's and any applicable federal, state, county, and local requirements.
3. All separation and clearance dimensions must be met in Table 3-1 on Page 3-13.
4. For more information on Figure 3-4, see PG&E's [Joint Trench Configurations & Occupancy Guide](#), located in [Appendix B](#).

Table 3-1 Minimum Separation and Clearance Requirements for Trenches¹

		G	Duct T	DB T	C	S	P	SL
G	Gas ²	-	12	12	12	6	12	6
T	Telephone (Duct)	12	-	1	1	12	12	12
T	Telephone (Direct Bury)	12	1	-	1	12	12	12
C	CATV	12	1	1	-	12	12	12
S	Electric Secondary	6	12	12	12	1.5	3	1.5
P	Electric Primary	12	12	12	12	3	3	3
SL	Streetlight ³	6	12	12	12	1.5	3	1.5
NE	Foreign Electric Sourced (Non-PG&E) ⁴	12	12	12	12	12	12	12

¹ All separation clearance distances are in inches.

² For more information about this table, see PG&E Bulletin [TD-5453B-002](#), "Updated Separation Requirements For Conduit in Joint Trench, in [Appendix B](#) of this manual.

³ Streetlight circuits **not owned** by PG&E must be installed to meet the requirements in PG&E's [Joint Trench Configurations & Occupancy Guide](#). Specifically, applicants must review the requirements for working with a second utility company.

⁴ Must be considered a "utility" as defined in [PG&E Standard S5453](#).

Applicants must ensure that adequate amounts of space exist to maintain and operate the facilities. Applicants must ensure that the area immediately **behind** the gas meter, service facilities, and risers and **between** those facilities and the premises or structures being served is kept free and clear of all other facilities or equipment such as pipes, wires, cables, or conduits. See [Section 2](#), Figure 2-19, "Electric and Gas Meter Set Separation Dimensions and Clearances," on Page 2-32.

NOTE: Applicants should consider installing conduit one size larger than the required minimum in case larger cable is required or needed for future upgrades. Refer to Subsection 1.14., "Determining the Service Rating," on Page 1-12, for a description of the methods PG&E uses to determine the ampacity (capacity) rating of customer equipment.

3.3.9. Providing a Service-Termination Facility

In addition to the requirements in Table 3-1, above, applicants must provide and maintain a satisfactory termination facility on or within the building or structure to be served.

PG&E will **not** install services supplied from different electrical sources in the same termination facility unless the services are separated using suitable barriers. When two or more services are in one termination facility, the minimum dimensions of each compartment created by the barriers must be the same as if each compartment were a separate termination facility.

NOTE: See new service and current transformer (CT) installation requirements in Section 5, "Electric Metering: General," Subsection 5.2.4., "Requirements for Installing Secondary Terminations (0–600 Volt) in Metering Equipment Requiring CTs," on Page 5-4.

3.3.10. Bioswales and Large Wet Locations

A bioswale is a long, channeled depression or trench that receives rainwater runoff and uses vegetation and organic matter to slow water infiltration and filter-out pollutants. A bioswale is considered a wet location and applicants must **not** install PG&E facilities that go through or close to a bioswale. Bioswale areas should be avoided and PG&E facilities should be designed to go around them. If applicants cannot avoid a bioswale area, they must apply additionally protective methods when designing PG&E facilities. Also see [Numbered Document 038193](#), “Minimum Requirements for the Design and Installation of Conduit and Insulated Cable,” located in [Appendix C](#).

3.4. Electric Underground Documents

Table 3-2 below lists “Electric Underground Numbered Documents” that are provided at the back of this manual in [Appendix C](#). Also, [Appendix C](#) provides electric underground documents that are not listed in the table below. See PG&E’s Internet website at www.pge.com/greenbook to access the most recent versions of these documents **or** contact your local PG&E project coordinator. Most of these documents also are available in PG&E’s *Electric Underground Construction Manual, Volume 1*.

Table 3-2 Electric Underground Numbered Documents

Section ¹	Document Number	Title
Connectors	013109	Corrosion Resistant Ground Rods and Ground Rod Clamps
Enclosures	028028	Secondary Electric Underground Enclosures
Services	036670	Temporary Underground Electric Service Single-Phase, 120/240 Volt, 200 Amps Maximum
Transformers	045292	Concrete Pad for Three-Phase, Loop-Style, Pad-Mounted Transformers
General	051122	Clearances and Location Requirements for Enclosures, Pads, and Underground Equipment
Services	058817	Terminating Underground Electric Services 0–600 Volts in Customer-Owned Facilities
Transformers ²	063422	Landscape Screen for Pad-Mounted Transformers
Services	063927	Methods and Requirements for Installing Residential Underground Electric Services 0–600 V to Customer-Owned Facilities
Services	063928	Methods and Requirements for Installing Commercial Underground Electric Services 0–600 Volts to Customer-Owned Facilities
Services	063929	Requirements for Bus Duct Entrance Termination Unit for Use With Pad-Mounted Transformers
Transformers	064309	Box-Pad for Pad-Mounted Transformers
General ²	066211	PG&E Approved Electric Distribution Materials Manufacturers

¹ For PG&E reference only: “Section” refers to the sections in PG&E’s [Electric Underground Construction Manual, Volume 1](#), which contains these documents.

² This document is not in the [Electric Underground Construction Manual](#).

3.4.1. Mandrels

The following section includes both an overview of, and a procedure for using, PG&E-approved, flexible-steel mandrels to prove conduit systems.

A. Using Mandrels to Prove Conduit Systems

Applicants must ensure that the conduit systems required for PG&E cables and/or conductors are installed in a trench that meets all of PG&E's requirements and specifications for the particular job or project. The conduit systems must meet PG&E's requirements for each specific installation, as well.

NOTE: The term "conduit system" includes conduits, conduit bends, conduit fittings, and all related components (e.g., bell ends and cable protectors) that are needed to install PG&E cables and conductors.

Applicants must ensure that conduit systems are **not** covered or hidden from view before the facilities are inspected visually by a PG&E field inspector. The inspector must determine if the conduit system and its installation comply with all of PG&E's specifications (e.g., type, size, schedule, radius of bends) and installation requirements before the customer backfills the trench.

After the conduit system passes PG&E's visual inspection, including visual verification of the conduit system's materials and the radius of the bends, the applicant must backfill the trench and compact the soil. Then, the applicant must provide PG&E with proof that the conduit system is in compliance by successfully inserting and pulling an approved, flexible-steel mandrel through the **entire** conduit system.

The PG&E inspector remains onsite to ensure that the appropriately sized and approved, flexible-steel mandrel is inserted and pulled through the length of the conduit system without encountering blockages or obstructions.

The applicant must provide the mandrel and appropriate pulling tape, as well as follow the procedures in Subsection B, below, for using the mandrel.

B. Procedure for Using Mandrels

Applicants must follow the procedural steps below when using a mandrel to prove a conduit system.

Step 1. Select the mandrel that is sized properly for the type of conduit that will be proven. See Figure 3-6, "Flexible Steel Mandrel," on Page 3-17, and Table 3-3, "Mandrel Dimensions, Part Numbers, and Order Codes," on Page 3-17, for mandrel specifications.

NOTE: For high-density polyethylene (HDPE) continuous conduit only (i.e., 3 inch, 4 inch, 5 inch, and 6 inch sizes), use the next smaller-size mandrel shown in Table 3-3 on Page 3-17.

- Step 2.** To pull the mandrel through the conduit, securely tie one end of the 2,500-pound pulling tape to the pulling eye of the mandrel. (The pulling tape was installed in the conduit previously.)
- Step 3.** Securely tie a second section of 2,500-pound pulling tape to the pulling eye located on the other end of the mandrel. This section of tape must be long enough to replace the pre-installed pulling tape completely.
- Step 3. ensures that a run of pulling tape remains in the conduit after the mandrelling process is completed. Also, if the mandrel becomes blocked or stuck in the conduit, the second run of pulling tape allows the mandrel to be pulled back out of conduit **and** provides a means of measuring the distance to the point of blockage.
- Step 4.** After both pulling tapes are attached securely to the mandrel, insert the mandrel into one end of the conduit. Slowly start to pull the pulling tape at the opposite end of the conduit. This removes any slack in the pulling tape.
- Step 5.** Slowly pull the mandrel through the conduit by hand or non-mechanically. The rate of the pull should not exceed 100 feet per minute. Both the person pulling the tape and the PG&E inspector must check the pulling tape for signs of stress (i.e., molten plastic) as the tape comes out of the conduit.

NOTE: The PG&E inspector may **not** approve a section of the conduit if any portion of the pulling tape shows damage in the form of molten plastic. If the inspector decides to reject the conduit section, he or she will secure the melted section of pulling tape as evidence.

If the mandrel passes through the conduit without encountering any blockage or obstructions, the PG&E inspector approves the conduit section for use.

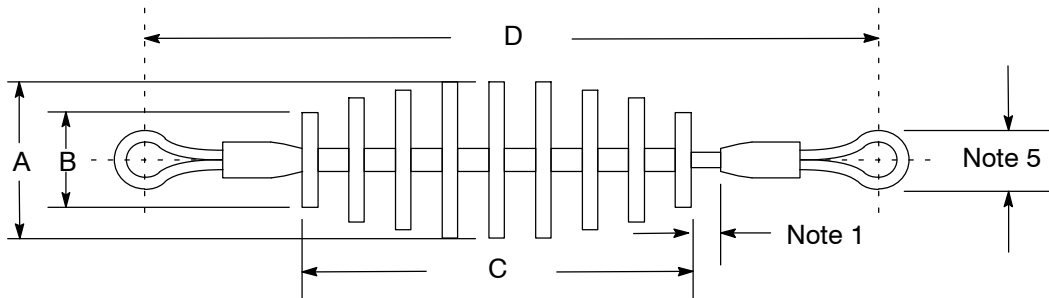

**Figure 3-6
Flexible Steel Mandrel**

Notes in reference to Figure 3-6.

1. The length must be adequate for the mandrel to pass through a 24-inch radius bend (all sizes).
2. The disks must be fabricated from 1/2-inch, flat, steel plate (average weight: 490 pounds per cubic foot) with a 7/16-inch hole for the 3/8-inch cable.
3. The spacers must be fabricated from 1/2-inch iron pipe size (IPS) pipe with a minimum inside diameter of 0.6 inches.
4. Cable size: 3/8-inch, 6 x 19 mild, plow-steel hoisting rope.
5. The outside diameter of the eye must not exceed Dimension A.
6. The size must be stamped permanently into one end of the plates.

Table 3-3 Mandrel Dimensions, Part Numbers, and Order Codes¹

Size (In Inches)	PG&E Code	Manufacturer Part Numbers ³	Dimensions (In Inches)				
			A	B	C	D ²	Spacer Length
2	202567	08400-200	1.69	1.69	6.5	15	0.25
3	202570	08400-300	2.65	1.65	10.5	23	0.75
4	202571	08400-400	3.57	2.57			
5	200911	08400-500	4.56	3.56			
6	202572	08400-600	5.51	4.51			

¹ For HDPE continuous conduit only (sizes 3 inches, 4 inches, 5 inches, and 6 inches), use the next-smaller-size mandrel.

² "D" dimensions are approximate.

³ PG&E's approved mandrel manufacturers, DCD Design & Manufacturing.

Table 3-4 Businesses That Sell or Rent Mandrels¹

Company	Street Address	City	Zip	Phone Number
Utility Division Locations (UDL)	5275 Central Ave.	Fremont	94536	(510) 656-9680
WESCO	1544 N. Maple Ave.	Fresno	93703	(559) 255-4423
WESCO/Herning	4925 E. Annadale Ave.	Fresno	93725	(559) 443-5600
WESCO/Herning	567 Exchange Ct.	Livermore	94550	(925) 449-2550
Pacific Utilities Supply Co.	2475 Estand Way	Pleasant Hill	94523	(925) 674-1600
WESCO	1045 W. National Dr. Suite 19	Sacramento	95834	(916) 928-1001
Independent Electric Supply (IES)	1370 Bayport Ave.	San Carlos	94070	(650) 594-9440
WESCO	2800 Mead Ave.	Santa Clara	95051	(408) 562-0400
Independent Electric Supply (IES)	2801 Research Park Dr.	Soquel	95073	(831) 464-3232
Utility Division Locations (UDL)	200 East Larch Rd.	Tracy	95304	(209) 832-2038
Utility Division Locations (UDL)	4076 Channel Dr.	West Sacramento	95691	(916) 376-8400

¹ Mandrels must be from the approved manufacturer listed in Table 3-3 on Page 3-17.

**SECTION 4
ELECTRIC SERVICE:
OVERHEAD**

SECTION 4 ELECTRIC SERVICE: OVERHEAD

Section 4 Electric Service: Overhead

4.1. Scope

This section of the manual provides instructions and minimum clearance requirements for attaching permanent, overhead services to residential and nonresidential properties. The term “residential” includes mobile homes installed on foundations in locations other than mobile home parks.

NOTE: Requirements for installing and attaching PG&E overhead services may be different than local city or county ordinances, as well as national or California electric codes. Contact your local PG&E project coordinator if you have questions. See [Table FM-1, “Service Planning Office Contact Information.”](#) at the front of this manual starting on Page iv, for specific contact numbers listed by area.

4.2. General

Pacific Gas and Electric Company (PG&E) will **not** supply new overhead services to applicants when either of the following conditions exist:

- A. When buildings or premises are located in areas designated either by local jurisdictions or by PG&E as underground districts.
- B. When buildings or premises are located in areas zoned for commercial or residential use and the installed service equipment and/or load requires PG&E to use a 75-kilovolt ampere (kVA) or larger transformer.

4.2.1. Safety Reminder



CAUTION

Flame resistant (FR) clothing is required while working on, working near, or observing others working on any PG&E facility.

4.3. Locating Overhead Services

4.3.1. Point of Attachment

In areas served from overhead lines, PG&E will install an overhead service drop from the Company’s distribution line to a point of attachment on the applicant’s residence, building, or structure. PG&E follows the guidelines listed below to ensure the service is installed safely and efficiently.

- A. The point of attachment must be located so it can be reached with a single span from PG&E’s facilities.
- B. The span should **not** cross over adjacent property, if possible.
- C. The span must maintain the required, vertical, clearance-to-ground.

The point of attachment may be either on the building wall near the PG&E line or on a periscope fixed to the building's roof, usually not more than 18 inches in back of that wall. Figure 4-1, "Preferred and Alternate Locations for the Overhead Service Drop Attachment," below, provides more information about the point of attachment.

Applicants must consult PG&E **before** installing the building's wiring. PG&E must approve of the location selected for the utility service attachment.

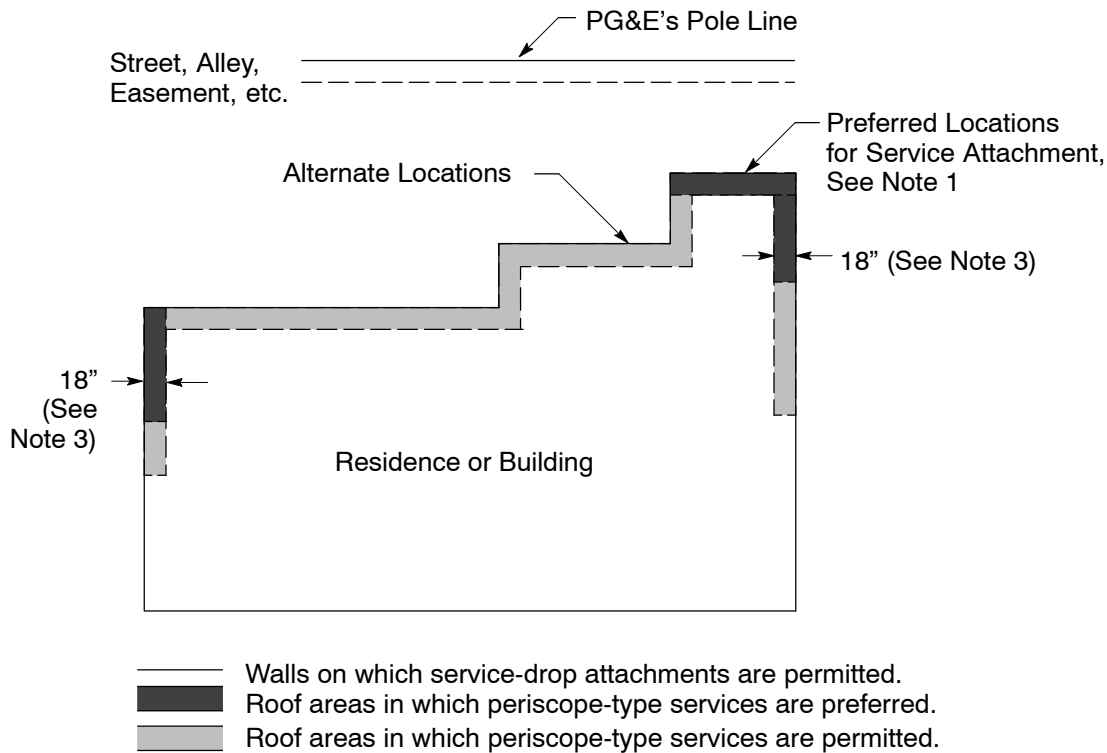

Figure 4-1
Preferred and Alternate Locations for the Overhead Service Drop Attachment (see Note 2)

Notes in reference to Figure 4-1.

1. Applicants may attach service drops to sidewalls. Applicants must ensure that the service-drop conductors do **not** exceed 75 feet and do **not** cross over either the buildings being served or the adjacent property. Finally, applicants must ensure that the required conductor clearances and accesses to the electric meters are maintained.
2. For more information on meter location requirements, see [Section 5](#), "Electric Metering: General;" [Section 6](#), "Electric Metering: Residential;" and [Section 7](#), "Electric Metering: Commercial, Industrial, and Agricultural" (as applicable). For available short-circuit current information and requirements, see Subsection 5.7.2., "Main Service Disconnect Switch Rated for Amperes Interrupting Capacity (AIC)," found on Page 5-23.
3. The **required** maximum setback affects nonresidential customers only. The preferred maximum setback is for residential installations, but is not required.

4.3.2. Two or More Buildings on One Lot

If more than two dwellings or buildings are located on the same lot, applicants must consult PG&E to determine acceptable service attachments and meter locations **before** wiring the buildings.

Typically, PG&E installs only one service lateral to a single building on one premise, or to one enterprise (with either one building or multiple buildings) on a single premise. However, PG&E may provide more than one service lateral under the following circumstances.

- Where it is allowed or required by PG&E’s tariff schedules.
- For PG&E’s convenience.
- Where it is required by ordinance.
- When it is installed as a special facility.

4.4. Service Drop Clearances

NOTE: See [Table FM-1, “Service Planning Office Contact Information,”](#) starting on Page iv, for specific contact numbers listed by area.

Applicants can request a PG&E project coordinator to specify a location for service drop attachments. When PG&E selects the location, applicants are assured that the service conductors will maintain the required clearances above thoroughfares and structures, as well as the required clearances away from windows, doors, and building exits.

The minimum clearances from the ground, structures, and other objects for overhead service drops are specified in the California Public Utilities Commission’s (CPUC’s) [General Order \(G.O.\) 95](#), “Rules for Overhead Electric Line Construction.” Figure 4-2 through Figure 4-20 list and illustrate these minimum clearances.

Applicants must ensure that the elevation at the point of attachment is high enough to maintain all of the required vertical clearances. Applicants should allow for normal conductor sag when determining these vertical clearances.

[G.O. 95](#) allows the vertical clearance restrictions for service drops to be reduced in certain instances. PG&E’s review and approval is required before any reductions in vertical clearances are allowed. **Applicants should contact PG&E as soon as possible in the planning phases of their projects to ensure that any potential problems or exceptions are addressed before construction begins.**

Requirements for installing and attaching PG&E overhead services may be different than local electrical codes.

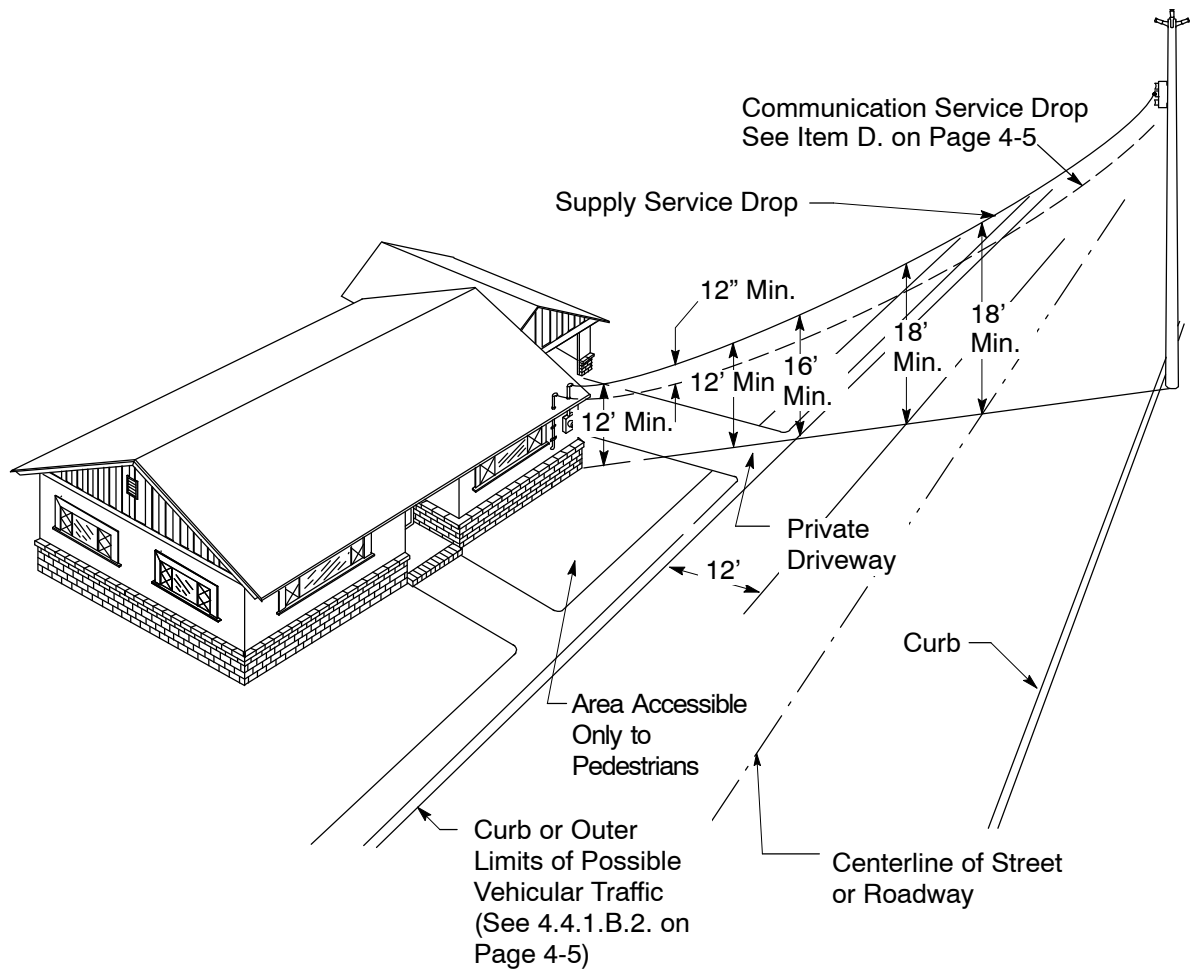

Figure 4-2
Ground Clearances for Supply Service Drops, 0 Volts Through 750 Volts, Residential Installations
(Required by the CPUC)

4.4.1. Vertical Clearance for Residential, Overhead Service

A. Clearance Above Rails

Applicants must ensure that the following clearances are maintained when requesting electric service be placed over train or trolley tracks.

1. Crossing above railroad tracks **without** overhead trolley wire: 25 feet
2. Crossing above railroad tracks **with** overhead trolley wire:
 - Above rails where freight cars are transported: 26 feet
 - Above rails where freight cars are not transported: 23 feet

B. Clearance Above Thoroughfares in Public Areas and in Private Communities of 10 or More Residences

Applicants must ensure that the following clearances are maintained when requesting electric service be placed above thoroughfares in public and private communities with more than 10 residences.

1. Crossing above the center portion between points 12 feet horizontal from curbs: 18 feet
2. Crossing at the curb line (from the level of the street, not the sidewalk): 16 feet
3. Crossing where there are no curbs: applicants must consider the curb line as the outer limit of possible vehicular traffic: 16 feet

C. Clearance Over Residential Property

Applicants must ensure that the following clearances are maintained when requesting electric service be placed over residential property.

1. Crossing over private roads and other areas accessible to agricultural equipment: 15 feet
2. Crossing over agricultural equipment: maintain 16 feet, if possible
3. Crossing over private driveways or other areas accessible to vehicles: 12 feet
4. Crossing over areas accessible to pedestrians only: 12 feet.

D. Clearance From Communication Service Drops

Applicants must ensure that the following clearances are maintained when requesting electric service be placed over communication service drops.

1. Normal radial clearance: a minimum of 24 inches.
2. Within 15 feet of the point of attachment on a building or structure: the normal radial clearance may be reduced to a minimum of 12 inches.

E. Clearance From Swimming Pools

Avoid installing utility service drops above public and private swimming pools, when practical.

The CPUC, not local agencies or codes, regulates, by its adoption of [G.O. 95](#), the installation and clearances of utility-owned, operated, and maintained supply lines and service drops. [G.O. 95](#) contains specific requirements for installing and maintaining utility supply-line and service-drop clearances above swimming pools. Figure 4-3, “Minimum Clearance for All Drops Above or Adjacent To Swimming Pools,” on Page 4-6, illustrates the minimum-permitted clearances mandated by [G.O. 95](#) where utility service drops are installed above swimming pools.

NOTE: Table 4-1, “Minimum Clearances Over Swimming Pools,” on Page 4-6, also provides clearance information for drops above or adjacent to swimming pools.

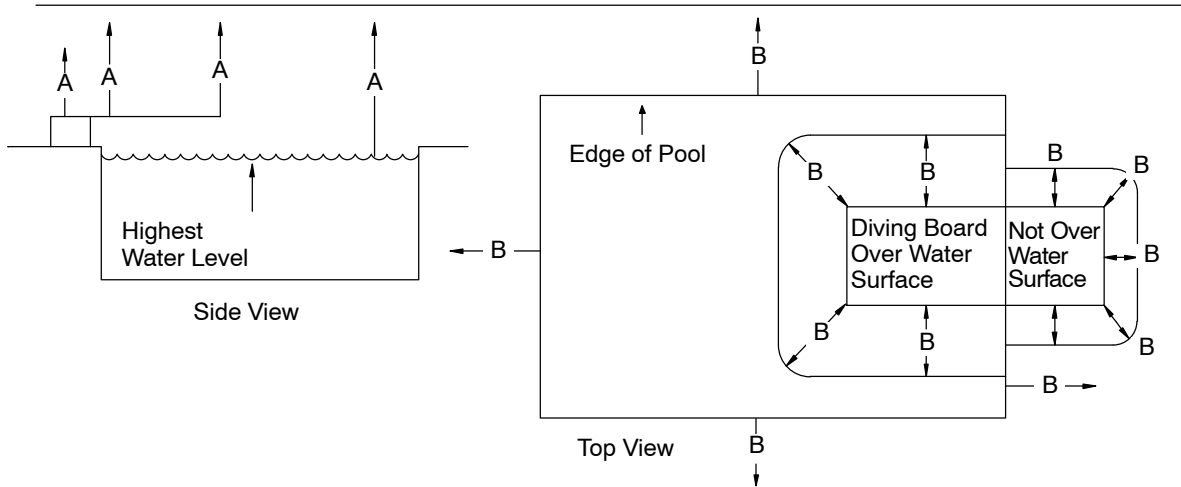

Figure 4-3
Minimum Clearance for All Drops Above or Adjacent To Swimming Pools

Table 4-1 Minimum Clearances Over Swimming Pools¹

Minimum Vertical and Radial Clearances	A	B
	Vertical	Radial
	(In Feet)	
Unprotected Line Conductors-Vertical Over the Highest Water Level and Radial From the Top Edge of the Pool Walls:		
1. 0 through 750 volts	20	20
2. Above 750 volts through 22,500 volts	25	25
3. Above 22,500 volts through 300 kilovolts (kV)	30	30
Service Drops-Vertical Over the Highest Water Level and Radial From the Top Edge of the Pool Walls:		
4. Pools: public and commercial	16	16
5. Pools: residential	12	12
Service Drops (Over Diving Boards or Platforms):		
6. Portion of the board or platform that is over the water's surface	16	8
7. Portion of the board or platform that is not over the water's surface	12	3
Guys-Ungrounded Portions:		
8. Over the highest water level and from the top edge of the pool walls	18	18
9. Over the diving board or platform (the portion that is over the water's surface)	18	8
10. Over the diving board or platform (the portion that is not over the water's surface)	12	6
Guys-Grounded Portions:		
11. Over the highest water level	16	—
12. Over the diving board or platform (the portion that is over the water's surface)	16	8
13. Over the diving board or platform (the portion that is not over the water's surface)	8	3

¹ Clearance requirements may be different than local electrical codes.

4.4.2. Clearance Above Buildings

Table 4-2, “Minimum Allowable Clearance of Service Drops From Buildings – 0 Volts Through 750 Volts,” below, lists the required clearances for buildings that are receiving electric service.

Table 4-2 Minimum Allowable Clearance of Insulated Service Drops From Buildings – 0 Volts Through 750 Volts

	Minimum Clearance From Buildings
	Insulated Conductors (See Note 1) 0 Volts Through 750 Volts
Vertical Clearances Above:	
1. All portions of buildings including metallic or nonmetallic cornices, decorative appendages, eaves, roofs, or parapet walls of the building being served.	See Notes 2, 3, and 4
2. Metallic or nonmetallic, “nonwalkable” overhang, patio cover, or other structure.	See Notes 2 and 3
3. Other buildings on the same premises.	2 Feet
4. Buildings on other premises.	8 Feet (See Note 5)
Horizontal and Radial Clearances:	
1. From fire escapes, exits, windows, and doors.	3 Feet

¹ Weather-resistant, covered conductors are **not** used in new installations. See [G.O. 95 Rule 54.8](#), “Service Drops, 0–750 Volts,” Table 10, “Minimum Allowable Clearance of Service Drops 0–750 Volts from Buildings,” on Page V-72, for insulated conductor clearances.

² Not less than 1/2 inch for residential services. Not less than 12 inches for nonresidential services as shown in Figure 4-13 through Figure 4-20 on Page 4-13.

³ An applicant must ensure that the service drop’s point of attachment for industrial and commercial premises is no more than 18 inches. Take this measurement from **behind** the front face of the building wall facing the pole line from which the service drop originates.

⁴ Clearance requirements may be different than local electrical codes.

⁵ Reduce to 2 feet for nonmetallic roofs when the roof slope exceeds 9 inches of rise per 12 inches of run. (See Figure 4-4, “Nonmetallic Roof,” below.)

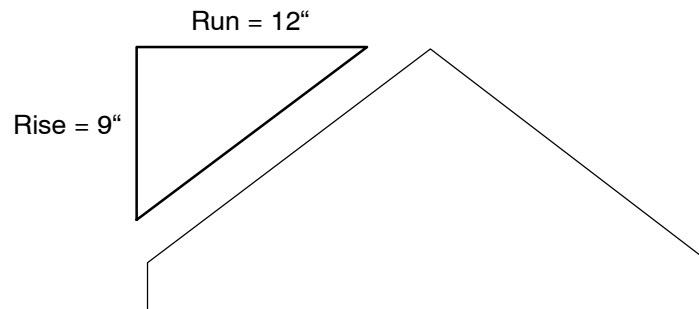

**Figure 4-4
Nonmetallic Roof**

4.4.3. Clearance at the Residential Point of Attachment

PG&E recommends that applicants do **not** locate electric supply and communication services in the same vertical plane. Figure 4-11, one of the “Clearance at the Residential Point of Attachment” illustrations, found on Page 4-9, shows the recommended arrangement for the communication service drop.

Typically, the service drop is attached **below** the level of the service weatherhead; however, it may be attached **above** the service weatherhead, as shown in Figure 4-7 and Figure 4-9, **both** located on Page 4-9, if the two following situations exist.

- A. It is impractical to attach the service drop below the level of the service weatherhead.
- B. The service-drop conductor’s attachment point is located 24 inches or less from the service weatherhead.

Applicants must ensure that the line length of the open wiring (i.e., drip loop) between the point of service attachment and service weatherhead does **not** exceed 3 feet.

Applicants must ensure that the clearance requirements for the PG&E overhead service are met. These clearances may be greater than local electrical codes.

PG&E will **not** attach services to periscope structures made of plastic.

Figure 4-5 through Figure 4-11, all representing “Clearance at the Residential Point of Attachment,” provide examples of clearances for overhead service-drop installations and terminations. These seven figures are located on Page 4-9.

NOTE: For overhead, temporary services, refer to [Numbered Document 025055](#), “Requirements For Customer-Owned Poles,” in [Appendix C](#), “Electric and Gas Engineering Documents.”

NOTE: Refer to [PG&E Bulletin TD-2999B-030](#), “Technical Requirements for Electric Service Interconnection at Primary Distribution Voltages,” in [Appendix B](#), “Electric and Gas Service Documents,” for technical information on primary services.

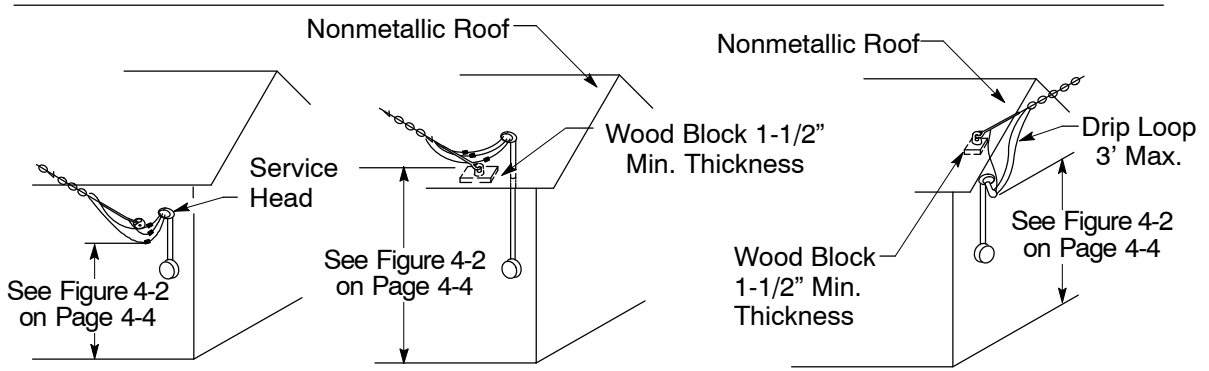

Figure 4-5

Figure 4-6

Figure 4-7

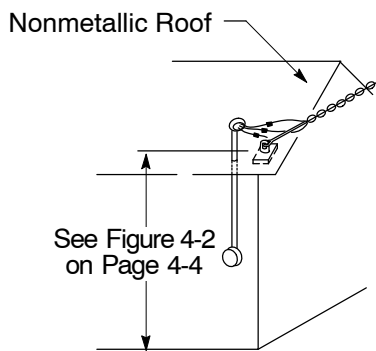

Figure 4-8

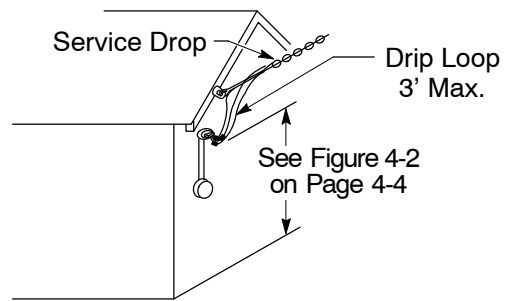

Figure 4-9

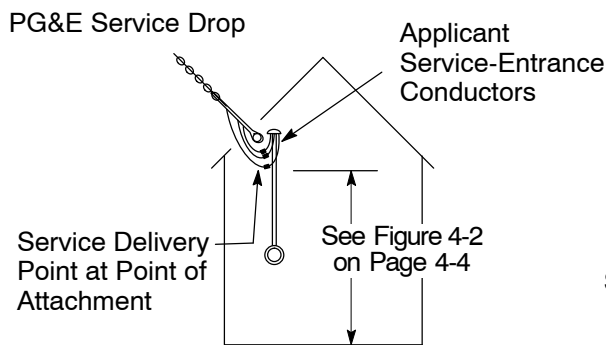

Figure 4-10

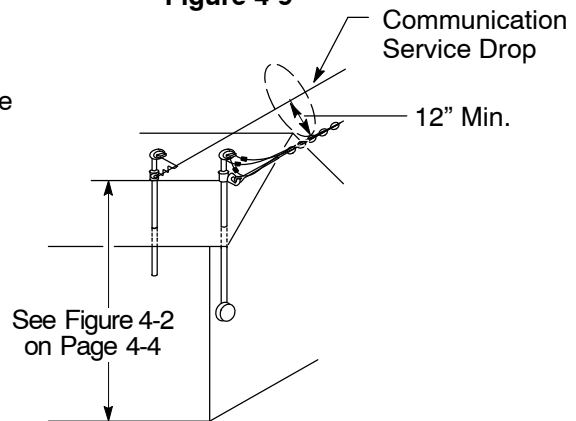

Figure 4-11

Clearance at the Residential Point of Attachment

4.4.4. Vertical Clearance on Nonresidential Property

Table 4-3, “Vertical Clearance From the Ground on Nonresidential Property,” located below, provides the minimum vertical distance (in feet) from the ground on nonresidential property.

Applicants must ensure that periscope attachment structures are constructed with one of the following, approved materials.

- 1-1/4-inch minimum, galvanized rigid steel (GRS) or intermediate metal conduit (IMC) rigid steel.
- 2-inch minimum rigid aluminum conduit measured in iron pipe size (IPS) dimensions.

PG&E will **not** attach a span to plastic periscope structures.

Periscope extensions projecting above the roof may require bracing against the pull of the service-drop conductors, as shown in Figure 4-39, “Unbraced Periscope Structure (Residential and Nonresidential),” found on Page 4-23.

Typically, the service drop is attached **below** the level of the service weatherhead; however, it may be attached **above** the service weatherhead if **both** of the following situations exist.

- It is impractical to attach the service drop below the level of the service weatherhead.
- The attachment point on the service-drop conductors is located less than 24 inches from the service weatherhead.

Ensure the length of the open-wire drip loop does **not** exceed 3 feet.

PG&E connects the Company’s service conductor and an applicant’s service-entrance conductor **below** the service weatherhead.

Table 4-3 Vertical Clearance From the Ground on Nonresidential Property¹

Description	Minimum Vertical Distance (In Feet)
Over private driveways, lanes, and other areas (e.g., alleys and parking lots) accessible to vehicles.	16
Over areas accessible to pedestrians only.	12
Over buildings and bridges, or over structures (attached or unattached) that do not ordinarily support conductors and on which people can walk.	8

¹ Clearance requirements may be different than local electrical codes.

A. Clearance From Communication Service Drops

Applicants must ensure that the following clearances are maintained when requesting electric service to be placed over communication service drops.

1. Normal radial clearance: a minimum of 24 inches.
2. Within 15 feet of the point of attachment on a building or structure: the normal radial clearances may be reduced to a minimum of 12 inches.

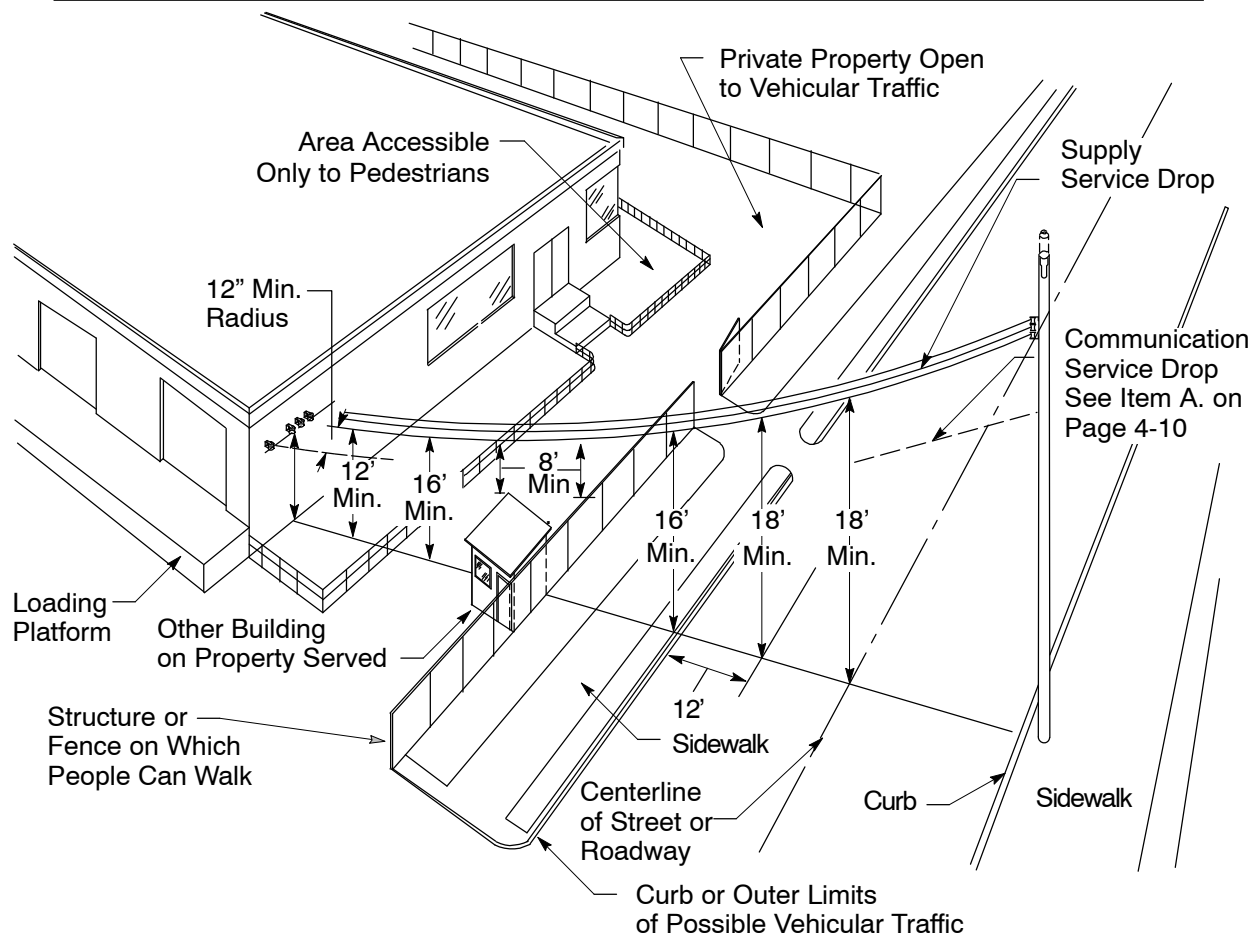

Figure 4-12
Ground Clearances for Supply Service Drops, 0 Volts Through 750 Volts,
Industrial and Commercial Installations (Required by the CPUC)

Figure 4-13 through Figure 4-20, all representing “Clearances for Nonresidential Buildings Using Insulated Conductors” and all located on Page 4-13, show overhead service drops and vertical-clearances, as measured from the ground, for commercial and industrial installations and large residential buildings.

4.4.5. Clearances for a Nonresidential Building Service Drop Using Cable or Equally Insulated, Open-Wire Service Conductors

Applicants can use the clearances shown in Figure 4-13 through Figure 4-20 only when they use Type N-SD service-drop cable, or equally insulated cable, open-wire service conductors. Applicants must **not** use weatherproof-rated conductors.

Figure 4-12, “Ground Clearances for Supply Service Drops, 0 Volts Through 750 Volts, Industrial and Commercial Installations (Required by the CPUC),” located above, provides the required clearances from a service drop to the ground.

Figure 4-21, “Clearance Around Windows,” and Figure 4-22, “Clearance Around Doors,” both located on Page 4-14, provide applicants with the required clearances from fire escapes, exits, windows, doors, and other locations where people could be present.

Applicants must use a 1-1/4-inch minimum GRS or IMC rigid steel, or 2-inch minimum rigid aluminum conduit (IPS dimensions) for all periscope attachment structures. See Figure 4-13, Figure 4-14, Figure 4-15, Figure 4-19, and Figure 4-20, all representing “Clearances for Nonresidential Buildings Using Insulated Conductors,” found on Page 4-13, for examples.

The clearances shown in Figure 4-13 through Figure 4-20 only apply to insulated services, up to a 750-volt maximum, over nonmetallic roofs or decorative appendages. Applicants also should refer to the service-entrance, conductor-clearance requirements found in the *State Building Standards Electrical Code*.

The special 24-inch minimum clearance, illustrated in Figure 4-20, is applicable only to service-drop cable.

Either brace the periscope attachment structures as shown, or ensure that the structures are supported using similar, acceptable methods. For more information on bracing periscope attachment structures, see Figure 4-34 and Figure 4-35, both representing “Service to Nonresidential Premises,” and both found on Page 4-18. Also, see Figure 4-38, “Braced Periscope Attachment Structure,” found on Page 4-20, and Table 4-5, “Maximum Mast Height Above the Roof *Without* Bracing,” found on Page 4-22.

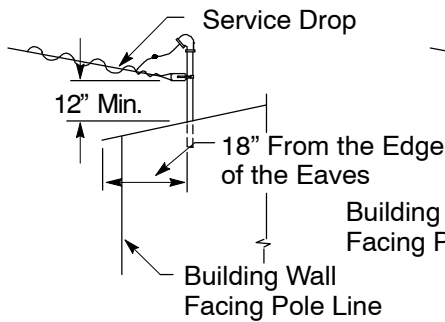

Figure 4-13

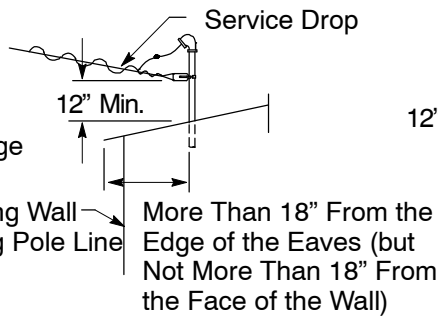

Figure 4-14

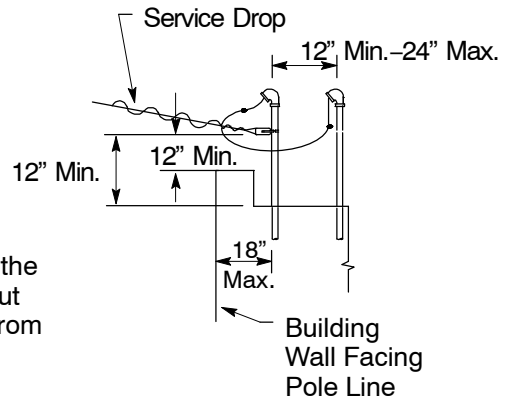

Figure 4-15

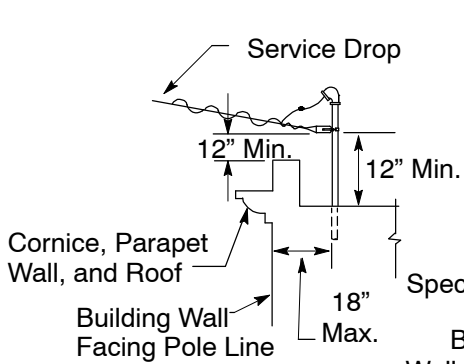

Figure 4-16

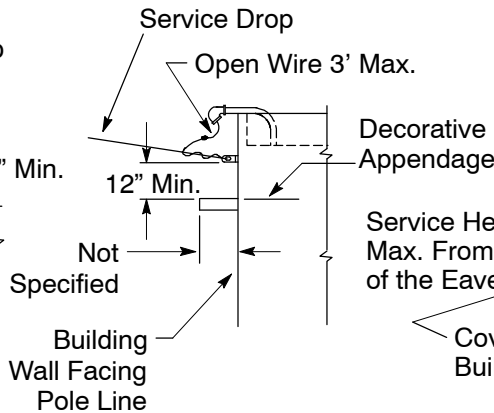

Figure 4-17

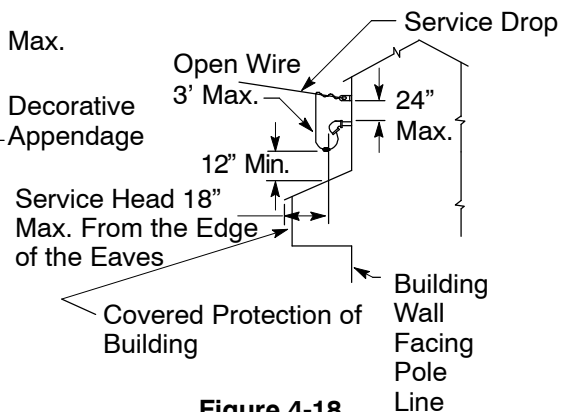

Figure 4-18

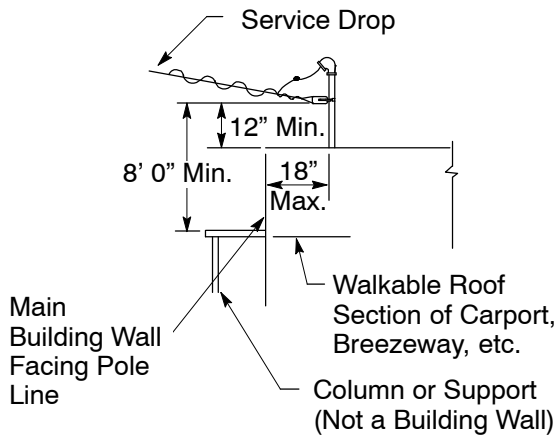

Figure 4-19

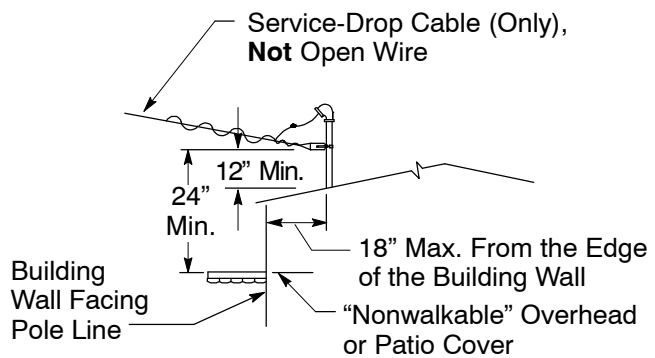

Figure 4-20

Clearances for Nonresidential Buildings Using Insulated Conductors (0 Volts–750 Volts)

4.4.6. Clearances Around Doors and Windows

Service drops are not required to clear **buildings** by any specified horizontal distance; however, applicants must ensure that the service weatherhead, the service drop, and the open wires between the service weatherhead and the service drop maintain the following clearances from fire escapes, balconies, stairways, exits, doors, windows, and other locations where people could be present.

- A. Wires that are either at or below the level of the top of exits, doors, windows, and other openings **must** have a radial clearance from the boundaries of such openings of not less than 3 feet, as shown in Figure 4-21 below.
- B. Wires less than 8 feet above, or 3 feet below, the surface levels of fire escapes, balconies, porches, stairways, and walkways **must** have a minimum horizontal clearance of at least 3 feet from such surfaces, as shown in Figure 4-22 below.

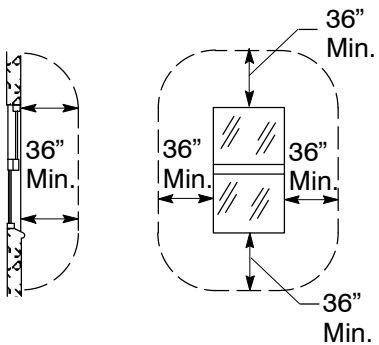

Figure 4-21
Clearance Around Windows

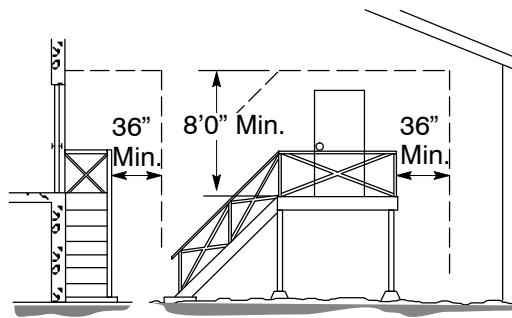

Figure 4-22
Clearance Around Doors

4.4.7. Clearance Between Service Drop Wires

The minimum-allowable radial clearance between service drop sites (i.e., 0 volts through 750 volts) in the span from the pole to the building, and a point of attachment to the building, is 3 inches. Applicants must ensure that wire supports at the building are spaced 8 inches apart, where practical.

4.4.8. Clearance From Applicant-Owned Service Poles

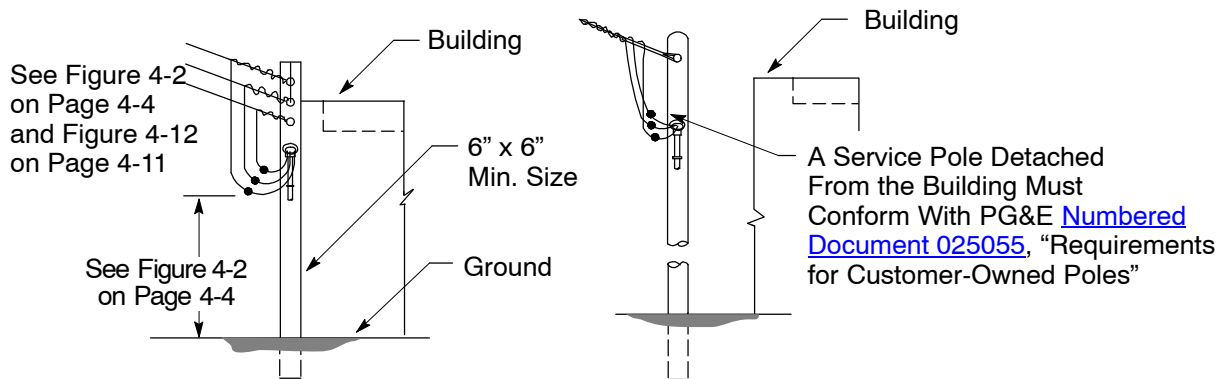

Figure 4-23
Service Attachment Structure or Service Pole Secured to a Building

Figure 4-24
Service Pole Detached From a Building

4.5. Service Attachments

Applicants must ensure that utility service drops (i.e., 0 volts through 750 volts) are **not** attached directly to metal roofs.

4.5.1. Attaching Low-Voltage, Residential, Overhead Service Drops

Applicants must ensure that the service drop's point of attachment to the building is high enough to provide the minimum legal clearances shown in Figure 4-2 on Page 4-4.

Subsection 4.6., "Attachment Structures (Periscopes)," found on Page 4-21, provides information on installing and using periscopes as attachment structures.

Whenever practical, attach the service drops below the level of the service weatherhead, as shown in Figure 4-29, "Cable (Single Spool)," and Figure 4-30, "Open Wire or Cable (Cable Shown)," both of which are found on Page 4-16, and Figure 4-39, "Unbraced Periscope Structure (Residential and Nonresidential)," found on Page 4-23.

In all installations, PG&E connects to the applicant's service-entrance conductor **below** the level of the service weatherhead. Drip loops are included at the entrance of each conductor to the service weatherhead. These drip loops prevent moisture from penetrating the installations.

The standard service attachments shown in Figure 4-25 through Figure 4-30, all representing "0-Volt Through 300-Volt Service at Residential Premises" and found on Page 4-16, are designed according to the CPUC's *State Building Standards Electrical Regulations*, to California electrical code, and to PG&E requirements. Local authorities may have additional requirements.

NOTE: PG&E will attach a service knob to a stud (e.g., 2 inch x 4 inch) or rafter, if possible. PG&E will **not** mount the service knob directly to the roof or attach it to corner trim or roof trim without a 2 inch x 4 inch-sized stud or larger. Figure 4-36, “Building Attachment–Service Knob,” Detail A, found on Page 4-20, provides the requirements for attaching service knobs.

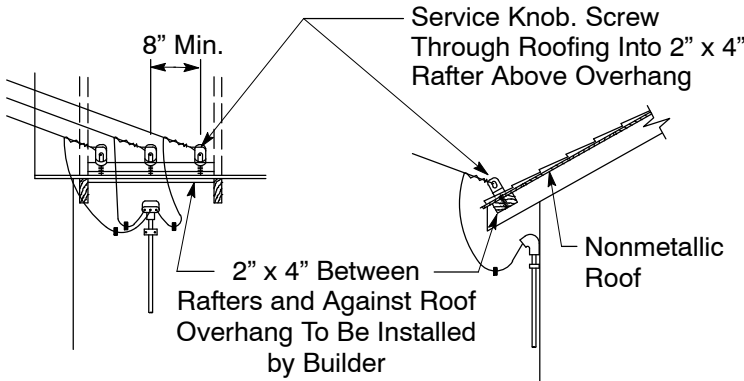

Figure 4-25
Open Wire

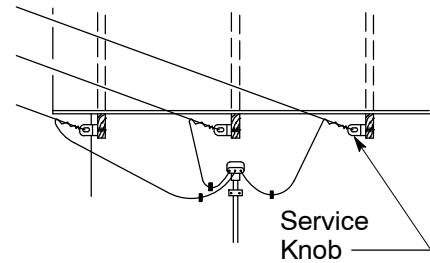

Figure 4-26
Open Wire or Cable
(Open Wire Shown)

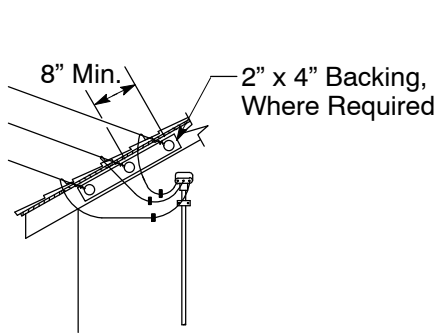

Figure 4-27
Open Wire or Cable (Open Wire Shown)

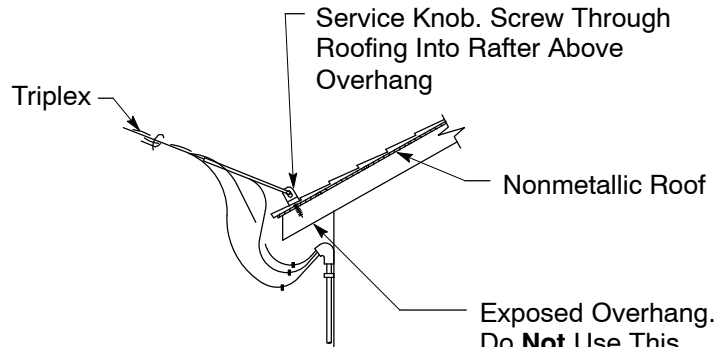

Figure 4-28
Cable (Using Triplex)

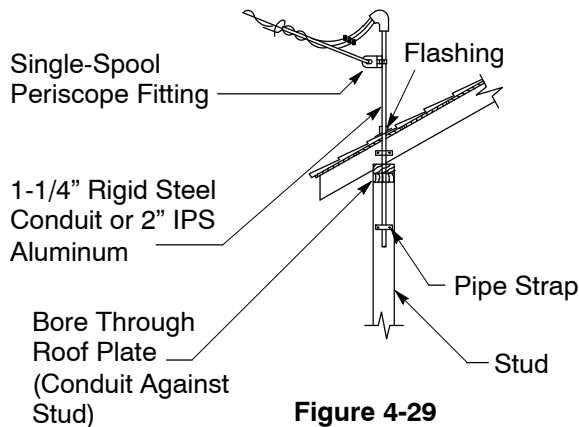

Figure 4-29
Cable (Single Spool)

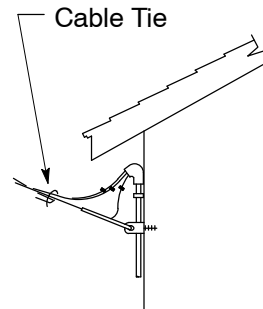

Figure 4-30
Open Wire or Cable
(Cable Shown)

0-Volt Through 300-Volt Service at Residential Premises

4.5.2. Attaching Low-Voltage, Nonresidential, Overhead Service Drops

When applicants plan to install service-entrance wiring larger than that shown in Figure 4-31 through Figure 4-34, all representing “Service to Nonresidential Premises” and found on Page 4-18, they must consult PG&E **before** they begin construction to obtain instructions on attaching the wiring properly.

Figure 4-31, “Service Drop Cable, 4/0 and Smaller, Triplex or Quadruplex,” shows applicants how to attach the wiring using service knobs in either concrete or masonry walls. Service knobs must be screwed into wood-frame walls.

Figure 4-32, “New Wall, 1/0 kcmil to 397.5 kcmil Aluminum,” shows applicants how to attach the wires using insulated clevises on concrete walls. For wood-frame walls or masonry walls (e.g., brick, hollow tile, cinder block), applicants must bolt the attachments through the wall. Where service is attached to masonry walls, applicants must install bracing or attachment structures.

When it is practical to do so, applicants must attach service drops **below** the level of the service weatherhead.

PG&E will furnish the bolts and insulators needed to secure the service drop to the building or attachment structures. Applicants can attach the service drop to the walls or to periscope structures either horizontally or vertically.

The wire sizes shown in Figure 4-31 through Figure 4-35 refer to service drops, not to service-entrance wires.

Open wiring, or drip loop, installed between the service drop attachment and the service weatherhead, must **not** exceed 3 feet.

Applicants must install periscope structures as illustrated in Figure 4-39 on Page 4-23. See Subsection 4.6. on Page 4-21 for additional information on installing periscopes and using periscopes as attachment structures.

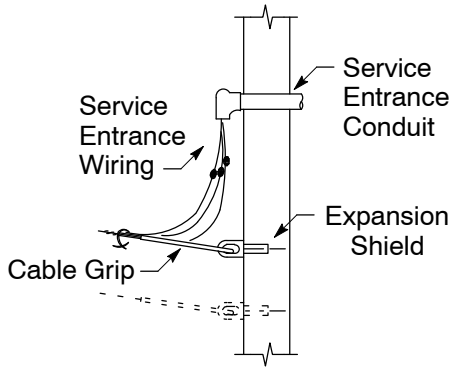

Figure 4-31
Service Drop Cable, 4/0 and Smaller,
Triplex or Quadruplex

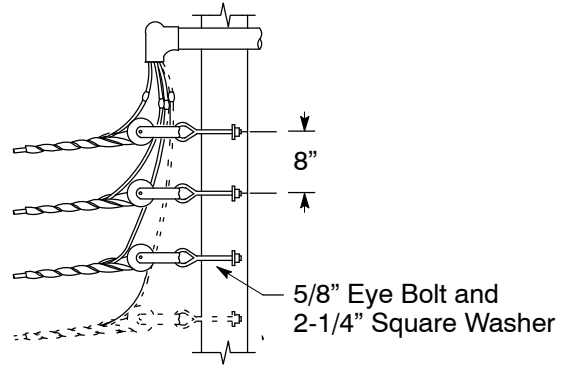

Figure 4-32
New Wall, 1/0 kcmil¹ to 397.5 kcmil Aluminum

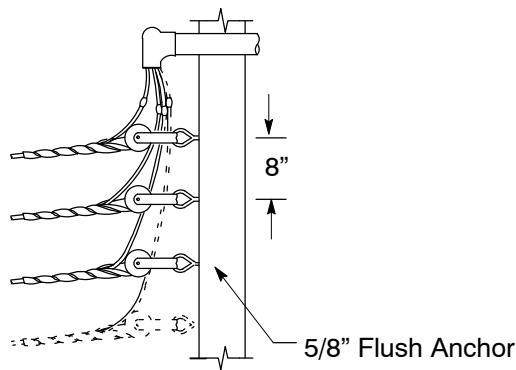

Figure 4-33
New or Existing Wall, 1/0 kcmil¹ to 397.5 kcmil Aluminum

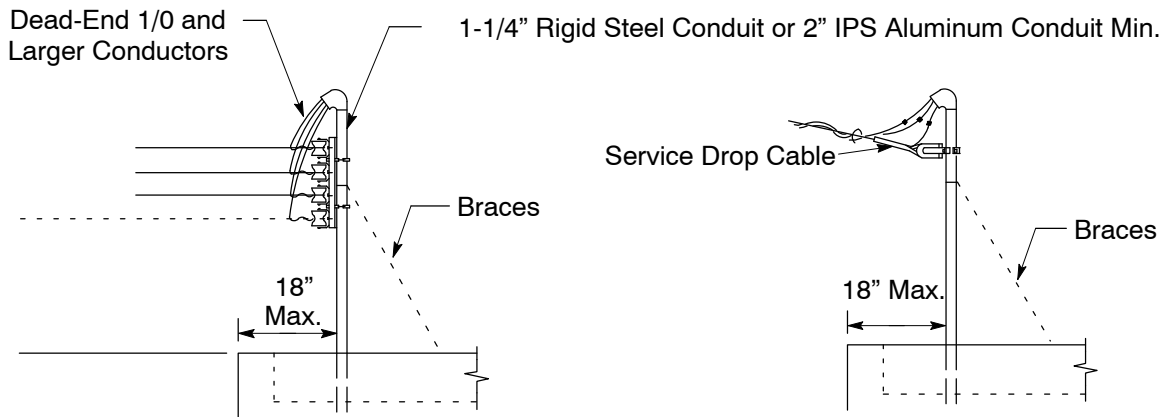

Figure 4-34
Open Wire Service, #4 to 397.5 kcmil¹ Aluminum

Figure 4-35
Service Drop Cable

Service to Nonresidential Premises

Notes in reference to Figure 4-32, Figure 4-33, and Figure 4-34.

1. kcmil: a thousand circular mils

4.5.3. Special Service Attachment Requirements: Areas Subject to Heavy Snow Loading

The following special requirements apply to service drops installed in snow-loading areas. PG&E has designed these requirements to minimize storm damage.

- A. Applicants must ensure that the span length of triplex or quadruplex service drop cable used in snow-loading areas is 125 feet or less.
- B. Applicants should locate the service weatherhead as high as practical to keep the weatherhead clear of deep snow.
- C. Applicants should try to attach service drops to house gables, where practical. This type of attachment protects the service and meter equipment from being impacted by snow and ice as it slides off the roof.
- D. PG&E will attach a service knob to a stud, if possible. PG&E will **not** mount the service knob directly to the roof or attach it to corner trim or roof trim. Figure 4-36, “Building Attachment – Service Knob,” Detail A, found on Page 4-20, provides the requirements for attaching service knobs.
- E. Applicants should install a self-supported, periscope attachment structure according to the requirements specified in Subsection 4.6. on Page 4-21 and Table 4-4, “Maximum Distance ‘L’ (Inches From the Service Attachment to the Top Periscope Support),” found on Page 4-20.

Typically, periscope attachment structures that are installed as specified in Subsection 4.6. and Table 4-5, “Maximum Mast Height Above the Roof *Without* Bracing,” found on Page 4-22, will provide a sufficiently rigid service-drop support to withstand the expected snow loading. In areas above 3,000 feet, use the construction methods shown in Figure 4-36, where practical.

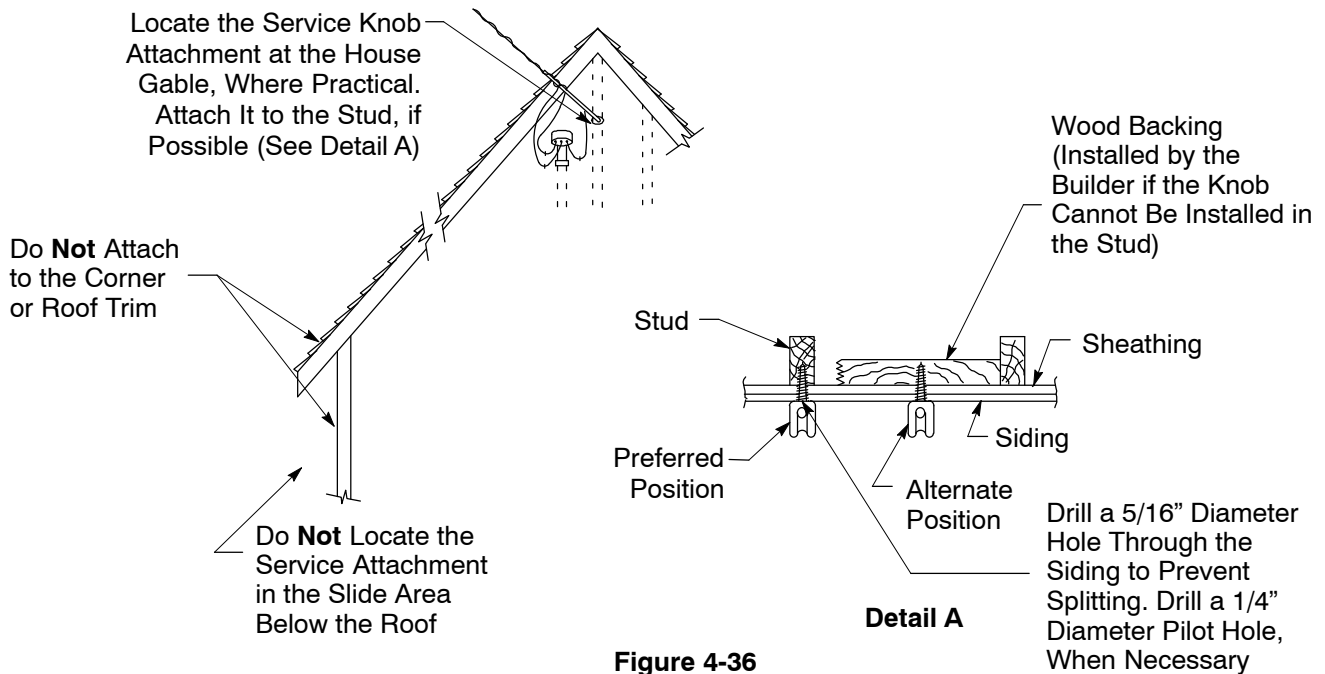

Figure 4-36
Building Attachment-Service Knob

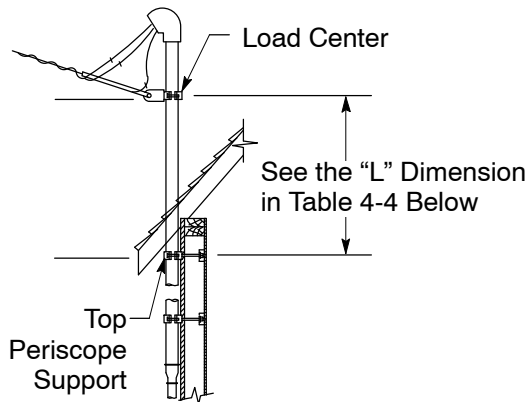

Figure 4-37
Self-Supported Periscope Attachment Structure

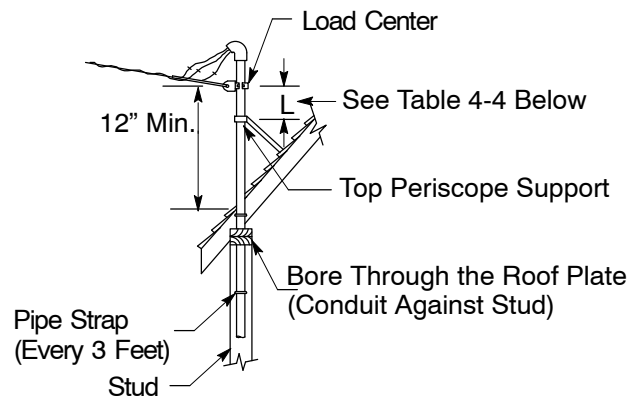

Figure 4-38
Braced Periscope Attachment Structure

Table 4-4 Maximum Distance “L” (Inches From the Service Attachment to the Top Periscope Support)

Type of Service Periscope	IPS Size of Service Periscope (In Inches)					
	1-1/4 ³	1-1/2 ³	2 ³	2-1/2	3	4
GRS ¹ or IMC ²	5	7	11	22	36	57
Aluminum	Not Permitted		4	9 ³	14	26

¹ GRS: galvanized rigid steel

² IMC: intermediate metal conduit

³ Brace the periscope as shown in Figure 4-38 to maintain a sufficient clearance over the roof.

4.6. Attachment Structures (Periscopes)

An attachment structure is a support that connects the service drop to the structure while maintaining the clearances required for the service drop. Applicants must ensure that the service drop maintains the required clearance at its point of attachment to the periscope, mast, or other attachment structure. These clearances are mandated by the CPUC's [G.O. 95](#).

Applicants can connect service drops to attachment structures in either one of two ways.

- A. Connect by using either spools or insulators that are installed on a building.
- B. Connect by using a mast constructed of one of the following materials.
 - Rigid, galvanized steel pipe or conduit
 - Galvanized angle iron
 - Wood
 - Other suitable material

To provide structural support for periscopes, applicants should use a heavy-duty, 2-hole pipe strap every 3 feet, secured by 3/8-inch x 3-inch lag screws (minimum size). Structural support is required at the location shown in Figure 4-39, “Unbraced Periscope Structure (Residential and Nonresidential),” on Page 4-23.

When applicants must install attachment structures to maintain the required clearances, they must contact PG&E for approval **before** constructing the structures. PG&E must ensure that attachment structures meet all of the applicable legal requirements.

Applicants must install and maintain these attachment structures at their expense.

The attachment structures must be strong enough to support the service drop wires and service attachments. Applicants may use service-entrance conduit as attachment structures. In this case, the periscope must be a minimum 1-1/4-inch GRS conduit or IMC, or 2-inch IPS rigid aluminum conduit. Applicants may **not** use plastic conduit as an attachment structure. Subsection 4.5.3., “Special Service Attachment Requirements: Areas Subject to Heavy Snow Loading,” on Page 4-19, provides applicants with additional requirements when using attachment structures in snow-loading areas.

When applicants use attachment structures, either on exterior walls or on roof structures, they must ensure the attachment structures provide the required clearances. Additionally, applicants must ensure that buildings are constructed or reinforced to support the weight of the attachment structure and fitting. Buildings must be able to withstand the pull of the service wires. Applicants must furnish all of the materials required to install the attachment structures **except** the racks, bolts, and insulators needed to secure the service wires. PG&E will supply those parts.

Applicants may **not** attach communications conductors, such as those used for telephone or cable television service, to the electric supply's power-service mast or attachment structure. Applicants can attach **only** electric-utility, power-supply, service-drop conductors to the electric-supply, power-service masts or attachment structures.

4.6.1. Periscope Clearances and Bracing Requirements

Applicants must ensure that periscopes and raceway-type service masts extend at least 12 inches above any roof or eave they may penetrate. Applicants may be required to raise periscopes and raceway-type service masts when using them as attachment structures and/or to obtain the appropriate clearances for service drop conductors. For more information, see Figure 4-13 through Figure 4-16, all found on Page 4-13. Also, see Figure 4-34, “Open Wire Service, #4 to 397.5 kcmil Aluminum,” and Figure 4-35, “Service Drop Cable,” found on Page 4-18. Finally, see Figure 4-36 through Figure 4-38, found on Page 4-20.

Applicants may have to brace periscopes that project above the roof lines, as shown in Figure 4-39 and Table 4-5. An acceptable method of bracing is illustrated in Figure 4-34 and Figure 4-35. Table 4-5 lists the maximum periscope heights that applicants can install **without bracing** for different types of conduit.

The periscope (i.e., mast) height without bracing is limited to 30 inches above the roof in either of the following two locations.

- Where the service drop is installed through trees.
- Where trees or tree branches may strike or cause unplanned loading on the service drop.

Applicants must ensure that unbraced periscopes projecting above roofs or eaves are continuous **without couplings** from the point where the utility service drop is attached to the periscope to 30 inches below the roof or eave. When the periscope structure requires support above the roof, applicants must ensure that it is braced, **not guyed**, as shown in Figure 4-38. The brace must be located as described in Table 4-4. When applicants need to brace periscope structures, the bracing must consist of two galvanized steel members installed at an approximate 90° spread. Braces must consist of a minimum 3/4-inch galvanized steel pipe or 1-1/4-inch x 1-1/4-inch x 1/8-inch galvanized steel angles.

Table 4-5 Maximum Mast Height Above the Roof *Without* Bracing¹

(IPS) Conduit Size		Maximum Height <i>Without</i> Bracing
GRS ² or IMC ³	Aluminum	
All Measurements in Inches		
1-1/4	2	42
1-1/2	2-1/2	42
2	3	54
Larger	Larger	78

¹ See Subsection 4.5.3. on Page 4-19 for snow-loading area requirements.

² GRS: galvanized rigid steel

³ IMC: intermediate metal conduit

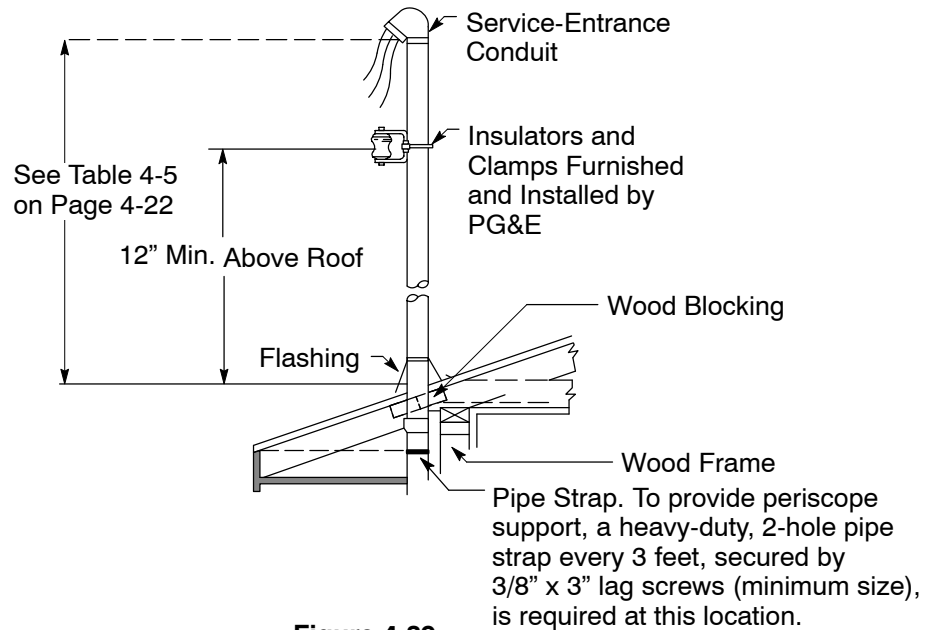

Figure 4-39
Unbraced Periscope Structure (Residential and Nonresidential)

4.7. Service Weatherheads

Typically, applicants should **not** locate the service weatherhead on exterior walls that are less than 2 feet from a common property line. The service weatherhead should be higher than the point of service attachment.

Applicable California state laws require applicants to locate the service weatherhead so that they maintain the minimum clearances specified in Subsection 4.4., “Service Drop Clearances,” found on Page 4-3, through Subsection 4.5., “Service Attachments,” found on Page 4-15. These minimum clearances also apply to the service drop and the open sites between the service weatherhead and the service drop’s point of attachment.

In some instances, applicants may need to install the service weatherhead and related open wires at an elevation greater than the minimum required clearances. Adding the extra height ensures that the installed service drops maintain the required clearances above the ground and any affected structures. Also the required clearances may be greater than local electrical codes.

A **service weatherhead** must be located **above** the service-drop conductor’s point of attachment; however, the **service-drop attachment** may be located **above** the service weatherhead if **both** of the following conditions are met.

- A. If it is impractical to attach the service drop below the level of the service weatherhead.
- B. If the attachment point on the service-drop conductor is located less than 24 inches from the service weatherhead.

Ensure that the length of the open-wire drip loop does **not** exceed 3 feet.

4.8. Service-Entrance Conductors

Applicants must furnish, install, and maintain the service-entrance wiring and service equipment beyond the point where it attaches to PG&E's overhead service drop.

The type and size of service-entrance wires must conform to applicable legal requirements and must be approved service-entrance cable. If applicants use an approved service-entrance cable, they must ensure that the service-entrance wires are enclosed either in continuous metallic tubing or in rigid conduit of a type and size to conform to applicable requirements, but preferably 1-1/4 inches or more.

NOTE: On periscope-type installations, use a minimum 1-1/4-inch GRS or IMC, or 2-inch IPS, rigid aluminum conduit.

If applicants use SE-type service-entrance cables between the service weatherhead and meters, they must ensure that the SE-type cables are **not** concealed. Also, applicants must ensure that service entrances are rain tight by using approved fittings.

In residential and small commercial installations, applicants may install short-radius conduit fittings (i.e., LBs, service elbows) in the overhead, service-entrance conduit system.

Because this conduit system penetrates the outer building wall, applicants must install the short-radius conduit fittings with covers that prevent water from penetrating the fittings. The covers also must be sealable by PG&E personnel.

NOTE: Short-radius conduit fittings should **not** contain splices or taps.

The drip loop is the length of exposed wire between the service weatherhead and the service drop. Applicants must **not** use more than 3 feet of exposed, open wiring to form the drip loop.

To create drip loops, an applicant should install a minimum 18 inches of service-entrance wiring that extends out from the service weatherhead. In cases where the service-entrance open conductors pass over a roof or firewall with a minimum clearance of 12 inches, applicants must provide enough wire for PG&E to connect to the service drop and to obtain the required 12-inch minimum clearance above the building.

PG&E will connect the Company's service conductors and the applicants' service-entrance conductors below the weatherhead.

PG&E will furnish and install connectors for joining the service-entrance conductors to the service drop. Drip loops must **not** extend around the corner of a building; however, the service weatherhead may be located on the same face of the building as the service-drop attachment. The service-entrance conduit or cable may be extended around the corner of the building to the meter and service switch.

Do **not** install conductors other than service-entrance conductors in the conduit leading to the meter.

4.9. Applicant-Owned, Installed, or Furnished Wood Poles

PG&E project coordinators will explain the requirements of [Electric T&D Engineering & Technical Support Bulletin 2004-08](#), “Inspection of Customer/Contractor Provided Poles,” (filed as “For Reference Only”) to ensure that applicants are familiar with the requirements for installing and using the wood poles.

For poles that will have a final height greater than 20 feet above ground level, the Federal Aviation Administration (FAA) may require the applicant to file a notice a minimum of 45 days before installing the pole. The FAA may issue a determination of hazard to air navigation and recommend actions to mitigate or eliminate the hazard. Please contact your PG&E project coordinator for additional information.

After meeting with project coordinators and finalizing their installation plans, applicants must notify their local PG&E project coordinators **before setting** wood poles. It is critical that applicants who own, install, or furnish approved wood poles to which PG&E can attach equipment or facilities, or to which PG&E can furnish or supply permanent electric service, meet the requirements of [Numbered Document 025055](#), found in [Appendix C](#). PG&E field inspectors will approve the installation of poles that meet Company requirements.

PG&E field inspectors verify the following, specific requirements for applicant-furnished poles before approving their installation.

- A. The poles must be supplied and treated by a PG&E-approved supplier.
- B. The applicant must obtain and provide PG&E with a copy of a “Certificate of Treatment” from the pole supplier. That certificate must indicate that the pole was treated according to the requirements of both the American Wood Preserver’s Association and the American National Standards Institute (ANSI).
- C. Applicants must ensure that new poles are branded or tagged. This identification must be either 10 feet from the pole butt for poles less than 55 feet long or 14 feet from the pole butt for poles more than 55 feet long. The brand must include the following four identifiers.
 - The manufacturer’s name
 - The month and year the pole was treated
 - The wood species
 - The preservative used to treat the pole
- D. Poles greater than 40 feet long that will support PG&E primary facilities must be through-bored at the ground line.
- E. PG&E must inspect and approve used poles **before** they are reused (i.e., PG&E facilities are reinstalled on the poles). PG&E-owned poles that have been removed from service and will no longer be used by PG&E cannot be reused as customer-owned poles. The PG&E field inspector must verify that the poles meet the dimensional and test requirements for reused poles. These requirements are described in PG&E Procedure [TD-2325P-01](#), “Wood Poles–Testing, Reinforcing, and Reusing.”

If installing **overhead temporary services**, refer to [Numbered Document 025055](#), found in [Appendix C](#).

4.10. Required Vegetation Clearances

The state of California requires electric utilities to keep electric lines (i.e., high-voltage lines) cleared of vegetation. All newly constructed distribution lines and existing lines must meet these requirements.

NOTE: PG&E may determine that the distribution line should be installed underground, or that trees should be removed, if the planned line extension does **not** meet the clearance requirements between existing trees and overhead electric lines. See new options for commercial agricultural orchards in Subsection 4.10.5. on Page 4-30.

4.10.1. General Requirements

When establishing new overhead services, and/or when building or remodeling structures near high-voltage lines, poles, or towers, applicants must research planting regulations and follow the rules established here.

NOTE: Applicants must consider safety and access for repairs when planting near an overhead electric service.

- A. Where required, applicants must establish clearances as described in California Public Resource Code (PRC) Division 4, “Forests, Forestry and Range and Forage Lands,” Part 2, Chapter 3, [Section 4292](#). PG&E can exempt applicants if the vegetation around power poles at the completed construction site will be well irrigated, low growing, and not highly flammable. In general, do **not** plant trees near power poles or towers.
- B. For electric **distribution**, high-voltage lines rated up to 60,000 volts, applicants must establish a 15-foot “low-growth” zone on both sides of all new lines. Also applicants must **not** plant trees that exceed 25 feet in height at maturity under or within 15 feet of **distribution** power poles. The zone under the electric power lines should be a low-growth, tree-planting zone and/or a shrub- and flower-planting zone. PG&E recommends planting shrubs and flowers in low-growth zones to ensure compliance. Figure 4-40, “Illustration of 15-Foot Clearance, Low-Growth Zone,” and Figure 4-41, “Grass and Shrubs Recommended Under Service Wires,” both on Page 4-27, illustrate low-growth zones and show how the 15-foot clearance is measured from the center of the pole.
- C. For all electric **transmission**, high-voltage lines rated greater than 60,000 volts, applicants must **not** plant trees within the right-of-way easement of the **transmission** poles or towers. Applicants must follow a “no-growth” zone inside rights-of-way areas, including under the electric power lines. The zone outside the rights-of-way areas is a “low-growth” zone, tree-planting zone, and/or a shrub-and-flower planting zone. Figure 4-42, “Grass and Shrubs Recommended Under Transmission Wires,” on Page 4-27, illustrates a no-growth zone.
- D. Applicants must ensure that a thorough inspection is made of proposed construction areas. Dead, dying, diseased, or hazard trees tall enough to fall into the proposed power lines must be removed. Hazard trees are defined as any tree having a structural defect that may cause the tree, or a portion of the tree, to fall either on someone or on something of value.

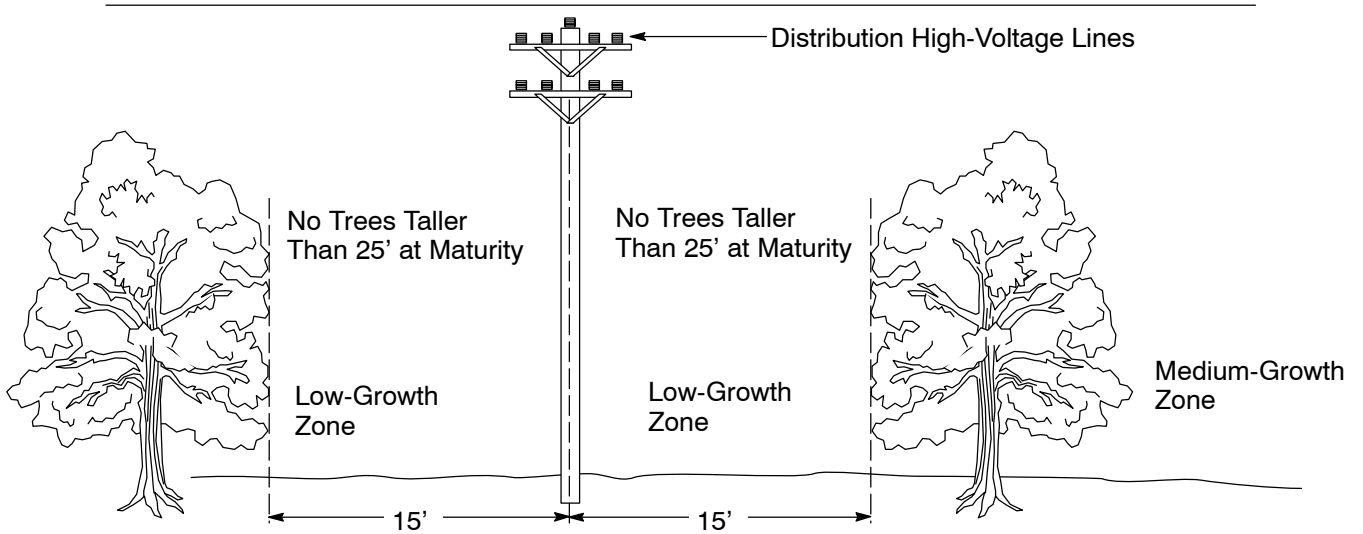

Figure 4-40
Illustration of 15-Foot Clearance, Low-Growth Zone

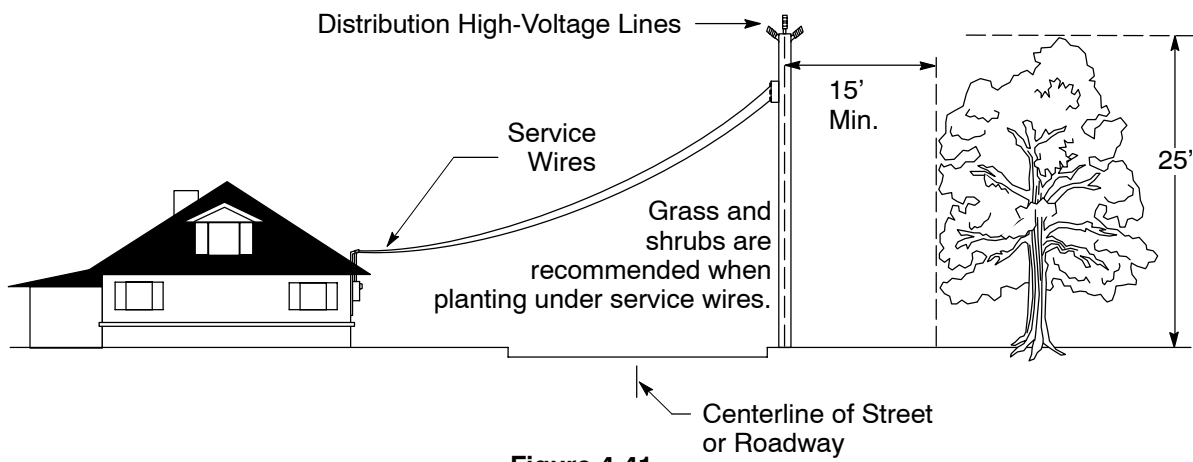

Figure 4-41
Grass and Shrubs Recommended Under Service Wires

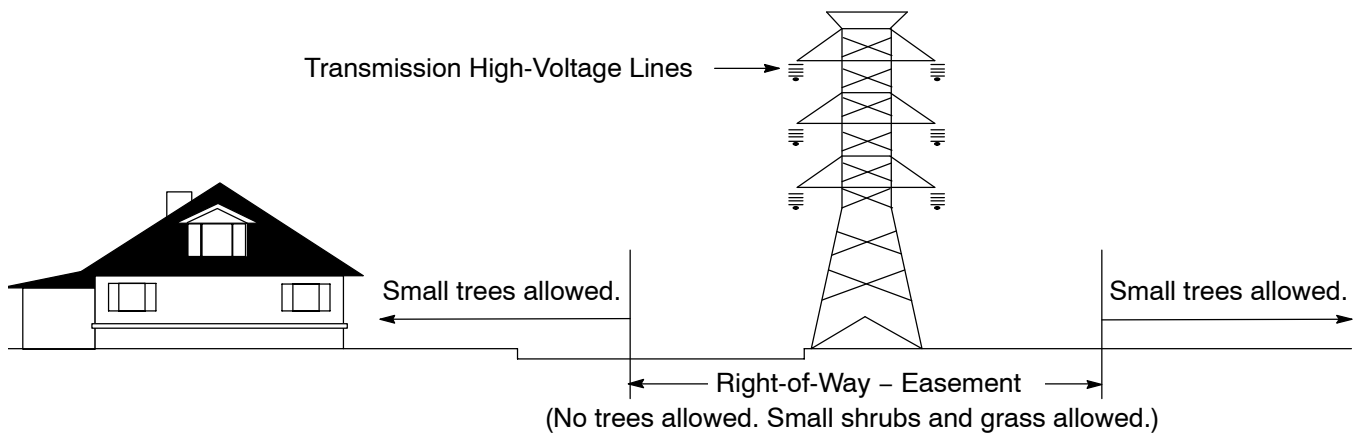

Figure 4-42
Grass and Shrubs Recommended Under Transmission Wires

- E. Applicants can contact PG&E’s vegetation management personnel to obtain more information about codes or regulations and to schedule field inspections for construction sites. Vegetation management personnel perform field inspections to identify clearance requirements or hazard trees.

4.10.2. Planning Requirements

When planning and routing high-voltage overhead electric lines, applicants must avoid areas with heavy tree growth. See the tree-planting matrix tables (Tables B-1 through B-7 starting on Page B-2) in [Appendix B](#). Building plans should indicate where overhead lines pass within the boundaries of the construction and landscape areas, as shown Figure 4-43, “Alternative Routes to a House Showing High-Voltage Lines and Tree-Clearance Zones,” below, and Figure 4-44, “Development Area,” on Page 4-29.

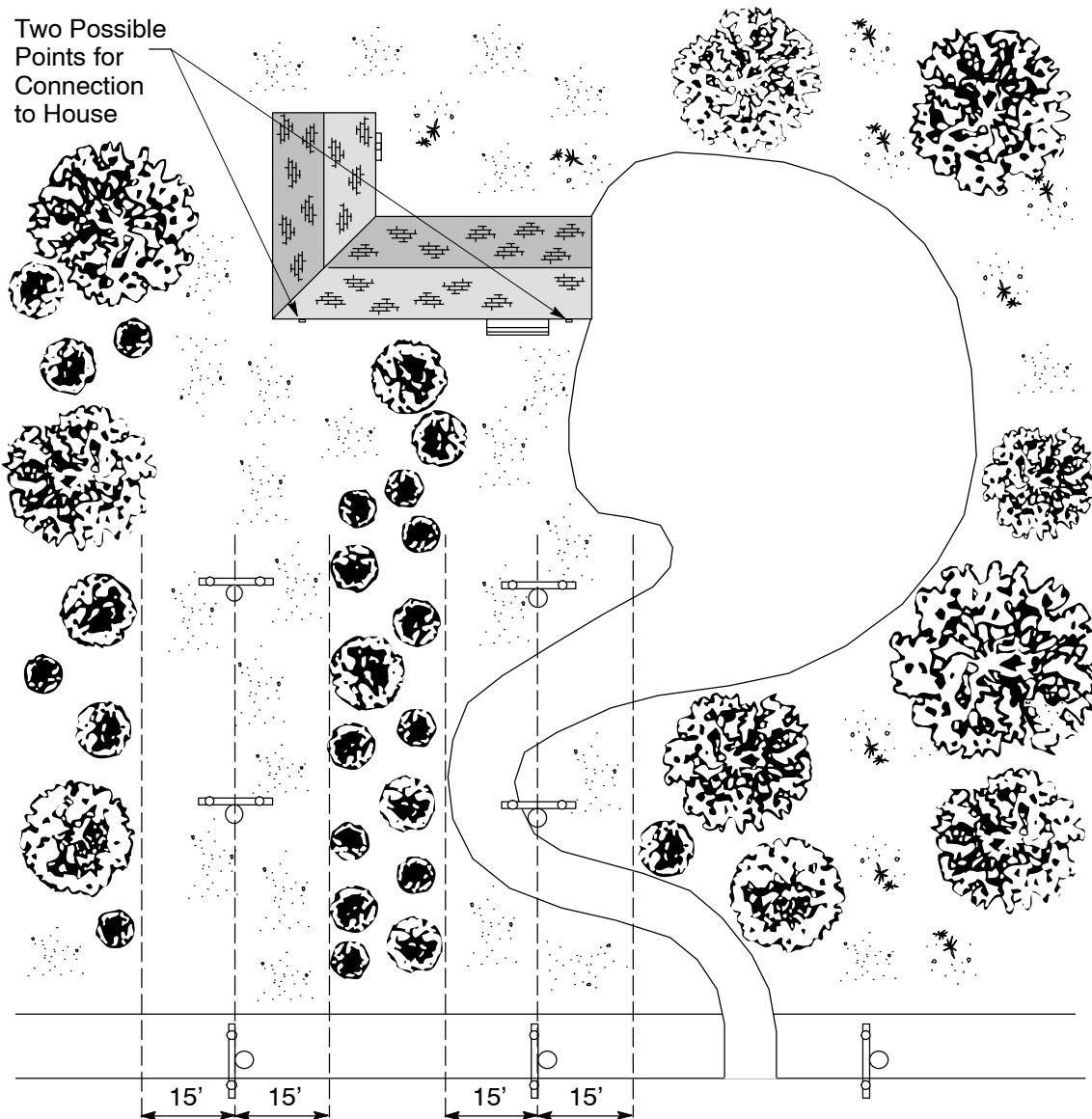

Figure 4-43
Alternative Routes to a House Showing High-Voltage Lines and Tree-Clearance Zones

4.10.3. Existing Overhead Lines Adjacent to Developments

Most new developments are designed to ensure that power lines are built underground. However, one or more sides of the construction area may be bordered by existing power lines. When planning landscape improvements, applicants must plant only lower-growing tree species under and near overhead electric lines.

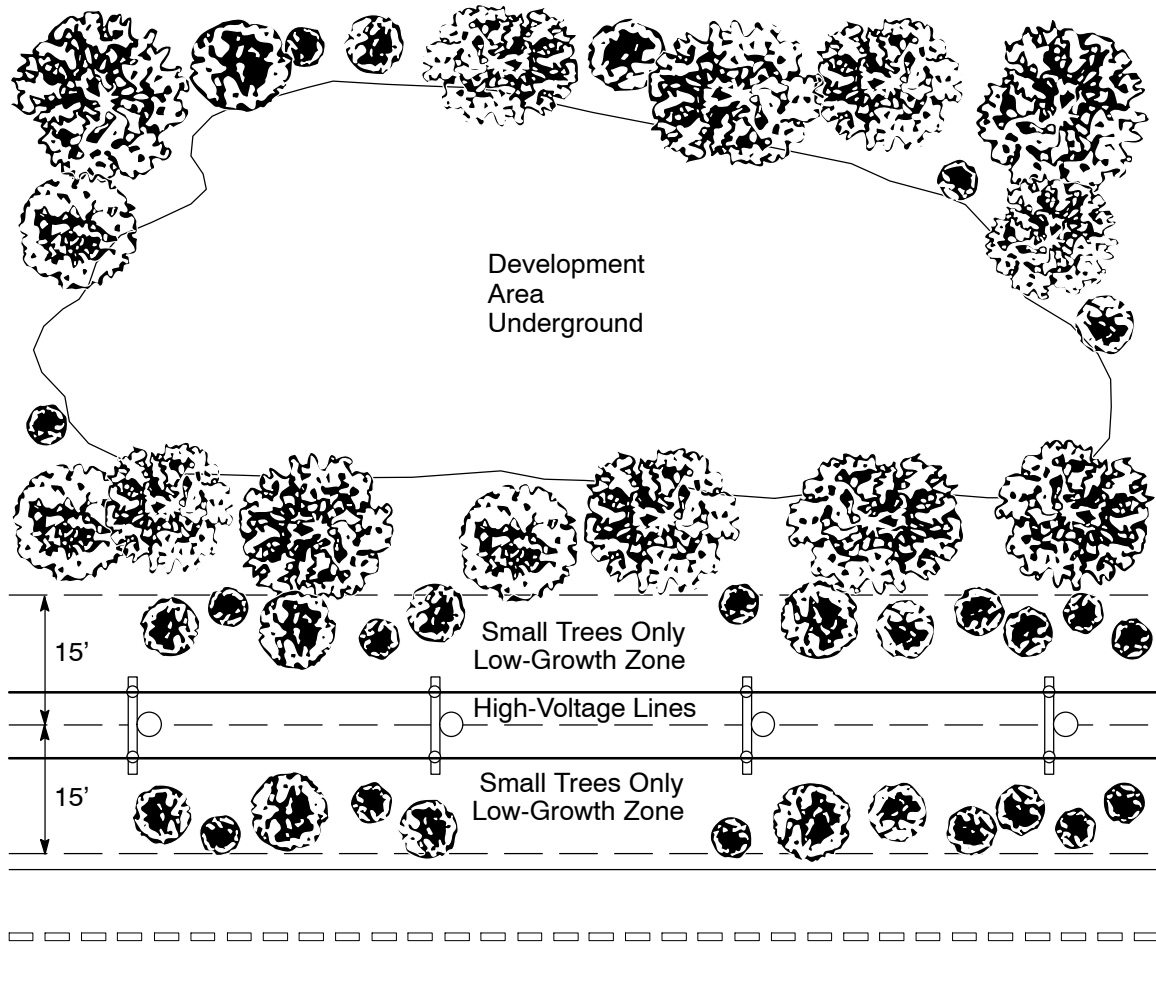

Figure 4-44
Development Area

4.10.4. Line Extensions

Line extensions must be constructed with a 15-foot clearance on either side of high-voltage power poles. Applicants must clear the area from one end of the line extension to the final connection point before construction on the line extension begins. Figure 4-43 on Page 4-28 illustrates an approved method for clearing affected areas. Also, any hazard trees identified during the PG&E inspection that are located outside of the 15-foot clearance zone on either side of the power poles should be removed before construction begins on the line extension. PG&E will **not** connect new lines to the existing distribution system until the applicant provides adequate clearance from the trees.

4.10.5. Primary Overhead Distribution Poles in Commercial Orchard Installations

When planning and routing high-voltage, overhead electric lines within a commercial orchard, agricultural customers may request the installation of taller poles than normally would be installed to eliminate or minimize PG&E's need for future vegetation pruning. The applicant may be required to make a nonrefundable, one-time payment for the additional cost of installing taller poles. Contact the PG&E project coordinator for more information. In addition, applicants should work with the PG&E project coordinator to choose a route for the overhead distribution facilities that does not conflict with the orchard trees and eliminates the need for future vegetation pruning.

When planting near overhead electrical service drops, applicants also must consider safety and access to the electric facilities when irrigation pumps and other electrical loads require repair.

4.10.6. Removing Vegetation Near Existing, High-Voltage, Energized Lines



CAUTION

Because safety is the Company's highest priority, PG&E recommends that all vehicles, equipment, tools, and people maintain a minimum 10-foot distance from all high-voltage power lines. Refer to [Section 1](#), "General," Table 1-2, "Minimum Safe Working Distances (Scaffolds, Equipment, Tools, Structures, and People)," and Table 1-3, "Minimum Safe Working Distances (Boom-Type Lifting or Hoisting Equipment)," both on Page 1-9, for the minimum safe working distances.

Applicants or unqualified tree-trimming contractors should **never** attempt to trim or remove trees that are within 10 feet of high-voltage power lines (i.e., conductors).

If it is necessary to trim or remove trees located within 10 feet of a high-voltage power line, applicants **must** notify PG&E at **1-800-743-5000**.

Generally, high-voltage power lines are any overhead lines that connect from pole to pole. These lines typically are 600 volts and greater. Post a "HIGH VOLTAGE" sign on the poles or crossarms, as shown in Figure 4-45, "High-Voltage Marker on Poles and Crossarms," on Page 4-31. However, applicants should contact PG&E for assistance if a line's voltage is unknown, and should **always assume that lines are high voltage**.

During PG&E's normal tree-trimming schedule, contractors qualified to perform high-voltage line clearances will prune or remove trees at no cost to applicants to create a safe distance between the vegetation and high-voltage power lines.

If it is necessary to trim a tree that is closer than 10 feet from an overhead power line **before** PG&E's normal tree-trimming schedule, applicants may hire a contractor qualified to perform high-voltage line clearances to prune the tree to a safe distance away from the electric lines. Again, unqualified persons should **not** perform this job. Applicants should contact PG&E to obtain the tree-trimming schedules for their areas.

There are regulations and statutes that dictate the requirements for working around high-voltage power lines. The [California Occupational Safety and Health Administration \(Cal/OSHA\)](#) requires that persons working within certain distances of overhead power lines be qualified and trained properly. For details, see the *California Code of Regulations*, Title 8, Division 1, Chapter 4, Subchapter 5, Group 2, "High-Voltage Electrical Safety Orders," [Article 37](#), "Provisions for Preventing Accidents Due to Proximity to Overhead Lines," and [Article 38](#), "Line Clearance Tree Trimming Operations."

In addition, the [California Penal Code](#) makes it a **crime for any person to work within 6 feet of a high-voltage power line**. For details and additional information about this misdemeanor, see the California Penal Code, Part 1, Title 10, [Section 385\(b\)](#).

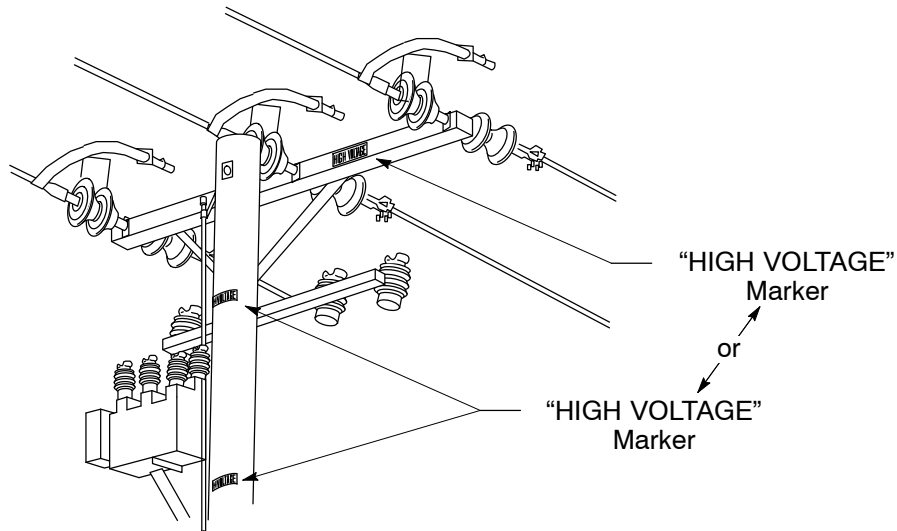

Figure 4-45
High-Voltage Marker on Poles and Crossarms

For PG&E-recommended and PG&E-prohibited trees, see the the tree-planting matrix tables (Table B-1 through Table B-7 starting on Page B-2) in [Appendix B](#).

This Page Intentionally Left Blank

SECTION 5
ELECTRIC METERING:
GENERAL

SECTION 5 ELECTRIC METERING: GENERAL

Section 5 Electric Metering: General

5.1. Scope

This section of the manual is designed to help applicants, engineers, and contractors plan acceptable electric metering installations for the electric service supplied by Pacific Gas and Electric Company (PG&E/Company). The information and requirements described are applicable to Section 6 through Section 11.

For help with determining the service rating of customer equipment see Subsection 1.14. located on Page 1-12.

NOTE: See new service and current transformer (CT) installation requirements in Subsection 5.2.4., “Requirements for the Installation of Secondary Terminations (0–600 Volt) in Metering Equipment Requiring CTs,” on Page 5-4.

5.2. General Conditions and Responsibilities

5.2.1. Approved Metering and Service Termination Equipment

All service termination and metering equipment must conform to nationally recognized standards and meet all applicable certification requirements. Nationally recognized standard organizations include, but are not limited to, the following: [National Fire Protection Association \(NFPA\)](#), [National Electrical Code \(NEC\)](#), [National Electrical Manufacturers Association \(NEMA\)](#), [Underwriters Laboratories \(UL\)](#), or Occupational Safety & Health Administration’s (OSHA’s) [Nationally Recognized Testing Laboratory \(NRTL\)](#) Program. The equipment also must meet the requirements specified in the [Electric Utility Service Equipment Requirements Committee \(EUSERC\)](#) manual and be approved by PG&E for use in construction projects.

NOTE: Employees perform an onsite field inspection of the equipment and installation and provide final approval only after ensuring that all of the specified requirements have been met.

5.2.2. Drawing Submittal Requirements for Metering and Service Termination Equipment

Applicants must meet the requirements in Item A. through Item D., below and on Page 5-2, when installing electric metering and service termination equipment. This applies to residential and nonresidential applications and includes meter panels, pedestals, panelboards, and switchboards that are wall-mounted, pad-mounted, pole-mounted, or on panel board construction.

- A. Submit drawings for equipment with current ratings of 320 amperes (amps) or above to PG&E in triplicate (i.e., either paper copies or electronically) for review and pre-approval by the local meter shop personnel or meter specialist.

- B. Also, submit drawings for newly designed metering equipment or for equipment that has been modified from existing designs as shown in the *Greenbook* or EUSERC manuals. This applies to metering equipment of any current rating. Drawings must be sent to the Meter Engineering Department for review. The review process could take 6 months or longer.
- C. Ensure that submittals contain specific references from either the [EUSERC](#) manual, this *Electric and Gas Service Requirements (Greenbook)* manual, or both. When using *Greenbook* references, include the applicable subsection(s), figure(s), and page number(s). For [EUSERC](#) references, use the drawing and sheet numbers.
- D. Ensure that submittals contain specific references for each component or section included with the equipment. Provide a detailed summary of the specification information in the beginning of the submittal, as well as on all equipment figure drawings in the submittal.

5.2.3. Applicant Responsibilities

The applicant must provide, install, own, and maintain the following equipment and structures listed in Item 5.2.3.A. through Item 5.2.3.G., starting below.

- A. All meter sockets and enclosures, metering transformer cabinets, and switchboard service sections intended for utility use, unless PG&E permits a specific exception.
- B. Use only ring-type meter sockets, enclosures, switchboards, and other metering equipment approved both by PG&E and [EUSERC](#).
- C. For Overhead Service: Service entrance conductors, conduit, and a weatherhead to the point of attachment to PG&E's overhead service conductors.
- D. For Current-Transformer Panels and Switchboards: Lugs, an underground service-termination pull box, and a separate current-transformer cabinet and meter box.
- E. **All Indoor Meter Panels:** Individual, residential, or nonresidential applicants with a meter-panel rating of **any size**, installed inside a meter room or inside a building or other type of structure, must follow all of the requirements described below.
 - 1. Install, own, and maintain a separate, nominal, **2-inch** diameter conduit with pull tape inside. The conduit and pull tape must extend from the meter panel or switchboard and terminate in a [NEMA 3R](#), 6-inch x 6-inch x 6-inch enclosure located 8 feet to 10 feet above grade on the outside surface of the building.
 - 2. Follow the applicable requirements in [PG&E Bulletin TD-7001B-005](#), "SmartMeter™ Electric Network Requirements for Indoor Meter Rooms and High-Rise Building Construction," located in [Appendix B](#).

3. Do not use the conduit. The conduit is for PG&E's metering equipment only. See additional requirements in Item 5.2.3.G. below.

F. **All Indoor or Outdoor Meter Panels:** Individual, nonresidential applicants with a meter-panel rating of **500 kW or greater** must install, own, and maintain a separate, nominal, **1/2-inch** diameter conduit with pull tape inside. The conduit and pull tape must extend from the telephone service location and terminate in the meter section of the electric panel.

EXCEPTION: Approved meter-panel locations that have adequate wireless radio frequency (RF) signal capabilities may be exempted from installing the 1/2-inch phone line conduit. To request a variance, customers must submit switchboard and meter-panel drawings with the jobsite address to their local project coordinator early in the service application process. The project coordinator submits this information to the PG&E local meter shop, enabling PG&E employees to make a field determination as to whether or not the conduit should be required. Without an exemption from the meter shop, the 1/2-inch conduit is required and must be installed.

NOTE: A 500 kW minimum, 3-phase (∅) meter panel is defined as one of the following:

- 277/480 volts, 4-wire wye, and minimum 800 amps
- 120/208 volts, 4-wire wye, and minimum 1,600 amps
- 120/240 volts, 3-wire delta, and minimum 1,600 amps
- 120/240 volts, 4-wire delta, and minimum 1,600 amps
- 2,400–21,000 volts, primary service, any size

G. Conduit installed in the ground, floors, ceilings, walls, or concrete must be made of rigid steel. In any other installation location, the conduit type can be electrical metallic tubing (EMT) or better. For underground installations, the conduit must exit the pad on the outside of the switchgear...**not** inside the switchgear. See Figure 5-5, "Preferred Location of Conduits for Indoor and Outdoor Meter Panels and Switchboards," on Page 5-14.

H. For recommendations on the best locations for equipment, ask your project coordinator to **contact PG&E's electric metering department**. Questions may include the prime location for a phone interface box, the required point for conduit to exit the meter room or building, or your options in a remote location when a telephone line is unavailable.

I. Transformers rated at 120/240 volts, three-phase, 4-wire, with delta-connected service installed, must have the "high leg" (e.g., power leg, stinger leg) conductor located either in the center phase or on the right phase position. This conductor usually is designated as the "C" phase for metering purposes. Mark (i.e., identify) the conductor (e.g., high leg, power leg, stinger leg) properly. The color orange is typically used for this purpose.

On all self-contained services, the power leg must be located in the far-right phase position, usually designated as the “C” phase. Mark (i.e., identify) the conductor (e.g., high leg, power leg, stinger leg) properly. The color orange is typically used for this purpose.

- J. Applicant wiring that extends from the distribution section (i.e., branch circuits) must **not** pass through any PG&E-sealed section.
- K. Single-metered applicants with single-phase services above 400 amps should consider installing a switchboard as described in [Section 10](#), “Electric Switchboards: 0 Volts Through 600 Volts.”

5.2.4. Requirements for Installing Secondary Terminations (0–600 Volts) in Metering Equipment Requiring CTs

All non-PG&E personnel (e.g., applicant installers) who install, inspect, or supervise the installation of PG&E services, and all PG&E personnel who schedule, install, inspect, or supervise the installation of services and metering work, must follow the new construction requirements for installing secondary terminations at customer switchboards or meter panels when 600 V metering CTs have **not** been installed.

Non-PG&E personnel installing approved PG&E service-entrance conductors must contact the local PG&E project coordinator and request that the CTs be installed **before** the service-entrance conductors are installed (usually 1–2 weeks before).

To ensure the safety of field metering personnel, CTs must be installed on new services before the service conductors are terminated in the utility pull section. To prevent the secondary voltage from being energized inadvertently before the CTs are installed, all personnel should know and follow the instructions below:

- A. Do not terminate/land secondary cable at the customer panel until PG&E metering personnel install CTs.
- B. Schedule the CT installation before constructing/installing secondary terminations.
- C. If secondary terminations are installed or terminated, and CTs are not set, either establish a “Visible Open” to isolate the secondary terminations for metering personnel, or install shunts/grounds.

DO NOT PERFORM either of the actions described above before metering personnel install the CTs (as described in the [Protective Grounding Manual, Section 4B.4.2.A.2](#)) on Page 4B-29.

1. A “Visible Open” (see Subsection 5.2.4.C. above) is defined in one of the two following ways:
 - **Overhead Construction:** Open cutouts, primary jumpers not installed, OR secondary cable terminations isolated.
 - **Underground Construction:** Fuses removed (e.g., bayonet fuses at pad-mount or subsurface transformer) OR secondary cable terminations isolated.

NOTE: An open secondary breaker is not considered a “Visible Open.”

Refer to the following PG&E documents for detailed instructions about installing secondary terminations (0–600 volt) in metering equipment requiring CTs:

- [TD-2424B-002, “New Construction Requirements for Installation of Secondary Terminations in Customer Panels Requiring Current Transformer \(CT\) Installation”](#)
- [TD-2424P-01, “Distribution Transformer Operations”](#)
- [TD-6301B-001, “Installing 600 Volt Current Transformers”](#)
- [TD-6301P-01, “Electric Metering–Safe Work Procedures” Attachment 1, “Installing 600 Volt Current Transformers”](#)

Non-PG&E personnel can contact their local PG&E project coordinators to request copies of the PG&E documentation listed above.

EXCEPTION: The requirement that PG&E service conductors be installed **before** PG&E metering personnel install CTs **does not apply** to the underground, wall-mounted meter panels shown in Figure 6-4, “Underground Combination Meter and Current-Transformer Cabinet (201 Amps–400 Amps, 1Ø or 3Ø,” and Figure 7-3, “Underground Combination Meter and Current-Transformer Cabinet (201 Amps–400 Amps, 1Ø or 3Ø).” For this specific type of meter panel, the CTs must be installed **before** the service because the meter wiring and test switch block the service termination area. In this case, validate or create a controllable open point on the source and load side of the metering section.

5.2.4.1. PG&E’s Responsibilities

PG&E provides, installs, owns, and maintains all meters and metering transformers for full-service applicants. For direct access applicants, refer to [Direct Access Standards for Metering and Meter Data \(DASMMD\) in California](#) (March 1999).

5.3. Electric Meters: General Location Requirements

To determine the most satisfactory meter location and to ensure that adequate space is provided for the meter, consult a PG&E project coordinator in the project’s preliminary planning stage. All equipment clearance and working space requirements must be met.

When an electric panel is being relocated or replaced, and PG&E’s existing service conductor will be used, as determined by PG&E, the panel must be positioned so the service conductor can be reconnected properly. The existing service conductor must be able to be reconnected to the underground electric panel termination lugs or the external service-entrance conductors coming out of the weatherhead for overhead services. If PG&E needs to install additional service conductors or cables to perform the reconnect, the work and material would be at the applicant’s expense. PG&E **does not accept** cable-termination techniques using pin adaptors, cable ringing, or splicing on additional cable.

The local PG&E meter shop must approve remote meter locations before applicants locate meters away from (i.e., remote from) termination enclosures. Applicants must submit a drawing that shows the distance (in feet) and the accessible path to the remote meter location. Also, describe the size and type of conduit used to attach to the remote meter.

See Figure 6-5, “Typical Underground, Separate-Bused, Current-Transformer Cabinet and Safety-Socket Meter Box Assembly, 201 Amps–400 Amps, 3Ø and 201 Amps–800 Amps, 1Ø,” on Page 6-8, as an example of remote metering.

Applicants can avoid the time and expense of installing additional facilities or relocating existing facilities by consulting with PG&E early in the process.

5.3.1. Basic Meter Location Requirements

The following five lettered items explain PG&E’s basic meter location requirements and are subject to PG&E’s review and approval to ensure compliance. Applicants must ensure that:

- A. Locations have at least one clear and unobstructed path or entrance providing access to the working space.
- B. Nonportable illumination is provided for the working spaces around meters, metering-related equipment, and associated facilities when meters are located indoors. Also, applicants must provide a hallway or aisle leading to the meter(s) and metering equipment.
- C. Locations in elevated areas (e.g., balconies or mezzanines) or in depressed areas (e.g., basements, cellars, or underground rooms) must be accessible by either a ramp or clear stairway that conforms to building-code requirements.
- D. PG&E has provided advanced approval when potential locations are not in conflict with prohibited meter locations and are on walkways, alleys, or driveways that provide access to commercial or industrial property. PG&E may grant exceptions if other suitable locations are not available.
- E. PG&E personnel have full access to inspect, read, or test metering facilities, whether the facilities are located indoors or outdoors. Applicants must ensure that all metering and service facilities are accessible and free of obstacles at all times when the metering equipment is energized. Applicants must maintain these accesses both **during** and **after** landscaping activities, fence installations, building construction, building renovation, remodeling activities, etc.

5.3.2. Prohibited Meter and Service Equipment Locations

The following locations are **not** acceptable for electric meters and service termination equipment.

- A. Locations deemed hazardous to either personnel or equipment, or locations found to be unsuitable for entry. These locations include:
1. Inside any residence.
 2. Directly over any stairway, ramp, or steps.
 3. Any area where personnel may contact either exposed, high-voltage conductors or equipment in motion.
 4. Any area that is accessible only through a trapdoor.
 5. Any elevator shaft.
 6. Any doorway, hatchway, or drive-through pathway designed for picking up goods through a window, where opening the meter panel blocks the through-area.
 7. Areas where entry may be restricted or controlled because of medical, health, environmental, or other safety-related issues.
 8. Any area in close proximity to a lake or water area. These locations are unsuitable when the meter faces the water.
- B. Underground vaults or enclosures.
- C. Areas where vibration, moisture, excessive temperature, fumes, or dust may damage the meter or interfere with its operation.
- D. Areas within or requiring access through any restroom, bathroom, shower, powder room, toilet, or private-type room.
- E. Portions of buildings where landscaping, fencing, or other construction activities will make the meter inaccessible.
- F. Inside garages for single-family residences.
- G. In a metallic cabinet (including doors), room, enclosure, or location that blocks or interferes with the radio frequency signal transmissions that are necessary for PG&E to operate its SmartMeter™ Advanced Meter Reading system. This applies only to meter panels that meet all of the following criteria.
- Single metered
 - Less than 400 amps continuous rating
 - Wall mounted
- H. In a room, utility closet, or area where metering facilities or termination enclosures are less than 3 feet away from any water source such as pipes, valves, fire sprinklers or equipment, or other wet facility.

5.3.3. Locating and Grouping Multiple Meters

When it is practical, PG&E will supply two or more meters from one service and will group the meters at one location. Also, see [Section 2](#), “Gas Service,” Subsection 2.3.5., “Multiple Buildings Located on One Lot,” on Page 2-15, and [Section 3](#), “Electric Service: Underground,” Subsection 3.2.5., “Installing Overhead and Underground Service for Two or More Buildings on One Lot,” on Page 3-4.

5.3.4. Electric Meter Rooms

Applicants must ensure that meter rooms meet the following requirements.

NOTE: Meter rooms may be used for communications equipment.

- A. Meter room specifications must be approved during the initial stages of construction. Submit drawings to your local project coordinator for the planner’s review and for review by the local meter shop.
- B. Designs must include a designated room for electric service, meters, and metering equipment.
- C. Meter rooms must be clear of obstructions and located inside of buildings on the ground floor or below the ground floor. High-rise buildings can have meter rooms above the ground floor.
- D. Meter rooms must have a doorway that opens 90 degrees or more to the outside of the building or into an area that is available to the public.
- E. Meter rooms must have a clear and safe working space as described in Subsection 5.4.4., “Working Space,” on Page 5-12, and Subsection 5.4.5., “Barricades,” on Page 5-15.
- F. Meter rooms must **not** include gas meters.
- G. Meter rooms may be locked if the applicant provides PG&E with independent access to the room. Consequently, the meter room must be locked in one of the following ways.
 - 1. Using a double-lock arrangement, provided by the applicant, with one lock for the applicant and one lock for PG&E.
 - 2. Using an acceptably located key box, provided and installed by PG&E, to hold the applicant’s key.
- H. Meter rooms must be identified by appropriately marking the doors or doorways as described in Subsection 5.5.1., “Properly Identifying and Marking Meters,” on Page 5-15.
- I. Meter rooms must have conduit(s) and pull tape installed as described in Subsection 5.2.1, “Applicant Responsibilities,” on Page 5-1 through Page 5-3.
- J. Designed and constructed with a means to adequately discharge any excess water that may enter the room from the conduit system.

5.4. Meter Heights, Clearances, Enclosures, and Protection

5.4.1. Meter Heights

A. Pole-, Pad-, and Wall-Mounted Meters

When installing meter enclosures on a pole, on a wall, or on a pad-mounted structure, applicants must ensure that the meters meet the following requirements, except when installing metering equipment on poles for communication services. In that situation, follow the requirements in 5.4.1.B. on Page 5-9. All metering and service-termination facility installations are subject to PG&E review and approval. The meter height must be measured to the horizontal centerline of the meter axis.

1. **PG&E's preferred meter height is 66 inches** for all individual service-termination and meter-panel installations. All electric meters must be located 75 inches maximum above the ground or standing surface. The minimum meter heights are listed below.
 - Meters installed in self-contained panels rated up to 320 amps must be a minimum of 48 inches.
 - Meters installed in outdoor transformer-rated panels 400 amps and above must be a minimum of 60 inches. This applies to wall-mounted and panel board construction.
2. When meters either are enclosed in a cabinet or installed indoors in a meter room, the **maximum** meter height is the same as for outdoor installations, or 75 inches. The **minimum** meter height must be 36 inches as measured from the ground or standing surface to the centerline of the meter.
3. For switchboard service with a current transformer (CT) compartment, the maximum meter height is 72-1/2 inches, as illustrated in [Section 10](#), Figure 10-25, "Standard Switchboard Service Section With CT Compartment and Filler Panel, 0 Volts Through 600 Volts," on Page 10-34. This applies both to indoor and outdoor installations.
4. In locations where snow accumulates, PG&E may require the minimum installed meter height to be increased. Specific meter-height requirements depend on the meter's location. Ask your local PG&E project coordinator to consult the electric meter department for specific meter-height requirements in snow-accumulation areas.

B. Pole-Mounted Communication Service and Meter Equipment

Applicants must ensure that communication service and meter equipment installed on PG&E or joint poles is placed so the bottom of the enclosure is a minimum of 7 feet to a maximum of 8 feet from the finished grade. If it is not possible to meet the height requirements, install a meter pedestal. Ask your PG&E project coordinator for [Numbered Document 027911](#), "Installation Details for Service to Pole-Mounted Communication Equipment," for specific requirements.

5.4.2. Meter Cabinet Enclosure Clearances

Applicants must ensure that meter cabinet enclosures are large enough to provide easy access to the meter and have an adequate working space for maintaining the meter. The cabinet requires a side-hinged door that can be latched open at 90° or more. Also, the enclosure and service equipment must comply with local code requirements. Detailed dimensional requirements are shown in Figure 5-1, “Meter Cabinet Enclosure Clearances,” and Table 5-1, “Meter Cabinet Enclosure Clearance Dimensions,” both below.

Applicants also must ensure that meter cabinet enclosures are maintained and work properly. In corrosive areas a fiberglass enclosure is recommended to help prevent deterioration of the metallic equipment.

Finally, applicants must ensure that when a cabinet enclosure is pad-mounted, a 3-foot clearance is maintained between the edge of the pad and the base of the pole.

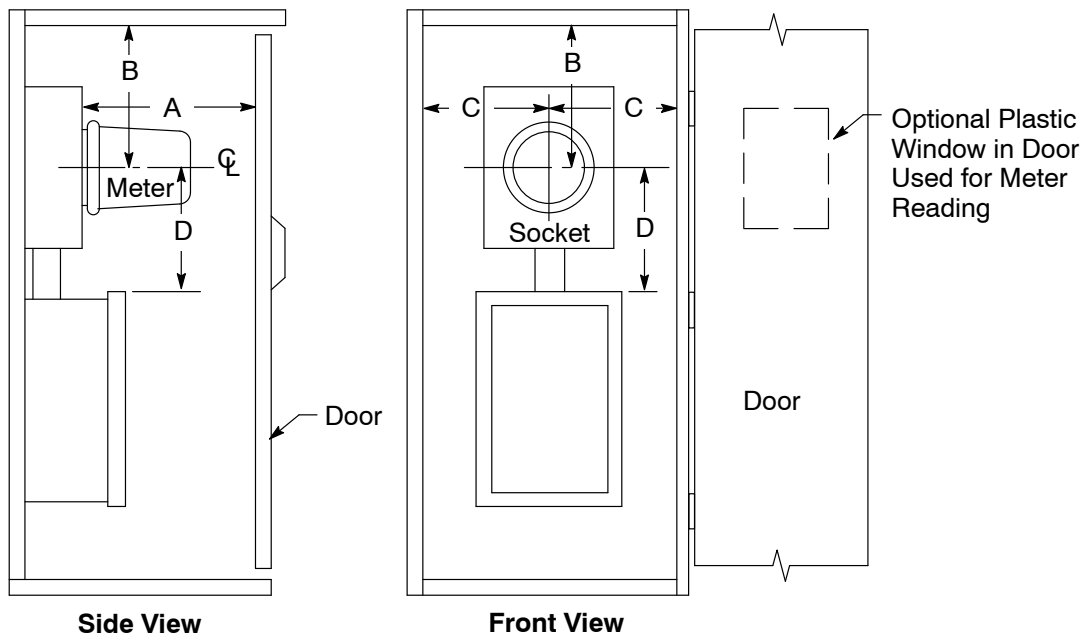

Figure 5-1
Meter Cabinet Enclosure Clearances

Table 5-1 Meter Cabinet Enclosure Clearance Dimensions

Dimension A	11-inch minimum / 15-inch maximum. See Note 1 below.
Dimension B	9-inch minimum to the edge of the access opening.
Dimension C	10-inch minimum to the edge of the access opening.
Dimension D	8-inch minimum from the meter centerline to the top of any protrusion below the meter or to the bottom of the enclosing cabinet.

1. The 11-inch minimum for Dimension A may be reduced to 8 inches only for residential, wall-mounted, meter cabinet enclosures.

5.4.3. Meter Set Clearance Requirements

Figure 5-2, “Electric and Gas Meter Set Separation Dimensions and Clearances,” found below, represent various metering facilities’ clearance requirements. If applicants install enclosures on their premises, the enclosures must meet the specifications provided in these illustrations.

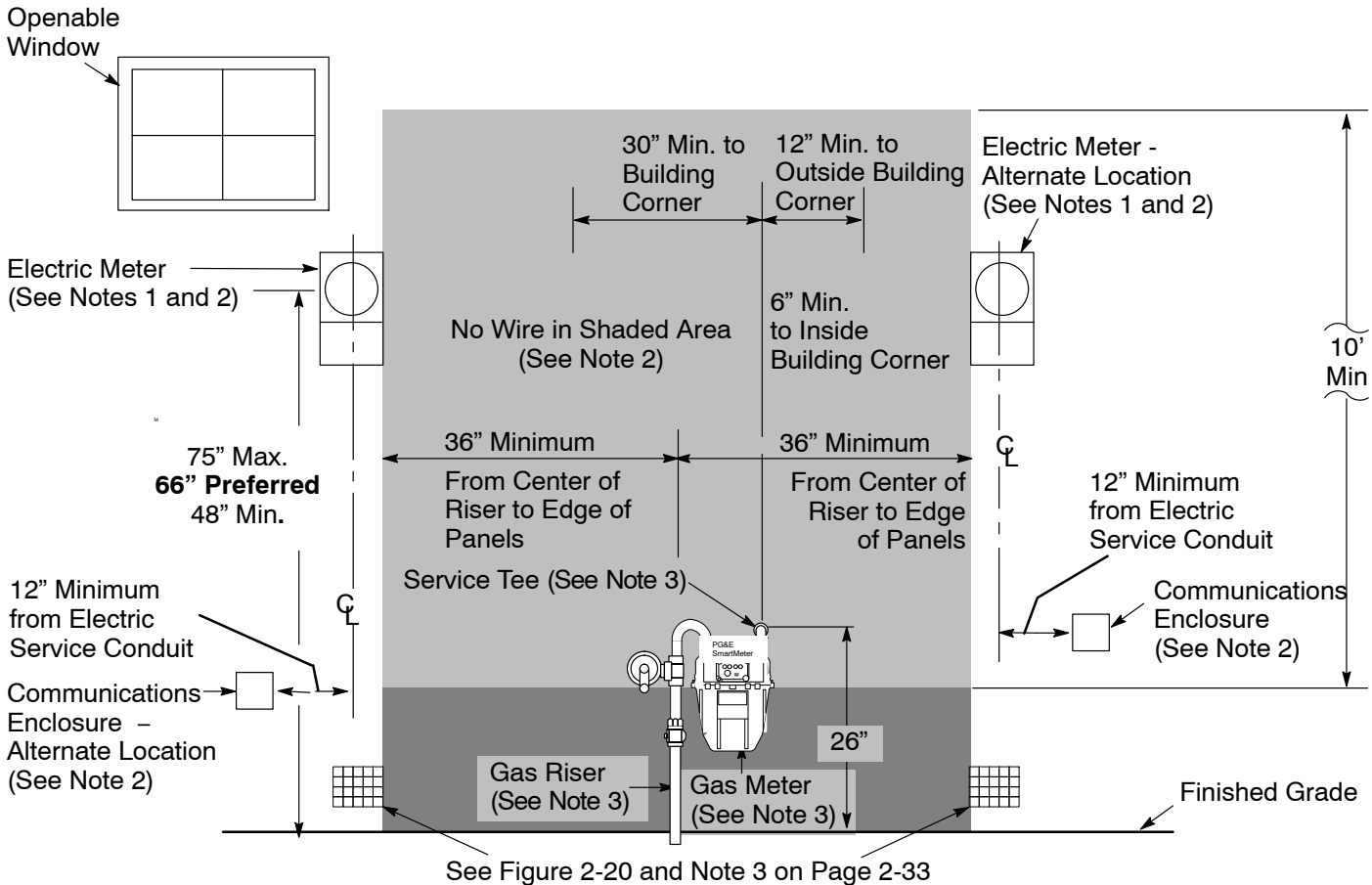

Figure 5-2
Electric and Gas Meter Set Separation Dimensions and Clearances

Notes in reference to Figure 5-2.

1. Electric meter-panel locations are subject to utility approval and must comply with the applicable code requirements. PG&E does **not** have specific requirements for the distance from the electric panel to the outside building corner. See [Section 5](#), “Electric Metering: General,” for properly locating the electric meters. See Subsection 5.4.4., “Working Space,” on Page 5-12, for electric meter working space.
2. Applicants must not install any electrical devices or equipment, including wires, cables, metering enclosures, and telecommunication enclosures, bond wires, clamps, or ground rods within the shaded area around the gas meter. The 36-inch distance can be reduced to 18 inches for electrical devices or equipment certified for NEC Class I, Division 2 locations.
3. See Figure 2-19, Notes 3 and 4, on Page 2-32, regarding gas facilities.
4. Applicants must not install water spigots, lines, gutter systems, or other sources of above-ground water to within 36 inches of the gas or electric facilities.

5.4.4. Working Space

Working space is defined as the whole area in front of the meter panel, the meter enclosure, the CT section, the service-conductor pulling or termination enclosure, or associated equipment. A working space permits access to the equipment and provides a safe working environment for personnel.

A working space must be located entirely on the applicant's property. Ask your local project coordinator to contact the PG&E electric meter department to review and approve of any exceptions to the Company's requirements for metering work spaces and locations.

The working space must be clear, level, and unobstructed at all times. See the descriptions below and the minimum required dimensions in Table 5-2 below.

In flood plains or other areas where elevated platforms are required in front of the meter, install permanent safety rails. The platform must be approved by the local metering department and meet specific PG&E requirements.

Wall-Mounted: For meter panels and service equipment the working space is **30 x 36 x 75 inches**. See Figure 5-3, "Semi-Flush Meter Installation," and Figure 5-4, "Enclosed Meter Installation," both on Page 5-13.

Floor-Standing (Pad-Mounted): For 600 volt switchboards, metering enclosures, and service termination equipment rated over 225 amps, the working space is **48 inches deep by 102 inches high**. For switchgear 601–25,000 volts, the working space depth is 96 inches. The width is the same dimensional width as the section. Measure the depth from the outside of the equipment's outer door. Concrete floors, housekeeping pads, and elevated platforms must extend out in front of the whole area to the minimum depth. See Figure 5-5 on Page 5-14 for additional requirements.

Table 5-2 Working Space Dimensional Requirements¹

Voltage (Volts)	Meter/Service Equipment Type	Dimensions (Inches)			Figure(s)
		Width	Depth	Height	
0–600	Wall-Mounted	30	36	75	5-3 & 5-4
	Wall-Mounted Inside Closet	See Note 2	36	75	NA
	Floor Standing (Pad-Mounted)	Same as enclosure section	48	102	5-5
601–25,000	Floor Standing (Pad-Mounted)	Same as enclosure section	96	102	5-5

¹ Pad-mounted meter pedestals up to 200 amps require a 30 x 36 x 75-inch work space.

² The width of the working space is the width of all metering equipment (connected or stacked) plus a minimum of 10 inches on the right and left sides. Closet doors must open a minimum 90 degrees and not reduce the working space in front of the metering equipment.

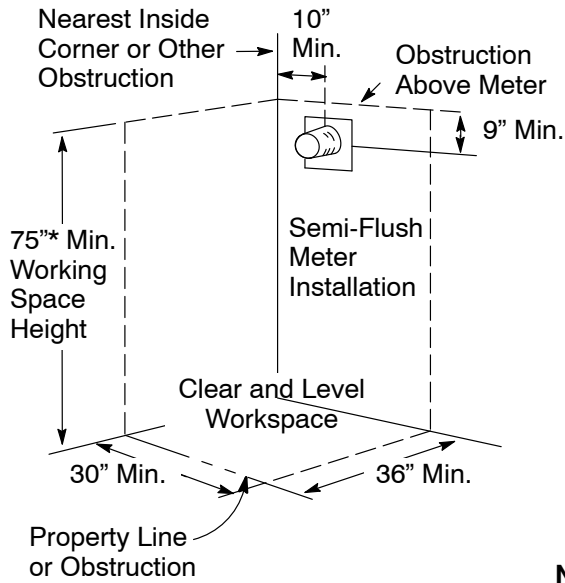

* 78" minimum for installations other than individual, field-installed meter panels. Increase the working-space height for installations greater than 66".

Figure 5-3
Semi-Flush Meter Installation

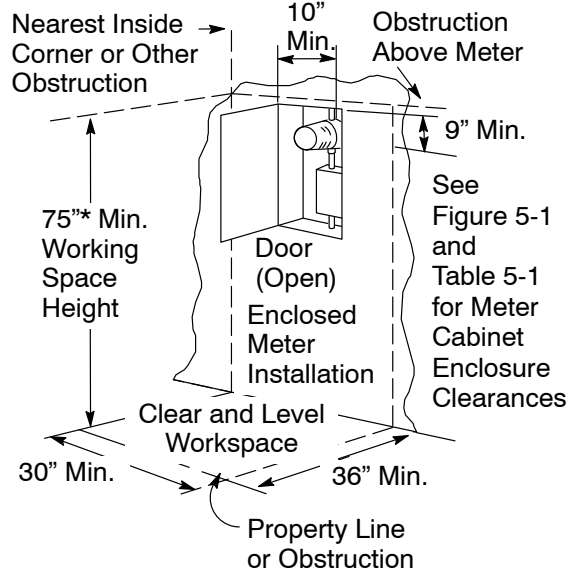

Note: To allow the cabinet door to open fully (90° or more), increase the 30" minimum-width dimension of the meter working space, as necessary.

Figure 5-4
Enclosed Meter Installation

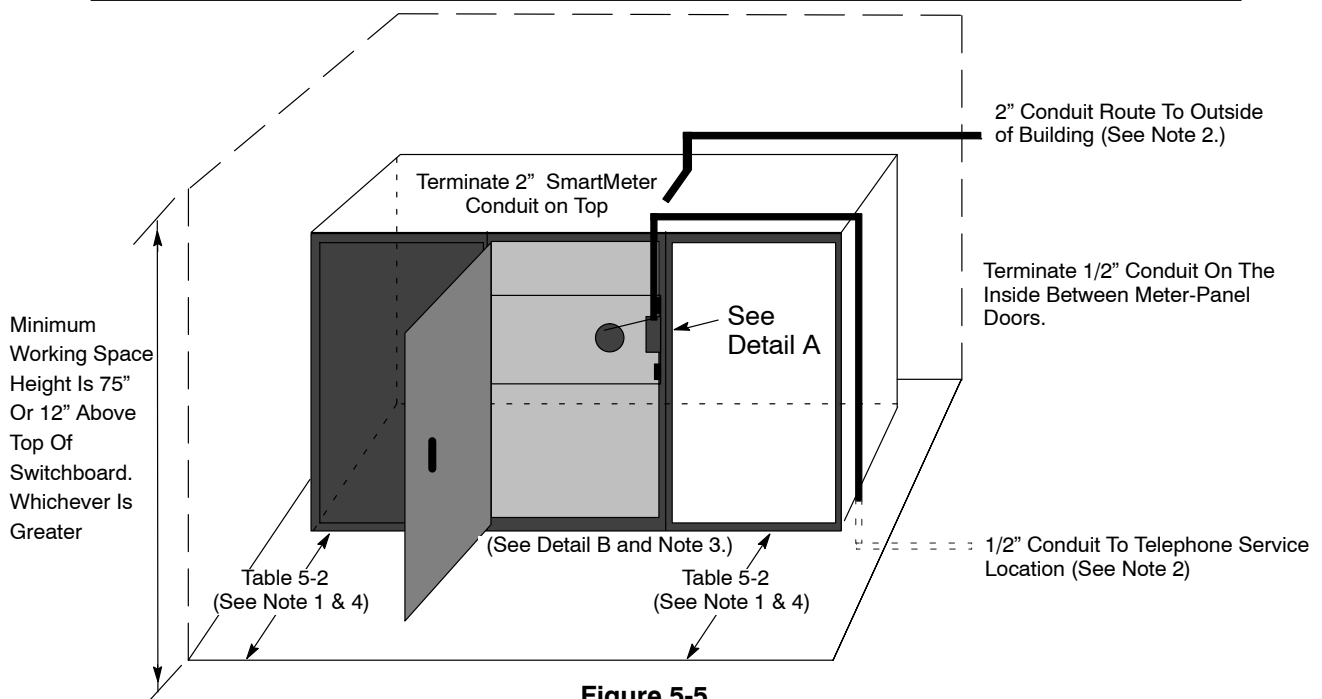
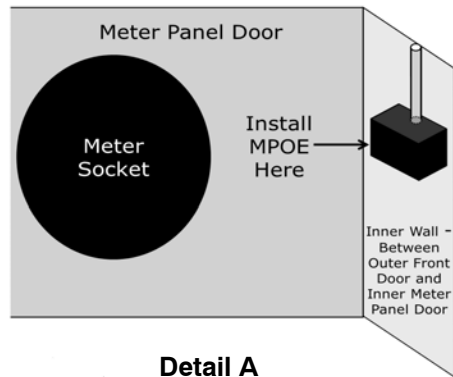
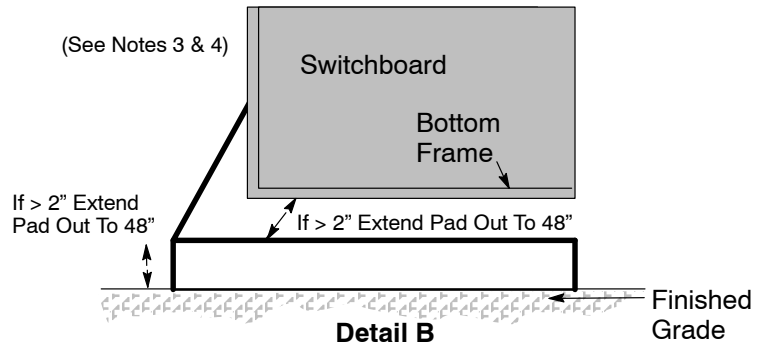

Figure 5-5
Preferred Location of Conduits for Indoor and Outdoor Meter Panels and Switchboards



Detail A



Detail B

Notes in reference to Figure 5-5.

1. A level, concrete structure (e.g., floor, pad) must extend out the minimum required distance in front of all sections to which PG&E requires access. This structure is used for floor-standing equipment (e.g., switchboard, termination enclosure). See Subsection 5.4.4., “Working Space,” on Page 5-12.
2. A 1/2-inch phone-line conduit may be required for all indoor and outdoor meter panels rated 500 kW or greater. See Item E. and Item F. in Subsection 5.2.3., “Applicant Responsibilities,” on Page 5-2. A 2-inch SmartMeter™ conduit is required only for indoor, wall-mounted or pad-mounted meter-panel enclosures of any size.
3. The switchboard’s bottom horizontal support frame must not protrude more than 3 inches above the floor or pad. This is in front of all PG&E sections (see Detail B).
4. The front edge of the switchboard must not be set back more that 2 inches either from the edge of a pad raised above ground or above the floor. This is for all PG&E sections.

5.4.5. Barricades

In some instances, a meter may be located in an area where the meter or working space is exposed to vehicles or hazardous conditions. In these cases, a permanent barricade outside of the working space is required. For vehicular traffic, applicants must ensure that a suitable barricade is erected.

A suitable barricade for vehicular traffic is concrete-filled steel pipes, 3 inches or greater in diameter, securely set in an adequate concrete pad for support. Also suitable for these conditions is a sleeve-mounted vehicle barricade where the sleeves are set in concrete.

Applicants also must ensure that suitable barricades are erected to protect personnel. A suitable barricade for this purpose is a heavy, wire-mesh fencing that is securely supported and is capable of protecting people from the hazards created by the moving parts of stationary machinery.

Contact your local PG&E inspector and project coordinator to determine if a barricade is required.

5.4.6. Meter Protection

Applicants must ensure that meters and metering equipment are enclosed in a protective cabinet in the following situations. Meter heights less than 36 inches are **not** allowed.

- A. For **all** installations, when the meter is less than 48 inches high, as measured from the horizontal centerline of the meter to the standing surface. Meter heights less than 36 inches are **not** allowed.
- B. When the meter is mounted on, or recessed in, any wall at a school or similar establishment and public safety is an issue.
- C. When environmental problems are anticipated.
- D. When corrosion problems are anticipated or present.
- E. When vandalism is anticipated.

Any protective structure surrounding meters and metering equipment must be pre-approved by the local meter shop and provide safe working conditions as determined by PG&E. Approval from the local authority having jurisdiction may also be required.

5.5. Meter Identification and Seals

5.5.1. Properly Identifying and Marking Meters

Where individual meters serve a remote location, or where meters are grouped at a common location (both residential and nonresidential), applicants must ensure that they mark sites and identify meters properly. Applicants must ensure that each individual meter position, its service disconnecting means, and the unit or dwelling being served is marked clearly and permanently. Three of the examples on the following page describe acceptable permanent markings and one describes unacceptable markings.

- A. **Preferred:** An identification plate attached by screws, rivets, or weatherproof adhesive.
- B. **Non-preferred but acceptable:** Paint that cannot be removed using common solvents. Apply the paint using a stencil.
- C. **Non-preferred but acceptable:** Manufactured decals that will not peel or fade due to environmental (e.g., sun, weather) conditions.
- D. **Unacceptable:** Tape-type and label-maker stick-on labels; hand-written lettering (sharpie, paint stick, etc.).

The identification must be legible. It must include a specific apartment number, a street number, use, or location. Ensure that the information is verified. A store name or other generic description may be included, but does **not** constitute acceptable identification when used alone. **For meters that serve pumps or other large equipment, the ampacity rating of the service disconnecting means (i.e., breakers, fuses) along with the type of equipment and the nameplate rating must also be marked.** PG&E will **not** install meters without a permanent address or location mark at each meter location.

When it is appropriate, applicants should include the area being served by the meter when permanently marking the site.

PG&E may make an **exception** to the rules for permanent marking when the Company is requested to set a meter for a single-family home that is under construction. In this case, PG&E will set the meter if the home's address is noted clearly and legibly either on the street side of the dwelling or on the lot in front of the dwelling. PG&E understands that during construction, the "permanent" address sometimes is not available when the dwelling is ready for the meter to be set.

5.5.2. Sealing Meters and Metering Equipment

PG&E seals all meters and enclosures for **utility** meters, metering equipment, and service-entrance equipment using PG&E's seals.

Applicants cannot locate or install equipment within meter sections, meter panels, switchboard sections, or equipment enclosures with existing PG&E seals unless they receive authorization from the PG&E electric meter group.

EXCEPTION: Equipment that provides access for replacing over-current protection fuses is exempted.

Only an authorized PG&E representative can break the PG&E seal.

Certified meter service providers (MSPs) also will seal all meters and enclosures for meters, metering equipment, and test-bypass switches owned by their respective companies with their companies' seals, as described in the [*DASMMMD in California*](#) (March 1999) document.

5.5.3. Locking Provisions

All transformer-rated and all three-phase installations must have provisions for sealing or locking all of the main service switches or breakers in a permanent (off) position. When installing service equipment of any phase or ampacity that contains multiple service (disconnect) switches, the applicant must ensure that provisions for locking each individual service (disconnect) switch are provided. The applicant must ensure that the locking mechanism is a permanent installation and that the clip, with a hole for the lock shaft, is made of a rigid metal. The breaker or switch covers can be nonmetallic. Finally, the applicant must ensure that these provisions are sealable and lockable with a padlock having a 5/16-inch lock shaft.

5.6. Meter Types and Connections

The following requirements refer specifically to meter types and connections. Applicants must follow the guidelines listed below.

- A. When installing a new service, ensure that the panel enclosures rated at 125 amps are Class 100 ampere services. Services and enclosures rated at 225 amps are Class 200 ampere services.
- B. Ensure that transformer-rated meters have a current rating of less than 100 amps (e.g., CL5, CL10, or CL20).
- C. Do **not** use K-based (i.e., bolt-in) meters when designing new installations. Services that need 400 amps (continuous) require current-transformer facilities.
- D. Ensure that sockets meet the requirements of [UL Standard UL-414](#), “Standard for Meter Sockets.”
- E. Locate potential taps, including the neutral connection, behind a sealed panel.
- F. Ensure that the meter manufacturer designs and fabricates transformer-rated meter sockets that are installed on hinged panels for back connection.

Applicants should use Table 5-3, “Meter Socket Requirements (Number of Jaws),” on Page 5-18, to find specific meter-socket requirements and to ensure they provide the proper equipment.

Table 5-3 Meter Socket Requirements (Number of Jaws)

Service			0–225 Amperes	226–320 Amperes ¹	400 Amperes and Above
Voltage	Phase	No. of Wires	Self-Contained	Self-Contained	Transformer Rated
120/240	1	3	4	4 ²	6
120/208 ³	1	3	5	—	—
120/208Y	3	4	7	—	13 or 15 ⁴
240 ⁵	3	3	5	5	8
120/240	3	4	7	—	13 or 15 ⁴
277/480Y	3	4	7	—	13 or 15 ⁴

- ¹ A socket-based, Class 320-ampere (continuous) meter will be installed on a Class 400 meter panel, rated at 80% continuous (i.e., 320 amps). Do **not** use Class 400, bolt-in meters on new installations. Service rated at 400 amps continuous requires current transformers to be installed.
- ² Only use a 4-jaw meter socket for a Class 320-ampere meter for single-phase residential applications.
- ³ In locations where PG&E maintains a 120/208-volt secondary system, 3-wire, single-phase service, typically the service is limited to what can be supplied by a main switch or service entrance rating of 225 amps. Single-phase loads that exceed the capacity of a 225-ampere main switch or service-entrance rating usually are supplied with a 120/208Y-volt, three-phase, 4-wire service.
- ⁴ The 15-jaw socket is acceptable, but not required.
- ⁵ Limited availability, at PG&E's discretion. **Not** for new installations.

Figure 5-6, “Connection Diagrams for Self-Contained Meter Sockets,” and Figure 5-7, “Connection Diagrams for Transformer-Rated Meter Sockets,” below, show the required connections for self-contained and transformer-rated meters.

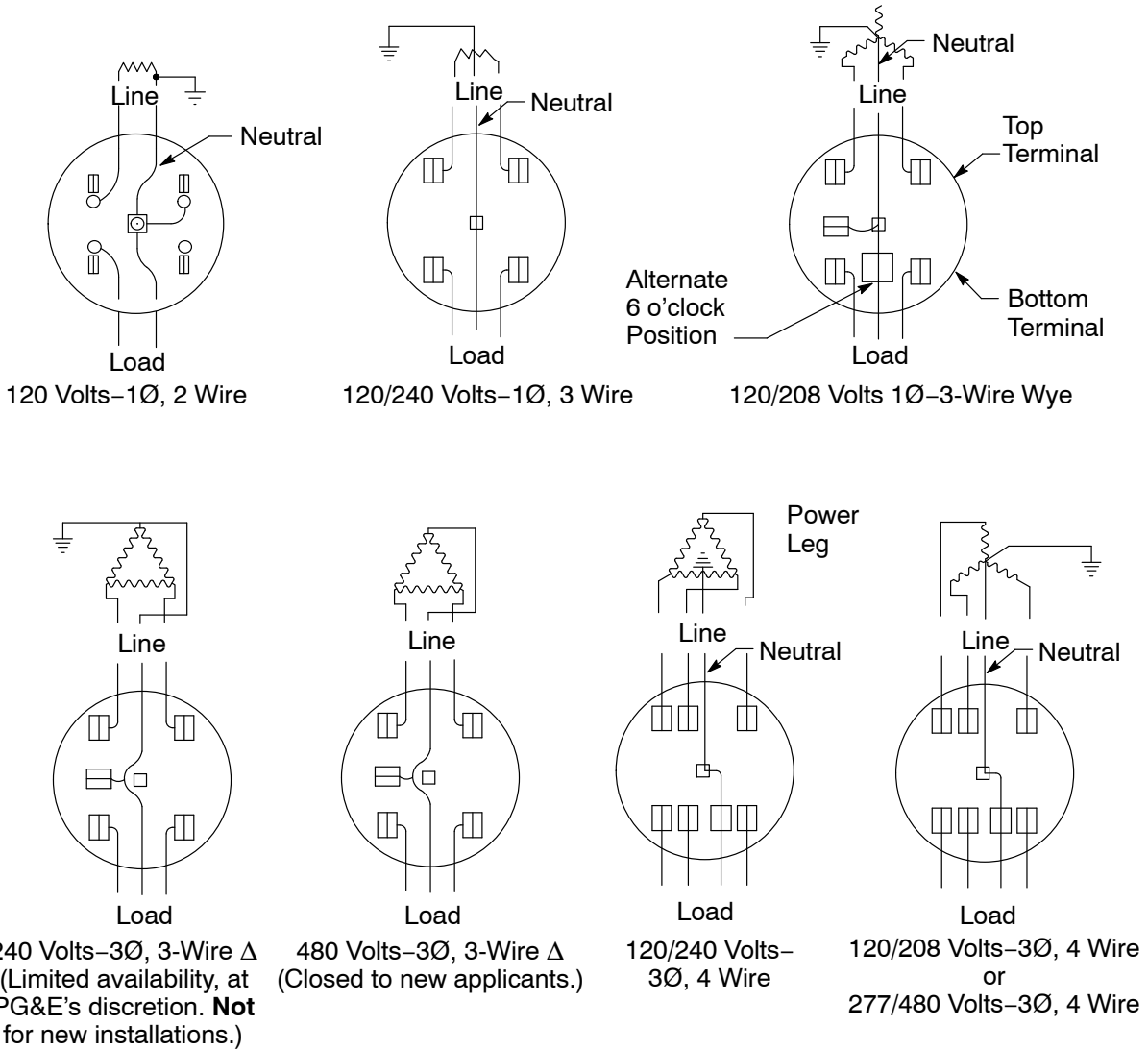

Front Views Shown

Figure 5-6
Connection Diagrams for Self-Contained Meter Sockets

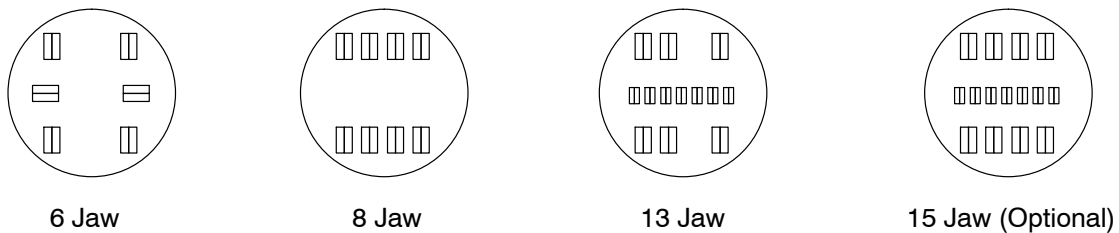

Figure 5-7
Connection Diagrams for Transformer-Rated Meter Sockets

NOTE: PG&E is responsible for wiring transformer-rated meter sockets.

5.6.1. Using a Meter Socket Adapter for Overhead-to-Underground Conversion

Applicants may use approved meter socket adapters to convert existing services. Do **not** use them to establish new service. For more information, see PG&E's [Numbered Document 061032](#), "Residential and Small Commercial Overhead to Underground Electric Service Conversion." Consult a PG&E project coordinator to determine which conversion method to use. The applicant must ensure that the meter socket adapter's grounding strap is connected to the grounded wire within the meter panel.

5.6.2. Installing Non-Allowed and Unauthorized Customer Equipment

Applicants must **not** install any type of meter-adapter, surge suppressor or protection device (e.g., TVSS), meter socket adapter, power usage or recording device, security or monitoring equipment, or similar interface device in, on, or between the electric revenue meter and meter sockets or inside any PG&E sealed section, including the instrument transformer (i.e., CT, PT) or service termination sections. These types of installations are not allowed and compromises the applicant's electric service. If safe to do so, PG&E personnel will remove any customer-owned devices and leave them on the applicant's premises if they are discovered.

Only PG&E-approved meter socket adapters used for overhead-to-underground conversions and residential solar (i.e., photo-voltaic) generation systems are exempt.

5.6.3. Fire-Pump Connections

PG&E allows the following types of service connections to fire-pump meter panels or switchboards. The requirements are described below.

- A. All fire-pump service connections must be approved by the local city, county, or state inspecting Authority Having Jurisdiction (AHJ). Site plans and equipment drawings must be submitted to PG&E for approval.
- B. **The service disconnect, meter panel, switchboard, or switchgear for the fire pump must be located in the same electrical room as the main service meter panel, switchboard or switchgear, and utility termination section.** They cannot be located in another room or building. When installed outdoors, the equipment must be located next to each other. They cannot be located in another room or building. When installed outdoors, the equipment must be located next to each other.
 1. For main switchboard (i.e., secondary) service equipment rated up to 600 volts, the following types of connections are allowed:
 - a. A fire-pump service tap installed from the utility termination section of the main switchboard to the fire-pump meter panel or switchboard. When fed from a PG&E underground service, the fire-pump service must be installed in rigid steel conduit and exit out of the top of the termination section or out of the upper sides, at least 12 inches above the terminating bus.

Do not place a fire-pump service tap in the termination section in either of the following two situations: (a) When the section is less than 90 inches high (see Figure 10-24, “Standard Switchboard Service Section With CT Compartment and Filler Panel, 0 Volts–600 Volts,” on Page 10-34); or (b) When the main switchboard is located below grade and has either a high side or back. (see Figure 10-15, “Switchboard Pull Section, High Entry,” on Page 10-26, for an illustration of the PG&E service entry).

- b. A fire-pump service connected in a dedicated tap section of the main switchboard.

If allowed, the local AHJ may require the tap section to be located away from the main breaker on the opposite side of the termination section.

- c. A fire-pump service connected to the load-side (i.e., after the main breaker) of the main switchboard.

- 2. For main switchgear (i.e., primary) service equipment rated between 601–25,000 volts, the following types of connections are allowed:

NOTE: Do not place fire-pump service taps or connections in the utility termination section of a primary switchgear.

- a. A fire-pump service connected in a dedicated tap section of the switchgear.
- b. A fire-pump service connected to the load-side (i.e., after the main breaker) of the main switchgear.

- 3. For main switchboard or switchgear service termination equipment rated between 0–25,000 volts, the following type of connection is allowed:

- a. A separate and dedicated utility service that is connected directly to the fire-pump meter panel, switchboard, or switchgear. This is usually referred to as a second PG&E service. (See Figure 5-8, “Fire-Pump Equipment Location and Service Connection Options,” on Page 5-22.)

- C. Proper access and signage is required for meter panels and switchboards serving fire pumps.
- D. Ensure that fire-pump wiring configurations, either 3-wire or 4-wire, are the same as the wiring configurations for the main switch.

Electric Service Termination and Meter Room

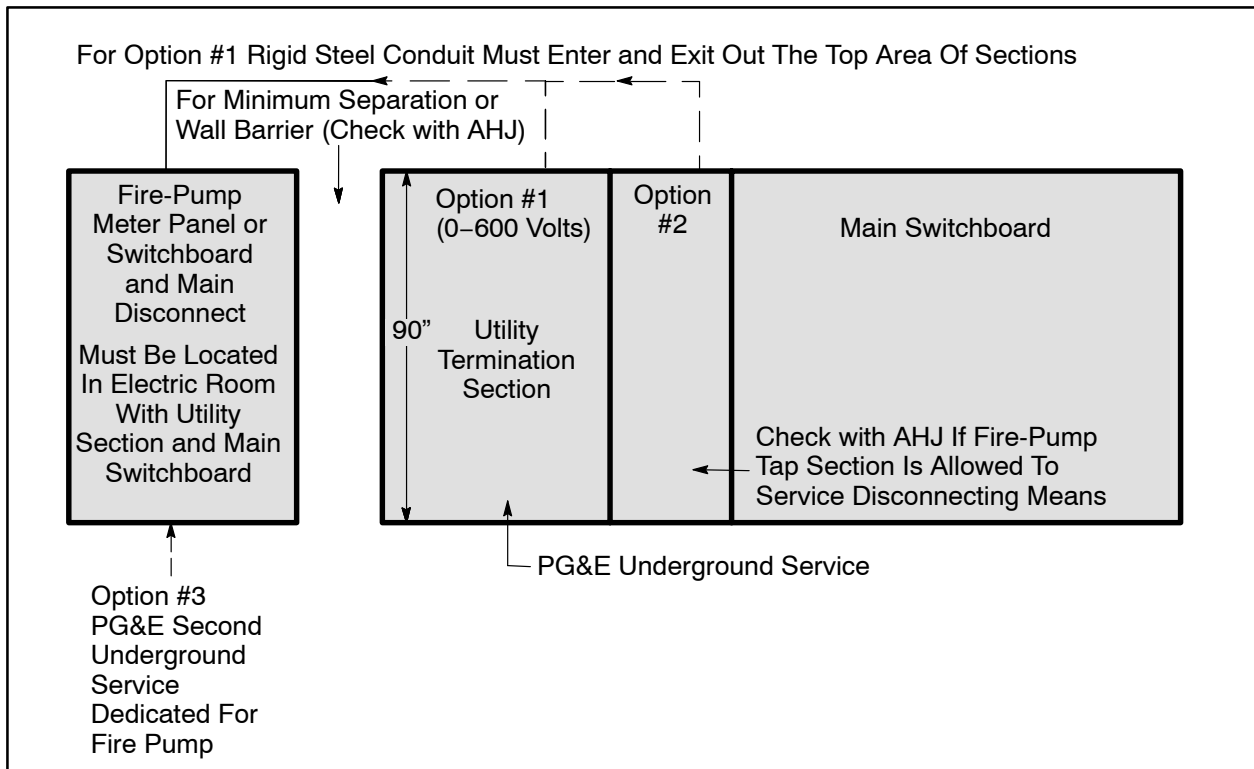

Figure 5-8
Fire-Pump Equipment Location and Service Connection Options

5.7. Main Service Disconnects and Switching Sequences

5.7.1. Main Service Disconnects

For each installed meter, the applicant, in compliance with applicable codes, must furnish and install a fusible switch, circuit breaker, or other approved disconnecting means for controlling all of (and **only**) the energy registered by that meter. When the governing code or ordinance permits, the disconnect means may consist of a group of fusible or circuit-breaker disconnects. PG&E requires access to these disconnects.

For transformer-rated metering equipment, applicants must place the main service disconnect switch adjacent to the meter. For self-contained metering equipment, the switch may be located inside or outside of the building being served, as described in the applicable electrical codes. When the switch is in another building or location, proper access, signage, and maps are required.

PG&E prefers applicants to have provisions for individual disconnects when they use switchboards with multimeter installations.

NOTE: See Paragraph B., in Subsection 1.14., "Determining the Service Rating," when more than one disconnecting means is installed.

5.7.2. Main Service Disconnect Switch Rated for Amperes Interrupting Capacity (AIC)

State and local codes require the service equipment's main disconnect switch and fuse, or the circuit breaker, to be rated at the available short-circuit current value.

PG&E designs its facilities so that the short-circuit duty at the service termination will not exceed 10,000-amps symmetrical for new, single-family, residential applicants that are supplied by an individual service drop or lateral that is rated at 225 amps or less. This service includes mobile homes and duplexes.

Typically, it is not feasible for PG&E to design its facilities to limit the short-circuit duty to 10,000 amps for other electrical services; for example, a 400-ampere, multimeter, residential or nonresidential installation. For these installations, on request, PG&E will provide the maximum available short-circuit current based on the service equipment's capacity. If the applicant increases the service equipment's capacity, the maximum-available short-circuit current may be higher.

5.7.3. Arc Flash Assessment

PG&E's electric system is dynamic and continually being reconfigured due to system needs and general maintenance. Therefore due to its many variables a range of impedance's should be considered in an arc flash assessment. To request an arc flash assessment contact your local project coordinator.

5.7.4. Electronic Trip Circuit Breakers

Electronic circuit breakers using a trip unit are programmable devices that measure the current flowing through the circuit breaker and initiate a trip signal, when appropriate. An electronic trip unit has multiple dials that can be adjusted to various settings. The IR setting is the continuous current value and must not exceed the ampacity rating of the enclosure. It is similar to the capacity or ampacity rating on thermal or thermal magnetic circuit breakers. The IR settings must be indicated on the trip unit. The IR settings typically are lettered and identified on a chart with the corresponding ampacity values. Electronic trip units are available with multiple ratings for each standard frame size.

The circuit breaker frame is the housing that contains the current-carrying and current-sensing components, along with the tripping and operating mechanism. The frame size (e.g., 800, 1,200, 1,600 amps) is the largest ampere rating available in a group of circuit breakers of similar physical configuration. Other types of breakers may have different frame sizes.

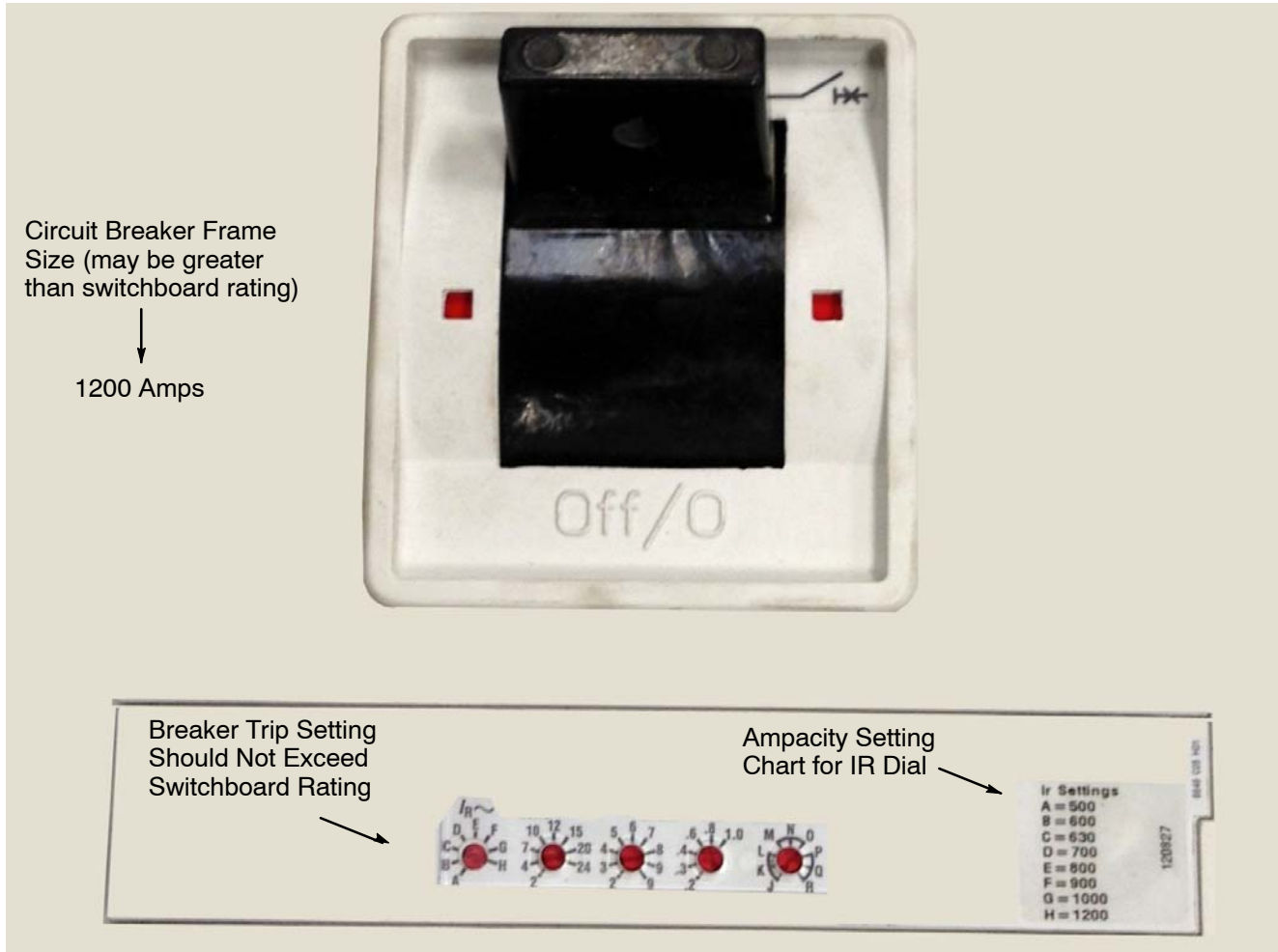

Figure 5-9
Circuit Breakers with Electronic Trip Unit

Notes in reference to Figure 5-9.

1. Match the letter on the IR dial to which the arrow head is pointing with the letter on the IR setting chart to determine the ampacity setting for the breaker.

5.7.5. Meter and Main Service Switch Sequence

PG&E places its meters and metering equipment ahead of (i.e., on the supply side of) the applicant's main service disconnecting means. Figure 5-10, "Single Meter With Main Service Switch," Figure 5-11, "Single Meter With Multiple Service Switches," and Figure 5-12, "Multimeter Disconnect Without Main Switch," below, all provide examples of this type of installation. Figure 5-14, "Multiple Remote Switchboard or Meter Panel Locations," on Page 5-26, also provides an example of meter and main service switch sequences for large projects with multiple meter rooms or buildings.

PG&E permits exceptions to this sequence only in circumstances where applying the electrical code requirements result in the applicant's main service disconnect means being installed ahead of PG&E's metering and metering equipment. Figure 5-13, "Multimeter Installation With Main Disconnect Switch," below, provides an example of this type of installation. In these instances, an individual disconnect switch also must be installed on the load side of each meter.

The local jurisdiction having authority for enforcing the electrical code requirements determines most of the requirements that applicants must follow when installing their means to disconnect. PG&E requires a main service disconnect for multimeter installations with more than six meters or individual service disconnects.

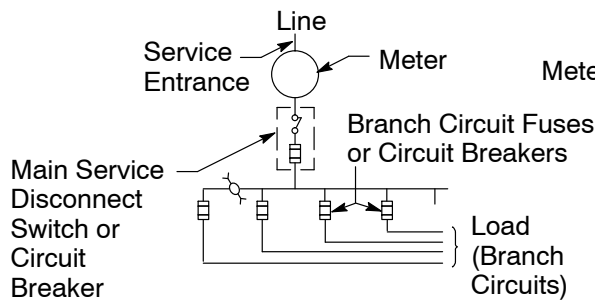

Figure 5-10
Single Meter With Main Service Switch

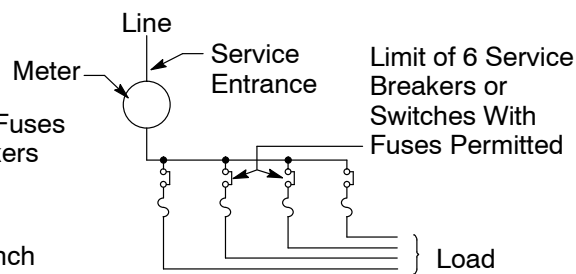

Figure 5-11
Single Meter With Multiple Service Switches

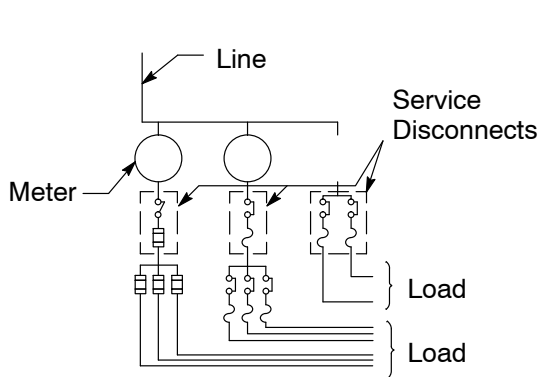

Figure 5-12
Multimeter Installation Without Main Disconnect Switch

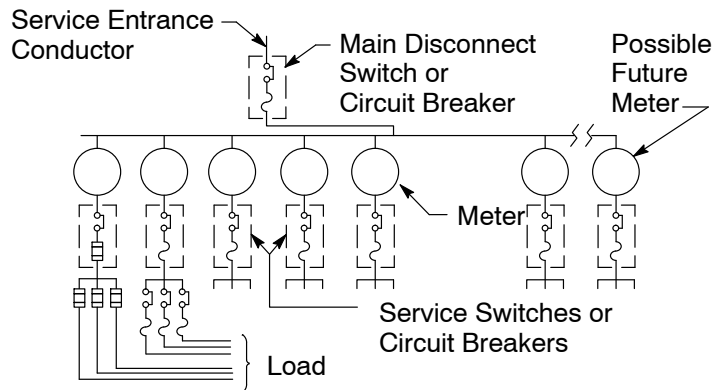

Figure 5-13
Multimeter Installation With Main Disconnect Switch

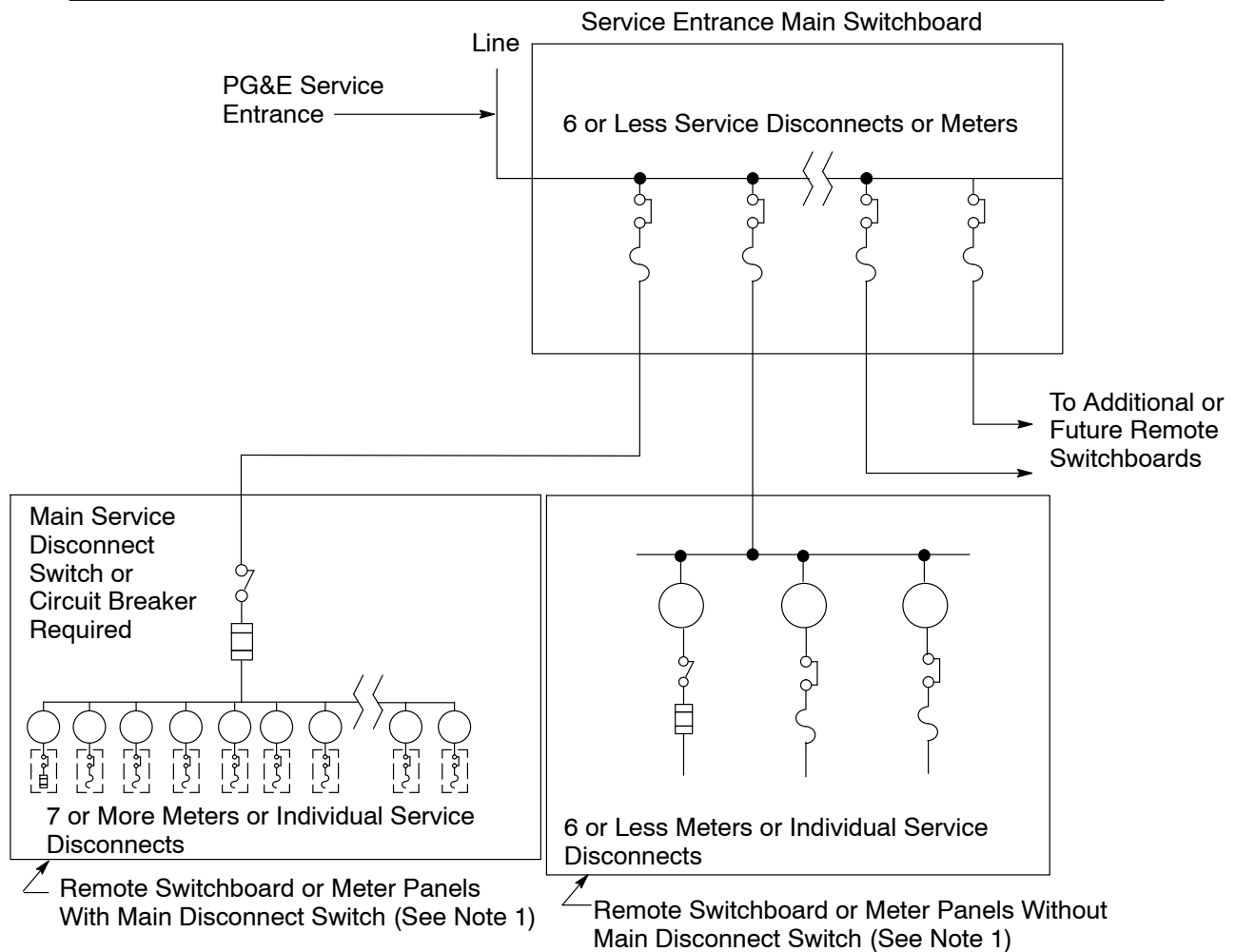

Figure 5-14
Multiple Remote Switchboard or Meter-Panel Locations

Notes in reference to Figure 5-14.

1. When a switchboard or meter panel is located in a different room, floor, or building from the main switchboard, it is considered remote.

5.8. Grounding

Applicants must bond and ground their electric services and metering equipment as required by applicable electrical codes, local ordinances, and PG&E requirements.

- A. Applicants must **not** use PG&E's gas facilities as part of the electrical grounding system.
 1. Do **not** install electrical devices or equipment, wires, cables, bonding or grounding wires, clamps, or ground rods around the gas meter set as shown in Figure 2-19 on Page 2-32 and Figure 2-22 on Page 2-35.
 2. Do **not** use PG&E's gas service piping, gas risers, or meter facilities for electric bonding or grounding that allows the gas meter, piping, or other gas facilities to become current-carrying conductors.

-
3. Do **not** allow gas pipe to be electrically bonded within meter enclosures, cabinets, or meter rooms.
 - B. PG&E supplies single-phase, 120/240-volt and 120/208-volt services and three-phase, 4-wire wye and delta services with a grounded service neutral conductor. When PG&E permits a three-phase, 3-wire, 240-volt service, one phase conductor must be grounded.
 - C. **Applicants must locate the terminations (e.g., ground bus) for their grounding electrode conductors outside of any section that PG&E seals.** Applicants must ensure that their terminations are designed to permit their grounding systems to be isolated, when necessary, from PG&E-supplied services. See “Notes in reference to Figure 5-15 and Figure 5-16,” on Page 5-28, specifically Note 2, which requires a continuous bond wire when grounding outside of the PG&E sealed section.
 - D. As mandated in the applicable sections of the electrical code, applicants may be required to physically protect their grounding electrode conductor against mechanical damage. PG&E prefers, but does not require, the grounding electrode conductor wire to be protected against physical damage by rigid steel conduit or armored cladding. Metal conduit must be bonded to an effective, grounded, fault-current path as described in the electrical code requirements.
 - E. Applicants must ensure that a grounded neutral connection, which is required for **safety** and metering purposes, exists in the PG&E-sealed section and is terminated in the same enclosure as the grounding electrode conductor.
 - F. When installing ground rods, applicants must only use approved ground rods and clamps as described in [Numbered Document 013109](#), “Corrosion Resistant Ground Rods and Ground Rod Clamps,” located in [Appendix C](#). For homes and buildings, an Ufer grounding system using rebar is an acceptable substitute to the ground-rod method. When ground rods are installed for concrete pads, refer to [Numbered Document 045292](#), “Concrete Pad for Three-Phase, Loop-Style, Pad-Mounted Transformers.” When ground rods are installed for equipment pads other than transformers (e.g., switchboards), install them according to their application. Finally, when installing ground rods in box pads, use [Numbered Document 064309](#), “Box-Pad for Pad-Mounted Transformers,” for installation information.
 - G. To ensure proper access to PG&E facilities during installation and maintenance, do not attach the bonding and grounding attachments for communication equipment on or near any PG&E sealed sections of the meter panel that would restrict access to the panel doors and meter.

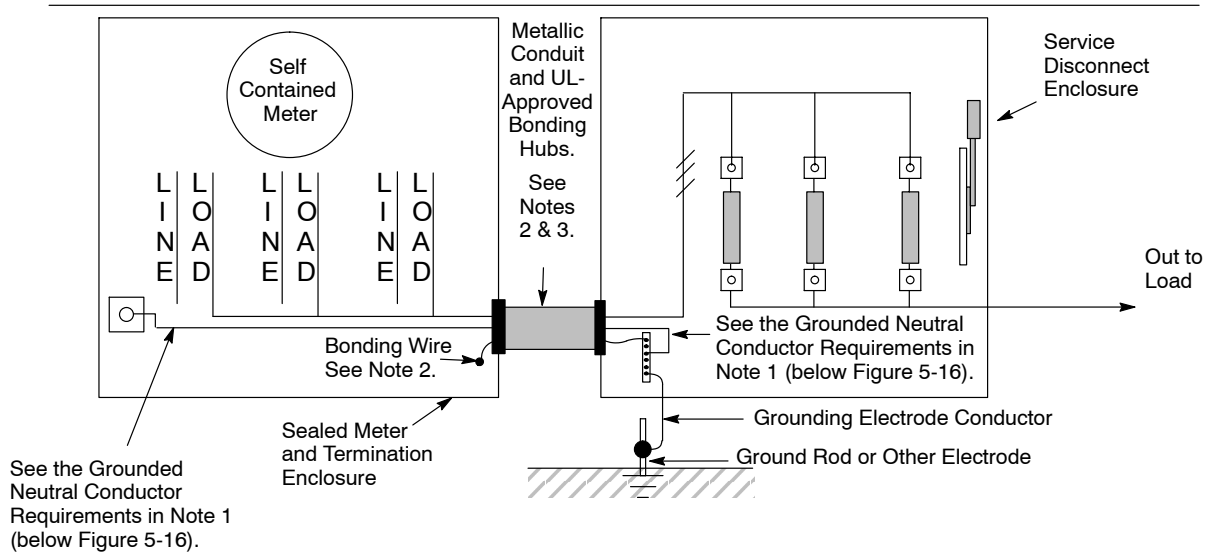

Figure 5-15
Grounding Outside of the Sealed Section—Self Contained Meter

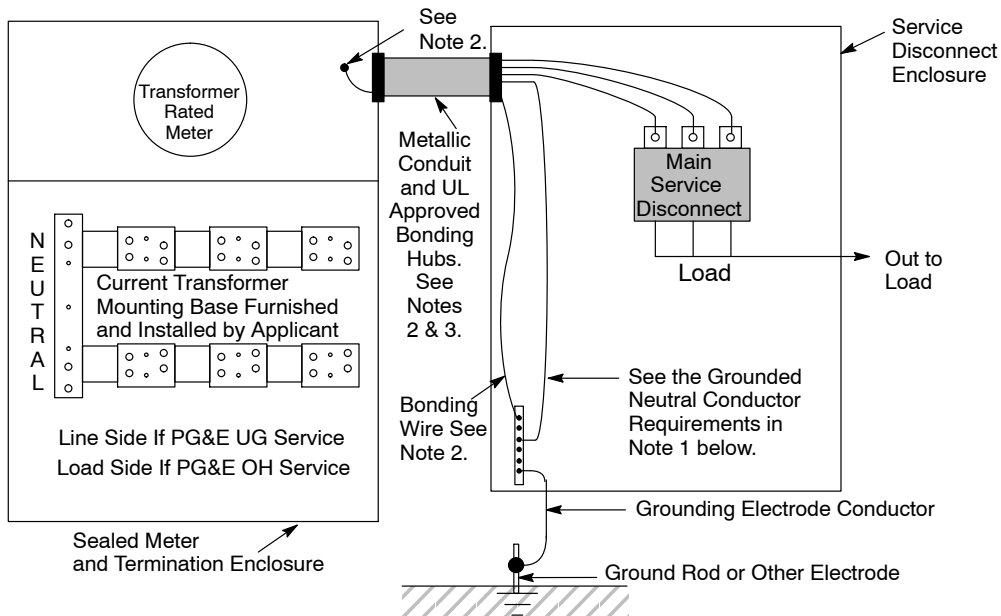

Figure 5-16
Grounding Outside of the Sealed Section—Transformer Rated Meter

Notes in reference to Figure 5-15 and Figure 5-16 are required for the safety of workers and the proper operation of PG&E facilities.

1. It is a requirement that the PG&E neutral conductor be grounded. This can be accomplished by terminating the neutral conductor to a grounded (i.e., non-insulated) neutral bus or to a ground bus in the service disconnect switch, as shown in Figure 5-15 and Figure 5-16. Or if provisions are available, terminate the neutral to a dedicated ground-rod and electrode conductor used solely for a meter panel more than 6 feet away.
2. An Equipment Grounding Conductor (EGC) is required between the PG&E service termination enclosure (e.g., meter panel) and the service disconnect enclosure. This is accomplished by attaching a bonding wire to the inside of the enclosures. A metallic conduit with Myers hub fittings that are U.L. certified for bonding also are required. The conduit and fittings must be approved by PG&E and the local authority having jurisdiction.
3. The metallic conduit diameter size must be equal to, or larger than, the diameter of the maximum knockout manufactured in the panel. The approved bonding hubs should not extend out past the edges of the meter panel.

5.9. Temporary Service

5.9.1. Temporary Service Using Permanent Service Panels

To lessen the potential for damage by staples and nails during the construction phase, applicants must use only **rigid metal conduit (RMC)** in locations where permanent service facilities will be installed and/or energized before completing the wall. The steel protects the conduit and/or cables from damage. Applicants also must protect their grounding conductors against mechanical damage by rigid steel conduit or armor cladding that runs from the main panel to a subterranean location and is embedded in concrete (e.g., garage). The service facilities and the wall must be a permanent and stable structure. If couplers are installed they must be of the same type (RMC) as the conduit. If transitioning from steel to rigid plastic the coupler must not reduce the internal diameter of the conduit. Refer to the steel and steel to plastic couplers in [Numbered Document 062288](#), “Underground Conduits,” located in [Appendix C](#). The service panel and facilities must meet all PG&E and local jurisdiction requirements. The service facilities must pass inspection by a PG&E inspector before being energized.

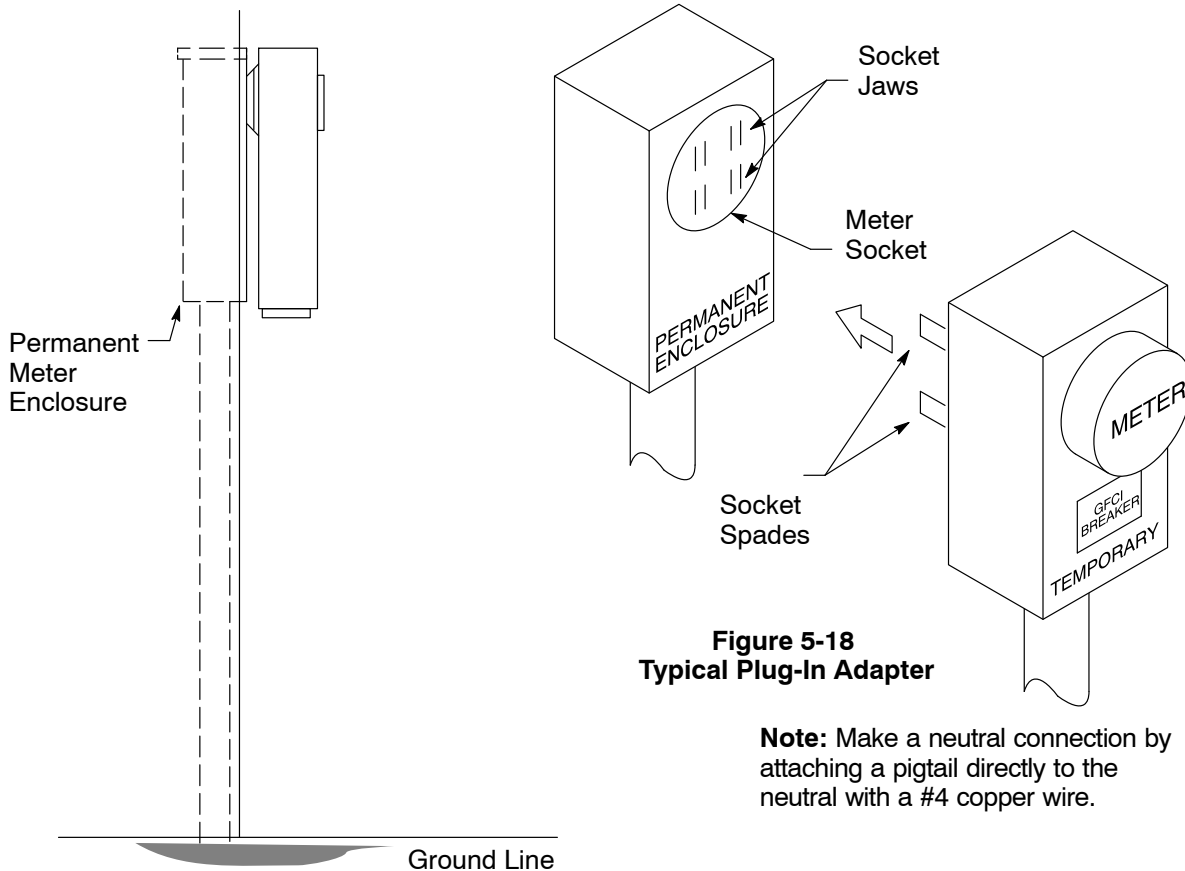

Figure 5-17
Plug-In Temporary Service

Figure 5-18
Typical Plug-In Adapter

Note: Make a neutral connection by attaching a pigtail directly to the neutral with a #4 copper wire.

5.9.2. Temporary-Service Metering Pedestal

Applicants must coordinate the connection of pedestal service conductors with PG&E project coordinators. **Before** installing temporary-service metering pedestals, applicants must obtain any inspections and permits that are required from the local authority having jurisdiction.

Applicants must install temporary-service metering pedestals as shown in Figure 5-19, “Temporary-Service Metering Pedestal,” below.

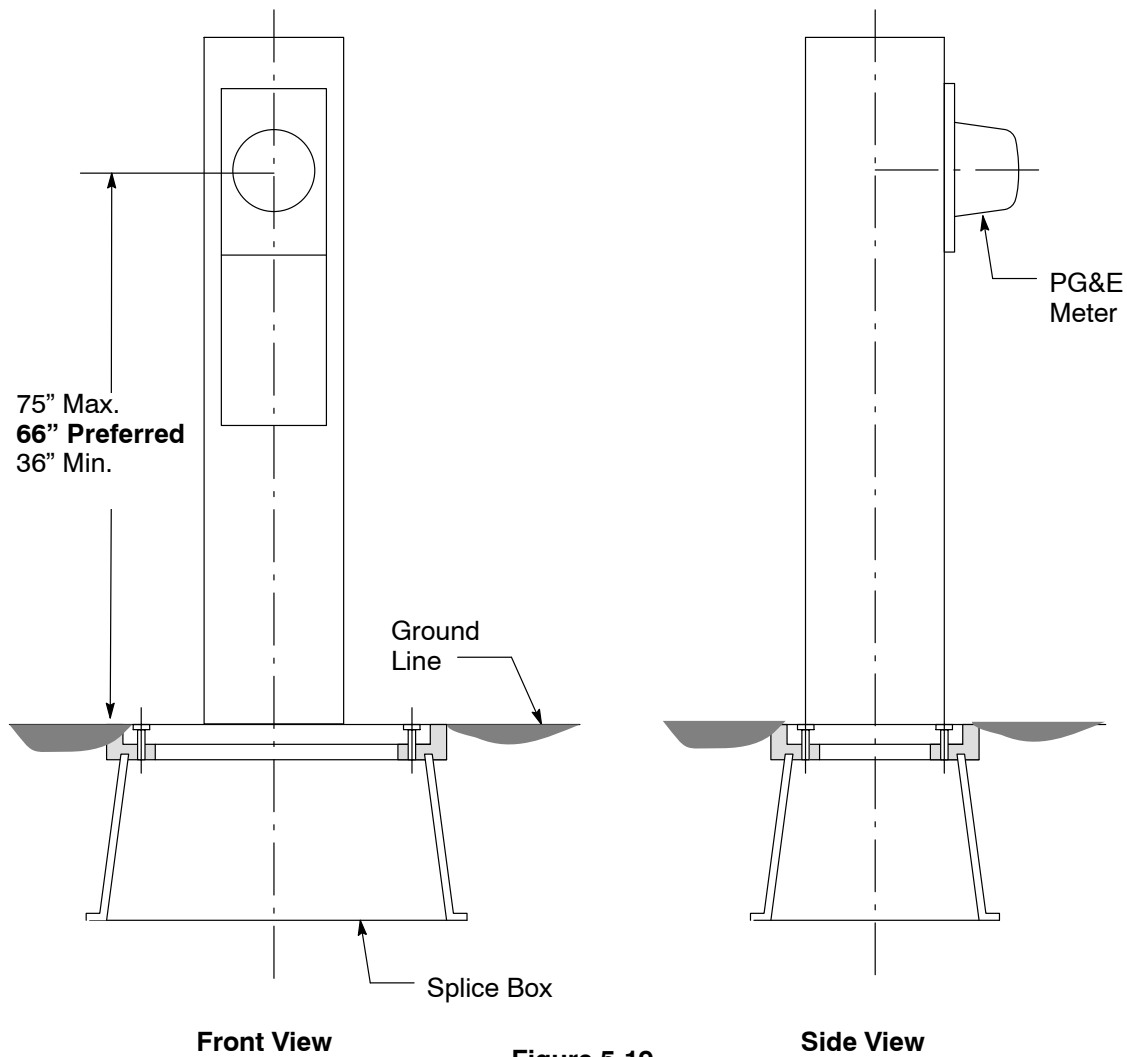

Figure 5-19
Temporary-Service Metering Pedestal

5.9.3. Temporary Plug-In Service

The local inspection authority having jurisdiction must approve all of the permanent service connections to the main service disconnect **before** an applicant installs a temporary service adapter. Additionally, the local authority having jurisdiction must approve the applicant's plan for installing and using temporary service adapters.

Applicants must install temporary plug-in service as shown in Figure 5-17, "Plug-In Temporary Service," and Figure 5-18, "Typical Plug-In Adapter," both on Page 5-29.

5.10. Connecting Non-Utility Power Sources to Utility Services

By enacting *California Health and Safety Code*, Division 104, "Environmental Health," Part 15, "Miscellaneous Requirements," Chapter 5, "Electrical Hazards," [Sections 119075 through 119090](#), the legislature of the state of California intended to prevent electricity generated by permanent or portable electric generators from backfeeding into a utility's electrical distribution system. In addition, [California Code of Regulations \(CCR\) Title 8, Section 2320.9](#), "Backfeeding or Interconnection," says that electrical power sources, both permanent and temporary, can **not** be connected to a premises' wiring system, or parts of such a system, unless positive means are used to prevent electricity from being transmitted beyond the premises' wiring system, or beyond any intentionally segregated parts of such a system.

EXCEPTION: The service utility can authorize an interconnection.

A **positive means** is defined in this *CCR* subpart as a device that, when used or operated, interrupts or prevents the flow of current to or from the electrical system. Also, a positive means provides the device operator or user with a visual or definite indication of the existing condition or state of the electrical system.

Before installing an applicant-owned and operated generator that may or may not operate in parallel with PG&E's system, the applicant must contact a local PG&E project coordinator for the interconnection requirements specific to the location where it will be used. PG&E's Electric Generation Interconnection (EGI) department may be reached by email at gen@pge.com, or leave a message on their hotline at 415-972-5676. Also, for interconnection requirements, applicants should refer to PG&E's [Distribution Interconnection Handbook](#), which is available on PG&E's Internet website at <http://www.pge.com/mybusiness/customerservice/nonpgeutility/generateownpower/distributedgeneration/interconnectionhandbook/index.shtml>.

NOTE: See [Numbered Document 060559](#), "Disconnect Switch Requirements For Distributed Generation Customers," located in [Appendix C](#), when customer generation systems are installed on their premises.

5.10.1. Specific Interconnection Requirements for Services Up to 600 Volts

Residential and small commercial applicants with generating facilities on their premises who want to take advantage of PG&E's standard net energy metering (NEM) program must meet the following requirements.

A. Requirements for Small Power Generators (Qualifying Facilities) and Co-Generation Interconnections Including NEM Interconnection Installations

Table 5-4, "Requirements For AC Disconnect Switches," on Page 5-32, shows the requirements for an alternating current (ac) disconnect.

Table 5-4 Requirements For AC Disconnect Switches

Inverter-Based Generators	Phase(s)	AC Disconnect Required?
Self-Contained Meter Panel, Socket-Based, 320 Amps or Less (Continuous Current Rating) ¹	Single	No ²
All Other Self-Contained or Transformer-Rated Meter Panels	All	Yes
Non-Inverter-Based Generators	Phase(s)	AC Disconnect Required?
All Self-Contained and Transformer-Rated Meter Panels	All	Yes

¹ An ac disconnect is required for all K-base meter panels of any ampacity rating.

² If an ac disconnect switch is installed, it must be PG&E approved.

A fusible ac disconnect switch is required for generator interconnections ahead of the main breaker (line/supply side connection) and after the meter. A nonfusible ac disconnect switch may be installed if the generation is connected to a dedicated, alternative generation breaker that came manufactured (e.g., solar ready) with the meter panel. For specific requirements, refer to [PG&E Bulletin TD-6999B-048](#), "Requirements for Line Side Interconnections for Distributed Generation," located in [Appendix B](#).

As specified in [Electric Rule 21](#), "Generating Facility Interconnections," and as required by PG&E, the generating facility must have an ac disconnect switch that meets the requirements described in [Numbered Document 060559](#) and listed below.

- Easily accessible by PG&E, when requested.
- Manually and gang operated. Lockable in the "open" position.
- Allows visible verification that an air-gap of separation has occurred.
- Located 10 feet or less from PG&E's electric meter at the point of common coupling or interconnection and is seen easily, in line of sight, from the panel.

- Permanent, approved sign(s) attached at PG&E’s electric revenue meter’s point of common coupling. A map showing the location of the ac disconnect switch also may be required.
- Installed in a safe and acceptable location that meets the same location, height, and working space requirements as a meter panel. The height is measured from the ground to the top of the switch.

For additional information on disconnect switches and distributed generation requirements, see the PG&E [Distribution Interconnection Handbook](#).

B. Virtual Net Energy Metering – VNEM (NEMV)

This program allows qualified participants to install a single solar system to cover the electricity load of both common and tenant metered areas connected at the same service delivery point.

This “[Electric Schedules](#)” table helps housing owners allocate a solar system’s electricity to tenants enabling residents to receive the direct benefits of the building’s solar system without requiring the generator to be physically connected to each billing meters.

Refer to [PG&E Bulletin TD-6999B-005](#), “Virtual Net Energy Metering Installations,” included in [Appendix B](#), which explains the requirements for VNEM installations and illustrates the various metering and connection options for VNEM projects. Check the PG&E [Electric Schedules](#) website for the latest information on this program.

C. Requirements for Generators That Are *Not* Permanently Connected (i.e., Temporary Connections)

Portable electric generators must be connected as described in the *California Health and Safety Code*, Division 104, Part 15, Chapter 5, [Section 119075\(b\)](#). This code says that any portable electric generator that can be connected temporarily to an applicant’s electrical system, and that is supplied typically by an electrical corporation or state or local public agency, can be connected only after separating the applicant’s electrical system from that of the electrical corporation or state or local agency.

This rule applies to any generator connected as a temporary (i.e., nonroutine, nonscheduled) or emergency source of power.

Connect any portable electric generator that is used periodically as a source of power, either on an as-needed or scheduled basis, as described in Subsection 5.10.1.D., below. An example would be a generator used to provide backup power for equipment maintenance.

D. Requirements for Generators That Are Connected Either Permanently or Periodically to an Electrical Service and Used on a Planned, Routine, or Scheduled Basis, but Do *Not* Operate in Parallel with the PG&E System.

Generators falling under this category must have a disconnect switch that is accessible to, and in a location approved by, the serving utility.



Generator

These generators must be connected as described in PG&E's [Electric Rule 2](#), "Description of Service," Item E.6, and in the *California Health and Safety Code*, Division 104, Part 15, Chapter 5, [Section 119075\(c\)](#). These rules state that any electrical generator that can be permanently connected to an applicant's electrical system must be connected only by means of a **double throw switch** (see Figure 5-20 on Page 5-34). This switch isolates the applicant's electrical system from that of the electrical corporation or state or local agency.

EXCEPTION: Generators that are designed to run in parallel with the servicing utility's system, and that are approved by that utility, are exempt from these rules.

The double throw switch may be either a manual or automatic transfer switch meeting the requirements of [UL Standard 1008](#), "Transfer Switch Equipment." The switch may be an integral part either of the generator assembly or of the service facilities, and must be approved by the authorities having jurisdiction.

Please visit "[Electric Generator Safety](http://www.pge.com/generator/)" (<http://www.pge.com/generator/>) for more information. (From [PG&E's home page](#), click "For My Home," then from the "Education & Safety" drop-down box, click on "Gas & Electric Safety." On the left side of the page, click "Electric Generator Safety.")

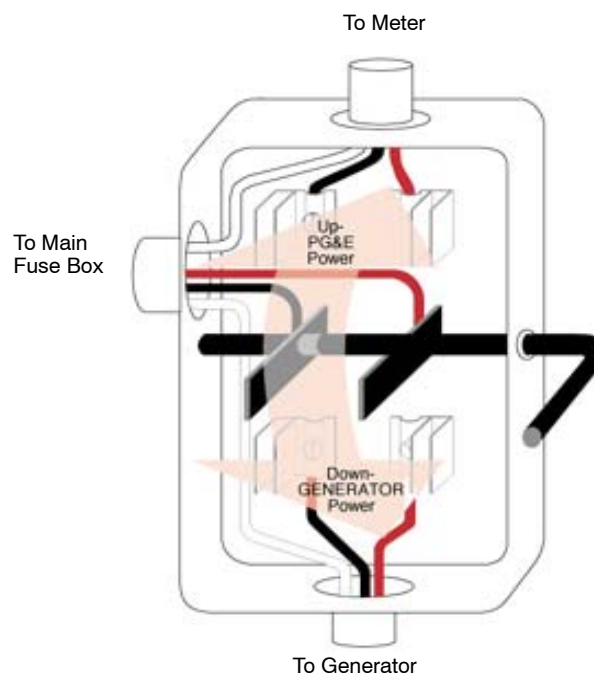

Figure 5-20
Transfer Switch

NOTE: Ensure that the transfer switch is installed after the meter panel on the customer's side, not before the meter panel on the PG&E side.

E. Requirements for NEM Revenue Metering With a 4-Wire System at the Point of Common Coupling

NEM revenue metering that has a 4-wire system at the point of common coupling also must have a NEM meter panel configured for a 4-wire system (three phases and a neutral).

When the normal source of voltage supplying PG&E co-generation metering potentially can be interrupted, PG&E, at its option, may install metering with an auxiliary source of power at the applicant's expense.

F. Requirements for Generators Powering 10 kW (or Less), Stand-Alone, Field-Installed Telecommunication Facilities and Special Applications

Applicants can own 10 kW (or less) generators used for stand-alone, field-installed, telecommunication facilities and special applications. However, PG&E field personnel perform maintenance and routine testing on electric supply and meter facilities, and must be able to perform these functions even when applicants are unable to be present. Therefore, applicants must provide a positive means to prevent their generators from backfeeding into the utility system. This requires installing special equipment, as described in the PG&E [Distribution Interconnection Handbook](#).

Usually, these equipment installations are performed in the field. The generator or alternate power source either is integrated with or is made a part of stand-alone equipment and metering facilities. For example, an applicant could install a double throw switch to isolate his or her equipment and power supply and prevent electricity from flowing into the electric metering and supply system.

5.10.2. Warning Statements and Labels for Interconnected Services

California Health and Safety Code, Division 104, Part 15, Chapter 5, [Section 119080\(a\)](#), requires that every manufacturer of a portable or permanent electrical generator that is capable of being connected either permanently or temporarily to a commercial, industrial, or residential structure's electrical system include a warning statement.

The warning statement must be published in the generator's instruction manual and a legible warning label must be present on the generator. The warning statement must contain the requirement of *California Health and Safety Code*, Division 104, Part 15, Chapter 5, [Section 119075](#), and explain potential electrical hazards that backfeed can create when it flows into a utility's distribution system.

The same warning information must be included in all advertisements offering portable electrical generators.

California Health and Safety Code, Division 104, Part 15, Chapter 5, [Section 1190809\(b\)](#), also requires that portable electrical generators display a legible warning label on a visible surface of the generator. It goes on to say that individuals or public agencies can **not** sell or rent to another person or public agency, or offer for sale or rent to another person or public agency, a portable generator that does not have a warning labeled displayed on the equipment.

5.10.3. Violation

California Health and Safety Code, Division 104, Part 15, Chapter 5, [Section 119090](#), states that violating the requirements of [Section 119075 through Section 119085](#) is a misdemeanor offense, subject to a fine of not more than \$500.00 or not more than 6 months imprisonment.

5.11. Plug-In Electric Vehicle Interconnections

Residential customers with Plug-In Electric Vehicles (PEVs) can connect the Electric Vehicle Supply Equipment (EVSE) to their residences under PG&E's existing "[Electric Schedules,](#)" [PG&E Bulletin TD-7001B-002](#), "PG&E Standards and Requirements for Plug-In Electric Vehicle Interconnections," included in [Appendix B](#), explains the requirements for installing PEV supply equipment and illustrates the various metering and connection options to serve PEVs.

Additional PEV information can be found in PG&E's [Plug-in Electric Vehicles](#) website at <http://www.pge.com/electricvehicles/>. For questions regarding PG&E's PEV requirements, please contact the [Building and Renovation Service Center \(BRSC\)](#) at 877-743-7782.

**SECTION 6
ELECTRIC METERING:
RESIDENTIAL**

SECTION 6 ELECTRIC METERING: RESIDENTIAL

Section 6 Electric Metering: Residential

6.1. Scope

This section of the manual provides the Pacific Gas and Electric Company (PG&E/the Company) service specifications and requirements for residential electric metering. Also, it describes the required locations for those residential meters. This section includes specific information that is **not** covered by the basic requirements in [Section 5](#), “Electric Metering: General.”

6.2. Residential Electric Service: Specifications and Requirements

PG&E typically provides electricity for residential and commercial applicants served on a domestic rate schedule with 3-wire, 120/240-volt, single-phase, 60-hertz (Hz), alternating current (ac) service. However, the Company is able to supply 3-wire, 120/208-volt, single-phase, 60 Hz, ac service at some locations. **This service is limited to a service-entrance rating of 225 amperes (amps).** Applicants should contact their local PG&E project coordinators and ask about the type of services that are available for their specific locations.

NOTE: See [Table FM-1, “Service Planning Office Contact Information.”](#) at the front of this manual starting on Page iv, for specific contact numbers listed by area.

6.2.1. Service Classes

The 125-amp-rated panels are classified as Class 100. The 225-amp-rated panels are classified as Class 200.

6.2.2. Test-Bypass Facilities

For single-phase residential installations, test-bypass facilities may be provided, but are not required. However, test-bypass facilities **are** required for the following installations.

- Single-family residential Service Class 320 meter, or residential meter panels that are larger than 225 amp, 120/240 volt, single phase, 3-wire.
- Residential meter panels of any size or phase that supply power to elevators.
- All common and tenant area meter panels of any size or phase, at multi-residential and live-work buildings with 2 to 5 units, that supply power to fire alarms or equipment, security alarms, laundry rooms, or significant interior lighting. Significant interior lighting is for hallways, storage rooms or areas, and garage areas.
- All common and tenant area meters at multi-residential and live-work buildings with 6 or more units.

6.3. Residential Electric Metering Pedestals

Residential electric meter pedestals, as shown in Figure 6-1, “Residential Electric Metering Pedestal,” below, must have a minimum rating of 100 amps and a maximum rating of 200 amps. The pedestal also must meet the requirements specified in the [Electric Utility Service Equipment Requirements Committee \(EUSERC\)](#) manual, Drawing 307.

For authorization to attach telephone and cable television terminating facilities to the post, contact your local PG&E project coordinators.

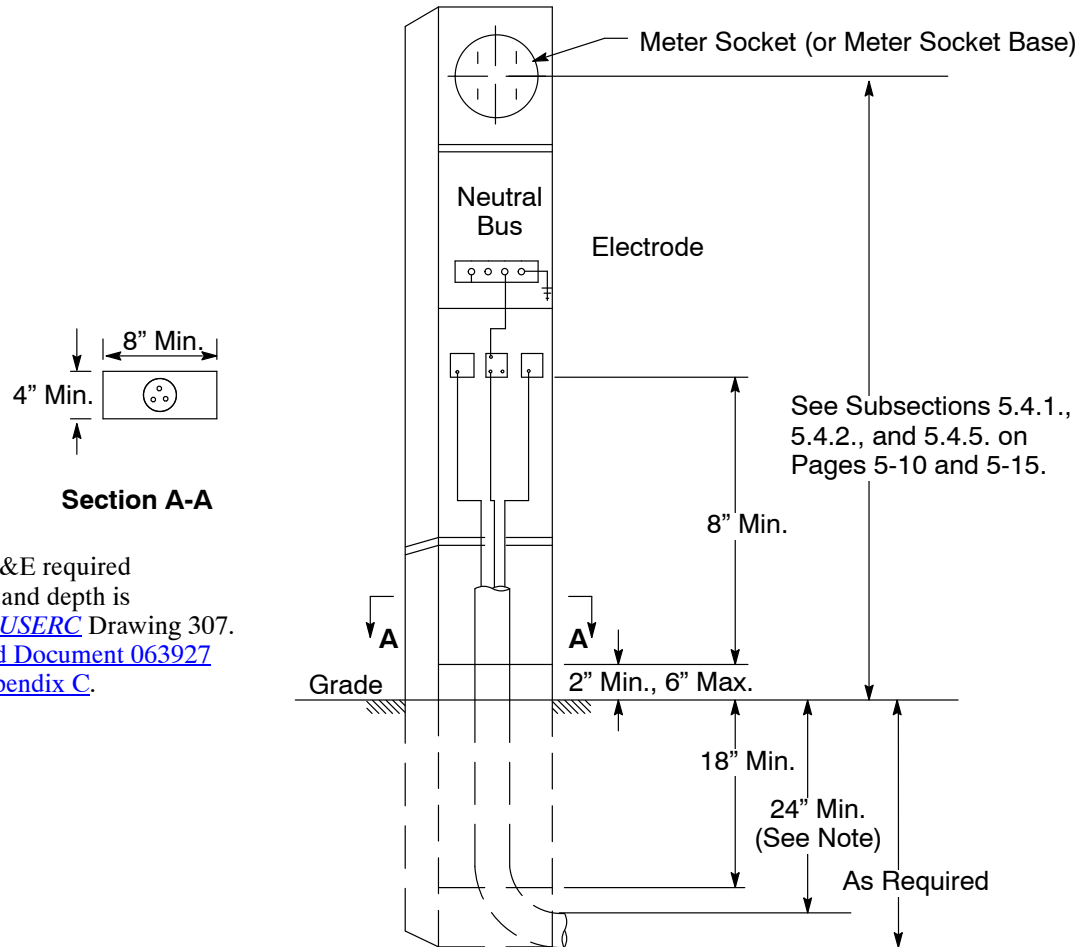

Note: The PG&E required conduit cover and depth is greater than [EUSERC](#) Drawing 307. See [Numbered Document 063927](#) located in [Appendix C](#).

Figure 6-1
Residential Electric Metering Pedestal

6.4. Meter Locations

An applicant must consult a PG&E project coordinator during the initial construction phase of his or her project to determine the appropriate meter panel and current-transformer cabinet (if installed) location and to ensure that adequate space is provided for the metering equipment. PG&E must review and approve all meter installations **before** the meters are installed.

When meters are installed in a confined or enclosed area, applicants must ensure that they design a way for PG&E personnel to read the meters from the **outside** of the enclosures (e.g., window, opening).

The following four, lettered paragraphs provide location requirements that are applicable to residential metering.

- A. Locate the meters and metering equipment either in outdoor, unfenced areas **or** mount them on, or recess them in, an exterior building wall. Do **not** mount metering equipment on, or recess metering equipment in, single family residences or inside garages.
- B. Locate the meters and metering equipment in a meter room that is accessible through an outside doorway.
- C. For a multifamily or residential building, locate the meters and metering equipment in a meter room or other acceptable location. Typically, an acceptable location will be on the ground floor or basement level of the building. The installation must be accessible directly from a public area.

An applicant who is planning to install metering equipment on any floor above the ground floor in a multistory building must contact a PG&E project coordinator as early as possible during the initial stages of the project. PG&E must approve of any equipment location that is above the building's ground level.

NOTE: In large, multifamily, multistory residential buildings (typically if the highest occupied floor is over 75 feet high), PG&E may, at its option, approve grouped meter locations on one or more upper floors.

- D. When meters will be installed indoors see the [PG&E Bulletin TD-7001B-005](#), "SmartMeter Electric Network Requirements for Indoor Meter Rooms and High-Rise Building Construction," located in [Appendix B](#).
- E. Locate electric meters in the same general area as gas meters when designing single-family residences. For clearance specifications refer to Subsection 5.4.3., "Meter Set Clearance Requirements," on Page 5-11, and [Section 2](#), "Gas Service."

6.4.1. Installing Utility Services to Mobile Homes

- A. Typically, PG&E will **not** supply utility services and/or metering facilities to mobile homes that are located or set up in any area, including a mobile home park, where utility service facilities are attached directly to the mobile home **except** under the following circumstances.
 1. The mobile home is fixed in place (i.e., no running gear or wheels). The mobile home must **not** be capable of movement.
 2. The mobile home is installed on a foundation system as described in [State of California, Title 25, Division 1, Chapter 2, Article 7, Section 1333](#), "Foundation Systems."

- B. PG&E will make an **exception** and install utility services to a location where mobile homes may be moved, including mobile home parks, under certain, specific conditions.
1. The mobile homes must be served by meter pedestals or other PG&E-approved services **and** the meter facilities must be installed at a fixed location.
 2. Applicants are responsible for connecting their mobile homes to those fixed locations and to the meter pedestals or other utility facilities.

See [Numbered Document 052521](#), “Electrical Service Requirements for Mobile Home Developments,” for more information and for specifications. This PG&E document is included in [Appendix C](#), “Electric and Gas Engineering Documents,” and also in PG&E’s [Electric Underground Construction Manual](#), Volume 1.

6.5. Services

6.5.1. Single Meter: Underground Service

A. Services, 0 Amps Through 225 Amps, Single Phase

Figure 6-2, “Typical Underground Service-Termination Enclosure, Combination Meter-Socket Panel (Residential, 0 Amps–225 Amps),” on Page 6-5, illustrates a single, underground, residential, single-phase meter panel (i.e., 4 terminal for a 120/240-volt service and 5 terminal for a 120/208-volt service).

The numbered items below describe the applicant’s requirements when designing these types of underground services.

1. Design the socket and enclosure for underground service conductors.
2. Ensure that enclosures designed for either overhead or underground service entry meet all of the requirements for **both** types of service.
3. Ensure that all cable-termination lugs are suitable to use with both aluminum and copper conductors. The lugs must be compatible with a range of conductor sizes.

The **minimum** conductor size for services up to 125 amps is #6 American wire gauge (AWG) to 1/0 AWG. The **minimum** conductor size for services rated from 126 amps to 225 amps is #2 AWG to 250 thousand circular mils (kcmil).

4. Use separate, independently supported, service-termination lugs that extend from the socket, and connect to it, using a bus bar. Provide a minimum radial clearance of 1-1/2 inches between the hot bus terminals and the ground or neutral surfaces. The termination facilities cannot be side- or angle-mounted in relation to the front of the panel.

5. Ensure that the socket enclosure has a separate lug in the sealable section. Use this lug exclusively for terminating PG&E's neutral conductor. If the neutral terminal is insulated from the enclosure, PG&E will provide the applicant with a bonding screw or jumper.
6. Ensure that the applicant-owned wiring that extends from the distribution section (i.e., branch circuits) does **not** pass through the sealable section(s).
7. Locate the applicant's service-grounding electrode conductor outside of the sealable section and design it to permit the applicant's grounding system to be isolated easily from PG&E's neutral, when necessary.

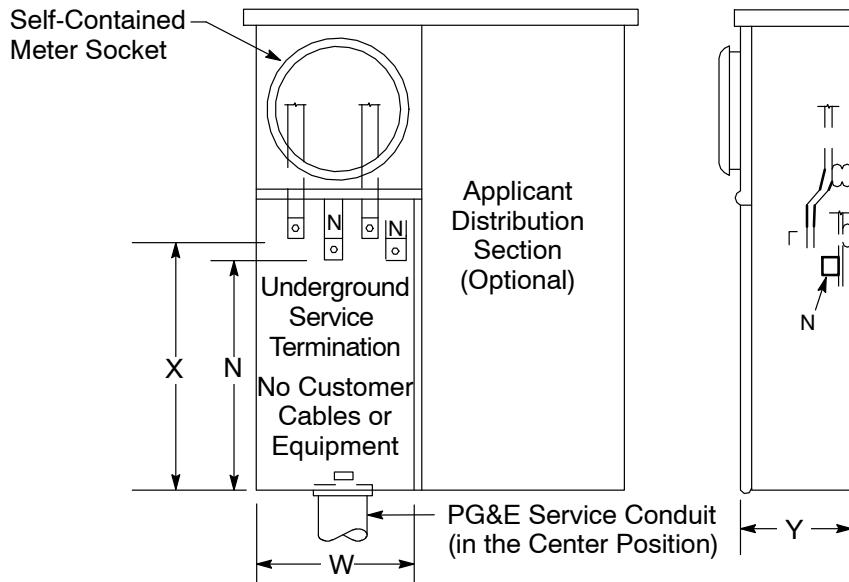

Figure 6-2
Typical Underground Service-Termination Enclosure, Combination Meter-Socket Panel
(Residential, 0 Amps-225 Amps)

Table 6-1 Residential (0 Amps-225 Amps) Enclosure

Rating in Amps	X	Y	N	W	Conduit
	Minimum Dimensions (In Inches)				
Up to 125	8	4	6	7	2
126 to 225	11	5-1/2	8-1/2	7	3

B. Services, 226 Amps Through 320 Amps, 120/240 Volts, Single Phase, Residential

Figure 6-3, “Typical Service-Termination Enclosure, Combination Meter-Socket Panel for a Class 320 Meter (Residential, 120/240-Volt, 226-Amp Through 320-Amp Service),” on Page 6-6, illustrates a single, underground, residential, single-phase, 120/240-volt, Class 320-amp meter panel. Applicants must ensure that this panel:

1. Conforms to the requirements for underground-fed, 320-amp metering equipment.
2. Is designed with test-bypass facilities and has provisions for using manual bypass links.
3. Is marked with either a rating of “320 Amperes Continuous” or “400 Amperes Maximum (320 Amperes Continuous).”
4. Is only used with residential services.

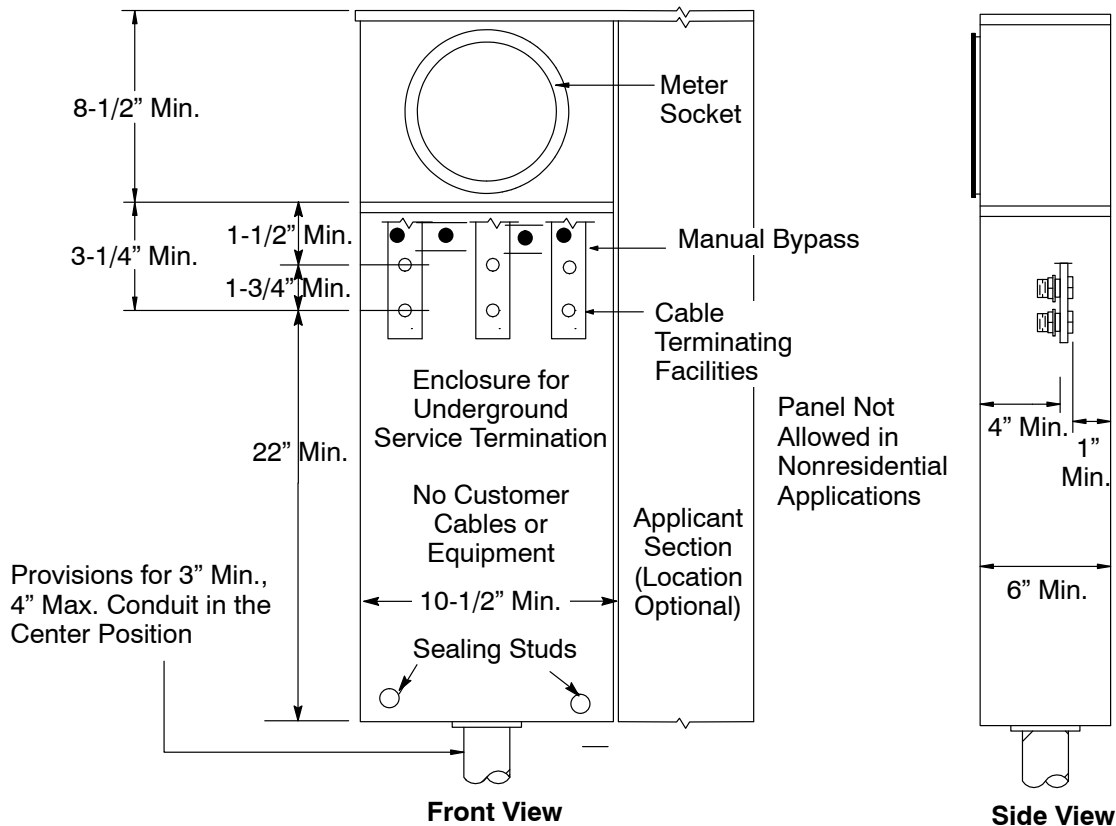

Figure 6-3
Typical Service-Termination Enclosure, Combination Meter-Socket Panel for a Class 320 Meter (Residential, 120/240-Volt, 226-Amp Through 320-Amp Service)

C. Services, 201 Amps Through 800 Amps, Single Phase or 400 Amps Three Phase with Current Transformers

Applicants **must** consult their local PG&E project coordinators when single-phase services exceed 400 amps. Applicants may need to install three-phase service to conform to PG&E's [Electric Rule 2](#), "Description of Service," requirements.

Figure 6-4, "Underground Combination Meter and Current-Transformer Cabinet (201 Amps–400 Amps; 1Ø or 3Ø)," on Page 6-8, illustrates a single-metered, underground, residential meter panel.

Figure 6-5, "Typical Underground, Separate-Bused, Current-Transformer Cabinet and Safety-Socket Meter Box Assembly, 201 Amps–400 Amps, 3Ø and 201 Amps–800 Amps, 1Ø," on Page 6-8, illustrates how service and metering components can be separated into individual enclosures.

NOTE: See [Section 9](#), "Electric Metering: Components," for details about the components in Figure 6-4 and Figure 6-5.

Applicants must ensure their conductors are installed before PG&E installs the current transformers. Also, applicants must ensure that their service-entrance conductors and equipment meet the following requirements.

1. The current transformer mounting base must include termination bolts, Belleville washers, and nuts on the line and load sides necessary to connect the PG&E current transformers and service conductors to the line side.
2. The conductor must enter the current-transformer cabinet at or within 2 inches of the top or bottom and leave the cabinet **either** at or within 2 inches of the top or bottom of the opposite end of the cabinet **or** enter and exit at or within 2 inches of the same end of the current-transformer cabinet. Route the conductor carefully when using this option.

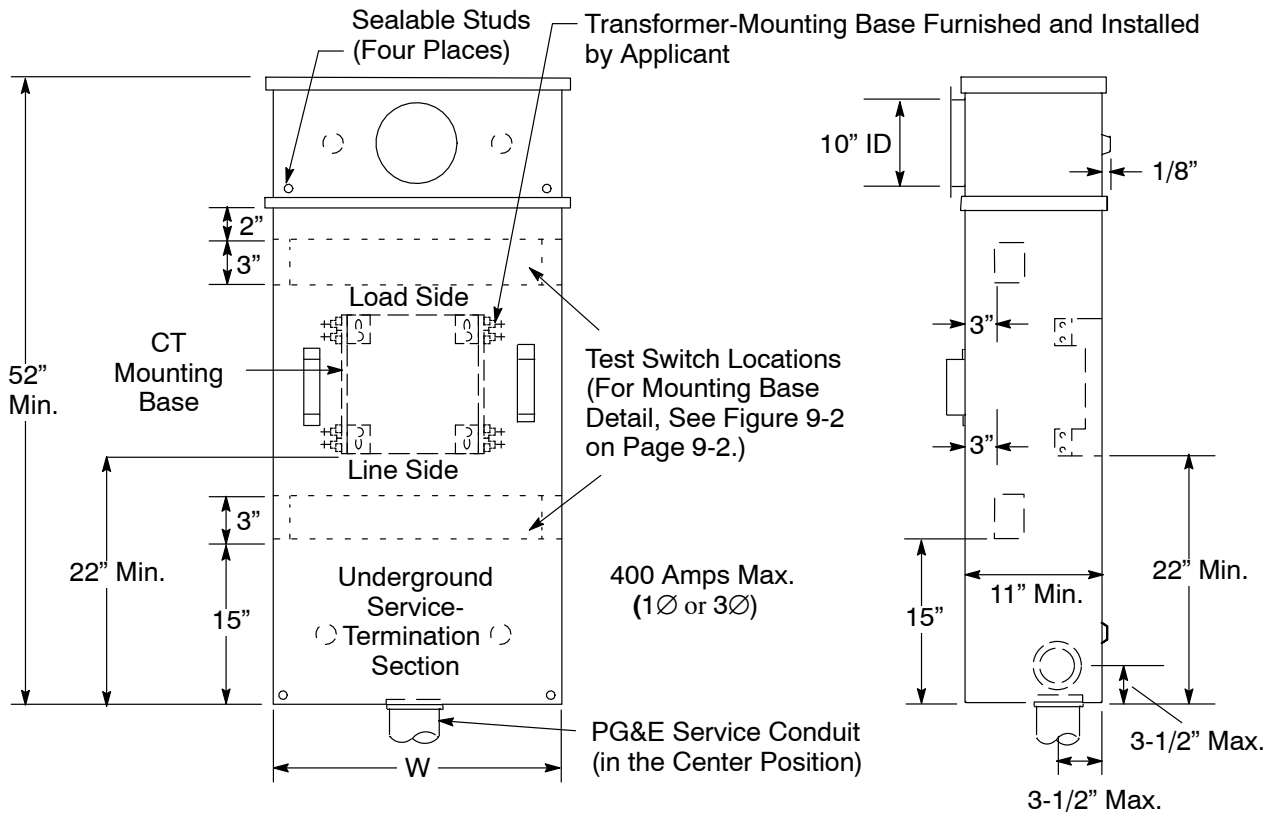

W Dimensions:
 3-Wire 1Ø = 24" Min.
 4-Wire 3Ø = 36" Min.

Figure 6-4
Underground Combination Meter and
Current-Transformer Cabinet
(201 Amps–400 Amps, 1Ø or 3Ø)

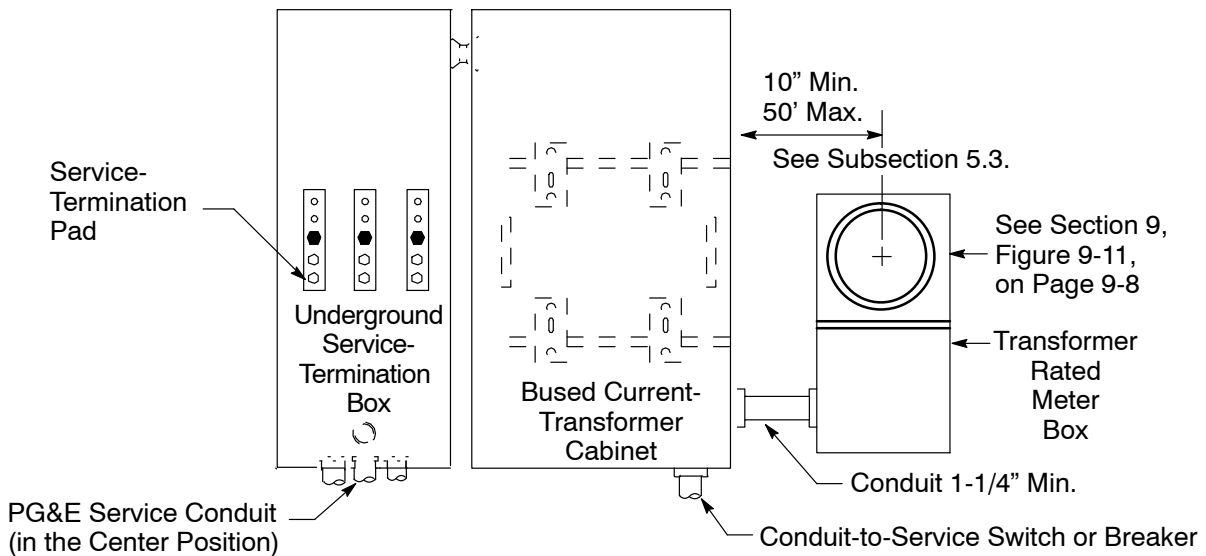

Figure 6-5
Typical Underground, Separate-Based, Current-Transformer Cabinet and Safety-Socket
Meter Box Assembly, (201 Amps–400 Amps, 3Ø and 201 Amps–800 Amps, 1Ø)

6.5.2. Single Meter: Overhead Service

A. Services, 0 Amps Through 225 Amps, Single Phase

Figure 6-6, “Individual Meter Socket,” and Figure 6-7, “Combination Meter Socket Load Center,” both on Page 6-9, illustrate the 4-terminal, 120/240-volt and 5-terminal, 120/208-volt overhead service and meter panel.

Enclosures designed for a combination of overhead and underground conductors must meet **all** of the requirements for both types of conductor entry.

B. Services, 226 Amps Through 320 Amps, 120/240 Volts, Single Phase

Applicants must ensure that this panel:

1. Conforms to the requirements for overhead-fed, 320-amp metering equipment.
2. Is designed with test-bypass facilities and has provisions for using manual bypass links.
3. Is marked with either a rating of “320 Amperes Continuous” or “400 Amperes Maximum (320 Amperes Continuous).”
4. Is only used with residential services.

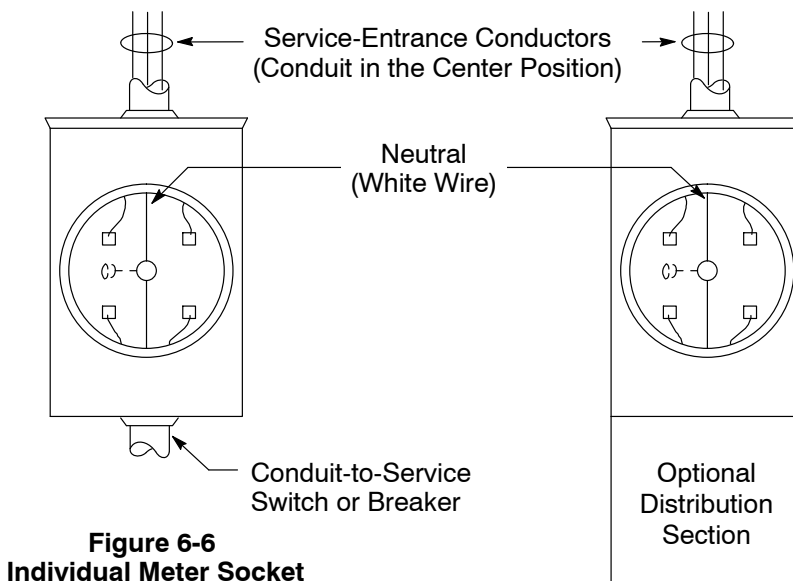

Figure 6-6
Individual Meter Socket

Figure 6-7
Combination Meter Socket Load Center

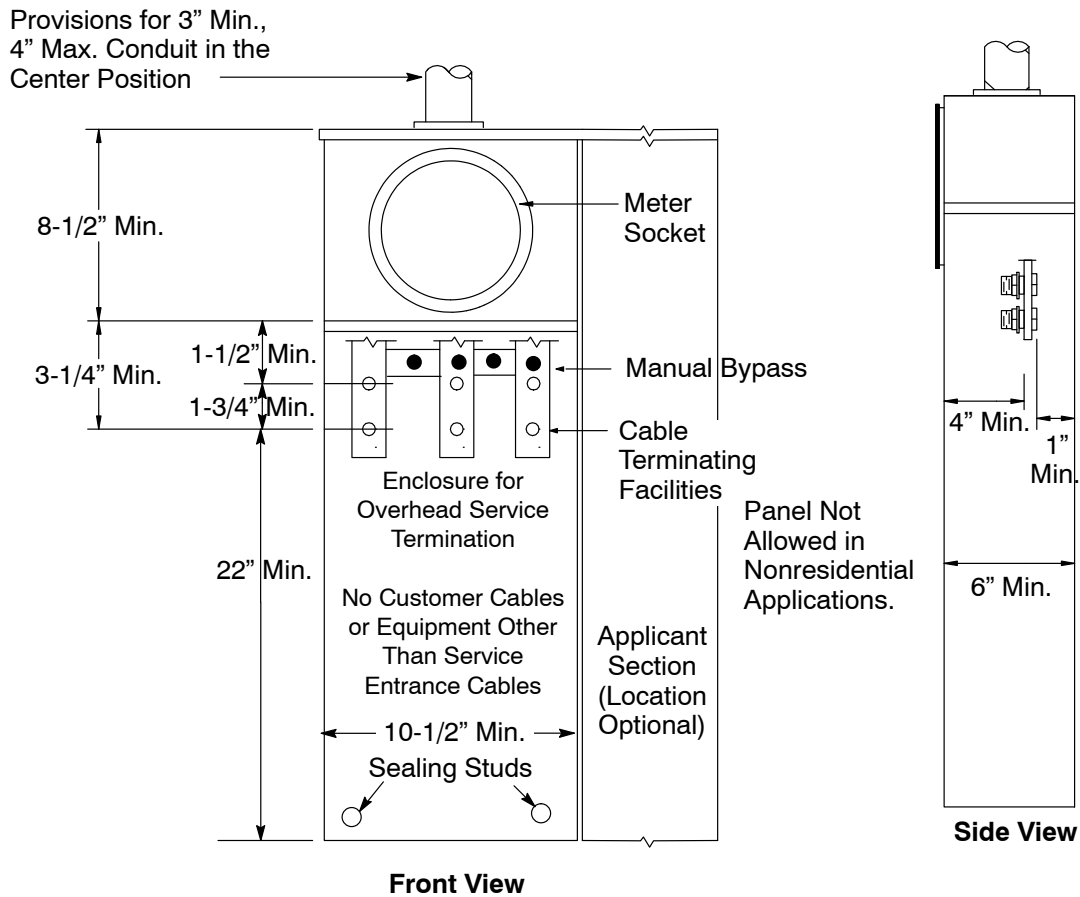

Figure 6-8
Typical Service-Termination Enclosure, Combination Meter Socket Panel for a Class 320 Meter
(Residential, 120/240-Volt, 226-Amp Through 320-Amp Service)

C. Services, 201 Amps Through 600 Amps, Single Phase, or 400 Amps, Three Phase, with Current Transformer

Applicants **should** consult with a PG&E project coordinator before installing single-phase services that exceed 400 amps. Applicants may need to install three-phase service to conform to PG&E’s [Electric Rule 2](#) requirements.

Figure 6-9, “Overhead-Fed Combination Meter and Current-Transformer Cabinet, (201 Amps–400 Amps, 3Ø and 201 Amps–600 Amps, 1Ø),” on Page 6-11, illustrates a single-metered, overhead, residential meter panel.

Figure 6-10, “Overhead-Fed, Separate-Bused, Current-Transformer Cabinet and Meter Box (201 Amps–400 Amps, 3Ø and 201 Amps–600 Amps, 1Ø),” also on Page 6-12, illustrates a single, overhead, residential, single-phase or three-phase service and meter panel with current transformers.

NOTE: See [Section 9](#), for details about the components in Figure 6-9 and Figure 6-10.

Applicants must ensure their conductors are installed before PG&E installs the current-transformers. Also applicants must connect the service entrance conductors to the line and load sides of the current-transformer mounting base.

1. The current transformer mounting base must include termination bolts, Belleville washers, and nuts on the line and load sides necessary to connect the PG&E current transformers. See [Section 9](#), for details about these internal components.
2. The conductor must enter the current-transformer cabinet at or within 2 inches of the top or bottom and leave the cabinet **either** at or within 2 inches of the top or bottom of the opposite end of the cabinet **or** enter and exit at or within 2 inches of the same end of the cabinet. **Applicants must ensure that the conductor is routed carefully when using this option.**

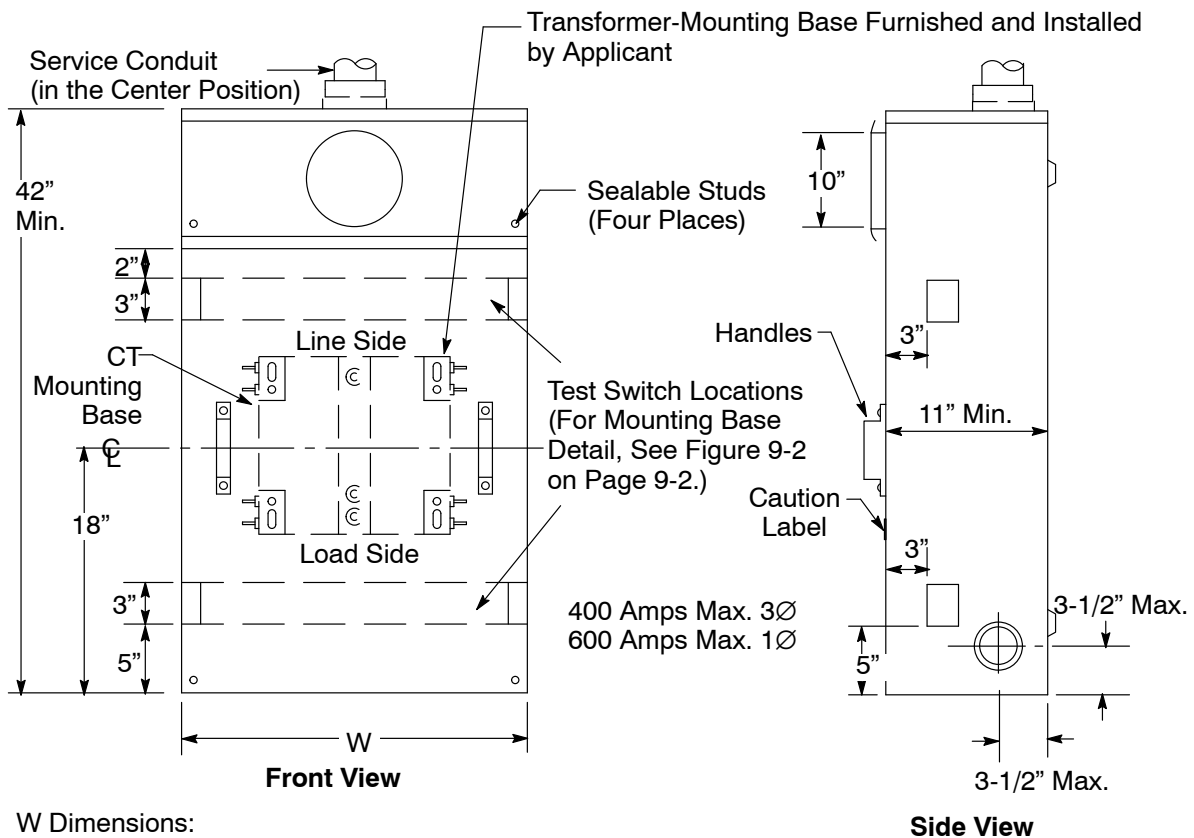

W Dimensions:
 3-Wire 1Ø = 24" Min.
 4-Wire 3Ø = 36" Min.

Figure 6-9
Overhead-Fed Combination Meter and Current-Transformer Cabinet,
(201 Amps–400 Amps, 3Ø and 201 Amps–600 Amps, 1Ø)

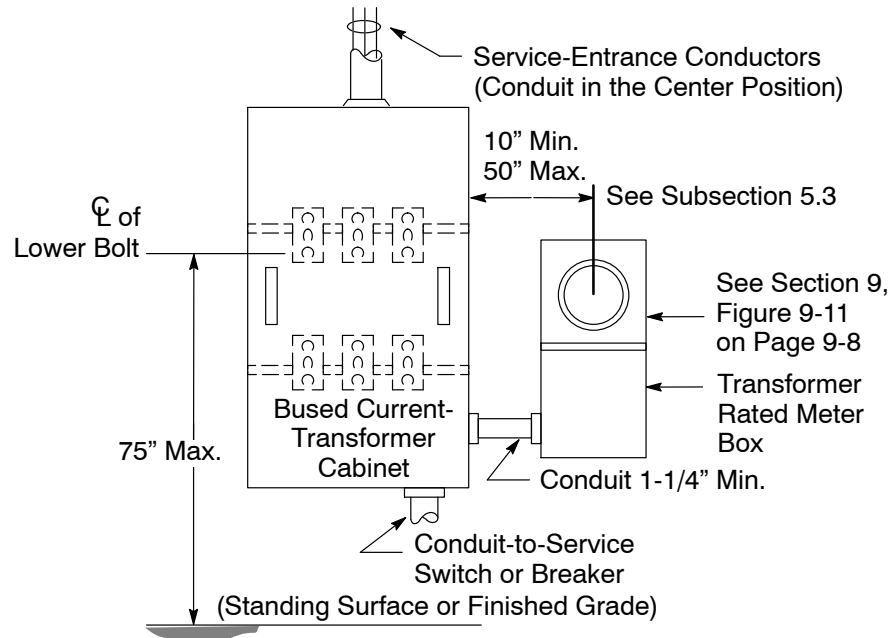

Figure 6-10
Overhead-Fed, Separate-Based, Current-Transformer Cabinet and Meter Box
 (201 Amps–400 Amps, 3Ø and 201 Amps–600 Amps, 1Ø)

6.5.3. Multiple Meters

PG&E requires grouped, single-meter installations for multifamily residential buildings.

This requirement excludes row-type condominiums where each unit is considered a single-family residence and is metered individually. Row-type condominiums must meet the applicable metering requirements described in the following subsections.

A. Grouped-Meter Installation Ampacity Ratings

The ampacity rating of a grouped-meter installation must be as described below.

1. For installations **without** a main switch or breaker, the service rating will be the rating of the electrical enclosure or service termination section, pull can, or other service-termination enclosure where PG&E terminates and connects its supply facilities and conductors. Also, see Subsection 1.14.B. on Page 1-12.
2. For installations **with** a main switch or breaker, the rating of the service to be supplied is the rating of the termination section, pull can, service section, or main service switch continuous current rating, typically whichever is greater. Also, see Subsection 1.14.A. on Page 1-12.

B. Grouped Meter-Socket Spacing and Socket Blank-Off Covers

PG&E requires a 7-1/2-inch horizontal and 8-1/2-inch **minimum** vertical center spacing between meter sockets. The Company will provide and install nonconductive, meter-socket, blank-off covers **before** energizing the meter panels with vacant meter sockets. PG&E will **not** energize meter panels and sockets unless blank-off meter covers are installed.

C. Individual Meter Sockets With Wiring Gutters

PG&E will accept meter sockets with wiring gutters, as shown in Figure 6-11, “Meter Sockets With Wiring Gutters,” on Page 6-13, only when applicants either are updating and/or adding on to existing installations.

PG&E will accept individual meter sockets in combination with a wiring gutter **only** for an applicant’s service-entrance conductors and **only** when unmetered service-entrance conductors and metered-load conductors are **not** installed in the same conduit, raceway, or wiring gutter.

To conserve space and lower equipment costs, applicants should consider installing a combination multimeter, as described in Subsection 6.5.3.D., “Combination Multimeter Installation,” on Page 6-14. Only if applicants are reconstructing or adding to an existing installation can they install a meter trough, as described in Subsection 6.5.3.E., “Meter Trough Installations,” on Page 6-17.

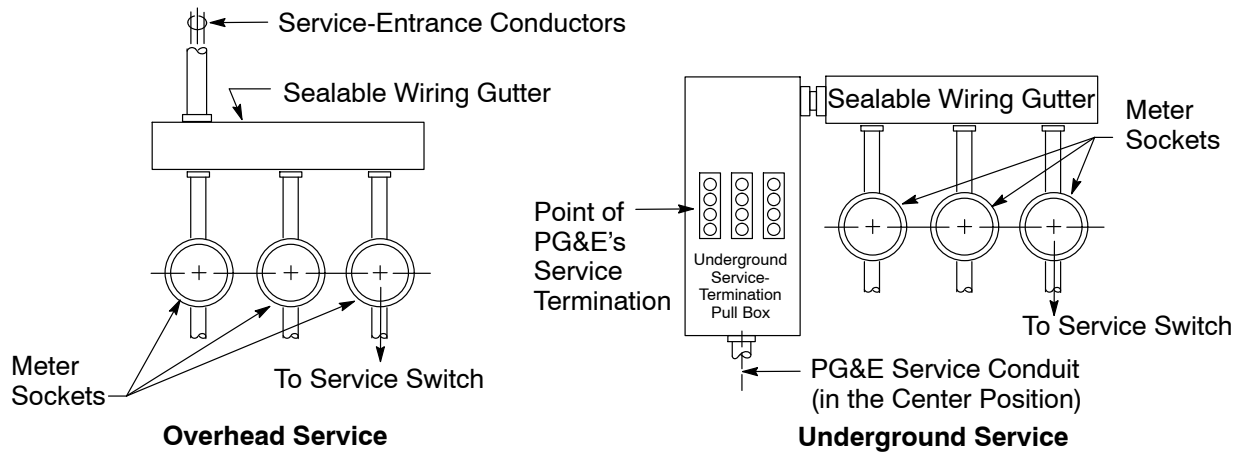

Figure 6-11
Meter Sockets With Wiring Gutters

D. Combination Multimeter Installation

A combination multimeter installation consists of the following equipment.

- A main switch (if one is installed or required by local jurisdiction)
- Unmetered wiring gutter
- Multiple meter sockets
- An appropriate number of circuit breakers

See [Section 5](#), Subsection 5.7., “Main Service Disconnects and Switching Sequences,” on Page 5-22, for more information on disconnects and switches.

Examples of PG&E-approved, combination, multimeter installations are illustrated in Figure 6-12, “Typical, Manufactured, Combination, Multimeter Installation: Seven Meters or More,” on Page 6-15, and Figure 6-13, “Clearances for a Typical, Manufactured, Combination, Multimeter Installation,” on Page 6-16.

Applicants must ensure that all multimeter installations meet the following requirements.

1. Individually meter multiple apartments in one building. Separate metered and unmetered conductors.
2. Use factory (or factory-equivalent), harness-style wiring **or** bus between the unmetered wiring gutter and the line terminals of each meter socket. Harness-style wiring or bus also must be used between the load terminals of each meter socket and the line side of the corresponding circuit breaker.
3. Ensure that the panels are designed to permit any individual meter socket block or jaw assembly to be replaced. Applicants must **not** mount more than two meters on a single, removable panel. Removable meter-panel covers must **not** exceed 6 square feet in area.
4. Ensure that the panel’s design and construction meets the clearance requirements provided in Figure 6-13 and in Table 6-2, “Dimension Specifications for Multimeter Installations,” on Page 6-16.
5. Increase Dimension B, shown in Figure 6-13 on Page 6-16, by the amount that the main switch door, including the operating handle, reduces the clearance when opened 90°.
6. Ensure that panels are removable so that PG&E personnel can perform wiring inspections.

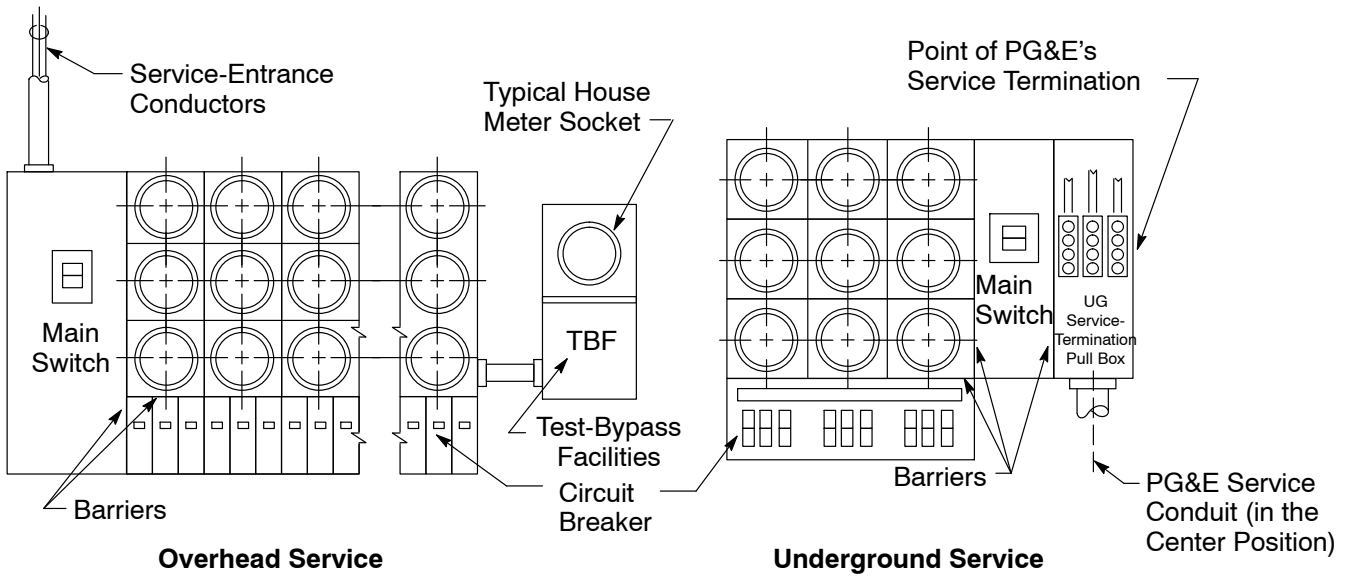

Figure 6-12
Typical, Manufactured, Combination, Multimeter Installation: Seven Meters or More

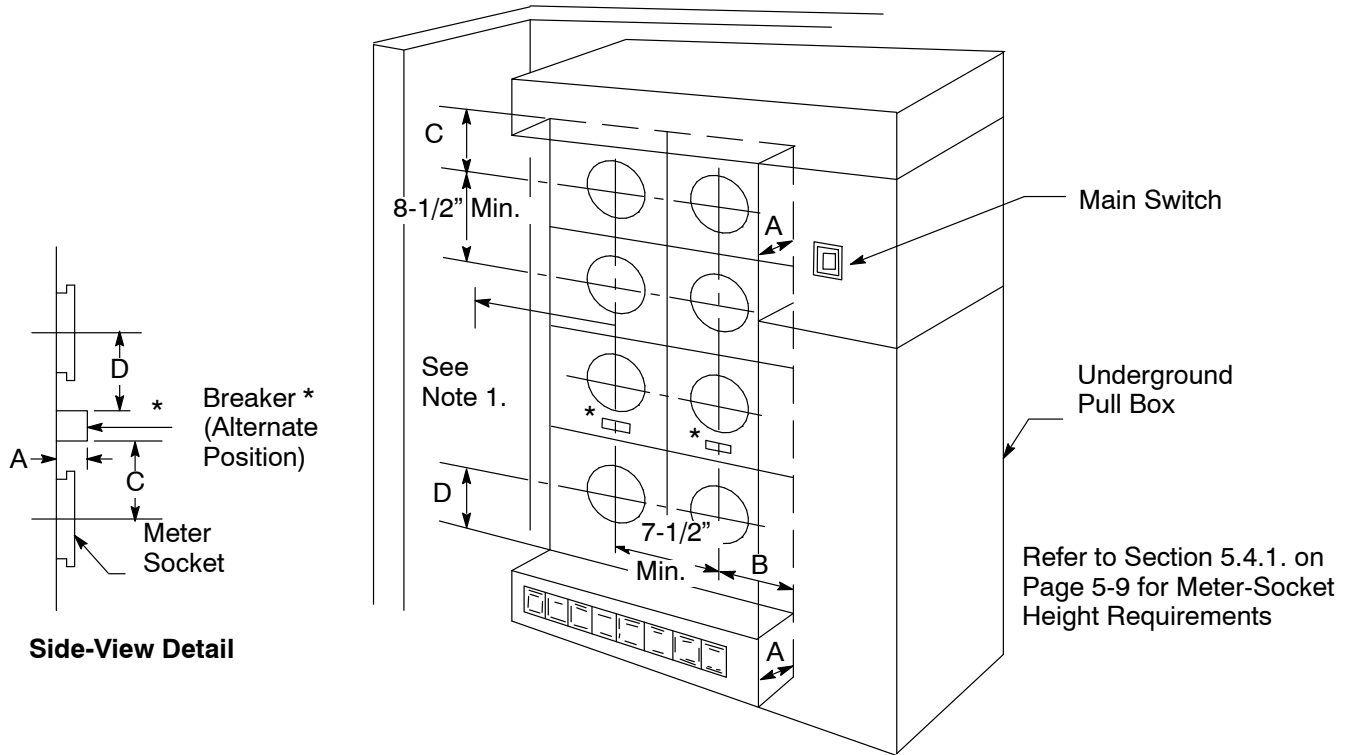

Figure 6-13
Clearances for a Typical, Manufactured, Combination, Multimeter Installation

Notes in reference to Figure 6-13.

1. Where an adjacent wall or other obstruction extends more than 11-inches perpendicular from the face of the meter panel, a 10-inch minimum dimension to the meter socket axis is required. For obstructions extending 11 inches or less from the meter panel, the side clearance must conform to that of Dimension B.

Table 6-2 Dimension Specifications for Multimeter Installations

A—Protrusions (in Inches)	B	C	D
	All Measurements Are Minimum Dimension in Inches		
0 (No Protrusion)	3-3/4	4	4-3/4
Greater Than 0 to 1-1/8	4-1/4	4	4-3/4
Greater Than 1-1/8 to 2	4-1/4	4-1/4	6-1/4
Greater Than 2 to 4	6-1/4	4-1/4	8
Greater Than 4 to 11 (Maximum)	6-1/4	10	8

E. Meter Trough Installations

PG&E accepts meter trough installations using ring-type sockets only for reconstructing and adding to existing installations. In addition to meeting the general requirements for meter sockets, applicants must ensure that meter troughs meet the following general requirements.

1. Where there are four, five, or six sockets in one trough, the incoming service conductors must terminate on a main bus that is supported independently of the socket jaw assembly.
2. The panel design must permit individual, meter-socket blocks or jaw assemblies to be replaced individually. Applicants must **not** mount more than two meters on a single, removable front panel.
3. Metered and unmetered conductors must be separated, clearly showing that the entire load is being metered.
4. The panels must be removable so that wiring inspections can be performed.

Figure 6-14 and Figure 6-15, both located below, illustrate meter trough installations served by underground or overhead service.

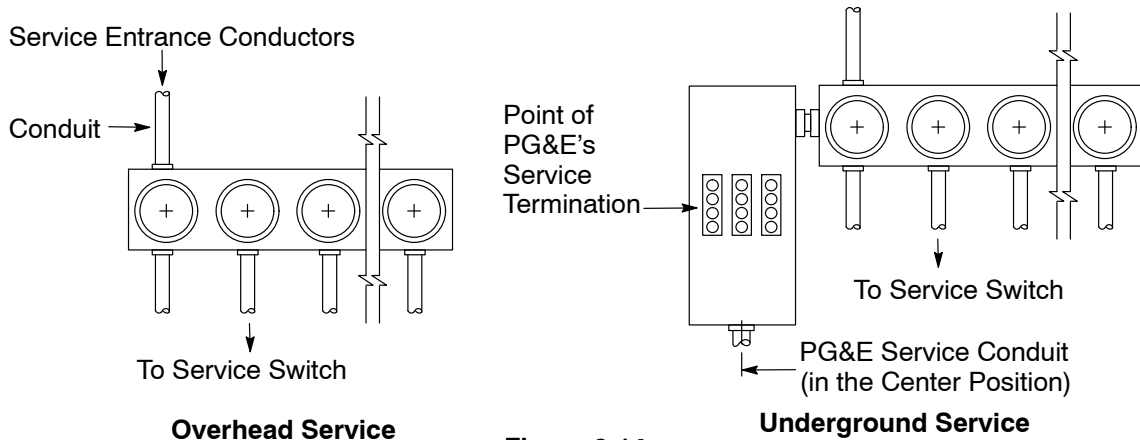

Figure 6-14
Horizontal Meter Trough Installation: Six Meters or Less

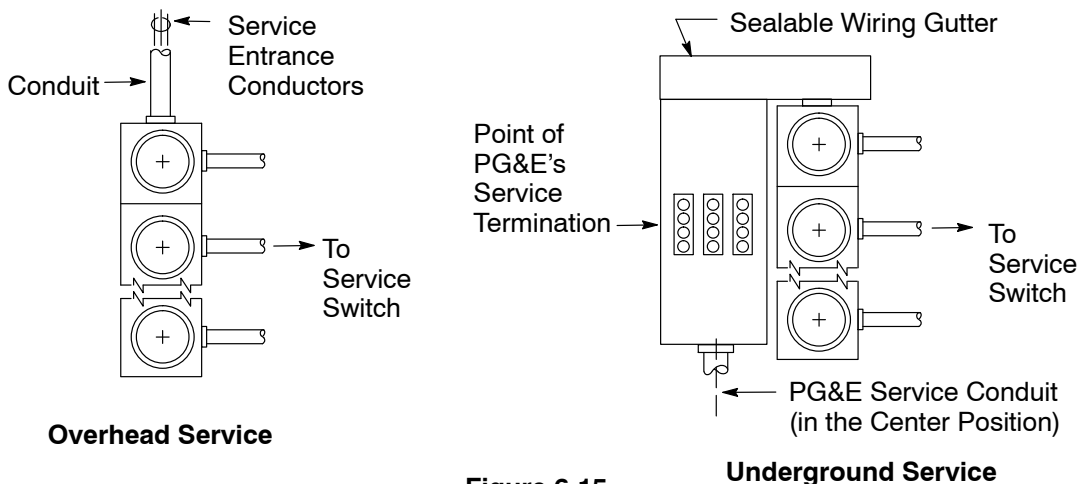

Figure 6-15
Vertical Meter Trough Installation: Five Meters or Less

This Page Intentionally Left Blank

SECTION 7
ELECTRIC METERING:
COMMERCIAL, INDUSTRIAL,
AND AGRICULTURAL

**SECTION 7 ELECTRIC METERING: COMMERCIAL, INDUSTRIAL AND
AGRICULTURAL**

**SECTION 7 ELECTRIC METERING: COMMERCIAL, INDUSTRIAL AND
AGRICULTURAL**

Section 7

Electric Metering: Commercial, Industrial, and Agricultural

7.1. Scope

This section of the manual provides the Pacific Gas and Electric Company (PG&E/the Company) service specifications and requirements for commercial, industrial, and agricultural electric metering. Also, it describes the required locations for these nonresidential meters. This section includes specific information that is **not** covered by the basic requirements in [Section 5](#), “Electric Metering: General.”

NOTE: Residential meter panels rated for 320 amperes (amps) shown in [Section 6](#), “Electric Metering: Residential,” are not allowed to be used for nonresidential (e.g., commercial, industrial, and agricultural) applications.

7.2. Service Specifications and Requirements

The following three subsections describe service specifications and requirements for commercial, industrial, and agricultural electric meters.

7.2.1. Permitted Types of Electric Service

PG&E does **not** permit overhead service connections in areas zoned for underground service by local ordinance, or where underground service is required by [California Public Utility Commission](#)- (CPUC-) approved tariffs.

7.2.2. Required Test-Bypass Facilities

Test-bypass facilities are required, regardless of the panel ampacity, for both single-phase and three-phase, nonresidential installations. Applicants must furnish, install, and maintain a meter socket with PG&E-approved, manual, test-bypass facilities. This equipment also is used for the following types of services.

- All three-phase, nonresidential services **without exception**.
- All single-phase, nonresidential services. See the exceptions in Subsection 7.2.3., “Required Approvals for Meter Equipment Without Test-Bypass Facilities,” on Page 7-2.

Refer to Figure 7-1, “Bused, Safety-Socket Meter Box for Self-Contained Metering (0 Amps–125 Amps),” on Page 7-4, and Figure 7-2, “Bused, Safety-Socket Meter Box for Self-Contained Metering (126 Amps–200 Amps),” on Page 7-5.

7.2.3. Required Approvals for Meter Equipment Without Test-Bypass Facilities

PG&E requires an approval **before** installing meter equipment without test-bypass facilities. If approved, the meter equipment may be exempt only when all of the conditions are met in Item 7.2.3.A. or Item 7.2.3.B., both below.

- A. Single-phase, nonresidential service when **all** of the three following conditions are met.
 - 1. The main disconnect switch's rating does **not** exceed 200 amps.
 - 2. Service to another meter or service will **not** be interrupted when de-energizing the meter socket without test-bypass facilities.
 - 3. The metered service is used **exclusively** for temporary power or nighttime lighting loads.
- B. Single-phase, 120/240-volt residential customers who establish a new agricultural service, or have an existing agricultural service, and that service is connected to a residential, main-service electric panel may be exempt from the test-bypass requirement only when **all** of the three following conditions are met.
 - 1. The residential main meter panel and main disconnect switch's rating does **not** exceed 225 amps.
 - 2. The customer agrees to short interruptions of service required when PG&E tests and maintains their meters.
 - 3. The aggregated total size of pump motors attached to the agricultural service do **not** exceed 7-1/2 horsepower (hp).

7.2.4. Meter Locations

Applicants must consult their local PG&E project coordinators during the initial construction phase of their projects to determine the appropriate meter and current-transformer cabinet locations and to ensure that adequate space is provided for the metering equipment. PG&E must review and approve all metering equipment installations **before** they are installed.

Additionally, the following **specific** location requirements apply to nonresidential metering.

- A. Applicants must locate meters on exterior, ground-floor walls or other permanent structures nearest PG&E's distribution facilities. When outdoor meter locations are **not** practical, PG&E will approve interior locations if they are accessible during PG&E's typical working hours **and** if the interior location meets PG&E's access requirements, as described in Subsection 5.3., "Electric Meters: General Location Requirements," on Page 5-5.

- B. Typically, applicants **must** group meters for multiple-occupancy buildings at one common location; however, PG&E allows the following **exceptions** to this requirement.
1. PG&E may permit applicants to have individual meters located on their premises if the installations comply with all applicable codes. When buildings contain unmetered wiring, applicants must place that wiring in PG&E-approved conduit and/or in sealable wireways.
 2. In high-rise buildings (e.g., typically if the highest-occupied floor is over 75 feet high), PG&E has the option to approve grouped-meter locations on one or more floors.
 3. PG&E does not permit transformer-rated metering equipment to be located at a point away from the service disconnect means, allowing the applicants to separate the meter and metering transformers. **Any exceptions to this requirement must be approved** by the local PG&E meter shop. Meter shop employees must approve remote meter locations **before** applicants locate meters away from (i.e., remote from) the PG&E service termination point. Also, applicants must provide clearances and working space, as described in Subsection 5.4., “Meter Height Clearances, Enclosures, and Protection,” on Page 5-9, for both the meter and metering transformer installations.

Applicants must supply and install rigid steel conduit for the meter wiring between the meter and the metering transformers. The conduit must be 1-1/4-inch minimum diameter and must be limited to 50 circuit feet with a maximum of three 90° bends, **unless** sealable, accessible, exposed conduits are furnished.

When meters are separated by more than 50 circuit feet, PG&E requires a special review and approval for the installation.

7.2.5. Services, 0 Amps Through 200 Amps, Single Applicant, Overhead and Underground

Applicants must meet the following requirements when installing services.

- A. PG&E’s service conductors must be pulled into the enclosure and connected to the bypass-test facility’s line-termination lugs.
- B. One set (i.e., one conductor per phase) of load conductors must be routed and formed to allow PG&E to pull their service laterals without encountering any obstructions.
- C. For overhead service, applicants must provide and install service-entrance conductors from the weatherhead to the enclosure. Applicants must connect the conductors to the bypass-test facility’s line-termination lugs.
- D. The right side, test-bypass blocks (i.e., two poles) are identified as the power leg (i.e., high leg or stinger leg) for metering three-phase, 4-wire, delta service. The power leg is identified by using the color orange. Orange tape is typically used.

- E. All section covers can be removed independently; however, after the meter is in place, the upper cover must **not** be removable. After the meter is in place, the lower cover must be sealable.
- F. For meter socket jaw requirements, see [Section 5](#), Subsection 5.6., “Meter Types and Connections,” on Page 5-17.
- G. Install range-taking lugs from #6 American wire gauge (AWG) to 1/0 AWG for services up to 125 amps, and #2 AWG to 250 thousand circular miles (kcmil) for services rated from 126 amps through 200 amps.
- H. For all agricultural overhead services, install a cable protector around one set (i.e., one conductor per phase) of service-entrance conductors entering the meter panel. Order using Material Code 382034 or 382045, found in [Numbered Document 062288](#), “Underground Conduits,” Table 14, “Codes for Cable Protectors,” on Page 8 (in [Appendix C](#)).

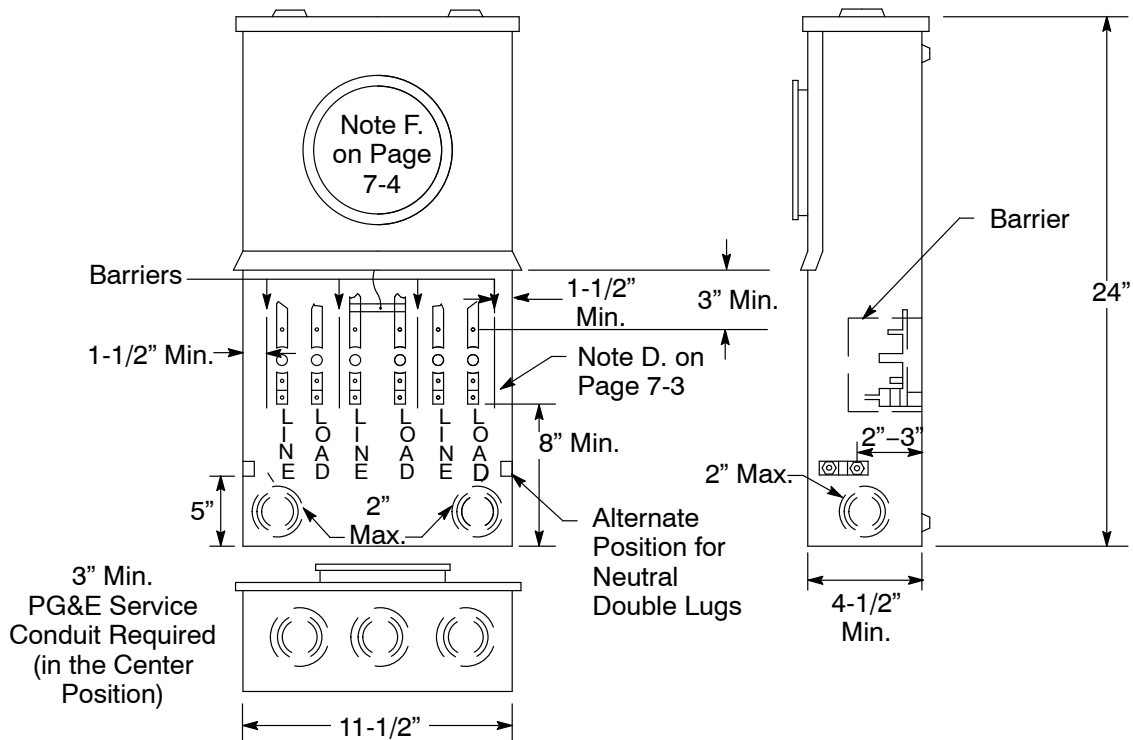

Figure 7-1
Bused, Safety-Socket Meter Box for Self-Contained Metering (0 Amps–100 Amps)

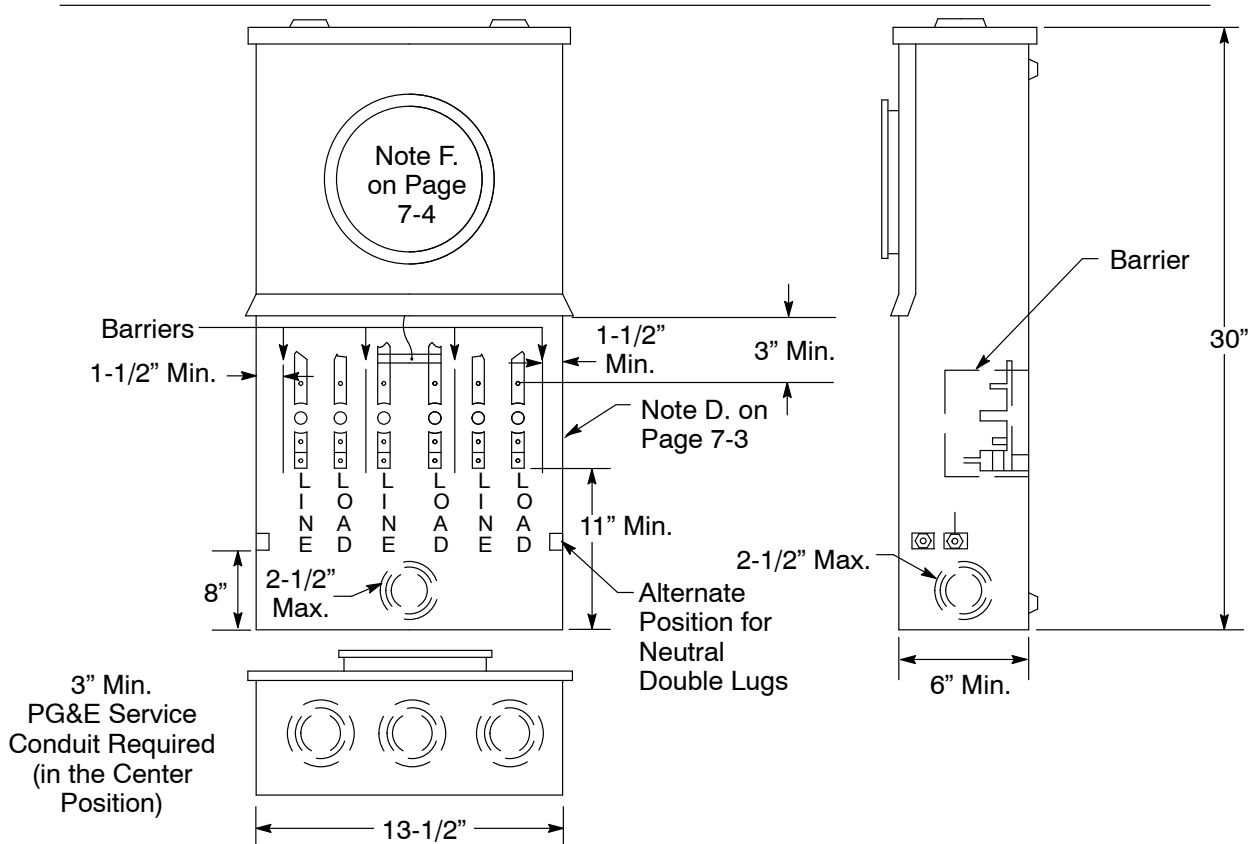

Figure 7-2
Bused, Safety-Socket Meter Box for Self-Contained Metering (101 Amps–200 Amps)

7.2.6. Services, Over 200 Amps, Single Applicant, Underground

Applicants must meet the following requirements when installing services and equipment.

A. Services, 201 Amps Through 400 Amps, Three Phase, and 201 Amps Through 600 Amps, Single Phase

1. When planning a single, underground, single-phase or three-phase service, applicants must furnish, install, own, and maintain combination meter and current-transformer cabinets, as illustrated in Figure 7-3, “Underground Combination Meter and Current-Transformer Cabinet (201 Amps–400 Amps, 1Ø or 3Ø),” on Page 7-7.

NOTE: See [Section 9](#), “Electric Metering: Components,” for details about internal components.

2. The current transformer mounting base must include termination bolts, Belleville washers, and nuts on the line and load sides necessary to connect the current transformers and the PG&E service conductors to the line side.

3. Applicants must install one set (i.e., one conductor per phase) of load conductors **before** PG&E installs the current-transformers. Also, the conductors must leave the cabinet by one of the following two methods:

- Above the current-transformer mounting base.
- At or within 2 inches of the bottom of the underground termination pull section.

One set (i.e., one conductor per phase) of load conductors must exit (i.e., leave) the current-transformer cabinet either at or within 2 inches of the top or bottom of the opposite end of the cabinet **or** exit at or within 2 inches of the same end of the cabinet.

Applicants must ensure that the conductors are routed carefully when using this option.

Applicants must ensure that one set (i.e., one conductor per phase) of load conductors are routed and formed to allow PG&E to pull their service laterals without encountering any obstructions.

4. Applicants must ensure that provisions are made for the underground service neutral when installing an insulated, bondable termination in the current-transformer cabinet.
5. Applicants must mark the power leg (i.e., high leg or stinger leg) of a 240/120-volt, three-phase, 4-wire delta service by using the color orange. This is for metering purposes. Orange tape is typically used.
6. Applicants must ensure that cabinets meet the following requirements.
 - All panels and covers must be sealable and all securing screws must be captive.
 - Outdoor current transformer (CT) cabinets are weatherproof.
 - A neutral is bonded to the enclosure.
 - CT cabinets are **not** used as splicing chambers and CTs are **not** tapped off to supply other meters or used for other purposes.

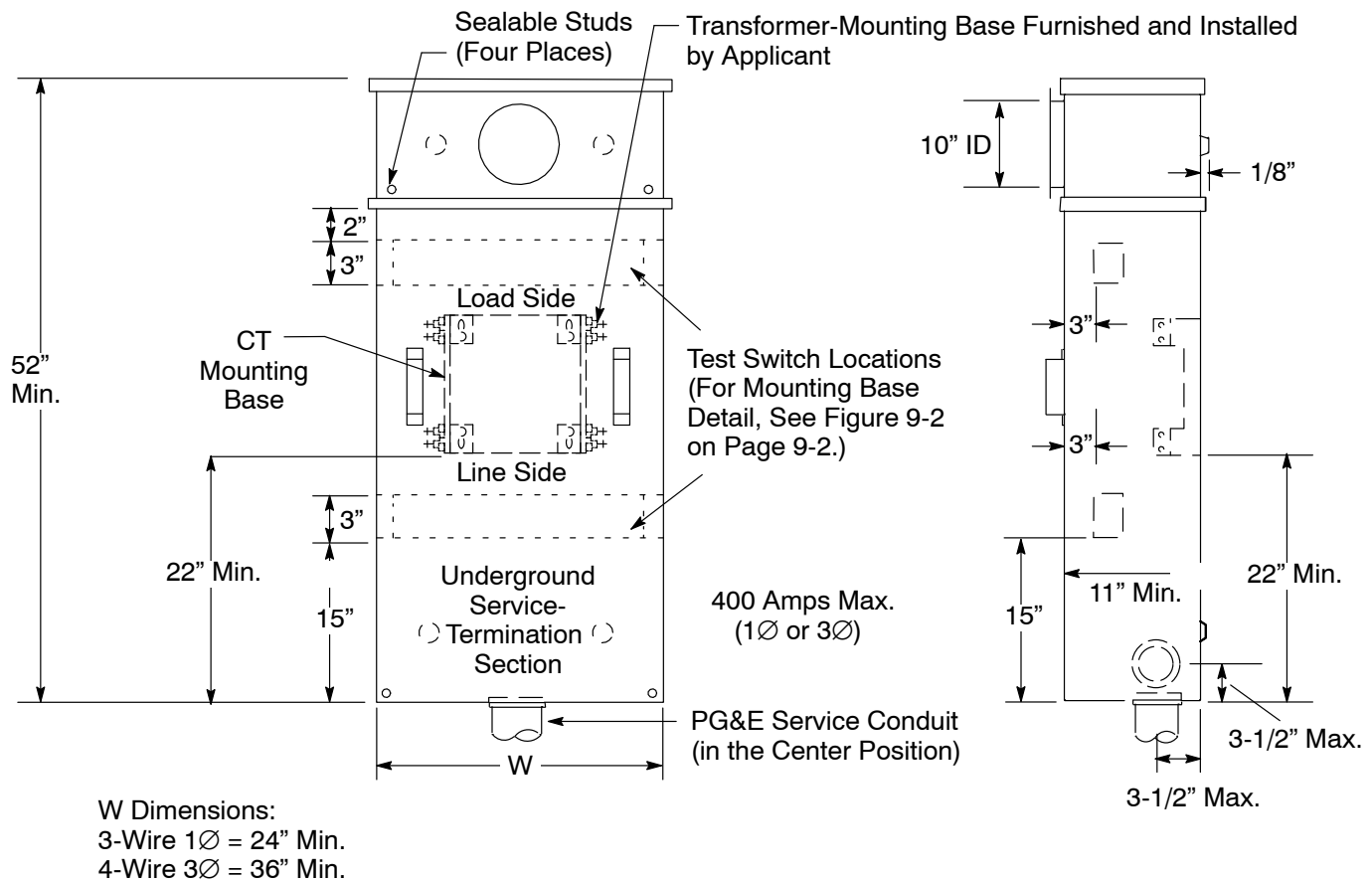

Figure 7-3
Underground Combination Meter and Current-Transformer Cabinet
 (201 Amps–400 Amps, 1Ø or 3Ø)

B. Services, 201 Amps Through 400 Amps, Three Phase, and 201 Amps Through 600 Amps, Single Phase, Current-Transformer Metering in Bused, Current-Transformer Cabinets

1. When applicants meter a single, underground service using current transformers, they must furnish, install, own, and maintain underground, service-termination pull boxes with separate, current-transformer cabinets and meter box, as illustrated in Figure 7-4, “Separate-Bused Current-Transformer Cabinet and Meter Box With Underground Service-Termination Pull Box (201 Amps–400 Amps, 3Ø, and 201 Amps–600 Amps, 1Ø),” on Page 7-8.

NOTE: See [Section 9](#), for details about internal components.

2. Applicants must furnish and connect one set (i.e., one conductor per phase) of service-entrance conductors to the line and load sides of the current-transformer mounting base and to the load side of the termination facilities in the underground, service-termination pull box. The applicants service-entrance conductors must be installed before PG&E installs the current transformers.

3. The current-transformer mounting base must include termination bolts, Belleville washers, and nuts on the line and load sides necessary to connect the PG&E current transformers.
4. PG&E pulls and terminates its service-entrance conductor directly to the applicant-furnished, service-termination facility in the underground service-termination pull box.
5. One set (i.e., one conductor per phase) of service-entrance conductors must enter current-transformer cabinets either at or within 2 inches of the top or bottom and leave the cabinet either at or within 2 inches of the top or bottom of the opposite end of the cabinet **or** enter and exit at or within 2 inches of the same end of the cabinet. **Applicants must ensure that the conductors are routed carefully when using this option.**

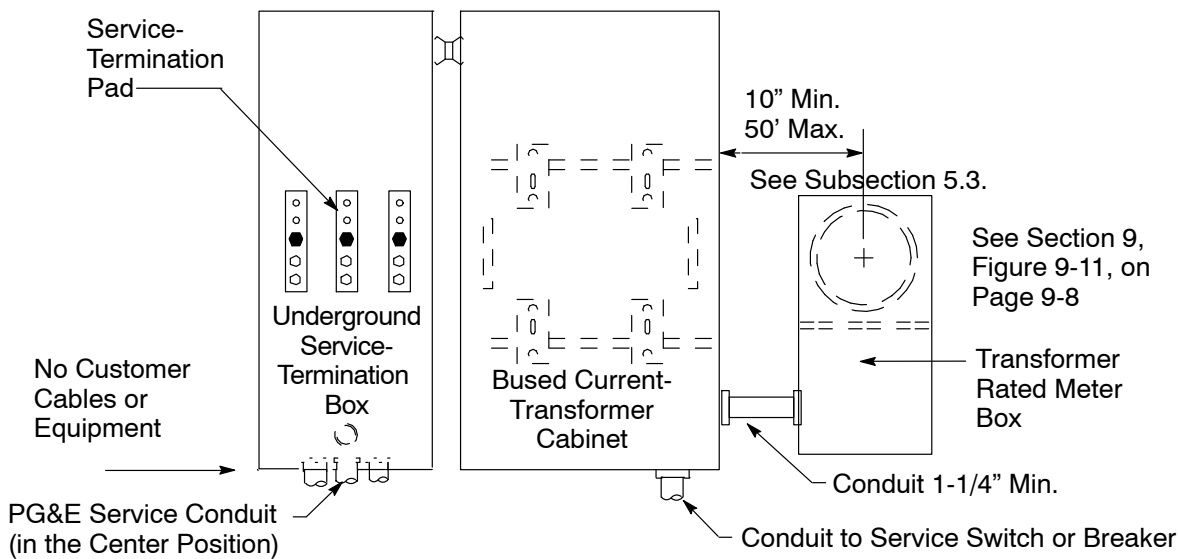

Figure 7-4
Separate-Based Current-Transformer Cabinet and Meter Box
With Underground Service-Termination Pull Box
(201 Amps–400 Amps, 3Ø and 201 Amps–600 Amps, 1Ø)

C. Services, 201 Amps and Above, Current-Transformer Metering in Switchboard Service Sections

1. When applicants meter a single underground service using current transformers, they must furnish, install, own, and maintain a switchboard service section and facilities for terminating underground service conductors.
2. Figure 7-5, “Switchboard Pull Section,” Figure 7-6, “Separate Pull Box,” and Figure 7-7, “Bottom-Fed Service Section,” all on Page 7-9, illustrate typical arrangements of the switchboard service sections that are used in conjunction with a pull section or pull box for underground service-conductor termination.

3. PG&E pulls and terminates its service conductors directly to the applicant-furnished service-termination facilities in the underground service-termination pull section, pull box, or service section.

NOTE: See [Section 10](#), “Electric Switchboards: 0 Volts Through 600 Volts,” for details.

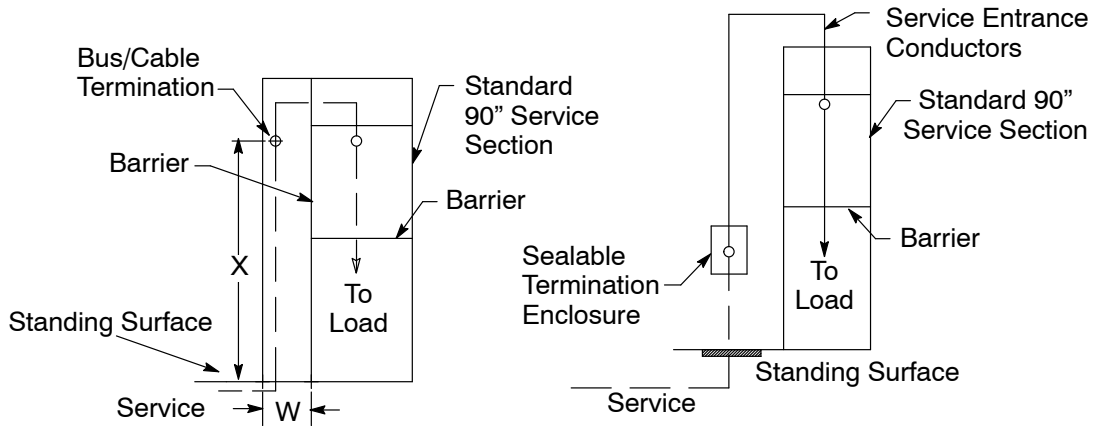

Figure 7-5
Switchboard Pull Section

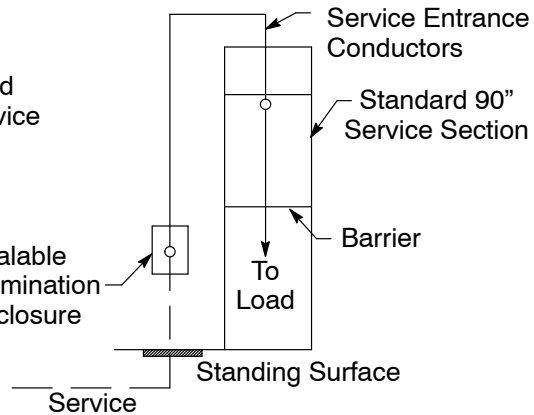

Figure 7-6
Separate Pull Box

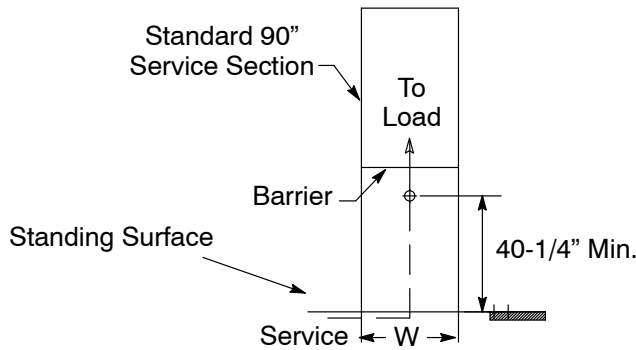

Figure 7-7
Bottom-Fed Service Section

7.2.7. Services, Over 200 Amps, Single Applicant, Overhead

Applicants must meet the following requirements when installing single-applicant, overhead services that are over 200 amps.

NOTE: For all agricultural overhead services, install a cable protector around one set (i.e., one conductor per phase) of service-entrance conductors entering the meter panel. Order using Material Code 382034 or 382045, found in [Numbered Document 062288](#), Table 14, on Page 8 (in [Appendix C](#)).

A. Services, 201 Amps Through 400 Amps, Three Phase, and 201 Amps Through 600 Amps, Single Phase

1. When installing a single, overhead, single-phase or three-phase service, applicants must furnish, install, own, and maintain combination meter and current-transformer cabinets, as illustrated in Figure 7-8, “Overhead-Fed Combination Meter and Current-Transformer Cabinet, (201 Amps–400 Amps, 3Ø and 201 Amps–600 Amps, 1Ø),” shown on Page 7-11. See [Section 9](#) for details about internal components.
2. Applicants must install one set (i.e., one conductor per phase) of service-entrance conductors before PG&E installs the current-transformers. Also applicants must connect the service entrance conductors to the line and load sides of the current-transformer mounting base.
3. The current-transformer mounting base must include termination bolts, Bellevue washers, and nuts on the line and load sides necessary to connect the current transformers. See [Section 9](#) for details about these internal components.
4. One set (i.e., one conductor per phase) of service-entrance conductors must enter the current-transformer cabinets either at or within 2 inches of the top and leave the cabinet either at or within 2 inches of the top or bottom of the opposite end of the cabinet **or** enter and exit at or within 2 inches of the same end of the cabinet. **Applicants must ensure that the conductors are routed carefully when using this option.**
5. Applicants must ensure that cabinets meet the following requirements.
 - All panels and covers must be sealable and all securing screws must be captive.
 - Outdoor CT cabinets are weatherproof.
 - A neutral is bonded to the enclosure.
 - CT cabinets are **not** used as splicing chambers and CTs are **not** tapped off to supply other meters or used for any other purposes.

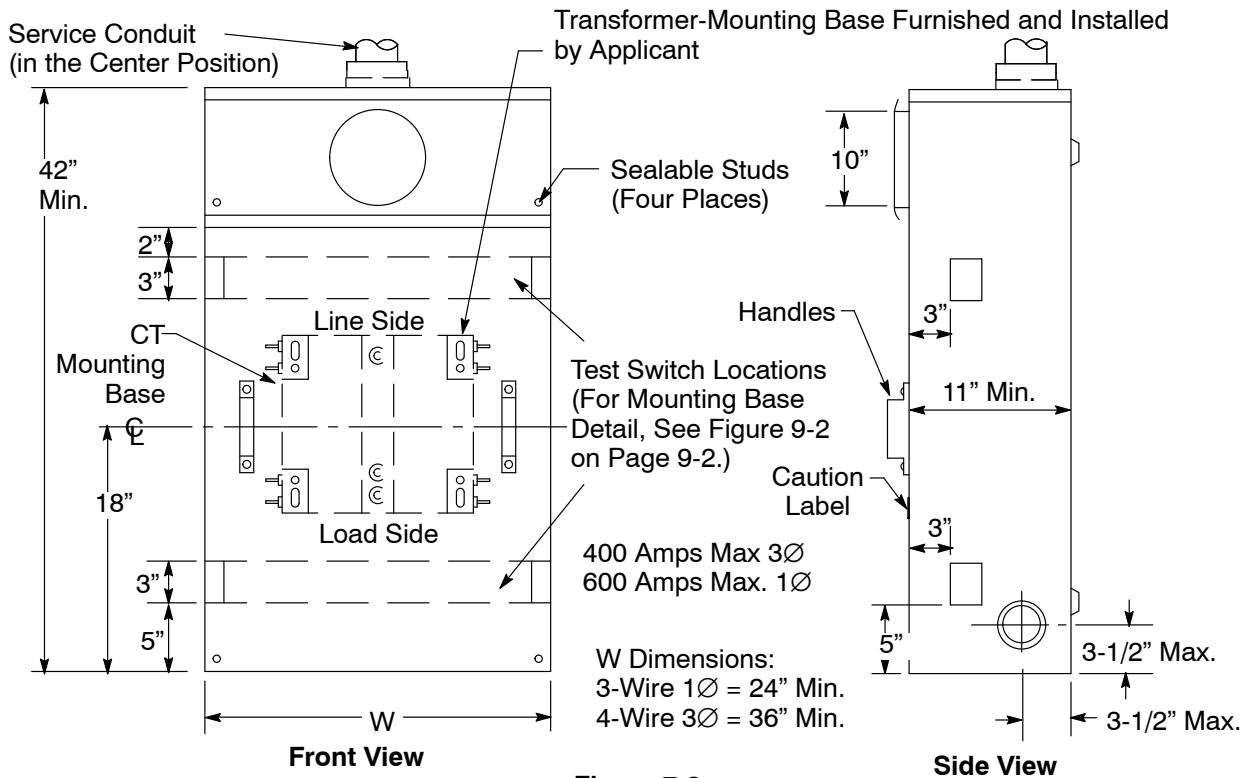

Figure 7-8
Overhead-Fed Combination Meter and Current-Transformer Cabinet,
(201 Amps–400 Amps, 3Ø and 201 Amps–600 Amps, 1Ø)

B. Services, 201 Amps Through 400 Amps, Three Phase, and 201 Amps Through 600 Amps, Single Phase, Current-Transformer Metering

1. When installing a single, overhead, single-phase or three-phase service using current transformers, applicants must furnish, install, and maintain separate current-transformer cabinets and meter boxes, as illustrated in Figure 7-9, “Overhead-Fed, Separate-Bused, Current-Transformer Cabinet and Safety-Socket Meter Box (201 Amps–400 Amps, 3Ø, and 201 Amps–600 Amps, 1Ø),” on Page 7-12. Also required are service-entrance conductors, conduit, and weatherhead to the point of attachment to PG&E’s overhead service.

NOTE: See [Section 9](#), for details about internal components.

2. Applicants must install one set (i.e., one conductor per phase) of conductors before PG&E installs the current transformers. Also applicants must connect the service-entrance conductors to the line and load sides of the current-transformer mounting bus bars.
3. The current transformer bus bars must include termination bolts, Belleville washers, and nuts on the line and load sides necessary to connect the current transformers. See [Section 9](#), for details about these internal components.

4. One set (i.e., one conductor per phase) of service-entrance conductors must enter current-transformer cabinets either at or within 2 inches of the top or bottom and leave the cabinet either at or within 2 inches of the top or bottom of the opposite end of the cabinet **or** enter and exit at or within 2 inches of the same end of the cabinet. **Applicants must ensure that the conductors are routed carefully when using this option.**

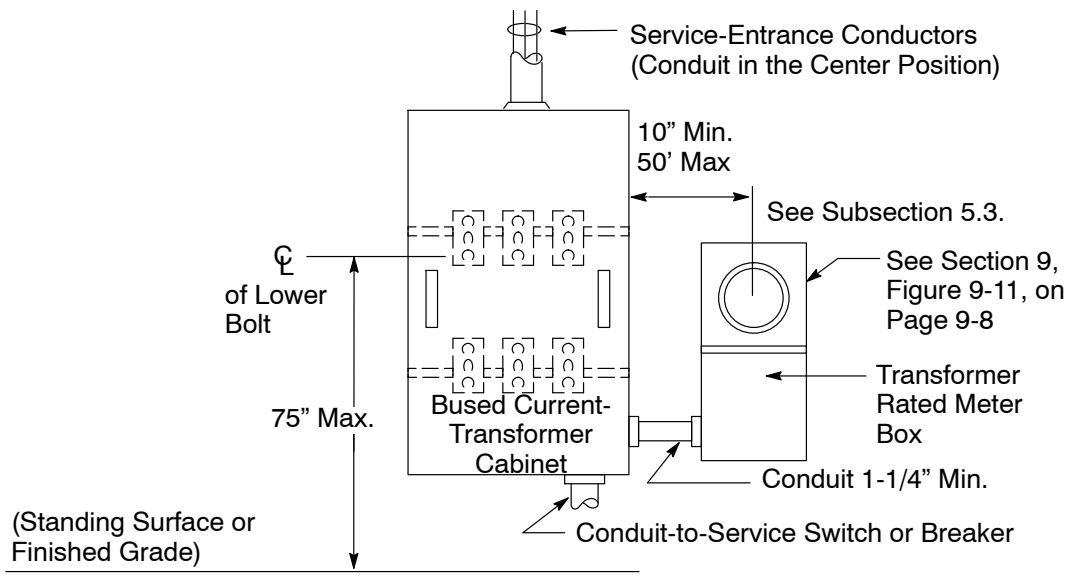

Figure 7-9
Overhead-Fed, Separate-Based, Current-Transformer Cabinet and
Safety-Socket Meter Box (201 Amps–400 Amps, 3Ø, and 201 Amps–600 Amps, 1Ø)

C. Services, 201 Amps and Above, Current-Transformer Metering in Switchboard Service Sections

1. When installing a single, overhead service using current transformers, applicants must furnish, install, own, and maintain a switchboard service section with provisions for the overhead service termination.
2. Typical switchboard service-section arrangements are illustrated in Figure 7-10, “Overhead, Service-Termination, Standard Switchboard Service Section (0 Volts–600 Volts),” on Page 7-13.

NOTE: See [Section 10](#) for details.

3. Applicants must furnish and install service-entrance conductors and either cable or bus bars, as described below.
 - When switchboards are served through bus-bar conductors, the conductors must enter through the top or at the side or back in the upper 10-inch section.
 - When switchboards are served through cable conductors, the conductors must enter through the top of the switchboard. Figure 7-10, on Page 7-13, illustrates an extension that allows for horizontally incoming conduits from the side or rear of the standard switchboard service section.
4. Applicants must ensure that the service-entrance conductors feed from top to bottom. Load conductors must leave **below** the metering compartment barrier. Applicants must ensure that service entrance conductors are connected to the busing in the service sections with lugs approved for the type of conductors used.

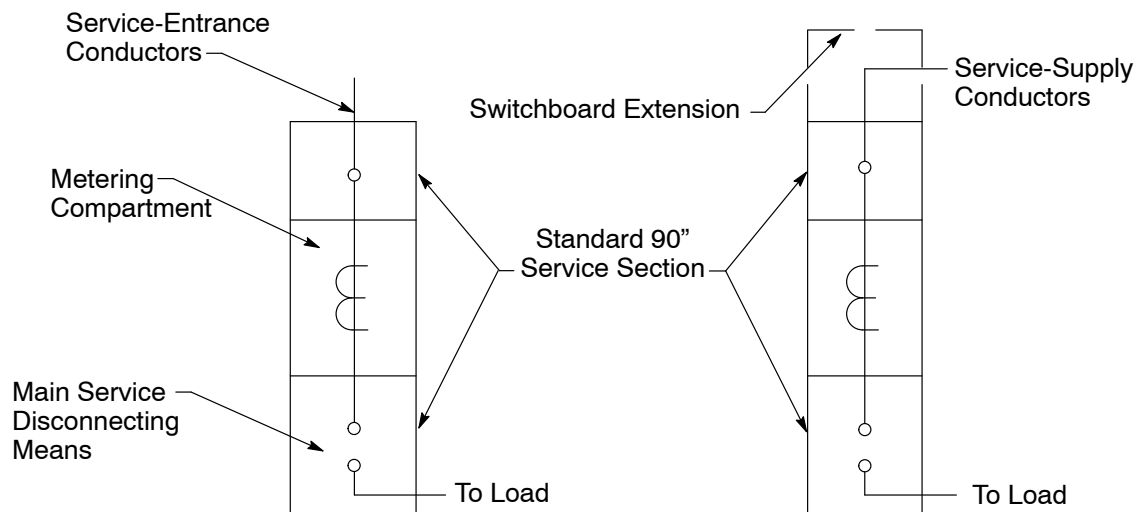

Figure 7-10
Overhead, Service-Termination, Standard Switchboard Service Section
(0 Volts-600 Volts)

7.2.8. Multi-Applicant Meter Installations

Applicants must meet the following requirements when installing multi-applicant meters.

- A. Applicants must install grouped meters for multi-applicant buildings where each occupant is metered individually.
- B. Each unit of a multi-applicant installation must be considered a single applicant and must meet the metering requirements described in Subsection 7.2.5., “Services, 0 Amps Through 200 Amps, Single Applicant, Overhead and Underground,” on Page 7-3.

- C. Applicants must ensure that service entrance conductors for multi-applicant installations extend from PG&E's service termination point to the line side of the meter socket jaw of each socket.
- D. Applicants must ensure that the minimum centerline spacings between meter sockets are 7-1/2 inches horizontal and 8-1/2 inches vertical.
NOTE: PG&E provides and installs nonconductive, meter-socket, blank-off covers before energizing meter panels with vacant meter sockets. PG&E will **not** energize meter panels and sockets unless blank-off meter covers are installed.
- E. For multimeter installations, PG&E determines the ampacity rating of a grouped multimeter installation using one of the following two methods.
 - 1. For installations **without** a main switch or breaker, the service rating will be the rating of the electrical enclosure or service-termination section, pull can, or other service-termination enclosure where PG&E terminates and connects its supply facilities and conductors. Also, see Subsection 1.14.B., on Page 1-12.
 - 2. For installations **with** a main switch or breaker, the rating of the service to be supplied is the rating of the termination section, pull can, service section, or main service switch continuous current rating (typically whichever is greater). Also, see [Section 1](#), "General," Subsection 1.14.A., on Page 1-12.
- F. When a sealable gutter protrudes beyond the meter-mounting surface by more than 4 inches, applicants must maintain 10 inches of clearance from the centerline of the meter face. Otherwise, applicants must have a minimum 4-1/4 inches of vertical clearance.

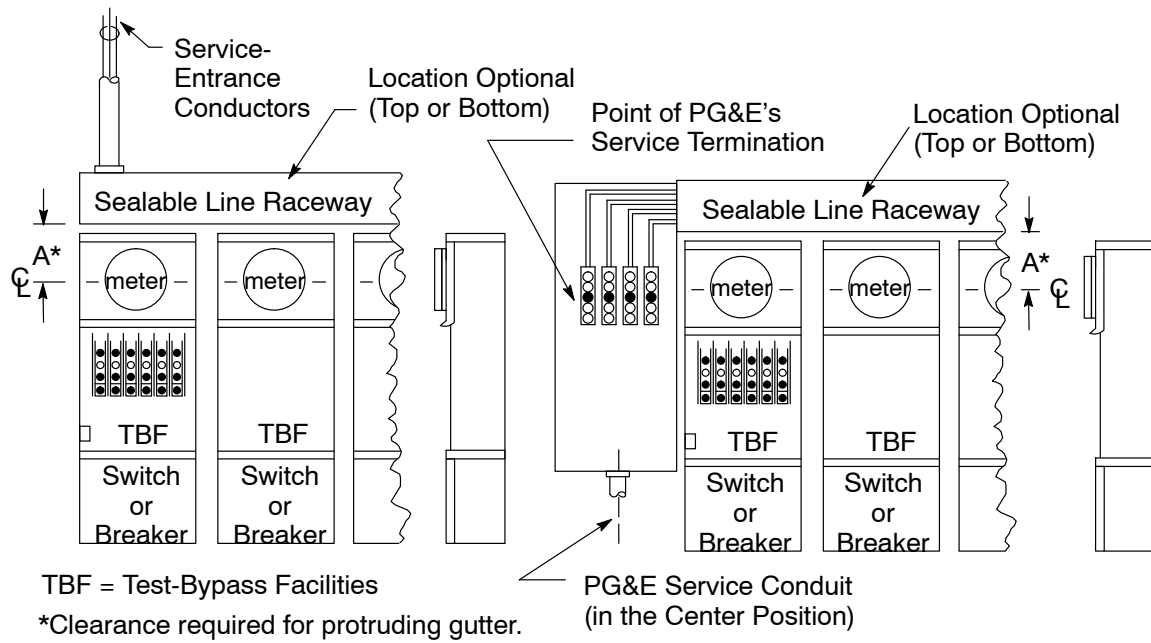

Figure 7-11
Overhead Service, Grouped-Meter
Installation Without a Main Switch

Figure 7-12
Underground Service, Grouped-Meter
Installation Without a Main Switch

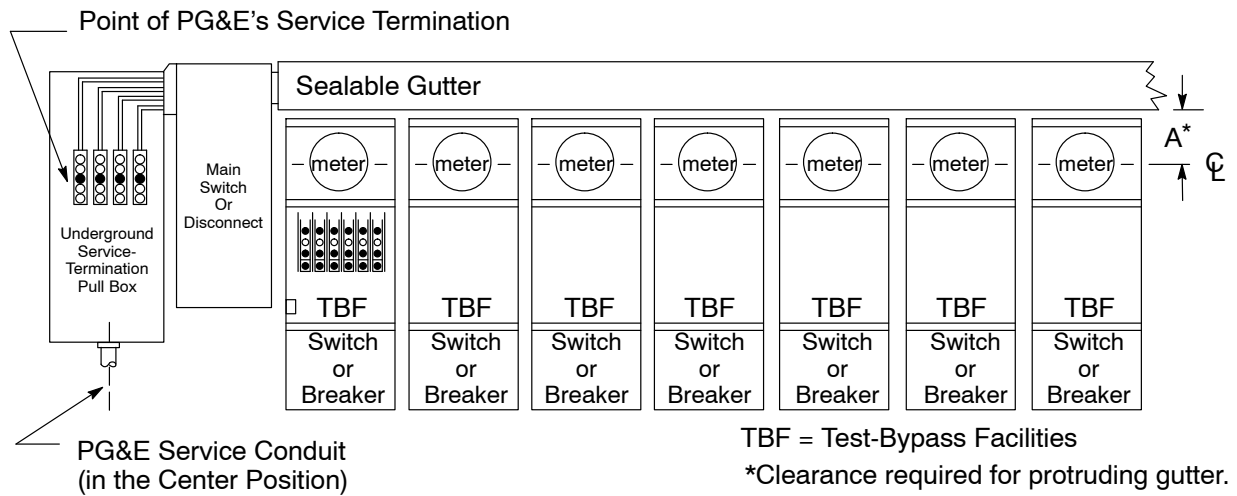

Figure 7-13
Grouped-Meter Installation With a Main Switch

This Page Intentionally Left Blank

**SECTION 8
ELECTRIC METERING:
DIRECT ACCESS**

SECTION 8 ELECTRIC METERING: DIRECT ACCESS

Section 8 Electric Metering: Direct Access

8.1. Scope

Requirements for Section 8, “Electric Metering: Direct Access,” are based on [California Public Utilities Commission \(CPUC\)](#) decisions, including [Electric Rule 22](#), “Direct Access,” and Pacific Gas and Electric Company’s (PG&E’s) [Direct Access Standards for Metering and Meter Data \(DASMMD\) in California](#), filed with the [CPUC](#) on March 1, 1999, as described in Decision 98-12-080.

This Page Intentionally Left Blank

SECTION 9
ELECTRIC METERING:
COMPONENTS

SECTION 9 ELECTRIC METERING: COMPONENTS

Section 9

Electric Metering: Components

9.1. Scope

This section of the manual provides detailed information on individual electric metering components and equipment that Pacific Gas and Electric Company (PG&E) finds acceptable for use in electric metering construction projects.

The [*Electric Utilities Service Equipment Requirements Committee \(EUSERC\)*](#) book, Section 300, contains service and meter-equipment details for PG&E-approved components, as well.

9.2. Test Blocks for Self-Contained Metering, 0 Amps Through 225 Amps

A test block is a specific type of test-bypass **device**. A test block differs from a test-bypass **facility**, which is any mechanism used to bypass meter sockets. Both test blocks and test-bypass facilities are used for self-contained metering exclusively.

Applicants must ensure that test blocks meet the following requirements.

- A. The hex nut must measure 5/8-inch across flats with a copper washer attached. The hex nut must de-energize the meter socket when backed off.
- B. Stud A, located at each conductor terminal, is used to bypass the applicant's load current. Applicants must ensure that these studs are used as described in the following three bullets.
 - Stud A must be located in the clear area between the terminating lug and the circuit-closing nut.
 - Stud A may be positioned on the terminal body, on the terminal screw, or on the bus member.
 - Stud A may be incorporated as part of the wire stop.
- C. Terminals must be aluminum-bodied and suitable for copper and aluminum conductors. The terminal screw may be an Allen type, 3/16-inch across flats for 100-ampere meters, or 5/16-inch across flats for 200-ampere meters.
- D. If Stud A is a part of the terminal screw, the terminal screw must be a 5/8-inch hex.

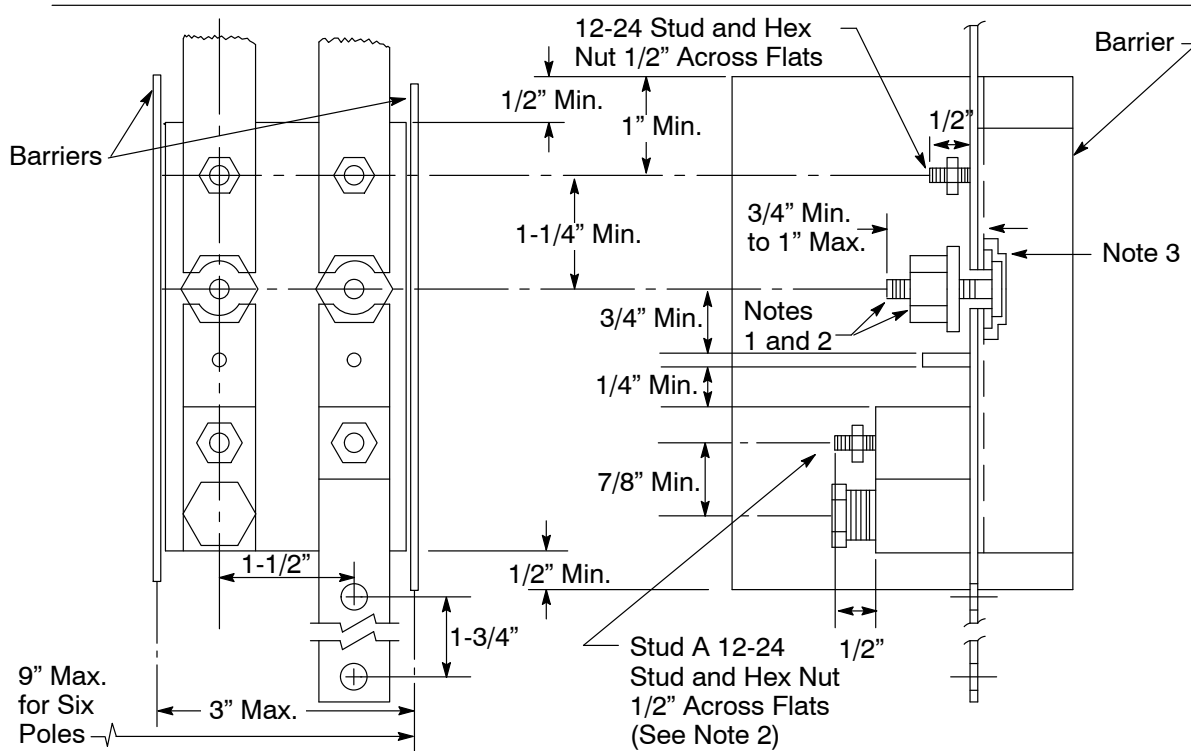

Figure 9-1
Test Blocks for Self-Contained Metering, 0 Amps-225 Amps

Notes in reference to Figure 9-1.

1. A hex nut (i.e., 5/8-inch across flats with a copper washer attached) de-energizes the meter socket when backed off.
2. Stud A, located at each conductor terminal, permits PG&E to bypass the applicant's load current. Locate Stud A in the clear area between the terminating lug and the circuit-closing nut. Stud A may be positioned on the terminal body, on the terminal screw, on the bus member, or incorporated as part of the wire stop.
3. Terminals must be aluminum-bodied and suitable for copper and aluminum conductors. The terminal screw may be an Allen-type (i.e., 3/16-inch across flats for 100-amp meters or 5/16-inch across flats for 200-amp meters). If Stud A is a part of the terminal screw, the terminal screw must be a 5/8-inch hex.
4. **Do not use** an automatic bypass or manual lever bypass. These types of test blocks are not allowed.

9.3. Test Switch Mounting Base Detail

Figure 9-2, below, shows the base dimensions for mounting a removable test switch.

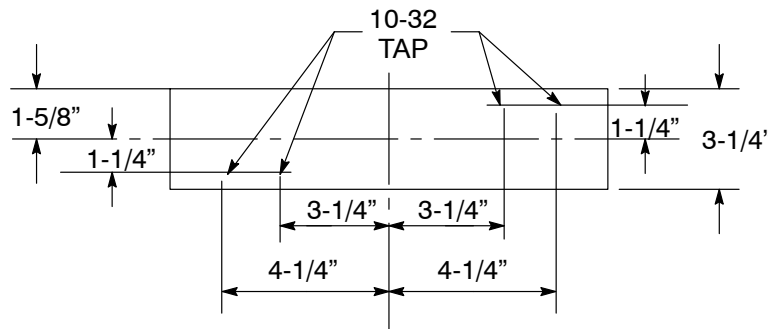
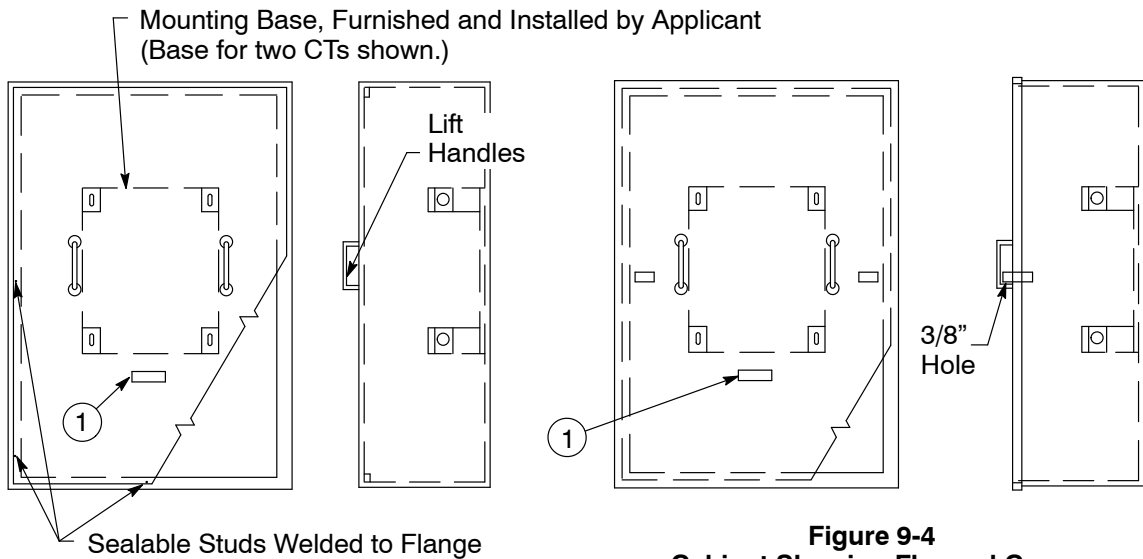

Figure 9-2
Removable Test Switch Mounting-Base Detail

9.4. Separate CT Cabinet, 201 Amps and Above, Single Phase and Three Phase

Applicants must ensure that cabinets meet the following requirements.

- A. All covers are sealable.
- B. Outdoor current transformer (CT) cabinets are weatherproof.
- C. Grounding lugs are provided.
- D. CT cabinets are **not** used as splicing chambers.
- E. CTs are **not** tapped off to supply other meters or used by applicants for any other purposes.
- F. PG&E’s underground service-lateral conductors do **not** terminate in CT cabinets.



**Figure 9-3
Cabinet Showing Stud-Mounted Cover**

**Figure 9-4
Cabinet Showing Flanged Cover
Fastened by Sealable Rivet Latches**

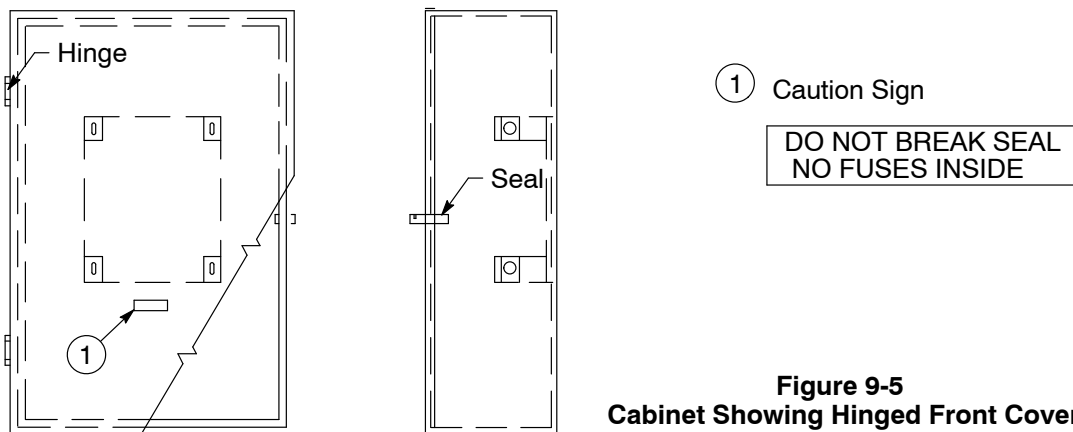

**Figure 9-5
Cabinet Showing Hinged Front Cover**

Table 9-1 CT Cabinet Minimum Dimensions

Type of Service	Cabinet Size (in Inches)	CT Mounting Base	CT Cabinet
3-Wire, 1Ø	24w x 48h x 12d	Figure 9-6	Figure 9-8
4-Wire, 3Ø	36w x 48h x 12d	Figure 9-7	Figure 9-9

9.5. CT Mounting Base, 201 Amps Through 400 Amps

Applicants must ensure that all of the required lugs are furnished and that conductors are connected to the line and load terminals on the CT mounting base. Also, applicants must ensure that the power leg conductor for a 4-wire delta service is marked clearly. The power leg is identified by using the color orange.

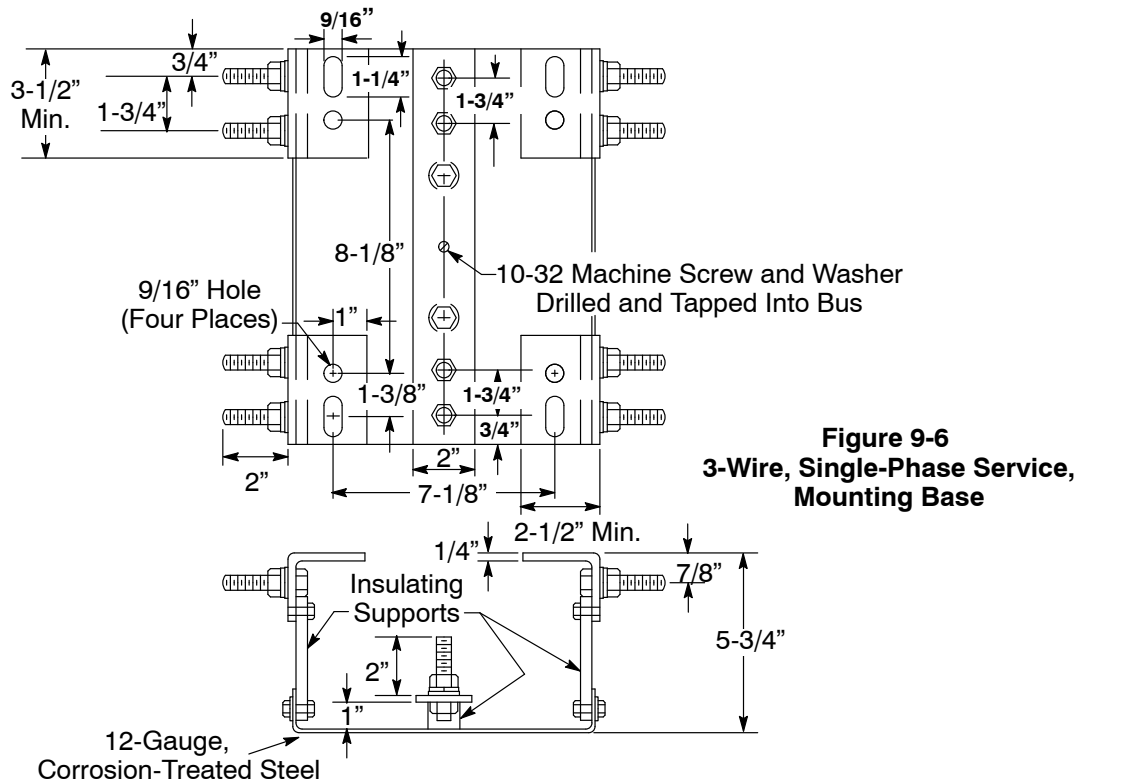

Figure 9-6
3-Wire, Single-Phase Service,
Mounting Base

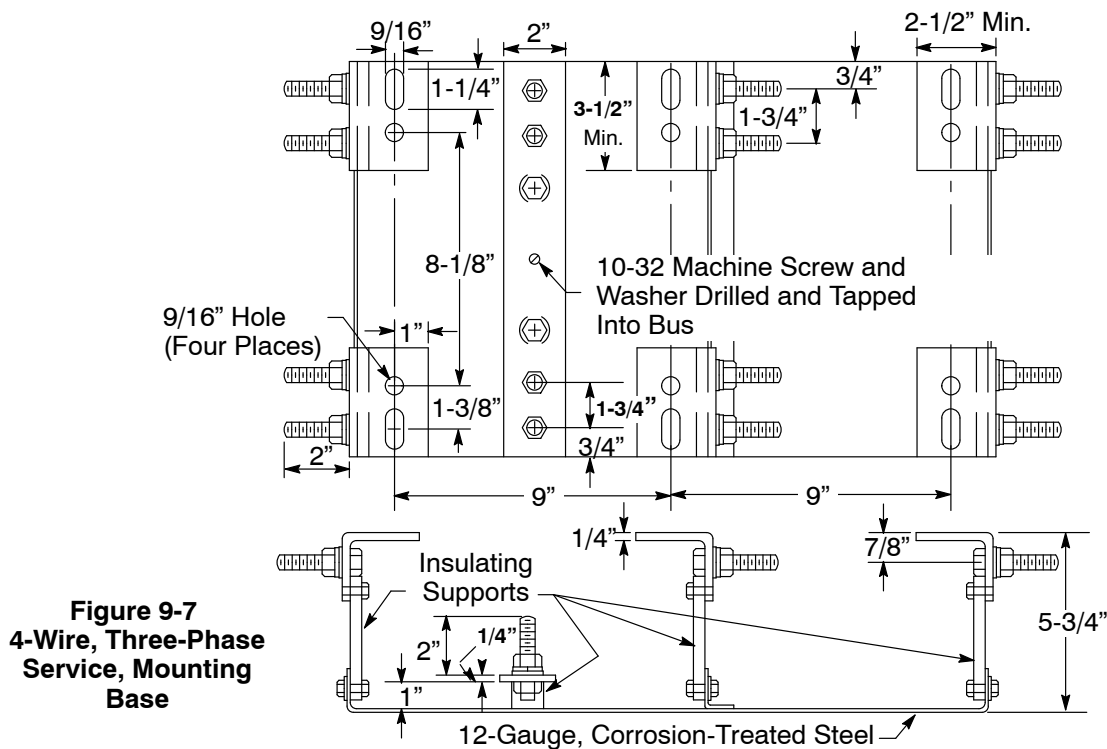

Figure 9-7
4-Wire, Three-Phase
Service, Mounting
Base

9.6. Alternate CT Mounting Base, 3-Wire, One Phase or Three Phase

Applicants must ensure that mounting bases meet the following requirements.

- A. Insulated supports are rated for the serving voltage and have sufficient mechanical strength for the application.
- B. Mounting bases accept bar-type CTs only.
- C. Two 1/2-inch steel, Grade 5 bolts are provided for each cable-terminating and CT-mounting position. Each bolt must be furnished with a 2-1/4-inch diameter Belleville washer and a nut. Bolts must be secured in place and spaced as shown in Figure 9-6, “3-Wire, Single-Phase Service, Mounting Base,” on Page 9-4. All parts must be plated to prevent corrosion.

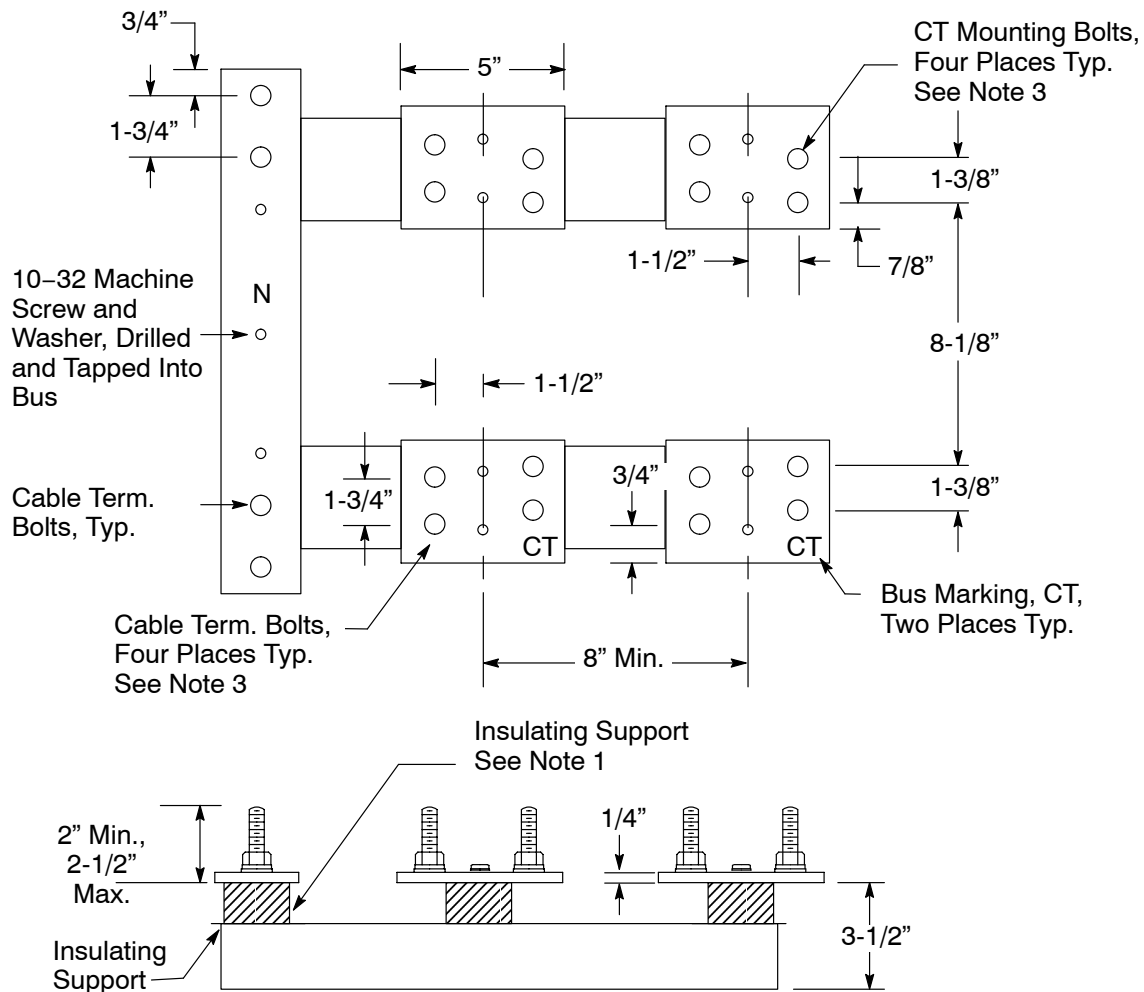

Figure 9-8
CT Mounting Base (Single-Phase or Three-Phase, 3-Wire,
201 Amps–600 Amps, 0 Volts–600 Volts)

Notes in reference to Figure 9-8.

1. Insulated supports must be rated for the serving voltage and have sufficient mechanical strength for the application.
2. The mounting base accepts bar-type CTs only.
3. Two 1/2-inch steel, Grade 5 bolts must be provided for each cable-terminating and CT mounting position. Each bolt must be furnished with a 2-1/4-inch diameter Belleville washer and a nut. Bolts must be secured in place and spaced as shown. All parts must be plated to prevent corrosion.

9.7. Bused CT Cabinet, 3-Wire Service, 201 Amps Through 800 Amps

Applicants must ensure that cabinets meet the following requirements.

- A. All covers are sealable.
- B. Outdoor CT cabinets are weatherproof.
- C. Grounding lugs are provided.
- D. Neutral or unmetred wiring, either cable or bus bar, is located on either side of the cabinet.
- E. CT cabinets are **not** used as splicing chambers.
- F. PG&E's underground service lateral conductors do **not** terminate in CT cabinets.

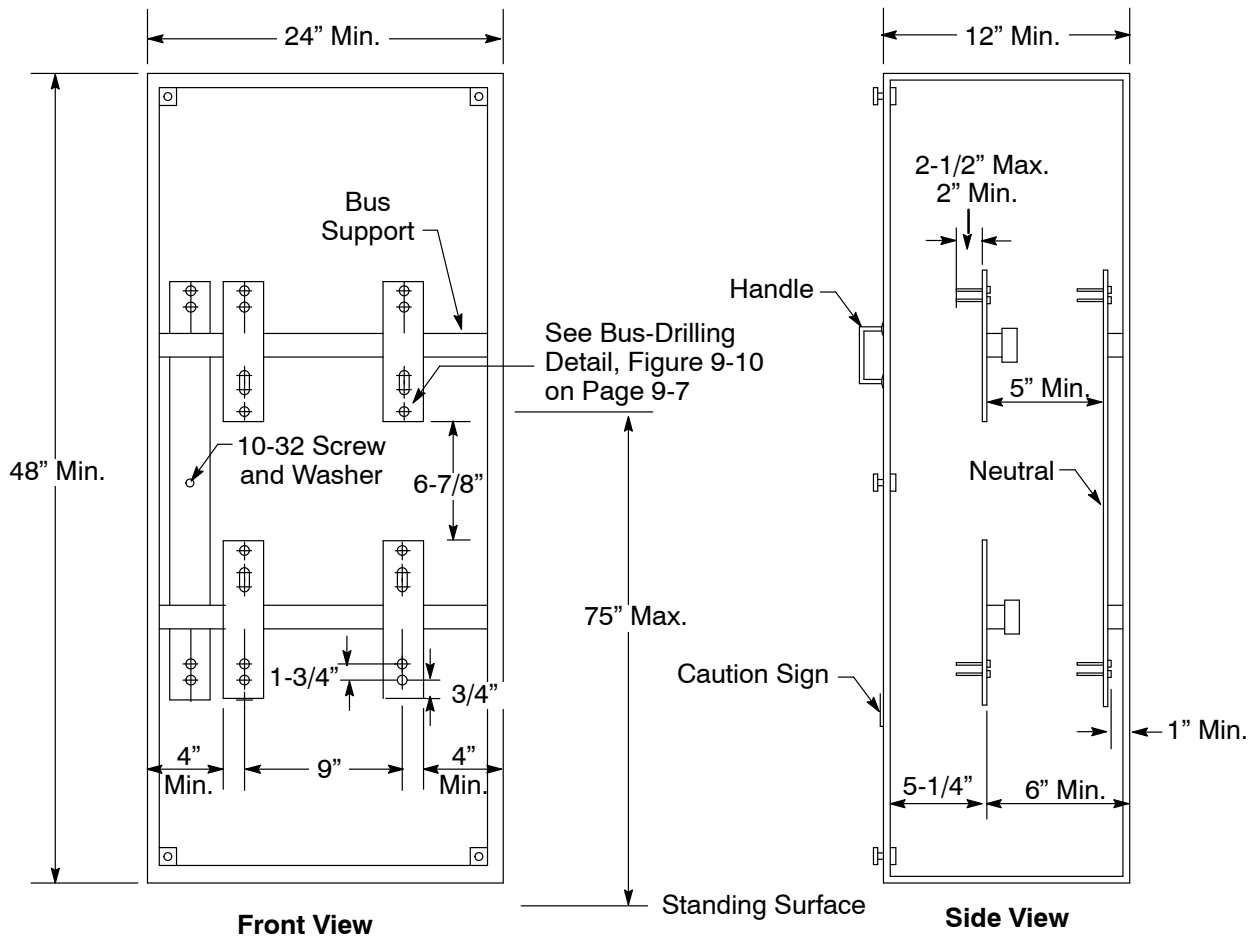

Figure 9-9
Bused CT Cabinet, 3-Wire Service, 201 Amps–800 Amps

9.8. Bused CT Cabinet, 4-Wire Service, 201 Amps–800 Amps

Applicants must ensure that cabinets meet the following requirements.

- A. All covers are sealable.
- B. Outdoor CT cabinets are weatherproof.
- C. Grounding lugs are provided.
- D. Neutral or unmetred wiring, either cable or bus bar, is located on either side of the cabinet.
- E. CT cabinets are **not** used as splicing chambers.
- F. PG&E’s underground service lateral conductors do **not** terminate in CT cabinets.

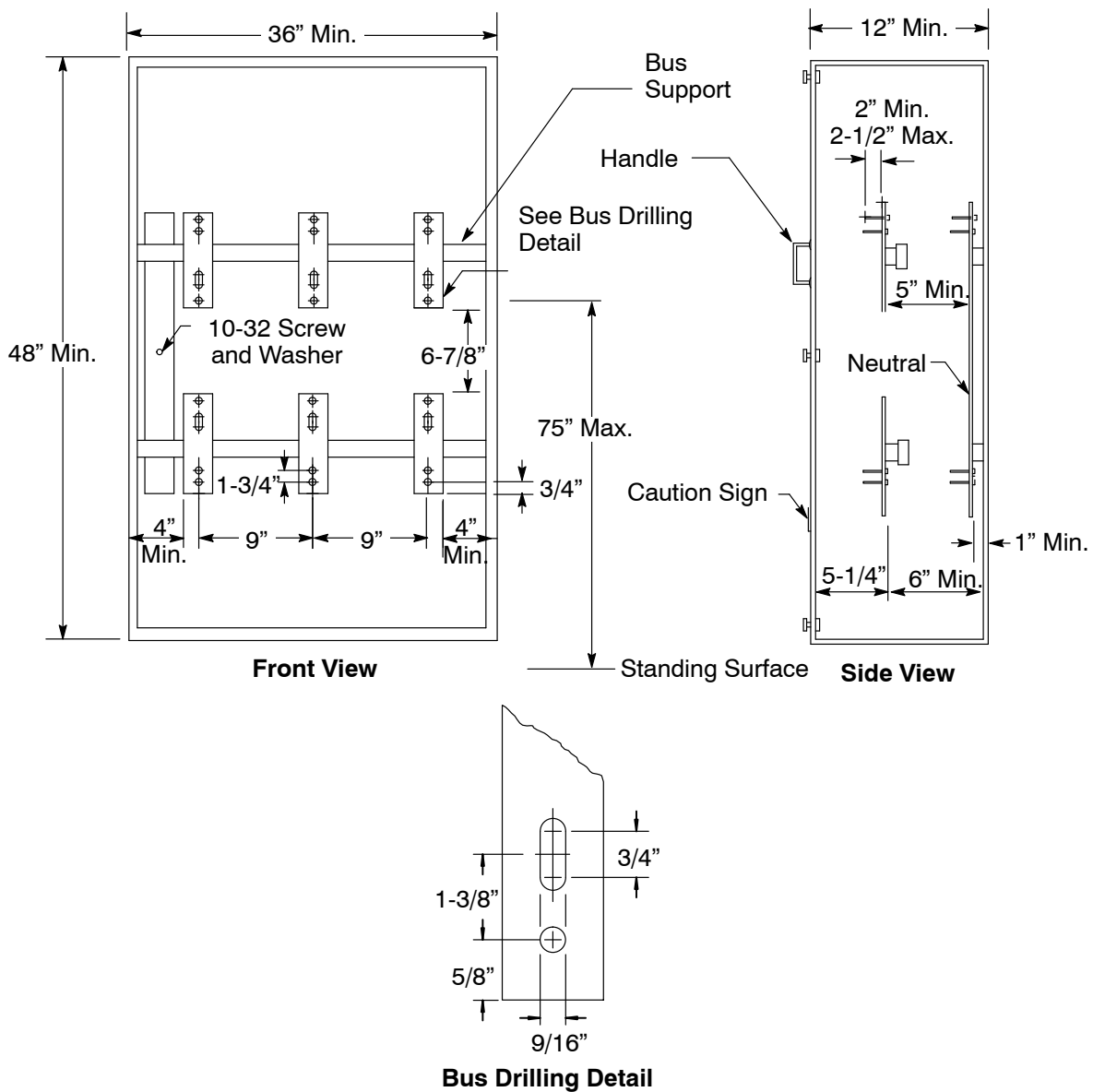

Figure 9-10
Bused CT Cabinet (4-Wire Service, 201 Amps–800 Amps)

9.9. Meter Box for Transformer-Rated Metering

Applicants must ensure that meter socket jaw requirements and connections are made according to the rules in [Section 5](#), “Electric Metering: General,” Subsection 5.6., on Page 5-17.

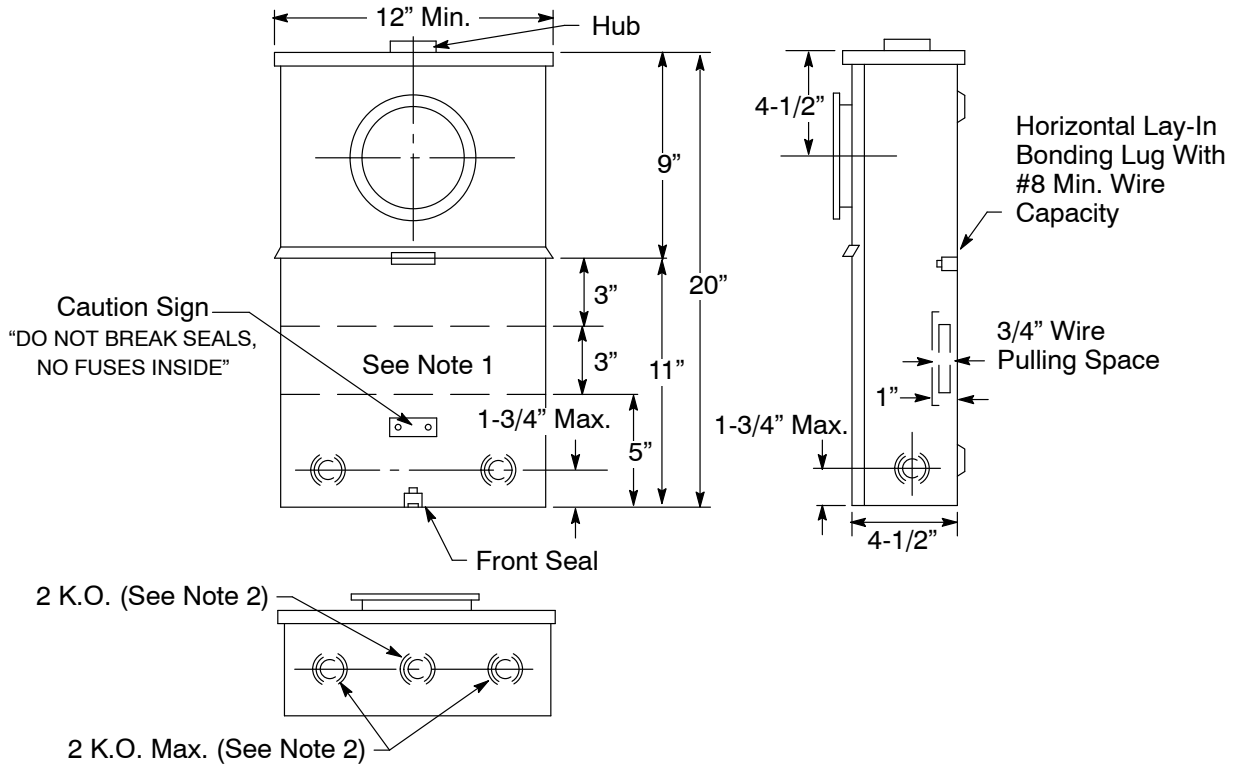

Figure 9-11
Meter Box for Transformer-Rated Metering
(Single-Phase or Three-Phase Installations)

Notes in reference to Figure 9-11.

1. Location of mounting bracket for test switch or reactive transformer.
2. K.O.—knock out

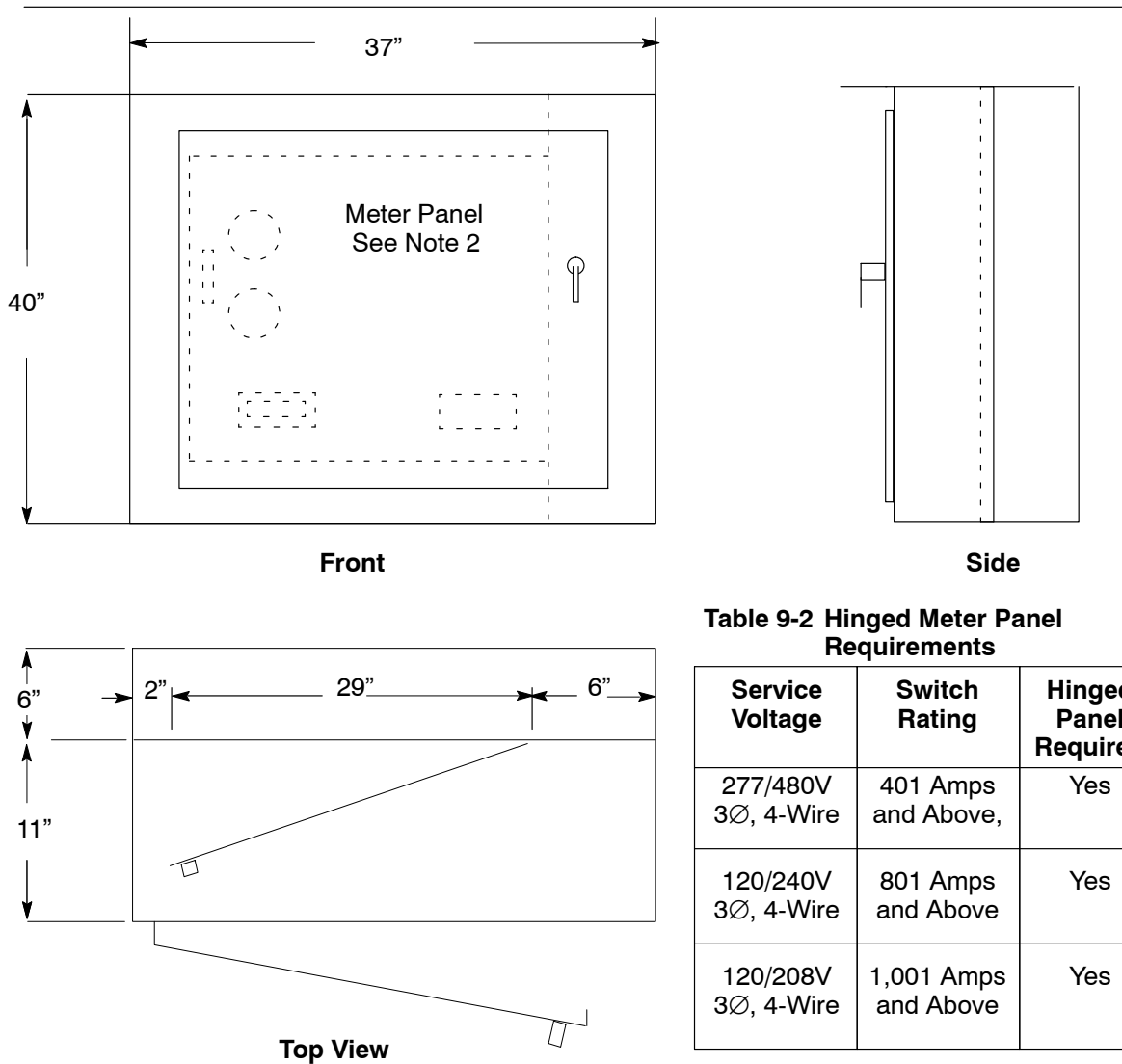

Figure 9-12
Remote Metering Cabinet (Three-Phase Installations)

Notes in reference to Figure 9-12.

1. The enclosure must be:
 - a. Equipped with a device to secure the door in the open position at 90° or more.
 - b. Secured in the closed position with a handle-operated latching mechanism, and lockable with a padlock having a 5/16" lockshaft.
2. For meter panel requirements, see Figure 10-28, "Standard Switchboard Service Section, 30-Inch Panel for Socket Meters and Recorder," on Page 10-37.
3. Written information must be provided and marked inside of the meter panel. This information must include:
 - a. Potential Transformer/Current Transformer (PT/CT) designation (Type)
 - b. Rating Factor (RF)
 - c. Burden
4. Remote metering must be approved by the the local meter shop before installation.
5. See Table 9-2, "Hinged Meter Panel Requirements," above.

9.10. Underground Service Cable-Termination Section or Pull Box

Applicants must ensure that underground service-termination sections or pull boxes meet the following requirements.

- A. Pull box covers must be removable, sealable, provided with two lifting handles, and limited to a maximum size of 9 square feet.
 - B. The panel can be sealed using two drilled stud-nut and wing-nut assemblies on opposite sides of the panel.
 - C. The minimum dimensions specified in Table 9-3, “Minimum Wall-Mounted Pull-Section Dimensions: Residential and Nonresidential, Single-Phase or Three-Phase,” on Page 9-11, are used when the service conduit enters the bottom of the termination compartment or pull box and all load conductors exit above the terminals. When the service conduit enters from the side or back of the pull box, use the X dimensions from the closest portion of the conduit to the nearest termination bolt.
 - D. A PG&E project coordinator is contacted when developing nonresidential, 401-amps-and-above services. Applicants must ensure that they meet PG&E’s requirements for underground service-termination pull boxes, which include the following:
 - 1. Installing multiple sets of utility service cables.
 - 2. Provide stacking lug provisions to terminate cables in any three-phase installation that is 1,200 amps or greater.
 - 3. Providing additional space (i.e., depth, width, and termination height), when required, in any section of switchboard, panel board, or other enclosure intended as a termination point for PG&E’s service cables. This additional space will provide the mandatory clearances between phases and grounded surfaces, as well as accommodate the installed service cables.
- See [Numbered Document 063928](#), “Methods and Requirements for Installing Commercial Underground Electric Services 0–600 Volts to Customer-Owned Facilities,” for the appropriate conduit and cable requirements to use when designing nonresidential service installations. This document is included in [Appendix C](#), “Electric and Gas Engineering Documents.”
- E. Applicants must not use wall-mounted cable-termination and pull enclosures for three-phase, nonresidential installations rated 401 amps through 2,500 amps. See Table 9-4, “Minimum Pad-Mounted (Floor-Standing) Switchboard Pull-Section Dimensions: Residential and Nonresidential, Single-Phase and Three-Phase,” on Page 9-11, and Table 10-1, “Minimum Bottom-Fed Pull Section Dimensions,” on Page 10-24, for bottom-entry installation requirements. See Table 10-2, “Pull Section Dimensions (Minimums) Below Ground Level,” on Page 10-27, for side-entry or back-entry requirements.
 - F. See additional requirements for pad-mounted switchboards in Section 10.3.14., “Underground, Cable-Terminating Facilities in Pull Boxes or Pull Sections,” on Page 10-29. The information and figures describe additional requirements for applicants who install these facilities.

Table 9-3 Minimum Wall-Mounted Pull-Section Dimensions: Residential and Nonresidential, Single-Phase ¹ or Three-Phase ¹

Service Rating (Amps)	Minimum Access Opening "W"		X		Y	
	3-Wire	4-Wire	Bottom Entry	Side/Rear Entry	Bottom Entry	Rear Entry
	All Measurements in Inches					
0–225 ²	10-1/2	14	11	36	6	15
226–400	10-1/2	14	22	42	6	24
401–600 ³	16-1/2	—	26	48	11	24
Over 600	See Table 9-4, below, for nonresidential, single-phase services over 600 amperes and all three-phase services over 400 amperes.					
601–800 ^{3, 4}	16-1/2	—	26	48	11	24

¹ See "Notes" at the bottom of this page in reference to Table 9-3 and Table 9-4.

² See Table 6-1 for minimum dimensions of residential (combination) meter panels.

³ Single phase only.

⁴ Residential only.

Table 9-4 Minimum Pad-Mounted (Floor-Standing) Switchboard Pull-Section Dimensions: Residential and Nonresidential, Single-Phase and Three-Phase

Service Rating (Amps)	Minimum Access Opening "W"		Termination Height "X"
	3-Wire	4-Wire	
	All Measurements in Inches		
321–400	24	24	42 Min.–72 Max. (see Note 4 below)
401–800	24	24	
801–1,200	24	30	
1,201–2,000	30	35	
2,001–2,500	—	42	60 Min.–72 Max.

Notes in reference to Table 9-3 and Table 9-4.

1. If termination bus-landing stubs are installed perpendicular to the back of the board, a wider enclosure dimension will be required to accommodate the installation of PG&E's cables.
2. Maintain a clear working space. When return flanges are necessary, ensure they do not intrude into service-conductor space.
3. Dimension W is the minimum width of the pull section access opening.
4. The minimum termination height is 40-1/4 inches for Bottom-Fed Service Sections only as shown in Figure 7-7 on Page 7-8 and Figure 10-15 on Page 10-24.

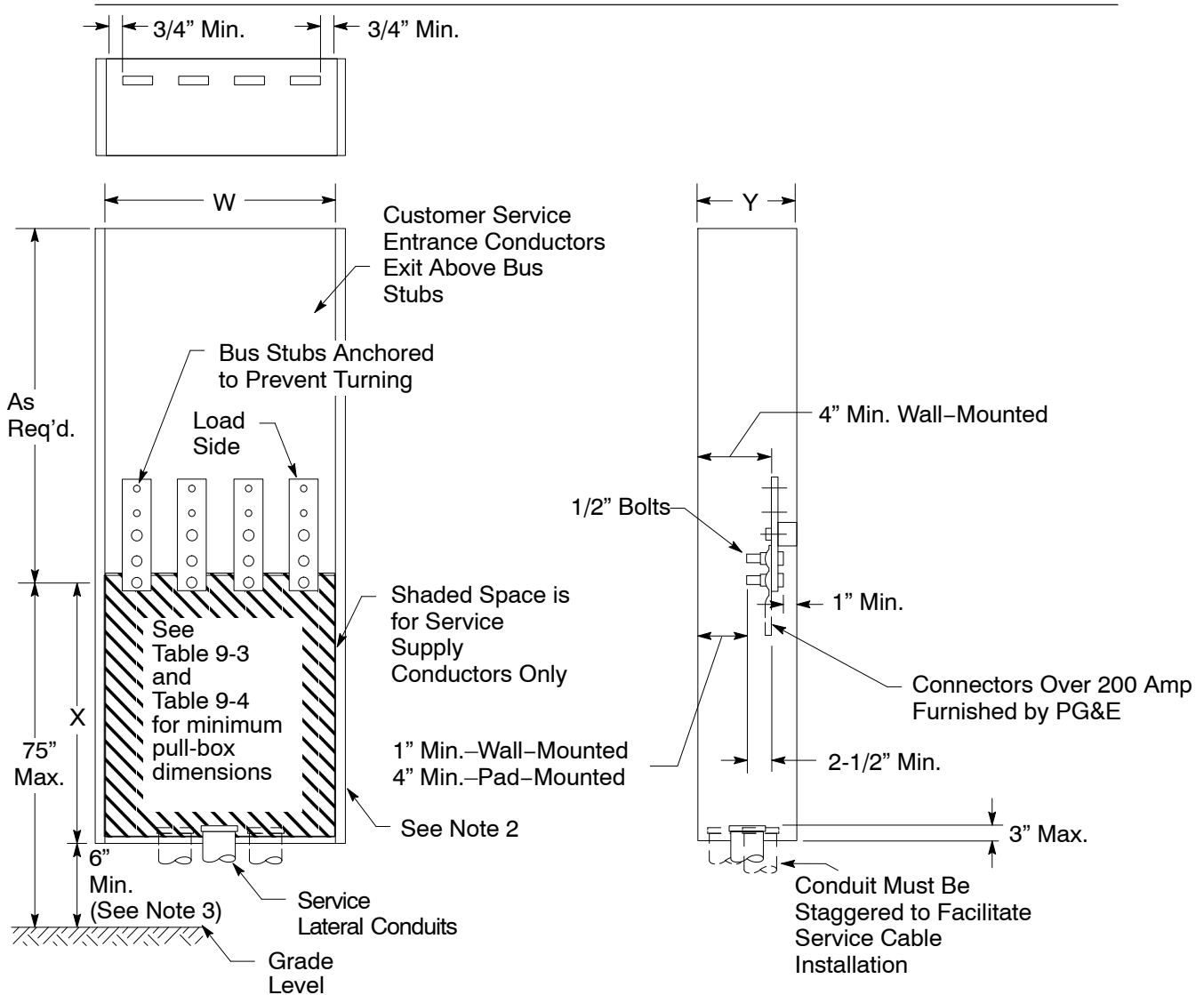

Figure 9-13
Typical Underground Service Termination Section and Pull Box,
Wall-Mounted or Pad-Mounted (Floor-Standing)

Notes in reference to Figure 9-13.

1. Ensure that pull-box covers are removable, sealable, provided with two lifting handles, and limited to a maximum size of 9 square feet. Sealing provisions must consist of two drilled stud-and-wing nut assemblies on opposite sides of the panel. Ensure that all security screws are captive.
2. Maintain a clear working space. When return flanges are necessary, ensure that they do not intrude into service conductor space (designated by shading).
3. The 6-inch minimum height requirement from grade to panel does not apply for a floor-standing switchboard.
4. A main service switch rated at 2,501 amps and above requires bus-duct configuration.

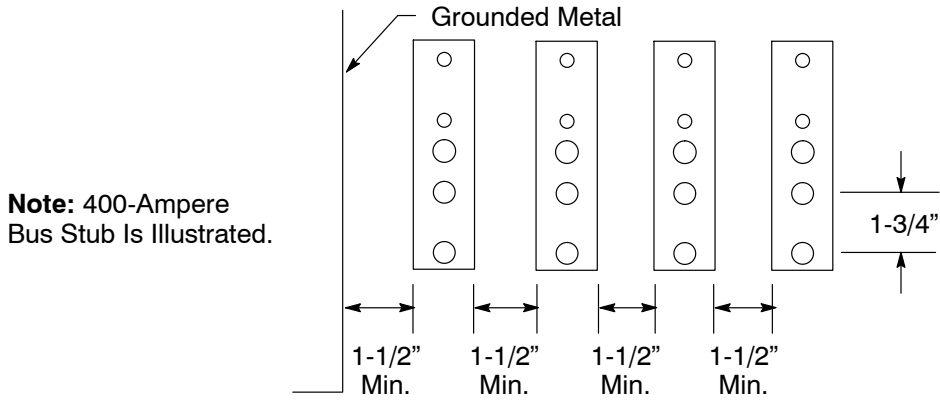

Figure 9-14
Detail of Clearance Requirements for Adjacent Termination Bus Stubs

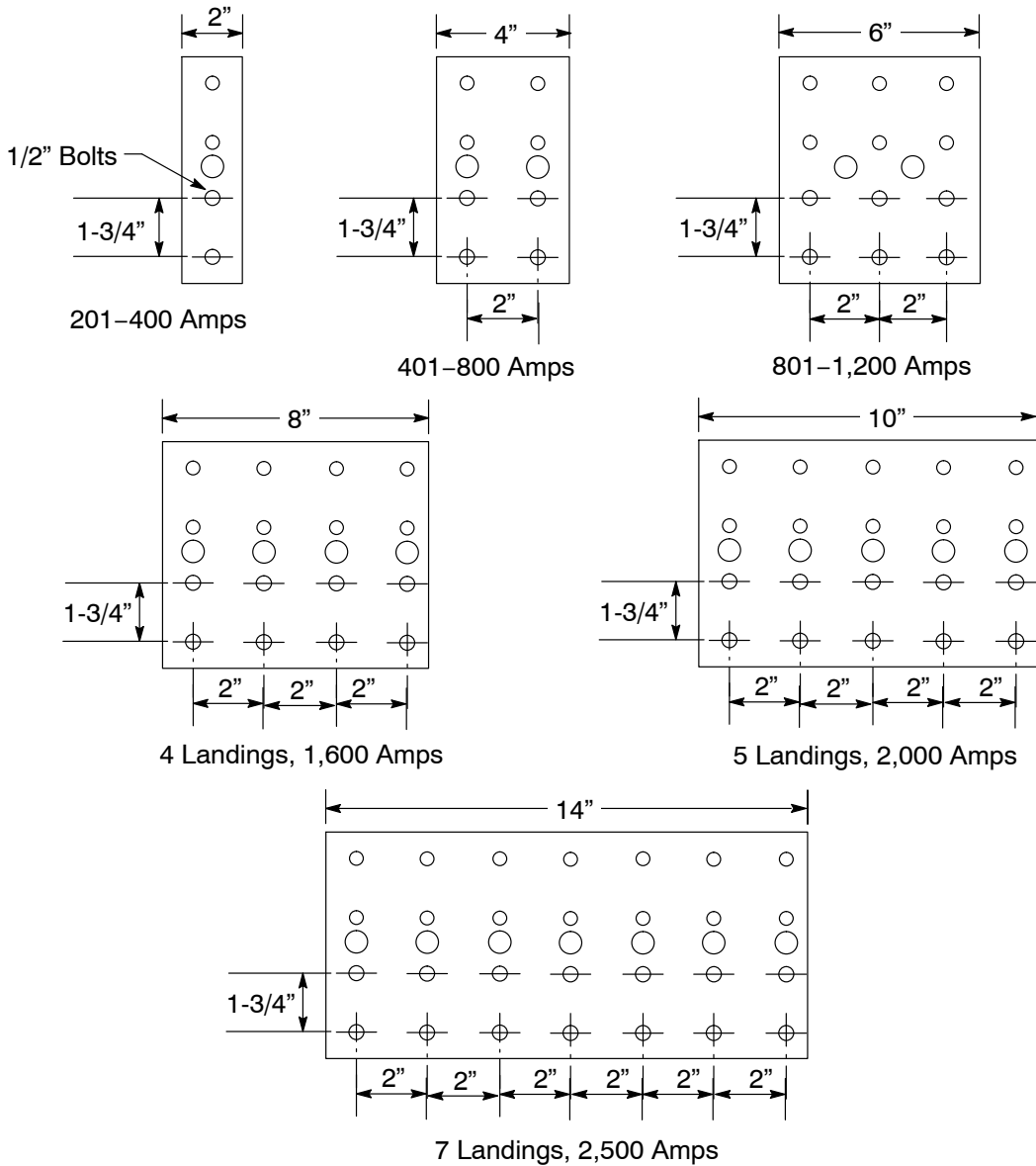

Figure 9-15
Detail of Aluminum, Termination Bus Stubs

9.11. Approved Service-Terminal Conductor Connectors

Applicants must observe the following requirements when they plan to install approved, service-terminal conductor connectors.

- A. Applicants must furnish and install PG&E-approved, range-taking connectors, suitable for aluminum conductors, for enclosures rated at 0 through 225 amps.
- B. PG&E must furnish and install approved, cable-to-flat-bar connectors on the termination bus stub, as specified in Table 9-5, “Approved, Compression-Type Service-Terminal Connectors,” on Page 9-15, for enclosures rated above 225 amps. For a Class 320-amp panel, cable-to-flat-bar connectors on the termination bus stub are preferred; however, 320-amp-rated meter panels with hex lug terminations are acceptable also. See [Numbered Document 058817](#), “Terminating Underground Electric Services 0-600 Volts in Customer-Owned Facilities,” Figure 2 on Page 4.
- C. Applicants **may** use one-bolt, bus attachment connectors for 0- through 225-amp services **if** the connectors are anchored to prevent the connector assembly from twisting.

Applicants must **not** use pin termination connectors to install cables larger than those intended for the range-taking connectors in their service panel or service enclosure.

NOTE: Do **not** peel stranded cables to fit conductors into termination connectors.

See PG&E [Numbered Document 015251](#), “Connectors for Insulated Cables Underground Distribution Systems,” Table 28, “Specifications for Terminal Connectors—Aluminum Cable-to-Flat-Bar,” Page 26 of 44, for more information. This document is included in [Appendix C](#).

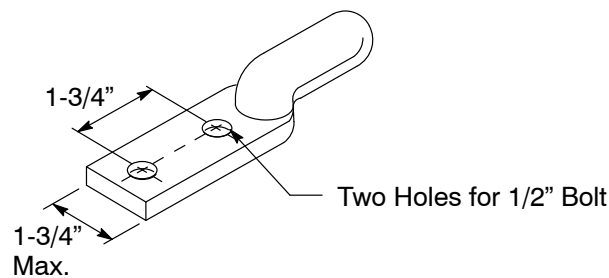

Figure 9-16
Service-Terminal Conductor Connector

Table 9-5 Approved, Compression-Type, Service-Terminal Connectors

Conductor Size: AWG or kcmil	Manufacturer and Catalog Number						Tool Index Number
	Mac	Homac	Burndy	Electrical Specialty	3M Company	Code	
4/0	NLRB4/0-8N	AL-4/0-NTN	YAK28A-2G2	—	—	303759	4/0 AS
	MLB4/0-8N	—	YA28-A5	AHL-4/0-BNTP	40145	—	4/0 A
350	NLRB350-8N	AL-350-NTN	YAK31A-2G2	—	—	303758	350 A
	MLB350-8N	—	YA31-A3	AHL-350-BNTP	40156	—	350 A
700/750	NLRB750-8N	AL-750-NTN	YAK39A-2G2	—	—	303833	700/750 A
	MLB750-8N	—	YA39-AM 2	AHL-750-BNTP	40172	—	700/750 A
1,000	NLRB1,000-8N	AL-1,000-SSN	YAK44A-2NG7	—	—	303834	1,000 A
	MLB1,000-8N	—	YCAK44 A-2G2	AHL-1,000-BNTP	40178	—	1,000 A

9.12. Underground-Service Auxiliary Pull Cabinet

Applicants must observe the following requirements when they plan to install an underground-service auxiliary pull cabinet.

- A. Applicants may use auxiliary pull cabinets when there is more than one 90° turn in a service lateral run that will terminate in an underground service-termination pull box. Applicants must furnish and install auxiliary cabinets.
- B. Applicants must ensure that underground-service auxiliary pull cabinets:
 1. Have suitable grounding lugs and are provided with sealable covers.
 2. Are constructed of sturdy metal.
 3. Are weatherproof.
 4. Have an 11-inch minimum depth. When the available space is not large enough to provide the specified minimum dimensions, ask your local project coordinator to consult with the PG&E electric meter department.

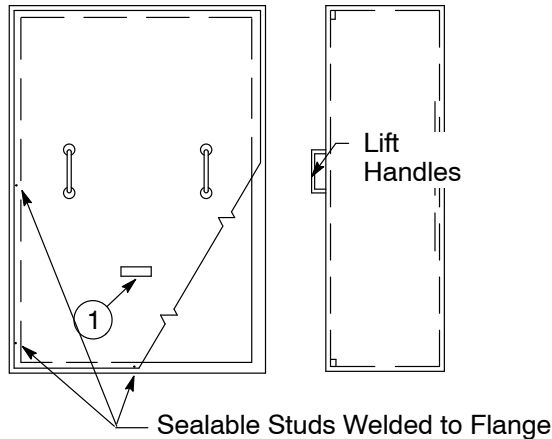

Figure 9-17
Cabinet Showing Stud-Mounted Cover

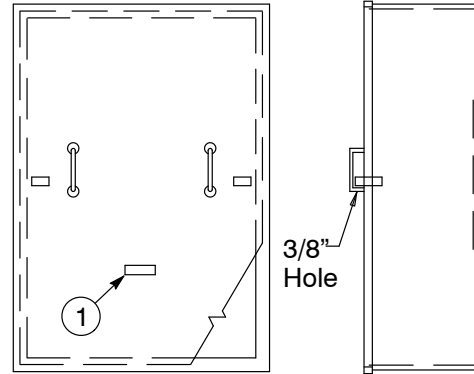

Figure 9-18
Cabinet Showing Flanged Cover
Fastened by Sealable Rivet Latches

① Caution Sign
 DO NOT BREAK SEAL
 NO FUSES INSIDE

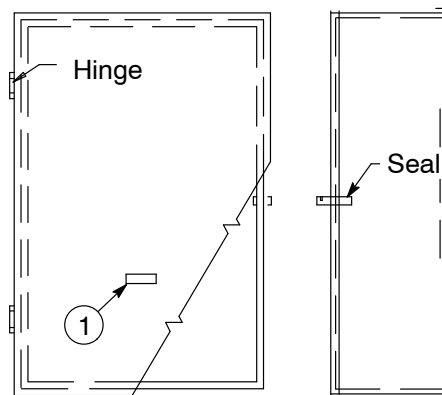

Figure 9-19
Cabinet Showing Hinged, Flanged Cover

Table 9-6 Minimum Connection Cabinet Sizes ¹

Switch Service Capacity (in Amps)	3-Wire Service	4-Wire Service
	All Measurements in Inches	
225	24 x 24	24 x 24
400	24 x 30	24 x 30
600	24 x 30	30 x 36
800	30 x 36	36 x 36

¹ When service is over 800 amps, consult your local PG&E project coordinator.

9.13. Nonresidential Service Pedestals 0 - 200 Amps (EUSERC 308)

Applicants must ensure that nonresidential service pedestals meet the following requirements.

- A. The meter socket is mounted on a support, attached to the meter panel, and provided with a sealing ring. Enclose the meter socket with an enclosing cover that is:
 - 1. Hinged to allow the top and front to be rotated back as one unit to expose the metering compartment. The “A” dimension applies when the meter compartment side panels are fixed in place and obstruct the meter socket side clearance. Ensure that the lifting force required to open the cover does not exceed 25 pounds.
 - 2. Equipped with a lifting handle.
 - 3. Sealable and lockable with a padlock having a 5/16-inch lock shaft.
 - 4. Provided with a demand reset cover with a viewing window. Ensure that the reset cover is sealable and lockable with a padlock having a 5/16-inch lock shaft.
- B. The test-bypass compartment cover:
 - 1. Does **not** exceed a maximum weight of 25 pounds.
 - 2. Has a fixed top and sides that allow access to the metering compartment through a hinged door. The hinged door must be equipped with a device to hold the door open at 90° or more.
 - 3. Is sealable and fitted with a lifting handle.
 - 4. Has two lifting handles if the cover is more than 16 inches wide.
- C. Test-bypass blocks with rigid barriers are furnished, installed, and wired or bused to the meter socket by the manufacturer. Connection sequences must be line-loaded from left to right and clearly identified by block-letter labeling at least 3/4-inch high.

Applicants must ensure that test-bypass facilities are installed with the following clearances.

- 1. Facilities require 3 inches of vertical clearance from the upper test connector stud to the upper compartment access opening.
 - 2. Facilities require 3 inches from the center of the cable terminal screw to the lower compartment access opening.
 - 3. Facilities require 1-1/2 inches of side clearance from the rigid insulating barriers to the compartment sides and 1 inch to the compartment access openings.
- D. Utility compartment covers (i.e., meter covers, demand reset covers, and pull sections) are sealable and lockable using a padlock with a 5/16-inch lock shaft.
- E. Internal equipment attached to the outer walls of the enclosure is secured in place with devices that cannot be loosened from the outside. Do **not** use screws or bolts requiring special tools to install or remove them.

F. The terminating pull-section of the pedestals:

1. Comply with the minimum dimensions illustrated in Table 9-7 on Page 9-19.
2. Accept a minimum 3-inch conduit.
3. Have covers equipped with lifting handles.
4. Are equipped with aluminum-bodied mechanical lugs, ranging from #6 AWG through 250 kcmil, for terminating the service conductors.
5. Have insulated cables or busses installed between the termination lugs and the test-bypass facilities.
6. Have protective metallic barriers, 16-gauge minimum, provided between the pull sections and their (the applicants') distribution sections.
7. Have a 1/4-inch minimum clearance between the applicants' section walls and the barriers to prevent screws and bolts from protruding into the pull sections.

For information on structural-mounting requirements and pedestal support, consult your local PG&E project coordinator.

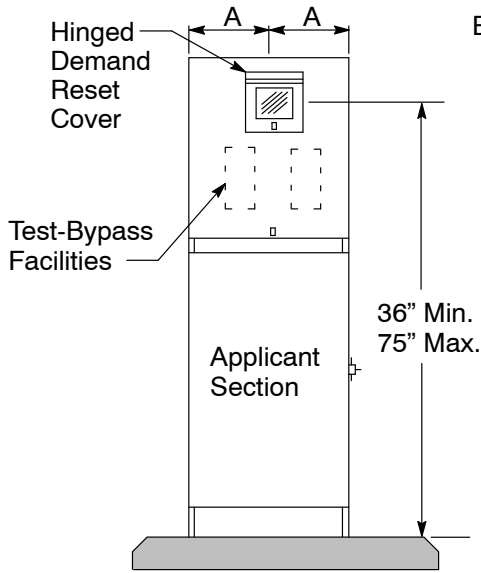

Figure 9-20
Front View

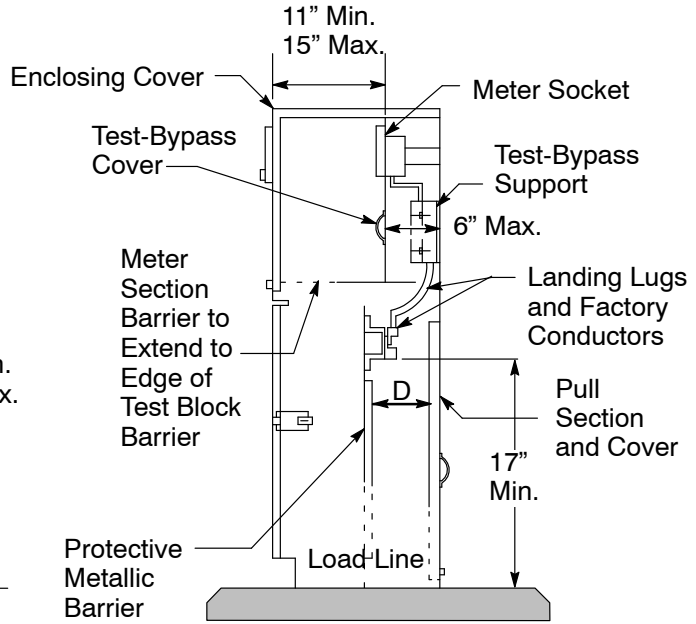

Figure 9-21
Side View

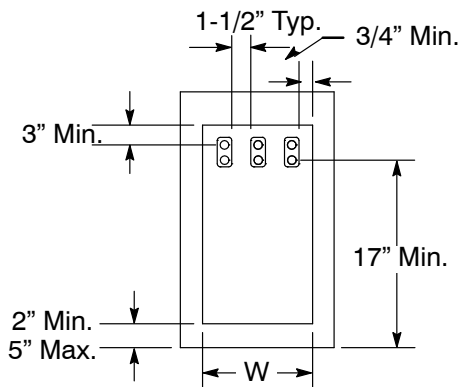

Figure 9-22
Wireway Pull Section

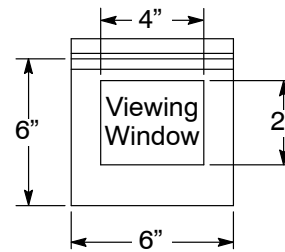

Figure 9-23
Hinged Demand Reset Cover With
Polycarbonate Viewing Window

Table 9-7 Minimum Dimensions (Inches)

Service	W	A	D
Single Phase	10-1/2	10	4.5
Three Phase	12-1/2		

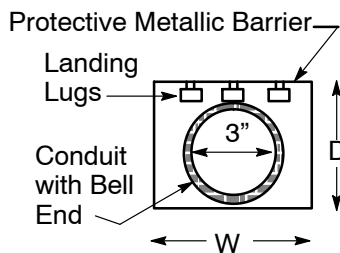

Figure 9-24
Utility Pull Section - Top View

NOTE: These figures represent generic design configurations. To have other designs reviewed and accepted, ask your local project coordinator to consult with the PG&E electric metering department.

This Page Intentionally Left Blank

**SECTION 10
ELECTRIC SWITCHBOARDS:
0 THROUGH 600 VOLTS**

SECTION 10 ELECTRIC SWITCHBOARDS: 0 THROUGH 600 VOLTS

Section 10

Electric Switchboards: 0 Volts Through 600 Volts

10.1. Scope

This section of the manual provides specific dimensions and details for service and meter equipment that is assembled by the manufacturer in freestanding, self-supporting switchboards.

10.2. General Requirements

Applicants must meet the following requirements when they plan to install electric switchboards.

- A. Ensure that switchboard service and meter equipment is built to the requirements of this section.
- B. Ensure that metering switchboard and panelboard drawings, with current ratings of **320 amperes (amps) or above**, are submitted in triplicate to Pacific Gas and Electric Company (PG&E) for review and approval. Drawings must contain specific [Electric Utility Service Requirements Committee \(EUSERC\)](#) or *Electric and Gas Service Requirements (Greenbook)* drawing and sheet numbers for reference purposes. Refer to [Section 5](#), “Electric Metering: General,” Subsection 5.2.2., “Drawing Submittal Requirements for Metering and Service Termination Equipment,” on Page 5-1, for detailed requirements.
- C. Ensure that drawings submitted for PG&E’s review and approval include the following information.
 - The contractor’s name and address
 - The applicant’s name
 - The job location
- D. Before authorizing the manufacture of a switchboard, an applicant must consult his or her local PG&E project coordinator for specific general utility requirements.

NOTE: See [Table FM-1, “Service Planning Office Contact Information.”](#) at the front of this manual starting on Page iv, for specific contact numbers listed by area.

- E. General utility requirements include the following:
 - Horizontal bus-bar requirements
 - Service voltage, phase, and wires
 - Meter-panel requirements to determine the applicable rate schedule
 - Service-termination location
 - Switchboard and/or meter location(s)
 - Size and number of service conductors

- F. PG&E provides and installs meters, metering transformers, test switches, and all secondary wiring from the metering transformers to the meter.
- G. Applicants must ensure that separation exists between the meters and metering transformers for the following reasons.
 - To ensure meter accessibility.
 - To prevent metering inaccuracies.
 - To prevent unacceptable environmental conditions.
- H. Applicants must ensure that rigid steel conduit is installed between the meter and the metering transformers. The rigid steel conduit must be 1-1/4 inches minimum diameter and must be limited to three 90° bends **unless** the applicant provides sealable, accessible, exposed conduits.
- I. Service-entrance conductors must enter the metering transformer compartment from one end and leave from the opposite end. The direction of the feed may be either from the top or from the bottom of the compartment.

Load conductors must **not** reenter or pass through a current transformer (CT) compartment.
- J. When transformer-rated meters are installed for multiple applicants, there must be a separate service section for each installed meter and its associated service switch.
- K. When applicants are installing totalized metering, they are required to install, own, and maintain nominal 1-1/4-inch metal conduit between the switchboard metering facilities.
- L. Applicants should group self-contained meters and switches only when the following conditions are met.
 - 1. Unmetered service entrance conductors and metered load conductors are **not** run in the same conduit raceway or wiring gutter.
 - 2. Each meter position and each service switch or breaker is marked clearly and permanently and is identified by the building owner, or a representative of the building owner, to indicate the occupancy being served.
- M. See Subsection 10.8., “Adding New Metering Equipment to Existing Switchboards,” on Page 10-39, before connecting a new meter panel or meter section to an existing switchboard.

10.3. Switchboard Service Section

A switchboard service section is the section of an applicant’s switchboard provided specifically for terminating the service conductors and for housing the metering transformers (if required), revenue meters, test facilities, and service switch or breaker.

10.3.1. Standard Switchboard Service Section

Applicants must ensure that:

- A. For all switchboard service sections with current ratings of 320 amps or above, the manufacturer submits drawings, in triplicate, to PG&E for approval. See Figure 10-13, “Pull Section,” on Page 10-24, for more information.
- B. Switchboard drawings for **all** co-generation and self-generation installations are submitted to a local PG&E project coordinator for review and approval by the PG&E electric metering department **before** the switchboard is constructed or built. Ask your local project coordinator to submit them.

10.3.2. Specifically Engineered Switchboard Service Sections

A switchboard design that does **not** conform to the [EUSERC](#) standards is considered specially engineered. Typical examples are:

- Switchboards over 3,000 amps.
- Switchboards with service-breaker ratings too large for the standard switchboard service section.
- Multimeter service sections.

The general arrangement of the specially engineered switchboard service sections must follow, as nearly as possible, the requirements for standard switchboard service sections, as described in Subsection 10.3.1., “Standard Switchboard Service Section” (above), and the requirements described in Subsection 10.3.3., “Requirements for All Switchboard Service Sections” (below).

10.3.3. Requirements for All Switchboard Service Sections

This subsection describes the general requirements for all switchboard service sections and applies to all applicants.

- A. The general arrangement and spacing of CTs and the methods of mounting CTs must conform as closely as possible to the illustrations in Figure 10-1 through Figure 10-7 on Page 10-6 through Page 10-15.
- B. Mount the socket meters that are used with metering transformers on hinged panels. Mount the self-contained meters on nonhinged panels.
- C. When a hinged meter panel is located behind an enclosure door, leave a clear space of at least 11 inches between the meter panel and the door. That is the minimum space required to mount the meter.
- D. The meter panels must open at least 90° after the meters and test facilities are in place. If needed, applicants must increase the width of the section to meet these requirements.
- E. Applicants must provide a clear space in the back of a meter panel for the secondary wiring and associated equipment.

- F. For **hinged meter panel doors**, applicants must provide at least the minimum dimensions between the facility's meter panel and the nearest bus, as shown in Figure 10-1 through Figure 10-7 on Page 10-6 through Page 10-15.
- G. For **nonhinged meter panel doors**, applicants must provide a clear space of at least 4 inches to any barrier or obstruction.
- H. Applicants must ensure that the minimum clearance be maintained between meters as shown in Figure 10-12, "Standard Section for Self-Contained Meter Sockets, 0 Amps–225 Amps, Installed in Switchboards: Nonresidential," on Page 10-22, and Figure 10-13, "Pull Section," on Page 10-24.
- I. An applicant must maintain a minimum clear space of 4 inches directly below the bottom slot of the meter test switch. This space permits test leads to be connected safely.
- J. Applicants must **not** mount more than two self-contained meters on any removable meter panel.
- K. Applicants must ensure that panels providing access to metering transformers or a service-terminating pull section are no larger than 9 square feet in area. Removable panels must have two lifting handles.
- L. Applicants must ensure that the front edge of the CT bus bars are located in the same switchboard section, and in the same vertical plane.
- M. Applicants must use either one-bolt or four-bolt connections for switchboards that are rated 1,001 amps through 3,000 amps and have 4-inch buses installed. For switchboards with 5-inch buses, use either two-bolt or six-bolt connections.
- N. Applicants must ensure that buses are securely supported in the metering transformer compartment to withstand the mechanical stresses of a short circuit and to resist movement. The bus supports must **not** interfere when CTs either are installed or are removed. Do **not** use CTs to support the buses.
- O. Applicants should ensure that the buses and CT mountings are designed so that each of the CTs can be removed from its mounting position directly through the access panel without disturbing any other CT. When using multi-leaf buses, orient the buses so that they appear "edgewise" when viewed from the access panel.
- P. When using an aluminum bus, applicants must ensure that the aluminum bus bar is **plated** to prevent corrosion.
- Q. Applicants must ensure that all electric meter panels and all equipment doors or panels that are intended to provide access to potential transformers (PTs) and CTs are permanently marked or labeled to indicate the service voltage being supplied.
- R. **In switchboards rated over 800 amps, applicants must ensure that the bus bars extend from the termination section and service landing lugs into the CT compartment.** In switchboards with multiple meters, the bus bars must extend from the termination section and service landing lugs to the meter sockets in multimeter boards.

- S. Switchboard manufacturers must provide accessories, such as additional Belleville washers, at the time of delivery and/or installation.
- T. Switchboards must meet all of the design and test conditions of [Underwriters Laboratories](#) (UL) UL891, “Standard for Switchboards.”
- U. Applicants must ensure that bus arrangement and supports are provided. An **exception** is the neutral bus, which may be located on either sidewall.
- V. Applicants must locate the CT compartment on the supply side of the service-section main switch or breaker.
- W. Applicants must ensure that only metering conductors pass through this CT compartment.
- X. Applicants must ensure that a neutral, bus-bar extension is provided in the instrument transformer compartment **above** the lower CT bus support when the service-section phase buses are supplied from the horizontal cross busing.
- Y. Applicants must ensure that the return flanges for the lower- and upper-meter panel supports do **not** project more than 3/4 inch up or down from the adjacent switchboard panels.
- Z. Applicants must ensure that each bus has a connector that accepts a stranded conductor with the amp capacity of the service-section main switch or breaker.
- AA. Applicants must ensure that the power-leg bus for a 4-wire delta service is identified.
- AB. Applicants must ensure that a removable link is installed in the right-side phase bus when using the service section for three-phase, 3-wire service.
- AC. Applicants must ensure that each switchboard service section is completely barriered from other service sections, pull sections, service switches, or disconnects. Barriers may have an opening to allow unmetered conductors to pass between sections. The barrier between sealed utility metering sections and the pull section must be 1/8 inch minimum, either glastic or equivalent. The clearance between the bus bar and glastic must be a maximum of 3 inches. No barrier is required between individual phases and the neutral.

10.3.4. Standard Switchboard CT Compartment, 0 Amps Through 1,200 Amps, Single-Phase or Three-Phase, 3-Wire Service

Applicants must ensure that the following requirements are met. These requirements apply specifically to this type of CT compartment.

- A. The bus dimensions are a minimum of 1/4 inch by 2 inches and a maximum of 3/4 inch by 2 inches.
- B. The barrier must be constructed of insulating, nontracking material. Ensure that openings in the barrier and clearances to the outer edges do not exceed 3/8 inch. Use non-conductive fasteners to attach the barrier.
- C. The minimum clearance between the meter panel or socket and the bus is 6.5 inches up to 1,000 amps, and 7.5 inches for 1,200-amp compartments. If a clearance of 7.5 inches is not possible, use a 4-inch bus as required in Subsection 10.3.6., “Standard Switchboard CT Compartment, 1,001 Amps Through 3,000 Amps, Single-Phase or Three-Phase, 3-Wire Service,” on Page 10-8.

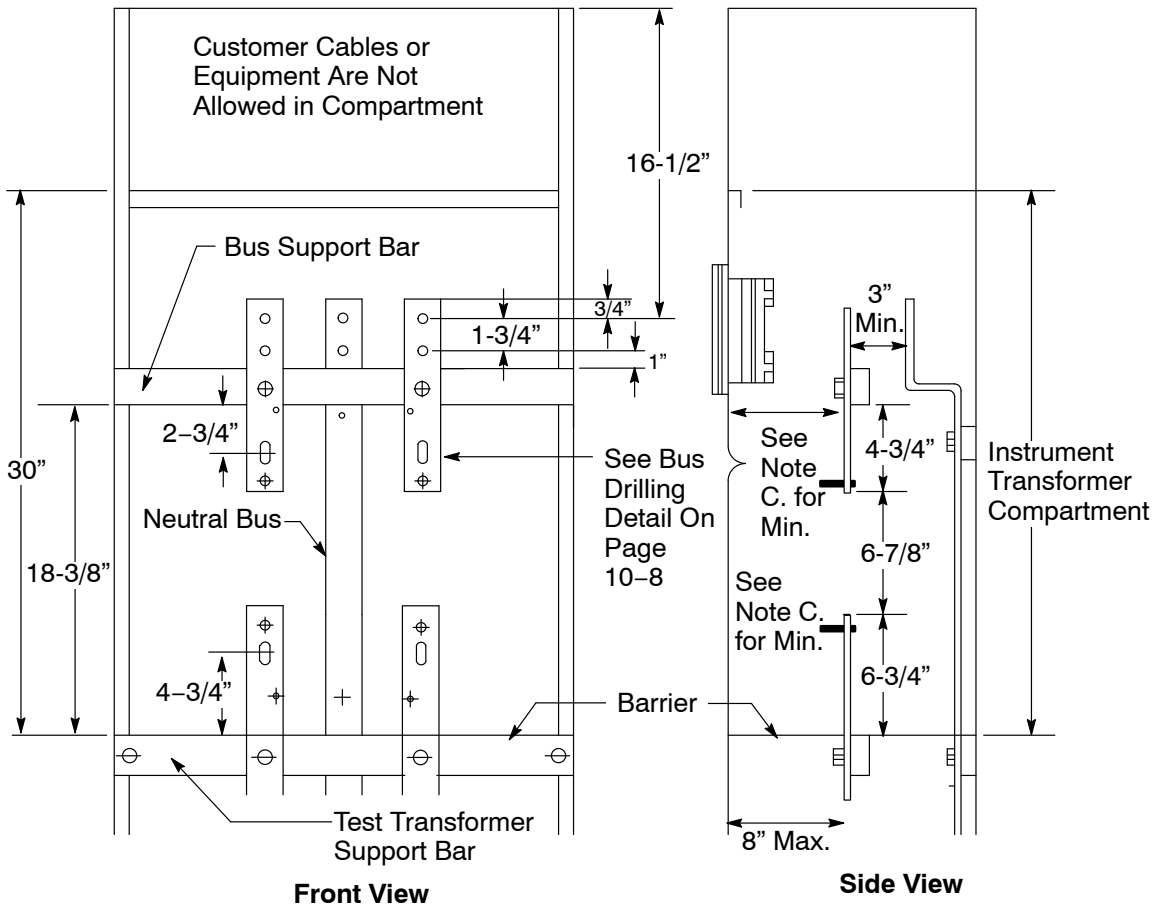

Figure 10-1
Standard Switchboard, CT Compartment, 0 Amps–1,200 Amps,
Single-Phase or Three-Phase, 3-Wire Service

10.3.5. Standard Switchboard CT Compartment, 0 Amps Through 1,200 Amps, Three-Phase, 3-Wire and 4-Wire Services

Applicants must ensure that the following requirements are met. These requirements apply specifically to this type of CT compartment.

- A. Ensure that the bus dimensions are a minimum of 1/4 inch by 2 inches and a maximum of 3/4 inch by 2 inches.
- B. Ensure that the barrier is made of an insulating, nontracking material. Ensure that openings in the barrier and clearances to the outer edges do not exceed 3/8 inch. Use non-conductive fasteners to attach the barrier.
- C. The minimum clearance between the meter panel or socket and the bus is 6.5 inches up to 1,000 amps and 7.5 inches for 1,200 amp compartments. If a clearance of 7.5 inches is not possible, use a 4-inch bus as required in Subsection 10.3.7. on Page 10-10.

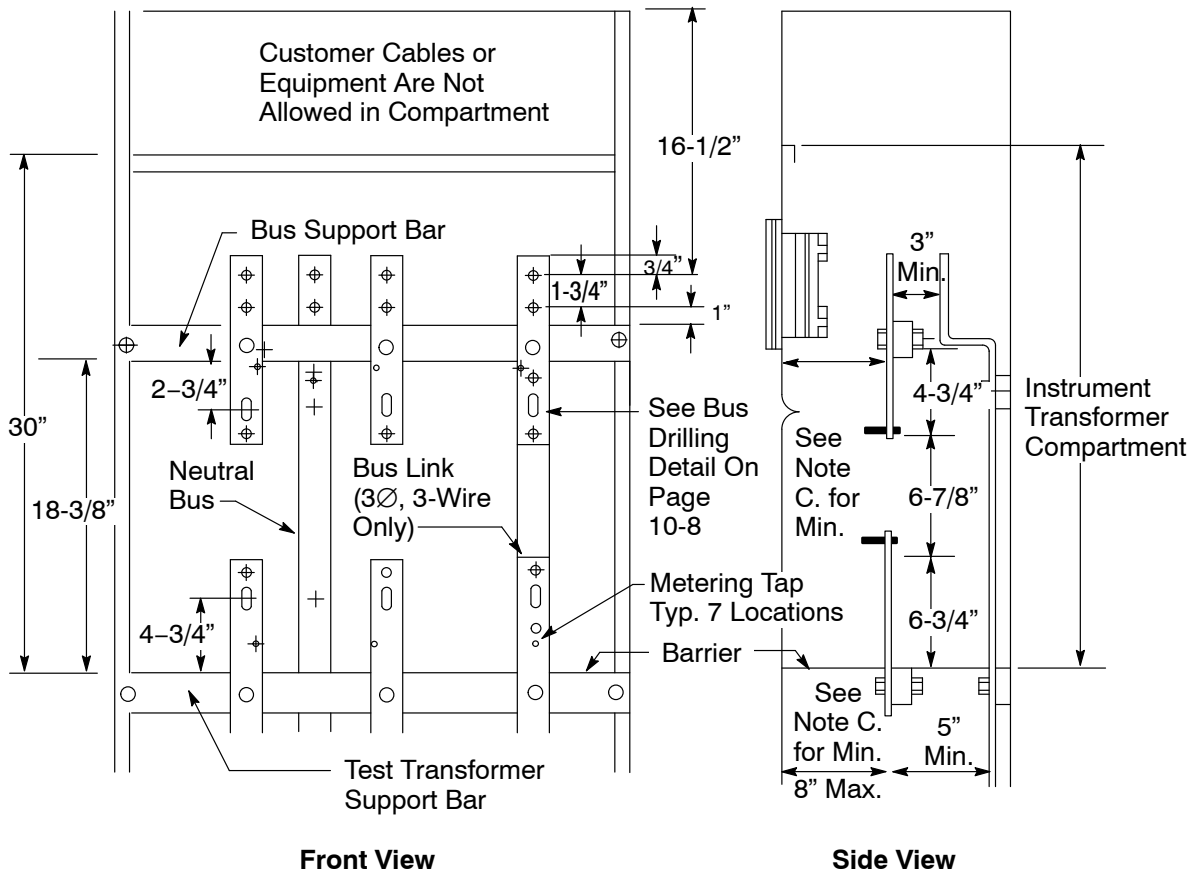
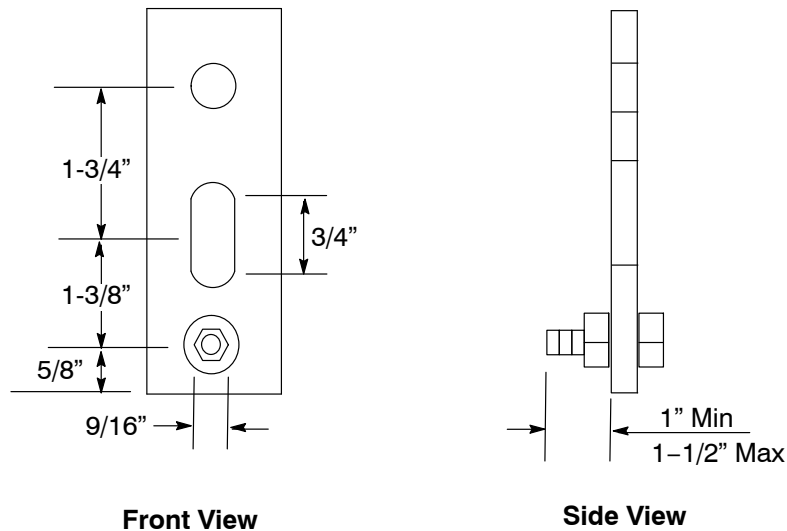

Figure 10-2
Standard Switchboard, CT Compartment, 0 Amps–1,200 Amps,
Three-Phase, 3-Wire and 4-Wire Services



**Figure 10-3
Bus Drilling Detail**

10.3.6. Standard Switchboard CT Compartment, 1,001 Amps Through 3,000 Amps, Single-Phase or Three-Phase, 3-Wire Service

The following requirements specifically apply to the CT compartment shown in Figure 10-4, “Standard Switchboard, CT Compartment, 1,001 Amps–3,000 Amps, Single-Phase or Three-Phase, 3-Wire Service,” on Page 10-9. Applicants must:

- A. Ensure that the buses are anchored so that they will remain in position when the removable section is out.
- B. Ensure that the bus corners are rounded to prevent damaging the insulation.
- C. For underground services, ensure that the buses extend into the pull section.
- D. Be aware that the maximum permissible bus unit consists of four 1/4-inch by 4-inch bars spaced 1/4 inch apart.
- E. Ensure that the barrier is a minimum of 45 inches and a maximum of 50 inches above the standing surface.
- F. For a single-phase switchboard, ensure that the neutral bus is located at the side of the compartment.
- G. Ensure that the switchboard manufacturer secures the removable bus link to the upper- and lower-CT bus units using 1/2-inch hex-head (Grade 5) steel bolts with 2-1/4-inch diameter Belleville washer and nut.
- H. Ensure that openings in the barrier and clearances to the outer edges do not exceed 3/8 inch. Use nonconductive fasteners to attach the barrier.

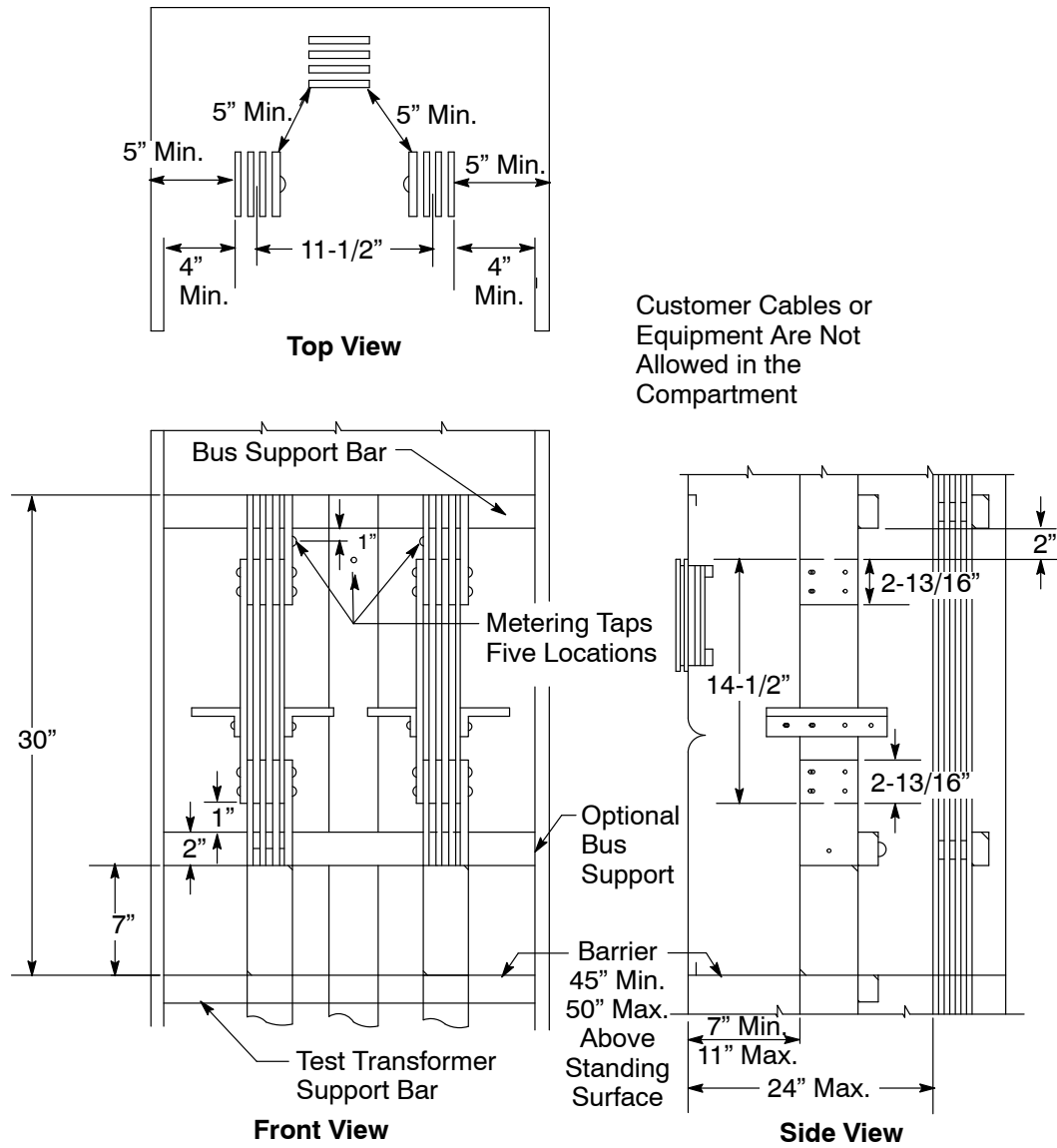

Figure 10-4
Standard Switchboard, CT Compartment, 1,001 Amps–3,000 Amps,
Single-Phase or Three-Phase, 3-Wire Service

10.3.7. Standard Switchboard, CT Compartment, 1,001 Amps Through 3,000 Amps, Three-Phase, 4-Wire Service

The following requirements specifically apply to the CT compartment shown in Figure 10-5, “Standard Switchboard, CT Compartment, 1,001 Amps–3,000 Amps, Three-Phase, 4-Wire Service,” on Page 10-11. Applicants must:

- A. Ensure that the buses are anchored so that they will remain in position when the removable section is out.
- B. Ensure that the bus corners are rounded to prevent damaging the insulation.
- C. For underground services, ensure that the buses extend into the pull section.
- D. Be aware that the maximum permissible bus unit consists of four 1/4-inch by 4-inch bars spaced 1/4 inch apart.
- E. Ensure that the barrier is a minimum of 45 inches and a maximum of 50 inches above the standing surface.
- F. Ensure that the switchboard manufacturer secures the removable bus link to the upper- and lower-CT bus units using 1/2-inch hex-head (Grade 5) steel bolts with 2-1/4-inch diameter Belleville washers and nuts.
- G. Ensure that openings in the barrier and clearances to the outer edges do not exceed 3/8 inch. Use nonconductive fasteners to attach the barrier.

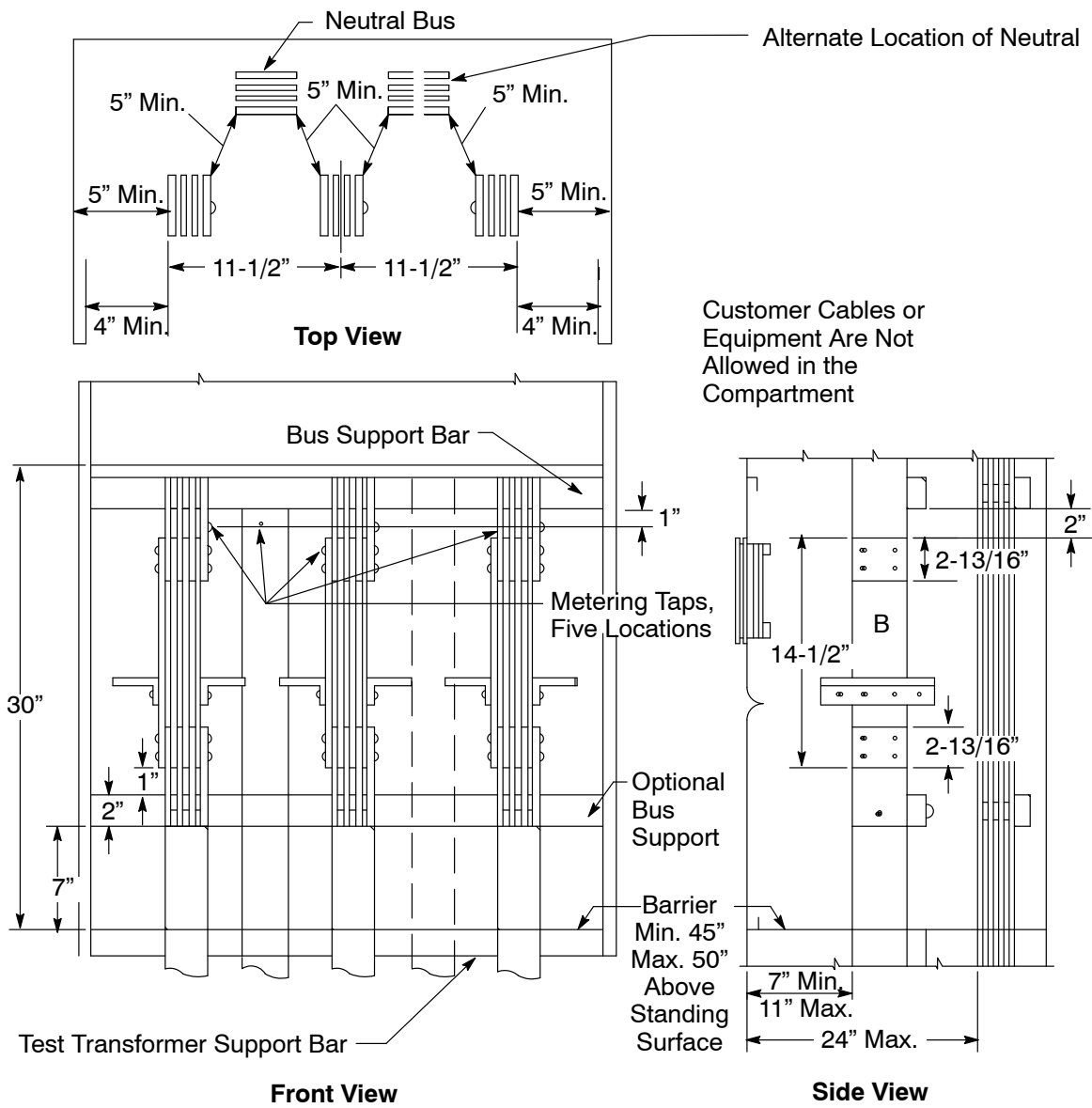

Figure 10-5
Standard Switchboard, CT Compartment, 1,001 Amps–3,000 Amps,
Three-Phase, 4-Wire Service

10.3.8. Standard Switchboard CT Compartment, 3,001 Amps and Larger, Three-Phase, 3-Wire Service

The following requirements specifically apply to the CT compartment shown in Figure 10-6, “Standard Switchboard, CT Compartment, 3,001 Amps and Larger, Three-Phase, 3-Wire Service,” on Page 10-13.

Applicants must:

- A. Ensure that the buses are anchored so that they will remain in position when the removable section is out.
- B. Ensure that the bus corners are rounded to prevent damaging the insulation.
- C. For underground services, ensure that the buses extend into the pull section.
- D. Be aware that the maximum permissible bus unit consists of four 1/4-inch by 4-inch bars spaced 1/4 inch apart.
- E. Ensure that the barrier is a minimum of 45 inches and a maximum of 50 inches above the standing surface.
- F. Ensure that the switchboard manufacturer secures the removable bus link to the upper- and lower-CT bus units using 1/2-inch, hex-head (Grade 5) steel bolts with 2-1/4-inch diameter Belleville washers and nuts.
- G. Ensure that openings in the barrier and clearances to the outer edges do not exceed 3/8 inch. Use nonconductive fasteners to attach the barrier.

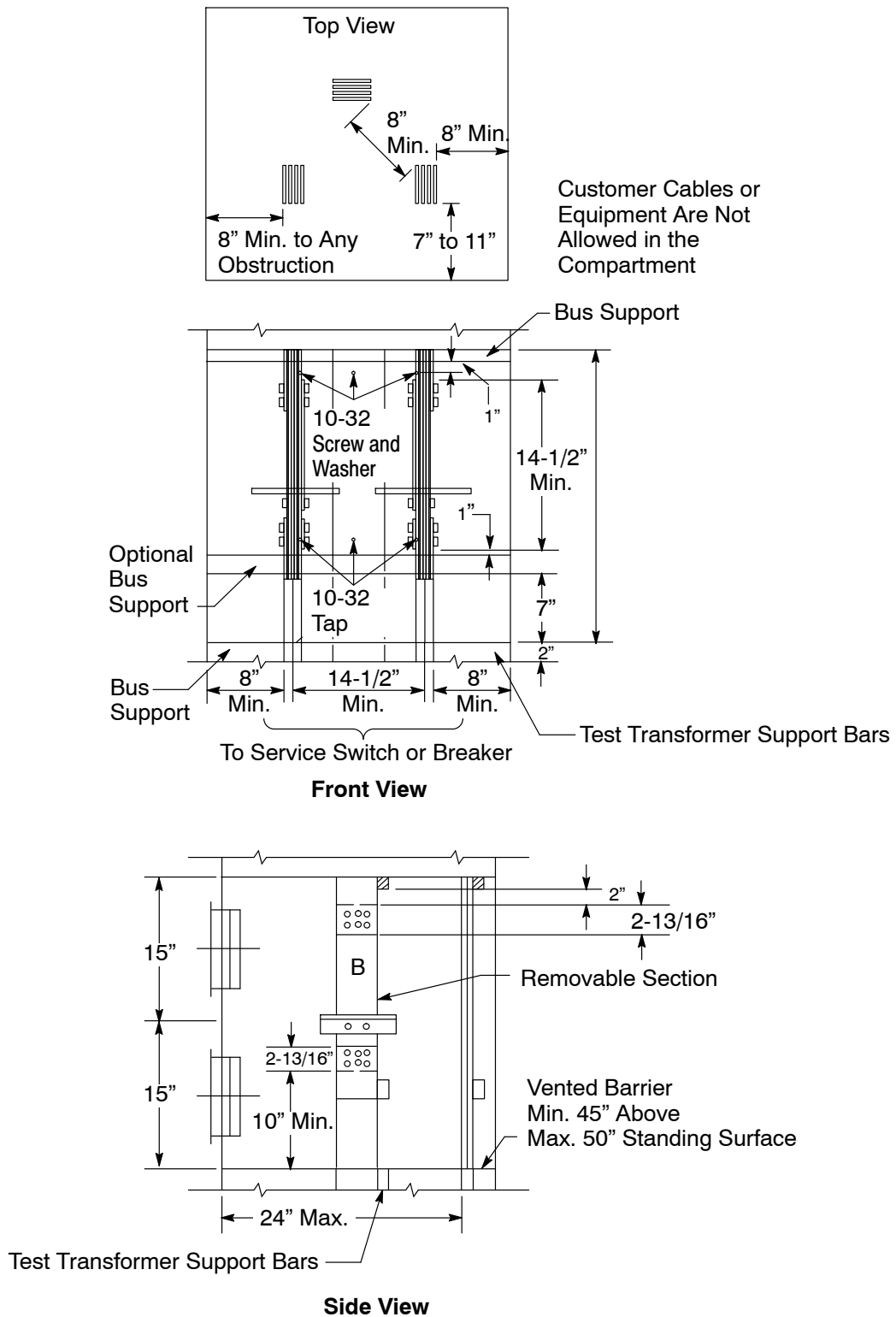

Figure 10-6
Standard Switchboard, CT Compartment, 3,001 Amps and Larger,
Three-Phase, 3-Wire Service

10.3.9. Standard Switchboard CT Compartment, 3,001 Amps and Larger, Three-Phase, 3-Wire or 4-Wire Service

The following requirements specifically apply to the CT compartments shown in Figure 10-7, “Standard Switchboard, CT Compartment, 3,001 Amps and Larger, Three-Phase, 3-Wire or 4-Wire Service,” on Page 10-15. Applicants must:

- A. Ensure that the buses are anchored so that they will remain in position when the removable section is out.
- B. Ensure that the bus corners are rounded to prevent damaging the insulation.
- C. For underground services, ensure that the buses extend into the pull section.
- D. Be aware that the maximum permissible bus unit consists of four 1/4-inch by 4-inch bars spaced 1/4 inch apart.
- E. Ensure that the barrier is a minimum of 45 inches and a maximum of 50 inches above the standing surface.
- F. Ensure that the switchboard manufacturer secures the removable bus link to the upper- and lower-CT bus units using 1/2-inch hex-head (Grade 5) steel bolts with 2-1/4-inch diameter Belleville washers and nuts.

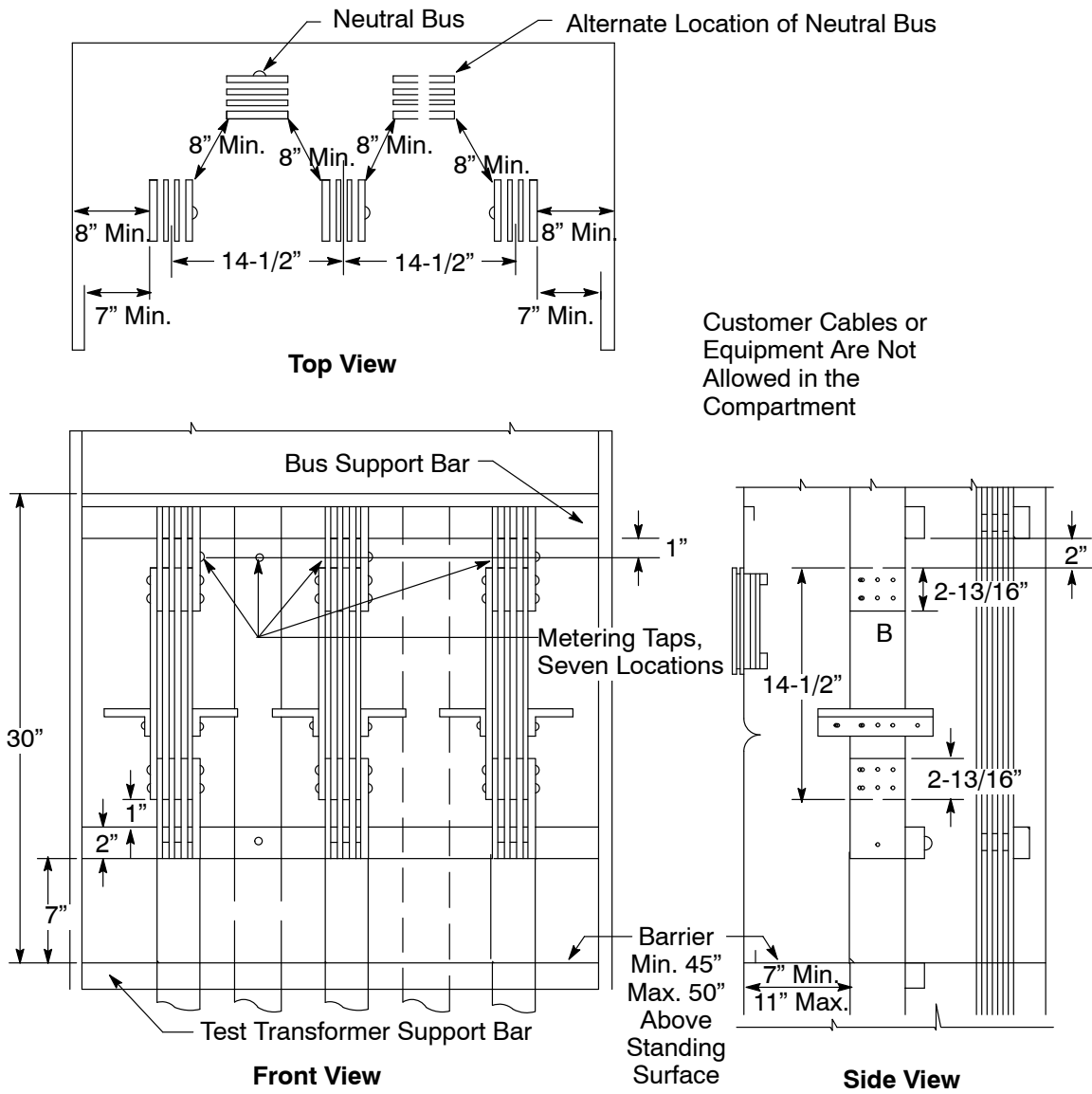

Figure 10-7
Standard Switchboard, CT Compartment, 3,001 Amps and Larger,
Three-Phase, 3-Wire or 4-Wire Service

10.3.10. Removable Link Assemblies

The removable link assemblies for 0-volt through 600-volt CT compartments from 1,001 amps through 3,000 amps, and 3,001 amps and larger, are shown in Figure 10-8 through Figure 10-11 on Page 10-17 through Page 10-20.

Applicants may use either a one-bolt connection, as shown in Figure 10-8, “Switchboards, 0 Volts–600 Volts, CT Compartment, 1,001 Amps–3,000 Amps, Removable Link and CT Support (One-Bolt Configuration),” on Page 10-17, or a four-bolt connection, as shown in Figure 10-9, “Switchboards, 0 Volts–600 Volts, CT Compartment, 1,001 Amps–3,000 Amps, Removable Link and CT Support (Four-Bolt Configuration),” on Page 10-18, for switchboards that are rated 1,001 amps to 3,000 amps and have 4-inch buses installed.

For switchboards with 5-inch buses, use either two bolts, as shown in Figure 10-10, “Switchboards, 0 Volts–600 Volts, CT Compartment, 3,001 Amps and Larger, Removable Link and CT Support (Two-Bolt Configuration),” on Page 10-19, or six bolts, as shown in Figure 10-11, “Switchboards, 0 Volts–600 Volts, CT Compartment, 3,001 Amps and Larger, Removable Link and CT Support (Six-Bolt Configuration),” on Page 10-20.

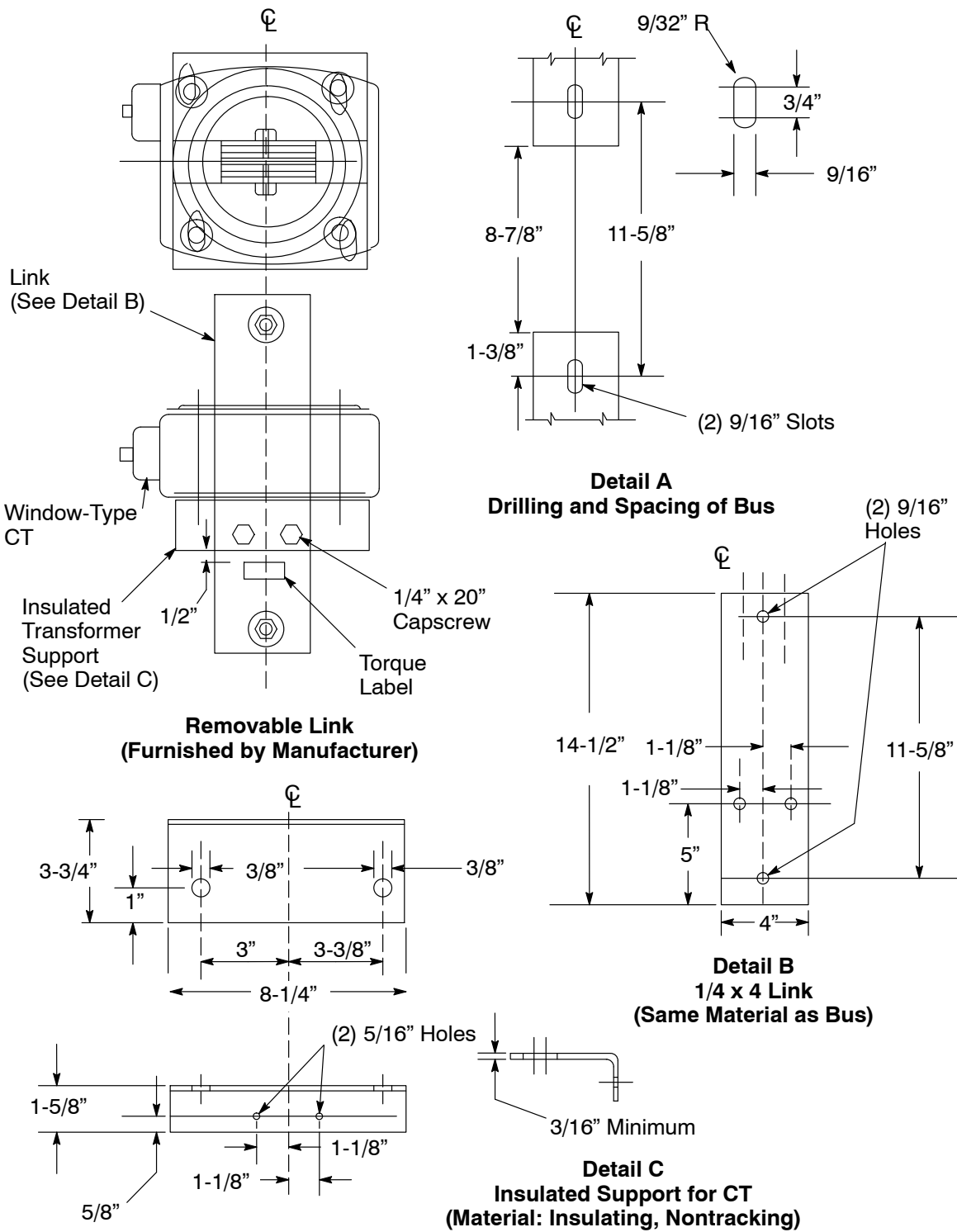

Figure 10-8
Switchboards, 0 Volts–600 Volts, CT Compartment, 1,001 Amps–3,000 Amps,
Removable Link and CT Support (One-Bolt Configuration)

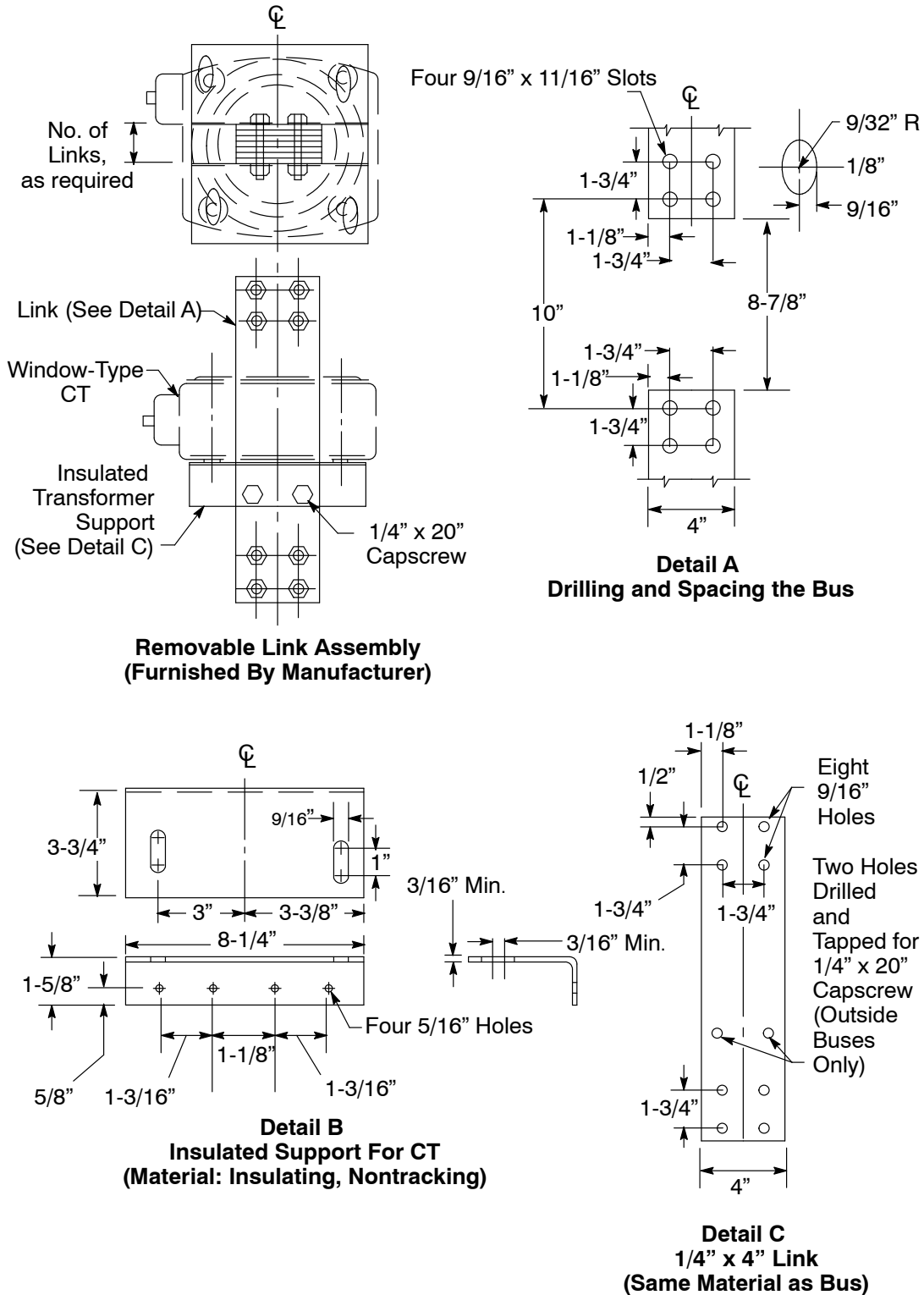

Figure 10-9
Switchboards, 0 Volts–600 Volts, CT Compartment, 1,001 Amps–3,000 Amps, Removable Link and CT Support (Four-Bolt Configuration)

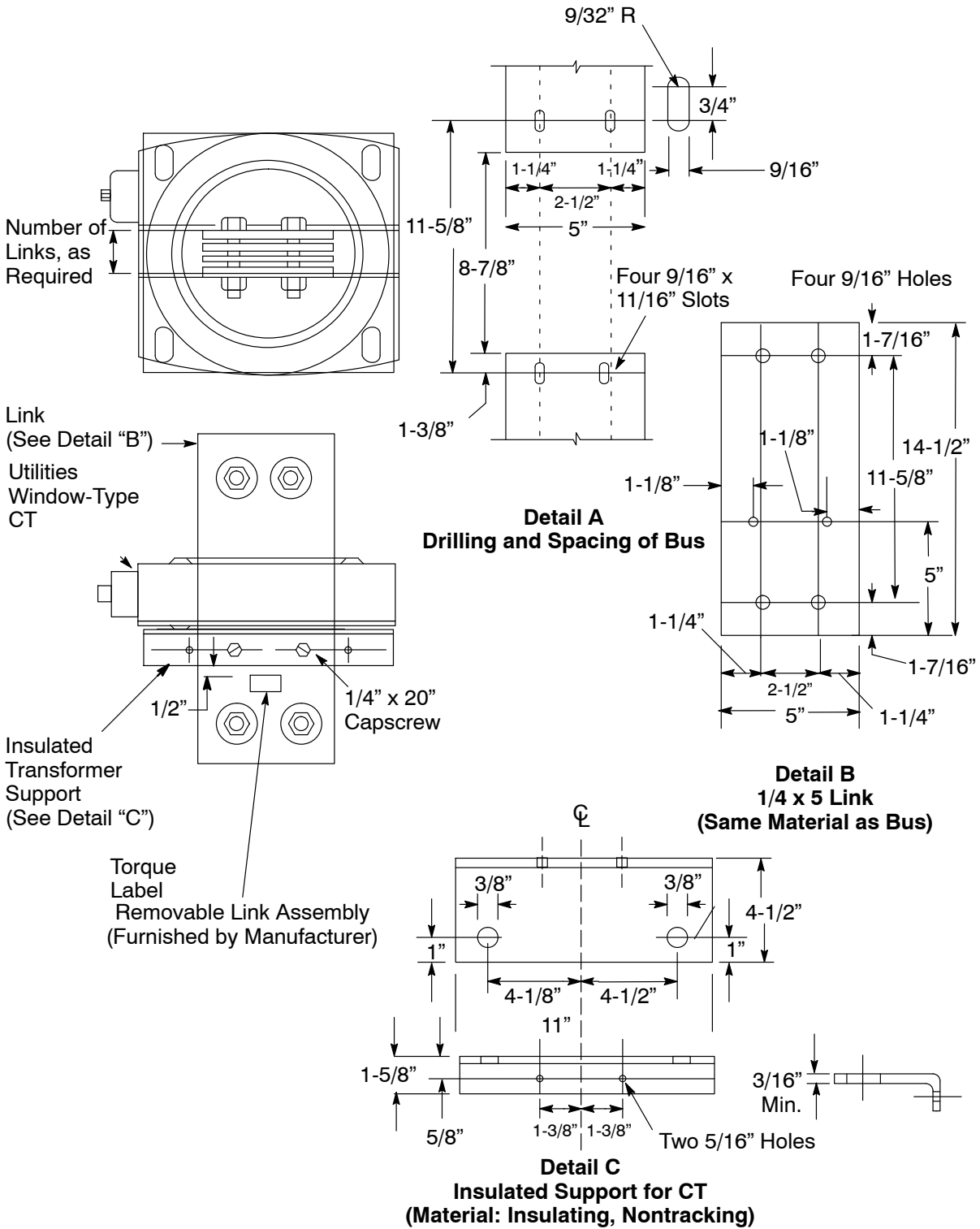

Figure 10-10
Switchboards, 0 Volts–600 Volts, CT Compartment, 3,001 Amps and Larger,
Removable Link and CT Support (Two-Bolt Configuration)

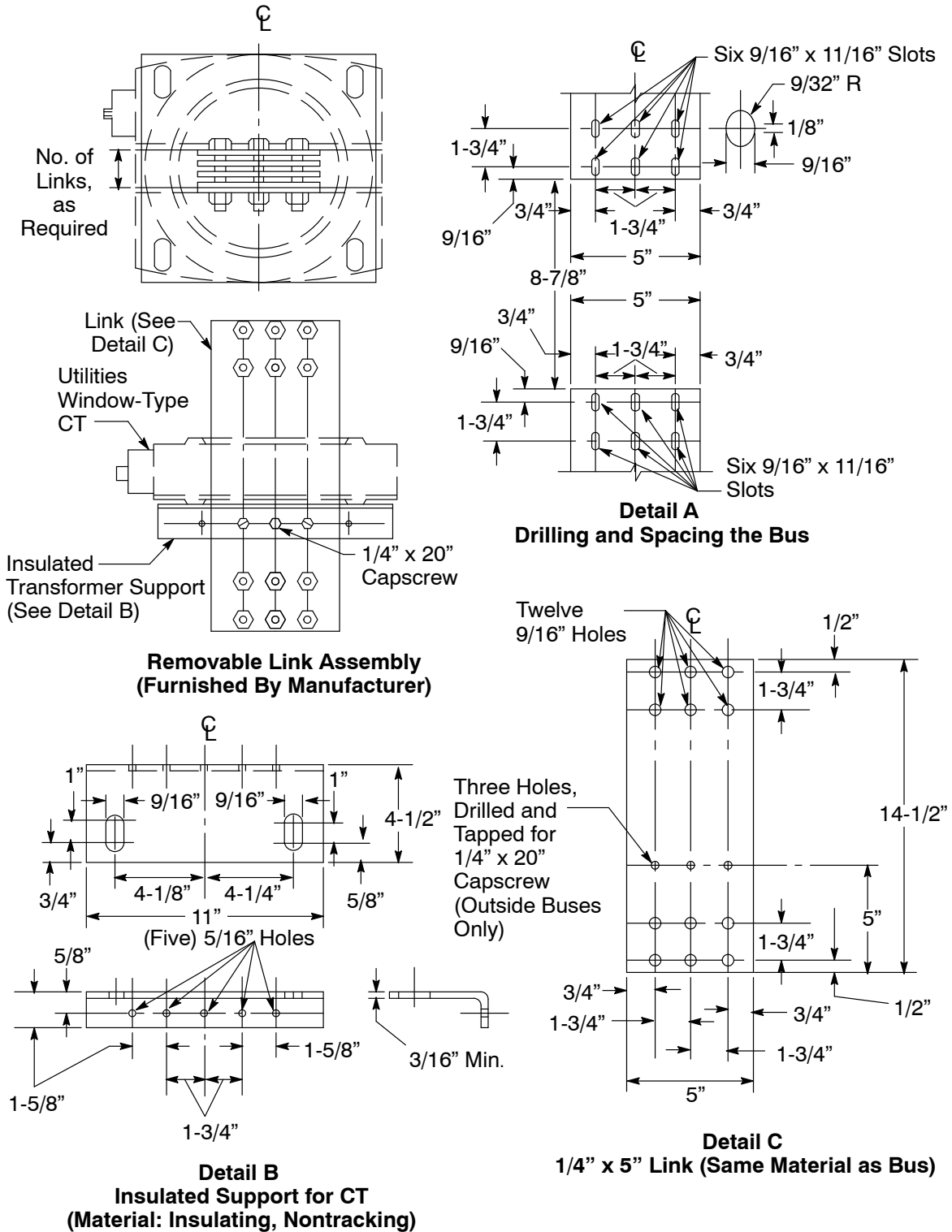

Figure 10-11
Switchboards, 0 Volts–600 Volts, CT Compartment,
3,001 Amps and Larger, Removable Link and CT Support (Six-Bolt Configuration)

10.3.11. Standard Section for Self-Contained Meter Sockets, 0 Amps Through 225 Amps, Installed in Switchboards: Nonresidential

These requirements apply specifically to switchboard service sections for nonresidential, 0-amp through 225-amp meter sockets. Applicants must:

- A. Ensure that the manufacturer furnishes, installs, and wires or buses the test-bypass blocks to the meter socket with four, rigid, insulating barriers. Test blocks must conform to the requirements described in [Section 9](#), “Electric Metering: Components.”
- B. Ensure that the metered conductors do **not** pass through the adjacent metering compartments, except in enclosed wireways.
- C. Ensure that the meter panels are removable with a maximum of two meters per panel.
- D. Ensure that the cover panels for the test-bypass block are sealable and fitted with handles. Panels more than 16 inches wide must have two handles.
- E. Ensure that outdoor or rain-tight enclosures are used, as shown in Figure 10-29 through Figure 10-32, “Outdoor or Rain-Tight Enclosures for Switchboards,” on Page 10-38.
- F. When a neutral is required for metering or testing, ensure that an insulated neutral terminal is provided behind each test-bypass cover panel. The terminal must be readily accessible when the cover panel is removed and must be individually connected to the neutral bus with a minimum Size #8 American wire gauge (AWG) copper wire.
- G. Ensure that factory-installed, full-width, insulating barriers are located at the bottom of each test-bypass compartment. The insulating barrier must deflect a 1/2-inch maximum from a 25-pound downward force.
- H. For three-phase, 4-wire service, ensure that the seventh jaw is connected to the body of the neutral lug with an AWG #12 copper wire.
 - I. For three-phase, 4-wire, delta-connected service, ensure that the right-hand, test-bypass block (i.e., two poles) is identified as a power leg.
- J. For three-phase, 3-wire service, ensure that the bus is installed to connect the line and load poles together at the top of the center test-bypass block and the fifth jaw is connected to this bus using an AWG #12 copper wire.
- K. For single-phase, 3-wire service, ensure that the center test-bypass block is omitted.
- L. For single-phase, 3-wire, 120/208-volt service, ensure that the center test-bypass block is omitted and the fifth jaw is connected to the body of the neutral lug with an AWG #12 copper wire.
- M. Ensure that the meter panels are removable. However, they must **not** be removable when the meter is in place. Ensure that the meter socket is attached to the meter panel, and yet is supported independently from the meter panel.

- N. Ensure that each line and load position is identified clearly by using 3/4-inch (minimum) block-letter labeling.
- O. Ensure that all of the meter panels are sealable and all of the securing screws are captive.

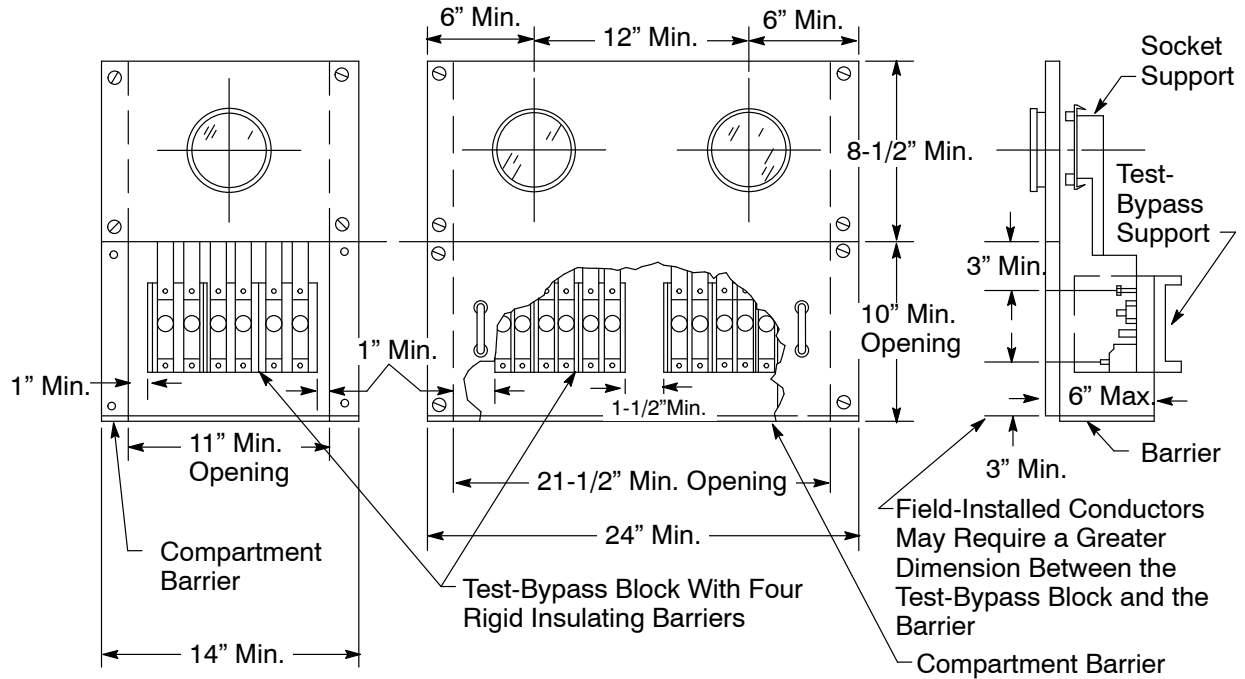

Figure 10-12
Standard Section for Self-Contained Meter Sockets, 0 Amps–225 Amps,
Installed in Switchboards: Nonresidential

10.3.12. Service Terminations for Underground Services

NOTE: For overhead services where conductors go into the bottom-fed termination section, the applicant must connect the service-entrance conductors to the line side of the bus stubs in the metering-transformer compartment.

PG&E pulls and terminates its service conductors when terminating facilities that are provided by the applicant as shown in Figure 10-13, “Pull Section,” Figure 10-14, “Separate Pull Box,” and Figure 10-15, “Bottom-Fed Service Section,” all on Page 10-24. The requirements for pulling and terminating service are provided in the following paragraphs.

Applicants must:

- A. When the service section is served from a pull section, ensure that the bus or cable conductors enter in one of the following two ways:
 1. Enter through the side or back in the sealable section above the CT compartment, as shown in Figure 10-13 on Page 10-24.
 2. Enter by means of horizontal cross-busing in back of the metering compartment.
- B. Ensure that all pull and terminating sections provide full-front access.
- C. Ensure that all of the cover panels for the pull section have all of the following attributes:
 - Are removable and sealable.
 - Have two lifting handles.
 - Are limited to a maximum size of 9 square feet in area.
- D. Ensure that the power leg for a 4-wire delta service is identified effectively at the point of termination **before** making the service connection.
- E. Ensure that the minimum width of the pull section has the dimensions specified in Table 10-1, “Minimum Bottom-Fed Pull-Section Dimensions,” on Page 10-24.

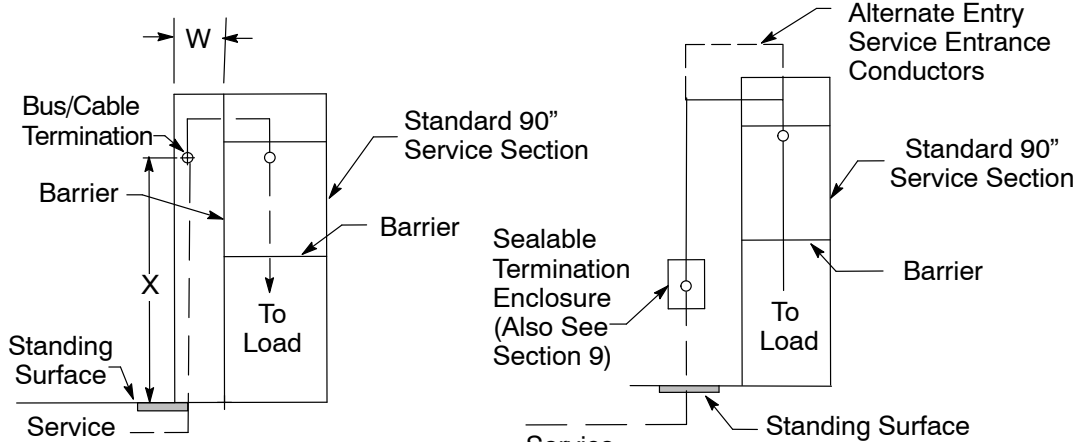

**Figure 10-13
Pull Section**

**Figure 10-14
Separate Pull Box**

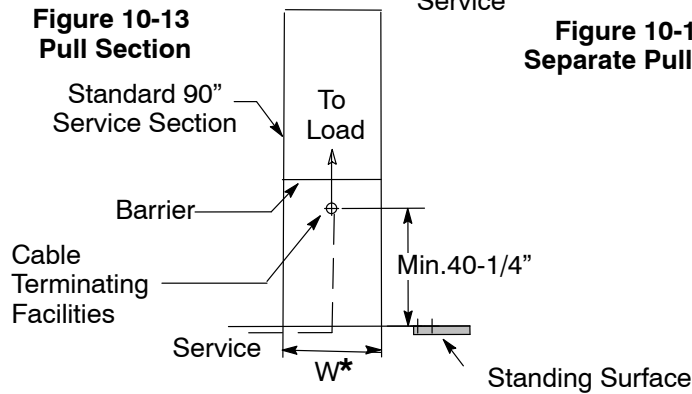

**Figure 10-15
Bottom-Fed Service Section**

* The minimum width of the pull section must meet the requirements specified in Table 10-1, below.

Table 10-1 Minimum Bottom-Fed Pull-Section Dimensions

Switchboard Rating (Amps)	Minimum Access Opening Dimension (W) ²		Termination Height X
	3-Wire	4-Wire	
Below 400	Consult Serving Agency (All Measurements in Inches)		
400–800	24	24	42 Min. ¹ –72 Max.
801–1,200	24	30	
1,201–2,000	30	35	
2,001–2,500	—	42	60 Min.–72 Max.
2,501–4,000	Bus Duct		

¹ See Figure 10-15, “Bottom-Fed Service Section,” on Page 10-24, for the minimum termination height of a bottom-fed service section.

² If the landing stubs in the termination bus are installed perpendicular to the back of the board, PG&E requires the enclosure dimensions to be wider to accommodate the cable installation.

10.3.13. Underground, Service-Termination Pull Section (Located Below Ground Level)

Applicants must follow the requirements in this subsection when underground, service-termination pull sections are located below the ground level.

NOTE: To prevent the accumulation of water in meter rooms, refer to Subsection 3.3.7., “Providing Drainage From the Conduit System,” on Page 3-10.

- A. **Back Entry:** When a service must enter the back of a switchboard pull section, as shown in Figure 10-16, “Switchboard Pull Section, High Entry,” located on Page 10-26, the pull space must have the required X dimension above or below the cable-terminating facilities. The pull sections must also have the required W dimension, as shown in Table 10-2, “Pull Section Dimensions (Minimums) Below Ground Level,” located on Page 10-27.
- B. **Side Entry:** When a service must enter the side of a switchboard pull section, as shown in Figure 10-16 on Page 10-26, and in Figure 10-17, “Switchboard Pull Section, Low Entry,” on Page 10-26, the pull-space must have the required X dimension above or below the cable-terminating facilities. The pull sections must also have the required W dimension, as shown in Table 10-2.
- C. **Additional or Extended Section Entry:** When it is not possible to meet the requirements of dimension X because the service cannot enter the upper or lower areas of the switchboard pull section, or because additional space is needed, another enclosure can be attached to the termination section enclosure. Figure 10-18, “Extended Top on Switchboard Pull Section,” on Page 10-27, Figure 10-19, “Additional Side or Back Switchboard Pull Section-High Entry,” on Page 10-28, Figure 10-21, “Additional Side or Back Switchboard Pull Section, Low Entry,” on Page 10-32 show examples of how another enclosure provides additional space for the cables to enter the termination section either low or high enough to meet the X dimension and facilitate proper cable termination. PG&E recommends that applicants submit drawings for review before installing an additional enclosure and applicants to attend a pre-inspection meeting.
- D. **Conduit:** Service conduit installed in the franchise area (i.e., public property) must not be at a depth greater than 60 inches. Conduit entering the switchboard must be group together in a maximum of two rows and centered horizontally in the pull-section wall.
- E. **X Dimension:** The X dimension is the measured distance from the horizontal center position of the termination bus to the closest service conduit installed in the pull section for Figure 10-16 on Page 10-26 through Figure 10-18 on Page 10-27. When an additional pull section is used, as shown in Figure 10-19 on Page 10-28 and Figure 10-20 on Page 10-29, the X dimension is measured from the horizontal center position of the termination bus to the closest position where the service cable will enter into the termination section.

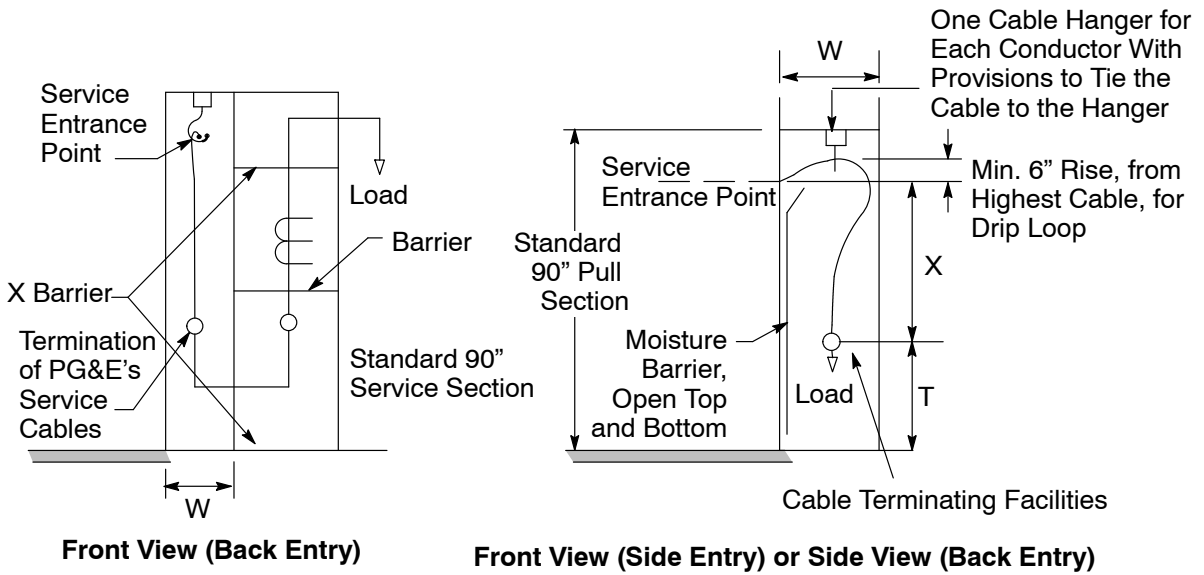

Figure 10-16
Switchboard Pull Section, High Entry

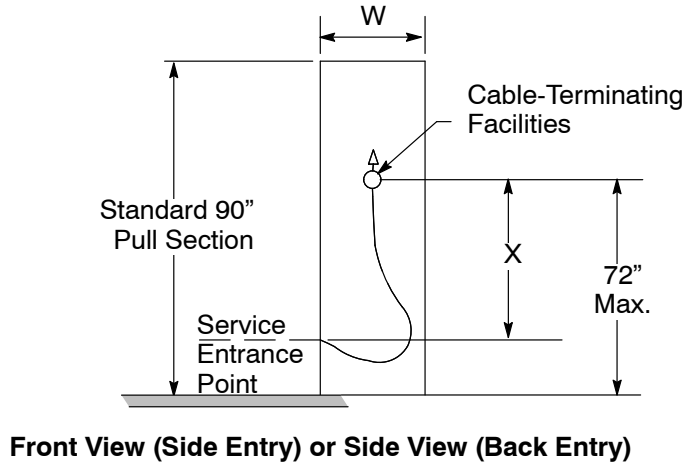

Figure 10-17
Switchboard Pull Section, Low Entry

Table 10-2 Pull-Section Dimensions (Minimums) Below Ground Level

Switchboard Rating in Amps	W ^{1, 2}		X ³	T
	1∅ 3-Wire	3∅ 4-Wire	Side or Back Entry	Termination Height
	Measurements in Inches			
201–800	24	24	42	24
801–1,200	24	30	42	24
1,201–2,000	30	35	45	24
2,001–2,500	—	42	60	18
2,501–4,000	Bus Duct			

- ¹ Ensure that the dimension (i.e., width, depth, and height) of the additional pull section are exactly the same as the terminating section.
- ² If the landing stubs in the termination bus are installed perpendicular to the back of the board, PG&E requires the enclosure dimensions to be wider to accommodate cable installation.
- ³ See Item E., "X Dimension," on Page 10-25.

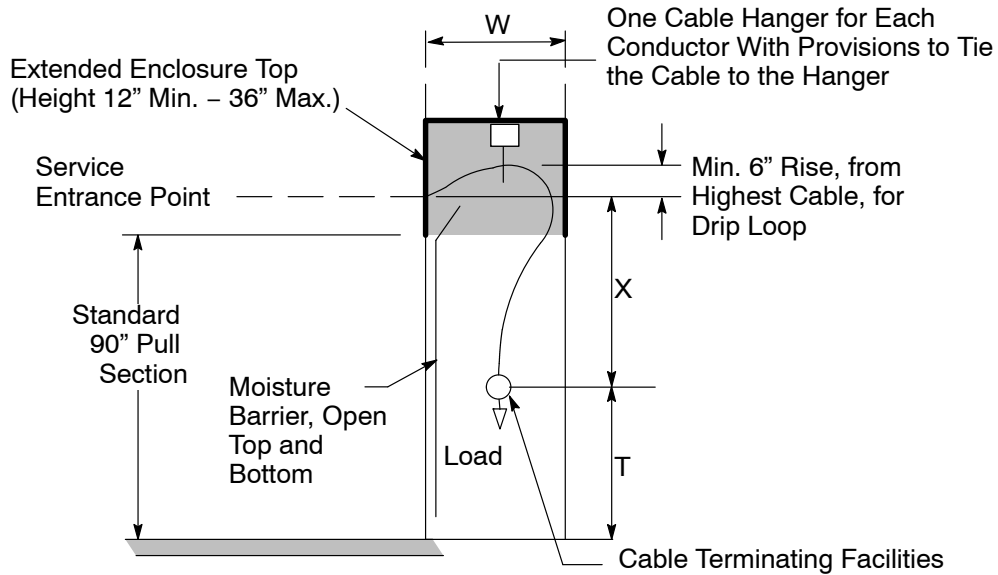

Figure 10-18
Extended Top on Switchboard Pull Section
Front View (Side Entry) or Side View (Back Entry)

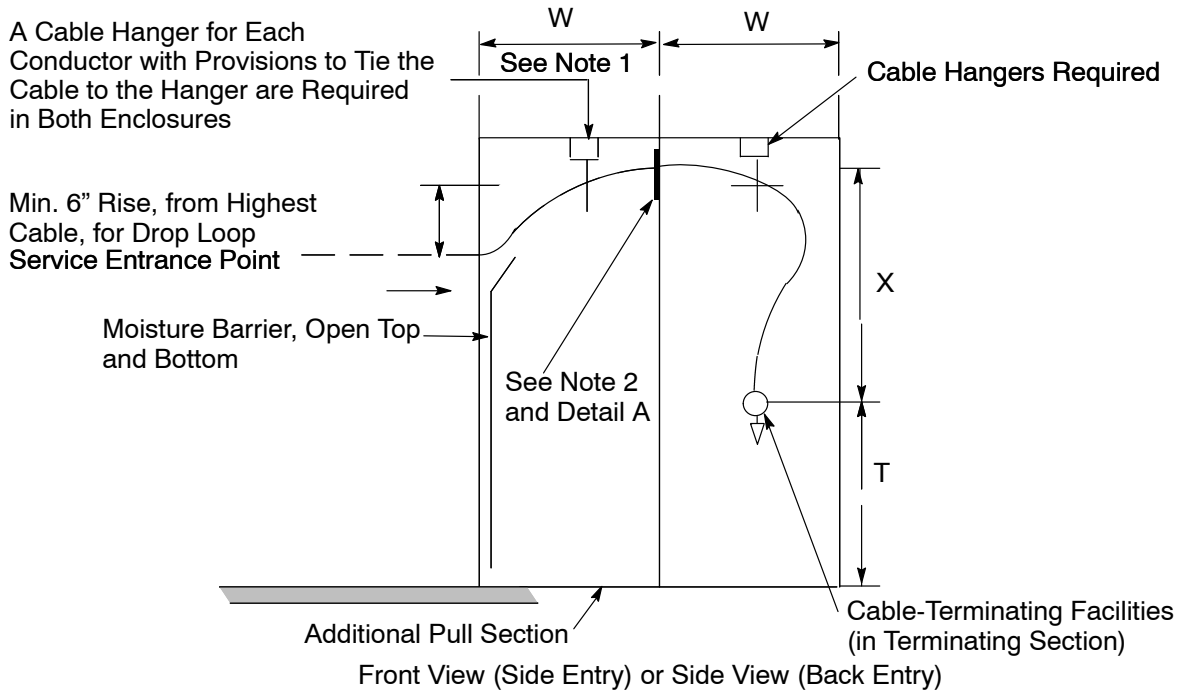
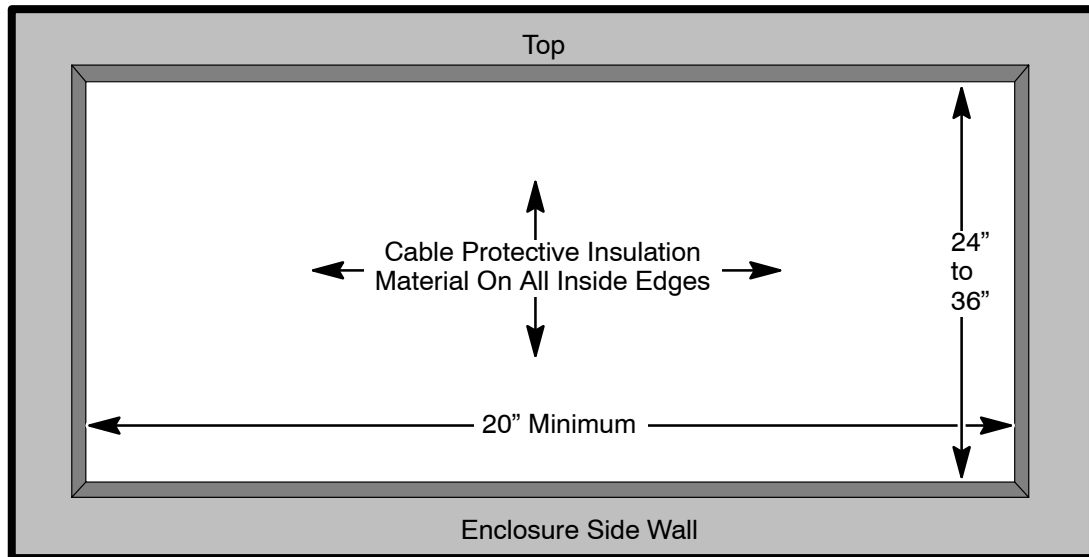

Figure 10-19
Additional Side or Back Switchboard Pull Section, High Entry

Notes in reference to Figure 10-19.

1. Ensure that the dimensions (i.e., width, depth, and height) of the additional pull section are exactly the same as the terminating section.
2. The height of the cable entrance window must be between 24 inches to 36 inches and the width must be a minimum of 20 inches. The edges of the window opening must be insulated to prevent damaging the cables. See Detail A, below.



Detail A - Cable Entrance Window

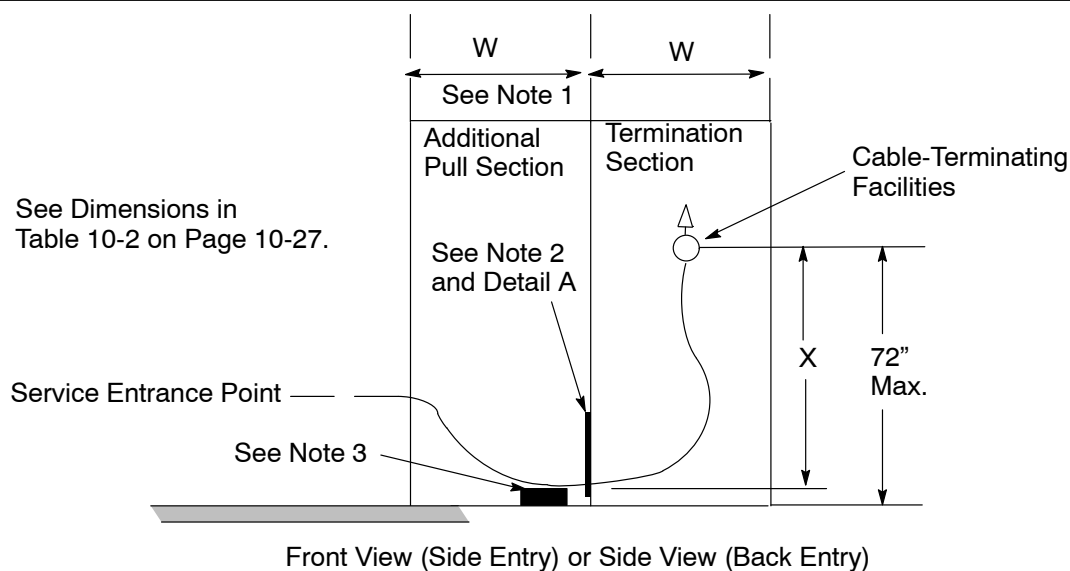

Figure 10-20
Additional Side or Back Switchboard Pull Section, Low Entry

Notes in reference to Figure 10-20.

1. Ensure that the dimensions (i.e., width, depth, and height) of the additional pull section are exactly the same as the terminating section.
2. The height of the cable entrance window must be between 24 inches to 36 inches and the width must be a minimum of 20 inches. The edges of the window opening must be insulated to prevent damage to the cables. See Detail A on Page 10-28.
3. Cables must not lie on the ground. The customer must provide a cable support system to keep the cables off of the ground. Otherwise cable blocks must be supplied using PG&E Material Code 362118.

10.3.14. Underground, Cable-Terminating Facilities in Pull Boxes or Pull Sections

Figure 10-21 through Figure 10-24, all on Page 10-32, provide diagrams and required dimensions for cable-terminating facilities in the pull boxes or pull sections. The following paragraphs describe the requirements for applicants who install these facilities. Applicants must:

- A. Ensure that one landing position per phase is available for each 400 amps of service capacity, as shown in Figure 10-21, “Landing Terminal Detail,” on Page 10-32. Also, applicants must ensure that provisions have been made for stacking lugs.
- B. Ensure that bolts are provided with nuts, flat washers, and pressure-maintaining spring washers.
- C. Ensure that all parts are plated to prevent corrosion.
- D. Ensure that bolts are secured in place unless working access is provided on both sides of the mounting bus. If both sides of the bus are accessible, one set of bolts may be used to provide two terminal-mounting positions, one on either side of the bus.

NOTE: “Secured in place” means the stud will not turn, back out, or loosen in any manner when subjected to normal, UL-approved torques while tightening or loosening terminal nuts. This includes cross-threaded situations.

- E. In the terminal-mounting area, ensure that a radial clearance of 1-1/2 inches is provided between any bus (including bolts) and any other bus (including horizontal cross-busing) or grounded surface, as shown in Figure 10-22, “Spacing Requirements,” on Page 10-32.

EXCEPTIONS: The following are exceptions from these requirements.

1. The minimum clearance to the back of the pull section or to the front of the pull-section cover may be 1 inch.
 2. The neutral bus or termination may have a minimum clearance of 1 inch from any grounded surface.
 3. Service cables passing over horizontal cross busing must have a minimum 2-1/2-inch radial clearance. This distance may be reduced to 1 inch if the horizontal bus is fully insulated.
- F. Ensure that each cable-mounting position has at least 8 inches of unobstructed space in front of the entire mounting surface when all of the conductors are in place. This space must be accessible from the front of the pull section.
- G. Ensure that the bus stubs are firmly secured to prevent bus misalignment and movement when the cables are installed. See Figure 10-23, “Buses Accessible From Only One Side (Bolts Must Be Secured in Place),” and Figure 10-24, “Buses Accessible From Either Side (Mounting Surfaces on Both Sides of Bus),” both on Page 10-32, for bus stub details through 2,500 amps.
- H. For nonresidential services, either single or three phase, 600 amps and above, PG&E requires applicants to install multiple sets of service conduit. Additionally, PG&E will require applicants to supply stacking lugs for terminating its cables in any installation that is rated nonresidential, three phase, 1,200 amps or greater.
- I. For nonresidential services, additional space (i.e., depth, width, and termination height) may be required in any section of switchboard, panelboard, or other enclosure used to terminate PG&E service cables. This additional space may be necessary to provide proper clearances between phases and grounded surfaces, as well as to accommodate the installation of service cable.
- J. Applicants should review [Numbered Document 063928](#), “Methods and Requirements for Installing Commercial Underground Electric Services 0–600 Volts to Customer-Owned Facilities,” for the appropriate conduit and cable requirements for nonresidential service installations. Find this document in [Appendix C](#). “Electric and Gas Engineering Documents.”

- K. PG&E does **not** allow applicants to install wall-mounted cable termination and pull enclosures for nonresidential, three-phase installations rated at 401 amps through 2,500 amps. For those installations, PG&E requires a switchboard pull section or enclosure meeting the requirements shown in Table 9-4, “Minimum Pad-Mounted (Floor-Standing) Switchboard Pull-Section Dimensions: Residential and Nonresidential, Single-Phase and Three-Phase,” on Page 9-11, and Table 10-1, “Minimum Bottom-Fed Pull-Section Dimensions,” on Page 10-24, for bottom entry. Also, see Table 10-2, “Pull Section Dimensions (Minimums) Below Ground Level,” on Page 10-27, for side or back entry.
- L. See additional requirements in Section 9.10., “Underground Service Cable-Termination Section or Pull Box,” on Page 9-10. The information, tables, and figures provide additional requirements for applicants who install wall-mounted and pad-mounted cable-termination and pull-section equipment.

NOTE: The utility point of service (i.e., service point) is defined as the approved enclosure and the terminated or spliced connections.

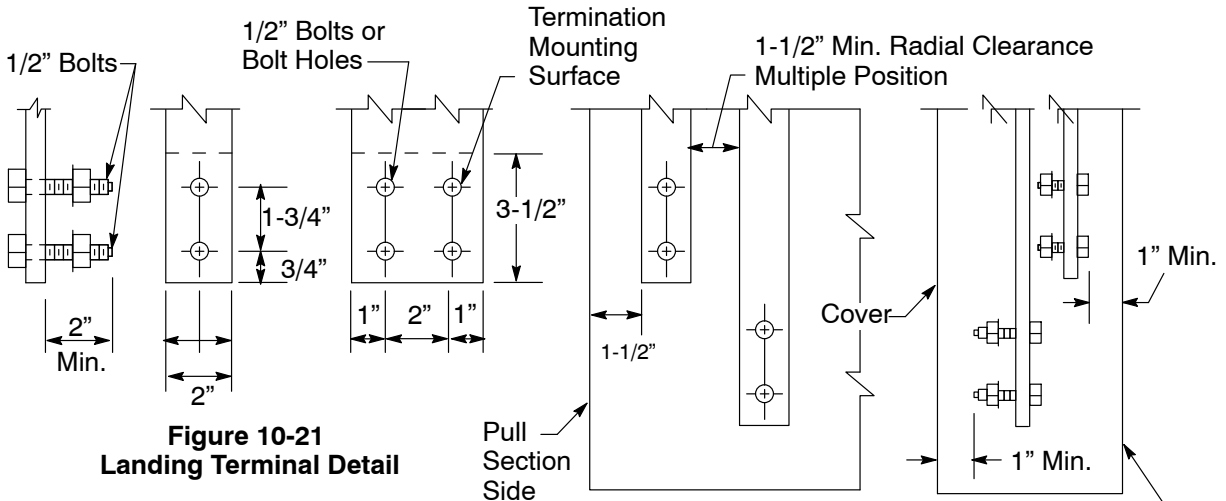

Figure 10-21
Landing Terminal Detail

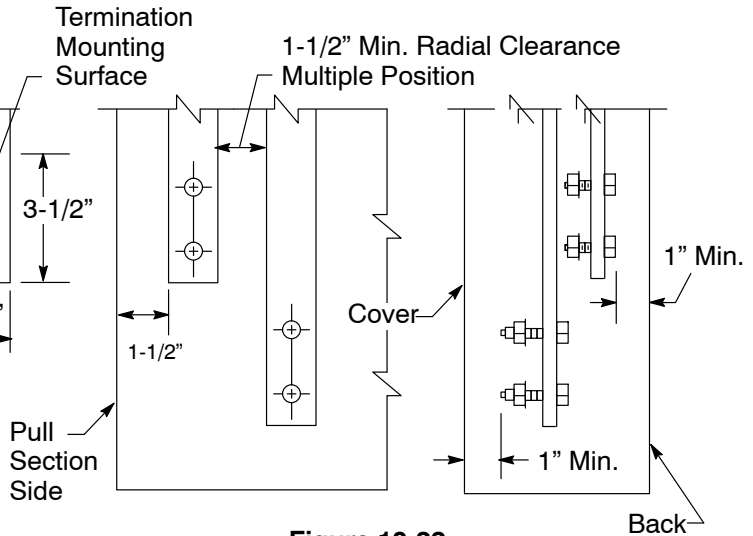

Figure 10-22
Spacing Requirements

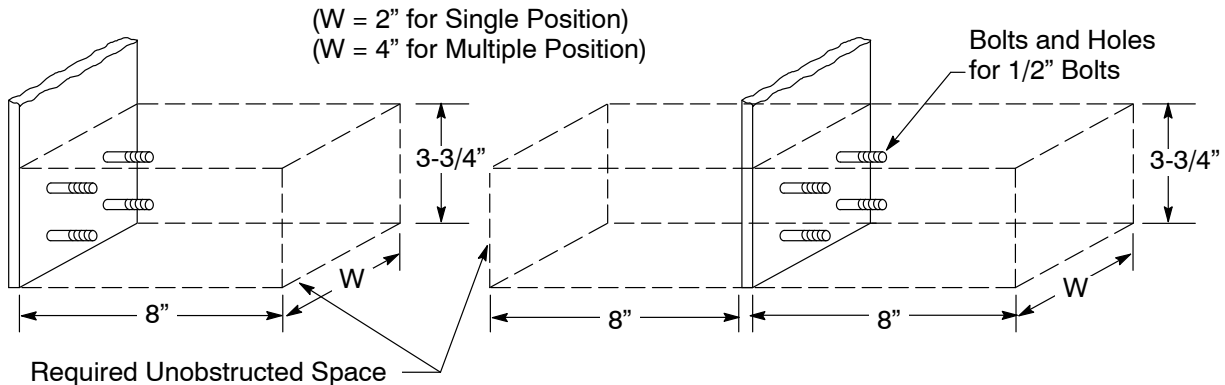

Figure 10-23
Buses Accessible From Only One Side
(Bolts Must Be Secured in Place)

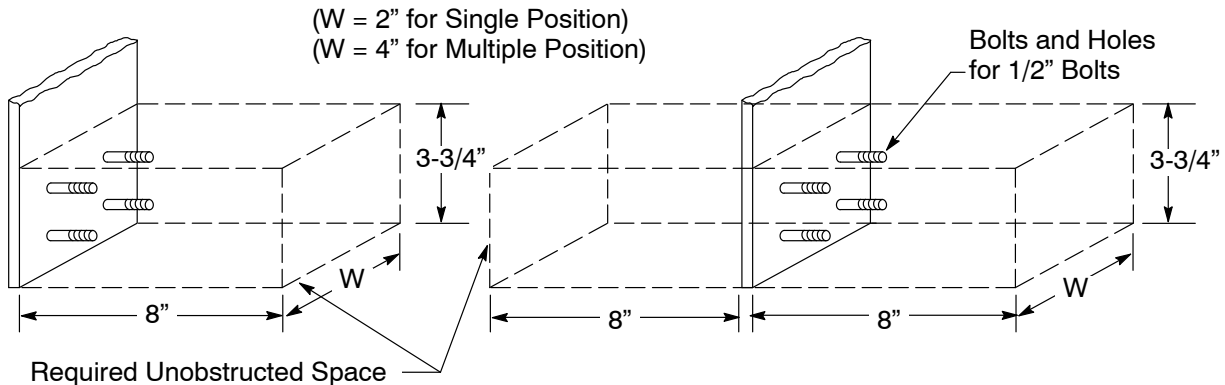

Figure 10-24
Buses Accessible From Either Side
(Mounting Surfaces on Both Sides of Bus)

10.4. Meter and Switch Sequence Requirements

PG&E will locate meters and metering equipment ahead of (i.e., on the supply side) the applicant's main switch and fuse or circuit breaker. Exceptions to this normal sequence are permitted only when required by electric codes and as allowed by PG&E.

10.5. Metering Transformer Compartments

The following requirements apply to applicants who are installing metering transformer compartments.

- A. Bus the CT compartments using a rectangular bus bar. See Figure 10-1 through Figure 10-7 on Pages 10-6 through 10-15 for more information.
- B. Ensure that the covers for metering transformer compartments are:
 - Constructed of 12-gauge steel (minimum).
 - Provided with lifting handles.
 - Attached with sealable studs and wing nuts or using other approved means.
- C. Use a copper or aluminum bus bar on both the line sides and load sides of all CTs. When links and supports are required for through-type CTs, ensure that the bus and removable links are constructed of a compatible material.
- D. Do **not** use PG&E's CTs for any purpose but metering.
- E. Do **not** use the metering transformer compartment as a splicing or tap-making chamber.
- F. Do **not** use the bolts required for connecting a CT to attach other conductors.

10.6. Meter Panels

The following requirements apply to applicants who are installing meter panels.

- A. Except for remote metering enclosures, use **only** hinged meter panels in front of a metering transformer compartment. The meter panel must be hinged next to the test facilities.
- B. Ensure that the dual-socket metering panel is provided in switchboards supplying a demand load of 400 kilovolt amperes (kVA) or more. See Table 10-3, "Dual-Socket Hinged-Meter Panel Requirement," below. Provide two 15-inch panels, shown in Figure 10-27 on Page 10-36, or one 30-inch panel, shown in Figure 10-28 on Page 10-37.
- C. Ensure that meter panels are constructed of 12-gauge steel (minimum) and are sealable, hinged, and reversible. Because the meter panels are reversible, the hinges can be used on either the right side or the left side of the panels.
- D. Note that the width of meter panels may sometimes require the service section to be wider than the minimum-allowable width of the transformer compartment.
- E. Mount self-contained meters on nonhinged panels, as shown in Figure 10-12 on Page 10-22.

Table 10-3 Dual-Socket, Hinged, Meter-Panel Requirement

Service Voltage	Switchboard Supply Rating	Panel Required
277/480V 3Ø, 4-Wire	401 Amps and Above	Yes
120/240V 3Ø, 4-Wire	801 Amps and Above	Yes
120/208V 3Ø, 4-Wire	1,001 Amps and Above	Yes

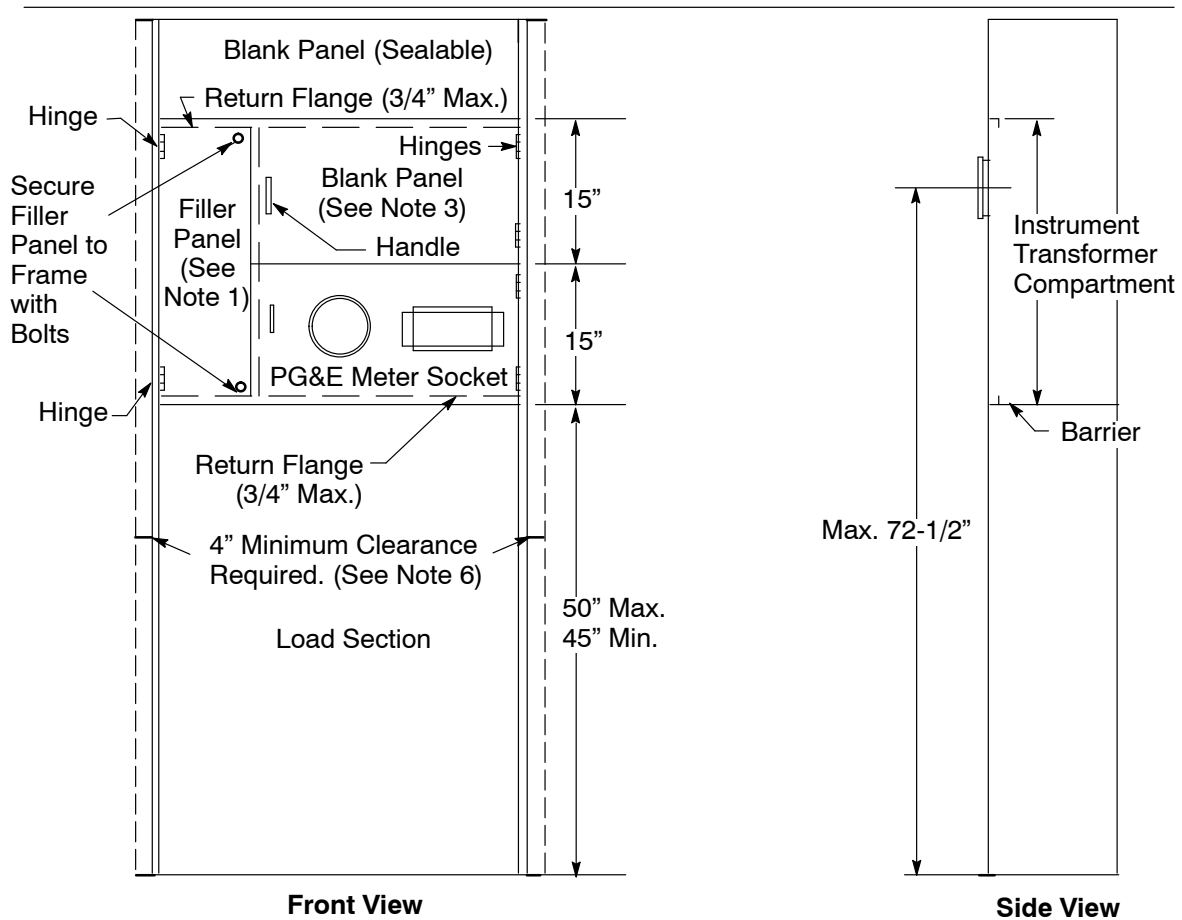

Figure 10-25
Standard Switchboard Service Section With CT Compartment and Filler Panel,
0 Volts-600 Volts

Notes in reference to Figure 10-25.

1. Use filler panels where the switchboard width exceeds the allowable meter panel width. It is allowed to hinge meter panels to hinged filler panels only if the filler panel is bolted to the switchboard in both corners of the filler panel opposite the hinges.
2. Make the grounding connection in the main switch or breaker compartment.
3. In a split-panel arrangement, mount the kilowatt-hour (kWh) meter panel in the lower position.
4. Equip meter panels and filler panels with stops to prevent the panels from swinging inward beyond the front surface of the switchboard.
5. Ensure that all panels and covers are sealable.
6. Ensure that the meter panels can open 90° with the meter and test facilities in place. Ensure there is at least 4 inches of minimum clearance on the side where the meter panel door opens outward.

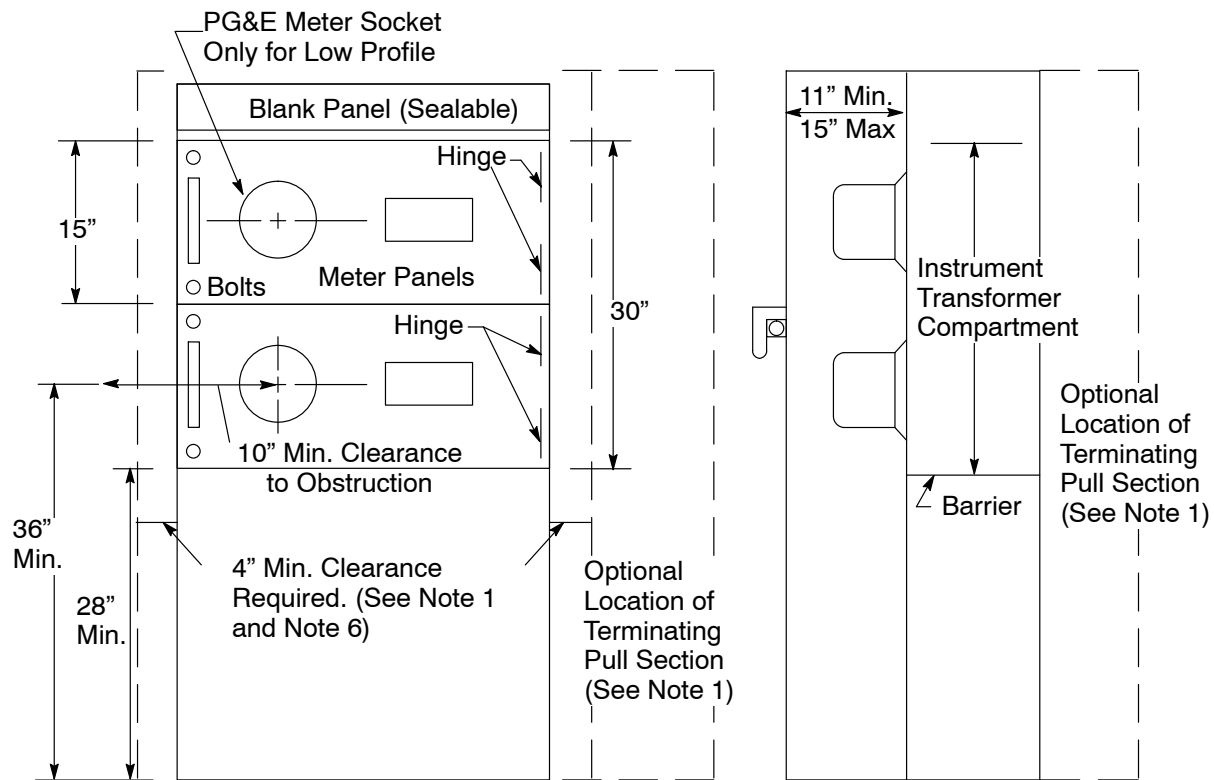

Figure 10-26
Low-Profile Switchboard Service Section With CT Compartment for Underground,
Outdoor Application, 0 Volts-600 Volts

Notes in reference to Figure 10-26.

1. Locate the terminating pull section beside or behind the instrument compartment.
2. Use filler panels where the switchboard width exceeds the maximum-allowable meter panel width. It is allowed to hinge meter panels to hinged filler panels only if the filler panel is bolted to the switchboard in both corners of the filler panel opposite the hinges.
3. Make the grounding connection in the main switch or breaker compartment.
4. Equip meter panels and filler panels with stops to prevent the panels from swinging inward beyond the front surface of the switchboard.
5. Ensure that all panels and covers are sealable.
6. Ensure that the meter panels can open 90° with the meter and test facilities in place. Ensure there is at least 4 inches of minimum clearance on the side where the meter panel door opens outward.
7. Only for low-profile switchboards. Place the PG&E meter socket on the top panel.

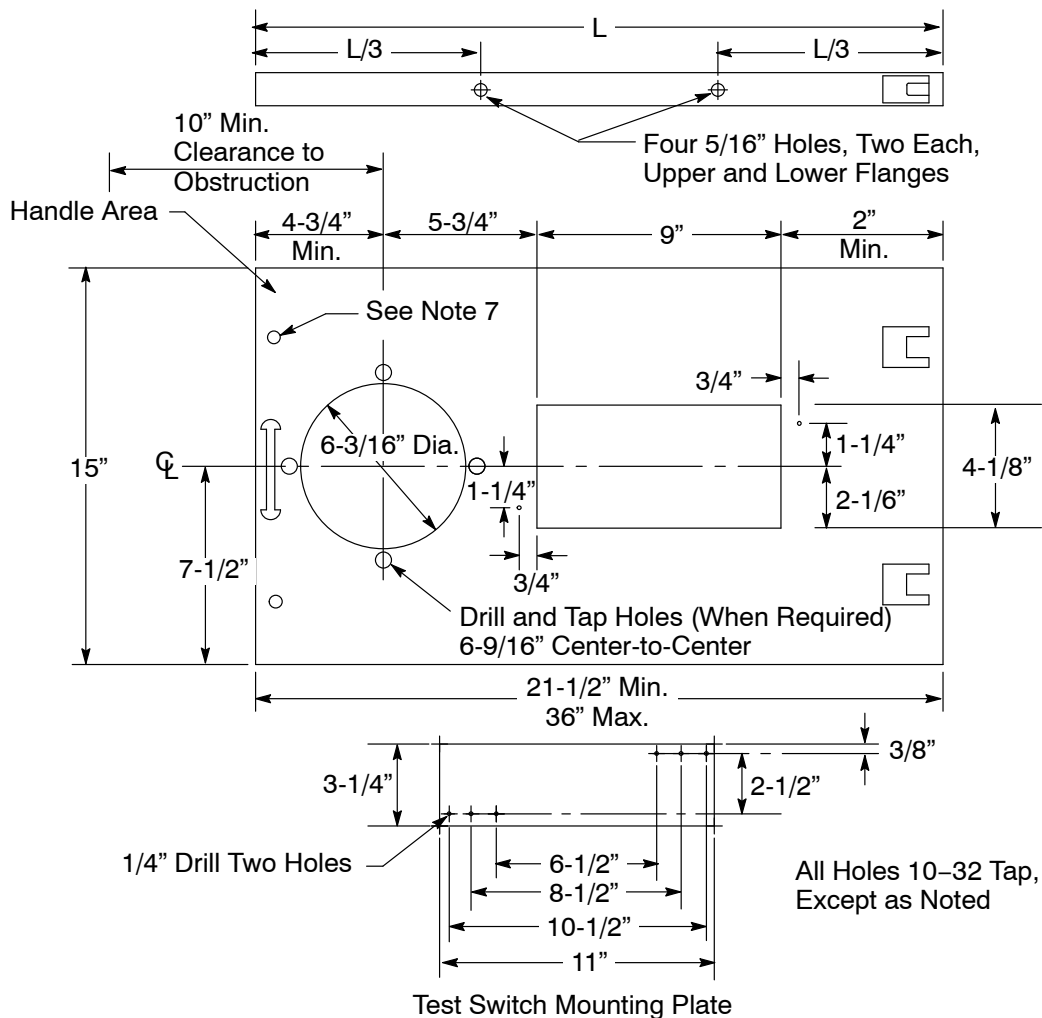

Figure 10-27

Standard Switchboard Service Section, 15-Inch Hinged Panel for Socket Meter and Test Switch

Notes in reference to Figure 10-27.

1. Ensure that the switchboard manufacturer drills, taps, and slots the panel for the secondary test switch, as shown. Also, ensure that the switchboard manufacturer furnishes and installs the socket with a sealing ring.
2. Design the meter sockets to be installed on hinged panels for back (rear) connection.
3. Use the outdoor or rain-tight enclosures shown in Figure 10-29 through Figure 10-31 on Page 10-38.
4. Attach a handle at the unsupported end of the meter panel. Leave a minimum clearance of 1 inch from the handle to the meter socket.
5. Ensure that hinges can support a 25-pound load applied at the unsupported end with a maximum 1/8-inch sag when the panel is open.
6. Secure removable plates to the rear of the panel using screws that do **not** protrude through the face of panel.
7. Ensure that the meter panels can open 90° with the meter and test facilities in place.
8. Ensure that all securing screws and sealing screws on the panels are captive. Studs and wing nuts must be sealable, when they are used.
9. Ensure that hinges are interchangeable and can be used on either the right side of the left side of the meter panels. When using clevis-type or removable pin-type hinges, ensure that the pin can be removed from the type of the meter panel.

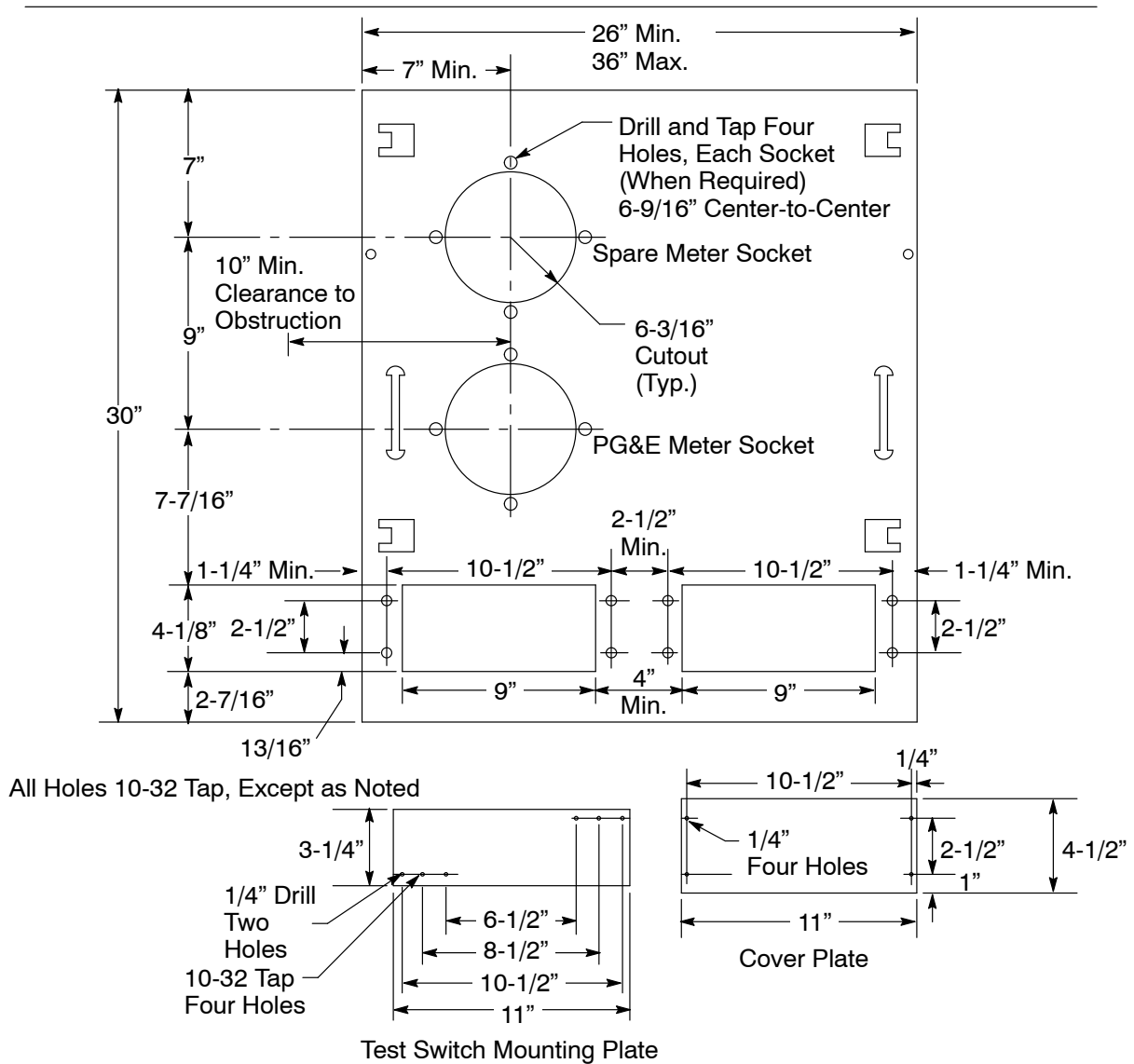

Figure 10-28
Standard Switchboard Service Section, 30-Inch Panel for Socket Meters and Test Switches

Notes in reference to Figure 10-28.

1. Meter socket openings may be on either the right or the left side of the panel.
2. Ensure that the switchboard manufacturer drills, taps, and slots the panel for the secondary test switch, as shown. Also, ensure that the switchboard manufacturer furnishes and installs the socket with a sealing ring.
3. Paint the removable plates and attached them to the panel.
4. Construct meter panels of 12-gauge steel (minimum). Ensure they are hinged and sealable.
5. Ensure that hinges are interchangeable and can be used on either the right side or the left side of the meter panels. When using clevis-type or removable pin-type hinges, ensure that the pin can be removed from the top of the meter panel.
6. Ensure that hinges can support a 25-pound load applied at the unsupported end with a maximum 1/8-inch sag when the panel is open.
7. It is allowed to hinge meter panels to hinged filler panels only if the filler panel is bolted to the switchboard in both corners of the filler panel opposite the hinges.

Notes in reference to Figure 10-28, continued.

8. Ensure that a hinged meter panel can be opened 90° with the meter and test facilities in place. When working with either recessed or enclosed meter panels, see Figure 10-29 below.
9. Ensure that the panel has a handle attached on both sides.
10. All securing screws and sealing screws on the panel must be captive. Stud and wing nuts must be sealable, when they are used.
11. Design the meter sockets to be installed on hinged panels for back (i.e., rear) connection.
12. For panel widths of less than 26 inches, consult your local PG&E meter shop.

10.7. Transformer-Rated and Self-Contained Switchboards

Applicants may use switchboards consisting of a main disconnect (if required), individual meter sockets, and associated circuit breakers or switches for individually metered, multiple occupancies supplied from one service. Figure 10-29, Figure 10-30, and Figure 10-31, below, show standard switchboard service-section detail for transformer-rated meter sockets. Figure 10-32, below, shows standard switchboard service-section detail for self-contained meter sockets rated from 0 amps through 225 amps.

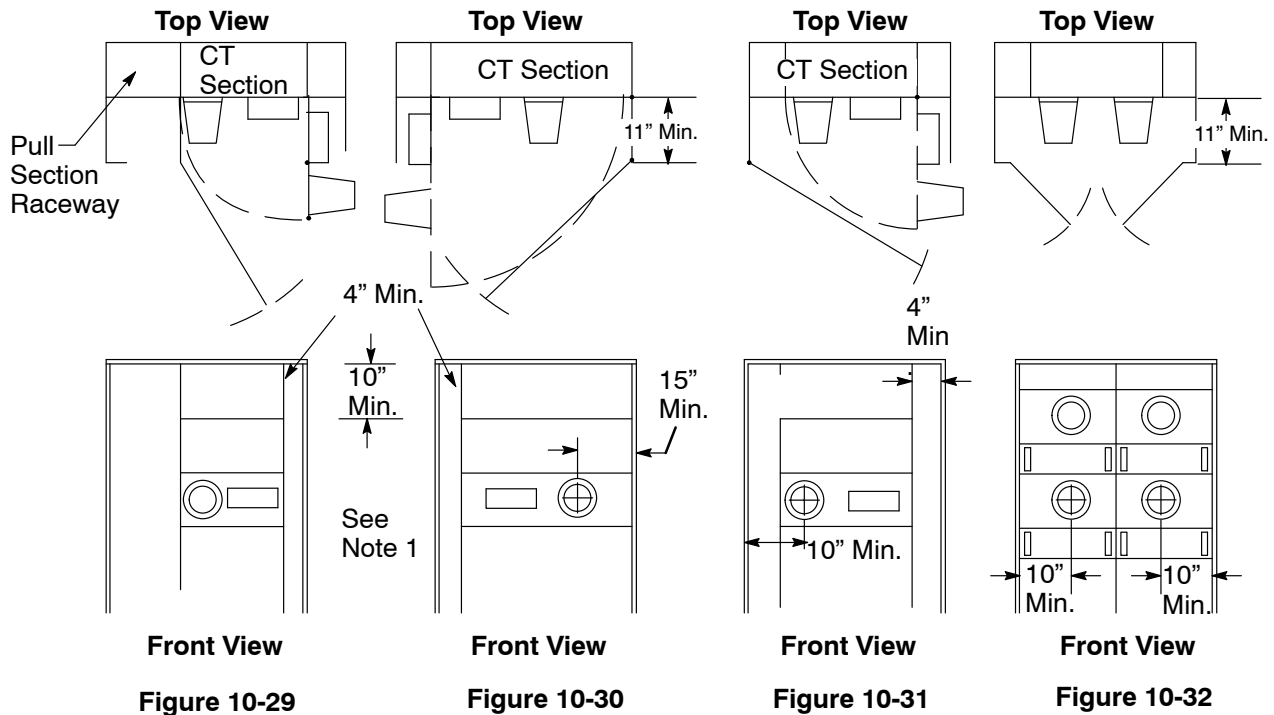

Outdoor or Rain-Tight Enclosures for Switchboards

Notes in reference to Figure 10-29, Figure 10-30, Figure 10-31, and Figure 10-32.

1. Ensure that hinged meter panels and enclosure doors can be opened at least 90° with meter and test facilities in place.
2. For hinged meter panel designs, see Figure 10-25 on Page 10-34 and Figure 10-26 on Page 10-35.
3. Ensure that enclosure doors can be secured in the 90° open position.
4. For approved enclosure-locking provisions, see [Section 5](#), Subsection 5.3.4., "Electric Meter Rooms," on Page 5-8.
5. Ensure that outdoor or rain-tight enclosures are used.

10.8. Adding New Metering Equipment to Existing Switchboards

When applicants want to install a new meter panel or meter section and connect to the load side of an existing switchboard, the required method is to extend the bussing from the last meter section of the existing switchboard into the new meter section. Please contact the local project coordinator before interconnecting and adding load. Project coordinators must ensure that the existing PG&E facilities are upgraded, when necessary.

If the new meter panel or meter section cannot be connected to the end of the switchboard, the interconnection may be allowed, at PG&E's discretion, in the utility termination section of the switchboard only if **all** of the following conditions below are met.

- A. The total aggregated ampacity of the new panel or new section plus the existing switchboard metering sections is **not** greater than the existing switchboard's total (supply) ampacity rating. See Table 10-4, "Adding Up Meter Section Ampacities," and Figure 10-33, "Existing Switchboard," both on Page 10-40, to calculate the ampacities.
- B. PG&E calculates the new total demand load and, if needed, installs the additional service conductors required to meet that load. A larger transformer may also be required because of the new total demand load.
- C. PG&E identifies available spare landing positions on the terminating facilities. The spare landing positions are in addition to the number of landing positions required in Subsection 10.3.14., "Underground, Cable-Terminating Facilities in Pull Boxes or Pull Sections," on Page 10-29, that must be reserved for existing and future installation of additional cables.
- D. The utility service termination section (typically 90 inches high) does not contain a main breaker compartment or a metering compartment. This termination section is dedicated only for terminating PG&E service cables. See Figure 10-33, "Existing Switchboard," on Page 10-40.

If all of the conditions described above are met and PG&E approves the installation of the new meter panel or meter section, applicants must follow the applicable instructions provided in Item E. and Item F. below.

- E. Overhead Service: Applicants must locate the taps in a sealable compartment that is located above and separated from the CT and/or metering equipment compartment.
- F. Underground Service: Applicants must ensure that the taps are located in the underground service-termination pull section or pull box. In this instance, the applicant must ensure that the bus conductors terminate in a suitable, approved manner. Also, the applicant must ensure that the bus conductors are positioned so that the customer's incoming, service-entrance conductors and the tap connections do not encroach into PG&E's pulling area or interfere with PG&E's pull and termination facilities for service-lateral conductors.

NOTE: Due to various types of configurations and arrangements of switchboard compartments in some termination sections, the interconnection may not meet all of the requirements listed above and will be denied. One example is when the PG&E metering compartment or the customer's main breaker compartment is directly above the utility termination section. See Figure 10-25 on Page 10-34.

Table 10-4 Adding Up Meter Section Ampacities¹

Example	Supply Section Ampacity Rating	Meter Section #1 Ampacity Rating	Meter Section #2 Ampacity Rating	Aggregated Ampacity of All Metering Selections	New Meter Equipment Tap Allowed?
1	2,000	1,200	800	$1,200 + 800 = 2,000$	No. Column 5 is not less than Column 2.
2	2,000	1,000	600	$1,000 + 600 = 1,600$	Yes. Column 5 is less than Column 2. A new meter panel ≤ 400 amps is allowed.

¹ Only two meter sections are shown as an example. Add up the ampacities for all meter sections and meter panels connected to the switchboard.

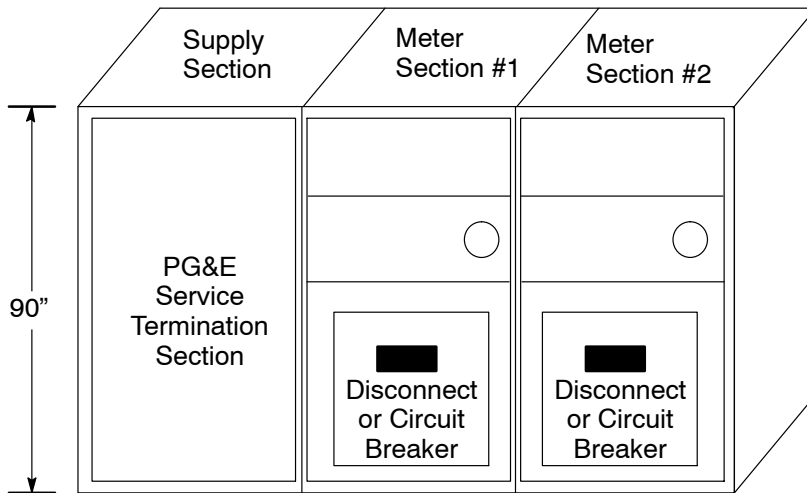

Figure 10-33 Existing Switchboard

**SECTION 11
ELECTRIC SWITCHBOARDS:
601 THROUGH 25,000 VOLTS**

**SECTION 11 ELECTRIC SWITCHBOARDS: 601 THROUGH 25,000 VOLTS
AND PRIMARY SERVICES**

Section 11

Electric Switchboards: 601 Volts Through 25,000 Volts and Primary Services

11.1. Scope

This section of the manual provides application and installation details for high-voltage switchboard metering equipment ranging from 601 volts through 25,000 volts.

11.2. General Requirements

The following general requirements apply when installing high-voltage electric switchboards and primary services.

Find reference information for interconnections and primary services in Subsection 11.4., “Interconnection Requirements and Primary Services,” on Page 11-10.

- A. The specific switchboards voltages represented in this section are:
- 2,400
 - 4,160
 - 12,000
 - 17,200
 - 20,780
- B. Applicants must ensure that manufacturers contact PG&E **before** fabricating the switchboards and request the specific information listed below.
- Service voltage, phase, and wiring.
 - Meter panel requirements for the applicable rate schedule.
 - Service-termination location.
 - Switchboard and/or meter location.
 - Size and number of service conductors.
 - Other information and specifications necessary for fabricating switchboards (e.g., [Equipment Utility Service Requirements Committee \[EUSERC\]](#) manual, Section 400 requirements).
- C. A manufacturer must submit three sets of drawings of the proposed equipment to PG&E for pre-approval **before** manufacturing the equipment. The drawings must include the contractor’s name and address, the applicant’s name, and the job location. Field-design changes are **not** permitted without obtaining PG&E’s approval before making the changes.

NOTE: Employees perform a field inspection of the switchboard at the jobsite. The switchboard is approved only when it meets all of the specified requirements.

D. PG&E must furnish and install fuses for voltage transformers (VTs), as well as for the following equipment.

- Meters
- Metering transformers
- Test switches
- All secondary wiring from the metering transformers to the meters

When more than one switchboard is required, install a separate service section. Ensure that it is separated completely (i.e., barriered) from other service sections, pull sections, or service switches and disconnects.

11.3. Specific Requirements for High-Voltage Switchboards

The applicant must ensure that the equipment described below is provided and that the included construction requirements are followed precisely when installing high-voltage switchboards.

- A. Provide and install the insulation barrier between the potential transformer (PT) disconnect switches and the PT section. The voltage disconnect switch handle **must** be visible when the outer door of the switchboard is opened.
- B. Ensure that the insulated cables and conductors are made available to PG&E. PG&E personnel will make the connections between the PT fuse holders and metering PTs. Use only the “no-load” types of PT disconnect switches.
- C. Provide individual pulling eyes above each of the current transformer (CT) positions to aid CT lifting.
- D. Ensure that all ground buses are solid bus bars with dimensions of at least 1/4 inch x 2 inches. Ground buses must be constructed from either **copper** or **aluminum**.
- E. Do **not** use flex braid on any section of ground buses.
- F. Ensure that a ground bus bar is used for the PT disconnect.
- G. Ensure that ground buses do **not** obstruct internal compartments, openings, conduits, or accesses to utility facilities, equipment, or extended work areas.
- H. Ensure that the ground bus is located in front of the panel to provide better accessibility for any work to be performed. This includes the PT section.
- I. Only use a gang-operated disconnect. The disconnect must have grounds in a blade-and-jaw configuration when it is opened. Do **not** use fused-drawer disconnect devices or fused, removable, section-type disconnect devices.
- J. Ensure that workspaces and clearances meet the required state and local codes. **Ensure that there is an unobstructed, 8-foot area cleared in front of all access doors.** This area is required for installing and removing PG&E’s safety grounds. Maintain this clearance area at all times.
- K. Concrete floors or pads must extend out in front of the whole area a minimum of 96 inches, as measured from the outside of the equipment’s outer doors. See the requirements in Section 5.4.4., “Working Space,” on Page 5-12.

- L. Ensure that three neutral lugs are provided in the PT section. Use these lugs to terminate the neutral circuit connected to the ground bus in the CT compartment. The lugs should accept a wire range between #6 to #10.
- M. Ensure the requirements in [Section 5](#), “Electric Metering: General,” Subsection 5-2, “Applicant Responsibilities,” are followed.
- N. Ensure that permanent marking or labeling, indicating the service voltage being supplied, is included on all electric meter panels and all equipment doors or panels that provide access to the service terminations, PTs, and CTs.
- O. Provide a bare bus that is 4 inches above **and** below the CTs. PG&E will use this bare bus as a safety ground.
- P. Ensure that the primary taps for the PTs are connected only to the line side of the metering CTs.

Another alternative allows applicants to mount the meter panel in front of the CT termination compartment if, when the meter panel is open, the compartment is isolated fully by a removable or hinged barrier. This barrier must be sealable using stud and wing assemblies.

- Q. To attach the safety grounds, install ball studs (1/2-inch through 13-inch threads with insulating covers) on the line and load side of the CT bus units. Locate the studs less than 7 inches from the end of the bus unit and orient them toward the compartment access opening. Also, install two ball studs on the ground bus inside the CT compartment.
- R. For the PT disconnect switch, apply a label stating “Meter & PT Disconnect Switch. Does Not De-Energize Load.” Ensure that the maximum amount of operating force required to open and close a PT disconnect switch is no more than 50 foot-pounds.
- S. **Install 2 ground rods and conduits for the primary service as shown in Figure 11-1, “Primary Switchboard Termination Section Pad Detail,” on Page 11-4.** These two ground rods are in addition to others already installed for the switchboard.
- T. Submit a termination section drawing detail on all of the switchboard drawings submitted to PG&E. The drawing detail should show the position of the conduit(s), ground rods, and additional internal components. Refer to Figure 11-1 on Page 11-4.
- U. Install a transparent, insulated, inner door as a safety barrier in front of the termination section, and CT section (if separate), for all switchboards 601 volts through 25,000 volts. Construct the safety door from a solid piece of clear acrylic that is a minimum 6 millimeters (or 1/4 inch) thick and resistant to damage by impact or puncture. Ensure the acrylic is rated for the voltage served. The safety door must extend from the top to the bottom of the section. Cover all energized parts on the switchboard and maintain all clearances. The acrylic door must be operable with hinges on one side, and a handle and provisions to secure the door in the open and closed positions on the opposite side. **Identify the door on all switchboard drawings submitted to PG&E.**
- V. An interlocking system is required to ensure the PT disconnect is locked open fully before the PT compartment door can be opened and entered.

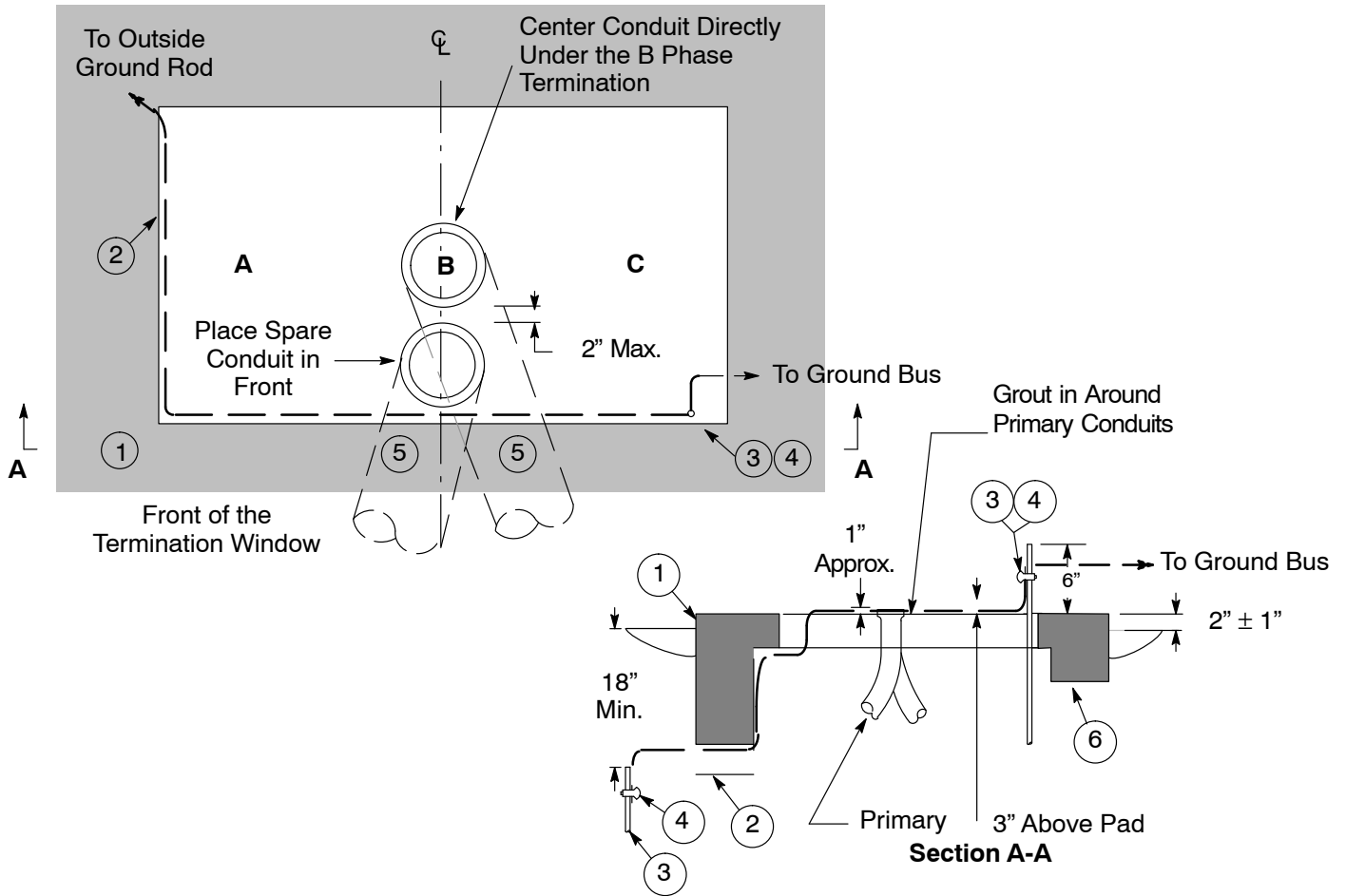

Figure 11-1
Primary Switchboard Termination Section Pad Detail

Notes in Reference to Figure 11-1.

1. Primary conduits must be centered in the window, as shown.
2. Maintain a 6-foot minimum separation between ground rods.
3. The ground wire must be a continuous wire that connects to and runs from the outside ground rod, under the pad, to the primary window. Then the wire must run above the pad, through the primary window, to the inside ground rod. Finally, the wire must run from the inside ground rod to the switchboard ground bus termination inside the termination section.

Table 11-1 Bill of Materials for Concrete Pad

Item	Quantity	Description	Code	Doc. No.
1	1	Pad, Concrete, Reinforced (size as required)	-	-
2	As required	Wire, #2 AWG, Solid, Soft Drawn, Bare Copper	-	-
3	2	Ground Rod, 5/8" x 8', Copperclad	187013	013109
4	2	Clamp, Ground Rod, for Item 3	187012	
5	As required	Conduit, Type and Size (as required)	-	062288
6	As required	Compacted Backfill	-	-

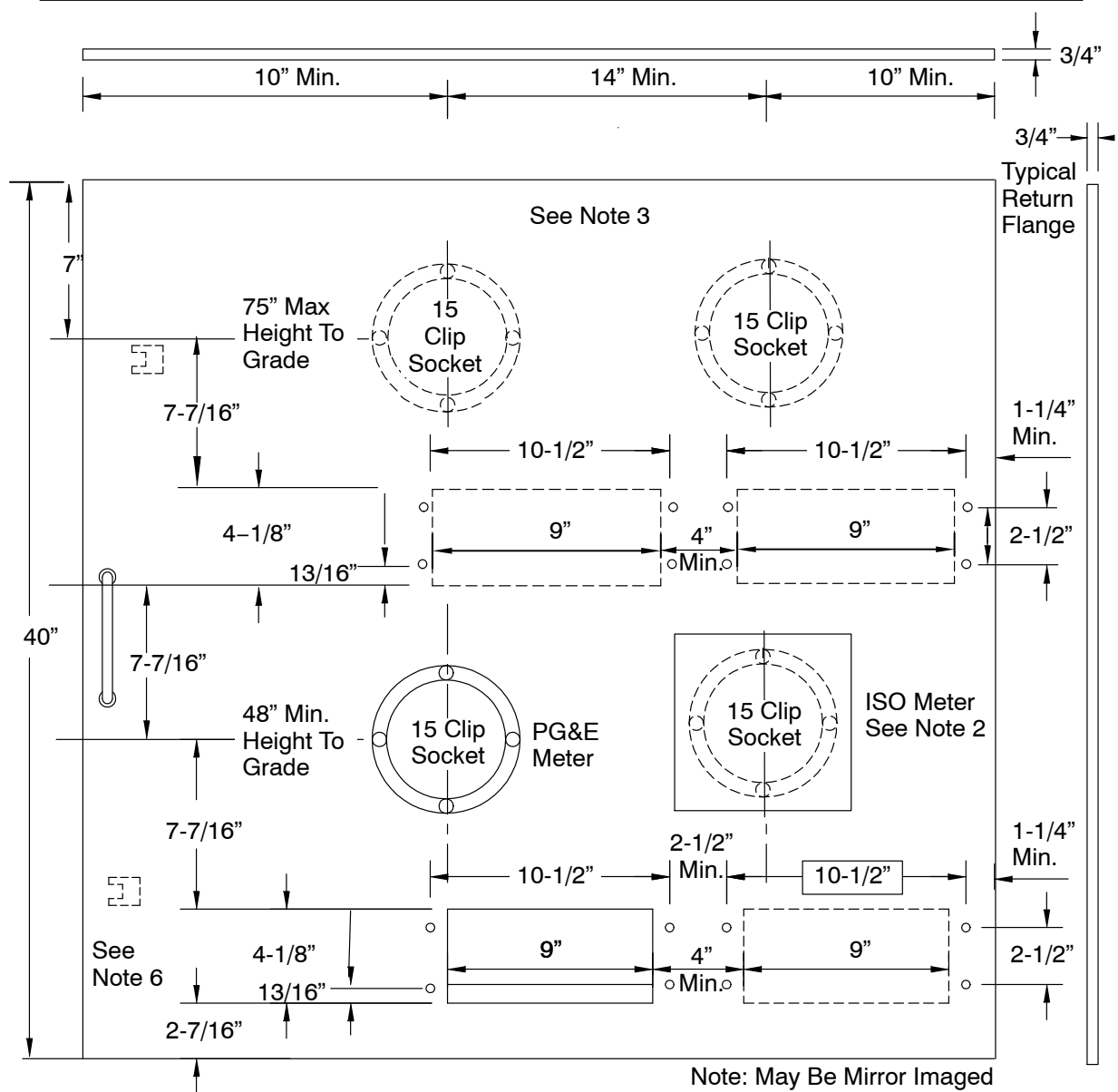

All Holes 10-32 Tap, Except as Noted

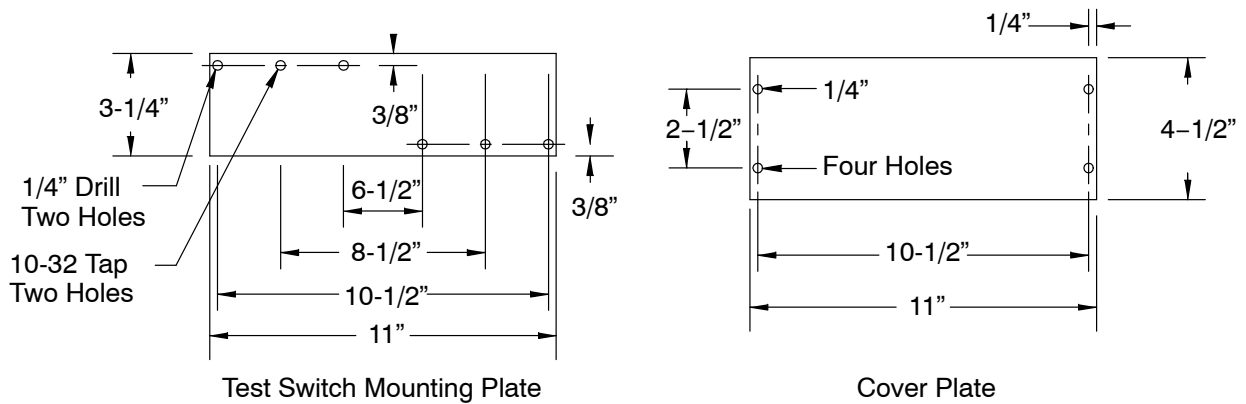

Figure 11-2
Hinged Meter Panel with Multiple Sockets for 2,400 to 27,000 Volt Service

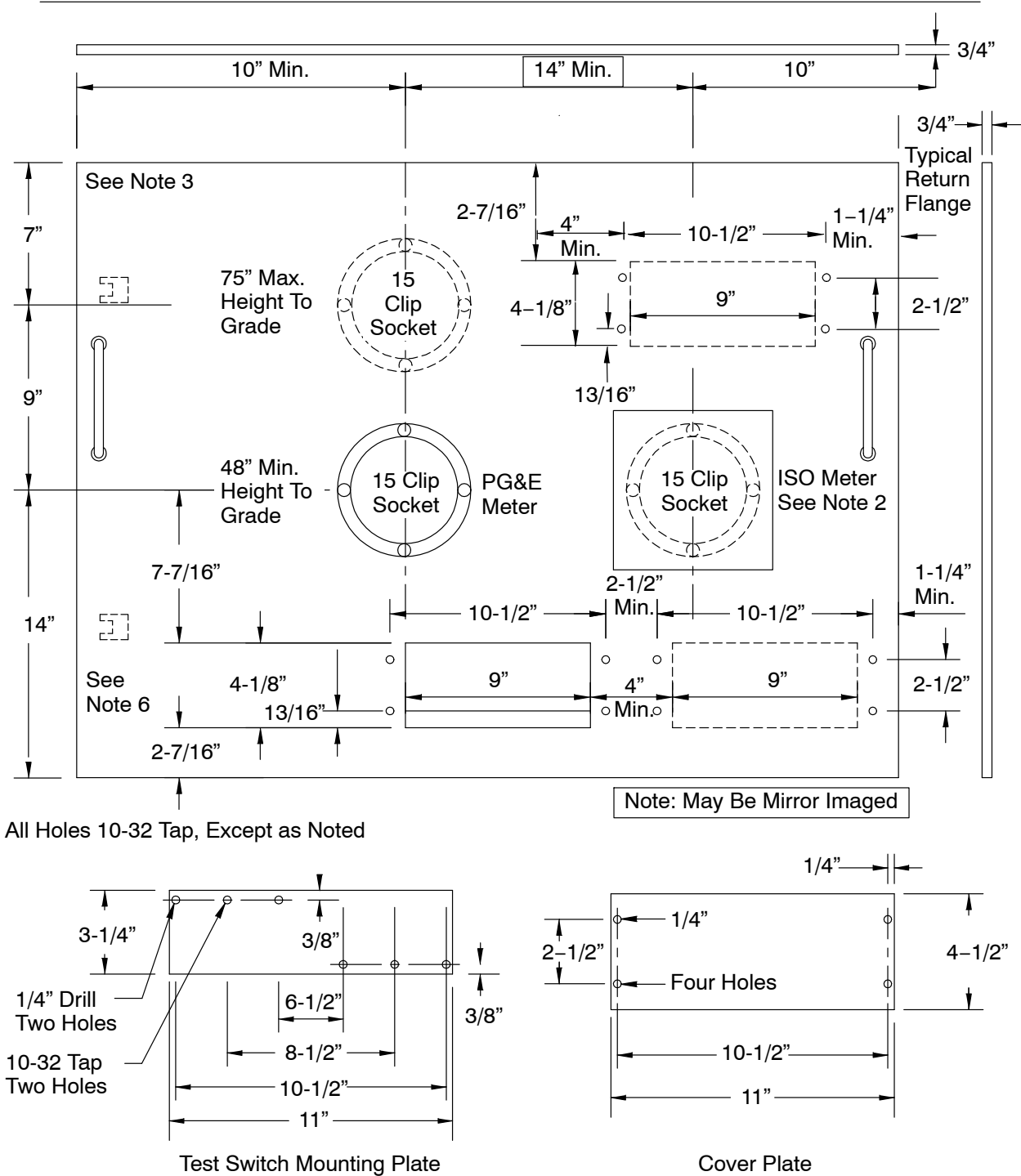

Figure 11-3
Hinged Meter Panel with Dual Socket for 2,400 to 27,000 Volt Service

Notes in reference to Figure 11-2 and Figure 11-3.

1. The panel must be constructed using 12 gauge (minimum) steel and furnished with meter sockets, sealing rings, slotted openings, and a removable plate for installing a secondary test switch. The slotted opening and removable plate edges must be smooth to prevent damaging the meter wiring.

Notes in reference to Figure 11-2 and Figure 11-3, continued.

2. Provide an ISO Meter Cast Ring Mounting Blank Cover. When a cast meter-mounting ring is provided, the screws used to attach to the meter panel must provide a minimum 1/8-inch clearance between the screw heads and the back of the ring.
3. Auxiliary power connections are not allowed.
4. The removable plates must be attached to the rear of the panel with screws that do not protrude through the face of the pane.
5. Meter sockets must be designed to connect from the back. A maximum of 4 meter sockets are allowed.
6. The panel must be equipped with hinges. The hinges must permit the panel to open to 90 degrees and be easily interchangeable, right or left, on the meter socket panel. Ensure that removable, pin-type hinges can be removed from the top. Hinges must be located on the same side as the PG&E meter socket.
7. When fully opened, the panel must support a 25-pound load applied at the unsupported end, with a maximum sag of 1/8 inch.
8. The panel must have a handle attached to both sides.
9. Stud and wing nuts must be sealable when used.
10. Consult PG&E before using a panel with a width of more than 38 inches.
11. Consult PG&E for meter-socket requirements.

Table 11-2 Dimensions for High-Voltage Meter Enclosures

Specifications	Switchboard Voltage Rating			
	2,400	4,160/4,800	7,200/17,000	20,800/25,000
	(In Inches)			
Minimum, Bare-Bus Clearance Ø to Ground	3-1/2	3-1/2	6	Refer to the Dimensions in Figure 11-5 on Page 11-9 and Figure 11-6 on Page 11-10.
Minimum, Bare-Bus Clearance Ø to Ø	5	5	7-1/2	
Dimension A	5 Min. 10 Max.	5 Min. 10 Max.	8 Min. 10 Max.	
Dimension B ¹	24 Min.	24 Min.	24 Min.	
Dimension C ¹	24 Min.	24 Min.	24 Min.	
Dimension D (Do not install neutral insulator)	–	–	–	
Dimension E ¹	36 Min.	48 Min.	60 Min.	
Dimension F	42 Min. 48 Max.	42 Min. 48 Max.	42 Min. 48 Max.	
Dimension G	36 Min.	36 Min.	36 Min.	
Dimension H Fuse-Mounting Clip: Center	8-1/2	8-1/2	11-1/2	
Dimension H Fuse Ferrule Diameter	1-5/8	1-5/8	1-5/8	
Dimension I To Bottom of Fuse Clip or Bus Extension (Whichever Is Lowest)	18	18	18	
Maximum Dimension J to Top of Fuse Clip or Bus Extension	30	30	30	

¹ Clearance to any part of the enclosure, including flanges and inner walls.

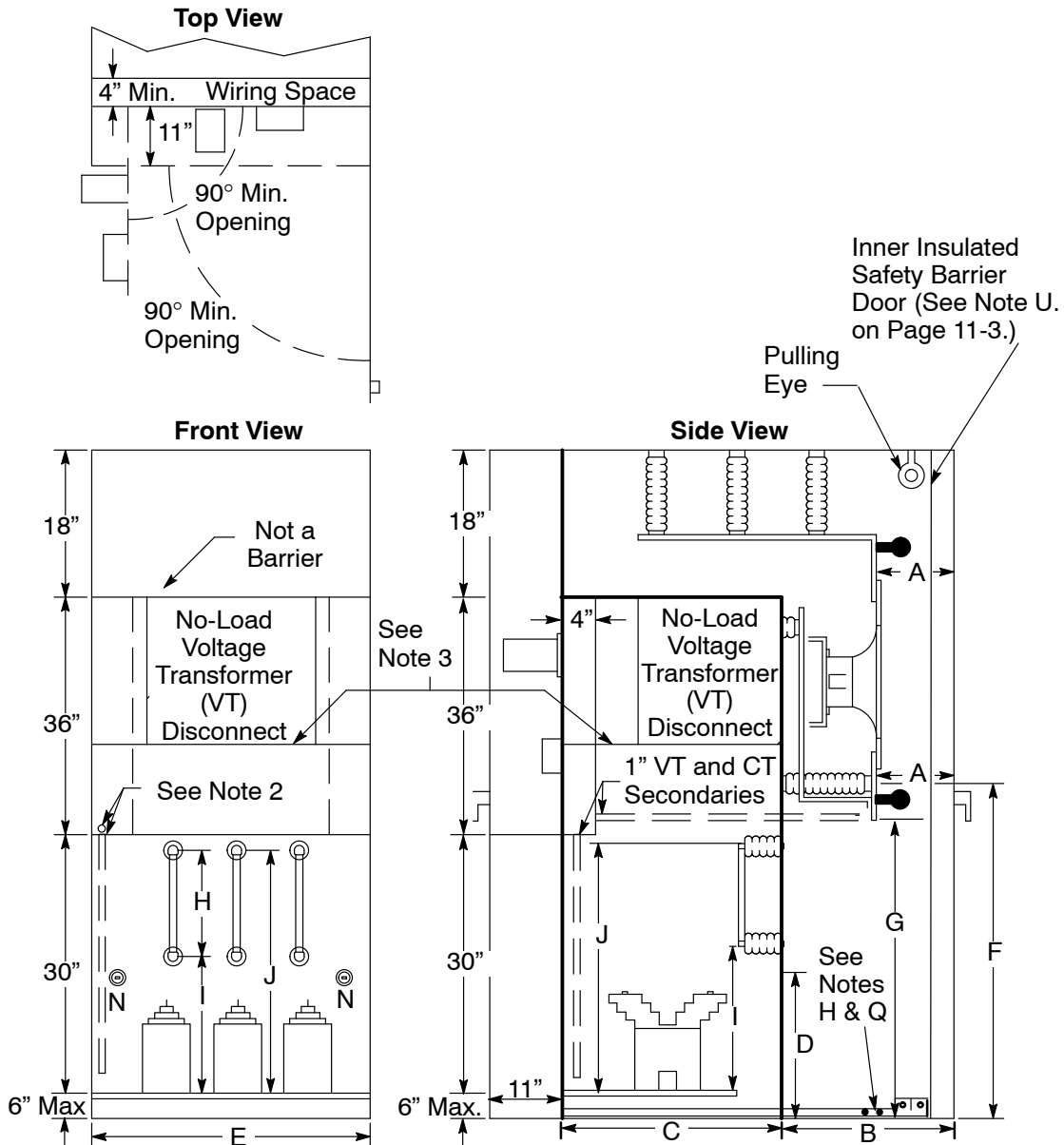

Figure 11-4
Typical, High-Voltage Metering Enclosure: 2,400-Volt Through 17,000-Volt Service

Notes in reference to Figure 11-4.

1. Install the meter's panel hinge on the opposite side from the enclosing door hinge on a weatherproof unit. This allows the meter panel to be opened a full 90°.
2. Locate the 1-inch, non-metallic VT and CT secondary conduits on the same side as the meter's panel hinges.
3. Electrically insulated barrier.
4. Applicants must ask the local project coordinator to contact the PG&E electric meter department to ensure that the types and models of instrument transformers they intend to install (i.e., VTs and CTs) are approved for use in high-voltage switchgear.
5. For VT Mounting rail materials and installation details, refer to the [EUSERC](#) manual, Drawing 407.
6. Ensure that the grounding bus extends on either the left or right sides of the CT compartment's access area. Also, ensure that the ground terminals are two aluminum-bodied mechanical lugs accepting a range of 6 American Wire Gauge (AWG) through 250 thousand circular mils (kcmil) conductors. Finally, ensure that they are identified with a label reading, "Safety Grounding Point For Utility Use Only."

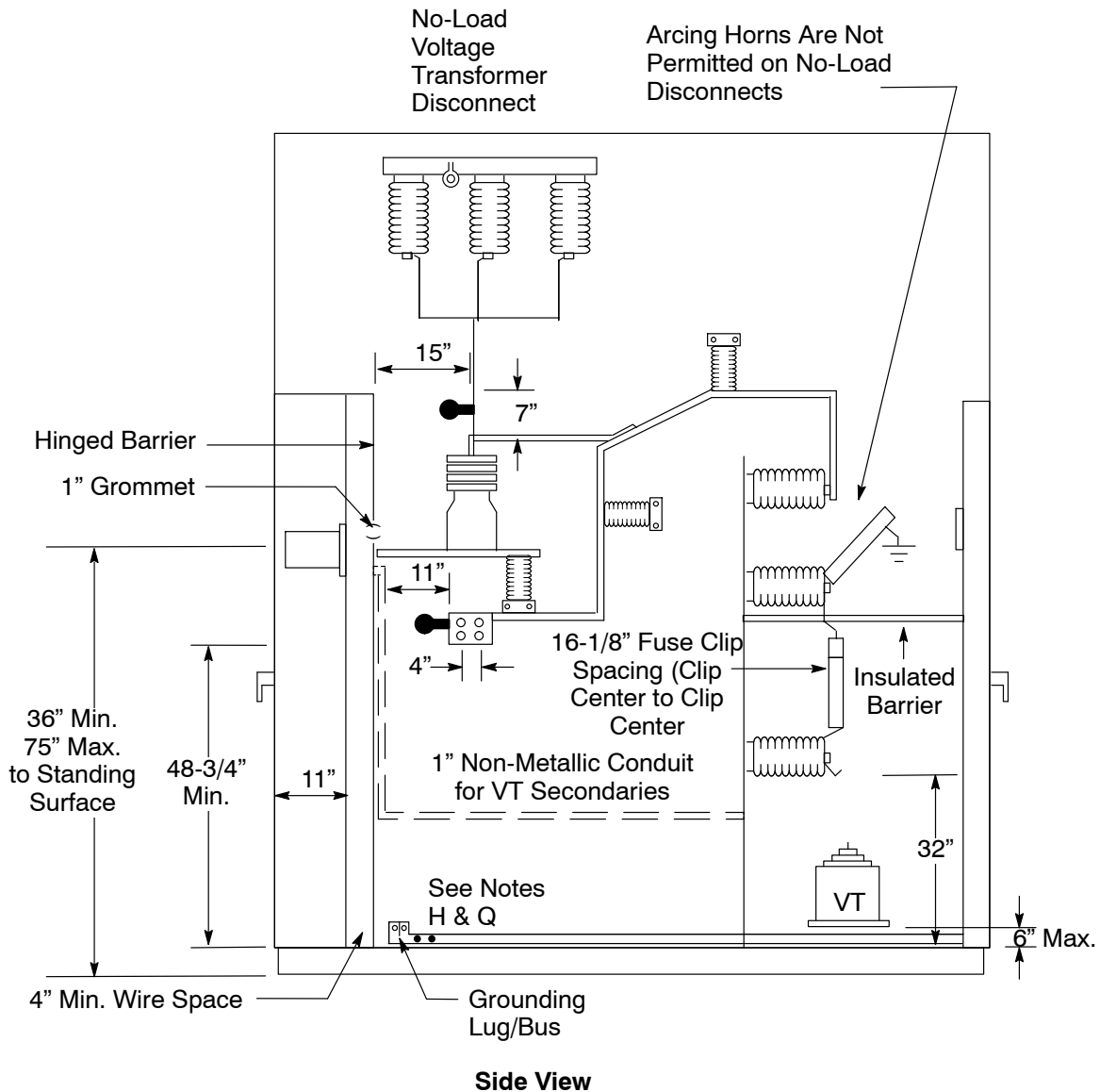

Figure 11-5
Typical, High-Voltage Metering Enclosure, 17,001-Volt Through 25,000-Volt Service

Notes in reference to Figure 11-5 above and Figure 11-6 on Page 11-10.

1. For rear access to the door, refer to the [EUSERC](#) manual, Drawing 400, Sheet 2, Note 7.
2. Connect the primary taps for VTs to the line-side of metering CTs.
3. When switchgear is mounted on rails, include a permanent platform, level with the bottom of the enclosure, in the switchgear installation to provide a clear and level working space in front of the metering compartment.
4. Ensure that the ground bus extends on either the left or right side of the CT compartment's access area. Also, ensure that the grounding terminals are 2 aluminum-bodied mechanical lugs accepting a range of 6 American Wire Gauge (AWG) through 250 thousand circular mils (kcmil) conductors. Finally, ensure that they are identified with a label reading "SAFETY GROUNDING POINT FOR UTILITY USE ONLY."
5. Clearance to any part of the enclosure, including flanges and inner walls.
6. For VT Mounting rail materials and installation details refer to the [EUSERC](#) manual, Drawing 407.

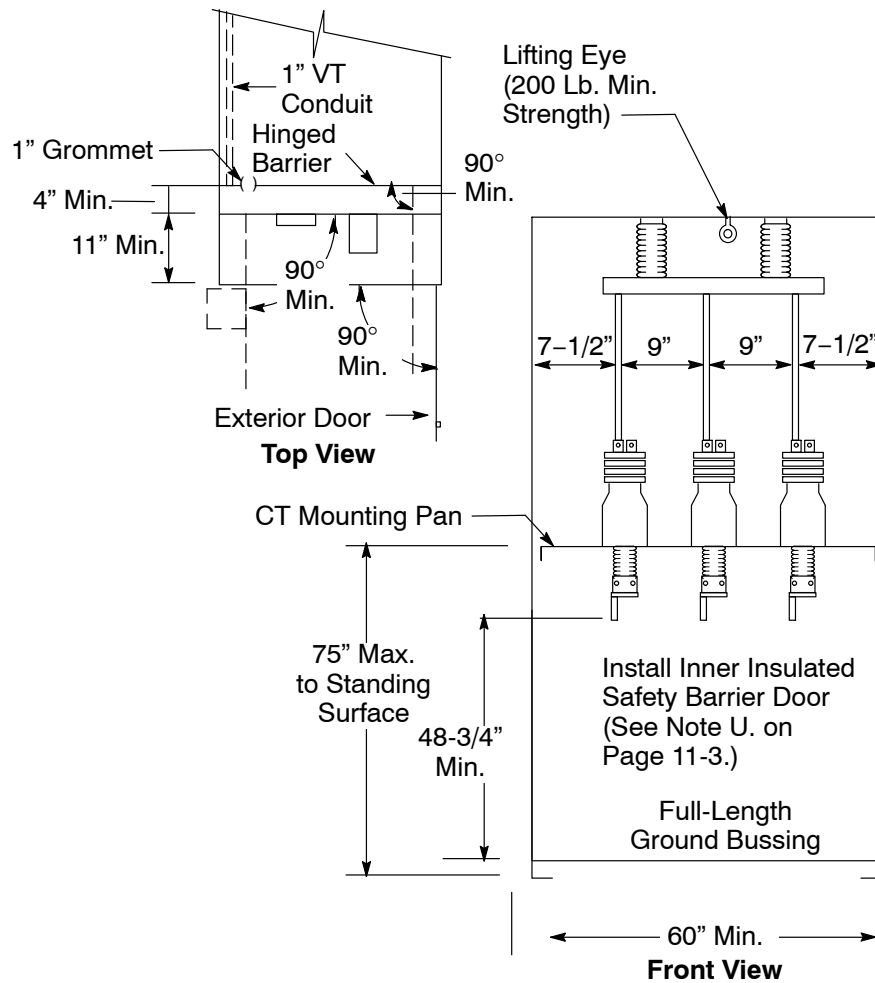

Figure 11-6

Typical, High-Voltage Metering Enclosure, 17,001-Volt Through 25,000-Volt Service

11.4. Interconnection Requirements and Primary Services

When new or existing applicants request services above 600 volts, refer to [PG&E Bulletin TD-2999B-030](#), "Technical Requirements for Electric Service Interconnection at Primary Distribution Voltages," for technical information about primary services. This bulletin is located in [Appendix B](#). If applicants intend to interconnect their generation facilities to PG&E's power system, they must refer to the [PG&E Distribution Interconnection Handbook](#) (<http://www.pge.com/mybusiness/customerservice/nonpgeutility/generateownpower/distributedgeneration/interconnectionhandbook/index.shtml>).

APPENDIX A

ACRONYMS & GLOSSARY

APPENDIX A ACRONYMS & GLOSSARY

Appendix A Acronyms and Glossary

Acronyms

A	ampere, amps
ac	alternating current
AHJ	authority having jurisdiction
AIC	amperes interrupting capacity
ANSI	American National Standards Institute
AWG	American wire gauge
Btu	British thermal unit
CCR	Code of California Regulations
CDF	California Department of Forestry and Fire Protection
CGT	California Gas Transmission
☉	centerline
CPUC	California Public Utilities Commission
CT	current transformer
DA	direct access
DASMMMD	<i>Direct Access Standards for Metering and Meter Data</i>
DASR	direct access service request
dc	direct current
DOT	U.S. Department of Transportation
EFV	excess flow valve
ESP	energy service provider
EUSERC	Electric Utilities Service Equipment Requirements Committee
G.O.	General Order
GRS	galvanized rigid steel
GT&D	Gas Transmission and Distribution
HDPE	high-density polyethylene
Hz	hertz
ID	inside diameter

Acronyms, continued

IMC	intermediate metal conduit
IPS	iron pipe size
k	kilo (1,000)
kcmil	thousand circular mils
K.O.	knock out
kVA	kilovolt ampere
MDMA	meter data management agent
MSP	meter service provider
NEC	National Electric Code
NEM	net energy metering
OH	overhead
OSHA	Occupational Safety and Health Administration
PCC	point of common coupling
psig	pounds per square inch gauge
PRC	California Public Resource Code
PT	potential transformer
PUE	public utility easement
PVC	polyvinyl chloride
scfh	standard cubic feet per hour
SRA	state responsibility areas
TBF	test-bypass facility
TVSS	transient voltage surge suppressor
UG	underground
UL	Underwriters Laboratories
U.S.	United States
USA	Underground Service Alert
V	volts
VT	voltage transformer
W	watt
WC	water column

Glossary

Applicant: This word is used generically throughout the manual to refer to the Pacific Gas and Electric Company (PG&E) customer, or to the person or persons representing the PG&E customer in the application/construction process, including a contractor, design consultant, or installer. The word “customer” will be used only when the word “applicant” is not appropriate. Also, PG&E will sometimes be referred to as the “Company” throughout this manual.

Attachment Structure: A support that connects the service drop to the structure while maintaining the clearances required for the service drop.

Back-Pressure Protection: A check valve between the downstream (i.e., after) section of the meter and the upstream section of the applicant’s piping. This check valve prevents back-flow.

Barricade (Pedestrian Traffic): A suitable barricade to help ensure the safety of pedestrians is a heavy, wire-mesh fencing that is securely supported and is capable of protecting people from the hazards created by the moving parts of stationary machinery.

Barricade (Vehicular Traffic): A suitable barricade for vehicular traffic is concrete-filled steel pipes, 3 inches or greater in diameter, securely set in an adequate concrete pour for support. Also suitable for these conditions is a sleeve-mounted vehicle barricade where the sleeves are set in concrete.

Branch Service Pipe: A pipe that branches off from a gas service pipe to serve two or more applicants.

Conduit System: A system that includes conduits, conduit bends, conduit fittings, and all related components (e.g., bell ends and cable protectors) that are needed to install PG&E cables and conductors.

Cover: The standard distance between the outer surface of an underground facility and the final grade level.

Double Throw Switch: A switch that isolates the applicant’s electrical system from that of the electrical corporation or state or local agency.

Drip Loop: A minimum 18 inches of service-entrance wiring that extends out from the service weatherhead.

Excess Flow Valve (EFV): A device installed in a gas service line at or near the main. An EFV is used to stop the flow of gas if the velocity of the gas passing through the valve creates a pressure difference across the valve that is greater than a specified design limit.

High-Voltage Power Lines: Generally, high-voltage power lines are any overhead lines that connect from pole to pole. These lines typically are 600 volts and greater.

LB: Short-radius conduit fitting. Also known as a service elbow.

Glossary, continued

Low-Growth Zone: Applicants must establish a 15-foot low-growth zone on both sides of all new, electric, high-voltage lines. The zone under the electric power lines should be a low-growth, tree-planting zone and/or a shrub- and flower-planting zone.

Main Service Disconnect: A fusible switch, circuit breaker, or other approved disconnect means for controlling all of (and **only**) the energy registered by that meter. When the governing code or ordinance permits, the disconnect means may consist of a group of fusible or circuit-breaker disconnects.

Mixed-Use Projects: Construction projects that include both commercial and residential loads.

Non-Utility Facilities: Subsurface facilities not owned by any person, corporation, partnership, business, trust, or public agency belonging to a regional, one-call notification system.

Point of Attachment: In areas served from overhead lines, PG&E will install an overhead service drop from the Company's distribution line to a point of attachment on the applicant's residence, building, or structure. The point of attachment may be either on the building wall near the PG&E line or on a periscope fixed to the building's roof, usually not more than 18 inches in back of that wall.

Positive Means: A device that, when used or operated, interrupts or prevents the flow of current to or from the electrical system. Also, a positive means provides the device operator or user with a visual or definite indication of the existing condition or state of the electrical system.

Residential: Class of customers commonly served at either 120/240 volts or 120/208 (network) with amperage ranging from 100 amperes to 320 amperes. Mobile homes installed on foundations also are classified as residential customers.

Secured In Place: The stud will not turn, back out, or loosen in any manner when subjected to normal, UL-approved torques while tightening or loosening terminal nuts. This includes cross-threaded situations.

Service Delivery Point (Electric Supply): The point where PG&E's service drop wires/conductors connect to the applicant's service-entrance conductors for an overhead service. For an underground service, either the point where PG&E's service cables/conductors connect to the applicant's electric meter panel, switchboard, or service termination equipment; or the point where PG&E's service cables/conductors connect directly to applicant's service-entrance conductors.

Glossary, continued

Service Delivery Point (Gas Supply): The point where PG&E's facilities connect to the applicant's house pipe (i.e., houseline). For **residential** and **small commercial** meter sets, the service delivery point is the point where the male threads of the applicant's houseline connect to the female threads of PG&E's gas service tee fitting. Some **commercial** and **industrial** installations do **not** have service tees installed; therefore, the gas supply service delivery point is the first weld or fitting **after** the PG&E-installed bypass valve downstream of (i.e., after) the meter.

Service Elbow: Short-radius conduit fitting. Also known as an LB.

SmartMeter™ Advanced Meter Reading System: A meter using the latest radio frequency technology to transmit meter reads automatically from the gas and electric meters. This allows PG&E's applicants to monitor their daily usage information.

Standard Delivery Pressure: The gas service pressure provided to the service delivery point at 7 inches of water column (WC). This is approximately 1/4 pounds per square inch gauge (psig), as measured at the gas meter outlet.

Switchboard Service Section: The section of an applicant's switchboard provided specifically for terminating the service conductors and for housing the metering transformers (if required), revenue meters, test facilities, and service switch or breaker.

Tariff: A schedule of rates or charges of a business or a public utility.

Test Block: A test block is a specific type of test-bypass **device**. A test block is used for self-contained metering exclusively.

Test-Bypass Facility: Any mechanism used to bypass meter sockets. A test-bypass facility is used for self-contained metering exclusively.

Utility Point of Service (i.e., Service Point): The approved enclosure and the terminated or spliced connections.

Wet-Utility Piping or Facilities: Includes, but is not limited to, water, storm sewer, sanitary sewer, steam, liquid fuels, oil, diesel, sprinkler, irrigation, spigots, downspouts, drain or leach lines, propane, or lines for other liquids or volatile, heavier-than-air gases.

Working Space: An area in front of the meter, the meter enclosure, and the service-conductor termination and pulling facilities. A working space permits access to the equipment and provides a safe working environment for personnel.

This Page Intentionally Left Blank

**APPENDIX B
ELECTRIC AND GAS
SERVICE DOCUMENTS**

APPENDIX B ELECTRIC AND GAS SERVICE DOCUMENTS

Appendix B Electric and Gas Service Documents

Appendix B contains the following documents.

- Tree Planting Matrix Tables
- [TD-7001B-002](#), “PG&E Standards and Requirements for Plug-In Electric Vehicle Interconnections”
- [TD-7001B-005](#), “SmartMeter™ Electric Network Requirements for Indoor Meter Rooms and High-Rise Building Construction”
- [TD-6999B-005](#), “Virtual Net Energy Metering Installations”
- [TD-6999B-048](#), “Requirements for Line Side Interconnections for Distributed Generation”
- [TD-6301B-001](#), “Installing 600 Volt Current Transformers”
- [TD-2424B-002](#), “New Construction Requirements for Installation of Secondary Terminations in Customer Panels Requiring Current Transformer (CT) Installation”
- [Street Light Conduit Detail](#)
- [Flame Resistant \(FR\) Requirement Letter](#)
- [TD-5453B-002](#), “Updated Separation Requirements For Conduit in Joint Trench”
- [Joint Trench Configurations and Occupancy Guide](#)
- [Engineering Material Specification EMS-4123](#), “Backfill Sand”
- [TD-2999B-030](#), “Technical Requirements for Electric Service Interconnection at Primary Distribution Voltages”

Applicants should access Pacific Gas and Electric Company’s (PG&E’s) Internet website at www.pge.com/greenbook to find the latest versions of, and updates to, these documents. Also, applicants may contact their local PG&E service planning office to ensure their documents are current.

NOTE: See [Table FM-1, “Service Planning Office Contact Information.”](#) at the front of this manual starting on Page iv, for specific contact numbers listed by area.

Tree Planting Matrix Tables

Table B-1 through Table B-6 list trees that are suitable for planting near or under power lines. The trees are listed by genus and species in each table. The list is limited and does not include all suitable trees; however, applicants can use this information as a **guideline** for choosing an appropriate tree for planting near power lines. The basic rule of thumb is to choose plants that grow to be 25 feet or less at maturity. For additional suggestions about appropriate trees, consult with nurseries, certified arborists, gardening books, and websites like [SelectTree](http://ecologycenter.org/directory/directory-entries/selectree/) at <http://ecologycenter.org/directory/directory-entries/selectree/> (maintained by the Urban Forest Ecosystems Institute at Cal Poly State University).

PG&E urges applicants to consider planting shrubs, grasses, and flowers near and under power lines. By selecting low-growing vegetation, applicants ensure that trimming back intrusive growth will not be an issue.

Table B-1 Plant Matrix for Stockton, Yosemite, Fresno, and Kern Divisions ¹

Botanical Name Genus and Species	Common Name	Evergreen vs. Deciduous	Height and Spread (in feet)	Drought Tolerant	Special Considerations	Climate Zones ²
<i>Acer buergeranum</i>	Trident Maple	D	25 s	No	Low spreading growth, red to yellow fall color.	4-9, 14-16, 20, 21
<i>Acer palmatum</i>	Japanese Maple	D	25 h	No	Green leaf varieties tolerate sun best, fire resistance favorable.	1-9, 14-24
<i>Cercis canadensis</i>	Eastern Redbud	D	25-40 h ³	No	Small rosy pink flowers in early spring, is easily killed by over-watering.	1-3, 7-20
<i>Cotinus coggygria</i> 'prupurea'	Smoke Tree	D	25 h	—	Branches droop but resist breakage, full sun, dramatic puffs of purple to lavender from fading flowers.	1-24
<i>Crataegus laevigata</i>	English Hawthorn	D	25 h 15 s	—	Thorny branches, need pruning to thin out excess twiggy growth, bright rose to red flowers.	1-11, 14-17
<i>Koelreuteria paniculata</i> 'Kew' or 'Fastigiata'	Golden Rain Tree	D	25 h	No	Branches susceptible to breakage, soil should be well drained, prune to shape.	2-21
<i>Lagerstroemia x faueri</i> cultivars with Indian names	Crape Myrtle(cultivar mentioned w/ Indian names are resistant to powdery mildew)	D	25 h 25 s	Yes	Attracts birds, plant in full sun, various flower colors available, white, red, pink, purple.	7-9, 12-14, 18-21
<i>Laurus saratoga</i>	Saratoga Laurel	E	25 h	—	Compact erect tree, takes pruning well, needs good drainage.	5-9, 12-24
<i>Pittosporum tobira</i>	Tobira	E	15 h	Yes	Small tree. Rarely grows to 30 feet, favorable fire resistance, takes pruning well, full sun or partial shade, clusters of creamy white flowers in spring.	8-24
<i>Prunus cerasifera</i> 'krauter vesuvius' 'thundercloud' and 'newport'	Flowering Plum	E	18 h 12 s	—	Profuse fragrant pink flowers early spring, leaves purple/black, no or little fruit, several cultivars to choose from.	2-22
<i>Syringa reticulata</i>	Japanese Tree Lilac	D	30 h ³	—	Large shrub easily trained as single-stemmed tree, useful as small shade and street tree, showy white flowers in spring.	1-12, 14-16

¹ Plant Matrix for Stockton Division (Amador, Calaveras, San Joaquin, Alpine) (Zones 7, 8, 9, 14), Yosemite Division (Stanislaus, Merced, Tuolumne, Mariposa, Madera) (Zones 1, 7, 8, 9), Fresno Division (Fresno, Kings) (Zones 1, 7, 8, 9) and Kern Division (Kern)(Zones 1, 2, 7, 8, 9).

² Refer to the climate zone map in *Sunset Western Garden Book* for the climate zone in your area.

³ Trees referenced as growing to 30 feet (or more) at maturity generally do not reach their maximum height except under optimum growing conditions.

Table B-2 Plant Matrix for San Francisco, Peninsula, and DeAnza Divisions ¹

Botanical Name Genus and Species	Common Name	Evergreen vs. Deciduous	Height and Spread (in feet)	Drought Tolerant	Special Considerations	Climate Zones ²
<i>Acer griseum</i>	Paperbark Maple	D	25 h	No	Late to leaf out in spring, narrow rounded crown, brilliant red fall color.	1-9, 14-21
<i>Arbutus unedo</i>	Strawberry Tree	E	35 h ³	—	Rarely exceeds 15-20 feet in coastal areas, fire resistance favorable, hanging pink/red flowers, fruit looks similar to strawberries.	4-24
<i>Cercis occidentalis</i>	Western Redbud	D	25 h	Yes	California native, attractive changing flower and foliage color, is easily killed by over-watering.	2-24
<i>Crateagus lavallei</i>	Carriere Hawthorn	D	25 h 15-20 s	—	Dark green leaves, turn bronze red after sharp frost, white flowers in spring, red and orange fruit can be messy on walkways.	1-11, 14-17
<i>Eriobotrya deflexa</i> 'coppertone'	Bronze Loquat	E	25 h 25 s	No	Shrubby, easily trained to a tree, new growth is copper for long time before turning green.	8-24
<i>Garrya elliptica</i>	Coast Silktassel	E	25 h	Yes	California native, fire resistance favorable graceful yellowish/green catkins 3-inches to 8-inches long on males.	5-9, 14-21
<i>Koelreuteria paniculata</i> 'Kew' or 'Fastigiata'	Golden Rain Tree	D	25 h	No	Branches susceptible to breakage, soil should be well drained, prune to shape.	2-21
<i>Leptospermum laevigatum</i>	Australian Tea Tree	E	30 h ³ 30 s	Yes	Grows best near the coast, flowers in spring, needs full sun, it is quite frost sensitive.	14-24
<i>Rhus lancea</i>	African Sumac	E	25 h 20 s	Yes	Slow growing, takes high summer heat. Can be multi-stemmed or trained to one stem tree. Good screen.	8, 9, 12-24
<i>Prunus cerasifera</i> 'krauter vesuvius' 'thundercloud' and 'newport'	Flowering Plum	E	18 h 12 s	—	Profuse fragrant pink flowers early spring, leaves purple/black, no or little fruit, several cultivars to choose from.	2-22
<i>Prunus serrulata</i> 'Kwanzan'	Flowering Cherry	D	25 h	—	Spectacular spring flowers, needs moist protected site, good soil drainage and full sun.	2-7, 14-20

¹ Plant Matrix for San Francisco Division (San Francisco) (Zone 17), Peninsula Division (San Mateo) (Zones 14, 15, 16, 17) and De Anza Division (Santa Clara) (Zones 15, 16, 17).

² Refer to the climate zone map in *Sunset Western Garden Book* for the climate zone in your area.

³ Trees referenced as growing to 30 feet (or more) at maturity generally do not reach their maximum height except under optimum growing conditions.

Table B-3 Plant Matrix for San Jose, Central Coast, and Los Padres Divisions ¹

Botanical Name Genus and Species	Common Name	Evergreen vs. Deciduous	Height and Spread (in feet)	Drought Tolerant	Special Considerations	Climate Zones ²
<i>Acer griseum</i>	Paperbark Maple	D	25 h	No	Late to leaf out in spring, narrow rounded crown, brilliant red fall color.	1-9, 14-21
<i>Crateagus phaenopyrum</i>	Washington Thorn	D	25 h 20 s	—	Orange red fall foliage, shiny red fruit, light open limb structure, least susceptible to fireblight.	1-11, 14-17
<i>Eriobotrya deflexa</i> 'coppertone'	Bronze Loquat	E	25 h	No	Shrubby, easily trained to a tree, new growth is copper for long time before turning green.	8-24
<i>Laurus saratoga</i>	Saratoga Laurel	E	25 h	—	Compact erect tree, takes pruning well, needs good drainage.	5-9, 12-24
<i>Ligustrum ovalifolium</i>	California Privet	semi- deciduous	15 h	—	Inexpensive hedge plant, takes pruning well.	4-24
<i>Malus floribunda</i> 'adams', 'robinson'	Crabapple	D	25 h 30 s	—	Attracts birds and bees, good disease resistance, <i>several cultivars to choose from.</i>	1-11, 14-21
<i>Myoporum insulare</i>	Myoporum	E	30 h ³ 20 s	—	Fire resistant, takes full sun, it is quite frost sensitive.	8, 9, 15-17, 19-24
<i>Myrica californica</i>	Pacific Wax-myrtle	E	25 h	Yes	California native, fire resistance favorable.	4, 5, 6, 14-17, 20-24
<i>Olea europaea</i> 'Swan Hill'	Fruitless Olive	E	30 h ³ 25 s	—	Does well in areas with hot dry summers, full sun, withstands heavy pruning.	8, 9, 11-24
<i>Pittosporum tobira</i>	Tobira	E	25 h	Yes	Small tree. Rarely grows to 30 feet, favorable fire resistance, takes pruning well, full sun or partial shade, clusters of creamy white flowers in spring.	8-17, 19-24
<i>Prunus cerasifera</i> 'krauter vesuvius' 'thundercloud' and 'newport'	Flowering Plum	E	18 h 12 s	—	Profuse fragrant pink flowers early spring, leaves purple/black, no or little fruit, <i>several cultivars to choose from.</i>	2-22
<i>Tristania laurina</i> 'Elegans'	Elegant Brisbane Box	E	25 h	No	Can be trained to be a single or multi-stemmed trunk, excellent for screen and boundary planting.	15-18, 19-24

¹ Plant Matrix for San Jose Division (Santa Clara) (Zones 15, 16, 17), Central Cost Division (Santa Cruz, San Benito, Monterey) (Zones 7, 14, 15, 16, 17) and Los Padres Division (San Luis Obispo, Santa Barbara) (Zones 2, 3, 7, 14, 15, 16, 17, 18, 23, 24).

² Refer to the climate zone map in *Sunset Western Garden Book* for the climate zone in your area.

³ Trees referenced as growing to 30 feet (or more) at maturity generally do not reach their maximum height except under optimum growing conditions.

Table B-4 Plant Matrix for North Valley, Sierra, and Sacramento Divisions ¹

Botanical Name Genus and Species	Common Name	Evergreen vs. Deciduous	Height and Spread (in feet)	Drought Tolerant	Special Considerations	Climate Zones ²
<i>Acer ginnala</i>	Amur Maple	D	25 h	No	Multi-trunk large shrub or trained at nursery as one stem tree, striking red fall color.	1-9, 14-16
<i>Acer palmatum</i>	Japanese Maple	D	25 h	No	Green leaf varieties tolerate sun best, fire resistance favorable.	1-9, 14-24
<i>Cercocarpus ledifolius</i>	Curly Leaf Mountain Mahogany	E	20 h	Yes	Native to dry mountain slopes, attractive open branching pattern, OK in full sun.	1-3, 7-14, 18, 19
<i>Cornus kousa</i>	Kousa Dogwood	D	25 h	No	Needs ample water, big multi-stem shrub can be trained to a tree, white flowers.	3-9, 14, 15, 18, 19
<i>Crateagus phaenopyrum</i>	Washington Thorn	D	25 h 20 s	—	Orange red fall foliage, shiny red fruit, light open limb structure, least susceptible to fireblight.	1-11, 14-17
<i>Garrya elliptica</i>	Coast Silktassel	E	25 h	Yes	California native, fire resistance favorable, graceful yellowish/green catkins 3-inches to 8-inches long on males.	5-9, 14-21
<i>Lagerstroemia x fauerei</i> cultivars with Indian names	Crape Myrtle (<i>cultivar mentioned w/ Indian names are resistant to powdery mildew</i>)	D	25 h 25 s	Yes	Attracts birds, plant in full sun, various flower colors available, white, red, pink, purple.	7-9, 12-14, 18-21
<i>Laurus saratoga</i>	Saratoga Laurel	E	25 h	—	Compact erect tree, takes pruning well, needs good drainage.	5-9, 12-24
<i>Sorbus aucuparia</i>	European Mountain Ash	E	30 h ³ 20 s	—	Stands winter cold, strong winds, low humidity and extreme heat, attractive to birds, bright fruit, clustered white flowers.	1-10, 14-17
<i>Styrax japonica</i>	Japanese Snowdrop Tree, Japanese Snowbell	D	30 h ³	No	Needs well drained soil, full sun or part shade, plenty of water. Prune to control shape, tends to be shrubby if lower branches left.	3-10, 14-21
<i>Syringa reticulata</i>	Japanese Tree Lilac	D	30 h ³	—	Large shrub easily trained as single-stemmed tree, useful as small shade and street tree, white showy flowers in spring.	1-12, 14-16

¹ Plant Matrix for North Valley Division (Shasta, Tehama, Glenn, Butte) (Zones 1, 7, 8, 9), Sierra Division (Sutter, Yuba, Nevada, Sierra, Placer, El Dorado) (Zones 1, 7, 8, 9) and Sacramento Division (Yolo, Colusa, Solano) (Zones 7, 8, 9, 14).

² Refer to the climate zone map in *Sunset Western Garden Book* for the climate zone in your area.

³ Trees referenced as growing to 30 feet (or more) at maturity generally do not reach their maximum height except under optimum growing conditions.

Table B-5 Plant Matrix for Diablo, Mission, and East Bay Divisions ¹

Botanical Name Genus and Species	Common Name	Evergreen vs. Deciduous	Height and Spread (in feet)	Drought Tolerant	Special Considerations	Climate Zones ²
<i>Aesculus californica</i>	California Buckeye	D	25 h needs room, very wide spreading	Yes	California native, grows best in cool, coastal foothills.	4-7, 14-19
<i>Acer truncatum</i>	"Truncatum" Maple	D	20 h	No	Adaptable tree, leaves are purplish red, summer green, dark purple in autumn.	1-9, 14-23
<i>Cercis canadensis</i>	Eastern Redbud	D	25-35 h ³	No	Small rosy pink flowers in early spring, is easily killed by over-watering.	1-3, 7-20
<i>Crateagus phaenopyrum</i>	Washington Thorn	D	25 h 20 s	—	Orange red fall foliage, shiny red fruit, light open limb structure, least susceptible to fireblight.	1-11, 14-17
<i>Laurus saratoga</i>	Saratoga Laurel	E	25 h	—	Compact erect tree, takes pruning well, needs good drainage.	5-9, 12-24
<i>Ligustrum ovalifolium</i>	California Privet	semi- deciduous	15 h	—	Inexpensive hedge plant, takes pruning well.	4-24
<i>Magnolia stellata</i>	Star Magnolia	D	10 h 20 s	No	Profuse bloom in late winter, early spring.	1-9, 14-24
<i>Malus floribunda</i> 'adams', 'robinson'	Crabapple	D	25 h 30 s	—	Attracts birds and bees, good disease resistance, <i>several cultivars to choose from.</i>	1-11, 14-21
<i>Prunus cerasifera</i> 'krauter vesuvius' 'thundercloud' and 'newport'	Flowering Plum	E	18 h 12 s	—	Profuse fragrant pink flowers early spring, leaves purple/black, no or little fruit, <i>several cultivars to choose from.</i>	2-22
<i>Prunus serrulata</i> 'Kwanzan'	Flowering Cherry	D	25 h	—	Spectacular spring flowers, needs moist protected site, good soil drainage and full sun.	2-7, 14-20
<i>Styrax japonica</i>	Japanese Snowdrop Tree, Japanese Snowbell	D	30 h ³	No	Needs well-drained soil, full sun or part shade, plenty of water, prune to control shape, tends to be shrubby if lower branches left.	3-10, 14-21

¹ Plant Matrix for Diablo Division (Alameda, Contra Costa) (Zones 15, 16, 17), Mission Division (Alameda) (Zones, 7, 14, 15) and East Bay Division (Contra Costa) (Zones 7, 14, 15, 16, 17).

² Refer to the climate zone map in *Sunset Western Garden Book* for the climate zone in your area.

³ Trees referenced as growing to 30 feet (or more) at maturity generally do not reach their maximum height except under optimum growing conditions.

Table B-6 Plant Matrix for North Coast and North Bay Divisions ¹

Botanical Name Genus and Species	Common Name	Evergreen vs. Deciduous	Height and Spread (in feet)	Drought Tolerant	Special Considerations	Climate Zones ²
<i>Acer truncatum</i>	“Truncatum” Maple	D	20 h	No	Adaptable tree, leaves are purplish red, summer green, dark purple in autumn.	1-9, 14-23
<i>Aesculus californica</i>	California Buckeye	D	25 h needs room, very wide spreading	Yes	California native, grows best in cool, coastal foothills.	4-7, 14-19
<i>Amelanchier alnifolia</i>	Mountain Serviceberry	D	20 h	—	Suited to mountainous parts of the west, attractive foliage changes color.	1-6, 15, 16, 17
<i>Callistemon citrinus</i>	Lemon Bottlebrush	E	25 h	Yes	Favorable fire resistance, attracts hummingbirds, shrub easily trained to a tree, it is quite frost sensitive.	8, 9, 12-24
<i>Cercis occidentalis</i>	Western Redbud	D	25 h	Yes	California native, attractive changing flower and foliage color, is easily killed by over watering.	2-24
<i>Cotinus coggygria</i> <i>'prupurea'</i>	Smoke Tree	D	25 h	—	Branches droop but resist breakage, full sun, dramatic puffs of purple to lavender from fading flowers.	1-24
<i>Crataegus laevigata</i>	English Hawthorn	D	25 h 15 s	—	Thorny branches, need pruning to thin out excess twiggy growth, bright rose to red flowers.	1-11, 14-17
<i>Eriobotrya deflexa</i> <i>'coppertone'</i>	Bronze Loquat	E	25 h	No	Shrubby, easily trained to a tree, new growth is copper for long time before turning green.	8-24
<i>Leptospermum laevigatum</i>	Australian Tea Tree	E	30 h ³ 30 s	Yes	Grows best near the coast, flowers in spring, needs full sun, it is quite frost sensitive.	14-24
<i>Myoporum insulare</i>	Myoporum	E	30 h ³ 20 s	—	Fire resistant, takes full sun, tough, fast growing, it is quite frost sensitive.	8, 9, 15-17, 19-24
<i>Styrax japonica</i>	Japanese Snowdrop Tree, Japanese Snowbell	D	30 h ³	No	Needs well-drained soil, full sun or part shade, plenty of water, prune to control shape, tends to be shrubby if lower branches left.	3-10, 14-21

¹ Plant Matrix for North Coast (counties Humboldt, Mendocino, Lake, Sonoma) (Zones 1, 2, 14, 15, 17) and North Bay Division (counties Napa, Marin) (Zones 7, 14, 15, 16, 17).

² Refer to the climate zone map in *Sunset Western Garden Book* for the climate zone in your area.

³ Trees referenced as growing to 30 feet (or more) at maturity generally do not reach their maximum height except under optimum growing conditions.

PG&E-Prohibited Trees

Applicants must **not** plant the trees listed in Table B-7, “Do Not Plant These Trees Under or Within 15 Feet of Overhead Power Lines,” under or within 15 feet of overhead power lines. When mature, these trees affect PG&E’s ability to provide and maintain safe and reliable service. Many species of trees are **not** appropriate for confined spaces under electric lines, although they may be appropriate for other locations within a development or building site. The list is limited and does not include all varieties of unsuitable trees; however, applicants can use this information as a **guideline** when choosing an appropriate tree for planting near power lines. Applicants should plant trees that grow higher than 25 feet at maturity **at least 15 feet to the side of overhead power lines.**

Under the botanical names of the trees, occasionally only the genus is listed. Applicants should not plant **any** types of trees within these genera under or within 15 feet of overhead power lines.

Table B-7 Do Not Plant These Trees Under or Within 15 Feet of Overhead Power Lines

Botanical Name (Genus and species)	Common Name	Evergreen vs Deciduous	Height and Spread (in feet)	Special Considerations	Climate Zones ¹
<i>Acacia baileyana</i>	Bailey Acacia	—	30 h	Most commonly planted. Fast growing, short lived.	7-9, 13-24
<i>Acacia mellanoxylon</i>	Blackwood Acacia	—	40 h 20 s	Fast dense upright growth. Roots aggressive, lifts sidewalks, splits easily and suckers (grows from the roots).	8, 9, 13-24
<i>Acer macrophyllum</i>	Bigleaf Maple	D	30-95 h	Native to California foothills, too big for small gardens and streets.	4-17
<i>Acer negundo</i>	Box Elder	D	60 h	Fast growing, seeds readily, subject to breakage.	1-10, 12-24
<i>Acer rubrum</i>	Red Maple	D	40+ h 20+ s	Fast growing, red twigs, branchlets and buds.	1-9, 14-17
<i>Acer saccharinum</i>	Silver Maple	D	40-100 h equal spread	Fast growth, weak wood.	1-9, 12, 14-24
<i>Ailanthus altissima</i>	Tree of Heaven	D	50 h	Fast growing, suckers and self seeds.	All zones
<i>Alnus spp.</i>	Alder Trees	D	40-90 h	Relatively fast growing, invasive roots, several native California species.	Various
<i>Eucalyptus</i>	Eucalyptus	E	30-200 h	Fast growing, invasive roots, many species.	8-24
<i>Fraxinus</i>	Ash Trees	D	35-80 h	Relatively fast growing.	
<i>Carya illinoensis</i>	Pecan Trees	D	70 h 70 s	Long tap root and leathery mature leaves.	8-9, 12-14, 18-20
<i>Catalpa spp.</i>	Catalpa	D	up to 70 h	Some litter from fallen flowers in summer and seed capsules in fall. Seldom develops dominate shoot without shaping.	All zones
<i>Juglans spp.</i>	Walnut Trees	D	30-100 h spreading	Various species, check <i>Sunset Western Garden Book</i> , English and Black Walnut notorious for hosting aphids, honeydew is inevitable.	Various
<i>Liriodendron tulipifera</i>	Tulip Tree	D	up to 80 h 40 s	Fast growing, straight columnar trunk. Spreading root system makes it hard to garden under.	1-12, 14-23
<i>Liquidambar styraciflua</i>	Sweetgum, Liquidambar	D	60 h 25 s	Moderate growth rate, upright, somewhat cone shaped, fruits are spiny balls that need raking in fall. Roots can be a nuisance in lawns or parking strips.	1-12, 14-24
<i>Metasequoia glyptostroboides</i>	Dawn Redwood	D	up to 90 h	Salt winds and hot sunlight cause foliage burn.	3-9, 14-24
<i>Phoenix Canariensis</i>	Canary Island Date Palm	Palm/E	60 h 50 s	Grows slowly until it forms trunk, then speeds up a little. Slow to develop new head after hard frost.	9, 12- 24

¹ Refer to the climate zone map in *Sunset Western Garden Book* for the climate zone in your area.

Table B-7 Do Not Plant These Trees Under or Within 15 Feet of Overhead Power Lines, continued

Botanical Name (Genus and species)	Common Name	Evergreen vs. Deciduous	Height and Spread (in feet)	Special Considerations	Climate Zones ¹
<i>Pinus spp.</i>	Pine Trees	D	30-100 h wide spreading	Some faster growing than other species. Many varieties.	various
<i>Platanus acerifolia.</i>	London Plane, Sycamore	D	40-80 h 30-40 s	Fast growing. Subject to anthracnose (causing early continuous leaf fall)	2-24
<i>Populus nigra italica</i>	Lombardy Poplar	D	40-100 h	Fast growing, invasive roots systems, suckers profusely.	All Zones
<i>Populus trichocarpa</i>	Black Cottonwood	D	150-180 h wide spreading	Heavy limbed, wood is very brittle. Native along mountain streams and wet lowlands west of cascades, California to Alaska.	1-7
<i>Pseudotsuga Menziesii</i>	Douglas Fir	E	70-250 h	Can't be maintained at a reduced height without butchering the tree. Native to Northwest America as far south as Fresno County.	1-10, 14-17
<i>Quercus lobata</i>	Valley Oak	D	70 h up to 70 s	Native to California. Limbs often twisted, long drooping outer branches can sweep ground.	1-3,6-16, 18-21
<i>Quercus spp.</i>	Oak Trees	D	up to 80 h 70 s	Various species, check Sunset Western Garden Book.	Various
<i>Robinia pseudoacacia</i>	Black Locust	D	75 h	Fast growth. Wood is brittle, roots aggressive, plants of spread by suckers.	All zones
<i>Salix babylonica</i>	Weeping Willow	D	50 h 50 s	Fast growing. Invasive root systems and are difficult to garden under.	All zones
<i>Sequoia sempervirens</i>	Coast Redwood	E	90 h 30 s	World's tallest tree! Optimum conditions to 350f. Fast growing. Can defeat lawns.	4-9, 14-24
<i>Ulmus spp.</i>	Elm Trees	D	100 h 70 s	Various species, check <i>Sunset Western Garden Book</i> . Root systems are aggressive. Branch crotches often narrow, easily split, Attracts leaf beetles, bark beetles, leafhoppers, aphids and scale. Care can be messy.	Various
<i>Washingtonia filifera</i>	California Fan Palm	Palm/ E	60 h	Fast growing, native to California.	8,9,11-24
<i>Washingtonia robusta</i>	Mexican Fan Palm	Palm/E	100 h	Very fast growing.	8,9,11-24
<i>Zelkova serrata</i>	Sawleaf Zelkova	D	60+ h 60 s	Moderate to fast growth.	3-21

¹ Refer to the climate zone map in *Sunset Western Garden Book* for the climate zone in your area.

This Page Intentionally Left Blank



PG&E Standards and Requirements for Plug-In Electric Vehicle Interconnections

Summary This bulletin describes the requirements for the various metering and connection options to serve Plug-in Electric Vehicles (PEV) and Electric Vehicle Supply Equipment (EVSE). These requirements apply only to residential customers. Please refer to the 2010 *Electric and Gas Service Requirements* ([Greenbook](#)) for additional service and metering information.

Affected Document 2010 *Greenbook*.

Target Audience PG&E residential customers connecting Plug-In Electric Vehicles. PG&E employees who perform customer contact or electric meter field work.

What you need to know

Plug-In Electric Vehicle (PEV) Interconnection

PG&E Standards and Requirements

General Requirements:

Basic illustrations are provided to show the options that an existing PG&E residential customer has to connect and meter plug-in Electric Vehicle Supply Equipment (EVSE). Local or state officials may stipulate additional provisions for installation of the EVSE system. All customer electric service and meter installations must be reviewed and approved by Pacific Gas and Electric Company. For questions regarding PG&E's PEV requirements, please contact the [New Construction Service Center](#) (NCSC) at 877-743-7782.



PG&E Standards and Requirements for Plug-In Electric Vehicle Interconnections

Specific Requirements:

1. Customers must notify PG&E of the additional electrical load before connecting a PEV. The increased load may require the electric service cables, conduit, and meter panel to be upgraded. See note (1) below.
2. All installations must be approved by PG&E and the local (city/county) inspection agency or the authority having jurisdiction.
3. The E-9A [Time-of-Use](#) (TOU) rate is optional for residential PEV customers who elect to remain with a single meter. See note (2) below.
4. The E-9B TOU rate is mandatory for residential PEV customers who elect to meter their PEV usage separately. See note (2) below.
5. This bulletin does not apply to commercial, industrial, and agricultural customers. They are served under existing PG&E rates and rules.
6. E-9B Rate signage for multi-meter panel: PG&E will permanently attach signage to the front of the panel and next to the dedicated electric vehicle meter stating, "Dedicated to PEV charging equipment only; other loads must not be connected."
7. E-9B Rate signage for two meters, one on each panel: PG&E will permanently attach signage to the front of each meter panel as follows:
 - a. On the main panel stating, "Caution: This premise has a second meter for PEV charging equipment."
 - b. On the second panel stating, "Dedicated to PEV charging equipment only; other loads must not be connected."
8. Dual meter socket adapters are not approved for use.
9. A customer owned generation system (e.g. solar, wind) is allowed to be connected to the E-9B meter panel. The energy generated cannot serve both (E-9B and house) meters. Customers that want to supply generation energy to both meters will need to add a separate generation system and request a second Net Energy Metering (NEM) account. See note (5) below.

Note:

- (1) Refer to PG&E's [Electric Rule 16](#) for service upgrade information.
- (2) Refer to PG&E's [Electric Rate Schedules](#) for current information.
- (3) Refer to the 2010 *Electric and Gas Service Requirements* ([Greenbook](#)) for additional information.
- (4) Information for new business customers is on the [New Construction Service Center](#) (NCSC) website.
- (5) PG&E's Generation Interconnection Services (GIS) may be reached at gen@pge.com or leave a message on their hotline: 415-972-5676.

PG&E Standards and Requirements for Plug-In Electric Vehicle Interconnections

Residential: E-9A Time Of Use (TOU) rate - Optional
Single-Meter Panel option for House and Electric Vehicle Load.

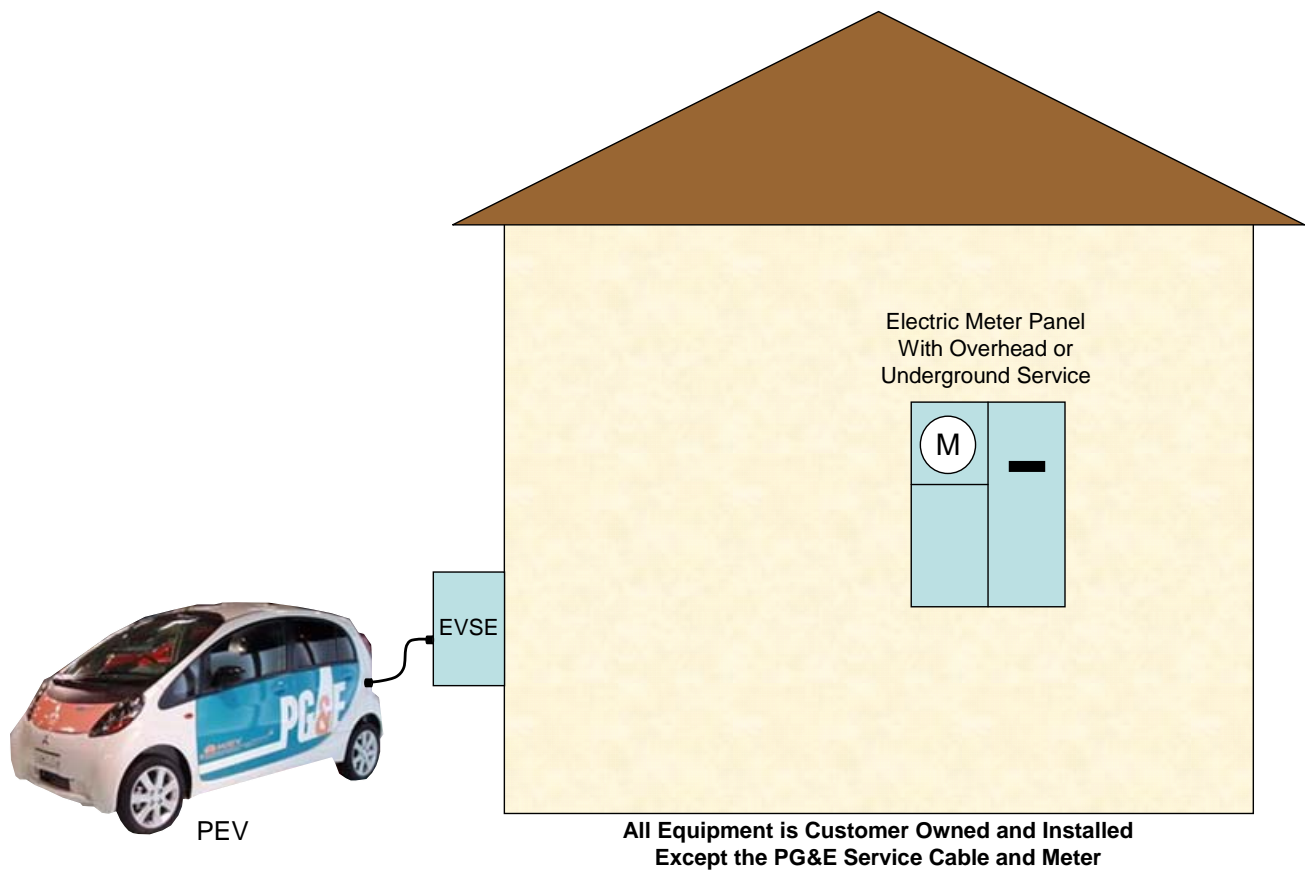

Pros:

- No second meter panel installation
- Low off peak TOU rate

Cons:

- Easier to exceed lower tiered baselines
- Panel upgrade may be required due to added EV load
- High peak TOU rate

PG&E Standards and Requirements for Plug-In Electric Vehicle Interconnections

Residential: E-9B Time Of Use (TOU) rate
 Multi-Meter Panel option for House and Electric Vehicle Load.

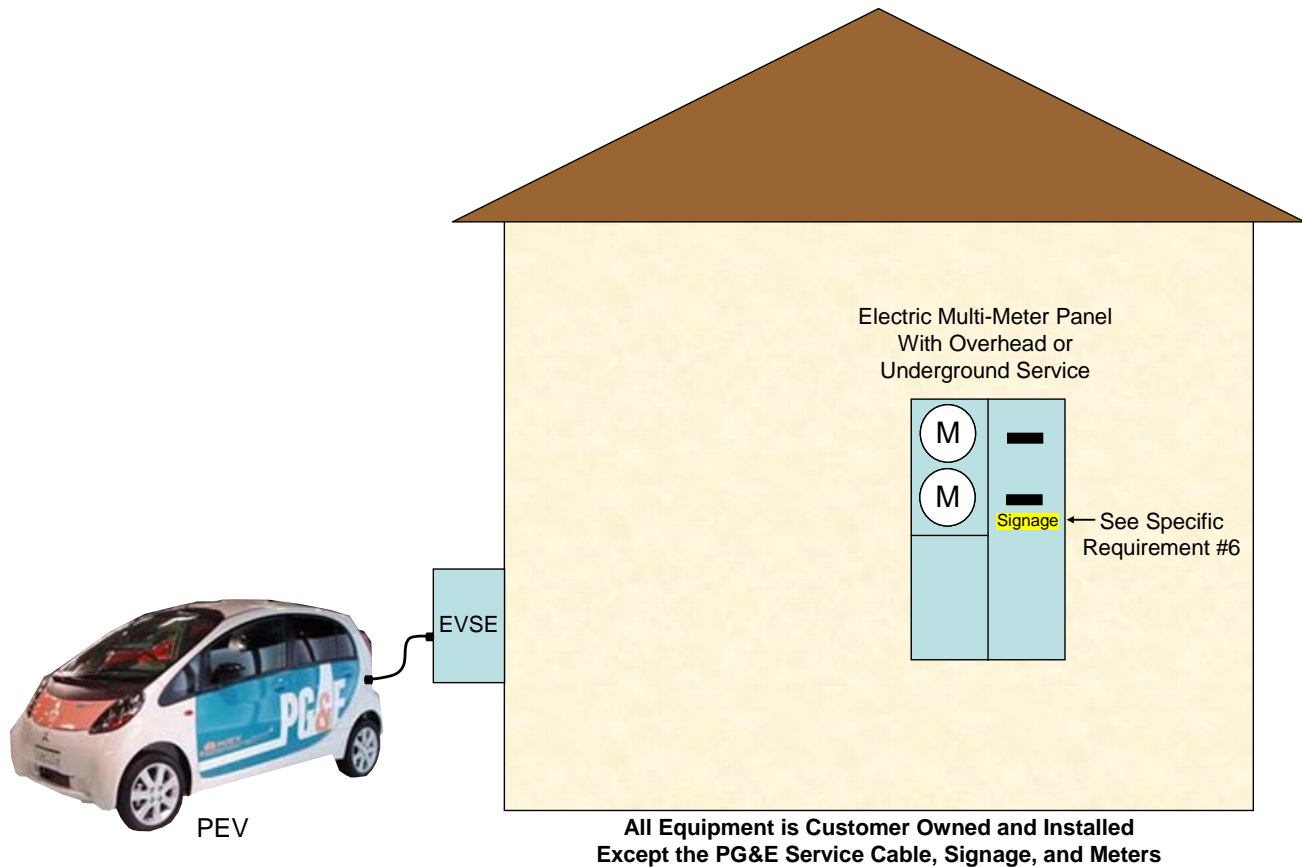

Pros:

- Maintain existing rate schedule for house load
- Separate baseline allotment for EV load

Cons:

- Additional expense for multi-meter panel installation
- Service upgrade may be required due to added EV load

PG&E Standards and Requirements for Plug-In Electric Vehicle Interconnections

Residential: E-9B Time Of Use (TOU) rate
 Second-Meter Panel Option Connected to Existing Meter Panel; Overhead Service

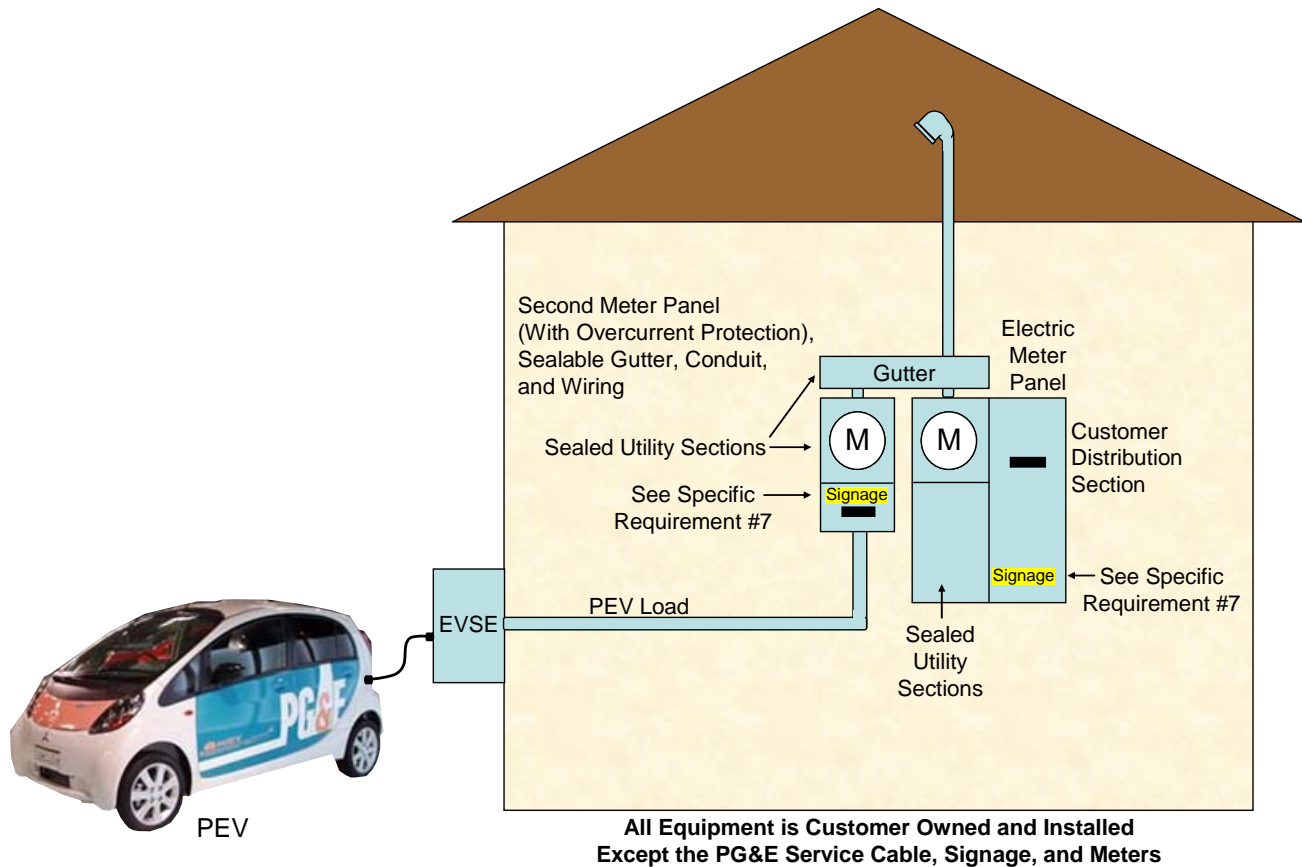

Pros:

- Existing panel upgrade may not be required
- Maintain existing rate schedule for house load
- Separate baseline allotment for EV load

Cons:

- Additional expense to accommodate second-meter panel installation
- Not allowed by all local (city/county) inspection agencies or the authority having jurisdiction

PG&E Standards and Requirements for Plug-In Electric Vehicle Interconnections

Residential: E-9B Time Of Use (TOU) rate

Second-Meter Panel Option Connected to Existing Meter Panel; Underground Service

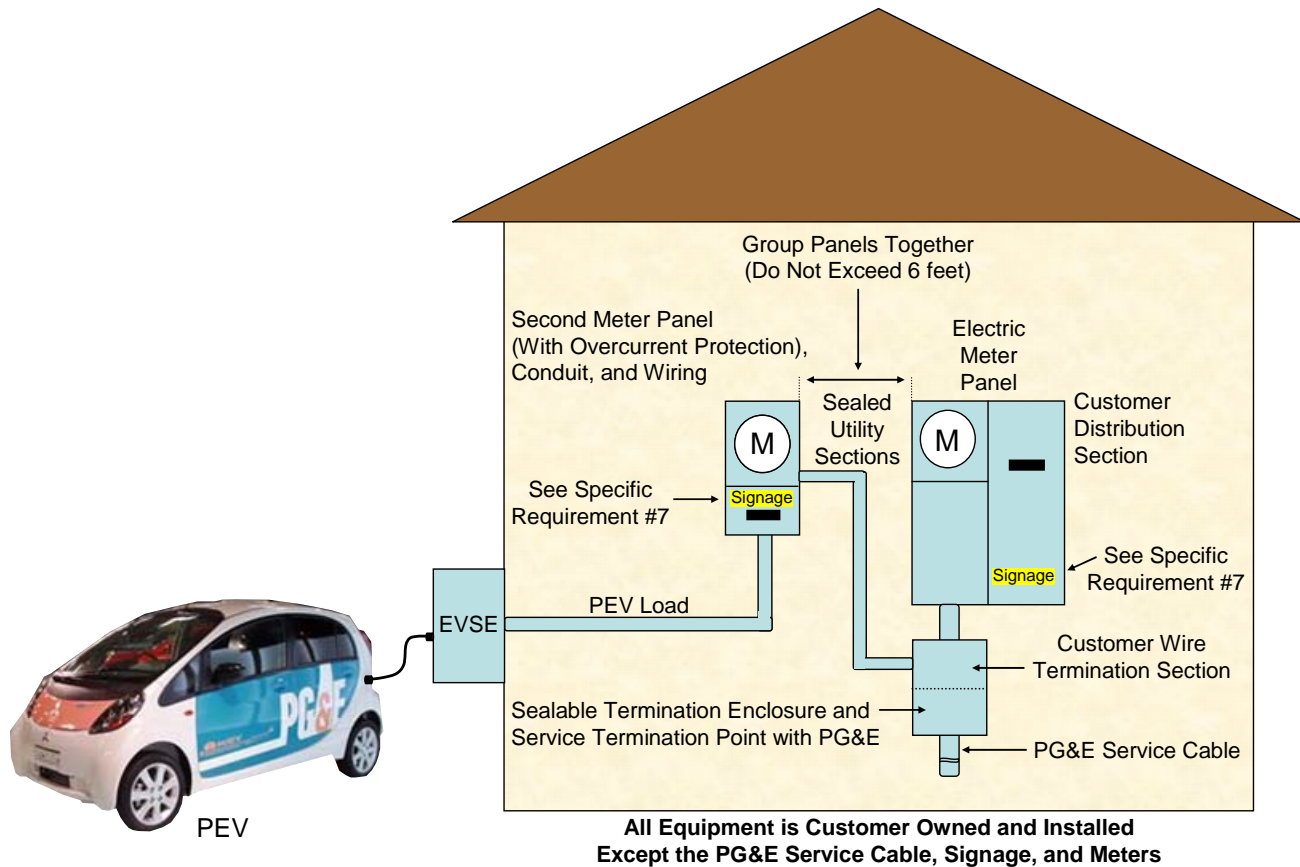

Pros:

- Existing panel upgrade may not be required
- Maintain existing rate schedule for house load
- Separate baseline allotment for EV load

Cons:

- Additional expense to accommodate second-meter panel installation
- Service upgrade may be required due to added EV load
- Not allowed by all local (city/county) inspection agencies or the authority having jurisdiction



PG&E Standards and Requirements for Plug-In Electric Vehicle Interconnections

Approved By Roozbeh (Rudy) Movafagh - Manager, Electric Distribution Standards and Strategy

Document Contact Daniel Jantz – Senior Distribution Specialist, 8-223-6664, 415-973-6664

Inclusion Plan This bulletin will be Incorporated into Appendix B of the 2011 *Greenbook*.



SmartMeter[™] Electric Network Requirements for Indoor Meter Rooms and High-Rise Building Construction

Summary

This Bulletin provides SmartMeter[™] infrastructure installation and construction requirements for customers designing indoor electric meter rooms and high-rise buildings. This will address below-grade and multiple above-grade meter room situations such as those that may exist in an urban, high-rise environment to ensure PG&E's SmartMeter[™] mesh network is established for these customers. These provisions are required for commercial and/or residential, single or multiple, indoor meter rooms to ensure SmartMeter[™] electric network communication access and performance.

Affected Document

Electric and Gas Service Requirements ([Greenbook](#)), specifically [Section 5.2](#)

Target Audience

All PG&E customers including contractors, developers, builders, architects, electricians, and plumbers. PG&E employees including electric metering, inspectors, SmartMeter[™] Operations Center (SM OC), and service planning.

What you need to know

To make sure customers' SmartMeters[™] are connected to the SmartMeter[™] mesh network, provisions must be made for access to mount equipment and pathways for radio frequency communications. It is important to make the necessary provisions for SmartMeter[™] equipment early in the planning stage for high-rise or below-grade meter room situations to prevent additional costs from being incurred by customers and/or by PG&E. Special provisions to facilitate the installation of SmartMeter[™] technology meters and equipment include:

- Access by PG&E personnel for placement of radio frequency equipment
- Path for radio frequency (RF) signal propagation (i.e., conduit)
- Placement of ancillary RF equipment (in-room relay or access point)
- Conduit and cable routing. Placement and mounting of antennas (MPACK or Salt-shaker antennas)

Please review the drawings on pages 3 through 7 which illustrate these required provisions. The minimum requirements in this bulletin should not preclude applicable building, fire, or electrical code requirements.

Because many of the buildings and situations where these provisions will be required are custom in nature, design plans must be submitted to your local service planner for review by the local meter shop supervisor and any other appropriate department. Communicating early in the design process will allow for additional site-specific review by the SM OC Tier 4 Analyst(s).



SmartMeter^(TM) Electric Network Requirements for Indoor Meter Rooms and High-Rise Building Construction

Requirements for Details A, B, and C:

Conduit Size: 3-inch in diameter. The 3-inch conduit is not required to be installed in the floor for meter rooms at grade level. Only in the ceiling.

Conduit Type: Non-metallic Schedule 40 or better.

Conduit Caps: Non-metallic permanent caps, of the same conduit type and size, must be placed on both ends of the conduit. The cap ends should be flush with the ceiling or floor surface.

Firestop System: Install as required by local building, fire, or electrical code.

Conduit Placement: Inside the meter room. Preferably in front of the meter panel. The conduit must not be blocked by any equipment or objects.

Requirements for Details C, D, and E:

Firestop System: Not required. Do not install.

Conduit Size: 2-inch in diameter.

Conduit Type: Conduits installed, in walls, ceilings, floors, or concrete must be made of rigid steel. For all other locations the conduit type can be electrical metallic tubing (EMT) or better.

Conduit Cap: A temporary cap, of the same type and size as the conduit, must be placed on the end of the conduit next to the meter panel.

Conduit Termination Inside: The conduit must be terminated in a horizontal position on top of the meter panel section and 6 to 12 inches from the front of it. The conduit must **not** enter or pass through the switchgear or enclosure.

Conduit Termination Outside: The conduit must terminate in a horizontal position, inside a termination enclosure, on the outside building wall. The conduit must be 8 to 10 feet above grade level and protrude 1-inch outward from the wall.

Termination Enclosure: A minimum 6" x 6" x 6", NEMA 3R rated, with an accessible front cover. It must be permanently installed to the outside wall with the conduit terminated inside.

Conduit Bends: Any bend must have a minimum 12-inch radius.

Junction box: A minimum size of 12" x 12" x 4" is required for pulling when the total number of degrees of conduit bends exceeds 270 between end points or junction boxes. A junction box is also required when the conduit run length exceeds 100 feet. The total length of all conduits must not exceed 475 feet.

Pulling Tape: Rated for a minimum of 500 lbs and placed inside the conduit for its entire length from end to end to facilitate cable pulling.

Transformer Rooms: Conduit must **not** be installed inside of a transformer room. Conduits can be installed in the floors, ceilings, or walls of the room.

Working Space: The open area that must be maintained around all

SmartMeterTM Electric Network Requirements for Indoor Meter Rooms and High-Rise Building Construction

switchboards, metering enclosures, and the outdoor conduit.

- 1 Above the entire top of switchboard or enclosure a minimum of 12 inches of vertical clearance.
- 2 In front of the switchboard a minimum of 48 inches of horizontal clearance and extending to a height 12" above the switchboard or enclosure.
- 3 In front of the location where the outdoor conduit terminates a minimum area of 36 inches deep, as measured from the outside building wall, by 30 inches wide and extending upward to 12 inches above the conduit.

Figure 1 - High Rise Building with Indoor Electric Meter Rooms

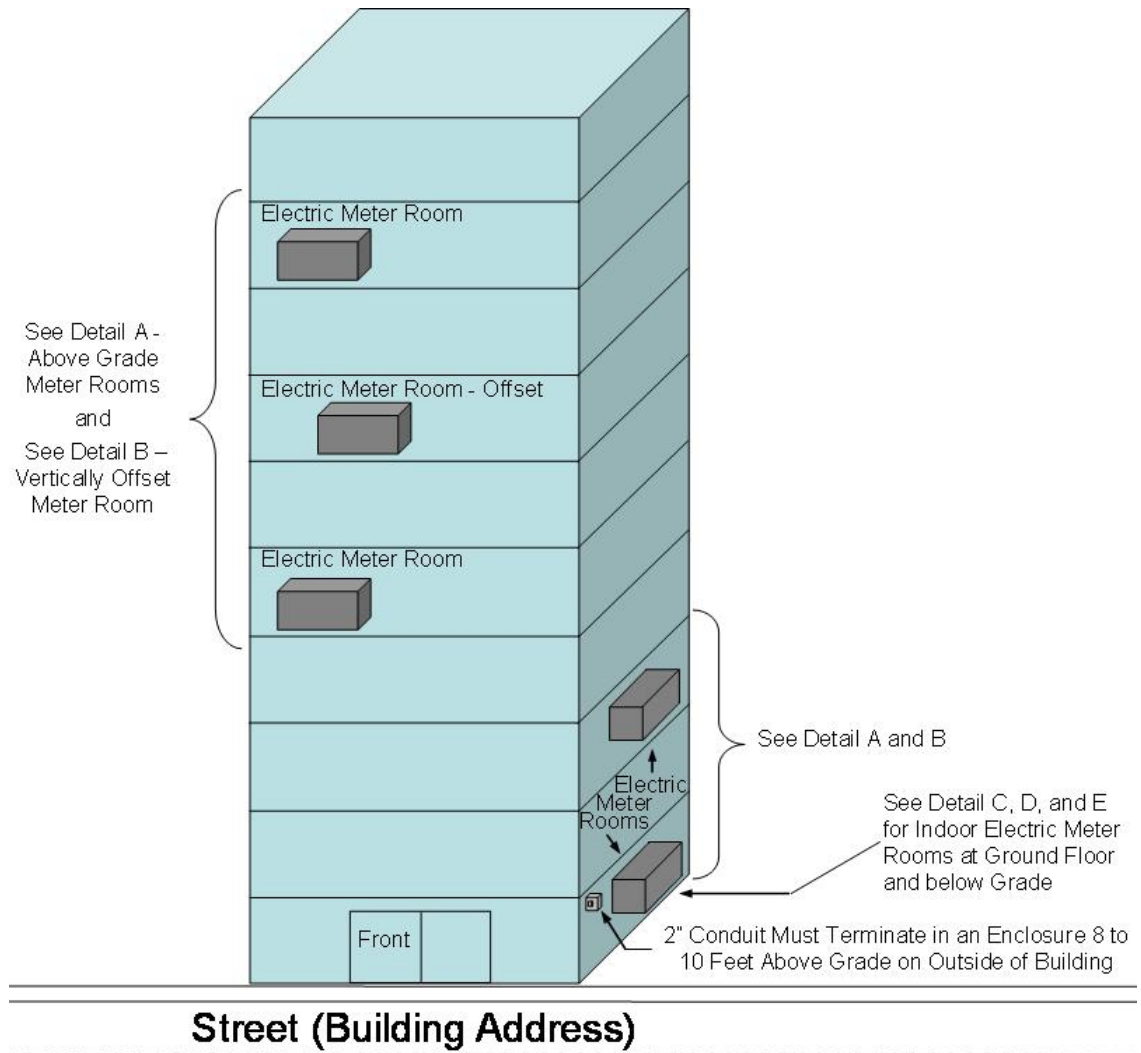



SmartMeter^(TM) Electric Network Requirements for Indoor Meter Rooms and High-Rise Building Construction

Figure 2 - Detail A: Above Grade Meter Rooms

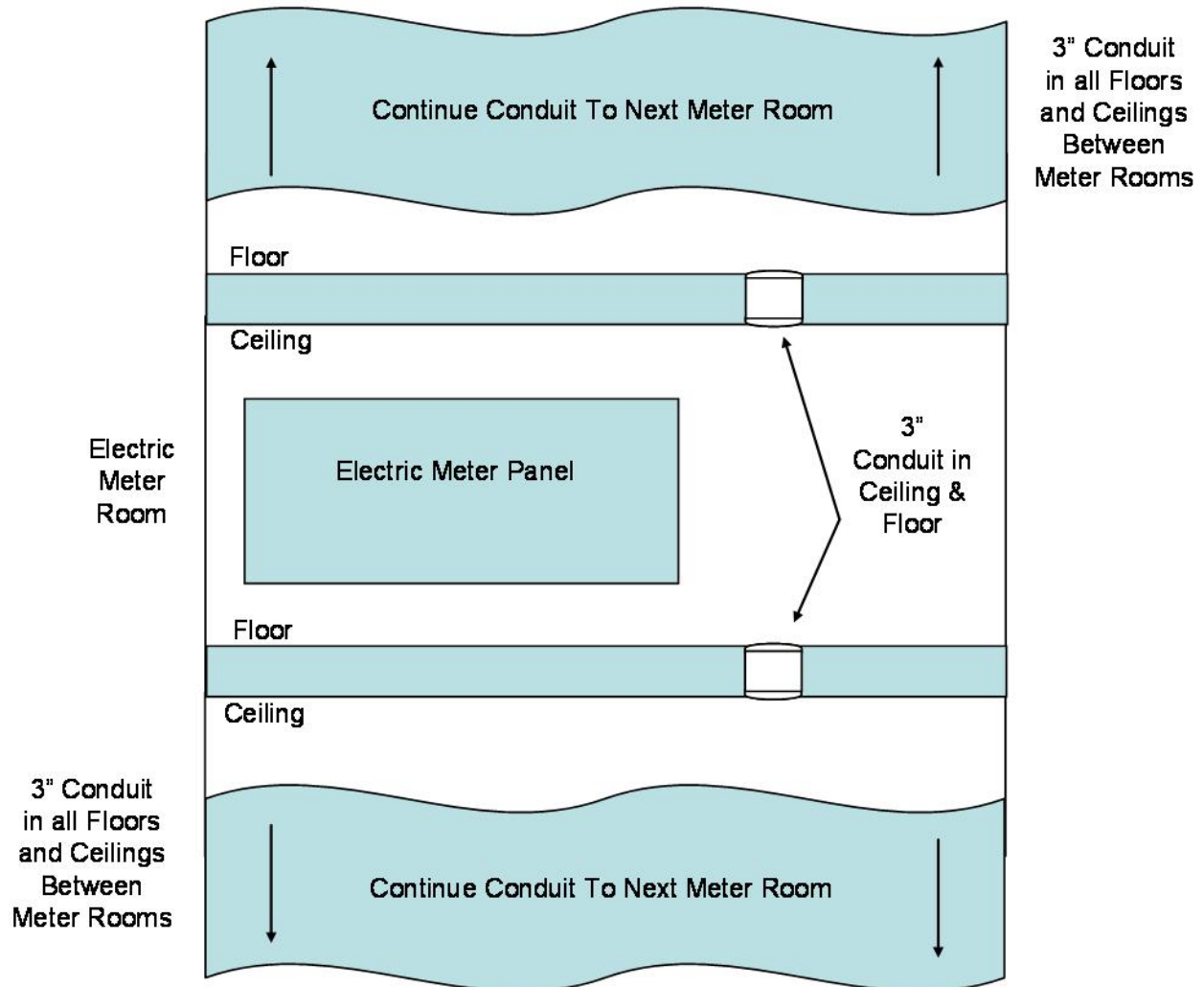

SmartMeter™ Electric Network Requirements for Indoor Meter Rooms and High-Rise Building Construction

Figure 3 - Detail B: Vertically Offset Meter Rooms

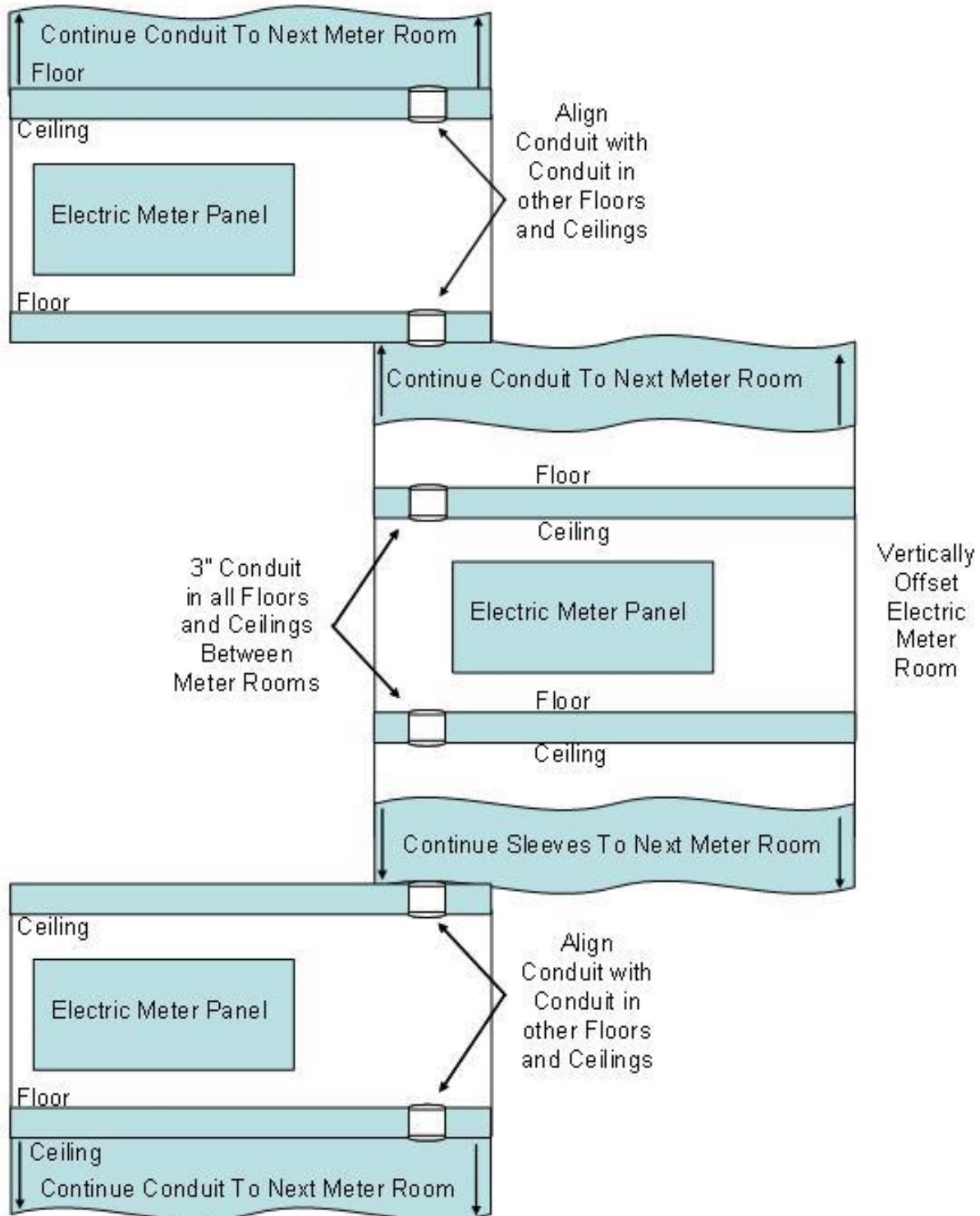



SmartMeter™ Electric Network Requirements for Indoor Meter Rooms and High-Rise Building Construction

Figure 4 - Detail C – Indoor Electric Meter Room at Ground Floor

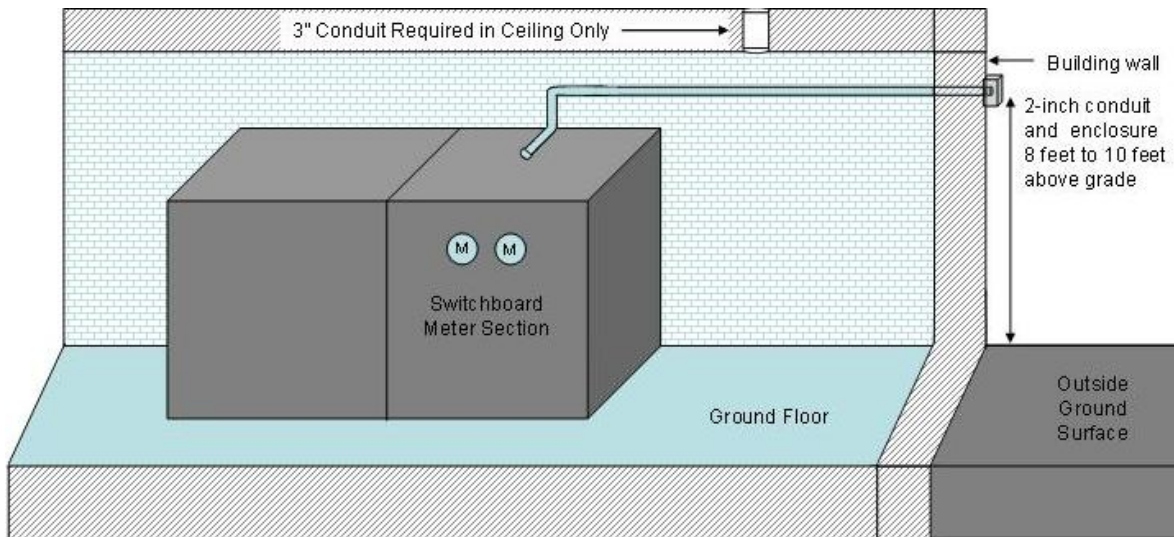
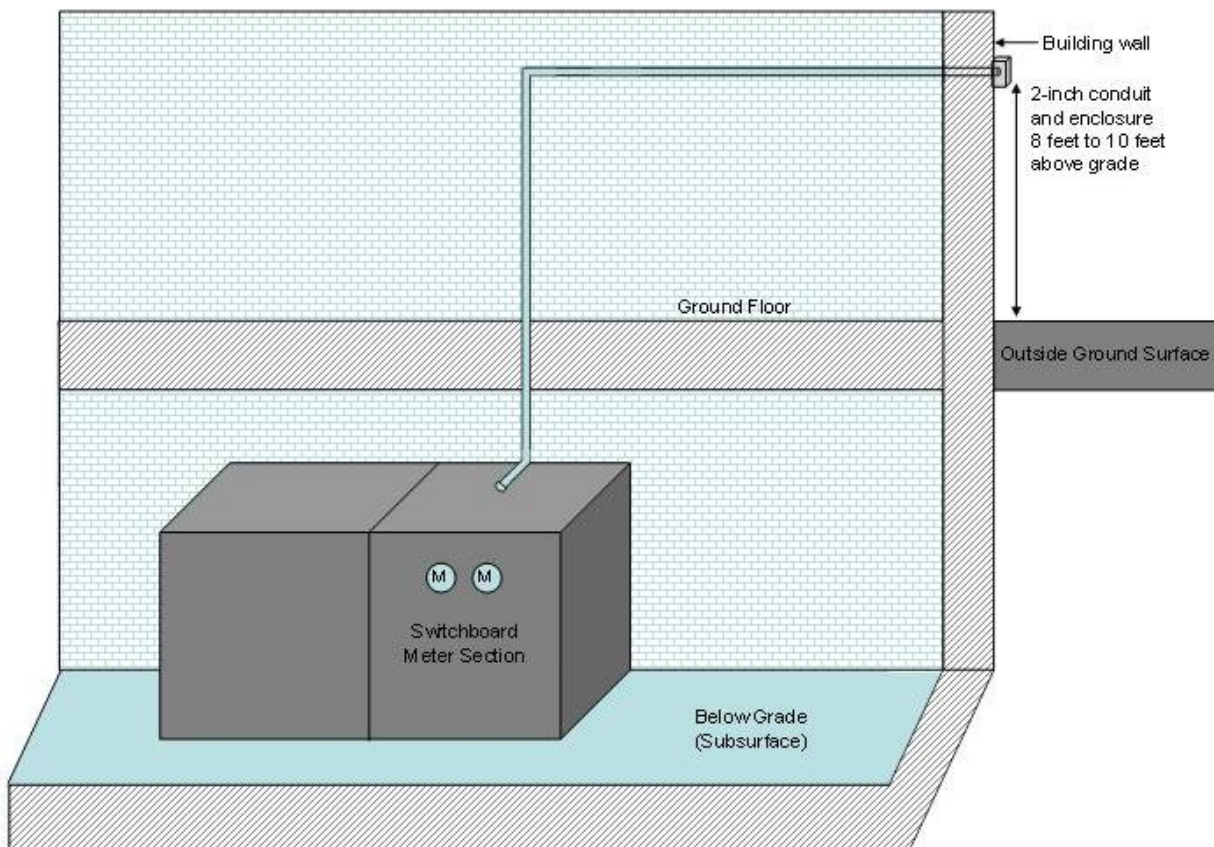

Figure 5 - Detail D – Indoor Electric Meter Room Below Grade (Subsurface)





SmartMeter™ Electric Network Requirements for Indoor Meter Rooms and High-Rise Building Construction

Figure 6 - Detail E – Multiple Electric Meter Rooms at or Below Ground Floor

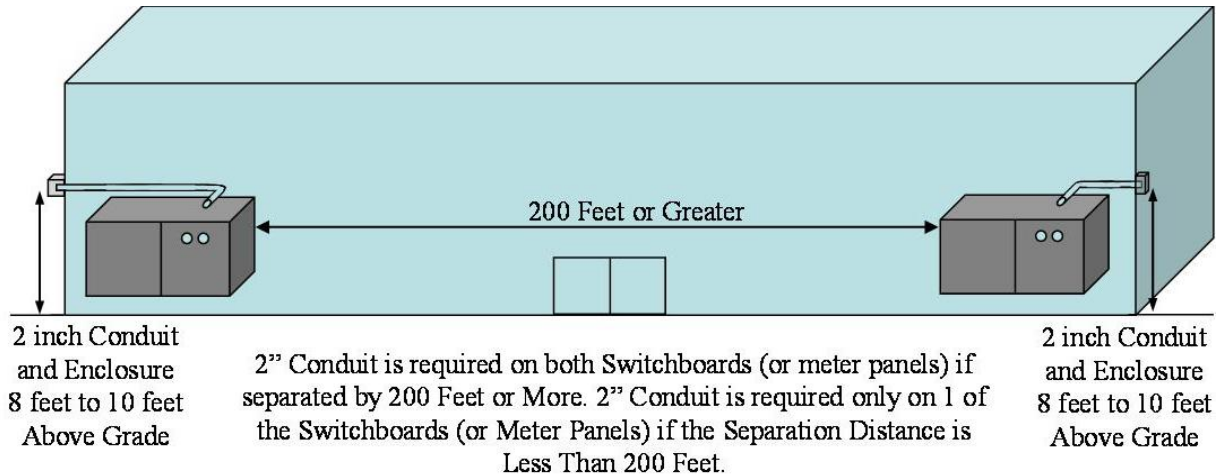

Approved By

James L Meadows, Director, Smart Meter Project

Document Contact

Eric Schoenman, Senior IT Operations Analyst, SmartMeter™ Operations Center

Daniel Jantz, Senior Distribution Specialist, 8-223-6664, 415-973-6664

Inclusion Plan

This Bulletin will reside on PG&E's Technical Information Library and will be in effect until cancelled or incorporated by another document.

The information in this Bulletin will be included into the *Electric and Gas Service Requirements (Greenbook) Manual* and the *Electric Meter Work Practices Manual*.

Virtual Net Energy Metering Installations

SUMMARY

This bulletin describes requirements for metering and interconnecting customer generation for all Virtual Net Energy Metering (NEMV) programs. NEMV installations will require a generation output meter (NGOM) that only measures the generation produced and must not be tied into any of the individual residential or common use meters at the premise. The totalized amount of generation registered on the NGOM will be shared, through the PG&E billing process, by all residents at the site.

Level of Use: Informational Use

AFFECTED DOCUMENT

None

TARGET AUDIENCE

PG&E customers that qualify under the NEMV program and PG&E employees who perform customer contact and electric meter field work.

WHAT YOU NEED TO KNOW

General Requirements

1. Developers must contact PG&E's Electric Generation Interconnection (EGI) department and submitting all applicable documents for approval **before** starting any installations.
2. Submit single line and elevation drawings and detailed pictures, to EGI, showing the point of interconnection. The NEMV point of interconnection will require prior review and approval from all appropriate PG&E departments **before** any connections can be made.
3. All installations and equipment must be approved by PG&E and approved by the local (city/county) inspection agency or the Authority Having Jurisdiction (AHJ) before any NGOM meter is set by PG&E.
4. For any NEMV installation that requires a service disconnect/reconnect, developers must coordinate with the EGI department to request for a local PG&E inspector and metering department to inspect and approve all line side connections before reconnecting the service.
5. Developers must install UL approved service equipment with provisions for making solar interconnections that are **not** in any PG&E sealed sections and ahead of all tenant / house meters.

Virtual Net Energy Metering Installations

Specific Requirements

1. Applicants will provide, own, and install all equipment except for the PG&E NGOM and metering equipment (i.e. current transformers, test switch).
2. NGOM panels must have test bypass facilities and meet the requirements in Section 7 of the latest Greenbook. NGOM panels greater than 200 A must meet Greenbook requirements in Section 9 and 10.
3. Meter height, working space and gas clearances must be met as specified in Section 5.4. of the Greenbook.
4. Applicants will pull and connect generation conductors into the panel. Generation conductors in the panel must be clearly labeled "NGOM PV" at the point of interconnection for PG&E field personnel to identify.
5. NGOM meter panels must have the generation connected to the **LOAD** side of the NGOM socket and the utility grid on the **LINE** side of the socket.
6. Point of connection
 - a. Underground Service Multi-meter Panels:
 - Inside the main switch section, as shown in Figure 1 with approval from the local AHJ, or
 - Install a sealable wiring gutter, as shown in Figure 2

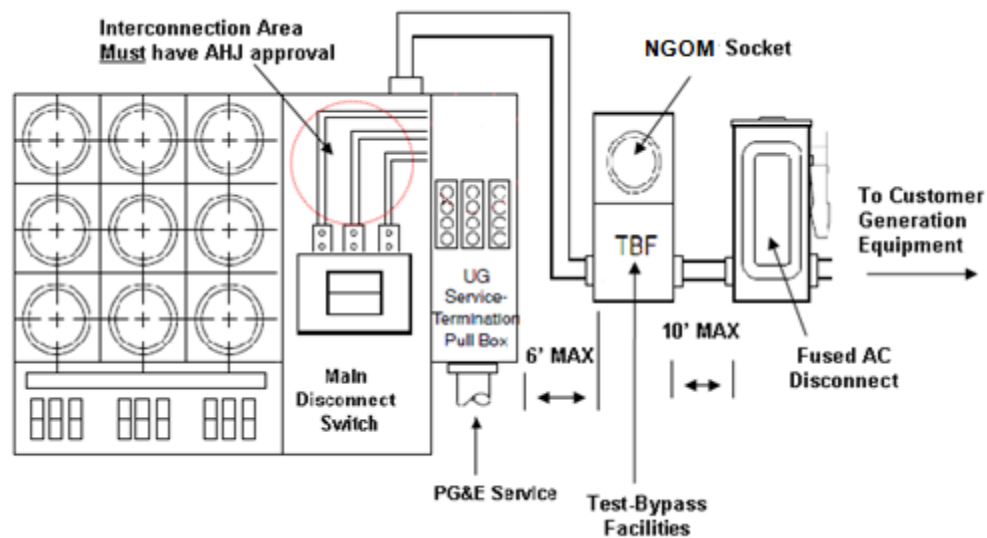

Figure 1: Point of Connection inside Main Switch for Underground Service

Virtual Net Energy Metering Installations

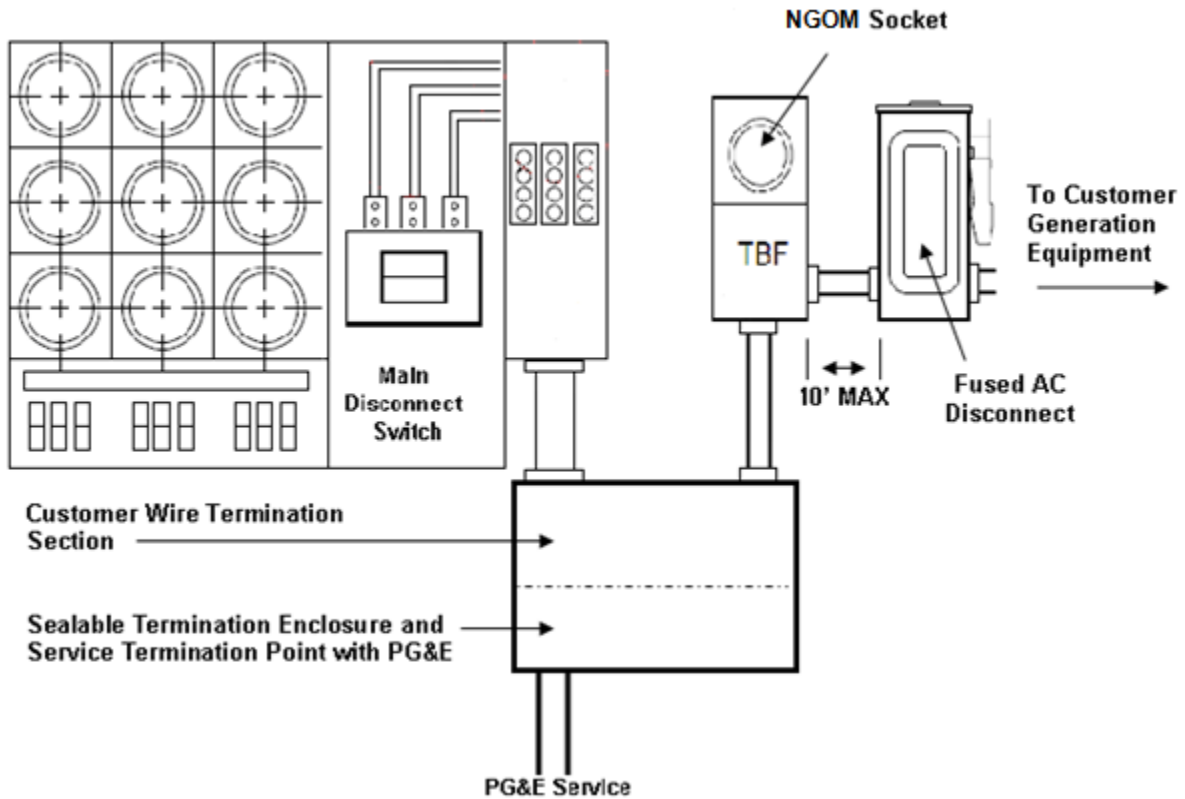

Figure 2: Point of Connection with Termination Enclosure for Underground Service

b. Overhead Service Multi-meter Panels:

- Inside the main switch section, as shown in Figure 3 with approval from the local AHJ, or
- Install a sealable wiring gutter, as shown in Figure 4

Virtual Net Energy Metering Installations

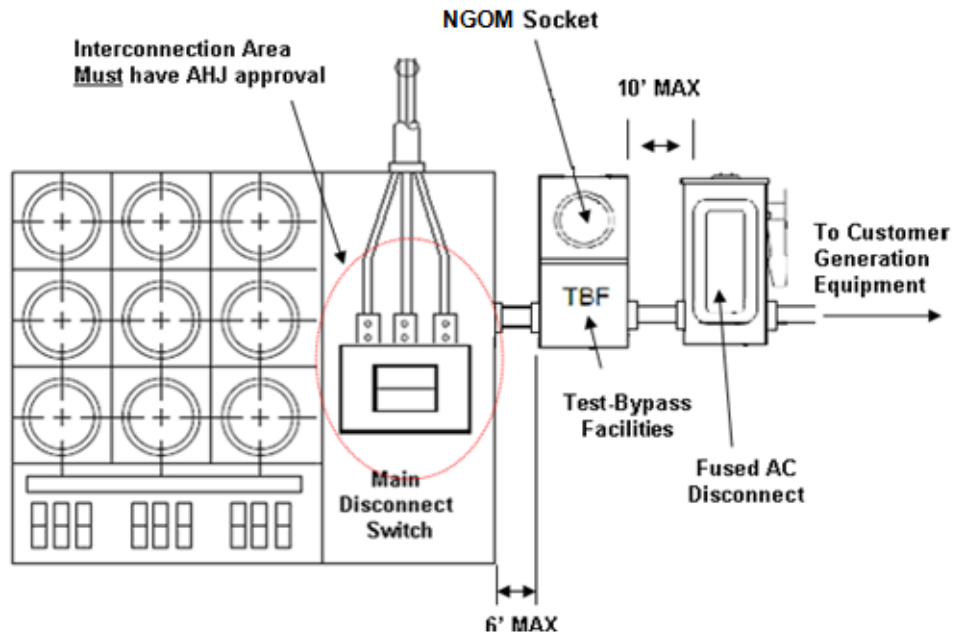

Figure 3: Point of Connection for Overhead Service

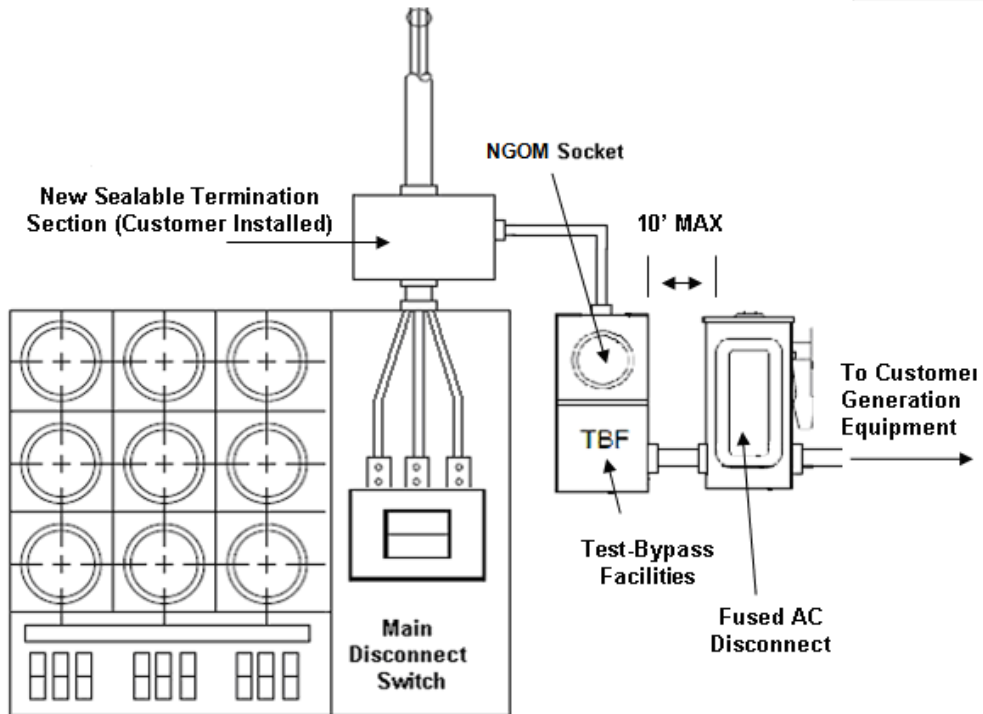

Figure 4: Point of Connection for Overhead Service

Virtual Net Energy Metering Installations

c. Multi-Meter Switchboards

- Single metered switchboards with the service termination below the metering section cannot be used for any NEMV programs.
- Because of various types of configurations and arrangements of switchboard compartments, the items below **must** be satisfied in order to interconnect into an existing switchboard. All other switchboard configurations will be denied interconnection.
 - (1) The service termination is a separate section from the utility metering CT section.
 - (2) The customer has an overhead service where PGE's service conductors end at the weather head, see Figure 5.

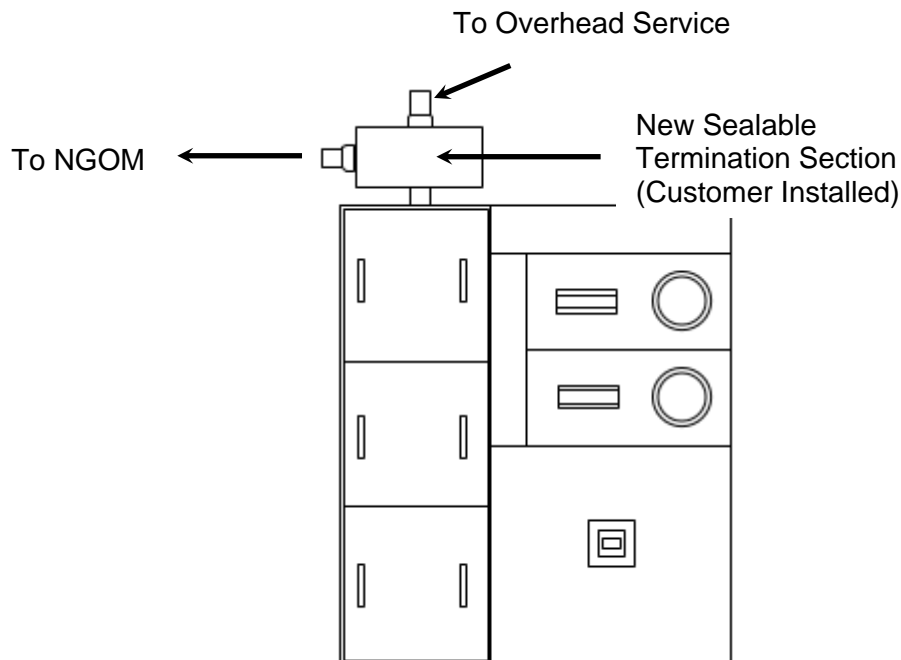

Figure 5: Point of Connection for Overhead Service Switchboard

- (3) The service termination section is bus duct.

Virtual Net Energy Metering Installations

- (4) The service termination must have clear separation from utility service conductors and customer owned conductors to the CT section. See Figures 6, 7 and 8.

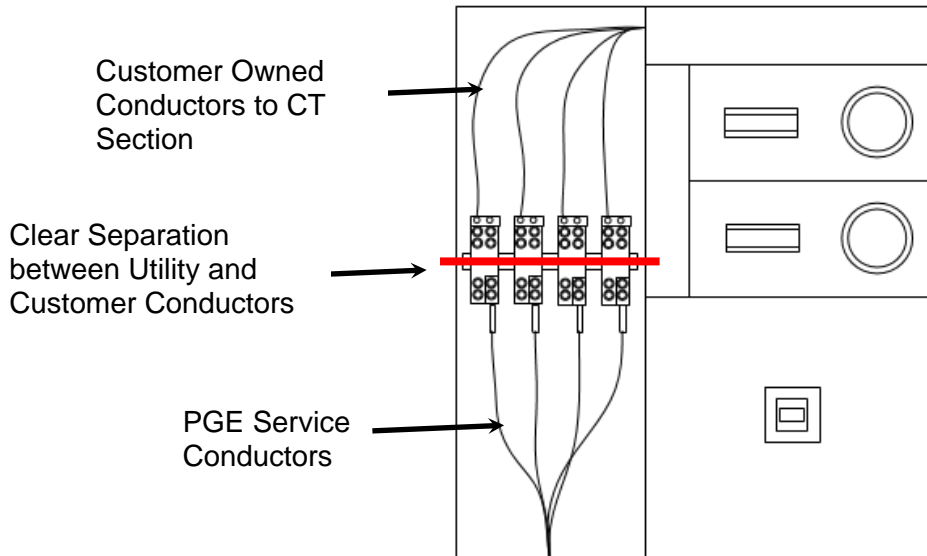

Figure 6: Switchboard Pull Section with Clear Separation

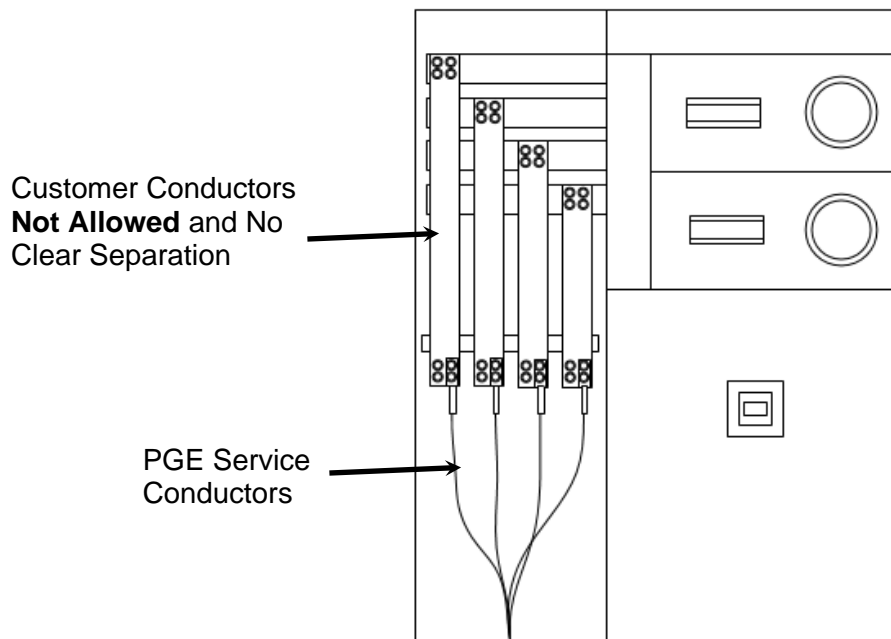

Figure 7: Switchboard Pull Section with No Clear Separation

Virtual Net Energy Metering Installations

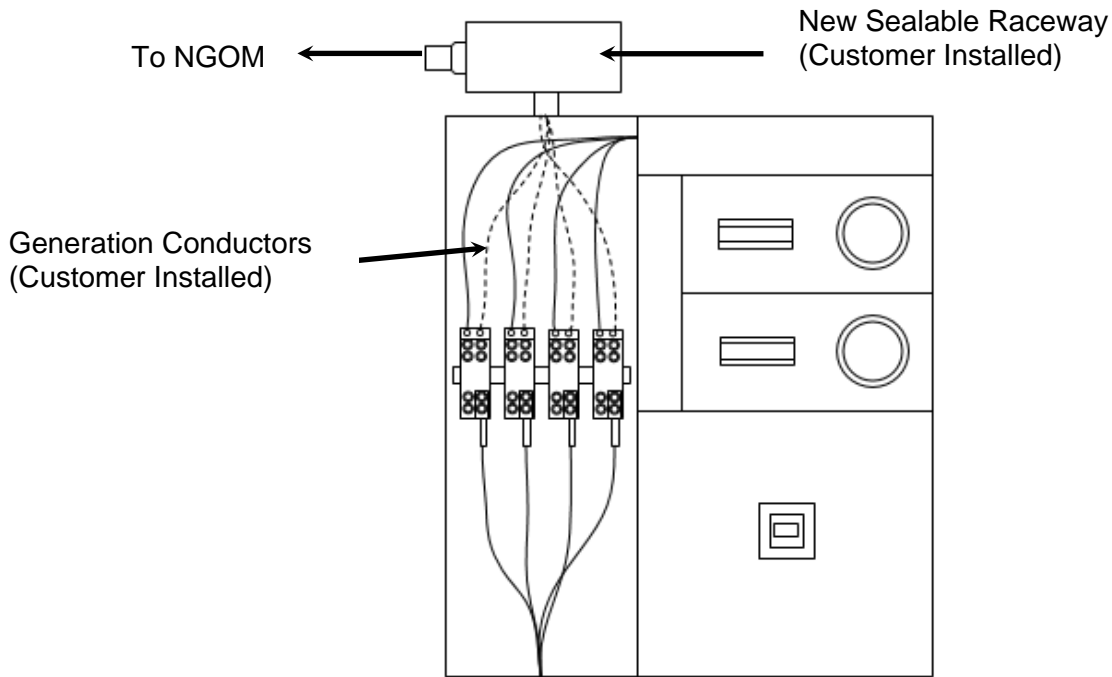

Figure 8: Point of Connection for Underground Service Switchboard

7. A fused AC disconnect switch must be installed within 10 feet and line of sight to the PGE meter. The fused AC disconnect switch must all meet all of the PG&E requirements as described in Numbered Document [060559, Disconnect Switch Requirements For Distributed Generation Customers](#).
8. Final inspection requirements:
 - All equipment has been approved by PG&E and the local (city/county) inspection agency or the authority having jurisdiction.
 - VNEM point of connection has been reviewed and approved by all of the appropriate PG&E departments.
 - The appropriate signage and maps are displayed to easily locate the VNEM meter panel and AC disconnects.

Virtual Net Energy Metering Installations

DOCUMENT APPROVER

Alex Yan, Meter Engineering Supervisor

DOCUMENT CONTACT

Albert Pham, Senior Meter Engineer, 415-973-6412

INCLUSION PLAN

This Bulletin will reside on PG&E's Technical Information Library and will be in effect until cancelled or incorporated by another document.

The information in the Bulletin will be included into the *Electric and Gas Service Requirements (Greenbook) Manual*.

Requirements for Line Side Interconnections for Distributed Generation

SUMMARY

This bulletin describes requirements for any line side interconnections performed on 0-600 Volt meter panels and switchboards for Distributed Generation (DG) customers. Any type of modification made to metering equipment that interconnects a customer generation source ahead of the main service disconnect is considered a line side or supply side interconnection.

Level of Use: Informational Use

AFFECTED DOCUMENT

N/A

TARGET AUDIENCE

PG&E customers that are interconnecting an approved generation system under the Rule 21 tariff and PG&E employees who perform customer contact and electric field work.

WHAT YOU NEED TO KNOW

General Requirements

PG&E's preferred interconnection for distributed generation interconnections is on the load side of the panel, after the service main disconnect. This interconnection is described in National Electrical Code (NEC) 705.

For line side interconnections the following requirements apply.

1. **A variance request must be submitted** to the PG&E Electric Generation Interconnection department for review by Electric Metering Engineering and Electric Distribution Standards departments.
2. The interconnection must be between the PGE meter and main breaker in the customer section of the equipment and not in the PG&E, termination, metering, or other sealed compartment or section.
3. Generation conduit and conductors must not be routed through any PGE sealed sections for the purpose of interconnection.
4. A fused AC disconnect switch must be installed within 10 feet and line of sight to the PGE meter. The fused AC disconnect switch must all meet all of the PG&E requirements as described in Numbered Document [060559, Disconnect Switch Requirements For Distributed Generation Customers](#).
5. The Authority Having Jurisdiction (AHJ) must sign off and approve the line (supply) side interconnection and fused AC disconnect before PG&E will re-energize. PG&E also recommends the interconnection proposal and single line diagrams are pre-approved by their AHJ.

Requirements for Line Side Interconnections for Distributed Generation

6. The Authority Having Jurisdiction (AHJ) must sign off the building permit for the generation system before PG&E will give the final approval to operate.
7. Residential “solar ready” service panels designed with an alternative energy (customer generation) interconnection circuit breaker on the line side of the main breaker is allowable. “Solar ready” panels must be EUSERC approved and have factory installed labels showing location and ratings of the generation source
8. New pad-mounted (floor-standing) switchboards must have a separate compartment / section for line side connections.

Specific Requirements

1. For line side interconnection requests, developers must submit the following to EGI for review:
 - a. Single line diagram
 - b. Detailed drawings and pictures showing the point of interconnection
 - i. Drawings must provide specific details on where in the compartment section and how the interconnection will be made.
 - ii. Pictures must show the whole service panel and marked-up where the interconnection will be.
2. Figures 1-3 below distinguishes separation between PG&E’s and the customer’s section and also the designated line side interconnection locations.

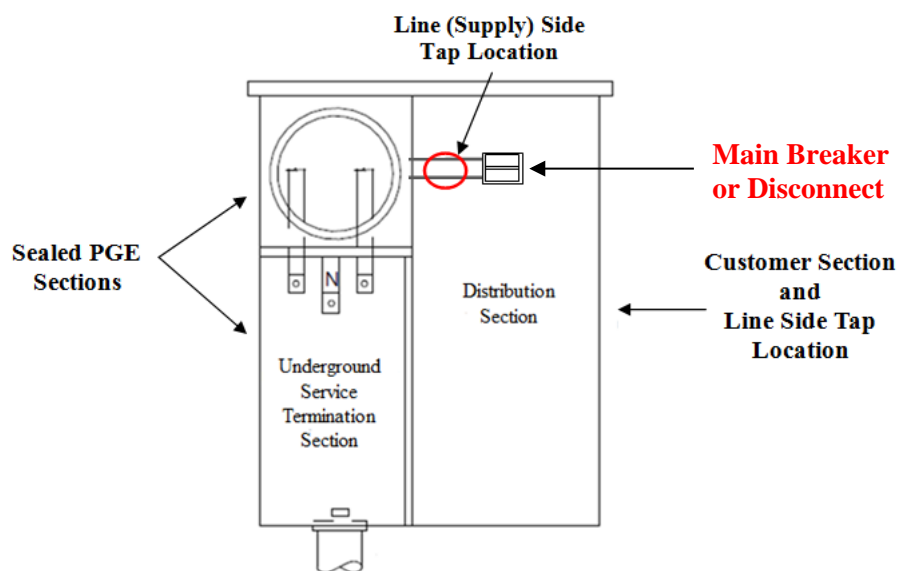

Figure 1. Typical Wall-Mounted Meter Panel

Requirements for Line Side Interconnections for Distributed Generation

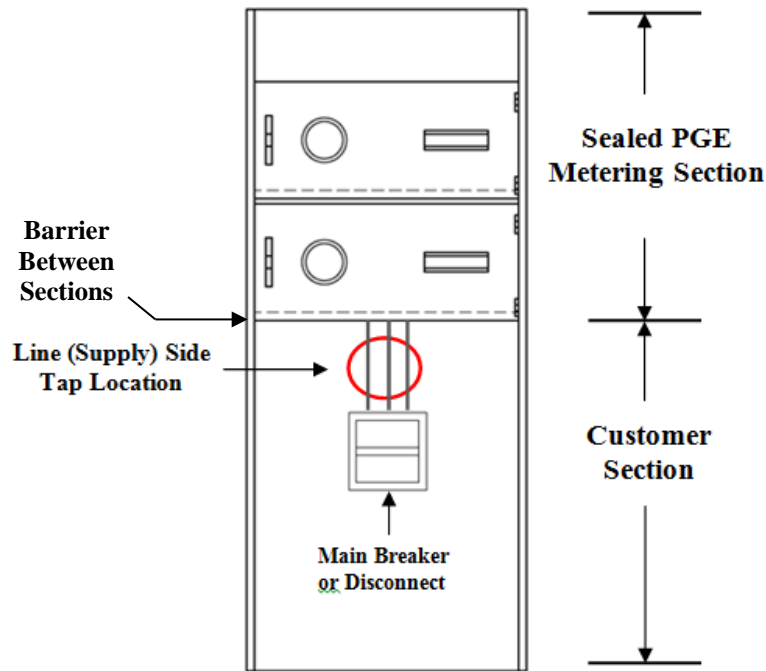

Figure 2. Switchboard with Metering Section Above the Main Breaker Section

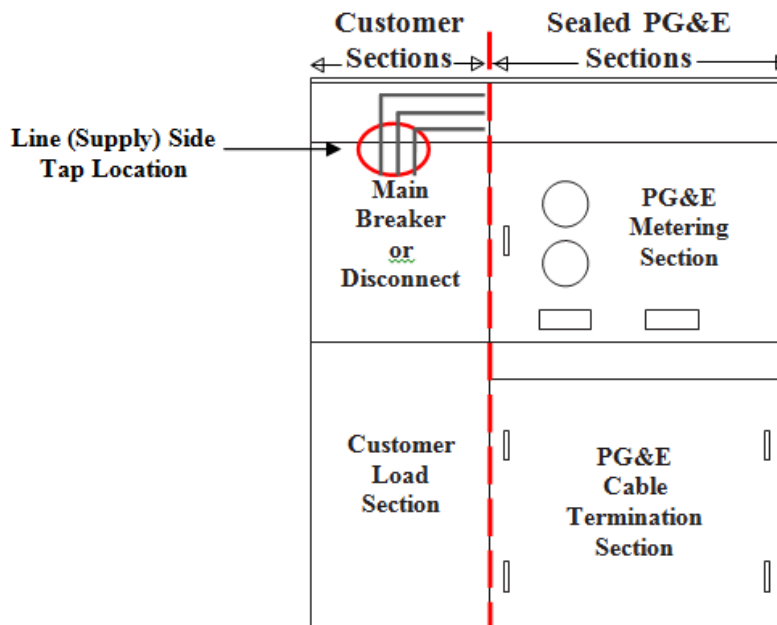

Figure 3. Switchboard with Metering Section Above the Termination Section

Requirements for Line Side Interconnections for Distributed Generation

DOCUMENT APPROVER

Alex Yan, Meter Engineering Supervisor

DOCUMENT CONTACT

Albert Pham, Senior Meter Engineer, 415-973-6412

INCLUSION PLAN

This Bulletin will reside on PG&E's Technical Information Library and will be in effect until cancelled or incorporated by another document.

The information in the Bulletin will be included into the *Electric and Gas Service Requirements (Greenbook) Manual*.

Installing 600 Volt Current Transformers

SUMMARY

This bulletin provides information on changes to existing requirements when installing 600 V metering current transformers (CT's) for new service. Changes for CT installations will be addressed on new CT installs for underground service switchboards rated at 600 V or less.

Informational Use

AFFECTED DOCUMENT

Utility Procedure: TD-6301P-01, "Electric Metering – Safe Work Procedures", Attachment 1 Installing 600 Volt Current Transformers

2017 Electric & Gas Service Requirements (Greenbook)

TARGET AUDIENCE

All field personnel and customer service representatives.

WHAT YOU NEED TO KNOW

To ensure the safety of field metering personnel, CTs will be installed on new services before the service conductors are terminated in the utility pull section. If service conductors have already been installed, validate or create an open point that is **controllable** on the **source** and **load** side of the metering section.

Review Utility Procedure: TD-6301P-01, "Electric Metering – Safe Work Procedures", Attachment 1 Installing 600 Volt Current Transformers, for detailed instructions.

Wall-mounted transformer-rated panels are an **exception** where the applicant's service-entrance conductors **must** be installed before CTs are installed. In this case, validate or create a controllable open point on the source and load side of the metering section.

In addition, the 2017 Greenbook will communicate to developers and service planning representatives requiring CTs to be installed before service conductors are terminated with the requirement below:

"When applicants furnish and install approved service-entrance conductors on services requiring current transformers for metering, the service-entrance conductors must be installed after PG&E installs the current transformers. At the time of delivery or installation of the service panel equipment, applicants must contact the local PG&E project coordinator to request a current transformer metering installation prior to the applicant installing the service-entrance conductors.

Exception: *An applicant's service-entrance conductors must be installed before PG&E installs current-transformers for wall-mounted transformer-rated panels."*

The Greenbook Committee will determine which section(s) this requirement will reside in.

Installing 600 Volt Current Transformers

DOCUMENT APPROVER

Young Nguyen, Sr. Manager, Meter Engineering Programs & Technology

Craig Kurtz, Sr. Manager, Field Meter Operations

DOCUMENT CONTACT

Albert Pham, Sr. Meter Engineer, 415-973-6412

INCLUSION PLAN

This information will be included in the Technical Information Library.

New Construction Requirements for Installation of Secondary Terminations in Customer Panels Requiring Current Transformer (CT) Installation

SUMMARY

This bulletin provides new construction requirements for installation of secondary terminations at customer panels when current transformers (CTs) have not been installed.

Level of Use: Informational Use

AFFECTED DOCUMENT

[TD-2424P-01, "Distribution Transformer Operations"](#)

[TD-7001M, "Electric & Gas Service Requirements"](#)

TARGET AUDIENCE

All personnel who schedule, install, inspect, or supervise installation of secondary terminations at customer electric panels.

WHAT YOU NEED TO KNOW

To prevent inadvertent energizing of secondary voltage before installation of current transformers (CTs), the following procedures will apply:

- Secondary cable should not be terminated/landed at customer panel until CTs have been installed by meter tech personnel.
- Best practice is to schedule CT installation prior to construction/installation of secondary terminations.

IF secondary terminations are installed, terminated, and CTs are not set:

THEN before the work is performed by meter personnel (i.e., installation of CTs), per the [Protective Grounding Manual, Section 4B.4.2.A.2](#), DO one of the following:

- ESTABLISH a "Visible Open" to isolate the secondary terminations for meter personnel, OR
- INSTALL shunts/grounds.
- A "Visible Open" is defined as follows:
 - **Overhead Construction:** Open cutouts, primary jumpers not installed, OR secondary cable terminations isolated.
 - **Underground Construction:** Fuses removed, i.e., bayonet fuses at padmount or subsurface transformer, OR secondary cable terminations isolated.

NOTE: An open secondary breaker is not considered a "Visible Open."

New Construction Requirements for Installation of Secondary Terminations in Customer Panels Requiring Current Transformer (CT) Installation

DOCUMENT APPROVER

Jerry Meleski, Manager

DOCUMENT CONTACT

Al Valenzuela, Distribution Specialist

INCLUSION PLAN

The content of this bulletin will be incorporated into the following documents at the time of their next revision:

- Utility procedure [TD-2424P-01, "Distribution Transformer Operations."](#)
- [TD-7001M, "Electric & Gas Service Requirements" \(Green Book\).](#)

Street Light Conduit Detail

- Notes:
1. PG&E inspector to make all final decision about trench and duct installation.
 2. Do not exceed 300 degrees in any primary or secondary conduit run.
 3. PG&E to inspect all work performed by applicant.
Applicant to call PG&E inspector 48 hours in advance.
 4. Trench work buried without being approved by inspector will be re-opened by applicant.
 5. All conduits to be proven free by means of mandrel with PG&E inspector present.
 6. 2" conduit horizontal bends to be 3' radius minimum and 2' radius minimum vertical bends.
 7. All ducts to be temporarily capped by applicant with temporary caps or rigid unglued to prevent debris from entering duct.
 8. Polyester pull tape (code: 560154) shall be used for all primary and secondary ducts.
 9. All conduits to be terminated with belled ends.
 10. Use approved conduit for underground installations.

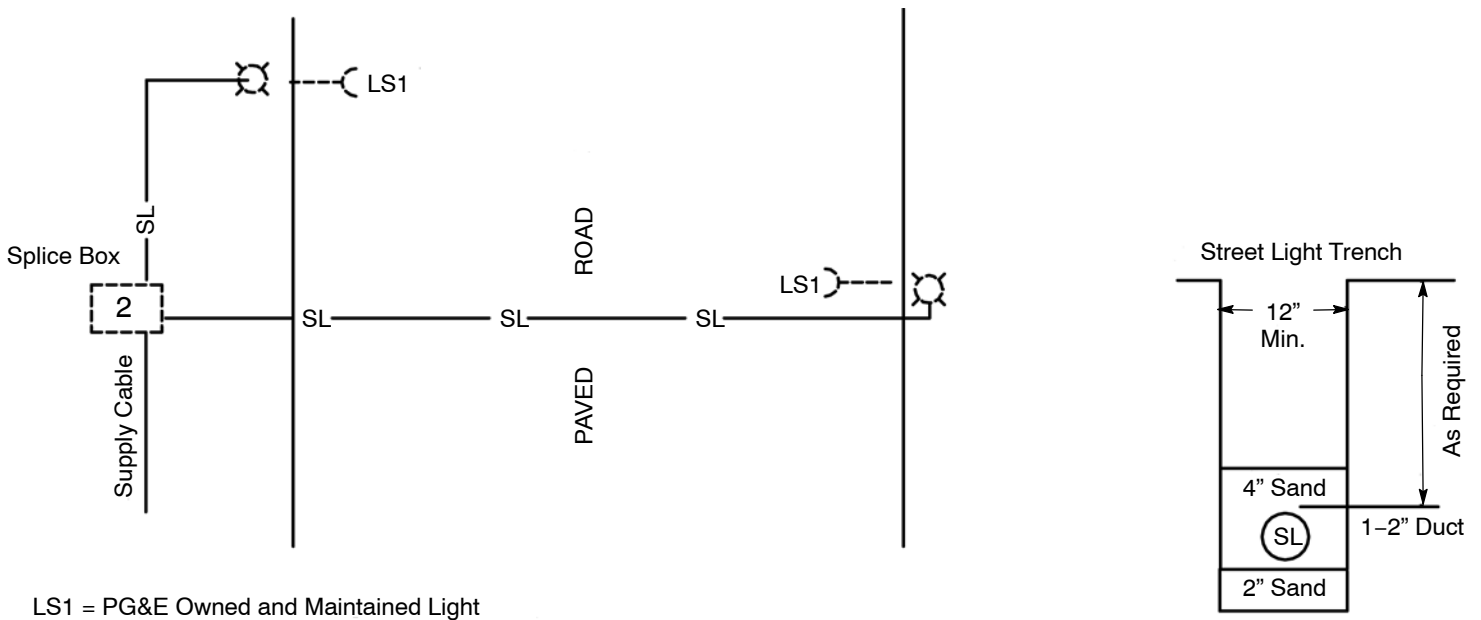
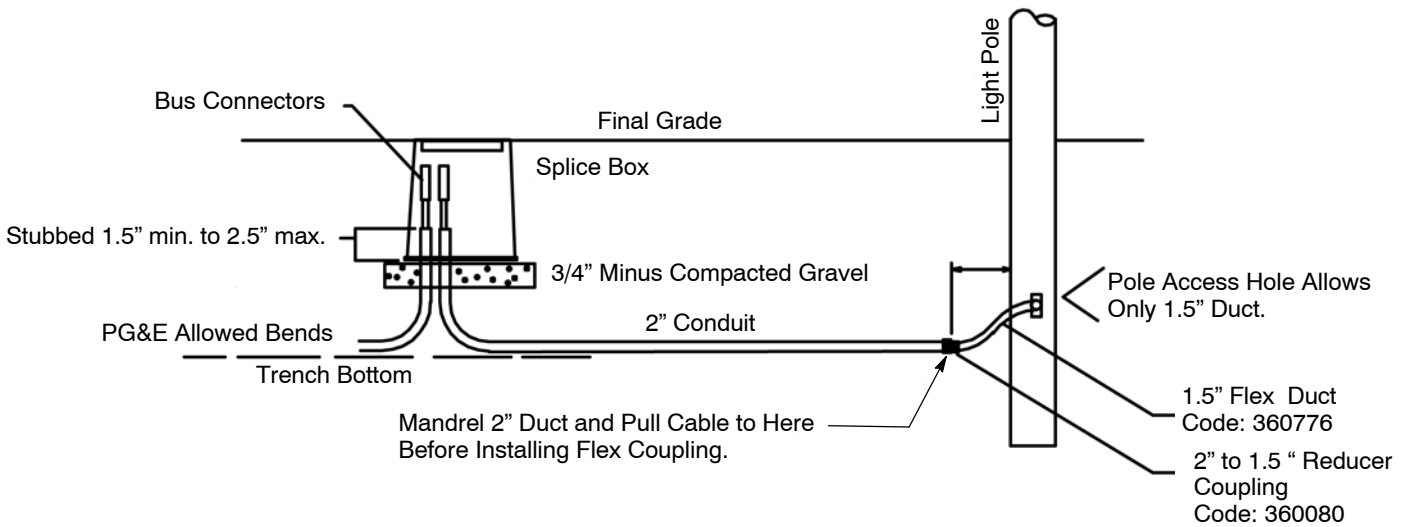



Flame Resistant (FR) Requirement Letter

Dear Customers and Contractors,

As you may be aware, PG&E has been in the process of implementing new work procedures for employees who may be exposed to Arc Flash Hazards. As of January 1, 2009 all impacted PG&E departments are now required to wear Flame Resistant (FR) clothing. This same FR requirement will also apply to,

- 1) Contractors working for PG&E.
- 2) Personnel or anyone working on or around PG&E facilities or equipment as of March 1, 2009.

The FR clothing requirement is a significant change for everyone performing work on or around PG&E facilities and equipment. On March 1st PG&E began posting signage on substations, switch yards, power plants as well as other facilities that have been designated as areas with an FR requirement. This means that access to such facilities will require everyone to be in FR clothing. PG&E facilities such as vaults, primary and secondary enclosures, pad-mounted and subsurface equipment may not have posted signage but still require everyone working in or around these facilities to be in FR clothing. Work will not be able to be performed in and around such facilities without all personnel, including non PG&E personnel, wearing the appropriate level of FR clothing.

The technical requirements listed in the "Arc Flash Summary Table" on page 2, will help you determine who needs to be in FR clothing, what level is required, and when.

Four pre-screened suppliers that sell FR clothing are identified on page 3 for your convenience.

To ensure that we address all your questions and concerns regarding this important change, please feel free to email us at AFHProgramCommittee@pge.com. A member of our implementation committee will get right back to you.

PG&E's commitment to safety is at the heart of this important change. We appreciate your support in ensuring the highest levels of safety for all that work on or around PG&E's facilities.



Flame Resistant (FR) Requirement Letter

Arc Flash Assessment Summary

PG&E has completed arc flash hazard assessments on its electrical systems. A summary of the maximum identified hazards are shown in the table below. Every person shall ensure that they wear Flame Resistant (FR) clothing that has an arc rating greater than or equal to the available heat energy whenever they are within the Arc Flash Boundary. In addition, everyone shall ensure that they wear clothing that cannot melt or ignite and continue to burn in the presence of electric arcs to which personnel could be exposed, whenever they are working on or around PG&E electrical facilities. All garments shall have tags visible from the outside that clearly identifies the garment as Flame Resistant (FR) and clearly indicates the arc rating (HRC category) of the garment. All garments shall have a minimum rating of HRC 2.

Arc Flash Summary Table

Work Area Description	Maximum Arc Flash Hazard (cal/cm²)	Maximum Arc Flash Boundary (feet)
500kV at 135"	6	20
230kV at 63"	13	15
115kV at 40"	24	12
60kV-70kV at 36"	16	9
4kV-12kV at 25"	25	9
12kV -34kV at 28"	25	9
4kV-21kV at 15" (Rubber Glove)	25	9
4kV-21kV Switchgear	100	85
120V-480V Line Equipment	8	5.5
120V-240V Meters	8	5.5
480V Self-contained Meters	25	15
480V CT Meters	8	5.5

Additionally, everyone shall be required to wear FR clothing when climbing electrical towers or when entering posted PG&E facilities. The table above shows the maximum hazards for all of PG&E equipment. Electrical equipment located in powerhouses, power plants, gas compressor stations, office buildings and warehouses have widely varying arc flash hazards. In these locations, individual equipment will be labeled with the arc flash hazard information.



Flame Resistant (FR) Requirement Letter

Flame Resistant Clothing Suppliers

The names of some Flame Resistant (FR) clothing suppliers listed below are in case you wish to contact them (the suppliers are listed in alphabetical order.) Each of these suppliers should be able to provide the necessary FR clothing required by PG&E.

Aramark Uniform Services www.aramark-uniform.com

[Jerry Hunt](#), Regional Account Executive

Office: 925-672-2641
Cell: 925-389-1853
Fax: 925-672-2741
Email: jerry.hunt@uniform.aramark.com

Cintas www.cintas.com

[Michael Burns](#), Catalog Specialist

777 139th Avenue, San Leandro, CA 94578
Office: 510-352-6330
Cell: 925-980-2434
Fax: 510-352-0348
Email: burnsm@cintas.com

Program Management International (PMI) www.pmionline.us

[Renee Ramos-Hitzel](#), President

27 Spectrum Pointe, Suite 309, Lake Forest, CA 92630;
Office: 949-215-5750
Cell: 949-302-5550
Toll Free 800-984-3201
Fax: 714-464-4186
Email: renee@pmionline.us

Tyndale www.tyndaleusa.com

[Brian Degerness](#), Regional Sales Representative

32716 Viewcrest Drive, Warren, OR 97053
Office: 503-366-3507
Cell: 503-396-1703
Toll Free 888-366-3507
Fax: 503-961-0668
Email: bdegerness@tyndaleusa.com



Flame Resistant (FR) Requirement Letter

It is the responsibility of each customer to check with the suppliers to determine their pricing, ability to meet the minimum PG&E specifications [i.e., Hazard/Risk Category (HRC) of 2 - minimum arc rating required for the protective garment], and availability. The contact information listed for each of these suppliers is provided for your information only and is not an endorsement of one supplier over another.

Sincerely,

PG&E Arc Flash Hazard Program Committee

Updated Separation Requirements For Conduit in Joint Trench

SUMMARY

This utility bulletin updates [Electric Standard 062288, "Underground Conduits"](#) and [Utility Standard S5453, "Joint Trench"](#) with the requirements listed below:

The minimum separation requirement must be 1.5 inch (in.) between:

- Secondary to: Secondary, service, and streetlight conduit
- Service to: Service and streetlight conduit

The minimum separation requirement must be 3 in. between:

- Primary-to-primary conduit
- Primary to: Secondary, service, and streetlight conduit

This increase in separation is required to improve access to the conduits during future maintenance, re-routing and replacement of the facilities.

Note that the 3 in. requirement above is already included in [Electric Standard 062288](#) but **not** in [Utility Standard S5453](#).

Additionally, separation requirements between Pacific Gas and Electric Company (PG&E or Company) Joint Trench utilities and Non-PG&E owned Foreign Electric duct (e.g., non-PG&E Streetlight) have been added to the updated Table, "Minimum Separation and Clearance Requirements (Inches)", in this utility bulletin. These are not new requirements, but they were not previously located in the Exhibit B table.

The requirements of this bulletin apply to any PG&E job estimate and any PG&E design jobs for New Business and Work Request by Others (NB/WRO), and on any Applicant Design jobs where Globals are issued after the effective date of this bulletin (7/31/2015).

AFFECTED DOCUMENT

[Utility Standard S5453, "Joint Trench"](#)

[Utility Standard S5453, Exhibit B, "Joint Trench Configurations and Occupancy Guide"](#)

[Electric Standard 062288, "Underground Conduits"](#)

TARGET AUDIENCE

Personnel in: electric construction, electric distribution engineering, electric estimating, gas distribution estimating, gas distribution engineering, customer service delivery estimating, and gas construction management.

Updated Separation Requirements For Conduit in Joint Trench

WHAT YOU NEED TO KNOW

[Utility Standard S5453, "Joint Trench," Exhibit B](#), currently shows:

		MINIMUM SEPARATION AND CLEARANCE REQUIREMENTS					
		G	DUCT T	DB T	C	S	P
G	(GAS) SEE NOTES 4, 7 & 13	—	12"	12"	12"	6"	12"
T	(TELEPHONE) DUCT	12"	—	1"	1"	12"	12"
T	(TELEPHONE) DIRECT BURY	12"	1"	—	1"	12"	12"
C	(CATV)	12"	1"	1"	—	12"	12"
S	(ELECTRIC SECONDARY)	6"	12"	12"	12"	—	3"
P	(ELECTRIC PRIMARY)	12"	12"	12"	12"	3"	—
SL	(STREETLIGHT) SEE NOTE 5	6"	12"	12"	12"	1"	3"

[Utility Standard S5453, "Joint Trench," Exhibit B](#), is updated per this bulletin as follows:

MINIMUM SEPARATION AND CLEARANCE REQUIREMENTS (Inches)								
		G	DUCT T	DB T	C	S	P	SL
G	(GAS) SEE NOTES 4, 7, & 13	-	12	12	12	6	12	6
T	(TELEPHONE) DUCT	12	-	1	1	12	12	12
T	(TELEPHONE) DIRECT BURY	12	1	-	1	12	12	12
C	(CATV)	12	1	1	-	12	12	12
S	(ELECTRIC SECONDARY)	6	12	12	12	1.5	3	1.5
P	(ELECTRIC PRIMARY)	12	12	12	12	3	3	3
SL	(STREETLIGHT) SEE NOTE 5	6	12	12	12	1.5	3	1.5
FE*	(FOREIGN ELECTRIC SOURCES, NON-PG&E*) SEE NOTE 5	12	12**	12**	12**	12	12	12

*Must be considered a 'Utility' as defined in [Utility Standard S5453, "Joint Trench."](#)

Notes 4, 5, 7, and 13 are located in [Utility Standard S5453, Exhibit B, "Joint Trench Configurations and Occupancy Guide."](#)

**For exceptions, refer to [G.O. 128 rule, Section B, Items \(1\) and \(2\).](#)

Updated Separation Requirements For Conduit in Joint Trench

DOCUMENT APPROVER

Jim Herren, Manager, Gas Distribution Engineering and Design

DOCUMENT CONTACT

Lisbeth Villareal, Electric Standards Engineer, Sr

David Krause, Gas Engineer, Codes and Standards - Design and Construction

John Pickering, Expert Business Process Analyst, Distribution Engineering and Design Support

Daniel Jantz, Expert Engineering Standards Technical Specialist, EAM Distribution Standards

INCLUSION PLAN

This update will be included in the next revision of [Electric Standard 0662288 "Underground Conduits"](#) and [Utility Standard S5453, "Joint Trench," Exhibit B.](#)

TYPICAL DISTRIBUTION TRENCH

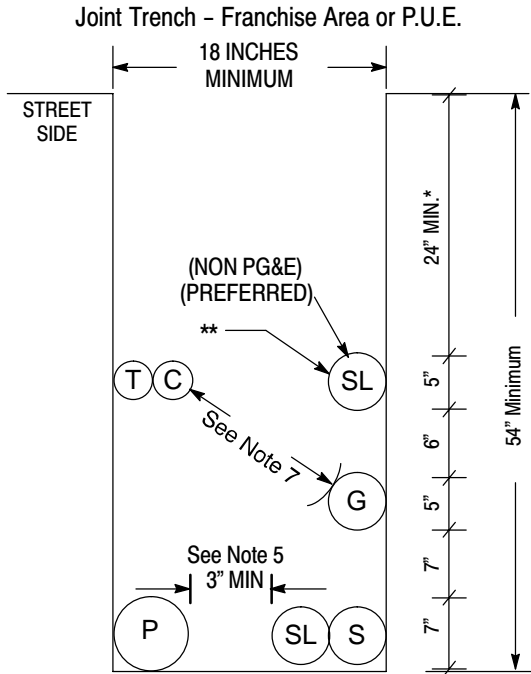

FIG. 1

Placement of the Distribution Trench within a P.U.E. is the preferred method. Trenching in the Franchise Area should only be used when a P.U.E. is unobtainable or otherwise infeasible.

* Increase cover to 30" in the street area (see Note 3).

** Separation must be 12" unless a reduction (6") is mutually agreed upon by affected utilities.

TYPICAL SERVICE TRENCH

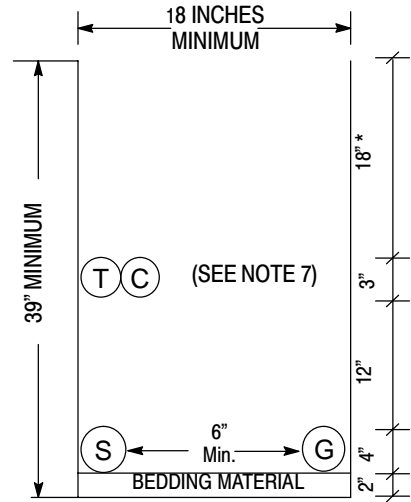

FIG. 2
(View facing Distribution Trench)

MINIMUM SEPARATION AND CLEARANCE REQUIREMENTS

		G	DUCT T	DB T	C	S	P
G	(GAS) SEE NOTES 4, 7 & 13	—	12"	12"	12"	6"	12"
T	(TELEPHONE) DUCT	12"	—	1"	1"	12"	12"
T	(TELEPHONE) DIRECT BURY	12"	1"	—	1"	12"	12"
C	(CATV)	12"	1"	1"	—	12"	12"
S	(ELECTRIC SECONDARY)	6"	12"	12"	12"	—	3"
P	(ELECTRIC PRIMARY)	12"	12"	12"	12"	3"	—
SL	(STREETLIGHT) SEE NOTE 5	6"	12"	12"	12"	1"	3"

SEPARATION AND CLEARANCE DEFINITIONS

Cover:

The term "cover" means the radial distance between the surface of an underground cable, conduit, pipe, or other substructure and the surface elevation (grade).

Backfill:

The term "backfill" refers to the materials used to refill a cut or other excavation, or the act of such refilling after any needed shading is performed.

Shading:

The term "shading" refers to the materials used to provide a measure of separation between facilities installed at different levels within an excavation or cut.

Lift:

The term "lift" is a layer of fill as spread or as compacted or a measurement of material depth that is the rated effective soil depth a compactor can achieve.

Bedding:

The term "bedding" refers to the materials installed beneath facilities at the bottom of a cut or other excavation and intended to provide support and/or protection for those facilities.

STANDARD TRENCH LOCATIONS

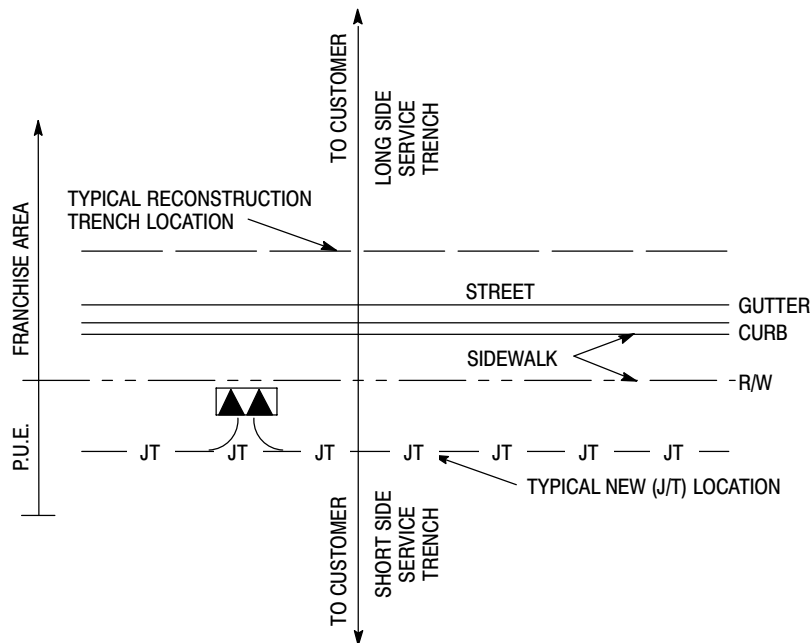

JOINT TRENCH CONFIGURATIONS & OCCUPANCY GUIDE

09-27-06

OTHER TYPICAL PG&E DISTRIBUTION JOINT TRENCH CONFIGURATIONS

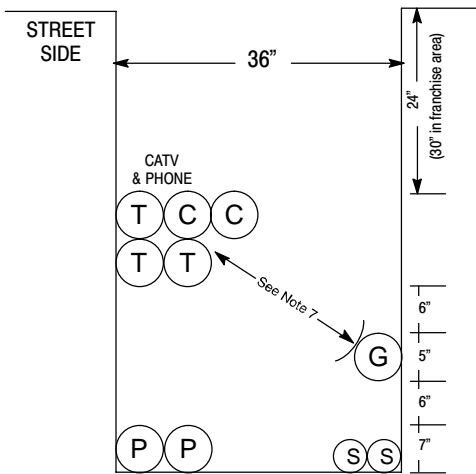

FIG. 3
36" Wide Joint Trench

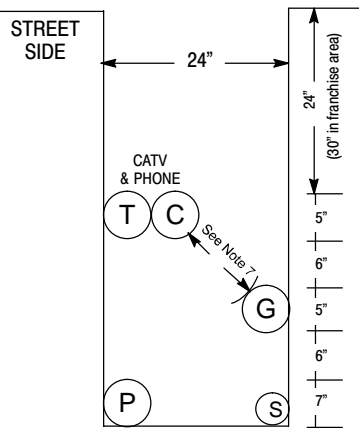

FIG. 4
24" Wide Joint Trench

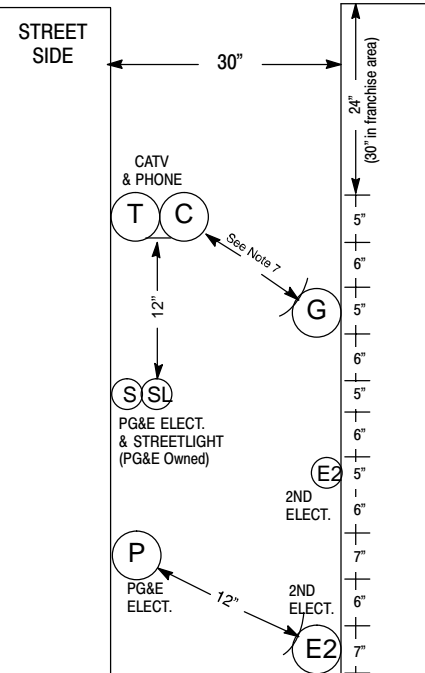

FIG. 5
Joint Trench With Second Electric Utility

Trench Configuration Notes

The trench configurations shown in this guide are to be considered "typical" only and that other trench widths, depths, as well as utility configurations (placement) may be used, provided all minimum requirements for separation, clearances, and cover are observed. In no case shall electric primary or secondary (excluding street lighting) be placed at a level higher than that of the gas and communications level. Gas shall be placed at the same level or below communications when gas is placed above the electric facilities.

Special Notes for Joint Trench With Second Electric Utility

- A. Refer to Sheet 3 for General Notes.
- B. A red 3-inch wide "PG&E Electric Line in Conduit" plastic marking tape, Code 375054, shall be installed, spiral wound in a manner that allows for the tape to be readily visible every 3 feet, with each conduit intended to be used for PG&E electric facilities. An equivalent red tape marked to identify the owner shall be installed with the conduit intended to be used for the second electric facility.
- C. Each utility shall ensure adequate grounding between electric facilities is provided (See [UO Standard S5453](#), "Joint Trench").
- D. Provide a minimum of 2 inches of compacted PG&E approved bedding material as a trench leveling concourse, where required. See General Notes Items 11 and 12 (on Page 3), in order to obtain proper compaction.

JOINT TRENCH CONFIGURATIONS & OCCUPANCY GUIDE

09-27-06

General Notes

1. The preferred trench location is in a Public Utility easement (P.U.E.).
2. All depths and resulting cover requirements are measured from final grade.
3. Cover, clearances, and separation shall be as great as practicable under the circumstances, but under no circumstances shall be less than the minimum cover, clearance, and separation requirements set forth in [General Order 128](#) and [49CFR 192.321](#), [49CFR 192.325](#), and [49CFR 192.327](#). All facilities shall be anchored in place prior to compaction, or other means shall be taken to ensure no motion of the facilities. Dimensional requirements for shading, leveling, and backfilling shall be determined subsequent to compaction.
4. Trench dimensions shown are typical. Trench sizes and configurations may vary depending upon occupancy and/or field conditions. Trench size and configuration must at all times be constructed in a manner that ensures proper clearances and cover requirements are met. Any "change" to the trench width and configurations as shown in this exhibit must be designed to ensure this requirement.
5. It is preferred to have non-PG&E owned streetlights at a level other than the gas or electric level. Non-PG&E owned streetlights may be at the electric level of the trench as long as minimum clearances are provided and comply with all special notes for a joint trench with a second electric utility.
6. Non-Utility facilities are not allowed in any Joint Utility trench, e.g., irrigation control lines, building fire alarm systems, private telephone systems, outdoor electrical cable, etc.
7. When communication ducts are installed, a minimum of 12" radial separation shall be maintained from gas facilities. Exception: With mutual agreement, when 4-inch diameter or smaller gas pipe is installed, the separation may be reduced to not less than 6 inches.
8. Provide separation from trench wall and other facilities sufficient to ensure proper compaction.
9. Maintain proper separation between PG&E facilities and "wet" utility lines as described in [UO Standard S5453](#). The minimum allowable horizontal separation between Company facilities and "wet" facilities is 3' with a minimum 1' of undisturbed earth or the installation of a suitable barrier between the facilities.

If a 3' horizontal separation cannot be attained between "wet" utilities and Company dry facilities, a variance may be approved by the local Inspection Supervisor and submitted to the Service Planning Support Program Manager for approval. Separations of 1' or less are not permissible and will not be allowed. The Company may agree to waive the minimum 3' separation requirement at the request of an applicant if warranted and the need is justified. The request for a waiver must:

- Be made in writing and submitted to the Company ADE during the planning and design phase of the project,
- Clearly describe the conditions necessitating the waiver,
- Include a proposed design,
- And, include a design for a barrier between the "wet" utilities and Company dry facilities in the event 1' of undisturbed earth cannot be maintained.

Note: Drain lines connected to downspouts on buildings are considered a "wet" utility for the purposes of this standard.

10. Separations shall be maintained at aboveground termination points.
11. Procedures for approving native backfill for shading of PG&E gas facilities:
 - Random soil samples shall be taken from a minimum of 3 locations per 1,000' of trench. 100% of the sample must pass through a 1/2" sieve and 75% must pass through a #4 screen. Additional samples must be taken if existing soil conditions change and are to be taken at the discretion of the PG&E representative on site.
 - The soils must not contain any rocks that have sharp edges or that may otherwise be abrasive.
 - The soils must not contain clods larger than 1/2" if to be used as shading, bedding, or leveling materials.
 - Compaction requirements must meet any applicable PG&E, Federal, State, County, or local requirements.
 - At no time shall the over saturation of native soils be used to achieve these requirements.

The sieves and screens shall be:

- 1/2" Sieve: 8" diameter by 2" deep, stainless steel mesh screen.
- #4 Screen: 8" diameter by 2" deep, stainless steel mesh screen.

Notes continued on the next page

JOINT TRENCH CONFIGURATIONS & OCCUPANCY GUIDE

09-27-06

General Notes, continued

12. Procedures for approving native backfill for shading at PG&E electric facilities:
- Random soil samples shall be taken from a minimum of 3 locations per 1,000' of trench. Additional samples must be taken if existing soil conditions change and are to be taken at the discretion of the PG&E representative on site.
 - Shading material containing large rock, paving material, cinders, sharply angular substances, or corrosive material shall not be placed in the trench where such material may damage the conduits and/or prevent proper compaction over or around the conduits.
 - Native soils containing clods not to exceed 6" in diameter may be included in the shading material provided the clods are readily breakable by hand.
Note: Soils consisting primarily of adobe, hard compact (dense) clay, and bay muds shall not be used as shading material.
 - At no time shall the over saturation of native soils be used to achieve these requirements.
 - Refer to [Engineering Document 062288](#), Item 13 on Page 2.
13. Competent native soils are preferred to be used for shading, bedding, and backfilling throughout the trench.
- Where native soils exceed 1/2" minus and/or where gas is to be placed at the bottom of a trench in areas that exceed 1/2" minus soil conditions, or where the bottom of a trench is considered to consist of hard pan, PG&E approved 1/2" minus import material shall be used for shading and/or bedding of gas facilities.
 - PG&E approved import material is per [CGT Engineering Guideline 4123](#).
 - If a leveling course is required for gas facilities, the use of native soils is preferred, but if 1/2" minus conditions are not attainable with the native soils, then the use of PG&E approved import materials is required. Bedding under gas facilities will be a minimum of 2" of compacted 1/2" minus native soils or PG&E approved import material.
 - For electric facilities, refer to Note 12. This applies to leveling courses as well as shading.
 - The minimum PG&E approved bedding material may be increased at the discretion of PG&E when warranted by existing field conditions (e.g., rocky soils, hard pan, etc.).
 - The use of any imported material for backfilling purposes shall be limited to those situations when native soils do not allow for required compaction.
14. The applicant is responsible for the removal of excess spoil and associated costs.
15. Separation between gas facilities and electric facilities may be reduced to 6" when crossing.
16. Service saddles are the preferred service fittings for use throughout the joint trench project. All projects will be designed and estimated using service saddles. However, service tees may be used if all clearances, separation, and coverage requirements are maintained.

Revision Notes

1. Revised Note 9 to clarify the minimum allowable horizontal separations requirements.
2. This document was revised on 09-27-2006.

JOINT TRENCH CONFIGURATIONS & OCCUPANCY GUIDE

09-27-06



Document Type	Engineering material specification (EMS)
Workflow	Major Revision

1. Why is the guidance document being written / revised?

This specification is being revised to align content with engineering and industry specifications, requirements, and best practices.

2. Is the guidance document new or revised? If it is revised, what will change? If new, what is the topic?

Updated changes are based on a review of the Rev. 0 specification, historical specifications, industry benchmarking, American Society of Materials Testing (ASTM) specifications, Caltrans and other industry specifications, research and review of civil and geotechnical references, and discussions with engineering, construction, inspection, sourcing and external suppliers. See Table 1, "Revision Changes."

Table 1. Revision Changes

Section	Revision 0	Revision 1
Organic Impurities	Equal to or less than 3	NA
Sand Equivalent	>20	NA
pH	4.5-9	4.5-9
Resistivity	>5000	>3000
Gradation Requirements	% Passing	% Passing
1/2"	100	NA
3/8"	NA	100
No. 4	75-100	90-100
No. 50	0-70	NA
No. 100	0-30	NA
No. 200	0-15	0-15
C_u	> 2.5	NA
"Compaction" will be changed to "Maximum Dry Unit Weight and Optimum Moisture Content"	95% Relative Compaction	Provide Optimum Moisture and Lab Dry Unit Weight

- Organic Impurities, as determined by ASTM C-40 requirements, is removed from the updated specification. This test is used to determine if there are "injurious organic compounds in natural sands, which are to be used in cement mortar or concrete." Organic compounds can affect the strength properties of cement. Corrosive properties of sand that can affect steel pipe are evaluated by the pH and resistivity. Plastic pipe has a high resistance to chemicals in sand.



Question 2 (continued)

- Sand Equivalent, as determined by ASTM D-2419-14, is removed from the updated specification. This test determines “relative proportions of detrimental fine dust or clay-like material in soil or fine aggregates.” As with organic impurities, excessive clay or silt in a concrete aggregate can affect the strength properties of cement. Clay or silt is not a concern when used around steel or plastic pipe. In addition, excessive fines will be minimal due to the proposed gradation requirements.
- pH value, as determined by ASTM G51-95 (2012) and ASTM D4972-13, will remain the same.
- Resistivity, as determined by ASTM G-57-06 (2012) and ASTM G187-12a, is changed to greater than or equal to 3,000 Ohm-cm.

In addition, if resistivity is less than 3,000 Ohms-cm, the following chemical content limits must apply:

- Total chloride content must be equal to or less than 500 parts per million as determined by EPA Method 300.0 prepared by Parr O2 bomb combustion.
- Total sulfate content must be equal to or less than 150 parts per million as determined by EPA Method 300.0 prepared by Parr O2 bomb combustion.
- Compaction ASTM D-1557 is updated to require the supplier to provide the optimum moisture content and lab dry unit weight.
- Gradation Requirements updated as determined by ASTM C-136 and ASTM C-117. See Table 2, “Grain Size Distribution Requirements.”

Table 2. Grain Size Distribution Requirements

Sieve	Sieve Size		% Passing
3/8"	0.375 in.	9.5 mm	100
No. 4	0.187 in.	4.75 mm	90-100
No. 200	0.00298 in.	75 µm	0-15

This update was developed using Caltrans 2015 Standard Specification section 19-3.02F(2) “Sand Beddings,” as a reference. The revised specification will provide for a backfill sand that meets the criteria for sand under ASTM D2487-14 and Class I, II and III coarse grained soils under the American Association of State Highway and Transportation Officials (AASHTO) “Soil Classification System.” A review of a benchmarking survey by the American Gas Association (AGA) revealed that participating utilities had no specific gradation requirements or had similar gradation requirements to the Rev. 1 requirements.

- 100% must pass the 1/2" and 3/8" sieve.



Question 2 (continued)

- The percent passing allowed for the No. 4 sieve (0.187 in.) is changed from 75-100 to 90-100. This change will limit the amount of larger particles that could potentially damage the pipe during backfilling and compaction.
- The requirements for the No. 50 (0.117 in.) and No. 100 (0.0059 in.) are removed. This will provide engineering, construction and applicant installers more flexibility in specifying and/or locating acceptable sand.
- The percent passing for the No. 200 (0.00298 in.) will remain the same.
- Coefficient of Uniformity (Cu) is removed, because the gradation requirements ensure that the sand is suitable to be used as bedding and shading fill around plastic and steel pipe. Neither Caltrans nor other available utility specifications require a specific Cu.
- Testing updated to detail rights reserved by PG&E. This will assist inspection with reviewing and enforcing the specification with applicant and contractor installation.

3. Does this project introduce any major new risks or change existing mitigated risks, such as Process Safety risks?

No.



4. Stakeholder Identification

The following individuals provided developmental assistance and were primary reviewers for the content in this EMS:

Department / Work Center	Role	Name	Date Reviewed
Pipeline Engineering and Design	Engineering	Joshua Hampton	05/16/2016
Distribution Integrity Management Program (DIMP) Engineering	Engineering	Mike Kerans	05/16/2016
Safety and Environmental	Environmental	Tuesdai Powers	05/16/2016
Distribution Inspection	Inspection	Jose Fletes	05/16/2016
Distribution Inspection	Inspection	Ramen Spears	05/16/2016
General Construction (GC) Gas Transmission Engineering	Primary Reviewer	Adam Linney	05/16/2016
Corrosion Services	SME	Bruce Wiskel	05/16/2016
Plant Engineering and Design	SME	John Burniston	05/16/2016
DIMP	SME	Matteo Rossi	05/16/2016
Gas Methods and Procedures	SME	Michael Lane	05/16/2016
Gas Methods and Procedures	SME	Patrick Symons	05/16/2016
Hanson Aggregates	Supplier	Chris Stromberg	05/16/2016
Far West	Supplier	Darren Fry	05/16/2016
Teichert	Supplier	John Dooley	05/16/2016
Lind Marine	Supplier	Ron Peterson	05/16/2016

A final draft of the EMS was shared with the following individuals.

Department / Work Center	Role	Name	Date Sent
TIR North Area	Construction	Brad Spainhower	05/16/2016
Maintenance and Construction (M&C) South - San Jose/De Anza	Construction	Bryan McCallum	05/16/2016
TIR Bay Area South	Construction	Cathlene Bennett	05/16/2016
TIR Central North Region	Construction	Curtis Tonetti	05/16/2016
M&C North - Sacramento	Construction	Erik Kurtz	05/16/2016
M&C South - San Francisco	Construction	James Randolph	05/16/2016
TIR Central South Region	Construction	Jason Klemm	05/16/2016
Gas Transmission and Distribution (T&D) Inspection & Contract Management	Construction	Jerry Rice	05/16/2016
M&C North - North Valley and Sierra	Construction	Joe Carlstrom	05/16/2016
M&C South - Fresno and Kern	Construction	Joe Cummins	05/16/2016



Gas Guidance Document Analysis (GDA)

For Backfill Sand

EMS-4123, Rev. 1

Department / Work Center	Role	Name	Date Sent
M&C North - Humbolt and Sonoma	Construction	Joe Ojeda	05/16/2016
Gas Transmission Construction Management - C Coast	Construction	Joey Lynn Covey	05/16/2016
M&C Gas - GC - Northern Region	Construction	John Costanza	05/16/2016
Central Operations Support	Construction	John Fiske	05/16/2016
M&C South - Stockton and Yosemite	Construction	John W Martin	05/16/2016
M&C North - Diablo and North Bay	Construction	Kevin F Souza	05/16/2016
M&C North - East Bay and Mission	Construction	Kevin P. Souza	05/16/2016
TIR Bay Area North	Construction	Lance Johnson	05/16/2016
M&C Gas - GC - Central Valley Region	Construction	Larry Hartsell	05/16/2016
M&C Central Coast	Construction	Mario Martini	05/16/2016
E2 SOW Contractor	Construction	Matt Hewitt	05/16/2016
TIR Operations & Process	Construction	Meghan Murphy	05/16/2016
GC Gas Distribution Engineering	Construction	Michael Coakley	05/16/2016
M&C Gas - GC - Bay Area Region - East	Construction	Michael Seitz	05/16/2016
GC Gas Transmission - South	Construction	Mitch Freese	05/16/2016
Gas Transmission Construction Management - C Valley	Construction	Norman Soares	05/16/2016
M&C - GC - Central Coast Region	Construction	Omar Macay	05/16/2016
Gas Transmission GC M&C/Supervisory Control and Data Acquisition (SCADA)	Construction	Peter Demartini	05/16/2016
Gas For Electric	Construction	Rhonda De Rosa	05/16/2016
M&C Gas - GC - Bay Area Region - West	Construction	Richard Salaz Jr.	05/16/2016
TIR South Area	Construction	Rick A Bezanson	05/16/2016
Gas Transmission Construction Management - Northern	Construction	Ronald Whyte	05/16/2016
Gas Transmission Construction Management - Operations	Construction	Steven Delledera	05/16/2016
M&C South - Peninsula only	Construction	Tim Bellinghausen	05/16/2016
Gas Transmission Construction Management - Bay Area	Construction	William Czabaranek Jr.	05/16/2016
Transmission Integrity Management Program (TIMP)	Corrosion	David Aguiar	05/16/2016
Pipeline Engineering and Design	Engineering	Joshua Hampton	05/16/2016
Pipeline Engineering and Design	Engineering	Ben Tai	05/16/2016
Pipeline Engineering and Design	Engineering	Brad Carr	05/16/2016



Gas Guidance Document Analysis (GDA)

For Backfill Sand

EMS-4123, Rev. 1

Department / Work Center	Role	Name	Date Sent
DIMP Engineering	Engineering	Mike Kerans	05/16/2016
Plant Engineering & Design	Engineering	Donald Yorke	05/16/2016
Hydrotesting	Engineering	Edward Stracke	05/16/2016
Pipeline Engineering & Design 02	Engineering	Francisco Castro	05/16/2016
Instrument, Controls, and Electric	Engineering	Geoffrey Jarpe	05/16/2016
Plant Engineering	Engineering	Hien Tran	05/16/2016
TIMP Engineering	Engineering	Jeff Janvier	05/16/2016
Local Engineer and Design	Engineering	Jim Rehtin	05/16/2016
Local Engineer and Design	Engineering	John D Hunter	05/16/2016
Engineering Services	Engineering	Roberto Morales	05/16/2016
Pipeline Field Services	Engineering	Roy A Surges	05/16/2016
Pipeline Services	Engineering	Ryan Weber	05/16/2016
Facilities Integrity Management Program (FIMP)	Engineering	Scott Fanin	05/16/2016
FIMP	Engineering	Timothy Scheele	05/16/2016
Pipeline Engineering & Design	Engineering	Todd Hogenson	05/16/2016
Safety and Environmental	Environmental	Tuesdai Powers	05/16/2016
Distribution Inspection	Inspection	Jose Fletes	05/16/2016
Distribution Inspection	Inspection	Ramen Spears	05/16/2016
GC Gas Transmission Engineering	Primary Reviewer	Adam Linney	05/16/2016
Pipe Replacement Workstream	Project Management	Alex Vayntrub	05/16/2016
Pipe Replacement Workstream	Project Management	Evan Stark	05/16/2016
Geosciences	Subject Matter Expert (SME)	Emily Steen	05/16/2016
Gas Methods and Procedures	SME	Jeanette Lindemann	05/16/2016
Corrosion Services	SME	Bruce Wiskel	05/16/2016
Plant Engineering and Design	SME	John Burniston	05/16/2016
Gas Methods and Procedures	SME	Lucas Huezo	05/16/2016
DIMP	SME	Matteo Rossi	05/16/2016
Gas Methods and Procedures	SME	Michael Lane	05/16/2016
Gas Methods and Procedures	SME	Patrick Symons	05/16/2016
Hanson Aggregates	Supplier	Chris Stromberg	05/16/2016
Far West	Supplier	Darren Fry	05/16/2016
Teichert	Supplier	John Dooley	05/16/2016
Lind Marine	Supplier	Ron Peterson	05/16/2016



6. Electronic Document Routing System (EDRS) Reviewers and Approvers

- Reviewers: Mariela Castellanos, Ben Tai, Joshua Hampton
- Approvers: Sean Mann, Brad Carr, Adam Linney, Lily Gharib, Jerrod Meier

7. Detail any needed cost or schedule information

Effective date: 09/07/2016

8. How often will the guidance document be reviewed?

At least once every 5 calendar years, not to exceed 63 months, to the date.

Technical Requirements for Electric Service Interconnection at Primary Distribution Voltages

SUMMARY

This bulletin specifies the technical requirements for all customers requesting electric service at one of Pacific Gas and Electric Company's (PG&E) primary distribution voltages as defined in Rule 2. It is intended to give the customer a clear understanding of what their responsibilities are to receive Primary Service (PS) and those of PG&E. PG&E has developed these technical requirements in order to provide safe and reliable service to all the customers the Company serves.

If the PS customer also intends to install generation, then also refer to the information and requirements described in the [Distribution Interconnection Handbook](#).

AFFECTED DOCUMENT

None

TARGET AUDIENCE

All utility employees working with primary service design and installation.

WHAT YOU NEED TO KNOW

1 General Requirements

Customers meeting the Rule 2 requirements for PS shall install, own and operate their distribution system beyond their Point of Service (POS). While there are a number of technical requirements associated with a PS, two requirements are particularly important:

- PG&E must approve the POS.
- PG&E must approve the protection scheme that the customer installs, owns and operates at the POS.

Satisfying these requirements assists PG&E in providing safe and reliable service to other customers connected to the Company's system. Customers considering a PS should contact PG&E early in the design process.

2 Primary Service Arrangements

PG&E prefers that the POS, protective device and revenue meter for a PS be at or near the property line nearest to PG&E's primary distribution. The PG&E-approved and customer installed primary protection must be at the POS to protect other PG&E customers from outages due to faults on customer facilities. The revenue-metering should also be at this point because the PS customer is responsible for the line losses on their primary conductor and transformer(s) as well as their load. However, unlike the requirement for the protective device, it is not an absolute requirement.

Technical Requirements for Electric Service Interconnection at Primary Distribution Voltages

The sections below explain the primary protection requirements and revenue-metering location requirements for PG&E's preferred PS arrangements. Please note that non-preferred service arrangement proposals may take longer to approve and involve additional cost for the customer.

2.1 Preferred PS Arrangements

PG&E's preferred PS arrangements are either: a) when the PS customer's primary distribution line is underground (UG) and the POS is less than 500 feet from the property line, or b) when the PS customer's primary distribution line is overhead (OH) and the protective device pole (if separate from the POS pole) is less than 50 feet from the property line.

1. UG Conductor and POS < 500 Feet

If the PS customer's primary line is underground and the POS is 500 feet or less from the property line, refer to Figure A3-1 and Figure A3-2. The following requirements apply:

- a. The PS customer must provide a PG&E approved enclosure for PG&E's revenue-metering equipment. See Section 9 (Page 10) for detailed revenue-metering requirements.
- b. The PS customer must install primary protection at the POS. This protection may consist of a circuit breaker with phase and ground relays or, depending on the customer's load, fuses may suffice. If PG&E determines that fuses will not coordinate with PG&E's source-side protection, then the customer must use a circuit breaker. See Section 4 (Page 4) for circuit breaker and fuse requirements.
- c. The PS customer must install conduit from the POS to PG&E's box (if UG) or pole (if OH).
- d. PG&E will pull one continuous run of cable and connect to the customer's POS termination facility, not to exceed 500 feet (subject to an acceptable number of bends in the conduit).

2. OH Conductor

If the PS customer's primary line is overhead, then the first pole at the customer's property line is the POS. Refer to Figure A3-3. The following requirements apply:

- a. PG&E will install pole-top revenue-metering on the first pole on the PS customer's property. See Engineering Standard 058779 for pole-top revenue-metering requirements.

Technical Requirements for Electric Service Interconnection at Primary Distribution Voltages

- b. The PS customer must install primary protection on the second pole on their property, not to exceed 50 feet from the revenue metering pole. This protection may consist of a recloser or, depending on the customer's load, fuses may suffice. If PG&E determines that fuses will not coordinate with PG&E's source-side protection, then the customer must use a recloser. See Section 4 (Page 4) for recloser requirements.
- c. PG&E will interconnect its system with the customer's system at the revenue-metering pole.

2.2 Non-Preferred PS Arrangement Proposals

PS customers may propose a non-preferred PS arrangement. This typically occurs when the PS customer's primary distribution line is UG and the proposed location for the primary switchgear is greater than 500 feet from the property line. PG&E will consider such proposals, however, non-preferred service arrangement proposals may take longer to design, approve and can involve additional customer expense. Customers should contact PG&E early in the design process if they are considering a non-preferred PS arrangement.

A non-preferred PS arrangement may consist of: a) a splice box with an underground interrupter or subsurface fuse within 500 feet of the property line, or b) padmounted switchgear within 500 feet of the property line that includes a protective device such as a breaker or fuses. In these cases, the substructures and equipment are installed and owned by the customer. As with preferred arrangements, PG&E must approve the location, substructure/equipment arrangement and protective devices. In addition, note that the following requirements still apply:

1. The PS customer must provide space for PG&E's revenue-metering in their switchgear. See Section 10 (Page 12) for detailed metering requirements.
2. The PS customer must install conduit from the POS to PG&E's box (if UG) or pole (if OH).
3. PG&E will pull one continuous run of cable, not to exceed 500 feet, to the POS (subject to an acceptable number of bends in the conduit).

2.3 Location of Revenue-Metering

The preferred revenue meter location is at the POS. High-side metering is PG&E's preferred metering configuration. If PG&E approves low-side metering, a 2% adjustment factor will be applied at each stage of the transformation before the meter. See Section 9 (Page 10) for additional revenue-metering requirements.

2.4 Service Wire Configuration

If the PG&E point of service is at a protective device and not at the customer owned switchgear the wiring configuration, 3-wire or 4-wire, of the customer's service from the protective device to the switchgear must be the same as PG&E's.

Technical Requirements for Electric Service Interconnection at Primary Distribution Voltages

3 General Protection Requirements

It is important to minimize the potential hazard to life and property when interconnecting facilities to the PG&E distribution system. This requires the automatic detection of abnormal conditions and trouble related to a PS customer's equipment and the isolation of the condition and/or equipment within a reasonable time.

As a general rule, neither party should depend on the other for system protection. As such, PG&E's minimum protection requirements are designed and intended to protect the PG&E power system only. Moreover, the interconnection of a PS customer to the PG&E distribution system must not degrade existing PG&E protection and control schemes or interfere with the service of other customers (see Rule 2).

The PS customer's facilities must isolate any fault or abnormality that could adversely affect the PG&E electric system or the electric systems of other entities connected to the PG&E electric system.

PG&E assumes no liability for damage to the PS customer-owned facilities resulting from a lack of adequate coordination between the PS customer's protective device(s) and PG&E's protective devices, or negligence due to the PS customer's failure to maintain protective and/or isolation equipment.

PG&E recommends that the PS customer acquire the services of a qualified and licensed electrical engineer to review its plans. The PS customer must, at its expense, install, operate, and maintain system protection facilities in accordance with all applicable regulatory rules and requirements, and in accordance with this bulletin.

3.1 Data the PS Customer Provides to PG&E

1. The PS customer must provide the information necessary for PG&E to determine the interconnection requirements before PG&E approves the specific PS installation. This information includes, but is not limited to, the following:
 - a. Single-Line diagrams.
 - b. Meter and Relay diagrams.
 - c. Three-Line diagrams of required protective device.
 - d. Control diagrams including direct current (dc) tripping circuit.
 - e. Proposed relay specifications and settings.
 - f. Relay manufacturer, model, style, type, ranges, settings, and a copy of the relay instruction manual.

Technical Requirements for Electric Service Interconnection at Primary Distribution Voltages

- g. Projected electrical demand (i.e., kilowatt [kW]), including the following information:
 - (1) Power factor
 - (2) Load factor
 - (3) Large motor sizes
 - (4) Motor starting currents
 - (5) Customer's transformer size
 - (6) Estimated breakdown of the electric energy use (i.e., kilowatt hours [kwh]) by month
 - h. Full-size phase and ground coordination curves showing full coordination with PG&E's system.
 - i. A registered electrical engineer must prepare and stamp the fault–study results.
 - j. Maintenance program documentation for PG&E-required switches, interrupting devices, and protective equipment.
2. PG&E strongly recommends that the PS customer, or their representative, provide the above information before ordering equipment and finalizing the design.
 3. Also, before energizing the new PS facility, the PS customer must also provide a copy of the on-site test reports for the switches, devices, and relays at least **30** working days before energizing the service. This allows sufficient time for review, modification, and final PG&E approval. Qualified personnel must prepare these on-site test reports. Refer to Section “Equipment Test Requirements,” and Section “Pre-Energizing Test” for further details.

3.2 Data that PG&E Provides to the Applicant

PG&E provides the following engineering data to the PS customer:

1. System fault-duty at the property line.
2. Settings for PG&E source-side protective devices and the required clearance time to comply with PG&E protection standards.
3. Relay curves for PG&E source-side protective devices, if requested by the PS customer.

Technical Requirements for Electric Service Interconnection at Primary Distribution Voltages

4 Specific Protection Requirements

PG&E must review and approve the fault-interrupting devices that the PS customer selects. There are four basic types of fault-interrupting devices available for distribution systems:

- Circuit breakers
- Reclosers and Interrupters
- Fuses

The following sections provide specific requirements for each of these devices.

4.1 Circuit Breaker Requirements

The interconnecting circuit breaker must have sufficient capacity to interrupt the maximum available fault current at its location. Phase and ground relays approved by PG&E (see Table 1, PG&E Approved Relays, on Page 7) must be used to trip the circuit breaker for phase and ground faults. These relays must coordinate with PG&E's source-side protection. It must also include the following features:

1. Shunt-trip via a trip signal supplied through a battery external to the circuit breaker.
2. Lock out if operated by protective relays required for interconnection.
3. Capacitive tripping is unacceptable.
4. Relay Requirements
 - a. PG&E requires PS customers to install phase and ground over-current relays that trip the interrupting device at the POS. These relays must detect all phase and ground faults, and coordinate with PG&E's source side protection. All required relays must include relay targets, and have "manual reset" capability.
 - b. The PS customer must either: a) select phase and ground relays approved by PG&E or, b) have an International Electric Testing Association certified testing company test the relay as outlined in Attachment and provide the test results to PG&E for approval.
 - c. PG&E strongly recommends that PS customers submit all relay specification and setting proposals for PG&E approval before finalizing the design and ordering equipment. PS customers not submitting this information risk delaying their projects.

Technical Requirements for Electric Service Interconnection at Primary Distribution Voltages

Table 1 PG&E Approved Relays

See Tables G2-4 and G2-5 located in the [Transmission Interconnection Handbook, Section G2, "Protection and Control Requirements."](#) These tables list all of the types of relays approved for the PG&E distribution and transmission systems.

NOTE

PG&E's approval of the relays does not indicate the quality or reliability of a product or service. No endorsements or warranties are implied.

5. Relay Redundancy Requirement

The PS customer's protection system must contain redundancy such that the failure of any one component will still allow the customer's system to isolate the PS facility from the PG&E system under a fault condition. Three single-phase over-current relays and a ground over-current relay, or two three-phase over-current relays and a ground over-current relay satisfy the redundancy requirement. PS facilities, using microprocessor-based relays as a multifunctional protective device, must have backup relays.

6. Power Supply Requirements

Power supplies for PG&E-required relays and the tripping circuitry for the fault-interrupting device must be supplied from a battery and charger system. The system must include a dc under-voltage detection and alarm feature. Fuses are not allowed in the dc trip circuitry (dc breakers are acceptable).

The preferred battery type is flooded lead-acid (calcium, antimony) or nickel-cadmium (NiCd). Sealed batteries (Valve Regulated Lead Acid [VRLA]) are allowed if they meet PG&E requirements. An uninterruptible power supply (UPS) is unacceptable. See Section 11, "Battery Requirements for Interconnecting to the PG&E System," on Page 18, for more details on PG&E's battery requirements.

4.2 Reclosers and Interrupters

Contact PG&E for approved reclosers and interrupters.

4.3 Fuse Requirements

1. Fuses are single-phase, direct-acting, sacrificial links that melt to interrupt fault current and protect the equipment.

Technical Requirements for Electric Service Interconnection at Primary Distribution Voltages

2. PG&E may approve the use of fuses as the fault interrupting device at the POS for load-only facilities (i.e., no generation is interconnected), if the fuses coordinate with the PG&E source-side devices for both phase and ground faults. Large primary fuses that do not coordinate with PG&E's source-side protective phase and ground relays are not allowed. These fuses may cause other customers on the circuit to lose power due to a fault inside the PS customer's facility.
3. The PS customer must replace the blown fuses manually after each fault before the facility can return to service. Only trained, qualified personnel should replace the primary fuses.
4. If PG&E approves the fuses, the PS customer should consider installing a negative-sequence relay and/or other devices to protect its facility against single-phase conditions (however, this is not a requirement). The PS customer is responsible for protecting their equipment against single phase conditions, if they determine or feel that it is needed.
5. Customers must keep a full set of replacement fuses (PG&E must approve the size and type) onsite.

5 Equipment Test Requirements

The tests in this section apply only to the PG&E-required equipment at the POS; specifically, the breaker, the relays, and the tripping circuitry.

The customer must complete the following requirements:

- The equipment must pass all the tests described below.
- The customer must submit two copies of the test reports to PG&E a minimum of 30 working days before energizing the PS facilities.
- Each test report must identify the equipment tested and that identification must match that in the single-line or three-line diagrams.

The customer must meet the above requirements and obtain PG&E approval of the test reports at least ten working days before PG&E energizes the PS. PG&E strongly recommends that the PS customer coordinate the test program with PG&E.

5.1 Circuit Breaker Tests

The PS customer must perform the following circuit breaker tests:

1. Minimum-to-trip test at 70% or less of the nominal control voltage on all circuit breakers operated by PG&E-required relays.
2. Micro-ohm test on the main circuit breaker(s) at the POS.

Technical Requirements for Electric Service Interconnection at Primary Distribution Voltages

3. Timing test showing the time from the trip initiation to the opening of the main poles. Proving insulation tests, as described below.
4. Proving Insulation

A 1,000 or 2,500 volt (V) dc megger test, or a 1,000 V high-pot test is acceptable for the insulation tests described below.

- a. Megger circuit breaker(s) at the POS operated by PG&E require relays (see Table 2 below).

Table 2. Circuit Breaker Positions and Connections

Circuit Breaker Position	Connection
Circuit breaker open.	Each pole to ground, pole 1 to 2, pole 3 to 4, pole 5 to 6
Circuit breaker closed.	Pole 1–ground, pole 3–ground, pole 5–ground
If the poles are in a common tank or cell.	Pole 1 to 3, pole 3 to 5, pole 5 to 1

- b. Megger (phase-to-phase and phase-to-ground) all buses from the POS to the main breaker or fuses.
- c. The main circuit breaker(s) must have a dielectric test performed on the insulating medium (gas or oil). This test is not required for factory-sealed, circuit-switcher interrupters.

5.2 Tests for Current Transformers and Current Circuits

PS customers must perform the following tests for current transformers (CTs) and current circuits associated with PG&E-required relays:

1. Check the saturation on all CTs. If this is not possible, a manufacturer’s curve is acceptable.
2. Prove the ratio of all CTs by using current (primary to secondary) or voltage (secondary to primary).
3. Check the CTs for the proper polarity.
4. Check the CT circuits for the proper connections.
5. Check the continuity of the CTs by:
 - a. Applying primary or secondary current at the CT block.

Technical Requirements for Electric Service Interconnection at Primary Distribution Voltages

- b. Verifying that the proper current exists in each phase relay and the ground relay.

Customers must perform each test (primary or secondary) in all combinations prove that all phase relays and ground relays have proper connections.

PS customers must also ensure that no loose wiring or parallel current paths exist, by applying or injecting the current to achieve a secondary reading of 5 amperes (A) in each relay.

Check each phase of each current circuit feeding PG&E–required relays. Megger the total circuit with the ground wire lifted (to prove that only one ground exists).

5.3 Relay and Fuse Tests

The testing requirements for relays/fuses include:

1. PS customers must field test the settings of PG&E-required relays to verify the following items:
 - a. The minimum operating point at which the relay picks up (minimum pickup).
 - b. Time delays at three different current-test points, in integral multiples of the minimum pickup that closely characterize the relay time-current curve.
 - c. Test results must be within the tolerances listed below:
 - (1) Current/Voltage/Time $\pm 10\%$
 - (2) Impedance/Phase Angle $\pm 0.05\%$
 - (3) Frequency $\pm 0.05\text{ Hz}$
2. Check all fuses for continuity before energizing.

5.4 Tests Recommended (But Not Required by PG&E) for the PS Customers

1. Transformer

It is recommend (but not required by PG&E) that the customer perform the following tests to prove the insulation and turns ratio on their primary service transformers.

a. Proving Insulation

A 1,000 or 2,500 volt (V) dc megger test or a 1,000 V, high-pot test is recommended for any of the insulation tests below.

- (1) Megger the main transformer(s) winding-to-winding and each winding-to-ground.

Technical Requirements for Electric Service Interconnection at Primary Distribution Voltages

- (2) Megger the buses (phase-to-phase and phase-to-ground) from the POS to the main transformer.
 - (3) Perform a dielectric test on the main transformer(s) insulating medium (gas or oil).
- b. Proving Ratios
- Prove the main transformer(s) ratio(s) using one of the following methods:
- (1) Turns-ratio tester.
 - (2) Voltage-ratio test on the final operating tap. Consult with PG&E to best match the present distribution-system voltage.

6 Pre-Energizing Test

6.1 Customers must meet the following requirements before PG&E will energize the PS:

1. Ensure that any inspections required by local governmental and regulatory agencies are complete and any applicable permits are obtained before PG&E energizes the PS.
2. A PG&E technical representative must witness trip checks of all PG&E-required relays. This may require injecting a signal to trigger the relay. This proves that the relay will handle the trip current of the circuit breaker. It also proves relay targeting. Jumpering the studs on the back of the relay is not acceptable.
 - a. The Primary Service Entity shall provide all test equipment and qualified 3rd party personnel to perform the required tests. PG&E recommends third party testers to be National Electrical Testing Association (NETA) certified. PG&E shall be there strictly as an observer. Form PS-1 shall be completed by the PG&E representative on site at the time of the pre-energizing test.
3. A PG&E technical representative must verify grounds are bonded per standard (switching platforms, fences, buildings, etc.) and verify signage is correct per the below requirement. All signs shall be constructed to be weather proof.
 - a. Disconnect -- The disconnect sign shall have 1 inch wide by 2 inch high, with colors venetian red (#3) lettering on a buff (#1) background (or similar). It shall be attached as shown on Engineering Design Standard 454092 (see Appendix D). If the facility has multiple feeds with multiple separate disconnect switches, then each disconnect requires a separate sign.

Technical Requirements for Electric Service Interconnection at Primary Distribution Voltages

- b. Location -- The location sign shall have 1 inch high venetian red (#3) lettering on a buff (#1) background. PG&E's standard location sign size is 14 inches wide by 7 inches high overall. It shall be posted at each entrance to the facility. If there are other gates or doors to go through, then each one of those shall have a sign as well. For example: One posted at the entrance to the primary service facility and one posted on the entrance to the substation within the primary service facility.
4. After energizing the PS and adding load, a PG&E technical representative must witness the reading of the load current in each phase relay and the absence of load current in the ground relay. The PG&E technical representative will then seal the relays.
5. The PS customer is responsible for providing all test equipment, and qualified personnel to conduct the tests in the presence of a PG&E technical representative.

7 General Notes

- The PG&E system has an A-C-B counterclockwise rotation.
- Before making changes to PG&E-required protection equipment, the customer must submit the proposed changes to PG&E for review and approval.
- The customer is responsible for maintaining PG&E-required protection equipment in accordance with PG&E maintenance and test practices. After completing such tests, the customer must submit maintenance and test report documentation to PG&E for review and approval. A PG&E technical representative will reseal PG&E-required relays following setting changes and routine maintenance.
- Contact the local PG&E representative with any questions.

8 Alternate Source

- 8.1 A PS customer may request an alternate primary voltage source installed at customer expense. Requests for an alternate source are handled on a case-by-case basis. This section describes some of the technical requirements associated with installing and operating a PS with an alternate source. Technical requirements may change depending on location and a variety of other factors. PG&E strongly recommends that customers contact the Company early in the design phase to ensure a successful project. The PS customer and PG&E must work together to ensure that an alternate source system fulfills the customer's needs while not degrading PG&E protection schemes, operating flexibility or cause interference with another customer's service.
- 8.2 When a PS load is transferred from the primary source to the alternate source or vice versa, a momentary outage ("drop-and-pickup" operation) occurs.

Technical Requirements for Electric Service Interconnection at Primary Distribution Voltages

- 8.3 When the PS is fed from the alternate source and the PS customer wants to transfer back to the primary source with a parallel operation (“make-before-break” method), the PS customer must meet the following requirements:
1. The ratios and electrical connections of the transformers on both sources must be well matched to minimize circulating currents.
 2. The impedance of the transformers and the relative phase angles of the sources must be such that any “through load” (i.e., flowing of power through the PS customer’s electrical system to other customers) does not cause overloads.
 3. The parallel transfer operation must not degrade protection, inhibit PG&E’s operating flexibility, or overstress equipment (customer or PG&E equipment).
 4. The transfer switches, one on each side of the PS load, require an automatic interlock control scheme to minimize the time the two systems are paralleled. The transfer switches must be circuit breakers or other suitably rated, automatically controlled switches.

NOTE

The parallel period must be less than one second because the presence of two parallel circuits will increase the fault duty and may overstress the PS customer’s equipment.

5. In some cases, PG&E may require additional protective devices and/or special operating procedures to ensure safe and reliable service for the PS customer and other PG&E customers.
6. Each parallel transfer operation can only proceed after PG&E’s specific approval. The PS customer must obtain PG&E’s approval before performing the parallel transfer operation. PG&E may withhold approval if, in its sole judgment, the above requirements have not been met, or if a previously unforeseen factor or change in conditions is deemed to jeopardize the operator, public safety, or reliability to customers.
7. The PS customer must assume all liability for any problems or damage resulting from any parallel transfer operation.

9 Revenue-metering Requirements

This section addresses direct access (DA) and bundled–service PS customers connected at distribution voltages (34.5 kV and below), as described in Rule 2. Customers must satisfy PG&E’s revenue–metering requirements and those of other applicable governing authorities (i.e., California Public Utilities Commission [CPUC], California Independent System Operator [CAISO], etc.).

For customers exporting power, loads connected at distribution voltages must satisfy the metering protocols established by PG&E and CAISO. Exceptions are handled on a case-by–

Technical Requirements for Electric Service Interconnection at Primary Distribution Voltages

case basis with approval from PG&E's Customer Metering Services in close coordination with Field Metering Services.

Other arrangements that affect the required metering installation may also require a "Generation Special Facilities Agreement."

There are two types of distribution services:

- Wholesale
- Retail (i.e., end-users)

9.1 Wholesale Service

1. For wholesale-service interconnections, the PS customers must provide, install, own, and maintain all revenue-metering-related equipment, including all the items provided and maintained by PG&E or a Meter Service Provider (MSP) listed under "Retail Service" below.
2. PS customers requesting wholesale service must meet the following criteria:
 - a. CAISO metering standards
 - b. CPUC-approved metering standards
 - c. PG&E's requirements
 - d. Enter into a Meter Service Agreement (MSA) with the CAISO and, in certain cases, with PG&E. The MSA specifies requirements regarding the retrieval of load data and accessibility by CAISO.
3. The wholesale PS customer is responsible for ensuring that the meters comply with CAISO's meter standards and accuracy requirements.
4. All PS customers must contact PG&E's local account services representative for PG&E's revenue-metering requirements.

9.2 Retail Service (End Users)

Electric Rule 22 "[Direct Access](http://www.pge.com/tariffs/tm2/pdf/ELEC_RULES_22.pdf)" governs the interconnection and operating requirements for DA customers. Please use the following link to access the document, http://www.pge.com/tariffs/tm2/pdf/ELEC_RULES_22.pdf.

1. Customer Service Elections

According to Rule 22, customers have the opportunity to acquire their electric power needs under the following two options:

- a. Bundled Utility Services – traditional service from PG&E

Technical Requirements for Electric Service Interconnection at Primary Distribution Voltages

(1) Bundled Services

For bundled (full-service) utility services, PG&E, in most cases, continues to provide the following services:

- Own, provide, and maintain metering equipment, including the meter
- Meter reading

Customers returning to bundled service may own the meter, if the meter is supported by PG&E. In the event that the customer's meter becomes nonfunctional, PG&E will replace the meter with an equivalent meter and return the former meter to the customer (end-user).

- b. DA – customers purchase energy from various suppliers and related services from Energy Service Providers (ESPs)

2. Customer Meter Options

Customer metering options include:

- a. DA customers, PG&E, or the ESP may own the hourly meter.
- b. The ESP may act as its own MSP or hire an MSP to maintain metering equipment compliance.
- c. The ESP may also act as its own Meter Data Management Agent (MDMA) or hire an MDMA to read the meter and maintain the meter data.
- d. Contracting with PG&E to perform metering services or meter-data management.
- e. PG&E retains the right to physically access any hourly or monthly meter data.
- f. PG&E continues to read, test, and inspect the meters on PG&E's system.

3. PG&E Is The MSP

PG&E, as the MSP, continues to provide, install, maintain, and test the following:

- a. Revenue-metering instrument transformers (voltage transformers and current transformers), which are considered part of the distribution system per CPUC decision D.97-10-087, dated October 30, 1997. PG&E Engineering Document 058779, "Pole Top Primary Metering Installation, Cluster Mounted (12 or 21 kV Line)," shows a typical, distribution, pole-type metering.

Technical Requirements for Electric Service Interconnection at Primary Distribution Voltages

- b. Secondary wiring from the base of the metering transformers to the revenue meter in a customer-supplied dedicated raceway (conduits) used solely for revenue-metering.
 - c. Meters and associated metering devices such as isolation relays, test switches, etc.
4. PG&E Is the MDMA
PG&E, as the MDMA, continues to provide the following services:
 - a. Reading raw meter data from the interval meter.
 - b. Validating, editing, and estimating the data of a settlement-quality form.
 - c. Placing the settlement-quality data on the MDMA server and, if necessary, performing a usage adjustment.

5. Customer Responsibilities

The customer (end-user) maintains the following:

a. The Meter Enclosure

To maintain the required metering accuracy, the distance between the meter enclosure and the revenue-metering transformers must not exceed 50 feet.

PG&E must approve any variance from this general rule. The enclosure must be grounded and located within the substation ground grid. Access must be readily available for PG&E employees to read and maintain the metering equipment.

The enclosure must be equipped with the following items:

- (1) Auxiliary 120 V duplex plug
- (2) Overhead light
- (3) Light switch adjacent to the door
- (4) Ground bus connected to the ground and mounted near the bottom of the wall where the meters are located

Please refer to PG&E's [Electric and Gas Services Requirements \(Greenbook\)](#) and [Engineering Document 058779, "Pole Top Primary Metering Installation, Cluster Mounted \(12 or 21 kV Line\)."](#)

Technical Requirements for Electric Service Interconnection at Primary Distribution Voltages

b. PG&E-Approved Meter Panels

Please refer to PG&E's [Electric and Gas Services Requirements](http://www.pge.com/greenbook) (<http://www.pge.com/greenbook>)

c. The Pull Lines

The customer must install a pull line in the conduit between the metering enclosure and the junction box at the base of the metering-unit support structure to facilitate the MSP's installation of the metering-unit secondary wires.

Only install the MSP's secondary revenue metering wires in the conduit between the meter enclosure and the PT/CT units. Conduits may be metallic or nonmetallic.

d. Telephone Lines into the Metering Enclosure

If a telephone line is required to read the meter, the customer may be responsible for installing the line into the metering enclosure and establishing telephone service. If a land-line is unavailable and cellular signal levels are acceptable, the use of a cellular telephone is acceptable.

If the meter's telephone line is not dedicated to the meter, the customer, with prior approval from PG&E's local metering group, may arrange to use a line-sharing switch.

The customer must ensure that the telephone line terminations in switchboards, panels, pole-mounted meters, and pedestals meet the following requirements:

- (1) Located within five circuit-feet of the centerline of the meter.
- (2) Located between a minimum of 18 inches and a maximum of 72 inches above the finished grade.

When cellular telephones are used, the same location requirements apply to the power supply, as measured from the load side of the meter. Locate the power supply outside PG&E's sealable section.

10 Communication Circuits

PG&E may require communications circuits between PG&E and the customer's PS facilities for the following purposes:

- Protection
- Revenue Metering

Technical Requirements for Electric Service Interconnection at Primary Distribution Voltages

- Energy Management System (EMS)
- Supervisory Control and Data Acquisition (SCADA)
- Generation
- Voice communications

When external communication circuits are installed, the responsible party must ensure that the high-voltage protection (HVP) equipment on these circuits meets all applicable standards.

11 Battery Requirements for Interconnecting to the PG&E System

- 11.1 This section describes PG&E's process for ensuring safety and reliability of for customers who connect to Company systems. The recommendations made here will ensure that the system operates as designed.
- 11.2 Because of serious reliability, safety and reduced life concerns with sealed (also called Valve Regulated Lead Acid [VRLA]) batteries industry wide, PG&E has decided to completely stop the use of sealed batteries in our Substation or any switchgear installations or interconnection using these batteries. Flooded lead acid (calcium, antimony) and Nickel-Cadmium (NiCd) are the only batteries acceptable in these installations. Switchgear compartments typically see very high temperatures, and if sealed batteries are used they will dry out in less than a few years causing safety and reliability concerns along with not having the capability to trip breakers.

Refer to the side by side comparison of IEEE Standard 450-2002 Section 5.2.3 (IEEE Recommended Practice for Maintenance, Testing and Replacement of Vented lead acid batteries for Stationary applications –also referred as Flooded batteries) and IEEE Standard 1188-1996 Section 5.2.2 Subsections a, b & c.

- 11.3 IEEE Recommended Practice for Maintenance, Testing and Replacement of Valve-regulated batteries for Stationary application. Also referred as VRLA) clearly demonstrates that VRLA requires Quarterly ohmic resistance testing compare to yearly ohmic testing for flooded batteries. Experience industry wide indicates problem with doing ohmic tests on VRLA because of the design of battery and trying to make connections to the terminals and interconnecting hardware. Even if ohmic resistance reading is not done on flooded battery, the failure modes can be detected by other means whereas with VRLA eliminating this test could cause dryout condition and ultimately catastrophic failure. In hot environment VRLA would require charger compensation as well as monitoring which is expensive and still not proven to be adequate. In the telecommunication industry there are presently trials under way for system wide replacements of VRLA with Flooded or NiCd batteries. PG&E recommends use of NiCd batteries in switchgear cubicle because of better performance under extreme temperatures. Flooded batteries can also be used in switchgear.

Technical Requirements for Electric Service Interconnection at Primary Distribution Voltages

- 11.4 Additional reasoning for not using VRLA in substation as pointed out by IEEE Battery working group Chairman in the recent paper published in IEEE. "Summarizing the issue for VRLA batteries, there is a considerable risk involved in installing a single VRLA string in a substation. If parallel strings are installed, to operate reliably, they must be redundant, either by design or by a sufficient degree of conservatism in the sizing calculation. In building in redundancy, however, the main aim of reducing battery costs is compromised. Despite the early claims of maintenance-free operation, VRLA batteries require considerable surveillance and testing to maintain a high degree of reliability, IEEE 1188-1996 [2] recommends quarterly internal ohmic measurements and annual discharge testing of VRLA. These measures are largely ignored by the telephone operating companies because of their low loads and use of parallel strings, as detailed above. In substation operation, however, these practices are doubly important because of the higher currents involved".
- 11.5 It is required for the third party customer to provide the following documentation to PG&E for review and acceptance by the Substation Engineering Department:
1. Type of Battery (Vented Lead Acid-VLA or NiCd). Monoblock (multiples cells in a jar) batteries from C & D, EnerSys or other vendors will be acceptable. Battery rack must be designed to withstand loading based on zone 4 or IEEE 693 (High Seismic).
 2. Detail information of load including continuous and momentary. No minimum load requirement- Smallest flooded acid may be the limitation
 3. Battery sizing calculation based on IEEE Standard 485-2010 (IEEE recommended Practice for Sizing Large Lead Storage Batteries for Generating Stations and Substations) or IEEE Standard 1115-2014 (IEEE recommended Practice for Sizing Nickel-Cadmium Batteries for Stationary application) and minimum 8 hours discharge rate using manufacturer software (to ensure proper discharge curve is used) using aging factor of 1.25 and design margin of 1.1 to be clearly shown on the calculation. Charger sizing calculation based on battery size with recharge time of 12 hours assuming charger will support the continuous load as well as recharges the battery at the same time.
 4. When battery is installed proof of three (3) hour discharge testing to ensure battery has the capacity to support the load and trip; per IEEE Standard 450-2010 (Voltage measurements should be taken every 15 minutes throughout the testing).
 5. Documentation showing what kind of maintenance will be done (Monthly, Quarterly, and Yearly etc).
 6. Monitoring of minimum battery low voltage by separate voltage relay or through charger and provide critical alarm to scada or monitoring system.
 7. Along with documentation of items 1-5; See Attachment 1, Third Party Interconnection Battery Information Sheet And Acceptance Document, located on pages 23 and 24. This information must be completed and submitted by the customer to Substation Project Engineering Department for approval.

Technical Requirements for Electric Service Interconnection at Primary Distribution Voltages

12 Preferred Service Arrangement Figures

The following pages provide figures showing the preferred service arrangements for overhead and underground primary services.

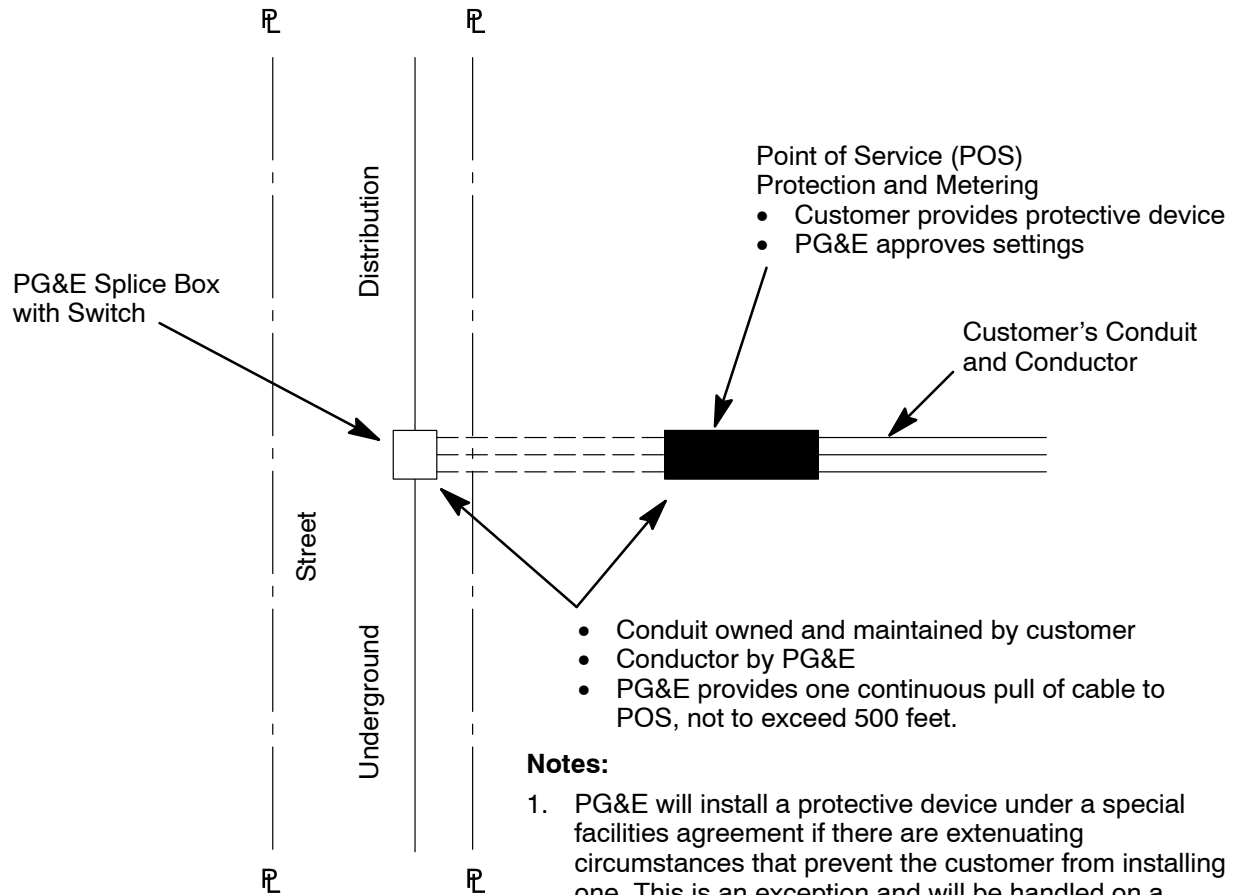

Notes:

1. PG&E will install a protective device under a special facilities agreement if there are extenuating circumstances that prevent the customer from installing one. This is an exception and will be handled on a case-by-case basis
2. If PG&E's primary facilities are across the street, PG&E will own and maintain substructures in the franchise area and the customer will own and maintain substructures on private property. PG&E will still provide one continuous pull of cable to POS, not to exceed 500 feet.

Figure A3-1
Underground Primary Service from Underground Distribution
Preferred Service Arrangement
POS ≤ 500 Feet From PG&E Splice Box

Technical Requirements for Electric Service Interconnection at Primary Distribution Voltages

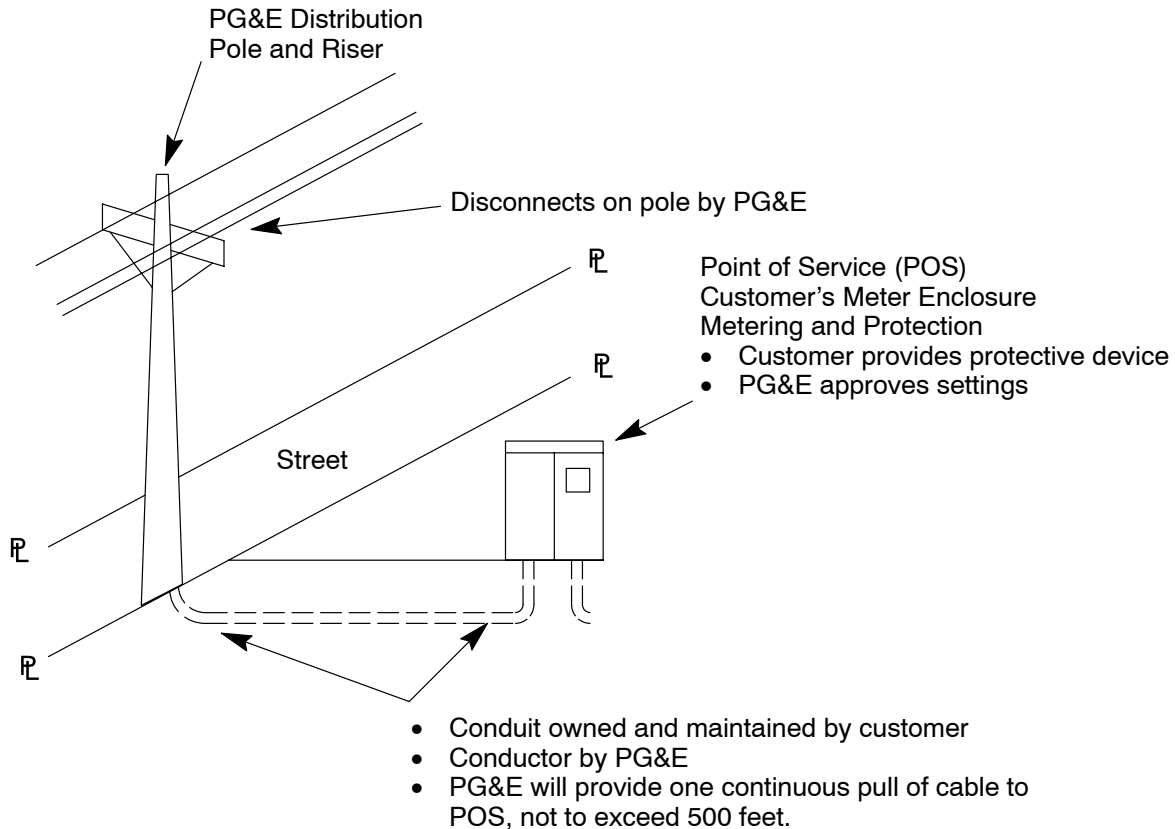

Notes:

1. PG&E will install a protective device under a special facilities agreement if there are extenuating circumstances that prevent the customer from installing one. This is an exception and will be handled on a case-by-case basis
2. If PG&E's primary facilities are across the street, PG&E will own and maintain substructures in the franchise area and the customer will own and maintain substructures on private property. PG&E will still provide one continuous pull of cable to POS, not to exceed 500 feet.

Figure A3-2
Underground Primary Service from Overhead Distribution
Preferred Service Arrangement
POS ≤ 500 Feet From PG&E Pole

Technical Requirements for Electric Service Interconnection at Primary Distribution Voltages

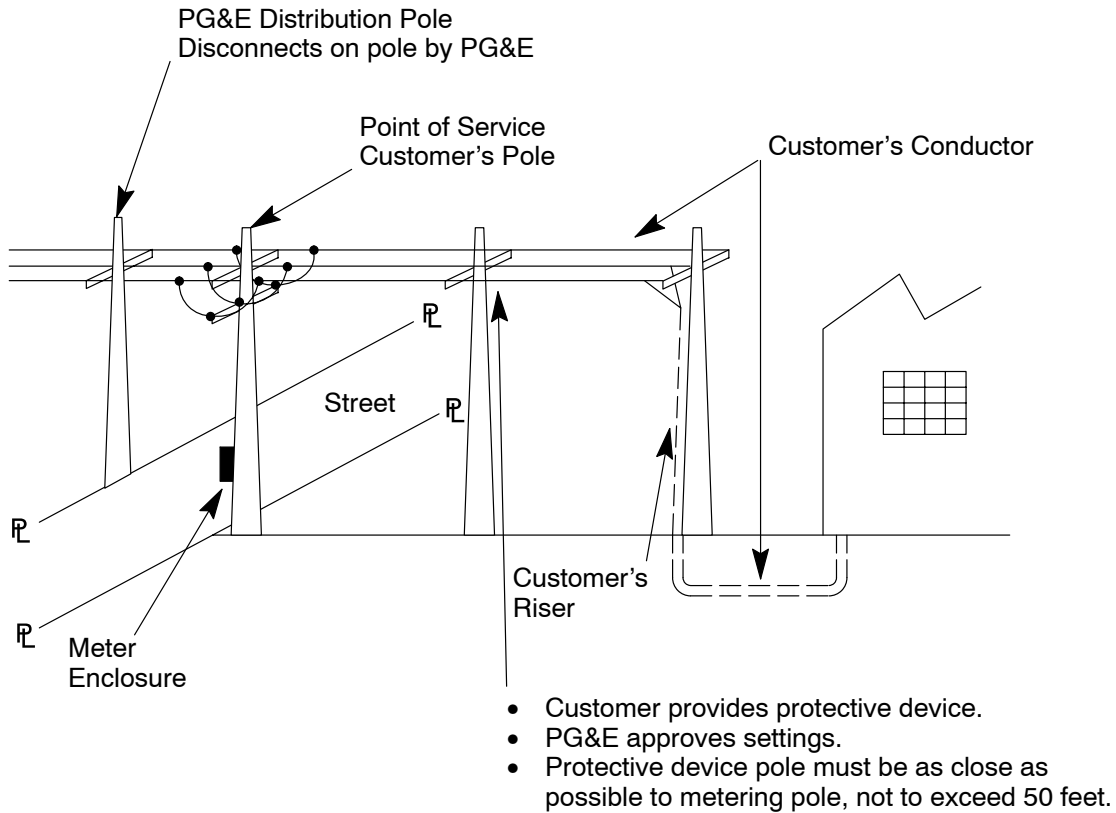

Note:

PG&E will install a protective device under a special facilities agreement if there are extenuating circumstances that prevent the customer from installing one. This is an exception and will be handled on a case-by-case basis.

**Figure A3-3
 Overhead Primary Service from Overhead Distribution
 Preferred Service Arrangement**

Technical Requirements for Electric Service Interconnection at Primary Distribution Voltages

Attachment 1, Third Party Interconnection Battery Information Sheet And Acceptance Document

Section 1: To be completed by Customer while providing all pertinent information and documentation for review based on Appendix T of the TIH or PG&E document TD-2999B.

Project Name: _____ **Site:** _____

Type of Interconnection/project: _____ **Date:** _____

(Transmission, Distribution, Primary Service, Relay Replacement, etc.)

1A) - Battery

Is Battery Flooded type or Sealed Type	
Battery Manufacturer	
Battery Size.	
Battery Model No.	

1B) Charger

Charger Size	
Charger Model No.	

1C) Rack

Is Rack Certified for IEEE 693, High Seismic Zone (UBC Certification is not accepted) –	
Rack Manufacturer and Model No.	

2- List of DC Loads

Is list and quantity of DC Loads included with the Submittal?	
---	--

3-Battery Sizing Calculation

Is Battery sizing sheet based on IEEE 485-1997 or IEEE 1115-2000 included with the Submittal.	
---	--

4 –Proof of Discharge Testing

Is proof of Discharge Testing included with this Submittal	
--	--

5 –Maintenance

Are maintenance schedule and procedure included with this Submittal	
---	--

6 – Battery Low Voltage Monitoring

Are details included with this submittal for 24/7 monitoring of Low DC Voltage. – Please specify Yes or No Remote monitoring is required for unmanned Sites	
--	--

Technical Requirements for Electric Service Interconnection at Primary Distribution Voltages

Section 2: To be completed by PG&E Substation Engineering Department

Third Party Interconnection Battery Acceptance Document

Date: __/__/____

Name of Customer:

JO#:

Distribution engineer or PM:

Reviewed by:

Item 1: Type of Utility Grade Battery –

Battery Type:

Rack Type:

Charger Type:

Item 2. Detailed Load Information –

Item 3. Battery & Charger Sizing Calculations –

Item 4. Proof of 3hr-Discharge Testing –

Item 5. Maintenance Procedures –

Item 6. Monitoring of Minimum Battery Voltage –

(Ensure battery DC low voltage is monitored as this will be verified during the Pre-Parallel inspection).

Thank you,

(Engineer who reviewed Info)

Substation Project Engineering

Technical Requirements for Electric Service Interconnection at Primary Distribution Voltages

DOCUMENT APPROVER

Connie Pascua Taylor, Supervising Standards Engineer, Electric Distribution Standards

Roozbeh Movafagh, Senior Manager, Distribution Standards Engineering

DOCUMENT CONTACT

Daniel Jantz, Engineering Standards Technical Specialist Expert, Electric Distribution Standards

INCLUSION PLAN

There is no set inclusion plan at this time for this bulletin.

REVISION NOTES

Where?	What Changed?
What you need to know	<ul style="list-style-type: none"> • Added new note 7 in section 11.5 requiring customers to complete and submit the battery information in Attachment 1. • Added Attachment 1.

