



Installation Instructions & Owner's Manual

Evolve Series®

Twin Water Softeners and Conditioners



For Models:

- EV1-TW
- EV2-TW
- EVR-TW
- EVRC-TW
- EVRS-TW
- EVRCS-TW

TABLE OF CONTENTS

Preinstallation Instructions for Dealers	3
Bypass Valve	4
Installation	5
Programming Procedures	8
Start-up Instructions	10
Operating Displays and Instructions	11
Troubleshooting Guide	13
Replacement Parts	20
Installation Fitting Assemblies	28
Specifications	31
Warranty	33
Quick Reference Guide	34

YOUR WATER TEST

Hardness _____ gpg
 Iron _____ ppm
 pH _____ number
 *Nitrates _____ ppm
 Manganese _____ ppm
 Sulphur _____ yes/no
 Total Dissolved Solids _____

*Over 10 ppm may be harmful for human consumption.
 Water conditioners do not remove nitrates or coliform bacteria,
 this requires specialized equipment.

Look for our
 Evolve
 instructional
 videos on



PRODUCT INFORMATION

Installing Dealer must fill out this information prior to unit installation

MODEL NUMBER _____

SERIAL NUMBER _____

DEALER INFORMATION:

Your Evolve Series twin water softeners and conditioners are precision built, high quality products. These units will deliver conditioned water for many years to come when installed and operated properly. Please study this manual carefully and understand the cautions and notes before installing. This manual should be kept for future reference. If you have any questions regarding your water conditioner, contact your local dealer.

PRE-INSTALLATION INSTRUCTIONS

The manufacturer has preset the water treatment unit's sequence of cycles, cycle times, salt dose, exchange capacity and salt dose refill time.

THE DEALER SHOULD...

- Read this page and guide the installer regarding hardness, day override, time of regeneration, service alarm, and buzzer alarm settings prior to installation.

THE INSTALLER SHOULD...

- Program installer settings including hardness, day override, time of regeneration, service alarms, and buzzer alarm.
- Read Operating Displays and Maintenance section.
- Set the time of day
- Read Power Loss and Error Display section.
- Ensure that system and installation are in compliance with all state and local laws and regulations

THE HOMEOWNER SHOULD...

- Read Programming Procedures section.
- Read Operating Displays and Maintenance section.

GENERAL OPERATING DISPLAYS & NAVIGATION

During normal operation, the default user displays are "time of day" and "gallons per minute". Flow rate, vacation mode, capacity remaining, and days to a regeneration are optional displays. For more explanation, consult the "operating displays and maintenance section". Pressing the **NEXT** button on a general operating screen will cycle through the available operating displays.

In any screen other than a general operating display, the **NEXT** button will proceed to the next step, the **REGEN** button will return to a previous step, and the **CLOCK** button will return to the general operating displays. Any changes made prior to the exit will be incorporated. If no buttons are pressed within five minutes, the display will return to the general operating displays.

DOUBLE REGENERATION

Two generations within 24 hours are possible with a return to the preset program. To initiate a double regeneration:

1. Press the **REGEN** button once. "REGEN TODAY" will flash on the display.
2. Press and hold the **REGEN** button for three seconds until a regeneration begins.

Once the valve has completed the immediate regeneration, the valve will regenerate once more during the preset time.

BYPASS VALVE

The bypass valve is typically used to isolate the control valve from the plumbing system's water pressure in order to perform control valve repairs or maintenance. The 1" full flow bypass valve incorporates four positions, including a diagnostic position that allows a service technician to have pressure to test a system while providing untreated bypass water to the building. Be sure to install bypass valve onto main control valve before beginning plumbing or make provisions in the plumbing system for a bypass. The bypass body and rotors are glass-filled Noryl® and the nuts and caps are glass-filled polypropylene. All seals are self-lubricating EPDM to help prevent valve seizing after long periods of non-use. Internal "O" Rings can easily be replaced if service is required.

The bypass consists of two interchangeable plug valves that are operated independently by red arrow shaped handles. The handles identify the direction of flow. The plug valves enable the bypass valve to operate in four positions.

- 1. NORMAL OPERATION POSITION:** The inlet and outlet handles point in the direction of flow indicated by the engraved arrows on the control valve. Water flows through the control valve for normal operation of a water softener or filter. During the regeneration cycle this position provides regeneration water to the unit, while also providing untreated water to the distribution system (**Fig. 1**).
- 2. BYPASS POSITION:** The inlet and outlet handles point to the center of the bypass. The system is isolated from the water pressure in the plumbing system. Untreated water is supplied to the building (**Fig. 2**).
- 3. DIAGNOSTIC POSITION:** The inlet handle points toward the control valve and the outlet handle points to the center of bypass valve. Untreated supply water is allowed to flow to the system and to the building, while not allowing water to exit from the system to the building (**Fig. 3**). This allows the service technician to test the unit and perform other functions without disrupting the water going to the building.

NOTE: The system must be rinsed before returning the bypass valve to the normal position.

- 4. SHUT OFF POSITION:** The inlet handle points to the center of the bypass valve and the outlet handle points away from the control valve. The water is shut off to the building. The water treatment system will depressurize upon opening a tap in the building. A negative pressure in the building combined with the unit being in regeneration could cause a siphoning to the building. If water is available on the outlet side of the unit, it is an indication of water bypassing the system (**Fig. 4**) (i.e. a plumbing cross-connection somewhere in the building).

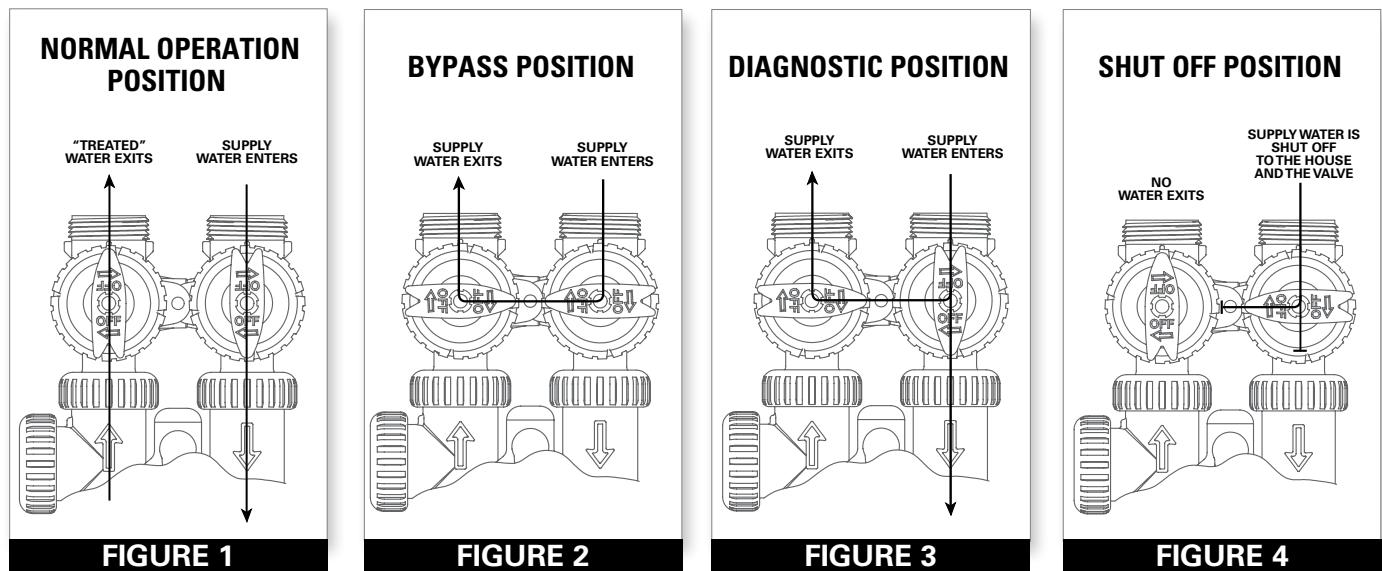

INSTALLATION

GENERAL INSTALLATION & SERVICE WARNINGS

The control valve, fittings and/or bypass are designed to accommodate minor plumbing misalignments. There is a small amount of “give” to properly connect the piping, but the water treatment unit is not designed to support the weight of the plumbing.

Do not use Vaseline, oils, other hydrocarbon lubricants, or spray silicone anywhere. A silicone lubricant may be used on black “O” Rings, but is not necessary. **Avoid any type of lubricants, including silicone, on red or clear lip seals.**

Do not use pipe dope or other sealants on threads. Teflon® tape must be used on the threads of the 1” NPT inlet and outlet and on the threads for the drain line connection. Teflon® tape is not used on the nut connections or caps because “O” Ring seals are used. The nuts and caps are designed to be unscrewed or tightened by hand or with the special plastic Service Wrench, #CV3193-02. If necessary, pliers can be used to unscrew the nut or cap. Do not use a pipe wrench to tighten nuts or caps. **Do not place screwdriver in slots on caps and/or tap with a hammer.**

SITE REQUIREMENTS

- Water pressure – 30-100 psi
- Water temperature – 33-100°F (0.5-37.7°C)
- Electrical – 115/120V, 60Hz uninterrupted outlet
- Current draw is 0.5 amperes
- The plug-in transformer is for dry locations only

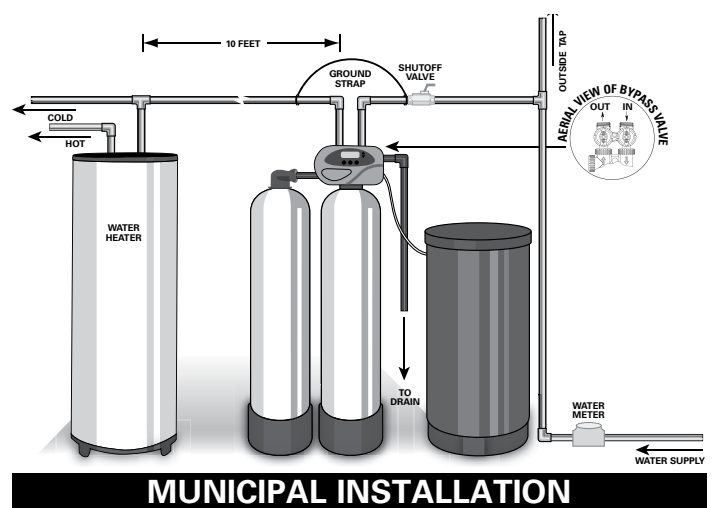
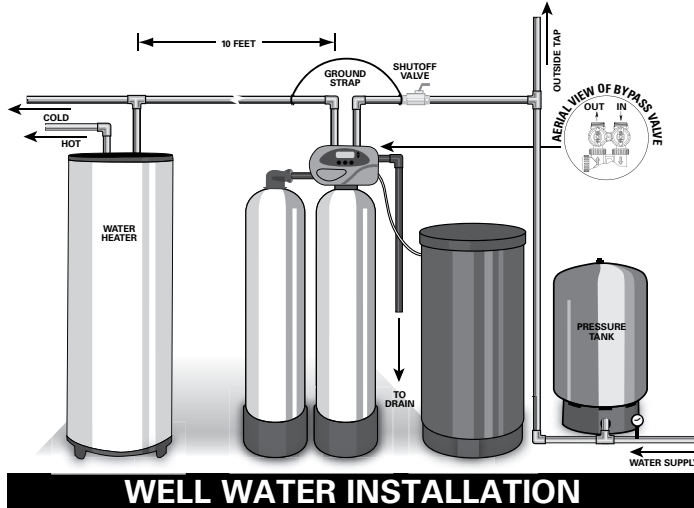

1. The distance between the drain and the water conditioner should be as short as possible (see #9).
2. Since salt must be added periodically to the brine tank, it should be in an easily accessible location.
3. The media tanks should be installed on a firm, level surface (above or below grade).
4. It is NOT recommended to install any water treatment unit with less than 10 feet of piping between its outlet and the inlet of a water heater.



CAUTION: To protect the unit in the event of a hot water heater backup, the manufacturer recommends the use of an expansion tank on the outlet side of the unit (see diagram).

5. Do not locate unit where it or its connections (including the drain and overflow lines) will ever be subjected to temperatures under 33°F.
6. Do not subject the tank to any vacuum as this may cause an “implosion” and could result in leaking. If there is a possibility a vacuum could occur, please make provision for a vacuum breaker in the installation.

7. **INLET/OUTLET PLUMBING:** Be sure to install Bypass Valve onto main control valve before beginning plumbing. (See installation picture to right. Be sure bypass is connected to treated water inlet and outlet.) If it is desired to bypass outside hydrants, a cold water kitchen sink, or other locations, provisions should be made at this time. Install an inlet shutoff valve and plumb to the unit’s bypass valve inlet located at the right front as you face the unit.

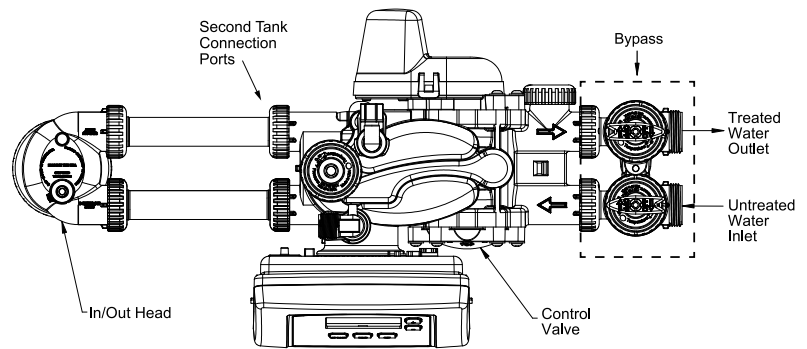

There are a variety of installation fittings available. They are listed under the Installation Fitting Assemblies section of the manual. When assembling the installation fitting package (inlet and outlet), connect the fitting to the plumbing system first and then attach the nut, split ring and “O” Ring. Heat from soldering or solvent cements may damage the nut, split ring or “O” Ring. Solder joints should be cool and solvent cements should be set before installing the nut, split ring and “O” Ring. Avoid getting solder flux, primer, and solvent cement on any part of the “O” Rings, split rings, bypass valve or control valve. If the building’s electrical system is grounded to the plumbing, install a copper grounding strap from the inlet to the outlet pipe. Plumbing must be done in accordance with all applicable local codes.

INSTALLATION

8. **INSTALLING GROUND:** To maintain an electrical ground in metal plumbing of a home's cold water piping (such as a copper plumbing system), install a ground clamp or jumper wiring.

NOTE: If replacing an existing unit, also replace the ground clamps/wire. If removing a unit, replace the piping with the same type of piping as the original to assure plumbing integrity and grounding.

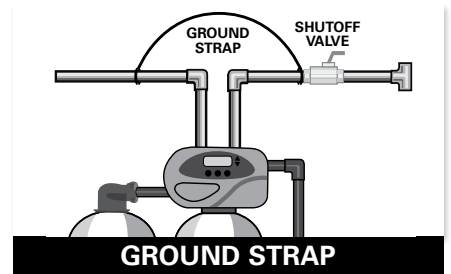

GROUND STRAP

9. **DRAIN LINE:** First, be sure that the drain can handle the backwash rate of the system. Solder joints near the drain must be done prior to connecting the drain line flow control fitting. Leave at least 6" between the drain line flow control fitting and solder joints. Failure to do this could cause interior damage to the flow control. Install a 1/2" I.D. tube to the Drain Line Assembly in accordance with plumbing regulations or discard the tubing nut and use the 3/4" NPT fitting for rigid pipe (recommended). If the backwash rate is greater than 7 gpm, use a 3/4" drain line. Where the drain line is elevated but empties into a drain below the level of the control valve, form a 7" loop at the discharge end of the line so that the bottom of the loop is level with the drain connection on the control valve. This will provide an adequate anti-siphon trap. Piping the drain line overhead <10 ft is normally not a problem. Be sure adequate pressure is available (40-60 psi is recommended). Where the drain empties into an overhead sewer line, a sink-type trap must be used with appropriate air gap (see drawing). Run drain tube to its discharge point in accordance with plumbing codes. Pay special attention to codes for air gaps and anti-siphon devices.



CAUTION: Never insert a drain line into a drain, sewer line, or trap. Always allow an air gap of 1-1/2" or twice the pipe diameter, whichever is greater, between the drain line and the wastewater to prevent the possibility of sewage being back-siphoned into the softener.

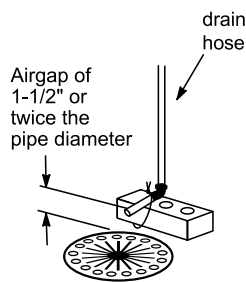

1. Floor Drain

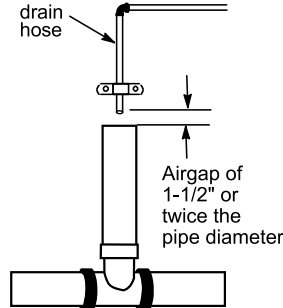

2. Standpipe

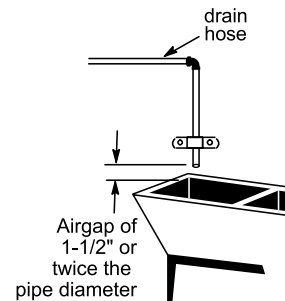

3. Laundry Tub

TYPICAL DRAIN LINE INSTALLATIONS

10. **SAFETY BRINE TANK CONNECTION:** Install the 3/8" O.D. polyethylene tube from the Refill Elbow to the Brine Safety Float valve in the brine tank.



Connection at Refill Elbow on the control valve



**Connection at Refill Elbow on the control valve
(with optional chlorine generator)**

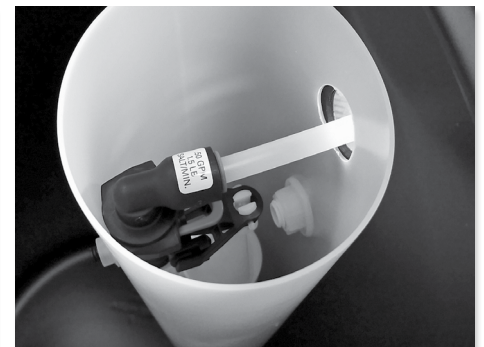

Connection at Brine Safety Float in brine tank

11. **OVERFLOW LINE CONNECTION:** An overflow drain line is recommended where a brine overflow could damage furnishings or the building structure. Your unit is equipped with a brine tank safety float which greatly reduces the chance of an accidental brine overflow. In the event of a malfunction, however, an overflow line connection will direct the "overflow" to the drain instead of spilling on the floor where it could cause considerable damage. This fitting is an elbow on the side of the brine tank. Attach a length of 1/2" I.D. tubing to fitting and run to drain. Do not elevate overflow line higher than 3" below bottom of overflow fitting. Do not connect this tube into the drain line of the control valve. Overflow line must be a direct, separate line from overflow fitting to drain, sewer, or tub. Allow an air gap as per the drain line instructions.

This page intentionally left blank.

PROGRAMMING PROCEDURES:

1. Set Time of Day

Typically, time of day should only need to be set after extended power outages or when daylight saving time begins or ends or after the battery has been replaced. If an extended power outage occurs, the time of day will flash on and off indicating that the time should be reset. To set the clock:

STEP 1 – Press the **CLOCK** button.

STEP 2 – Set the hour of the day using **+** or **-** buttons. AM/PM toggles after 12. Press **NEXT** to go to step 3.

STEP 3 – Set the minutes using **+** or **-** buttons. Press **NEXT** to go to step 4 or **REGEN** to return to previous step.

STEP 4 – Set the day of the week using **+** or **-** buttons. Press **NEXT** to exit clock setting or **REGEN** to return to previous step.

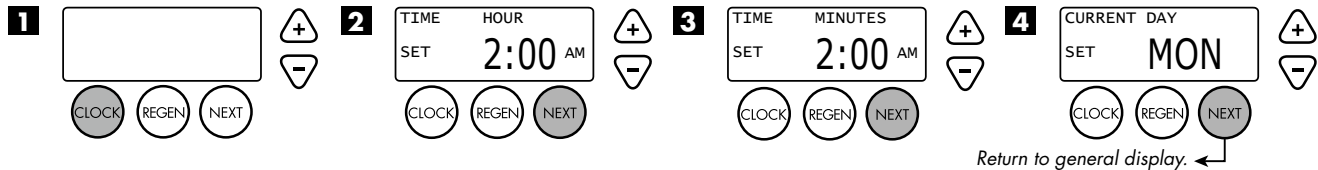

2. Programming

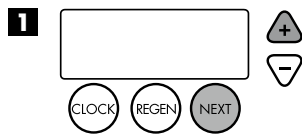

The manufacturer has preset the unit so that the gallons between regenerations will be automatically calculated after the hardness is entered. Press **NEXT** to cycle to the next step or **REGEN** to return to the previous step.

STEP 1 – Press and hold the **NEXT** and **+** buttons simultaneously for 3 seconds.

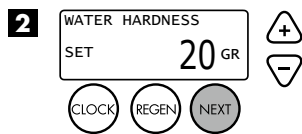

STEP 2 – HARDNESS: Use the **+** or **-** buttons to adjust the hardness value in grains per gallons. Adjustable from 1 to 150 gpg in 1 grain increments (default setting is 20).

The hardness value is based on the actual compensated hardness of the water and must be set by an authorized dealer following an on-site water analysis. Adjusting the number will only impact the frequency of regeneration and will not alter or affect the hardness of the water treated by the unit.

Note: If a resin media is used, increase the grains per gallon if soluble iron is present (1 ppm = 4 gpg). This screen will not display if "FILTER" mode is selected.

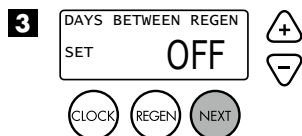

STEP 3 – DAYS BETWEEN REGENERATION (DAY OVERRIDE): Use the **+** or **-** buttons to adjust the day override. Adjustable from 1-28 days or OFF. The manufacturer has factory set OFF as the default for Twin units.

The Day Override value represents the maximum number of days between regenerations. If any number is set (1-28 days), a regeneration will be scheduled for that day if the gallon capacity has not been met. If OFF is set, the unit will only initiate a regeneration once the gallon capacity has been met.

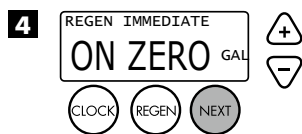

STEP 4 – IMMEDIATE REGENERATION: The manufacturer has set the regeneration to occur when zero gallons remain. When this occurs, the standby tank will switch into service and provide treated water while the tank requiring regeneration will start this process.

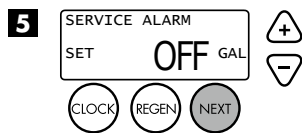

STEP 5 – SERVICE ALARM GALLONS: Use the **+** or **-** buttons to schedule a service alarm by gallons. Adjustable in 100 gallon increments or OFF. The manufacturer has factory set OFF as the default.

This feature is typically set by the installing dealer to warn the homeowner that service is required after a number of gallons have been consumed. If the feature is active, a specific gallon amount will appear. For more information regarding how to set service alarms, the installer should consult the master programming guide that corresponds to the unit being installed.

Press the **NEXT** button three times to advance to the next screen.

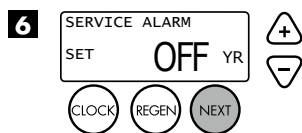

STEP 6 – SERVICE ALARM TIME: Use the **+** or **-** buttons to schedule a service alarm in years. Adjustable in .25 year increments or OFF. The manufacturer has factory set OFF as the default.

This feature is typically set by the installing dealer to warn the homeowner that service is required after an amount of time has passed. If the feature is active, a specific number of days will appear. For more information regarding how to set service alarms, the installer should consult the master programming guide that corresponds to the unit being installed.

Press the **NEXT** button three times to advance to the next screen.

PROGRAMMING PROCEDURES:

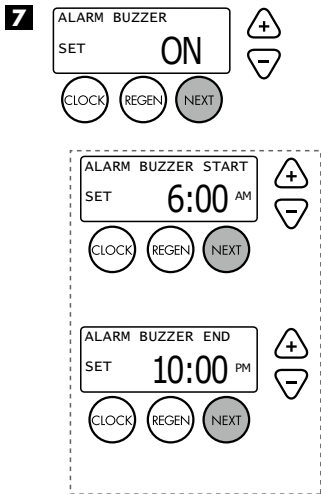

STEP 7 – ALARM BUZZER: Use the **+** or **-** buttons to turn the alarm ON or OFF. Unit is set to ON by default. Alarm will sound after a regeneration warning the owner of possible valve errors or other issues. This alarm is a short 0.5 second burst every 3 seconds. When alarm buzzer is set to ON, pressing the **NEXT** button proceeds to the Alarm Start Time screen. This feature allows the installer to choose a time when the owner will be home or awake to hear the alarm.

BUZZER START TIME: Press the **+** or **-** buttons to select the hour when the buzzer should begin sounding. AM/PM toggles after 12. Default setting is 6:00 a.m.

BUZZER STOP TIME: Press the **+** or **-** buttons to select the hour when the buzzer should stop sounding. AM/PM toggles after 12. Default setting is 10:00 p.m.

STEP 8 – BACKLIGHT DISPLAY CONTROL: Use the **+** or **-** buttons to turn the backlight setting ON or OFF. If unit is set to OFF, the backlight will turn off after 5 minutes of inactivity.

Press **NEXT** to return to General Display.

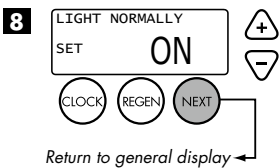

START-UP INSTRUCTIONS

FLUSHING OF SYSTEM:

To flush the system of any debris and air after installation is complete, please perform the following steps:

1. Rotate bypass handles to the bypass mode (**Fig. 2 on page 4**).
2. Turn on inlet water and check for leaks in the newly installed plumbing.
3. Fully open a cold water faucet, preferable at a laundry sink or bathtub without an aerator.
4. Wait two to three minutes or until water runs clear, then turn water off and follow start-up instructions.

Below is the name of each cycle as it appears on the screen with a description of the cycle position. The timing of each cycle will vary depending on the unit size as set from the factory.

Name of Cycle	Description
BACKWASH	BACKWASH
REGENERANT DRAW DOWN	BRINE DRAW AND SLOW RINSE
RINSE	RAPID RINSE
FILL	BRINE TANK FILL

1. With the softener in the bypass mode (**Fig. 2 on page 4**) and the control valve in normal operation where the display shows either the time of day or the gallons remaining, manually add 8" of water to the regenerant tank.

NOTE: If too much water is put into the brine tank during softener start up, it could result in a "salty water" complaint after the first regeneration. During the first regeneration, the unit will draw out the initial volume of brine/regenerant and refill it with the correct, preset amount.

2. With the softener in bypass mode, press and hold the **REGEN** button until the motor starts. Release button. The display will read "Pend 0" for about three seconds while the system transfers from one tank to another. After the transfer is complete, the valve will automatically advance to the "Backwash" position. Once the valve has stopped in this position, unplug the transformer so that the valve will not cycle to the next position. Open the inlet handle of the bypass valve very slightly, allowing water to fill the tank slowly in order to expel air from the tank.



CAUTION: If water flows too rapidly, there will be a loss of media to the drain.

3. When the water is flowing steadily to the drain, clear and without the presence of air, slowly open the inlet valve. Restore power and momentarily press the **REGEN** button to advance the control to the "BRINE" position.
4. With the bypass now in diagnostic mode (**Fig. 3 on page 4**), check to verify that water is being drawn from regenerant tank with no air leaks or bubbles in the brine line. There should be a slow flow to the drain. Disconnect brine line from the safety float valve in the brine tank and check for a vacuum. After proper confirmation, reconnect brine line, making sure to tighten securely.
5. Momentarily press **REGEN** again until the display reads "RINSE." There should be a rapid flow to the drain. Unplug transformer to keep the valve in the "RINSE" position. Allow to run until steady, clear and without air. While the unit is rinsing, load the brine tank with water softener salt (**refer to Brine Tank Maintenance and Salt section**). Restore power.
6. Push **REGEN** again and the unit will advance to the "Brine Refill" position. Check to make sure the brine tank is refilling. The flow rate is usually .5 gpm for all residential and light commercial applications.
7. Push **NEXT** and the unit will return to normal operation.
8. Place unit into bypass mode again (**see Fig. 2 on page 4**) and press and hold the regen button to allow control valve to transfer to the second tank. Follow steps 2-7 to now expel air from this tank.
9. When finished expelling air from second tank, return bypass handles to normal operating position (**see Fig. 1 on page 4**). The unit is now online and soft water is available for use.
10. **CONDITIONING OF MEDIA To flush any remaining debris and air from the system again:**
 1. Fully open a cold water faucet, preferably at a laundry sink or bathtub without an aerator.
 2. Wait two to three minutes or until water runs clear, then turn water off.
 3. Turn on hot water and check for air, then turn water off after air is discharged.

11. SANITIZING OF UNIT UPON INSTALLATION AND AFTER SERVICE:

At this time, it is advised to sanitize the softener:

1. Open brine tank and remove brine well cover.
2. Pour 1 oz. of household bleach into the softener brine well.
NOTE: Avoid pouring bleach directly onto the safety float components in the brine well.
3. Replace brine well cover.

Unit sanitizing will be complete when the first cycle is run and the bleach is flushed from the softener.

12. Check time of day. Start-up is now complete.

OPERATING DISPLAYS AND MAINTENANCE:

1. GENERAL OPERATION: When the system is operating, one of six displays may be shown and will alternate with the installing dealer's name and phone number for future service. Pressing **NEXT** will alternate between the displays.

1. **Time of Day Screen:** Displays the current time of day, the day of the week, and flow rate. Letter indicates which tank is in service.
2. **Flow Rate Screen:** Displays the current treated water flow rate through tank A or B in Gallons Per Minute.
3. **Vacation Mode Screen:** Allows the system to be "shut down" when there will be no water usage for an extended period of time.
4. **Capacity Remaining Screen:** Displays the amount of gallons of treated water remaining for the tank in service until the system triggers a regeneration and switches to the other tank.
5. **Days to a Regen Screen:** Displays the number of days until the system triggers a regeneration. Based on the days override value.
6. **Dealer Name Screen:** Displays dealer specific name and phone number. This scrolling display will only appear if set by the dealer.

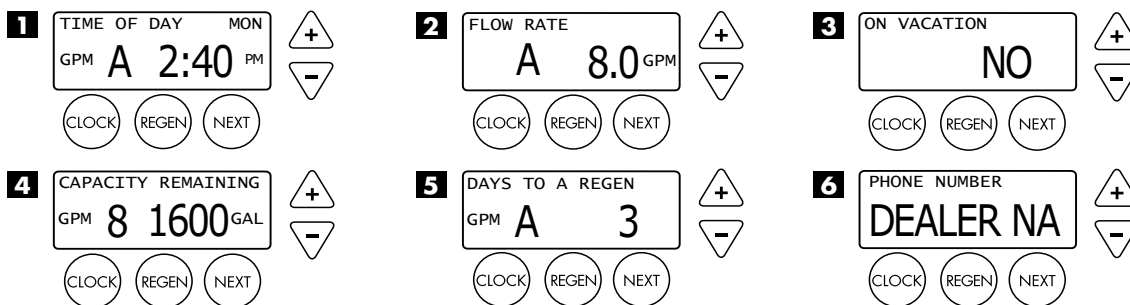

2. VACATION MODE: This feature may be used to "shut down" the system for a period of time by preventing the unit from regenerating. The manufacturer has factory set "OFF" as the default. Turn feature "OFF" or "ON" using the + or - buttons. When turned "ON", the unit will remain in Vacation Mode until it is exited. There are two ways that a unit can exit Vacation Mode:

Manually: The user may manually exit Vacation Mode by changing the setting from "ON" to "OFF". Once switched off, a delayed regeneration will queue for that night. Vacation mode may also be manually exited by holding the REGEN button to force an immediate regeneration.

Automatically: The unit will automatically exit Vacation Mode once water usage has resumed. After fifty gallons of water is used, the unit will set to resume normal operation and a delayed regeneration will queue for that night.

NOTE: In some instances, if a regeneration has been queued and the unit is taken out of Vacation Mode (manually or automatically), the unit will trigger an immediate regeneration instead of a delayed regeneration. For example, if the unit's maximum Days Between Regeneration is reached while the unit is in Vacation Mode, an immediate regeneration will trigger as soon as the unit is taken out of Vacation Mode.



CAUTION: Depending on the severity of water conditions and the length of no water usage, it may not be recommended to use this feature. Please contact dealer or manufacturer for more information.

3. REGENERATION MODE: Typically a twin system regenerates when the capacity of the tank providing treated water reaches zero remaining gallons. At this time, the online tank will transfer and put the standby tank online so there is no disruption of treated water. Once this transfer is complete, the depleted tank will regenerate and return to standby mode ready to enter service upon depletion of capacity of other tank. This two tank configuration provides for a continuous, uninterrupted supply of conditioned water at all times. When the system begins to regenerate, the display will change to include information about the step of the regeneration process and the time remaining for that step to be completed. The system will run through all remaining steps automatically and will reset to provide treated water when the regeneration process has been completed.

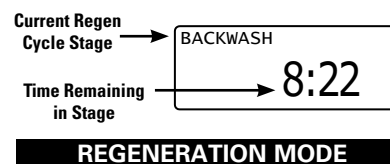

4. MANUAL REGENERATION: Sometimes there may be a need to regenerate a unit before the control valve calls for it. This may be needed if the system has been operating without salt for an extended period of time.

- To initiate a manual regeneration immediately, press and hold the **REGEN** button for three seconds. The system will begin to regenerate immediately. **This command cannot be canceled.**

Once a manual regeneration is initiated, the unit will transfer to the second tank in order to supply conditioned water. Upon transfer, the depleted tank will begin its regeneration.

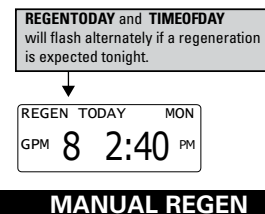

OPERATING DISPLAYS AND MAINTENANCE:

5. POWER LOSS AND BATTERY REPLACEMENT: If an extended power outage occurs, the control valve will retain the time of day settings until the board's battery is depleted. Once the battery is depleted, the display will appear dark and absent of any information. If this occurs, following these steps will determine if the problem is a low battery or a board failure.

To determine if the battery is depleted:

1. Remove valve cover. Disconnect power from PC Board at the four pin connector at the bottom of the board.
2. Wait five minutes for board to de-energize. Remove battery with a non-conductive/non-metallic material. Reference the Parts Breakdown section of this manual for location.
3. Wait five minutes for board to de-energize.
4. With the battery out, re-connect the power supply to the board. The board's display should begin to show information.

This indicates that the board is operating correctly. If the display does not work, call installing dealer for service.

5. To replace with new battery, unplug transformer from outlet. Install a 3 volt Lithium Coin Cell type 2032 battery, available at most stores. Plug unit back into outlet.

It is important to replace the battery with the valve unplugged to avoid causing a short and potentially ruining the board.

6. Reset the time of day (see programming procedures) and initiate regeneration (see operating displays and maintenance).

If these procedures do not remedy the problem, please consult the installing dealer for service.

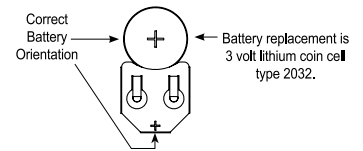

When replacing the battery, align positives and push down to fully seat.



Battery Fully Seated

BATTERY REPLACEMENT

6. ERROR MESSAGE: If the word "ERROR" appears and flashes alternately with the dealer name and phone number, record the ERROR number and contact your servicing dealer promptly. This indicates that the control valve was not able to function properly.



ERROR SCREEN

7. BRINE TANK MAINTENANCE AND SALT: Refill the brine tank as necessary, making sure at least 1/3 of the brine tank is full at all times. Without proper salt levels, the water softener may not operate properly.

Because "typical" settings of this water softener include a dry salt storage feature (a small amount of water in brine tank between regeneration), the manufacturer recommends the use of solar salt for best results. The brine tank is manufactured for the use of solar, pellets or rock salt. **Do not use block salt.** If pellet or rock salt is used, a cleaning of the brine tank every six months is recommended. If the dry salt storage feature is not being utilized, block salt may be used.



CAUTION: With some models the manufacturer does NOT recommend the use of any resin cleaners, nor placing any resin cleaners into the brine tank. Furthermore, do not use any salt that indicates it is an iron cleaning salt or that contains any cleaning additives. This may be harmful to the water softener and for human consumption. Consult dealer for proper cleaning instructions.

8. CHECK SALT INDICATOR AND AUDIBLE ALARM: This control valve is equipped with a low salt warning to alert homeowners that the system is operating in a low salt condition. This usually indicated that the salt level in the brine tank is too low to operate properly. If "CHECK SALT" appears on the screen, there will usually be an audible alarm that sounds also (if turned on), alerting you to these conditions.



SALT ALARM SCREEN

TO TURN OFF ALARM: If the audible alarm sounds due to a low salt condition, press any button on the face of the control valve to turn off. If the salt is not added to the brine tank before the next regeneration, the CHECK SALT indicator will alarm again. This will repeat until the problem is corrected.

TROUBLESHOOTING GUIDE

PROBLEM	CAUSE	CORRECTION
1. No display on PC board.	A. Depleted battery.	A. See Operating Display and Maintenance section.
	B. Control valve power adapter not plugged into outlet or power cord end not connected to PC board connection.	B. Plug power adapter into outlet or connect power cord end to PC board connection.
	C. Improper power supply.	C. Verify proper voltage is being delivered to PC board.
	D. Defective power adapter.	D. Replace power adapter.
	E. Defective PC board.	E. Replace PC board.
	F. No power at electric outlet.	F. Repair outlet or use working outlet.
2. PC board does not display correct time of day.	A. Power adapter plugged into electric outlet controlled by light switch.	A. Use uninterrupted outlet.
	B. Tripped breaker switch and/or tripped GFI.	B. Reset breaker switch and/or GFI switch.
	C. Power outage.	C. Reset time of day. If PC board has battery back up present the battery may be depleted. See front cover and drive assembly drawing for instructions.
	D. Defective PC board.	D. Replace PC board.
3. Display does not indicate that water is flowing. Refer to user instructions for how the display indicates water is flowing.	A. Bypass valve in bypass position.	A. Turn bypass handles to place bypass in service position.
	B. Meter is not connected to meter connection on PC board.	B. Connect meter to three pin connection labeled METER on PC board.
	C. Restricted/stalled meter turbine.	C. Remove meter and check for rotation or foreign material.
	D. Meter wire not installed securely into three pin connector.	D. Verify meter cable wires are installed securely into three pin connector labeled METER.
	E. Defective meter.	E. Replace meter.
	F. Defective PC board.	F. Replace PC board.
4. Control valve regenerates at wrong time of day.	A. Power outage.	A. Reset time of day. If PC board has battery back up present the battery may be depleted. See front cover and drive assembly drawing for instructions.
	B. Time of day not set correctly.	B. Reset to correct time of day.
	C. Time of regeneration set incorrectly.	C. Reset regeneration time.
	D. Control valve set at immediate regeneration.	D. Check programming setting and reset to DELAYED (for a delayed regen time).
5. Time of day flashes on and off.	A. Power outage.	A. Reset time of day. If PC board has battery back up present the battery may be depleted. See front cover and drive assembly drawing for instructions.
6. Control valve does not regenerate automatically when the correct button(s) is pressed and held. For timeclock valves the buttons are + or -. For all other valves the button is REGEN.	A. Broken drive gear or drive cap assembly.	A. Replace drive gear or drive cap assembly.
	B. Broken piston rod.	B. Replace piston rod.
	C. Defective PC board.	C. Defective PC board.
	D. Cover installed incorrectly.	D. Reinstall cover.

TROUBLESHOOTING GUIDE

PROBLEM	CAUSE	CORRECTION
7. Control valve does not regenerate automatically but does when the correct button(s) is depressed and held. For timeclock valves the buttons are + or -. For all other valves the button is REGEN.	A. Bypass valve in bypass position.	A. Turn bypass handles to place bypass in service position.
	B. Meter is not connected to meter connection on PC board.	B. Connect meter to three pin connection labeled METER on PC board.
	C. Restricted/stalled meter turbine.	C. Remove meter and check for rotation or foreign material.
	D. Incorrect programming.	D. Check for programming error.
	E. Meter wire not installed securely into three pin connector.	E. Verify meter cable wires are installed securely into three pin connector labeled METER.
	F. Defective meter.	F. Replace meter.
	G. Defective PC board.	G. Replace PC board.
8. Hard or untreated water is being delivered.	A. Bypass valve is open or faulty.	A. Fully close bypass valve or replace.
	B. Media is exhausted due to high water usage.	B. Check program settings or diagnostics for abnormal water usage.
	C. Meter not registering.	C. Remove meter and check for rotation or foreign material.
	D. Water quality fluctuation.	D. Test water and adjust program values accordingly.
	E. No regenerant or low level of regenerant in regenerant tank.	E. Add proper regenerant to tank.
	F. Control fails to draw in regenerant.	F. Refer to Troubleshooting Guide number 12.
	G. Insufficient regenerant level in regenerant tank.	G. Check refill setting in programming. Check refill flow control for restrictions or debris and, if necessary, replace.
	H. Damaged seal/stack assembly/piston.	H. Replace seal/stack assembly and/or piston.
	I. Control valve body type and piston type mix matched.	I. Verify proper control valve body type and piston type match.
	J. Fouled media bed.	J. Replace media bed.
9. Control valve uses too much regenerant.	A. Improper refill setting.	A. Check refill setting.
	B. Improper program settings.	B. Check program setting to make sure they are specific to the water quality and application needs.
	C. Control valve regenerates frequently.	C. Check for leaking fixtures that may be exhausting capacity or system is undersized.
10. Residual regenerant being delivered to service.	A. Low water pressure.	A. Check incoming water pressure – water pressure must remain at minimum of 25 psi.
	B. Incorrect, damaged, or restricted injector.	B. Replace injector with correct size for the application.
	C. Restricted drain line.	C. Check drain line for restrictions or debris and remove any obstructions.
11. Excessive water in regenerant tank.	A. Improper program settings.	A. Check refill setting.
	B. Plugged injector.	B. Remove injector and replace.
	C. Drive cap assembly not tightened in properly.	C. Re-tighten the drive cap assembly.
	D. Damaged seal/stack assembly/piston.	D. Replace seal/stack assembly and/or piston.
	E. Restricted or kinked drain line.	E. Check drain line for restrictions or debris and or unkink drain line.
	F. Plugged backwash flow controller.	F. Remove backwash flow controller and replace, if necessary.
	G. Missing refill flow controller.	G. Install refill flow controller.
	H. Brine tube not inserted properly into brine elbow in brine tank.	H. Install tube all the way into elbow.

TROUBLESHOOTING GUIDE

PROBLEM	CAUSE	CORRECTION
12. Control valve fails to draw in regenerant.	A. Injector is plugged.	A. Remove injector and replace.
	B. Faulty regenerant piston.	B. Replace regenerant piston.
	C. Regenerant line connection leak.	C. Inspect regenerant line for air leak.
	D. Drain line restriction or debris cause excess back pressure.	D. Inspect drain line and remove to correct restriction.
	E. Drain line too long or too high.	E. Shorten length and or height.
	F. Low water pressure.	F. Check incoming water pressure – water pressure must remain at minimum of 25 psi.
13. Water running to drain.	A. Power outage during regeneration.	A. Upon power being restored control will finish the remaining regeneration time. Reset time of day. If PC board has battery back up present the battery may be depleted. See front cover and drive assembly drawing for instructions.
	B. Damaged seal/stack assembly.	B. Replace seal/stack assembly.
	C. Piston assembly failure.	C. Replace piston assembly.
	D. Drive cap assembly not tightened in properly.	D. Re-tighten the drive cap assembly.
14. E1, Err – 1001, Err – 101 = Control unable to sense motor movement.	A. Motor not inserted full to engage pinion, motor wires broken or disconnected.	A. Disconnect power, make sure motor is fully engaged, check for broken wires, make sure two pin connector on motor is connected to the two pin connection on the PC board labeled MOTOR. Press NEXT and REGEN buttons for 3 seconds to resynchronize software with piston position or disconnect power supply from PC board for 5 seconds and then reconnect.
	B. PC board not properly snapped into drive bracket.	B. Properly snap PC board into drive bracket and then Press NEXT and REGEN buttons for 3 seconds to resynchronize software with piston position or disconnect power supply from PC board for 5 seconds and then reconnect.
	C. Missing drive gears.	C. Replace missing gears.
	D. Motor does not drive/run.	D. Replace motor.
	E. Viewing eye or encoder is blocked or damaged.	E. clear viewing eye on board, on drive bracket, or replace PC board if no debris is found.
15. E2, Err – 1002, Err – 102 = Excessive Motor Draw.	A. Foreign material is lodged in control valve.	A. Open up control valve and pull out piston assembly and seal/stack assembly for inspection. Press NEXT and REGEN buttons for 3 seconds to resynchronize software with piston position or disconnect power supply from PC board for 5 seconds and then reconnect.
	B. Mechanical binding.	B. Check piston and seal/stack assembly, check reduction gears, check drive bracket and main drive gear interface. Press NEXT and REGEN buttons for 3 seconds to resynchronize software with piston position or disconnect power supply from PC board for 5 seconds and then reconnect.
	C. Drive cap too loose.	C. Completely tighten drive cap assembly.
	D. Drive cap not “clicked” into backplate.	D. Verify that backplate is properly “clicked” into place.

TROUBLESHOOTING GUIDE

PROBLEM	CAUSE	CORRECTION
16. E3, Err – 1003, Err – 103 = Control valve motor ran too long and was unable to find the next cycle position.	A. Drive bracket not snapped in properly and out enough that reduction gears and drive gear do not interface.	A. Snap drive bracket in properly then Press NEXT and REGEN buttons for 3 seconds to resynchronize software with piston position or disconnect power supply from PC board for 5 seconds and then reconnect.
17. E4, Err – 1004, Err – 104 = Control valve motor ran too long and timed out trying to reach home position.	A. Drive bracket not snapped in properly and out enough that reduction gears and drive gear do not interface.	A. Snap drive bracket in properly then Press NEXT and REGEN buttons for 3 seconds to resynchronize software with piston position or disconnect power supply from PC board for 5 seconds and then reconnect.
	B. Piston not connected to drive cap.	B. Connect or replace (if damaged) piston/drive cap.
18. Err – 1006, Err – 106, Err – 116 = MAV/ SEPS/ NHBP/ AUX MAV valve motor ran too long and unable to find the proper park position. <ul style="list-style-type: none"> ● Motorized Alternating Valve = MAV ● Separate Source = SEPS ● No Hard Water Bypass = NHBP ● Auxiliary MAV = AUX MAV 	A. Control valve programmed for ALT A or B, nHbP, SEPS, or AUX MAV with out having a MAV or NHBP valve attached to operate that function.	A. Press NEXT and REGEN buttons for 3 seconds to resynchronize software with piston position or disconnect power supply from PC board for 5 seconds and then reconnect. Then reprogram valve to proper setting.
	B. MAV/NHBP motor wire not connected to PC board.	B. Connect MAV/NHBP motor to PC board two pin connection labeled DRIVE. Press NEXT and REGEN buttons for 3 seconds to resynchronize software with piston position or disconnect power supply from PC board for 5 seconds and then reconnect.
	C. MAV/NHBP motor not fully engaged with reduction gears.	C. Properly insert motor into casing, do not force into casing Press NEXT and REGEN buttons for 3 seconds to resynchronize software with piston position or disconnect power supply from PC board for 5 seconds and then reconnect.
	D. Foreign matter built up on piston and stack assemblies creating friction and drag enough to time out motor.	D. Replace piston and stack assemblies. Press NEXT and REGEN buttons for 3 seconds to resynchronize software with piston position or disconnect power supply from PC board for 5 seconds and then reconnect.
19. Err – 1007, Err – 107, Err – 117 = MAV/ SEPS/NHBP/ AUX MAV valve motor ran too short (stalled) while looking for proper park position. <ul style="list-style-type: none"> ● Motorized Alternating Valve = MAV ● Separate Source = SEPS ● No Hard Water Bypass = NHBP ● Auxiliary MAV = AUX MAV 	A. Foreign material is lodged in MAV/NHBP valve.	A. Open up MAV/NHBP valve and check piston and seal/ stack assembly for foreign material. Press NEXT and REGEN buttons for 3 seconds to resynchronize software with piston position or disconnect power supply from PC board for 5 seconds and then reconnect.
	B. Mechanical binding.	B. Check piston and seal/stack assembly, check reduction gears, drive gear interface, and check MAV/NHBP black drive pinion on motor for being jammed into motor body. Press NEXT and REGEN buttons for 3 seconds to resynchronize software with piston position or disconnect power supply from PC board for 5 seconds and then reconnect.

TROUBLESHOOTING GUIDE

PROBLEM	CAUSE	CORRECTION
20. Err – 201 200 errors are only viewable in history screens. These do not flash when error occurs.	A. Invalid regeneration cycle step detected.	A. Replace PC board.
21. Err – 202 200 errors are only viewable in history screens. These do not flash when error occurs.	A. Short power disruption.	A. Check transformer voltage and verify power source.
	B. Foreign material dislodged.	B. Check piston and stack for damage.
22. Err – 204 = Leak detected 200 errors are only viewable in history screens. These do not flash when error occurs.	A. Occurs when dP input is active for “ALARM” and the input is closed. The alarm buzzer will activate and the screen will display the error.	A. Check for low flow leak. Press NEXT and REGEN buttons for 3 seconds to resynchronize software with piston position or disconnect power supply from PC Board for 5 seconds and then reconnect to clear error.
23. Err – 400* Memory Errors *All 400 errors pertain to memory related errors. 400 and 200 errors are only viewable in history screens. These do not flash when error occurs.	A. Depleted Battery.	A. See Operating Display and Maintenance section.
	B. Defective PC Board.	B. Replace PC board.

This page intentionally left blank.

This page intentionally left blank.

REPLACEMENT PARTS:

FRONT COVER AND DRIVE ASSEMBLY

Item #	Legacy Part #	Current Part #	Description	Qty.
1	CV3367-01-A	100246343	Evolve black cover assembly	1
	CV3367-01WR-A	100246345	Evolve gray cover assembly	1
2	CV3107-1	100246273	Motor Assembly	1
3	CV3002-A	100246193	Drive assembly (includes #5 and #6)	—
4	CV3502WE-04	100244198	PC board EVR/EVRC/EV1/EV2 (chlorine generator models)	1
	CV4097YE-05	100244915	PC board EVR/EVRC/EV1/EV2 (Wripli-capable models)	1
	CV4022WU-04	100249868	PC board Evolve (standard)	1
5	CV3110	100246279	Drive gear, 12 x 36	3
6	CV3109	100246278	Drive gear cover	1
not shown	CV3526	100249866	Transformer, 110V-15V (used on chlorine generator models)	1
	CV3186-06	100249863	Transformer, 110V-12V (standard)	1
	CV3684-WR-GLD	100244240	Optional weather cover	1

NOTE: Battery Location

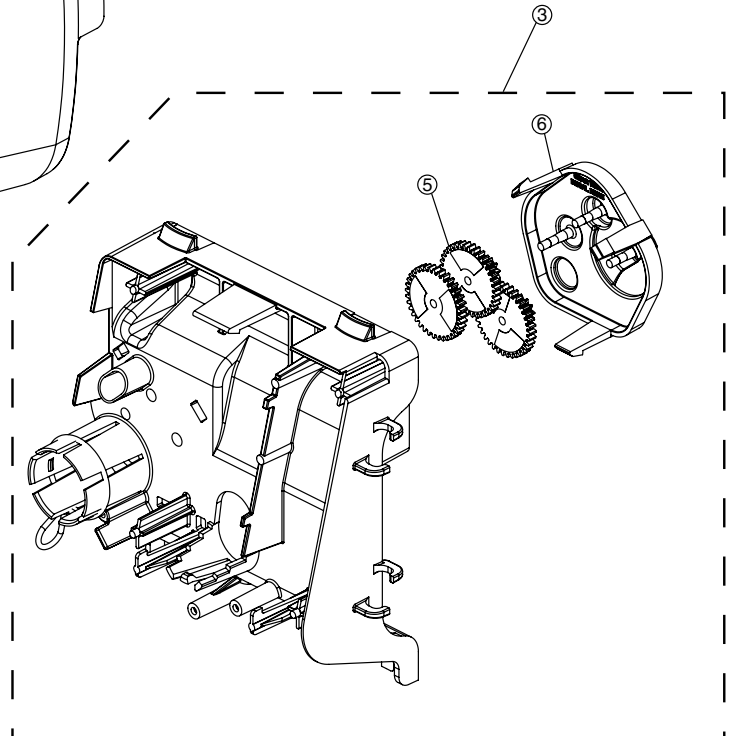
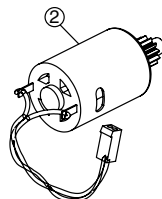
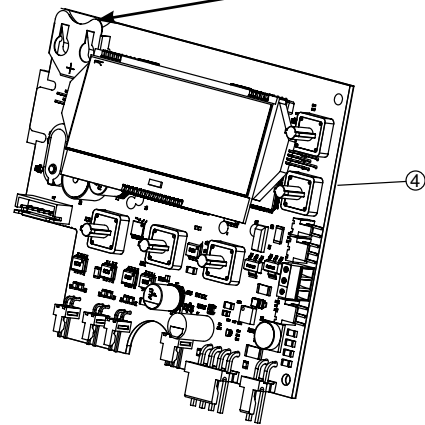
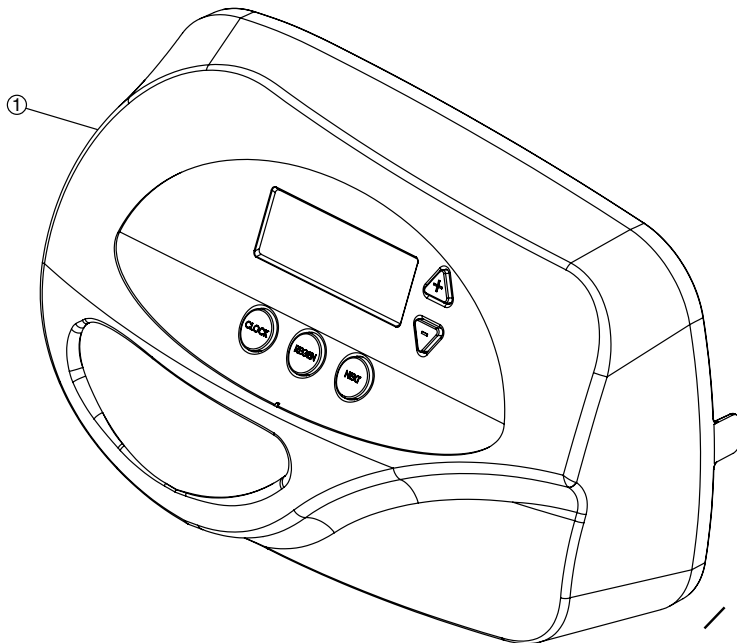

REPLACEMENT PARTS

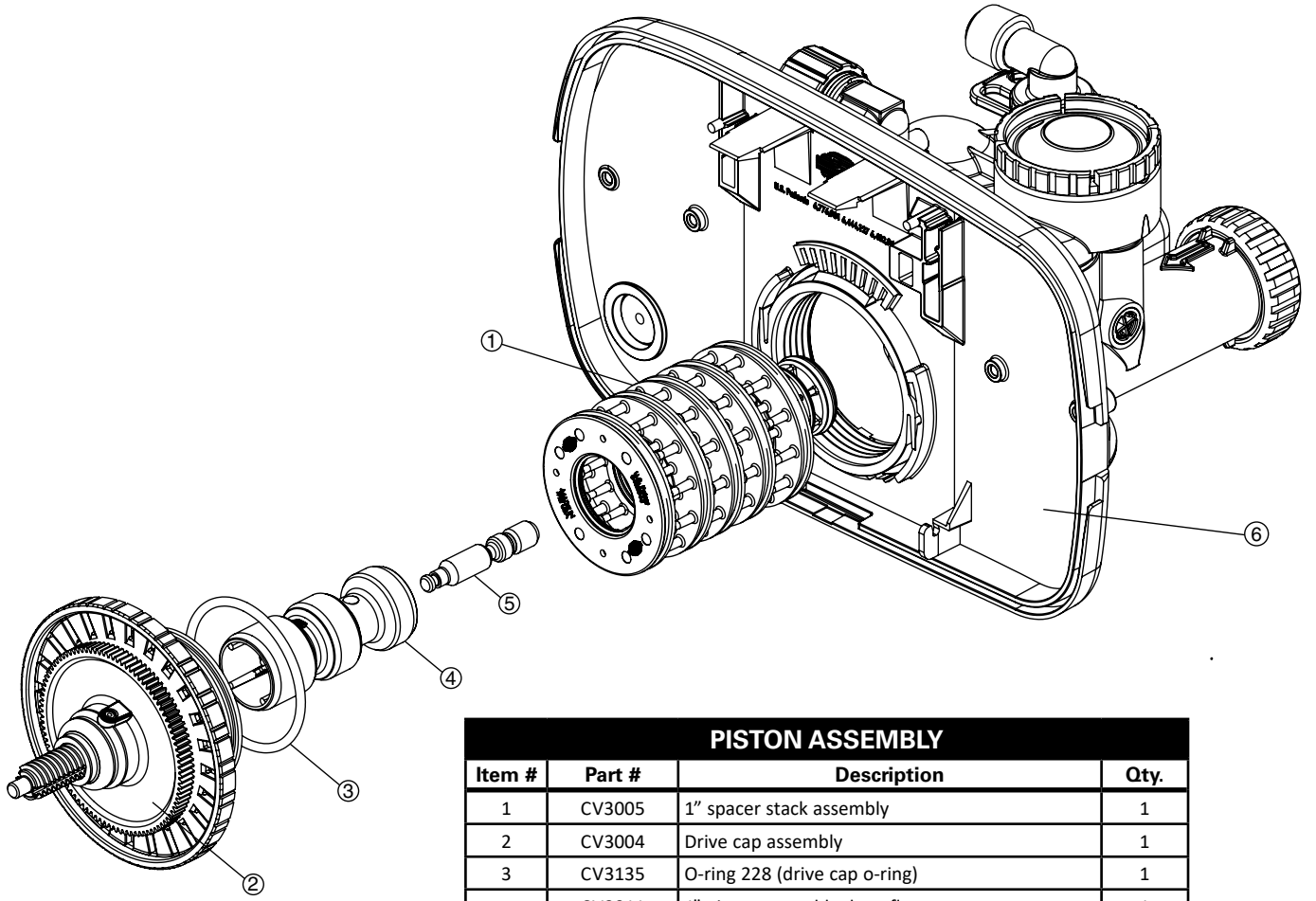

PISTON ASSEMBLY			
Item #	Part #	Description	Qty.
1	CV3005	1" spacer stack assembly	1
2	CV3004	Drive cap assembly	1
3	CV3135	O-ring 228 (drive cap o-ring)	1
4	CV3011	1" piston assembly downflow	1
	CV3011-01	1" piston assembly upflow	1
5	CV3174	Regenerant piston	1
6	CV3368	Drive backplate	1

IN/OUT HEAD (FOR TANK B)			
Item #	Part #	Description	Qty.
	CD1400	1191 In/Out head (includes O-rings)	1
1	CV3180	O-ring 337	1
2	CV3105	O-ring 215	1

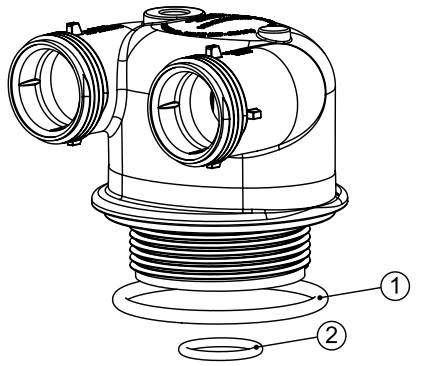

REPLACEMENT PARTS

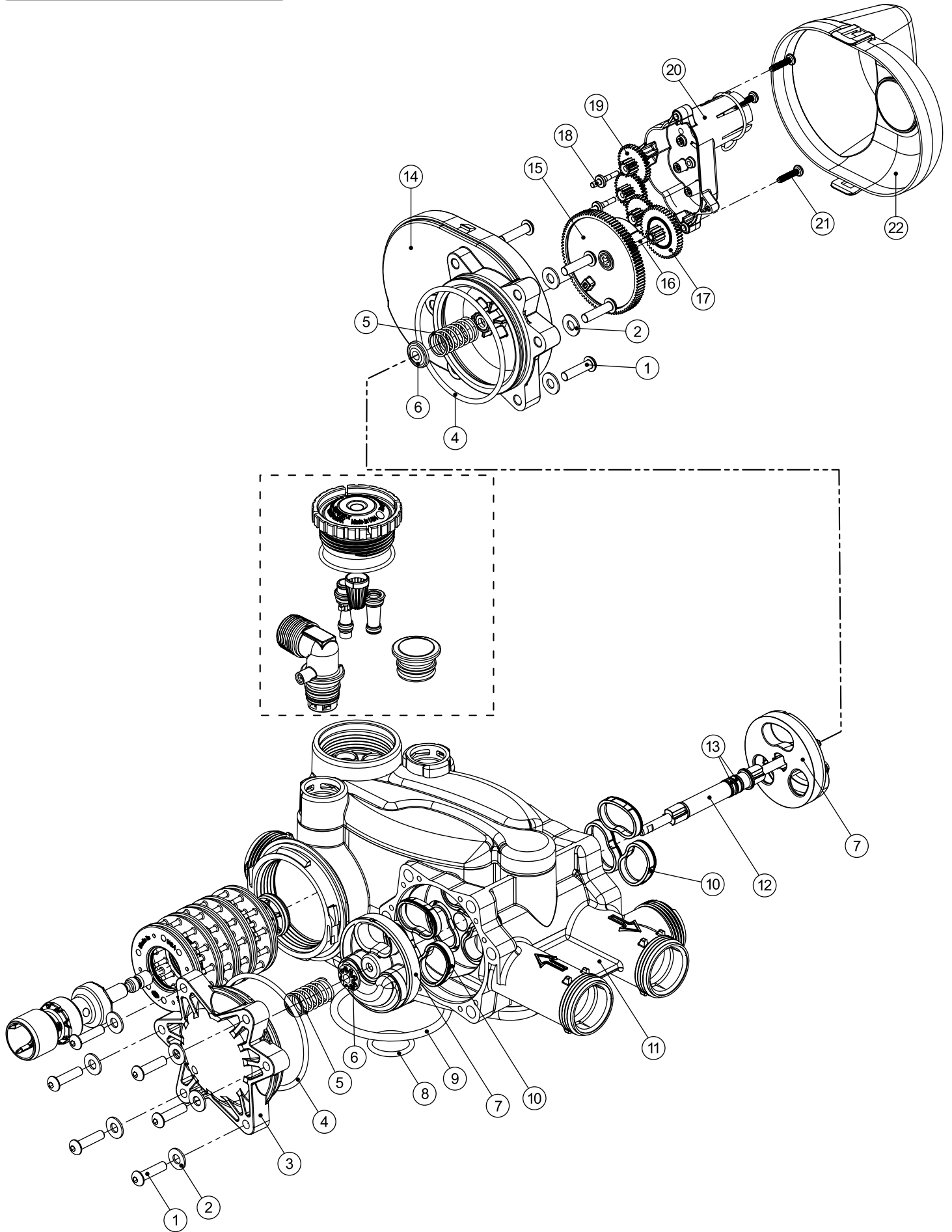

REPLACEMENT PARTS

TWIN TRANSFER				
Item #.	Legacy Part #	Current Part #	Description	Qty.
1	CV3470	100343288	Screw, BHC 1/4 - 20 x 1 SS	12
2	CV3724	100173781	Washer, flat SS 1/4	12
3	CV4005-01	100358458	T1 transfer cap assembly	1
4	CV4029	100246440	O-ring 236	2
5	CV4015	100343287	T1 transfer spring	2
6	CV4014	100246434	T1 transfer spring support	2
7	CV4036	100246441	T1 rotor disk assembly	2
8	CV3105	100246272	O-ring 215 (distributor tube)	1
9	CV3180	100246307	O-ring 337	1
10	CV4016	100246435	T1 transfer seal	6
11	CV3031	100358457	T1 body sft wtr regen	1
12	CV4023	100246439	T1 transfer drive shaft assembly	1
13	CV3287	100246338	O-ring 110	2
14	CV4006-01	100358456	T1 transfer drive cap assembly	1
15	CV4011-01	100343285	T1 transfer drive gear assembly	1
16	CV4012	100358455	T1 transfer drive gear axle	1
17	CV4013	100246433	T1 transfer reduction gear	1
18	CV3264	100244912	WS2H bypass reduction gear axle	3
19	CV3110	100246279	WS1 drive reducing gear 12 x 36	3
20	CV3262-01	100244508	WS1.5 & 2 ALT/2BY reduction gear cover assembly	1
21	CV3592	100246388	Screw, #8-1 PHPN T-25 SS	3
22	CV4049	100358178	T1 cover assembly	1
not shown	CV4043	100246443	T1 transfer motor assembly	1
not shown	CV3151	100246287	WS1 nut 1 QC	1
not shown	CV4055*	100246446	Twin tank meter assembly	1
not shown	CV4017-01	100246436	T1 interconnect fitting assembly	1
not shown	CD1400	100245769	1191 In/Out head	1
not shown	CD1225-05	100249834	Top basket softener (optional)	1
*This water meter should not be used as the primary monitoring device for critical or health effect applications.				

REPLACEMENT PARTS

BYPASS VALVE

Item #.	Legacy Part #	Current Part #	Description	Qty.
1	CV3006	100249845	Bypass assembly	1
2	CV3147	100246284	Bypass handles	2

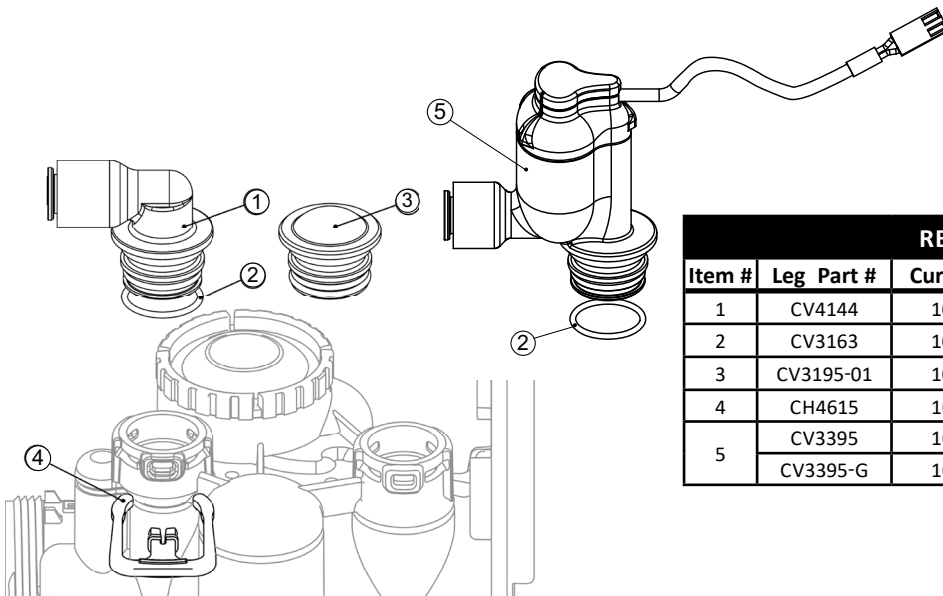
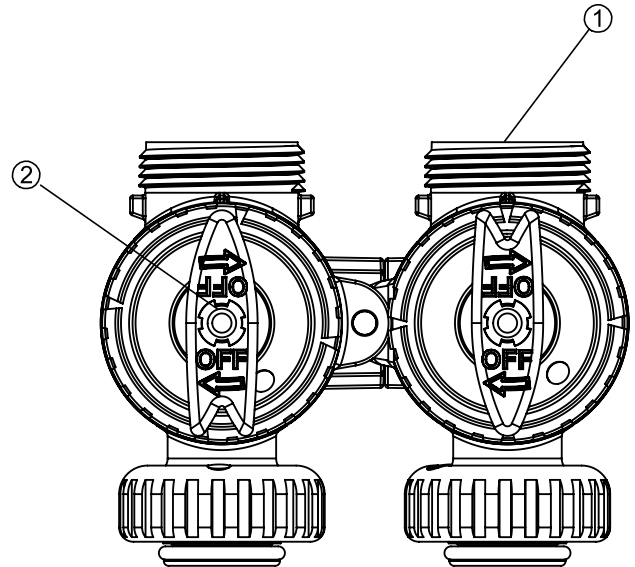

REFILL PORT ASSEMBLY

Item #	Leg Part #	Current Part #	Description	Qty.
1	CV4144	100245015	3/8" Elbow, Parker fitting	1
2	CV3163	100246291	O-ring 019	1
3	CV3195-01	100246323	Refill port plug assembly	1
4	CH4615	100245862	Elbow locking clip	1
5	CV3395	100243726	Chlorine Generator (Black)	1
	CV3395-G	100246347	Salt Monitor (Gray)	1

SERVICE WRENCH - 100249864 (CV3193-02)

Although no tools are necessary to assemble or disassemble the valve, the Service Wrench, (shown in various positions on the valve) is available to aid in assembly or disassembly.

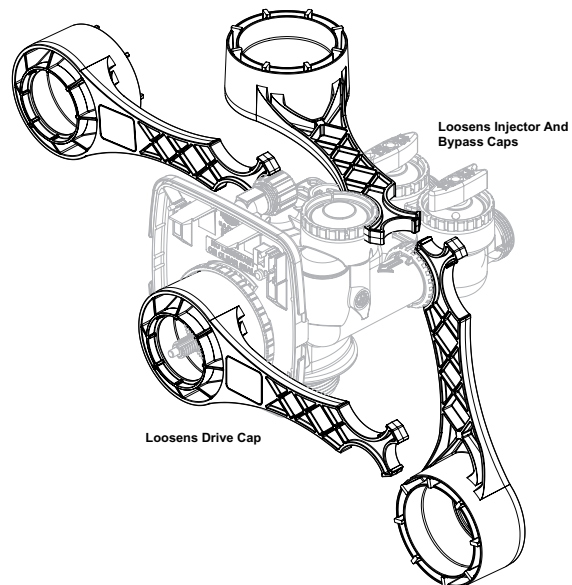

REPLACEMENT PARTS

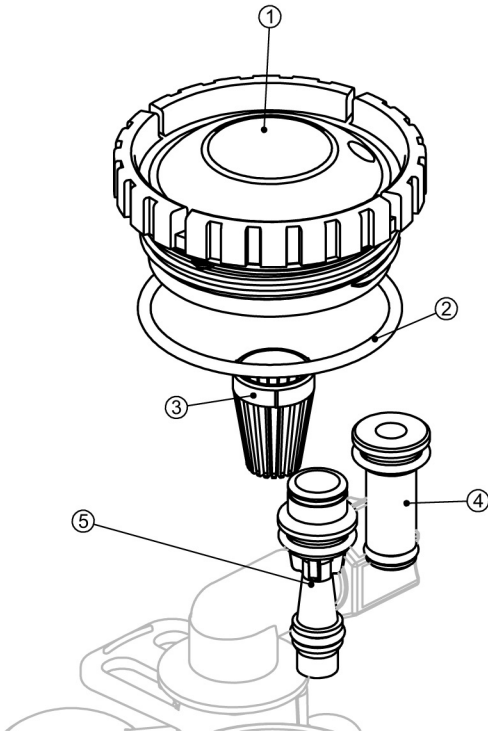

INJECTOR ASSEMBLIES				
Item #	Legac art #	Current Part #	Description	Qty.
1	CV3176	100246304	Injector cap	1
2	CV3152	100244507	O-ring 135	1
3	CV3177-01	100246305	Injector screen	1
4	CV3010-1Z	100246221	Injector assembly plug	1
5	CV3010-1A	100246211	A injector assembly, BLACK	1
	CV3010-1B	100246212	B injector assembly, BROWN	
	CV3010-1C	100246213	C injector assembly, VIOLET	
	CV3010-1D	100249849	D injector assembly, RED	
	CV3010-1E	100246214	E injector assembly, WHITE	
	CV3010-1F	100246215	F injector assembly, BLUE	
	CV3010-1G	100246216	G injector assembly, YELLOW	
	CV3010-1H	100246217	H injector assembly, GREEN	
	CV3010-1I	100246218	I injector assembly, ORANGE	
	CV3010-1J	100246219	J injector assembly, LIGHT BLUE	
CV3010-1K	100246220	K injector assembly, LIGHT GREEN		
not shown	CV3170	100246294	O-ring 011, lower	*
not shown	CV3171	100246295	O-ring 013, upper	*

*The injector plug and the injector each use one lower and one upper o-ring

WATER METER AND METER PLUG				
Item #	Legacy Part #	Current Part #	Description	Qty.
1	CV3151	100246287	Nut, 1" Quick Connect	1
2	CV3003	100246194	Meter assembly	1
3	CV3003-01	100246195	Meter plug assembly	1

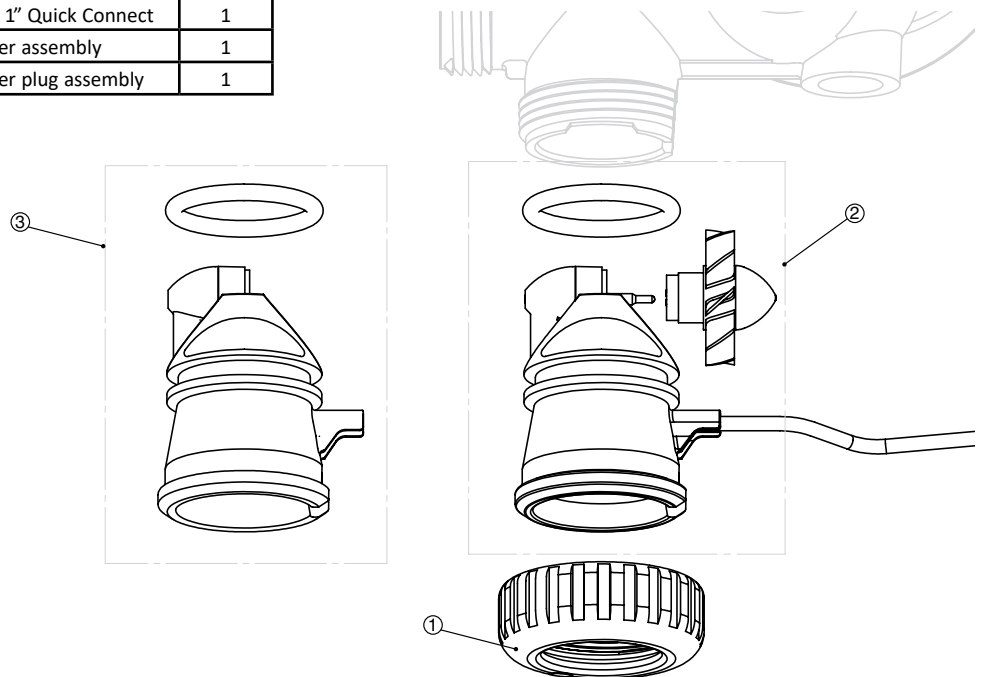

REPLACEMENT PARTS

DRAIN LINE ASSEMBLY 3/4"

Item #	Legacy Part #	Current Part #	Description	Qty.
1	CH4615	100245862	Elbow locking clip	1
2	CPKP10TS8-BULK	100245919	Optional insert, 5/8" tube	1
3	CV3192	100246322	Optional nut, 3/4" drain elbow	1
4	CV3158-02	100249851	Drain elbow, 3/4" NPT with O-ring	1
5	CV3163	100246291	O-ring 019	1
6	CV3159-01	100246290	DLFC retainer assembly	1
7	CV3162-007	100244908	0.7 DLFC for 3/4" elbow	1
	CV3162-010	100244909	1.0 DLFC for 3/4" elbow	
	CV3162-013	100244910	1.3 DLFC for 3/4" elbow	
	CV3162-017	100244911	1.7 DLFC for 3/4" elbow	
	CV3162-022	100249852	2.2 DLFC for 3/4" elbow	
	CV3162-027	100249853	2.7 DLFC for 3/4" elbow	
	CV3162-032	100249854	3.2 DLFC for 3/4" elbow	
	CV3162-042	100249855	4.2 DLFC for 3/4" elbow	
	CV3162-053	100249856	5.3 DLFC for 3/4" elbow	
	CV3162-065	100249857	6.5 DLFC for 3/4" elbow	
CV3162-075	100249858	7.5 DLFC for 3/4" elbow		
8	CV3331A	100245051	Drain elbow and retainer assembly	

Items 2 and 3, nut and insert are only used with 1/2" I.D. by 5/8" O.D. polytubing. For other piping material, the 3/4" NPT is used.

DRAIN LINE ASSEMBLY 1"

Item #	Legacy Part #	Current Part #	Description	Qty.
1	CH4615	100245862	Elbow locking clip	1
2	CV3166	100246292	Drain FTG body 1	1
	CV3166-01	100246293	FTG flow control body 1	
3	CV3163	100246291	O-ring 019	1
4	CV3150	100246286	Split ring	1
5	CV3151	100246287	Nut 1" QC	1
6	CV3105	100246272	O-ring 215	
7	CV3190-090	100246313	9.0 gpm DLFC for 1" elbow	One DLFC must be used if 1" fitting is used
	CV3190-100	100246314	10.0 gpm DLFC for 1" elbow	
	CV3190-110	100246315	11.0 gpm DLFC for 1" elbow	
	CV3190-130	100246316	13.0 gpm DLFC for 1" elbow	
	CV3190-150	100246317	15.0 gpm DLFC for 1" elbow	
	CV3190-170	100246318	17.0 gpm DLFC for 1" elbow	
	CV3190-200	100246319	20.0 gpm DLFC for 1" elbow	
	CV3190-250	100246320	25.0 gpm DLFC for 1" elbow	
8	CV3008-04	100243824	FTG Drain 1" Strt No/Silencer	1

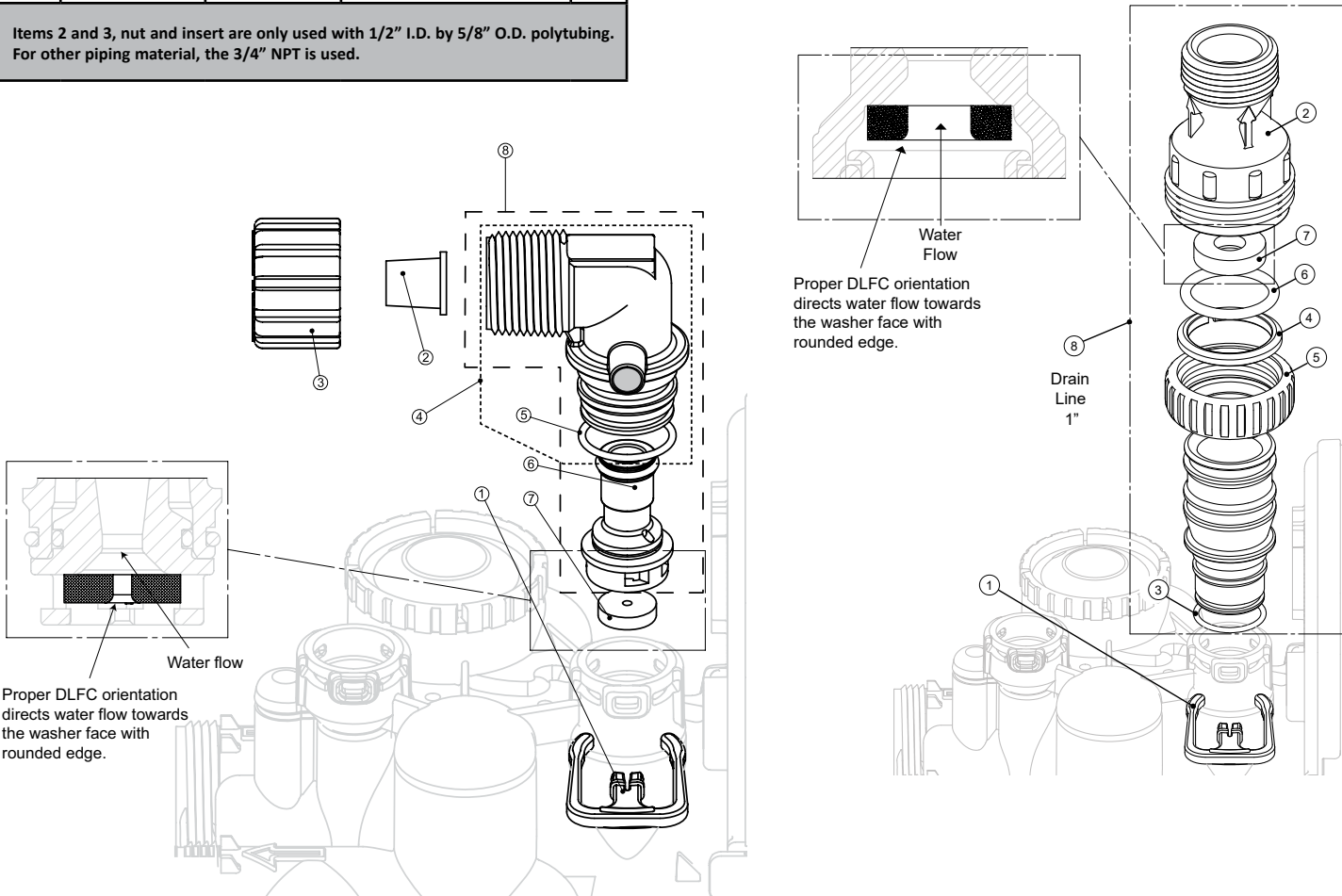

REPLACEMENT PARTS

BRINE TANK ASSEMBLY (EV)

Item #	Legacy Part #	Current Part #	Description	Qty.
1	CG2191-92	100245811	Brine tank cover, injection molded EV	1
2	CH1095-01	100245856	Optional 18" diameter salt grid	1
	CH1080	100245853	Optional 24" diameter salt grid	1
3	BT1833-1A	100245568	18" x 33" brine tank assembly	1
	BT1840-1A	100245574	18" x 40" brine tank assembly	1
	BT2441-1A	100245576	24" x 41" brine tank assembly	1
4	CH1030-29S	100245837	4" x 29" slotted brine well (18 x 33 BT)	1
	CH1030-36S	100245841	4" x 36" slotted brine well (18 x 40, 24 x 40 BTs)	1
5	CH1018	100245836	2 piece overflow set	1
6	CH4500-48	100245857	474 air check assembly, 1/2" x 48"	1
7	CH4600-50	100245860	474 safety brine valve w/ .5 gpm flow control	1
8	CH7016	100245880	Cap 4" brine well	1
9	CH4626	100245864	Nut safety brine valve stand off	1
Assemblies				
10	CH4700-29WR-1	100244899	.5 gpm safety float assembly, 18" x 33"	
	CH4700-36.5WR-1	100245872	.5 gpm safety float assembly, 18" x 40"	

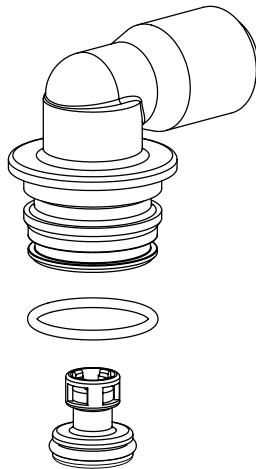
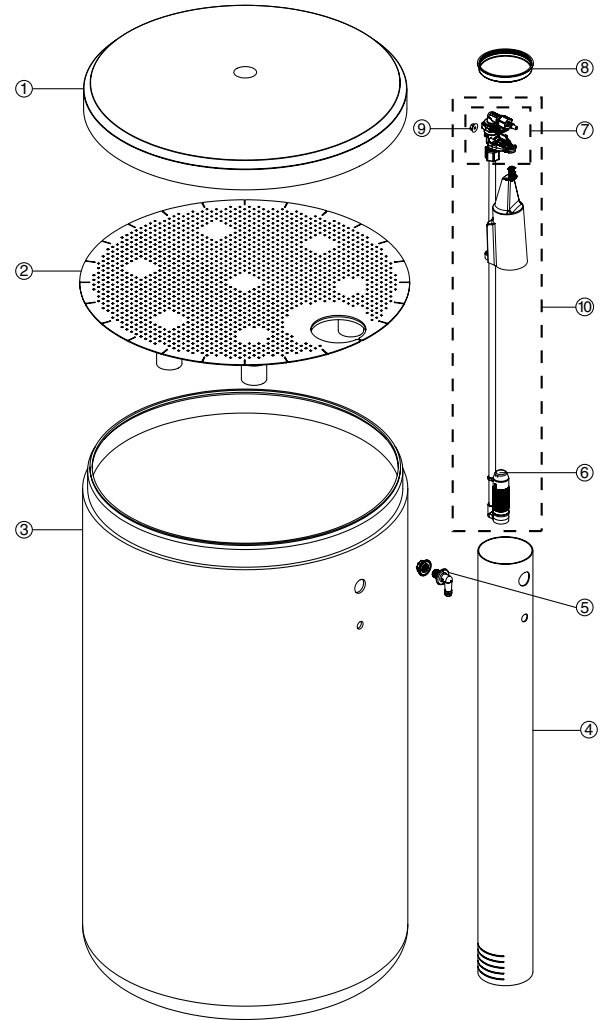

SAFETY FLOAT BRINE ELBOW

Item #	Legacy Part #	Current Part #	Description	Qty.
	CV4144	100245015	3/8" elbow cap, Parker fitting (no flow control)	1
	CV4144-03	100242646	3/8" elbow cap, Parker fitting (w/flow control)	1
	CH4612	100245861	1/2" elbow cap	1

INSTALLATION FITTING ASSEMBLIES

Fitting Installation Instructions

- Installation fittings are designed to accommodate minor plumbing misalignments, but are not designed to support the weight of a system or the plumbing.
- Slide nut on first, then the split ring and O-ring.
- Hand tighten the nut only.

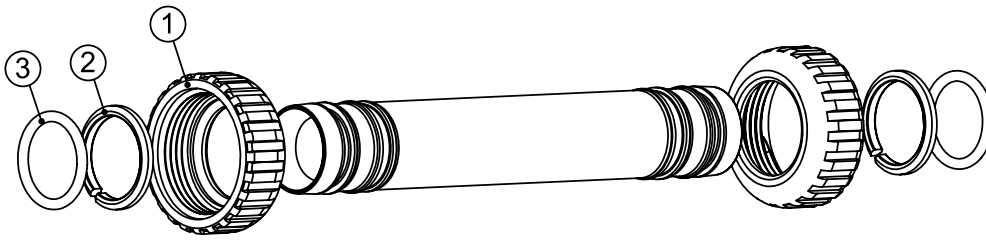

INTERCONNECT FITTING ASSEMBLY (UP TO 10" TANKS)

Item #	Legacy Part #	Current Part #	Description	Qty.
	CV4017-01	100246436	Interconnect kit for tanks up to 10"	1
1	CV3151	100246287	Nut, 1" QC	4
2	CV3150	100246286	Split ring	4
3	CV3105	100246272	O-ring 215	4

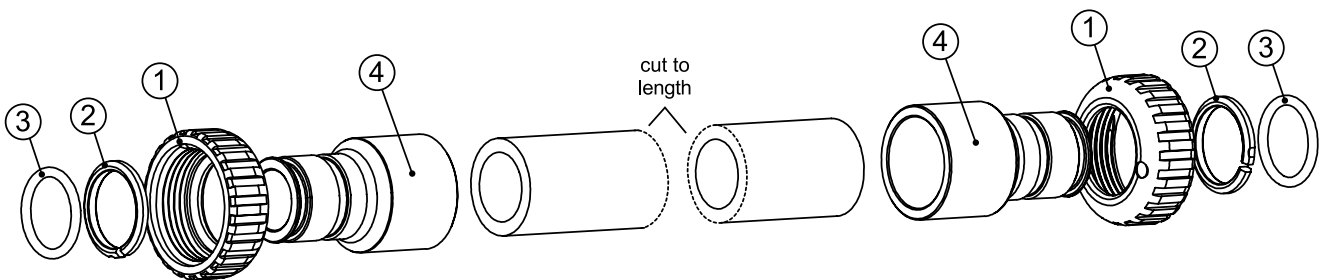

INTERCONNECT FITTING ASSEMBLY (12" & LARGER TANKS)

Item #	Legacy Part #	Current Part #	Description	Qty.
	CV4052-01	100246445	Interconnect kit for tanks 12" and larger	1
1	CV3151	100246287	Nut, 1" QC	4
2	CV3150	100246286	Split ring	4
3	CV3105	100246272	O-ring 215	4
4	CV3352	100244126	1-1/4" & 1-1/2" PVC solvent fitting	4

INSTALLATION FITTING ASSEMBLIES

NOTE: Not all available fittings are displayed below. Contact manufacturer for optional fittings.

For All Assemblies

Item #	Legacy Part #	Current Part #	Description	Qty.
1	CV3151	100246287	Nut, 1" quick connect	2
2	CV3150	100246286	Split ring	2
3	CV3105	100246272	O-ring 215	2

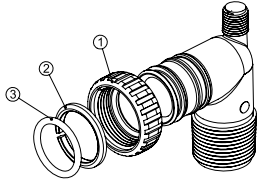

1" PVC MALE NPT ELBOW			
Legacy Part #	Current Part #	Description	Qty.
CV3007	100246197	1" PVC male NPT elbow assembly	2

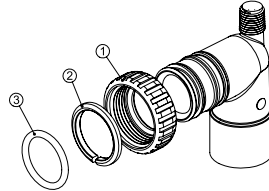

3/4" & 1" PVC SOLVENT ELBOW			
Legacy Part #	Current Part #	Description	Qty.
CV3007-01	100246198	3/4" & 1" PVC solvent elbow assembly	2

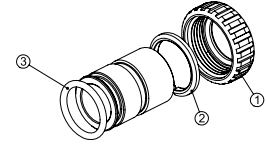

1" BRASS SWEAT			
Legacy Part #	Current Part #	Description	Qty.
CV3007-02	100246199	1" brass sweat assembly	2

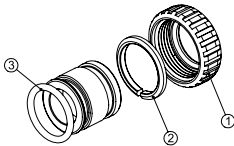

3/4" BRASS SWEAT			
Legacy Part #	Current Part #	Description	Qty.
CV3007-03	100249846	3/4" brass sweat assembly	2

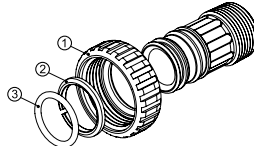

1" PLASTIC MALE NPT			
Legacy Part #	Current Part #	Description	Qty.
CV3007-04	100249846	1" plastic male NPT assembly	2

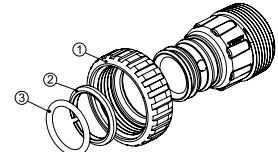

1-1/4" PLASTIC MALE NPT			
Legacy Part #	Current Part #	Description	Qty.
CV3007-05	100243921	1-1/4" plastic male assembly	2

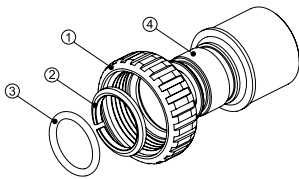

1-1/4" & 1-1/2" BRASS SWEAT			
Legacy Part #	Current Part #	Description	Qty.
CV3007-09	100243922	1-1/4" & 1-1/2" brass sweat assembly	2

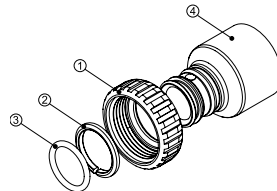

1-1/4" & 1-1/2" PVC SOLVENT			
Legacy Part #	Current Part #	Description	Qty.
CV3007-07	100243375	1-1/4" & 1-1/2" PVC solvent assembly	2

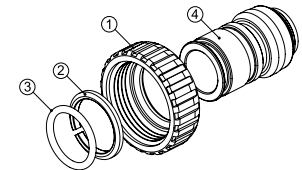

3/4 BRASS SHARK BITE			
Legacy Part #	Current Part #	Description	Qty.
CV3007-12	100249847	3/4" brass shark bite assembly	2

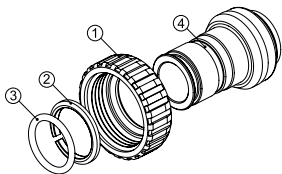

1" BRASS SHARK BITE			
Legacy Part #	Current Part #	Description	Qty.
CV3007-13	100249848	1" brass shark bite assembly	2

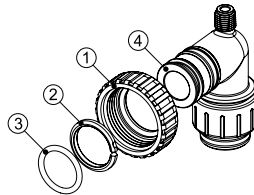

3/4" JOHN GUEST ELBOW			
Legacy Part #	Current Part #	Description	Qty.
CV3007-15	100246200	3/4" john guest elbow assembly	2

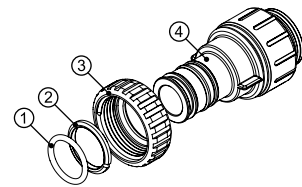

1" JOHN GUEST			
Legacy Part #	Current Part #	Description	Qty.
CV3007-17	100245045	1" john guest assembly	2

This page intentionally left blank.

EVOLVE TWIN CONDITIONER SPECIFICATIONS:

EV1-TW Specifications

MODEL		EV1-1044TW	EV1-1054TW	EV1-1354TW
¹Capacity:* (Grains/Lbs. NaCl)	Minimum	7,300 @ 3.2	16,400 @ 6.1	28,300 @ 9.5
	Medium	11,400 @ 9.3	20,700 @ 12.4	33,600 @ 15.9
	Maximum	11,800 @ 12.4	22,600 @ 15.9	36,900 @ 21.2
Amount of Media (Cu.Ft.)		1.0	1.5	2.5
Maximum Water Hardness (GPG)		20	30	40
²Maximum Iron and Manganese (PPM)		8.0	10.0	15.0
³Minimum pH		6.5	6.0	6.0
⁴Total pH Adjusted Water		510	510	863
⁵Peak Flow Rate (GPM @ P-PSI)		19.0 @ 8.3	17.0 @ 7.8	19.0 @ 7.6
Continuous Flow Rate (GPM @ P-PSI)		9.0 @ 2.4	9.0 @ 2.8	9.0 @ 2.7
Water Pressure Range (PSI)		25-100	25-100	25-100
Water Temp. (°F)		33-100	33-100	33-100
Electrical Requirements (volts-hertz)		110-50/60	110-50/60	110-50/60
Pipe Size		1"	1"	1"
Total Dimensions:	Media Tank + Valve	29"W x 52"H	29"W x 62"H	31"W x 62"H
	Brine Tank	18"W x 33"H	18"W x 33"H	18"W x 40"H

EV2-TW Specifications

MODEL		EV2-1044TW	EV2-1054TW	EV2-1354TW
¹Capacity:* (Grains/Lbs. NaCl)	Minimum	11,100 @ 3.2	22,900 @ 6.1	28,200 @ 9.3
	Medium	19,100 @ 9.3	32,000 @ 12.4	48,300 @ 15.9
	Maximum	20,300 @ 12.4	34,800 @ 15.9	60,300 @ 26.5
Amount of Media (Cu.Ft.)		1.0	1.5	2.5
Maximum Water Hardness (GPG)		40	60	80
²Maximum Iron and Manganese (PPM)		8.0	10.0	15.0
³Minimum pH		7.0	7.0	7.0
⁴Total pH Adjusted Water		N/A	N/A	N/A
⁵Peak Flow Rate (GPM @ P-PSI)		19.0 @ 9.3	17.0 @ 9.1	19.0 @ 8.6
Continuous Flow Rate (GPM @ P-PSI)		9.0 @ 3.0	8.0 @ 3.7	9.0 @ 2.8
Water Pressure Range (PSI)		25-100	25-100	25-100
Water Temp. (°F)		33-100	33-100	33-100
Electrical Requirements (volts-hertz)		110-50/60	110-50/60	110-50/60
Pipe Size		1"	1"	1"
Total Dimensions:	Media Tank + Valve	29"W x 52"H	29"W x 62"H	31"W x 62"H
	Brine Tank	18"W x 33"H	18"W x 33"H	18"W x 40"H

¹ All Evolve water conditioners are pre-factory set at medium salting. Note: influent waters must be at least 3 GPG hardness and 80 TDS. A calcite or corosex unit may be needed for correct operation.

² Combined iron and manganese removal varies depending on the form of iron, manganese, pH and other local conditions. On waters that are pre-chlorinated or where other pre-oxidation occurs, precipitated metal oxides may form that are too fine to be filtered.

³ The pH listed is the minimum for the influent water.

⁴ Optimum pH adjustment occurs at 3.0 gpm or less at maximum salt settings. Higher flow rates will produce less pH adjusted water.

⁵ Unit not tested for capacity at these flow rates. Water quality may vary.

Cycle Times And Usage

MODEL	EV1-1044TW		EV1-1054TW		EV1-1354TW		EV2-1044TW		EV2-1054TW		EV2-1354TW	
	MIN.	GAL.	MIN.	GAL.	MIN.	GAL.	MIN.	GAL.	MIN.	GAL.	MIN.	GAL.
Backwash	12	38	12	50	12	90	12	38	12	50	12	62
Brine & Rinse	72	29	90	36	90	72	72	29	90	36	90	72
Rapid Rinse	4	14	4	16	4	28	4	12	4	14	4	20
Brine Refill	6	3	10	5	12	6	6	3	10	5	12	6
Total	94	84	116	107	118	196	94	82	116	105	118	160



EVOLVE TWIN SOFTENER SPECIFICATIONS:

EVR/EVRS Specifications

MODEL		EVR-844TW EVRS-844TW	EVR-1044TW EVRS-1044TW	EVR-1054TW EVRS-1054TW	EVR-1354TW EVRS-1354TW	EVR-1465TW EVRS-1465TW	EVR-1665TW EVRS-1665TW
Capacity: (Grains/Lbs. NaCl)	Minimum	15,600 @ 3.0	23,600 @ 6.0	35,400 @ 9.0	53,000 @ 12.0	60,000 @ 18.0	80,000 @ 24.0
	Medium	21,600 @ 6.0	28,400 @ 9.0	44,400 @ 15.0	64,200 @ 18.0	75,000 @ 30.0	100,000 @ 40.0
	Maximum	25,600 @ 9.0	32,000 @ 15.0	48,800 @ 21.0	72,800 @ 24.0	90,000 @ 45.0	120,000 @ 60.0
Amount of Resin Media (Cu. Ft.)		.85	1.0	1.5	2.5	3	4
Maximum Water Hardness (GPG)		50	75	100	100	100	100
Minimum pH Required		7.0	7.0	7.0	7.0	7.0	7.0
Peak Flow Rate (GPM @ P-PSI)		11.4 @ 15.0	17.1 @ 15.0	14.3 @ 15.0	18.5 @ 15.0	27.0 @ 25.0	29.0 @ 25.0
Continuous Flow Rate (GPM @ P-PSI)		5.0 @ 5.4	5.0 @ 2.8	5.0 @ 3.8	5.0 @ 2.4	20.0 @ 15.0	22.0 @ 15.0
Water Pressure Range (PSI)		30-100	30-100	30-100	30-100	30-100	30-100
Water Temperature (°F)		33-100	33-100	33-100	33-100	33-100	33-100
Electrical Requirements (volts-hertz)		110-50/60	110-50/60	110-50/60	110-50/60	110-50/60	110-50/60
Pipe Size		1"	1"	1"	1"	1"	1"
Total Dimensions:	Media Tank and Valve	27"W x 52"H	29"W x 52"H	29"W x 62"H	31"W x 62"H	32"W x 74"H	34"W x 74"H
	Brine Tank	18"W x 33"H	18"W x 33"H	18"W x 33"H	18"W x 40"H	18"W x 40"H	24"W x 41"H

NOTE: Only the -844TW through the -1354TW sizes are approved in the state of Wisconsin.

EVRC-TW/EVRC-S-TW Specifications

MODEL		EVRC-1054TW EVRC-S-1054TW	EVRC-1354TW EVRC-S-1354TW
Capacity: (Grains/Lbs. NaCl)	Minimum	23,600 @ 6.0	35,400 @ 9.0
	Medium	28,400 @ 9.0	44,400 @ 15.0
	Maximum	32,000 @ 15.0	48,800 @ 21.0
Amount of Resin Media (Cu. Ft.)		1.0	1.5
Amount of Carbon Media (Cu. Ft.)		.5	1.0
Maximum Water Hardness (GPG)		75	100
Minimum pH Required		7.0	7.0
Peak Flow Rate (GPM @ P-PSI)		14.3 @ 15.0	18.5 @ 15.0
Continuous Flow Rate (GPM @ P-PSI)		5.0 @ 3.8	5.0 @ 2.4
Water Pressure Range (PSI)		30-100	30-100
Water Temp. (°F)		33-100	33-100
Electrical Requirements (volts-hertz)		110-50/60	110-50/60
Pipe Size		1"	1"
Total Dimensions:	Media Tank and Valve	29"W x 62"H	31"W x 62"H
	Brine Tank	18"W x 33"H	18"W x 40"H



¹All water softeners are factory preset at medium salting.

²The pH listed is the minimum for the influent water.

³Unit not tested for capacity at these peak flow rates. Water quality may vary.

Cycle Times and Salt Usage

MODEL	EVR-844TW EVRS-844TW	EVR-1044TW EVRS-1044TW	EVR-1054TW EVRS-1054TW	EVR-1354TW EVRS-1354TW	EVR-1465TW EVRS-1465TW	EVR-1665TW EVRS-1665TW	EVRC-1054TW EVRC-S-1054TW	EVRC-1354TW EVRC-S-1354TW
Backwash	6	8	8	10	12	12	8	10
Brine & Rinse	40	60	90	90	90	90	90	90
Rinse	4	4	4	4	4	4	4	4
Brine Refill	4	6	10	12	20	27	6	10
Regenerant (lbs.)	6	9	15	18	30	40	9	15
Total (min.)	54	78	112	116	126	133	108	114



Evolve Series® Water Conditioner and Softener Limited Warranty

Congratulations. You have purchased one of the finest water treatment systems available. In the unlikely event of a problem due to defects in material and workmanship, Water-Right® proudly warrants our Evolve Series® water conditioners and softeners to the original owner, at original installation location, when installed in accordance with Water-Right specifications from the date of original installation as follows:

- For the LIFETIME of the original owner:** Media tank, except for damages due to freezing, high pressure (120 PSI and above), extreme temperature (100° F and above) or a vacuum on the system.
- For a period of TEN YEARS:** Brine tank.
- For a period of FIVE YEARS:** Complete valve.
- For a period of ONE YEAR:** All other parts and components.

Any part found defective within the terms of this warranty will be repaired or replaced by the dealer at the manufacturer's discretion. You pay only freight from our factory and local dealer charges. To obtain local warranty service, contact original dealer. If original dealer is unknown, contact Water-Right for authorized service dealer in your area. If no authorized dealer is located in your area, please ship defective part or component freight prepaid to:

Water-Right, Inc.
1900 Prospect Ct.
Appleton, Wisconsin 54914

Water-Right, at its discretion, will repair or replace the part or component at its expense and return part freight collect.

The above provisions of the warranty are valid as long as the unit is connected in compliance with local plumbing codes and in an equivalent manner and condition of the original installation and is owned by the original owner.

This warranty does not cover expendable or misapplied medias, or damages due to accident, fire, flood, freezing, or any other Act of God. Water-Right is not responsible for damages due to change in water conditions, misapplication, misuse, neglect, vacuum, oxidizing agents, alteration, or lack of maintenance. No responsibility is assumed for loss of use of the unit, inconvenience, loss or damage to real or personal property or any incidental or consequential damages. Furthermore, we assume no liability and extend no warranties, express or implied, for the use of this product with a non-potable water source. **To the extent permitted by law, Water-Right disclaims all implied warranties, including without limitation warranties of merchantability and fitness for particular purpose; to the extent required by law, any such implied warranties are limited in duration to the period specified above for the specified components.**

Some states do not allow limitations on how long an implied warranty lasts, so the above limitation may not apply to you. Some states do not allow the exclusion or limitation of incidental or consequential damages, so the above limitation or exclusion may not apply to you. This warranty gives you specific legal rights, and you may also have other rights which vary from state to state.

QUICK REFERENCE GUIDE:

GENERAL OPERATION

When the system is operating, one of six displays will be shown:

1. Time of day/gpm
2. Flow rate
3. Vacation mode
4. Capacity remaining
5. Days to a regen
6. Dealer name and phone number

Pressing **NEXT** will toggle between the six choices.

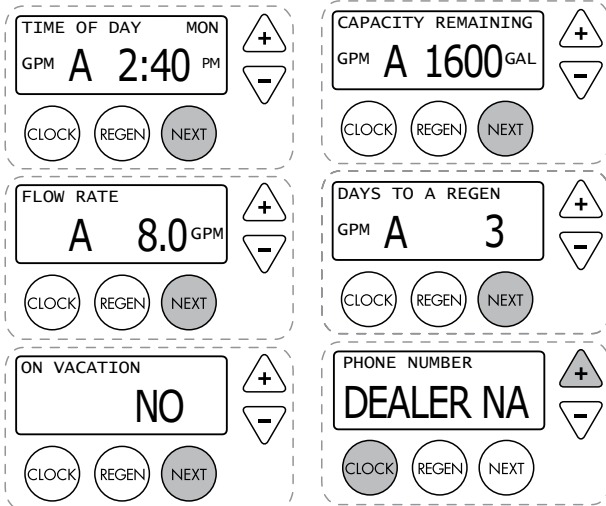

MANUAL REGENERATION

NOTE: For softeners, if brine tank does not contain salt, fill with salt and wait at least two hours before regeneration. If you need to initiate a manual regeneration immediately, press and hold **REGEN** until valve motor starts (typically 3 seconds).

REGEN TODAY and TIME OF DAY will flash alternately if a regeneration is expected tonight.



ERROR

If the display toggles between "Error" and an error code (i.e. a number), call a service technician and report the error code.



BYPASS VALVE OPERATION

To shut off water to the system, position arrow handles as shown in the bypass operation diagram below. If your valve doesn't look like the diagram below, contact your service technician for instructions on how to shut off water.

NORMAL OPERATION

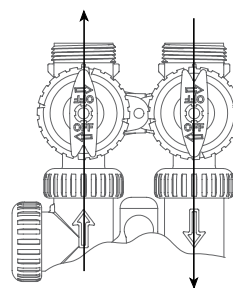

BYPASS OPERATION

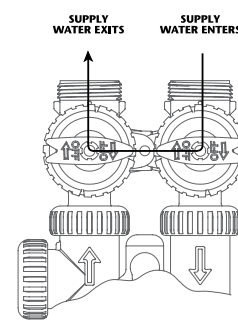

TO SET TIME OF DAY

In the event of a prolonged power outage, time of day flashes, indicating that this needs to be reset. All other information will be stored in memory no matter how long the power outage.

1. Accessed by pressing **CLOCK**
2. Adjust hours with + and — buttons, AM/PM toggles at 12
3. Press **NEXT**
4. Adjust minutes with + and — buttons
5. Press **NEXT**
6. Adjust current day with + and — buttons
7. Press **NEXT** to complete and return to normal operation

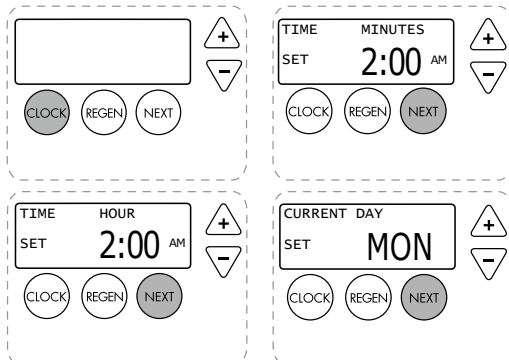

QUICK REFERENCE GUIDE:

ADJUST HARDNESS, DAYS BETWEEN REGENERATION, TIME OF REGENERATION AND ALARM BUZZER

For initial set-up or to make adjustments, please complete the following steps.

1. Accessed by pressing **NEXT** and + button simultaneously
2. Adjust hardness using + and — buttons
3. Press **NEXT**
4. Adjust days between regenerations or number of times per day using + and — buttons
5. Press **NEXT**
6. Manufacturer has set regeneration to occur when zero gallons remain.
7. Press **NEXT**
8. Turn service alarm by gallons ON with + and — buttons. Default is OFF.
9. Press **NEXT**
10. Turn service alarm by time ON with + and — buttons. Default is OFF.
11. Press **NEXT** three times
12. Turn alarm buzzer ON or OFF with + and — buttons.
13. Press **NEXT**
14. Adjust alarm buzzer start time with + and — buttons.
15. Press **NEXT**
16. Adjust alarm buzzer end time with + and — buttons.
17. Press **NEXT**
18. Turn display backlight ON or OFF with + and — buttons. Default is ON.
19. Press **NEXT** to complete and return to normal operation.

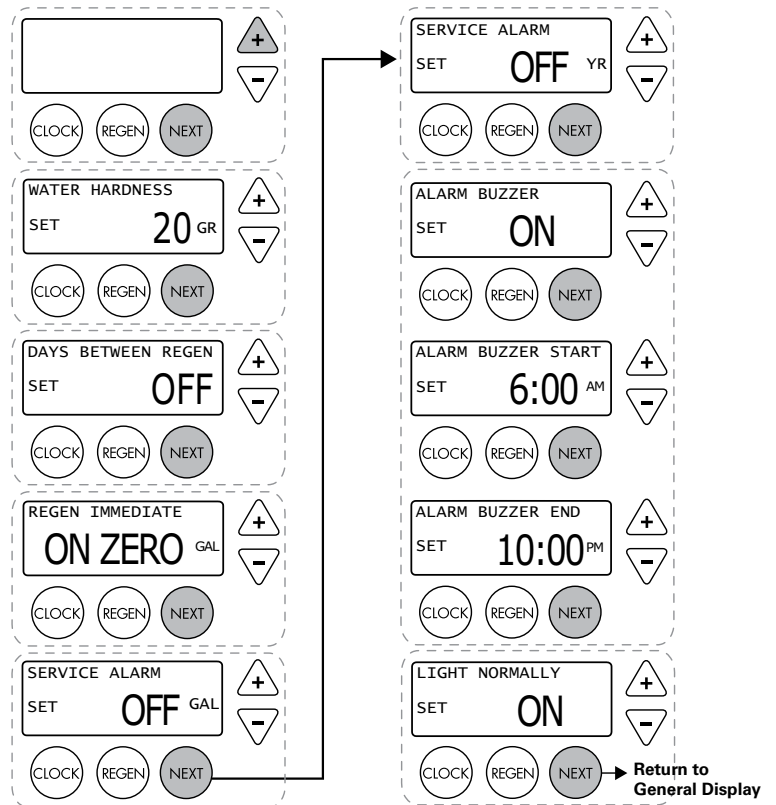



Manufactured exclusively for Evolve Dealers at:
1900 Prospect Court • Appleton, WI 54914
Phone: 920-739-9401 • Fax: 920-739-9406



Love your Evolve Twin
Conditioner or Softener?
Scan the QR code above with
your mobile device to leave
a review.