



CLICK ANYWHERE on THIS PAGE to RETURN to AAV AIR ADMITTANCE VALVES - STUDOR VENTS at [InspectApedia.com](https://www.inspectapedia.com)



AIR ADMITTANCE VALVES

THE TRUSTED LINK
SINCE 1921

Durgo Air Admittance Valves for drainage systems

For a drainage system to function optimally it has to be correctly designed and ventilated. Pressure changes that arise in the system during use could otherwise empty the water traps and cause bad odours and dampness. Venting is traditionally done by a ventilation pipe through the roof. When Durgo presented its Air Admittance Valve (AAV) in 1974 it triggered a revolution in drainage installations the world over. Today the valves are a natural part of any drainage system.

The valve is installed straight on to the waste pipe, thus avoiding a hole in the roof that costs time and money, and which could begin to leak and cause damp and other damage to the building.

The valve opens at negative pressure. This lets air into the system, which equalises the pressure and stops the water being sucked out of the water traps. At normal or overpressure the valve is closed and tight, preventing foul air from leaking out into the building.

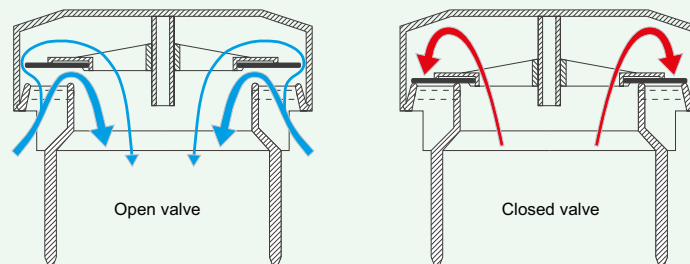

Installation

Overpressure could arise in a drainage system when the contents in a vertical stack transfer into the horizontal drain. This overpressure cause strong odours to force their way through water traps and could also cause water damage if the sewage pushes up through a floor drain or WC. The problem could occur regardless of whether the system is open end or is fitted with an AAV. This can be remedied with one or more of the following measures:

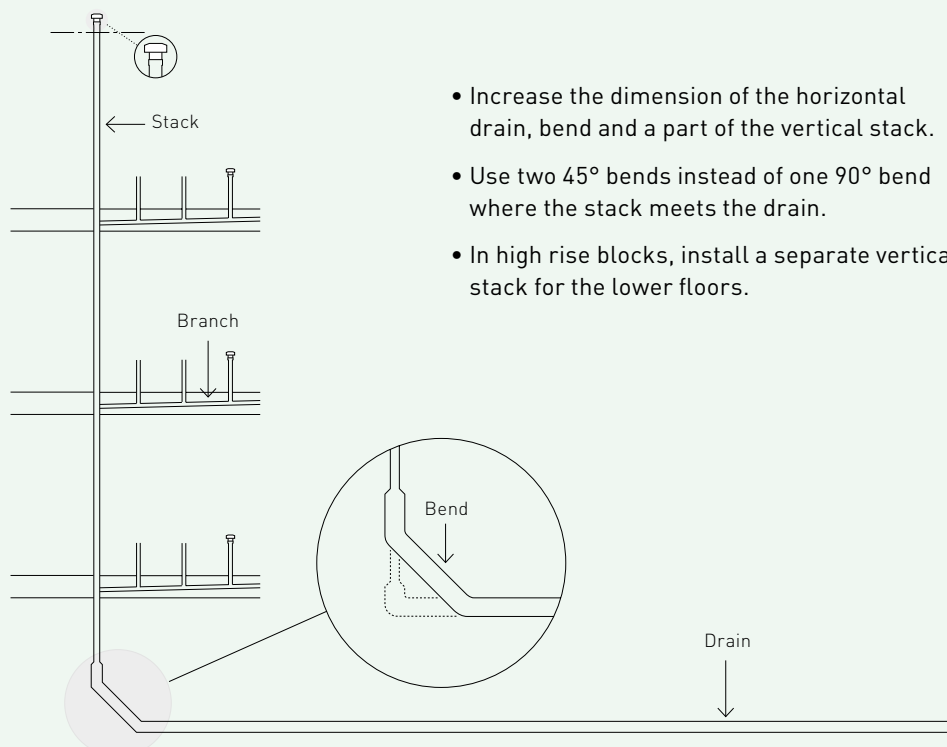

Secondary venting

Secondary venting can be used to increase the capacity and/or reduce the dimension of the horizontal branch pipe. It is important that the entire horizontal pipe is thoroughly flushed. There should always be at least one discharge unit outside the venting pipe connection to avoid the risk of blockages.

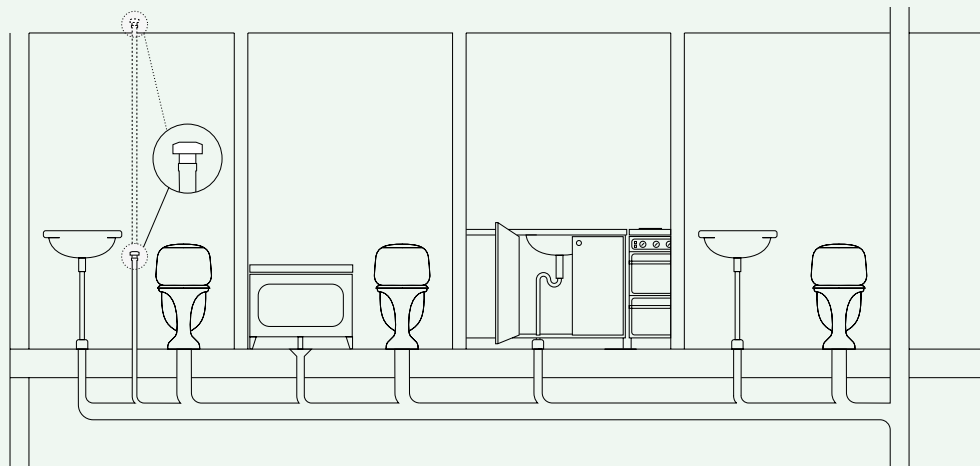

Blockage warning signs

The Durgo Air Admittance Valve also indicates upcoming blockages in the drainage system. If the water level in the toilet bowl is higher than normal or if the water in a floor drain or hand basin is sinking slowly then it could be a sign of a blockage in the waste pipe. When flushing or draining, liquid flows into the drainage pipe system. As the AAV seals against overpressure, the liquid cannot run freely in the pipe if there is a blockage downstream cutting off the connection with an air-vented pipe. This warning sign enables measures to be taken before the blockage is total.

Capacity / Dimensioning

The Durgo Air Admittance Valves are reliable and has a high air flow capacity. The entire range of AAVs are manufactured, tested and CE labelled in compliance with EN 12380. Durgo air admittance valves come in a wide range of sizes to fit the most common waste pipe dimensions. The valve model and dimension is chosen based on the calculated venting needs. The AAVs are tested to function in installations where the temperature is -20°C to +60° and should be installed within easy reach for inspections and any need for cleaning. The air admittance valve can, depending on model, be placed up to a metre below an installed unit (WC, washbasin etc.).

As well as the dimensions given in the table, Durgo AAVs come in various other sizes designed for international markets and also older system types.

A complete table of dimensions is available at www.durgo.se

Model	Dimension (mm)			With polystyrene hood		Capacity l/s at -250 Pa	Standard in compliance with EN 12380
	Connection	D	H	D	H		
AAV-G15	G15	54	48			3.0	A1
AAV-G20	G20	54	53			5.6	A1
AAV-G25	G25	54	53			7.5	A1
AAV-32	32	54	61			6.9	A1
AAV-40	40	70	77			13.0	A1
AAV-50JR	50	70	77			12.0	A1
AAV-50	50	84	96	120	120	17.0	A1
AAV-75	75	118	107	155	133	37.0	A1
AAV-90	90	140	121	180	144	48.1	A1
AAV-110	110	140	124	180	147	44.2	B1
AAV-140	140	211	148	250	163	103.7	B1
AAV-160/140	160	211	150	250	165	103.7	B1
	d	W	L	H1	H2		
AAV-48P	48	54.5	124	90	66.5	19.2	A1
AAV-50P	50	54.5	124	90	66.5	19.2	A1

Class A1 AAVs can be installed up to 1 m below the water level of an installed unit (WC, washbasin etc.).

The AAVs can be installed in places with temperatures of -20° to +60°C and be accessible for inspection and any need for cleaning.

When installed in cold places the polystyrene hood should be mounted on the valve.

Durgo AAVs are manufactured, tested and CE labelled in compliance with EN 12380.

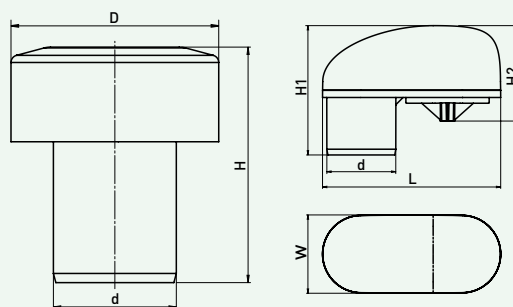

Dimensioning in accordance with EN 12056

When dimensioning and designing wastewater installations with gravity drainage systems, one can refer to the European standard EN 12056 Parts 1 to 5.

To determine a suitable dimension for the air admittance valve, the total flow rate in the system needs to be calculated.

The total flow rate is calculated based on the discharge unit flow rate for the installed appliances and the system usage of appliances, frequency factor [K].

The discharge unit flow [DU] for installed appliances in accordance with EN 12056 system type 2 with 70% filling degree.

Appliance	Discharge Units [DU] (l/s)
Kitchen Sink, Slop Sink	0.6
Shower unit with bottom plug	0.5
Shower unit without bottom plug	0.4
Floor drain DN50-DN70	0.9
Floor drain DN100	1.2
Household dishwasher	0.6
Washing machine ≤ 12 kg	1.2
Washing machine ≤ 6 kg	0.6
Washbasin & bidet	0.3
Urinal (per person)	0.2
Urinal with cistern (single)	0.5
Urinal with flushing valve (single)	0.8
WC 4.0–7.5l cistern	1.8
WC 9.0l cistern	2.0

Frequency factors [K] in accordance with EN 12056

Usage of appliances	[K]
Intermittent use, e.g. home, office	0.5
Frequent use, e.g. hospitals, schools, restaurants, hotels	0.7
High frequency use, e.g. public toilets and showers	1
Special premises, e.g. laboratories	1.2

The expected wastewater flow [Q_{ww}] is calculated based on the frequency factor [K]

$$Q_{ww} = K \sqrt{\sum DU} \text{ (l/s)}$$

The total flowrate [Q_{tot}] is calculated by adding the potential continuous, [Q_c], and pumped, [Q_p], discharge rates.

$$Q_{tot} = Q_{ww} + Q_c + Q_p \text{ (l/s)}$$

The minimum air flow capacity of the air admittance valve [Q_a] when installed on a ventilated branch pipe is $2 \times Q_{tot}$

The minimum air flow capacity of the air admittance valve [Q_a] when installed on a ventilated vertical stack is $8 \times Q_{tot}$

Calculation example

Calculation example of the total flowrate and air admittance valve dimensions in a 3-storey apartment building.

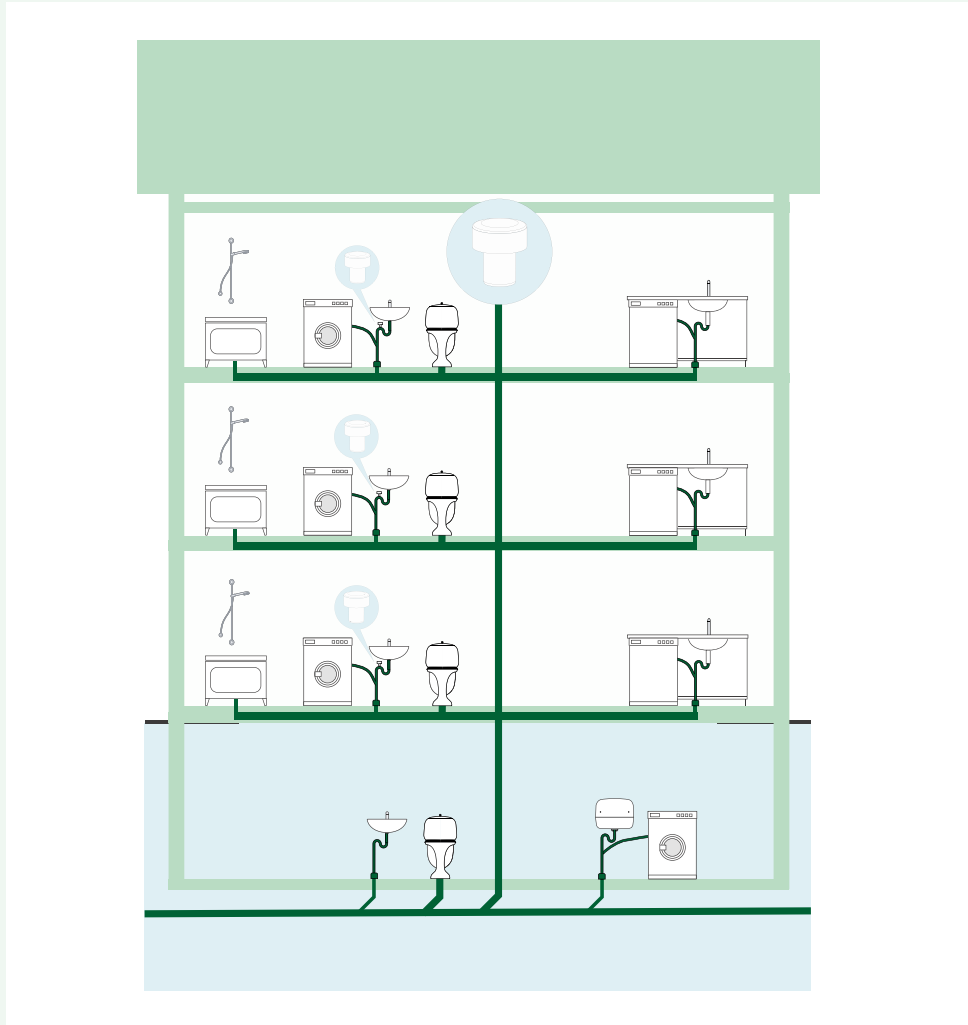

Ventilated stack – Connected appliances

Appliance	Number	Discharge Unit, [DU] (l/s)	\sum DU
Bathtub (own water trap)	3	0.6	1.8
Washing machine \leq 12kg	4	1.2	4.8
Washbasin	4	0.3	1.2
WC 4.0–7.5l cistern	4	1.8	7.2
Household dishwasher	3	0.6	1.8
Kitchen Sink, Slop Sink	4	0.6	2.4
Sum of discharge Units [DU]			19.2

Frequency factor for the building [K]=0.5

No continuous or pumped discharge rates $[Q_c]=0$ l/s, $[Q_p]=0$ l/s

Expected wastewater flow, $Q_{ww} = K\sqrt{\sum DU} = 0.5 \sqrt{19.2} = 2.19$ l/s

Total flowrate, $Q_{tot} = Q_{ww} + Q_c + Q_p = 2.19$ l/s

$Q_a = Q_{tot} \times 8 = 2.19 \times 8 = 17.5$ l/s

The minimum air flow capacity on an air admittance valve installed on a vertical stack pipe is 17.5 l/s.

The Durgo air admittance valve DN75 with 37 l/s air flow capacity can be used for venting the stack pipe.

Ventilated stack – Connected appliances

Appliance	Number	Discharge Unit, [DU] (l/s)	Σ DU
Bathtub (own water trap)	1	0.6	0.6
Washing machine \leq 12 kg	1	1.2	1.2
Washbasin	1	0.3	0.3
WC 4.0–7.5l cistern	1	1.8	1.8
Sum of Discharge Units [Σ DU]			3.9

Frequency factor for the building [K]=0.5

No continuous or pumped flows, $[Q_c]=0$ l/s, $[Q_p]=0$ l/s

Expected wastewater flow, $Q_{ww}=K\sqrt{\Sigma DU}=0.5\sqrt{3.9}=0.99$ l/s

Total flowrate, $Q_{tot}=Q_{ww}+Q_c+Q_p=0.99$ l/s

$Q_a=Q_{tot}\times 2=0.99\times 2=1.98$ l/s

The minimum air flow capacity on an air admittance valve installed on a branch pipe is 1.98 l/s

The Durgo air admittance valve DN15 with 3 l/s air flow capacity is sufficient for venting the branch pipe.

Durgo original

When Durgo presented its Air Admittance Valve in 1974 it triggered a revolution in drainage installations the world over. Today air admittance valves are a standard part of drainage systems. Our original design paved the way for a reliable, high capacity air admittance valve. A simple and reliable design with an ABS plastic housing and a unique patented EPDM rubber seal.

High rise or bungalow, large or small, Durgo has an air admittance valve that fits. Millions of Durgo Air Admittance Valve are installed in buildings and plants the world over, an unparalleled quality assurance.



DURGO

THE TRUSTED LINK

SINCE 1921

DURGO – TOP QUALITY RIGHT DOWN TO THE FINEST DETAIL

Because Durgo's products are vital parts of a larger system, we always strive to be the strongest link in the chain. As we have done since 1921. Our craftsmanship tradition is close to our hearts, but only in combination with modern technology can we guarantee compliance with the highest demands on safety and quality. That is the secret behind the renowned Durgo quality.

DURGO AB
BOX 3021, SE-169 03 SOLNA, SWEDEN
RÅSUNDAVÄGEN 25, SE-169 67 SOLNA, SWEDEN
PHONE +46 8 730 5280, FAX +46 8 735 6955
SALES@DURGO.SE
WWW.DURGO.SE