

CLICK ANYWHERE on THIS PAGE to return to CULLIGAN WATER SOFTENER
MANUALSat InspectApedia.com

**How to get the most enjoyment, economy and efficiency
from your new Culligan Water Conditioner.**

Culligan[®]

**CULLIGAN[®] MARK
89 AND 812
AUTOMATIC WATER
CONDITIONERS**

**USE AND
CARE GUIDE**

Thank you . . .

**AND WELCOME TO YOUR NEW WORLD OF BETTER
LIVING WITH CULLIGAN WATER.**

If this is your first experience having soft, conditioned water in your home, you'll be amazed at the marvelous difference it makes. We promise that you'll never want to be without it again.

Congratulations, too, on selecting one of the "first family" of water conditioners in the prestigious Culligan® Mark Series.

We hope you will become familiar with this Guide so that you will better understand how your new appliance works and how you can help it give you the many benefits of softened, conditioned water.

The Culligan Mark 89 and 812 water conditioners are listed by the NSF International under Standard 44 for the reduction of calcium and magnesium (the hardness minerals).

INDEX

PAGE

Specifications	3
Getting All the Benefits of Conditioned Water	4,5
About Your Culligan Mark Series Water Conditioner	6
How Your Water Conditioner Works	7
When and How to Make Adjustments	8-10
Salt Supply, Usage and Service	11
Care and Cleaning of Your Water Conditioner	12, 13
Things to Check Before You Call for Service	14, 15
When and How to Bypass Your Water Conditioner	16, 17
Important Records	18, 19

SPECIFICATIONS

CULLIGAN® MARK 89 and MARK 812 WATER CONDITIONERS

MODEL 89 WITH TIME CLOCK

MODEL 812 WITH TIME CLOCK

Control Valve Type	5-Cycle, Reinforced Thermoplastic	5-Cycle, Reinforced Thermoplastic
Overall Conditioner Height	51 in. (129.5 cm)	51 in. (129.5 cm)
Media Tank Dimensions (Dia x Ht)	9 x 45 in. (23 x 114 cm)	12 x 45 in. (30 x 114 cm)
Salt Storage Tank Dimensions (Dia x Ht)	16 x 43 in. (41 x 109 cm) or 18 x 43 in. (46 x 109 cm)	18 x 43 in. (46 x 109 cm)
Exchange Media, Type and Quantity	Cullex® Resin, 0.7 cu. ft. (20 litres)	Cullex Resin, 1.4 cu. ft. (40 litres)
Underbedding, Type and Quantity	Cullsans® Media, 20 lbs. (9.1 kg)	Cullsans Media, 30 lbs. (13.6 kg)
Exchange Capacity @ Salt Dosage per Recharge	15,900 grains (1030 g) @ 4.1 lbs. (1.9 kg) 19,900 grains (1289 g) @ 7.7 lbs. (3.5 kg) 20,100 grains (1302 g) @ 9.8 lbs. (4.4 kg)	27,700 grains (1795 g) @ 6.0 lbs. (2.7 kg) 38,800 grains (2514 g) @ 16.0 lbs. (7.3 kg) 38,400 grains (2488 g) @ 20.0 lbs. (9.1 kg)
Freeboard to media	18.9-19.9 in. (48-51 cm)	17.5-18.5 in. (44-47 cm)
Freeboard to Underbedding	37.2 in. (95 cm)	38.5 in. (98 cm)
Salt Storage Capacity	250 lbs. (114 kg) or 375 lbs. (170 kg)	375 lbs. (170 kg)
Rated Service Flow @ Pressure Drop	7.5 gpm @ 15 psi (30 lpm @ 1 bar)	7.5 gpm @ 15 psi (31 lpm @ 1 bar)
Total Hardness, Maximum	75 gpg (1300 mg/l)	100 gpg (1700 mg/l)
Total, Iron Maximum	5 ppm (mg/l)	5 ppm (mg/l)
Hardness to Iron Ratio, Minimum	8 gpg per 1 ppm Iron (140 mg/l per 1 mg/l Iron)	8 gpg per 1 ppm Iron (140 mg/l per 1 mg/l Iron)
Operating Pressure	20-125 psi (1.4-8.6 bar)	20-125 psi (1.4-8.6 bar)
Operating Temperature	33-120°F (1-50°C)	33-120°F (1-50°C)
Electrical Requirements	120 Volts AC, 60 Hz	120 Volts AC, 60 Hz
Electrical Consumption, Min/Max	3 Watts/35 Watts	3 Watts/35 Watts
Drain Flow, Maximum	2.0 gpm (7.6 lpm)	3.5 gpm (13.2 lpm)
Recharge Time, Average	80 minutes	85 minutes
Recharge Water Consumption, Average	64 gal. (242 litres)	110 gal. (416 litres)

IT'S ALL SO EASY, SO ECONOMICAL, SO EFFICIENT, SO ENJOYABLE!

KIND TO SKIN AND COMPLEXION

Soft water will help prevent red, itchy or dry skin because there are no hardness impurities to cause soreness, no soap curd to coat the skin. Shaving is easier, smoother - either with blade or electric shaver.

BATHING AND SHOWERING

You'll use far less soap with conditioned water. Use your soap very sparingly - not as you did before soft water. Just a quick rinse removes all lather, leaving your skin pleasantly smooth and silky - because now it's free of sticky soap curd and film.

SAVES WASHING COSTS. HELPS CONTROL ENVIRONMENTAL POLLUTION

Soft water washes whiter and cleaner with less soap or detergent. Because the hardness impurities are removed, your soap can concentrate solely on washing. People usually find that they can reduce the amount of soap they use substantially. If you normally used a cup per wash load with hard water, try using only 1/3 cup depending on the size of your wash load and the degree of soil. Different amounts are required, but you can use less with softened water. An added bonus is the fact that your washable fabrics will last longer.

SUPER HAIR CONDITIONING

Soft water is great for scalp and hair care. No insoluble deposits are formed. Hair is shinier, softer, more manageable. Reduce the amount of shampoo you have normally used.

DISHES ARE A DELIGHT

Washed by hand or in a dishwasher, glassware, dishes and silver wash cleaner, easier. Follow your dishwasher manufacturer's instructions. Soft water promotes sanitation because no greasy hard water film can form to collect or harbor bacteria.

EASIER HOUSEKEEPING, GLEAMING FIXTURES

You'll be amazed at the marvelous difference. Just a swish of the cloth, and the bathtub or shower and fixtures are clean and sparkling. Imagine, no scouring! No hard water scum to cause rings, streaks, spots and stains. To keep their gleaming luster, simply wipe fixtures with a towel after use. Formica, tile, walls, floors, woodwork surfaces clean easier, stay clean longer. You'll save on cleaning aids and save on time.

SAVES WATER-HEATING ENERGY HELPS WATER-USING APPLIANCES

Soft water reduces the formation of rock-like hard water scale which encrusts water heaters, hot water pipes, shower heads, and water-using appliances. This scale can cause premature maintenance and failure.

Elimination of hard water also provides substantial energy savings because scale acts as an insulator, wasting electricity or gas used to heat water.

SAVINGS GALORE

A water conditioner is frequently referred to as "the appliance that pays for itself". You'll find that your savings on soaps, detergents, cleaning aids, and personal care products will help your family's household budget. And if you place a price on your time, you'll be most happy with the time saved by your new family servant.

WATER FOR LAWNS AND HOUSEHOLD PLANTS

If possible, lawn sprinkling faucets should be supplied with hard water primarily because it is uneconomical to soften so much water.

Household plants are much more sensitive than lawns with respect to the kind of water which is best. First, because they receive no rainfall and, second, there is little or no drainage of the soil. Preferably they should be watered with rainwater or water which is low in mineral content such as distilled or demineralized water. Softened water is not recommended for house plants because a build-up of sodium in the soil may interfere with efficient absorption of water by the plant root system. Additional information may be obtained from your independently operated Culligan dealer.

HOW YOUR WATER CONDITIONER WORKS

Why Water Gets Hard And How It's Softened

All of the fresh water in the world originally falls as rain, snow, or sleet. Surface water is drawn upward by the sun, forming clouds. Then, nearly pure and soft as it starts to fall, it begins to collect impurities as it passes through smog and dust-laden atmosphere. And as it seeps through soil and rocks it gathers hardness, rust, acid, unpleasant tastes and odors.

Water hardness is caused primarily by limestone dissolved from the earth by rainwater. Because of this, in earlier times people who wanted soft water collected rainwater from roofs in rain barrels and cisterns before it picked up hardness from the earth.

Some localities have corrosive water. A softener cannot correct this problem and so its printed warranty disclaims liability for corrosion of plumbing lines, fixtures or appliances. If you suspect corrosion, your Culligan Man has equipment to control the problem.

CAUTION: Do not use where the water is microbiologically unsafe or with water of unknown quality without adequate disinfection before or after the unit.

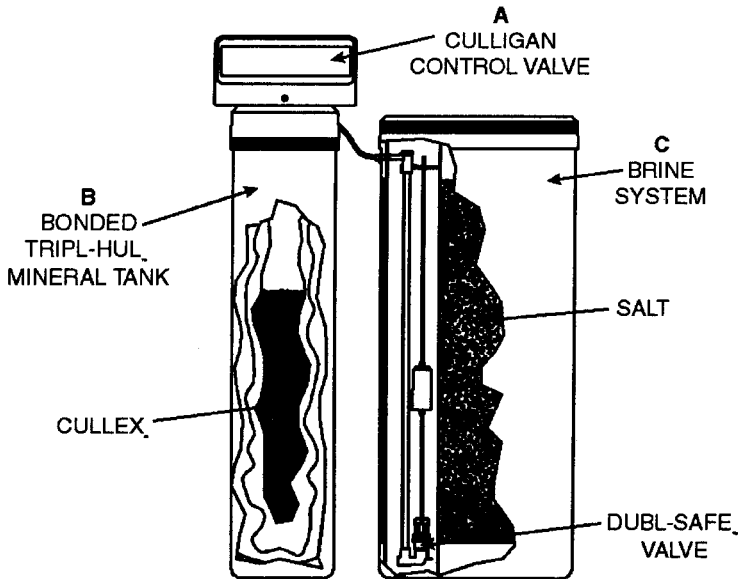

THE CULLIGAN® PROCESS

Your Culligan water conditioner consists of three basic components, (A) the Control Valve, (B) the Mineral Tank, and (C) the Brine System.

A. The exclusive Culligan control valve automatically performs a variety of tasks that are necessary for the proper operation of your water conditioner. These tasks, commonly referred to as cycles or operating positions, are: SERVICE, REGENERATION, AND BRINE REFILL.

1. **SERVICE:** While the control valve is in the "Service cycle", hard water is directed down through the column of Culex® resin where hardness minerals are removed from the water. The softened water is then directed into your household plumbing lines. The ability of the Culex resin to remove hardness minerals needs to be periodically replenished; this is referred to as . . .
2. **REGENERATION:** While the control valve is in the "Regeneration cycle", water is first directed up through the column of Culex resin to flush accumulated sediment out of the resin and down the drain. Then, the regenerant brine solution is slowly drawn from the bottom of the salt storage tank of the Brine System and is directed down through the column of Culex resin, restoring the ability of the resin to remove hardness minerals from your water supply. Once completed, the regeneration cycle is followed by . . .
3. **BRINE REFILL:** While the control valve is in the "Brine Refill cycle", a predetermined amount of water is directed to the salt storage tank of the Brine System so that additional salt can be dissolved to provide the brine solution that will be needed for the next regeneration cycle.

B. The exclusive Bonded Tripl-Hull, Mineral Tank contains the Culex resin column, Cullsán® underbedding, and an outlet manifold. Note: The Mineral Tank of Aqua-Sensor® models also contains a mineral sensor device that determines when the Culex resin needs regeneration. The number of gallons of hard water that can be softened by the Culex resin column before it needs regeneration is called the "capacity" of the resin column, and depends upon the amount of hardness minerals in each gallon of water (expressed as grains per gallon) and upon the amount of regenerant brine solution (expressed as pounds of salt) passed through the resin column during regeneration.

Your Culligan serviceworker, taking into account the hardness of your water and the amount of softened water your household may reasonably expect to use each day, has carefully established how often the softener will regenerate and how much salt will be used for each regeneration. This will ensure that all of your soft water needs will be fulfilled without using an excessive amount of salt.

C. The Brine System consists of a salt storage container and hydraulic Dubl-Safe™ valve. The salt storage container holds the salt that is used to make the regenerant brine solution. The hydraulic Dubl-Safe valve limits the amount of water that is returned to the salt storage tank during the brine refill cycle.

Since a predetermined amount of salt is dissolved with each brine refill cycle, the salt must be periodically replenished in order to maintain efficient operation. Your Culligan serviceworker will be able to tell you about how often salt must be added to the salt storage container.

HOW TO MAKE ADJUSTMENTS TO THE TIMER MECHANISM

An Adjustment Is Needed When:

- 1** you must reset the clocks around your home due to a power failure, time charge, or other reason. Remember also to reset the time-of-day on your water conditioner.
- 2** you want recharge to occur at a different time than was set at installation. Note: recharge should be set for a time when water use is at a minimum. (Usually this is in the wee hours of the morning, such as 2:00 a.m.)
- 3** more softening capacity is needed on a continuous basis than was originally set, either because of increased use or change in water characteristics. (If a temporary increase in water use is anticipated or has occurred, an immediate recharge can be initiated without interfering with the automatic settings. Use the "Manual Recharge".)

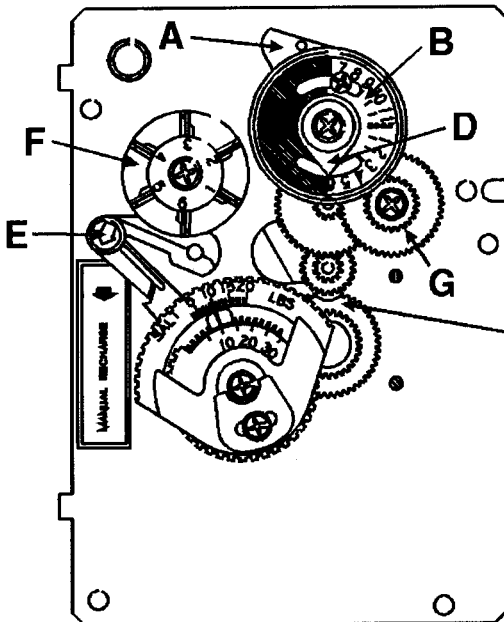

ELECTRO-TIMER™ TIMER MECHANISM

Used on time clock initiated water conditioners.

SERVICE (SOFT WATER) POSITION

The timer is in the "service" position supplying conditioned water to the house lines when the toothless section of the cam gear is over the idler gear.

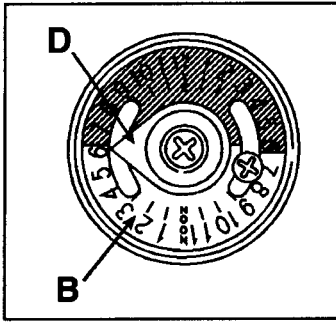

TIME-OF-DAY

The stationary pointer (D) tells the time-of-day on the moving 24-hour dial (B). If the pointer is not pointing to the correct time of day, according to your watch, you can reset this by pulling out on the large gear, behind the time dial, and rotating it until the correct time of day is opposite the pointer. After releasing the gear be certain it meshes properly with the gear (G). Note: the dark half of the time dial represents nighttime hours.

TIME OF RECHARGE

During recharge, hard water is automatically bypassed into the house lines. Recharge time is factory set to start at about 2:00 a.m. when water is not being used by most families. However, if you desire to have your unit charge at a time other than 2:00 a.m., this can be accomplished with a simple adjustment:

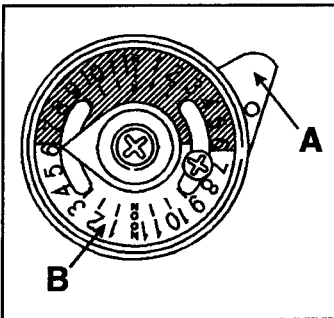

The position of the tiny round peg (A) on the tab indicates the time on the 24-hour dial when the unit will begin to recharge. To change the time of recharge, grasp the outer 24-hour dial (B) and rotate until the desired recharge time on the dial is opposite the peg (A). Note: Whenever the time of recharge is changed, the time of day setting must also be changed following above instructions. (When you reset time of day, double check to be sure that the time of recharge is not accidentally changed in the process.)

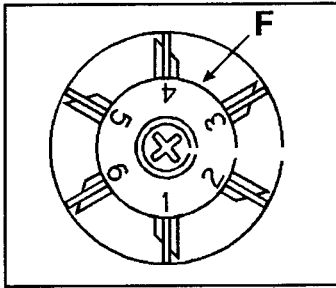

FREQUENCY OF RECHARGE

The frequency of recharge was pre-set for your expected family needs when the water conditioner was installed.

There are six stainless steel tabs on a numbered wheel (F) which program recharge. When all six tabs are pushed in, the unit will recharge every day; if ever other tab is in, recharge will occur every other day; if two opposite tabs are in, recharge will be every third day; and if only one tab is in, recharge occurs every sixth day.

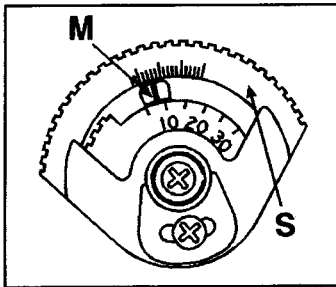

REMEMBER

Push IN to recharge, pull OUT to skip.

SALT ECONOMIZER..

Has a dial (S) which controls the pounds of salt used per recharge. This was set at time of installation. Before making any change, phone your Culligan dealer for advice on the proper setting, then make these adjustments.

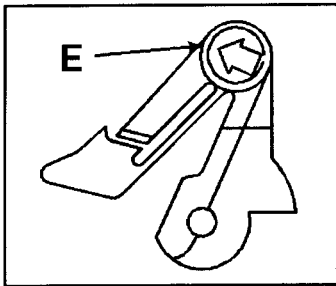

Loosen screw in center of dial (S). While holding cam gear stationary, rotate the dial until desired salt dosage in pounds is aligned with mark (M). Then tighten screw.

If salt dosage is changed, the float on the brine valve in the salt container must also be repositioned. See Installation Manual or call your dealer.

MANUAL RECHARGE FOR MORE SOFTENING CAPACITY

When you expect guests or feel that your use of soft water will temporarily increase, you can get more softening capacity with a manual recharge.

This can be initiated by moving the lever (E) all the way to the left in the direction of the arrow.

After the lever is released, it will return to its original position. Recharge will begin within a few minutes. After manual recharge, the unit will resume its automatic, programmed cycle.

NOTE: Initiating a manual recharge within two (2) hours of a scheduled recharge may cause the timer mechanism to malfunction. For example, if the conditioner is scheduled to recharge at 2:00 a.m., do not initiate a manual recharge after 12:00 Midnight.

SALT SUPPLY, USAGE AND SERVICE

Salt is the mineral used to "recharge" your water conditioner. A brine solution is automatically made up in the bottom of the salt storage container and, as explained on page 7, the Culllex[®] resin beads in the mineral tank are flushed with the brine solution as a step in the recharging process.

Your Culligan[®] Water Conditioner has been carefully designed to get the greatest amount of softening capacity from the salt it uses. Here is some pertinent information about salt usage, types and service.

SALT ECONOMIZER

This control is set at the time of installation, and determines salt usage according to the water hardness, number of persons in the household, and water usage. See page 10 for instructions on adjusting setting.

WHAT KIND OF SALT IS BEST

All Culligan Water Conditioners are designed to use any water conditioner salt of good quality, including "rock", "pellet", "solar", or "evaporated" types.

All rock salt, regardless of source, contains insoluble material which collects at the bottom of the salt storage tank and requires periodic clean-out.

If purified salt products are used, the salt storage compartment will require less frequent clean-out, but you must check more frequently for "bridging" (see p. 15).

Regardless of what type of salt is used, we recommend Culligan Brand Salt as suggested by your Culligan Dealer. He or she is the expert and can provide you with the best product for your Culligan Water Conditioner.

AUTOMATIC SALT DELIVERY SERVICE

Ask your Culligan Man for details about his salt delivery service. You can have your salt supply replenished on a regular basis. Whether you have automatic delivery service, or pick up salt from your Culligan Man, you will be getting quality salt packaged according to rigid Culligan specifications. Using Culligan Brand Salt will help assure continued efficiency and trouble-free operation of your water conditioner.

SODIUM INFORMATION: *"Water softeners using sodium chloride for regeneration add sodium to the water. Persons who are on sodium restricted diets should consider the added sodium as part of their overall sodium intake."*

CARE AND CLEANING OF YOUR CULLIGAN® WATER CONDITIONER

Following these simple precautions will help assure continued trouble-free service, and keep your Culligan Water Conditioner looking like new for years.

- 1** Do not place heavy objects on top of the salt storage tank or timer cover.
- 2** Use only mild soap and warm water when cleaning the exterior of the conditioner. Never use harsh, abrasive cleaning compounds or those which contain acid, such as vinegar, bleach and similar products.
- 3** **Important: Protect your water conditioner and the entire drainline from freezing temperatures. DANGER: If your unit should freeze, do not attempt to disassemble it. Call your Culligan dealer.**
- 4** The timer is reasonably accurate. Keep time-of-day setting correct to assure recharging at the proper time.

Important: Culligan water softeners are sold for use on potable water, only. If at any time the water becomes contaminated, such as during a "boil water" situation, the operation of the water softener should be discontinued until it is verified that the water is again potable. To do this, push the red knob on the back of the water softener against the barrel of the bypass valve. Then, call your Culligan dealer to have your system sanitized before it is placed back into service.
- 5** Should service, adjustment or troubleshooting information be needed which is not covered in the Use and Care Guide, call your Culligan Dealer.
- 6**

NOTE: Following the manufacturer's instructions regarding operation, maintenance and replacement requirements, including replacement of filters if applicable, is essential for Culligan's products to perform as advertised.

If you have further questions, please call your local independently operated Culligan dealer. He or she will be glad to be of assistance to you.

TO CLEAN OUT THE SALT STORAGE TANK

A periodic clean-out of the Salt Storage Tank is necessary to keep your Culligan® Water Conditioner at peak operating efficiency. Do it at least every 2 years when the salt supply is low. Follow these step-by-step procedures:

Tools Needed:

- Scoop
- Clean, bucket-size container
- Phillips-head screwdriver
- Garden hose
- Household scrub brush or sponge

1. Remove the salt storage tank cover and the cap from the brine valve chamber.
2. Lift the brine valve out of the brine valve chamber and set aside in an upright position.
3. If you'd like to save any clean, dry salt remaining in the tank, remove it and place it in a clean container.
4. Using the scoop, dig out and discard as much remaining salt, water and debris as possible.
5. Remove the brine valve chamber by removing the screws on either side of the salt tank.
6. Remove the salt plate at the bottom of the brine tank.
7. Lay the salt tank on its side and direct a brisk stream of water from your garden hose to its inside to rinse out all residue.
8. Using a household scrub brush and a mild soapy solution, clean the salt plate. This will complete the tank cleaning.
9. Stand salt tank upright. Replace the salt plate. Place brine valve chamber in position and affix with screws.
10. Insert the brine valve into the chamber and replace brine valve chamber cap.
11. Fill the salt storage tank with 4 to 6 inches of water.
12. Fill the tank with salt to within a few inches from the top.
13. Replace salt storage tank cover.

THINGS TO CHECK BEFORE YOU CALL FOR SERVICE

If you unexpectedly experience hard water, make these simple checks before calling your Culligan dealer. One of the following conditions may be the reason for your interruption of service.

IMPORTANT

If any of the following conditions is found, the water conditioner should be manually recharged according to instructions on page 10 after you have corrected the problem.

POWER SUPPLY

Check your power supply cord. Is it plugged fully into the electric outlet? Be certain that the outlet is not controlled by a wall switch which has been turned off. Reset conditioner to proper time of day and then plug in.

BLOWN FUSE

Check the house fuse or circuit breaker panel. Replace a blown-out fuse or reset an open circuit breaker.

POWER FAILURE

Any interruption in your power supply or time changes - such as daylight savings - will disrupt your conditioner's recharge schedule by causing the timer to run off-schedule. Reset timer to proper time of day.

BYPASS VALVES

Check to see if they are in the proper position. Cul-Flo-Valv® Bypass, if used, should be in the "Push for Soft Water" position. If hand valves are used, see that inlet and outlet valve are opened and that the bypass valve is closed.

NO WATER

If you aren't getting any water flow at all, make sure your water supply is working. Open a tap ahead of the conditioner (outside tap) to see if you have any water pressure. If you have water pressure, check the bypass valve. If it is in the Service (soft water) position, put it into the bypass and call your Culligan dealer for service.

CONTINUOUS FLOW TO DRAIN

If water runs to drain continuously, check to make sure inlet is not in recharge. If it is recharging, allow unit to finish cycle, then reset time of day. (Unit is in recharge if time of day and time of recharge are within 2 hours of each other).

If the unit is not in recharge, unplug electrical cord, place the bypass valve in bypass position, and contact your Culligan dealer for service.

INCREASED USAGE

Guests, family additions, new water-using appliances, etc., all will result in more water usage and will require more capacity from your conditioner. You can reprogram your recharging schedule by following the directions on pages 8, 9, 10 and 11. Call your Culligan dealer for advice and save a service call.

SALT SUPPLY

Check it. Refill if necessary and wait approximately 4 hours for salt to dissolve before initiating a recharge cycle.

SALT BRIDGING

Salt bridging occurs when a space is formed between the salt and the water underneath, preventing the salt from dissolving to make brine. No brine, no soft conditioned water!

High humidity and/or use of some brands of purified salt products may cause a salt bridge to form.

The best way to check and eliminate a salt bridging problem is to take a broom handle or similar instrument and make a mark 34 inches from the end. Then carefully begin to probe down through the salt with the instrument. Should an obstruction be found before the mark on your instrument reaches the rim of the salt storage tank, a salt bridge is likely to have formed. Continue to probe and break the salt bridge completely. *Caution! Do not force the implement past the mark as damage to the horizontal salt plate may occur.*

WHEN AND HOW TO BYPASS YOUR WATER CONDITIONER

Normally, all water except outside lines passes through the water conditioner. There are times when the water conditioner should be bypassed, using the push-button Cul-Flo-Valv[®] Bypass, or a 3-way bypass valve. You should bypass:

- 1** If lines to outside faucets do not bypass the water conditioner, and you do not want to waste soft water on lawn sprinkling or other outside uses.
- 2** If you are going away on vacation and want to save salt by not having the unit recharge while you're away.

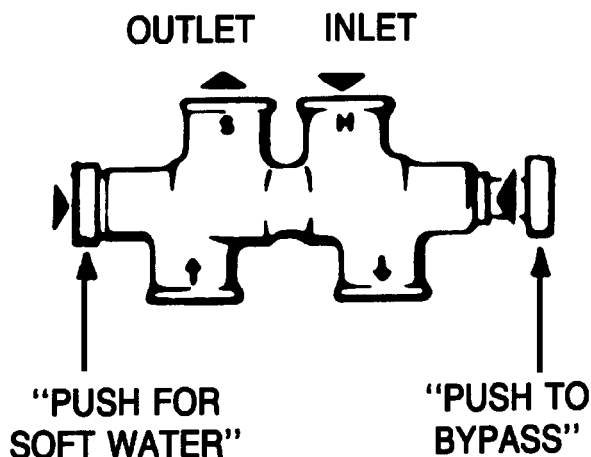

PUSH-BUTTON BYPASS

In the back of most Culligan water conditioners is a push-button Cul-Flo-Valv Bypass. To bypass unit, simply push the red knob (marked "Push to Bypass") all the way to your left. To return to soft water service, reverse the procedure - push the blue knob (marked "Soft Water") all the way to your right.

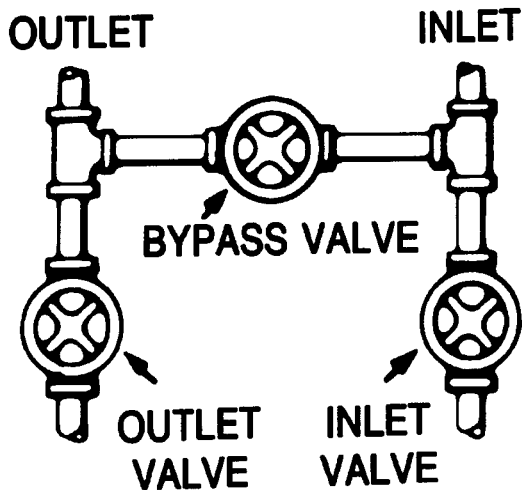

HAND VALVE BYPASS

If the mineral tank is to remain connected while the conditioner is in bypass, close the inlet valve and open the center bypass valve.

WARNING: DO NOT close the outlet valve. This will prevent a possible rupture of the mineral tank or the control valve due to pressure build-up in the mineral tank.

To get soft water, close the center bypass valve and open the inlet valve.

NOTE: If you wish to inspect and clean the control valve, or if a water leak from the conditioner is evident, close both the inlet and outlet valves and open the center bypass valve.

NOTE:

When the conditioner is bypassed, all water used is hard. For example, your water heater may fill with hard water. And the conditioner cannot recharge. Remember to place the push-button Cul-Flo-Valv Bypass or hand valves back to the "Soft Water" position as soon as possible.

RECORDS AND DATA

Important Data on Your Water Conditioner

It is advisable to have the salesperson or installer fill in the information below for your future reference. If this has not been done, please ask for it, as it is necessary if you contact your dealer.

IDENTIFICATION

Model Name _____ Catalog No. _____

Control Model No _____ Control Serial No _____

Date of Installation _____ Tank Serial No _____

SETTINGS

Every Day Every Other Day Salt Setting _____ lbs.

Every 3rd Day Every 6th Day Time of Recharge:

Upon Demand _____ a.m. _____ p.m.

(Aqua-Sensor[®] models)

Number of people in household _____

WATER ANALYSIS

Total Hardness _____ (gpg) Total Iron _____ (ppm) pH (acidity) _____

Other _____

**SHOULD YOU NOTICE ANY NEW PROBLEMS WITH
YOUR WATER, CULLIGAN HAS THE CAPABILITIES
TO SOLVE THEM.**

Today, we have the technology to substantially reduce many of the impurities listed as undesirable by the U.S. EPA in its Drinking Water Standards. Culligan® products and systems reduce both natural and man-made pollutants - provide best water for each specific use and application.

Your new Culligan Water Conditioner can be adjusted to handle a wide range of water problems, but it does have limitations. It has been specified on the basis of your water conditions at the time of sale. It is possible for the chemical makeup of your water to change in time, and such changes cannot be predicted. Your needs and uses may also change. Your independently operated Culligan dealer is ready to help you if any problem should arise.

CULLIGAN LIMITED LIFETIME WARRANTY
CULLIGAN[®] MARK SERIES
AUTOMATIC WATER CONDITIONERS

You have just purchased one of the finest water conditioners made. As an expression of our confidence in Culligan products, your water conditioner is warranted to the original end-user, when installed in accordance with Culligan International Company specifications, against defects in material and workmanship from the date of original installation, as follows:

For a period of ONE YEAR
For a period of FIVE YEARS

The entire conditioner
The control valve timer
The AccuSoft_® circuit board, or Soft-Minder_® meter, if so equipped

For a period of TEN YEARS

The control valve body
The salt storage container, brine valve and all its component parts

For the LIFETIME of the original consumer purchaser

The Tripl-Hull_™ conditioner tank including all internal components and the Culex_® resin

If a part described above becomes defective, within the specified period, you should notify your independently operated Culligan dealer and arrange a time during normal business hours for the dealer to inspect the water conditioner on your premises. Any part found defective within the terms of this warranty will be repaired or replaced by the dealer. You pay only freight from our factory and local dealer charges.

Of course, damage caused by accident, fire, flood, freezing, Act of God, misuse, misapplication, neglect, oxidizing agents, alteration, installation or operation contrary to our printed instructions, or by the use of accessories or components which do not meet Culligan specifications, is not covered by this warranty. Refer to the specifications section in the installation and operating manual for application parameters.

Our product performance specifications are furnished with each water conditioning unit. TO THE EXTENT PERMITTED BY LAW, CULLIGAN DISCLAIMS ALL IMPLIED WARRANTIES INCLUDING, WITHOUT LIMITATION, WARRANTIES OF MERCHANTABILITY AND FITNESS FOR PARTICULAR PURPOSE; TO THE EXTENT REQUIRED BY LAW, ANY SUCH IMPLIED WARRANTIES ARE LIMITED IN DURATION TO THE ONE-YEAR PERIOD SPECIFIED ABOVE FOR THE PARTS DESCRIBED IN THIS LIMITED WARRANTY. As a manufacturer, we do not know the characteristics of your water supply or the purpose for which you are purchasing a water conditioner. Please understand that the quality of water supplies may vary seasonally or over a period of time, and that your water usage rate may vary as well. Water characteristics can also change considerably if your water conditioner is moved to a new location. For these reasons, we assume no liability for the determination of the proper equipment necessary to meet your requirements, and we do not authorize others to assume such obligations for us. Further, we assume no liability and extend no warranties, express or implied, for the use of this product on a non-potable water source. OUR OBLIGATIONS UNDER THIS WARRANTY ARE LIMITED TO THE REPAIR OR REPLACEMENT OF THE FAILED PARTS OF THE WATER CONDITIONER, AND WE ASSUME NO LIABILITY WHATSOEVER FOR DIRECT, INCIDENTAL, CONSEQUENTIAL, SPECIAL, GENERAL, OR OTHER DAMAGES, WHETHER FROM CORROSION OR OTHER CAUSES.

CONSUMERS:

Some states do not allow limitations on how long an implied warranty lasts, so the above limitation may not apply to you. Similarly, some states do not allow the exclusion of incidental or consequential damages, so the above limitation or exclusion may not apply to you. This warranty gives you specific legal rights, and you may also have other rights which vary from state to state. Consult your telephone directory for your local independently-operated Culligan dealer, or write Culligan International Company, for warranty and service information.

CULLIGAN INTERNATIONAL COMPANY
One Culligan Parkway
Northbrook, IL 60062