

# **Water Specialist 1.5", 2" and 2L Control Valve Drawings & Service Manual**

## Table of Contents

WS1.5 Drive Cap Asy, Downflow Piston, Regenerant Piston, Spacer Stack Asy, Main Body and Meter.....	4
WS2L Drive Cap Asy, Downflow Piston, Regenerant Piston, Spacer Stack Asy and Main Body.....	5
WS2 Drive Cap Asy, Downflow Piston, Regenerant Piston, Spacer Stack Asy and Main Body.....	6
Meter Assembly for WS2 and WS2L Valves.....	7
WS1.5 and 2L Injector Cap, Injector Screen, Injector, Plug, Bolts and O-Ring.....	8
WS2 Injector Valve Body, Refill Flow Control and Injector.....	9
WS1.5 and 2L Refill Flow Control Assembly and Refill Port Plug.....	10
WS1.5 and 2L Drain Line 3/4".....	11
WS1.5 and 2L Drain Line 1".....	12
WS1.5 and 2L Drain Line Option.....	13
WS2 Drain Line.....	13
V3053 WS2 2-1/2 Groovelock Clamp Assembly.....	17
Installation Summary.....	18
General Specifications and Pre Installation Check List.....	19
Installation.....	20
Service Instructions.....	23
Troubleshooting Procedures.....	27
Injector Graphs for WS1.5 & WS2L.....	29
Injector Graphs for WS2.....	33

**WS1.5 Drive Cap Assembly, Downflow Piston, Regenerant Piston, Spacer Stack Assembly, Main Body and Meter**

Drawing No.	Order No.	Description	Quantity
1	V3004	WS1 Drive Cap Asy	1
2	V3135	O-ring 228	1
3	V3407	WS1.5 Piston Downflow Asy	1
4	V3174*	WS1 Regenerant Piston	1
5	V3423	WS1.5 Backplate Dowel	1
6	V3430	WS1.5 Spacer Stack Asy	1
7	Back Plate	Refer to Programming and Cover Drawing Manual	1
8	V3419	O-ring 347	1
9	V3418	O-ring 328 for valve bodies with NPT threads	1
	V3441	O-ring 226 for valve bodies with BSPT threads	
Not Shown	V3437	WS1.5 Flow Straightener (located inside meter housing)	1
10	V3401-01	WS1.5 Meter Housing	1
	V3401BSPT-01	WS1.5 Meter Housing BSPT	
11	V3632***	WS1.5/2/3 Meter Retaining Clip	1
12	V3003-02**	WS1.5/2L/2H Meter Commercial Asy	1
13	V3118-03	WS1.5/2L Turbine Asy	1
14	V3105	O-ring 215	1
15	V3501	WS1.5/2 TURBINE CLIP	1
16	V3400-01	WS1.5 Valve Body Downflow	1
	V3400BSPT-01	WS1.5 Valve Body Downflow BSPT	
Not Shown	D1300	TOP BAFFLE DFSR CLACK 1.5/50MM	1

BSPT threads on inlet and outlet ports on the V3400BSPT-01 and V3401BSPT-01. NPT threads on drain and injector ports on V3400BSPT-01.

\*V3174 WS1 Regenerant Piston not used for backwash only valves. V3010-15Z Injector Plug and V3195-01 WS1 Refill Port Plug ASY must be used for backwash only valves.

\*\*Order number V3003-02 includes V3118-03, V3501 and V3105.

\*\*\*In 2008, a modification was made to Meter Housing to use V3632 WS1.5/2/3 Meter Retaining Clip. Do not use V3632 on old style housings which have holes through the casting to accept the U-shaped V3223 WS2 Meter Clip.

If using a meter on WS1.5" valves, select 1.5 if valve software records in gallons and 38 if valve software records in cubic meters.

**Service or replace the turbine by:**

1. Turn the bypass for the system off and relieve the pressure on the system.
2. Press downward on the remote meter assembly to relieve tension on the retaining clip V3632. Remove the clip and take the meter assembly out of the housing.
3. Remove the bend from the two exposed tips of the retaining clip V3501 and remove clip.
4. Service or replace the V3118-03 WS15/2 Turbine Assembly and place it back in the turbine shaft.
5. Insert the V3501 WS15/2 Turbine Clip and re-bend the exposed ends of the clip. The V3118-03 turbine has a groove to line up with the V3501 WS15/2 Turbine Clip.
6. Insert meter assembly back into the meter housing.
7. Re-install the meter retaining clip V3632 as shown below.
8. Open the bypass for the system slowly to bring back into service and check to be sure you have no water leaks.

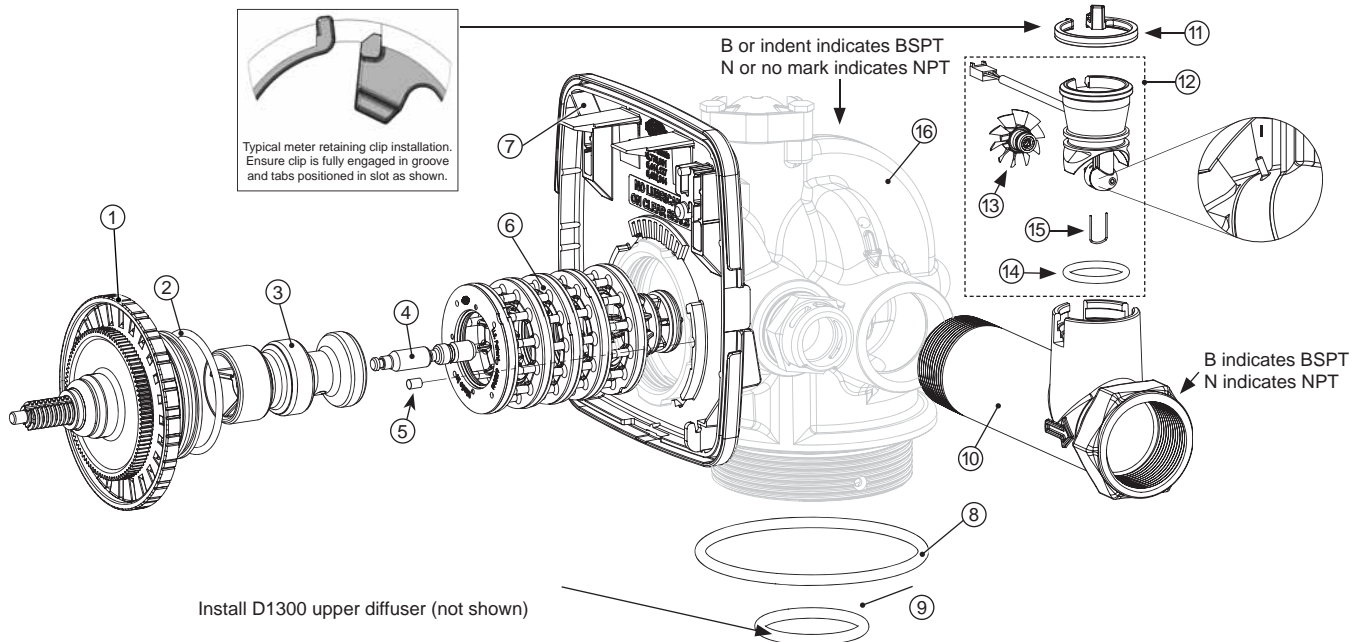

**WS2L Drive Cap Assembly, Downflow Piston, Regenerant Piston, Spacer Stack Assembly and Main Body**

Drawing No.	Order No.	Description	Quantity
1	V3004	WS1 Drive Cap Asy	1
2	V3135	O-ring 228	1
3	V3407	WS1.5 Piston Downflow Asy	1
4	V3174*	WS1 Regenerant Piston	1
5	V3423	WS1.5 Backplate Dowel	1
6	V3430	WS1.5 Spacer Stack Asy	1
7	Back Plate	Refer to Programming and Cover Drawing Manual	1
8	V3419	O-ring 347	1
9	V3418	O-ring 328 for valve bodies with NPT threads	1
	V3441	O-ring 226 for valve bodies with BSPT threads	
Not Shown	H1023-03	TubePoly 3/8 x 1/4 Blk 500 Ft. Roll	.0006
Not Shown	JG-PP481222W	Elbow Fix 3/8 x 1/4 NPTF Polypro	2
10	V3453-03	WS2L Body 4-8 NPT w/V3468 Plug	1
	V3453BSPT-03	WS2L Body 4-8 BSPT w/V3465 Plug	
Not Shown	V3468	WS2 Plug 1/4 Hex NPT (included when ordering V3453-03)	2
	V3465	WS2 Plug 1/4 Hex BSPT (included when ordering V3453 BSPT-03)	
Not Shown	D1300	TOP BAFFLE DFSR CLACK 1.5/50MM	1

BSPT threads on inlet and outlet ports on the V3453BSPT-03. NPT threads on drain and injector ports on V3435BSPT-03.

\*V3174 WS1 Regenerant Piston not used for backwash only valves. V3010-15Z Injector Plug and V3195-01 WS1 Refill Port Plug ASY must be used for backwash only valves.

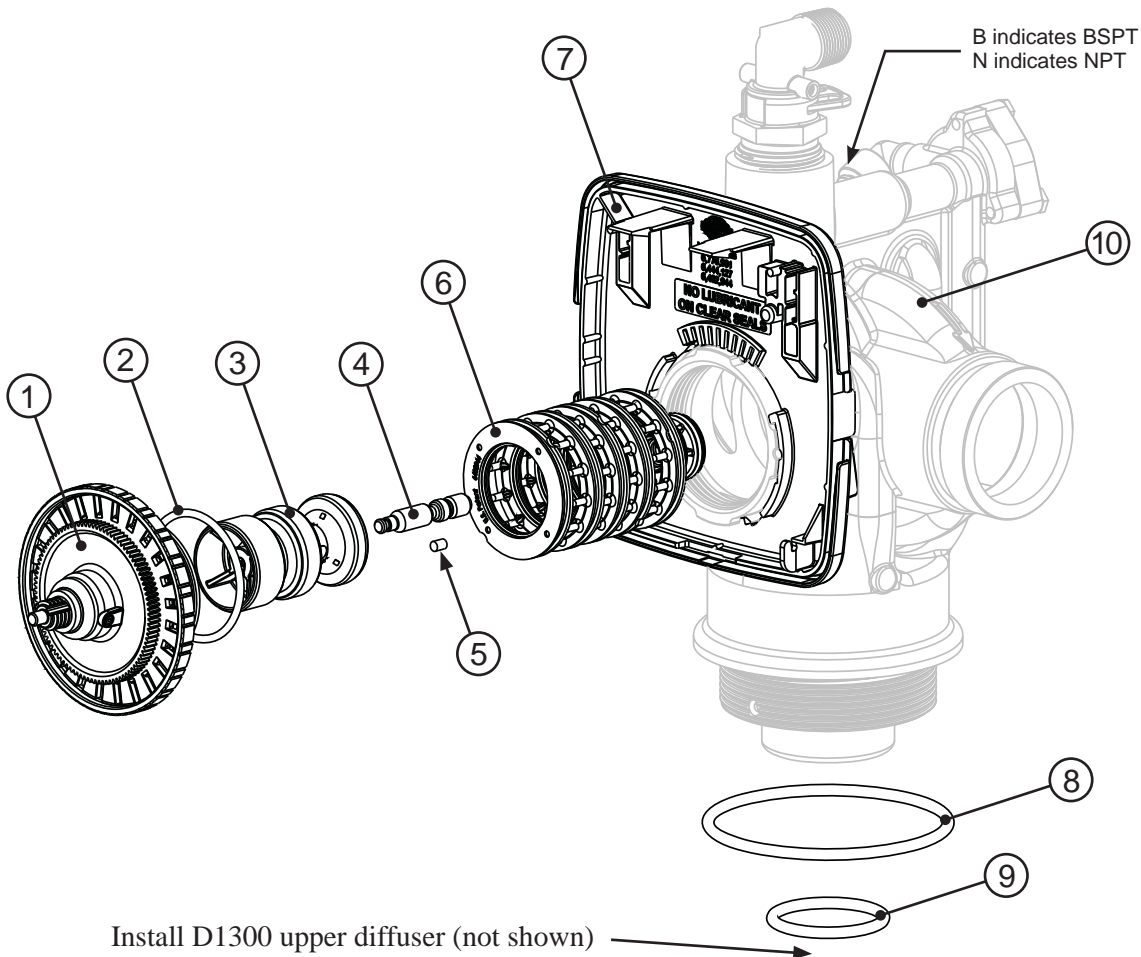

**WS2 Drive Cap Assembly, Downflow Piston, Regenerant Piston, Spacer Stack Assembly and Main Body**

Drawing No.	Order No.	Description	Quantity
1	V3726	WS2 BRINE PISTON ASY	1
2	V3725	WS2 PISTON DOWNFLOW ASY	1
3	V3452	O-RING 230	1
4	V3728	WS2 DRIVE CAP ASY	1
5	V3724	WASHER FLAT SS 1/4	4
6	V3642	BOLT BHCS S/S 1/4-20X1.25	4
7	Back Plate	Refer to Programming and Cover Drawing Manual	1
8	V3729	WS2 STACK ASY	1
9	V3419	O-RING 347 FOR WS15	
10	V3641	O-RING 225 for valve bodies with NPT threads	1
	V3441	O-RING 226 for valve bodies with BSPT threads	
11	V3700-01	WS2 BODY NPT	1
	V3700BSPT-01	WS2 BODY BSPT	
Not Shown	V3468	WS2H PLUG 1/4 HEX NPT	1
	V3465	WS2H PLUG 1/4 HEX BSPT	
Not Shown	D1300	TOP BAFFLE DFSR CLACK 1.5/50MM	1

BSPT threads on inlet and outlet ports on the V3700BSPT-01. NPT threads on the drain port on V3700BSPT-01.

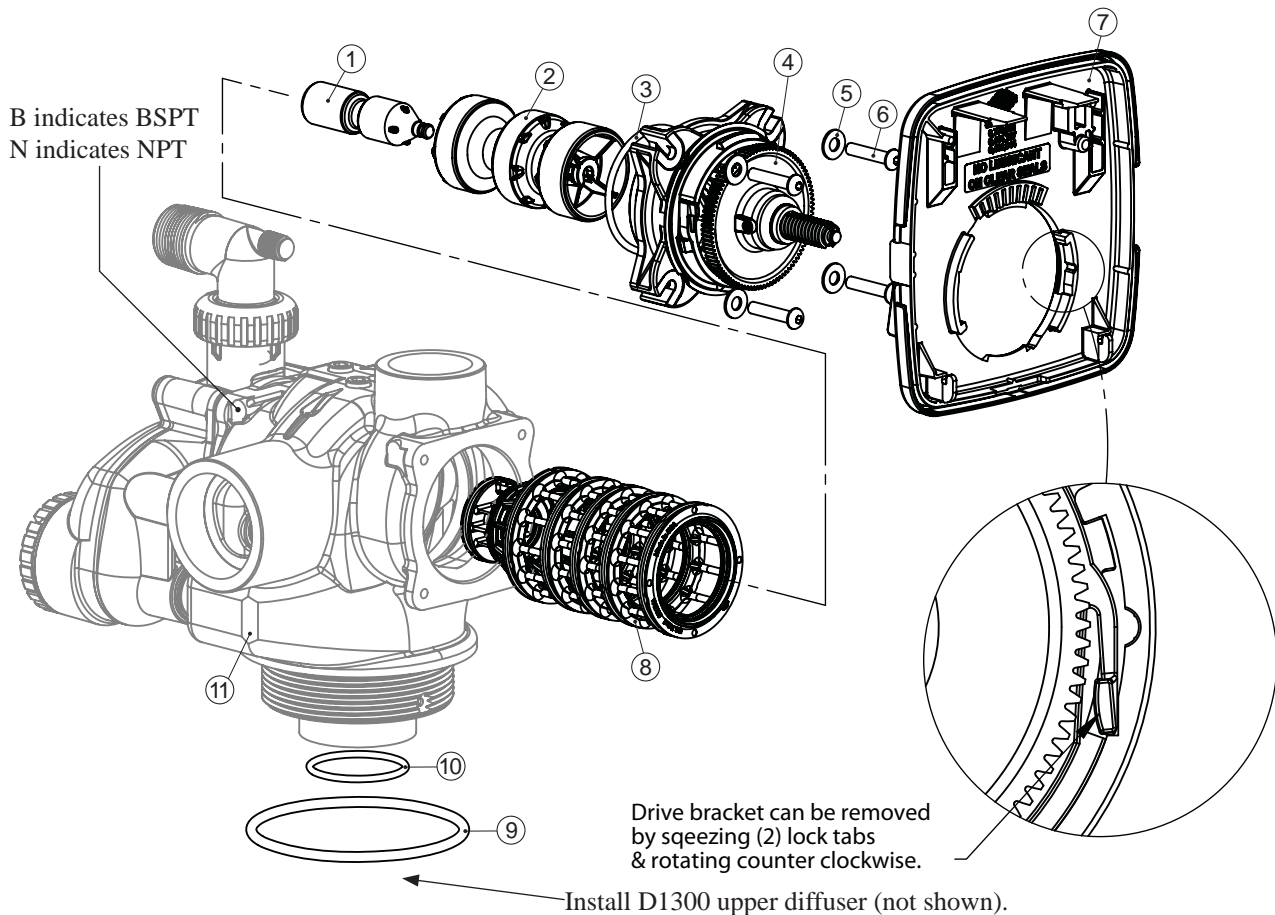

**Meter Assembly for WS2 and WS2L Valves**

Note: Only 2" meters should be used on WS2 valves.

Standard meter cable used for spacing up to 3" between valve body and meter body, longer distance requires longer cable #V3221.

Service or replace the turbine by:

1. Turn the bypass for the system off and relieve the pressure on the system.
2. Press downward on the remote meter assembly to relieve tension on the retaining clip V3632 (or the U-shaped V3223 WS2 Meter Clip). Remove the clip and take the meter assembly out of the housing.
3. Remove the bend from the two exposed tips of the retaining clip V3501 and remove clip.
4. Service or replace the V3118-03 WS1.5/2 Turbine Assembly and place it back in the turbine shaft.
5. Insert the V3501 WS1.5/2 Turbine Clip and re-bend the exposed ends of the clip. The V3118-03 turbine has a groove to line up with the V3501 WS1.5/2 Turbine Clip.
6. Insert meter assembly back into the meter housing.
7. Re-install the meter retaining clip V3632 as shown below (or the U-shaped V3223 WS2 Meter Clip).
8. Open the bypass for the system slowly to bring back into service and check to be sure you have no water leaks.

The V3118-03 has a groove to line up with the V3501 WS1.5/2 Turbine Clip.

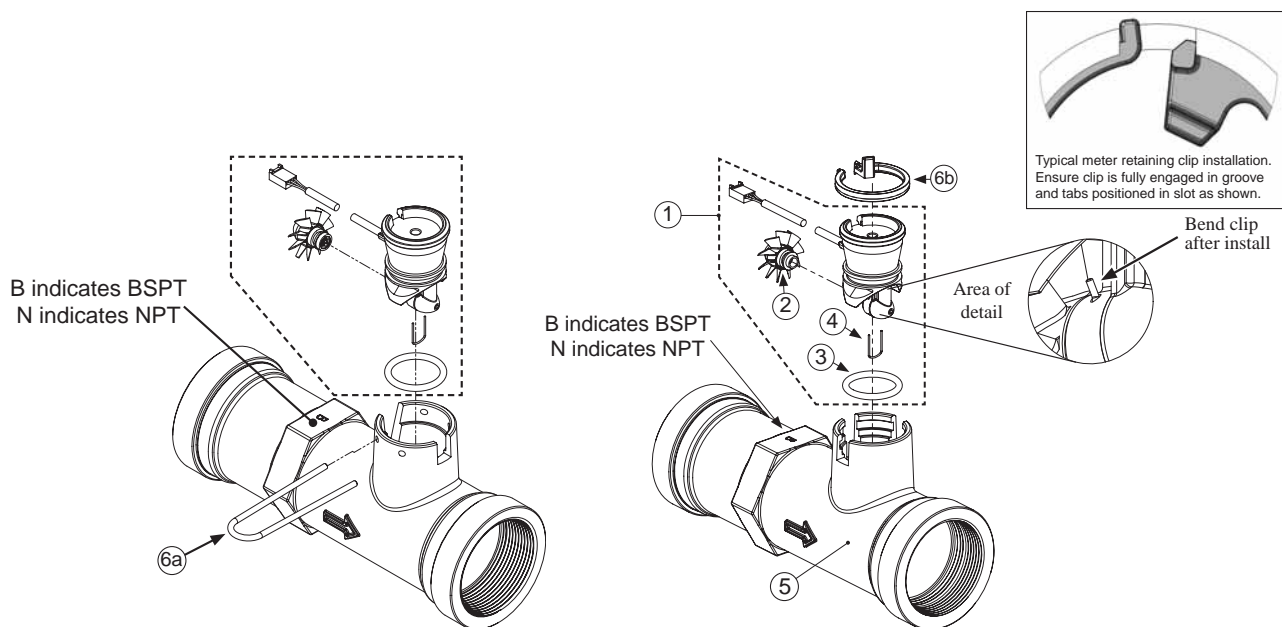

Drawing No.	Order No.	Description	Quantity
1	V3003-02*	WS1.5/2L/2H Meter Commercial Asy	1
2	V3118-03	WS1.5/2 Turbine Asy	1
3	V3105	O-Ring 215	1
4	V3501	WS1.5/2 Turbine Clip	1
5	V3222-01	WS2 Meter NPT Housing	1
	V3222BSPT-01	WS2 Meter BSPT Housing	
6a	V3223	WS2 Meter Clip	1
6b	V3632**	WS1.5/2/3 Meter Retaining Clip	1
Not Shown	V3488	WS2 Flow Straightener (located inside meter housing)	1

Installation of the WS2 Meter NPT Assembly can be accomplished with 2" NPT pipe or by using a 2½" groove lock coupling. For WS2 Meter BSPT Assembly use 63mm pipe. When installing the WS2 Meter Assembly it is necessary that the meter be installed in a horizontal position. After installing the meter, break out the tab in the back plate and thread the meter cord through.

**WHEN INSTALLING THE METER, MAKE SURE THE ARROW ON THE METER BODY IS GOING THE SAME DIRECTION AS THE WATER FLOW.**

**OPERATING PRESSURES: 20 PSI MINIMUM / 125 PSI MAXIMUM • OPERATING TEMPERATURES: 40°F MINIMUM / 110°F MAXIMUM**

\*Order number V3003-02 includes V3118-03, V3501 and V3105.

\*\* In 2008 a modification was made to Meter Housings to use V3632 WS1.5/2/3 Meter Retaining Clip. Do not use V3632 on old style housings which have holes through the castings to accept the U-shaped V3223 WS2 Meter Clip.

**WS1.5 and 2L Injector Cap, Injector Screen, Injector, Plug, Bolts and O-Ring(s)**

Drawing No.	Order No.	Description	Quantity
1	V3422	Bolt	3
2	V3403	WS1.5 Injector Cap	1
3	V3417	O-ring 220	1
4	V3010-15B	WS1.5 Injector Asy B Violet	1
	V3010-15C	WS1.5 Injector Asy C Red	
	V3010-15D	WS1.5 Injector Asy D White	
	V3010-15E	WS1.5 Injector Asy E Blue	
	V3010-15F	WS1.5 Injector Asy F Yellow	
	V3010-15G	WS1.5 Injector Asy G Green	
	V3010-15H	WS1.5 Injector Asy H Orange	
	V3010-15Z	WS1.5 Injector Plug	
5	V3404	WS1.5 Injector Screen	1
Not Shown	V3171	O-ring 013	*
Not Shown	V3416	O-ring 012	*

\*The injector or the injector plug each contain one V3416 o-ring 012 (lower) and one V3171 o-ring 013 (upper).

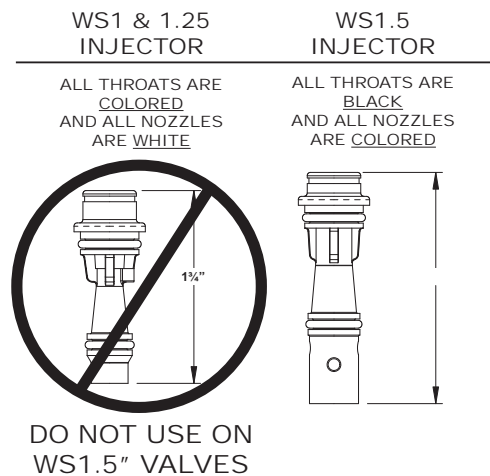
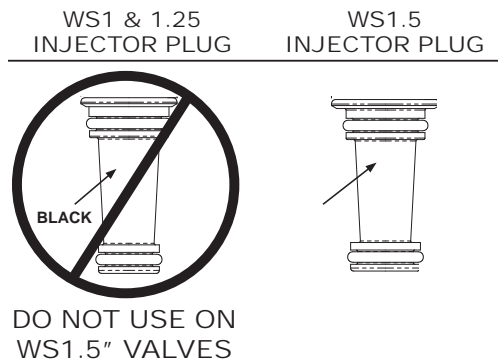
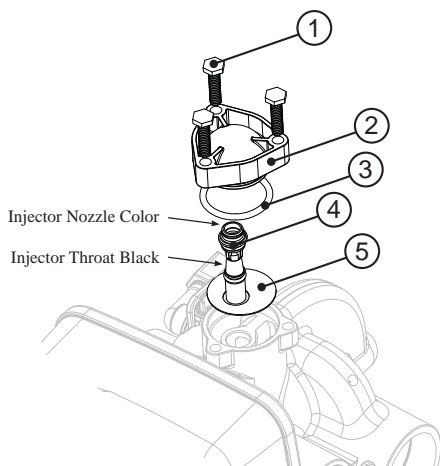
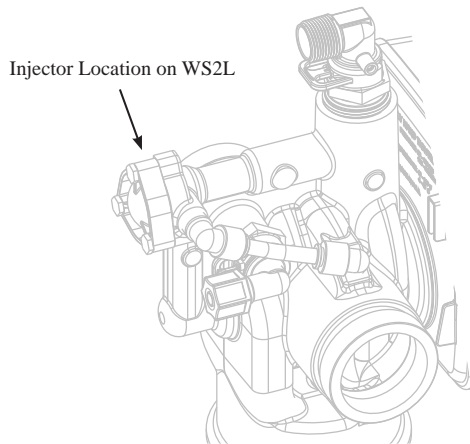

**WS2 Injector Valve Body, Refill Flow Control and Injector**

Drawing No.	Order No.	Description	Quantity
1	V3477	WS2H INJECTOR CAP	1
2	V3152	O-RING 135	1
3	V3727	WS2 INJECTOR BODY ASY	1
4	V3010-2R-15B	WS2/2H INJECTOR R ASY W/V3010-15B	1
	V3010-2S-15C	WS2/2H INJECTOR S ASY W/V3010-15C	
	V3010-2T-15D	WS2/2H INJECTOR T ASY W/V3010-15D	
	V3010-2U-15E	WS2/2H INJECTOR U ASY W/V3010-15E	
	V3010-2V-15F	WS2/2H INJECTOR V ASY W/V3010-15F	
	V3010-2W-15G	WS2/2H INJECTOR W ASY W/V3010-15G	
	V3010-2X-15H	WS2/2H INJECTOR X ASY W/V3010-15H	
	V3010-2A	WS2/2H INJECTOR ASY A	
	V3010-2B	WS2/2H INJECTOR ASY B	
	V3010-2C	WS2/2H INJECTOR ASY C	
	V3010-2D	WS2/2H INJECTOR ASY D	
	V3010-2E	WS2/2H INJECTOR ASY E	
	V3010-2F	WS2/2H INJECTOR ASY F	
V3010-2G	WS2/2H INJECTOR ASY G		
5	V3731	WS2 INJ DRAW TUBE DOWN ASY	1
6	V3730	WS2 INJ FEED TUBE DOWN ASY	1
7	V3315	O-RING 231	1
8	V3724	WASHER FLAT SS 1/4	4
9	V3643	BOLT BHCS S/S 1/4-20x2.25	4
10	V3162-022*	WS1 DLFC 022 FOR 3/4	1
11	V3231	WS2H REFILL FLOWCNTRL RETAINER	1
12	V3277	O-RING 211	1
13	V3105	O-RING 215	1
14	V3150	WS1 SPLIT RING	1
15	V3151	WS1 NUT 1 QC	1
16	V3149	WS1 FTG 1 PVC MALE NPT ELBOW	1
Not Shown	V3189	WS1 FTG 3/4&1 PVC SLVNT 90	Optional
Not Shown	H4915**	FTG KIT 494 BV 1/2 POLYTUBE	Optional
Not Shown	V3499	WS2H FITTING CAP 1 IN THREADED	Optional

\*Any V3162-XXX flow control may be used. WS2 valves are shipped with a V3162-022 (2.2 gpm) flow control. Flow control sizes range from 0.7 up to 10 gpm. WS2 valves can only be set for minutes of fill because various sizes of flow controls can be used. To calculate for pounds or kilograms of salt, take minutes of fill times the flow rate of the flow control being used to arrive at the number of gallons of water be added to the brine tank. Each gallon of water will dissolve approximately 3 pounds of salt.

\*\*Use of H4915 may severely reduce brine draw rates.

A V3731 WS2 INJ DRAW TUBE DOWN ASY contains one D1262 O-RING 118 and two V3639 O-RING 119.

A V3730 WS2 INJ FEED TUBE DOWN ASY contains three V3638 O-RING 113.

V3010-2X injectors and the V3010-15ADAPTER contain a V3283 O-RING 117 and a V3284 O-RING 114. The V3010-15ADAPTER can be used with any V3010-15X injector so the 2" valve can be used on smaller tank sizes. The V3010-15X injector contains one V3416 O-RING 012 (lower) and one V3171 O-RING 013 (upper).

Backwash Only Valves include a V3499 but do not include the following parts: V3189, H4915, V3162-022, V3231 and V3277.

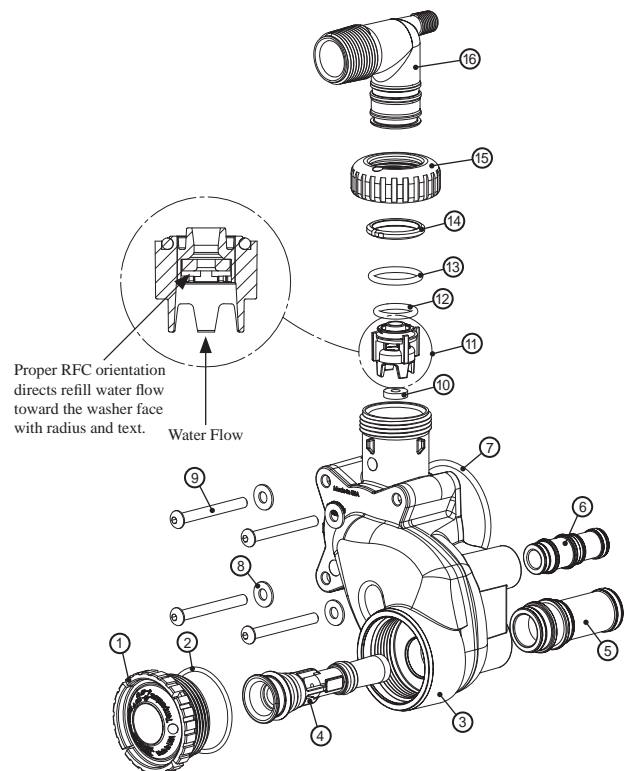



**WS1.5 and 2L Refill Flow Control Assembly and Refill Port Plug**

Drawing No.	Order No.	Description	Quantity
1	V3195-01	WS1 Refill Port Plug Asy	1
2	V3415	WS1.5 BLFC Adapter	1
3	H4615	Clip Retaining	1
4	V3428*	WS1.5 Refill Retainer ASY	1
5	V3163	O-ring 019	1
6	H4612	Elbow Cap 1/2"	1
7	JCPG-8PBLK	Nut Compression 1/2" Black	1
8	JCP-P-8	Insert Polytube 1/2"	1
9	V3182	WS1 RFC	1
10	V3498	WS1.5 Brine Elbow Asy w/RFC 1/2"	Option
Not Shown	V3434-01	WS1.5 Refill Asy 5/8 x 3/4 (includes fitting, refill retainer assembly, o-ring, nut and polytube insert for 5/8" brine line connection)	Option

\*V3428 contains a V3182 WS1 RFC

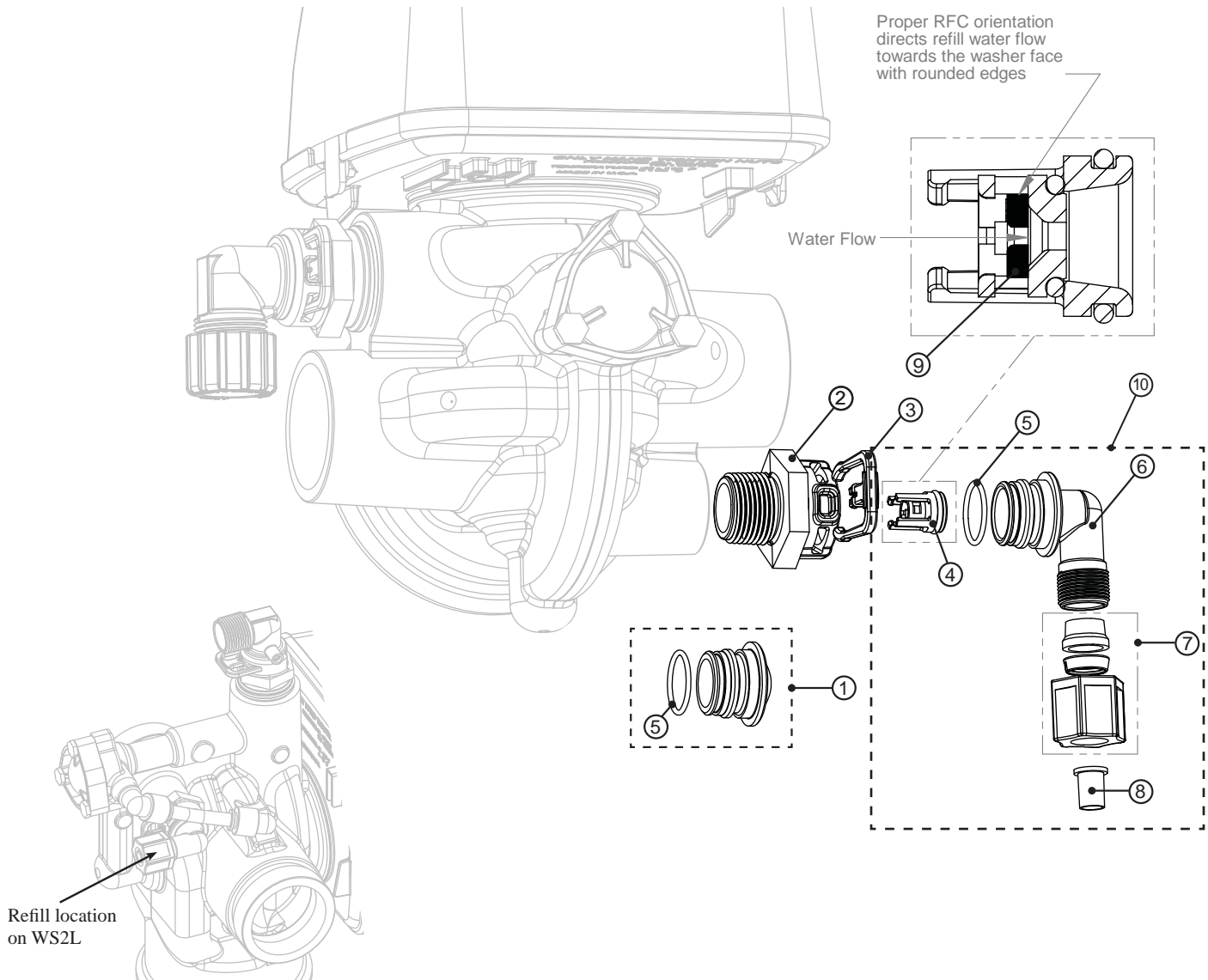

WS1.5 and 2L Drain Line 3/4"

Drawing No.	Order No.	Description	Quantity
1	H4615	Locking Clip	1
2	V3414	WS1.5 DLFC Adapter	1
3*	V3158-01	WS1 Drain Elbow 3/4" Male Asy	1
4	V3163	O-ring 019	1
5*	V3159-01	WS1 DLFC Retainer Asy	1
6	V3162-032	WS1 DLFC 3.2 gpm (12.1 lpm) for 3/4"	One DLFC must be used if 3/4" fitting is used
	V3162-042	WS1 DLFC 4.2 gpm (15.9 lpm) for 3/4"	
	V3162-053	WS1 DLFC 5.3 gpm (20.1 lpm) for 3/4"	
	V3162-065	WS1 DLFC 6.5 gpm (24.6 lpm) for 3/4"	
	V3162-075	WS1 DLFC 7.5 gpm (28.4 lpm) for 3/4"	
	V3162-090	WS1 DLFC 9.0 gpm (34.1 lpm) for 3/4"	
	V3162-100	WS1 DLFC 10.0 gpm (37.9 lpm) for 3/4"	

\* 3 & 5 can be ordered as a complete assembly - V3331 WS1 Drain Elbow and Retainer Asy  
 Valves are shipped without drain line flow control (DLFC) – install DLFC before using. Use a minimum drain line size of 3/4".

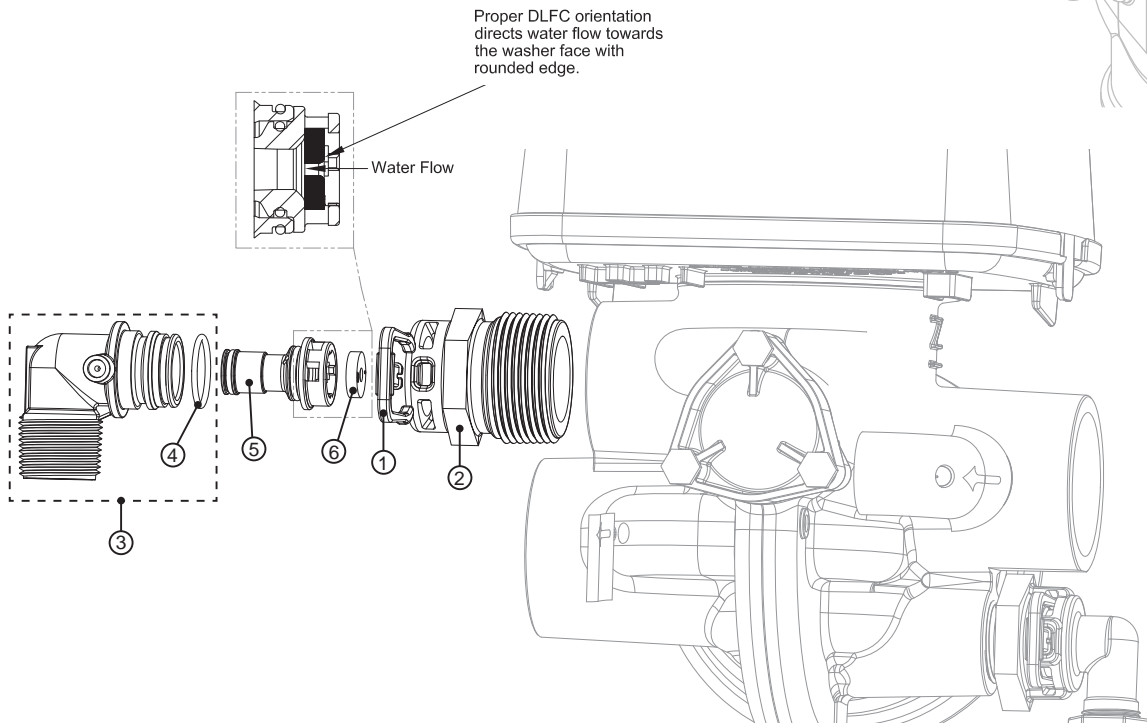
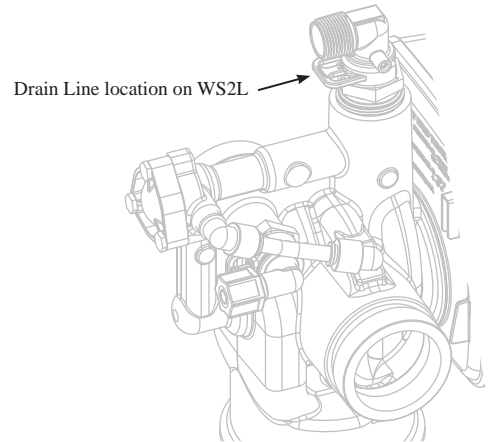

WS1.5 and 2L Drain Line 1"

Drawing No.	Order No.	Description	Quantity
1	H4615	Locking Clip	1
2	V3414	WS1.5 DLFC Adapter	1
3	V3008-02	WS1 Drain Ftg 1" Straight	1
4*	V3163	O-ring 019	1
5*	V3167	WS1 Drain Ftg Adapter 1"	1
6*	V3151	WS1 Nut 1" QC	1
7*	V3150	WS1 Split Ring	1
8*	V3105	O-ring 215	1
9*	V3166	WS1 Drain Ftg Body 1"	1
10	V3190-090	WS1 DLFC 9.0 gpm (34.1 lpm) for 1"	One DLFC must be used if 1" fitting is used
	V3190-100	WS1 DLFC 10.0 gpm (37.9 lpm) for 1"	
	V3190-110	WS1 DLFC 11.0 gpm (41.6 lpm) for 1"	
	V3190-130	WS1 DLFC 13.0 gpm (49.2 lpm) for 1"	
	V3190-150	WS1 DLFC 15.0 gpm (56.8 lpm) for 1"	
	V3190-170	WS1 DLFC 17.0 gpm (64.4 lpm) for 1"	
	V3190-200	WS1 DLFC 20.0 gpm (75.7 lpm) for 1"	
	V3190-250	WS1 DLFC 25.0 gpm (94.6 lpm) for 1"	

\* Can be ordered as a set, order number V3008-02 WS1 Drain Ftg 1" Straight

Drain Line location on WS2L

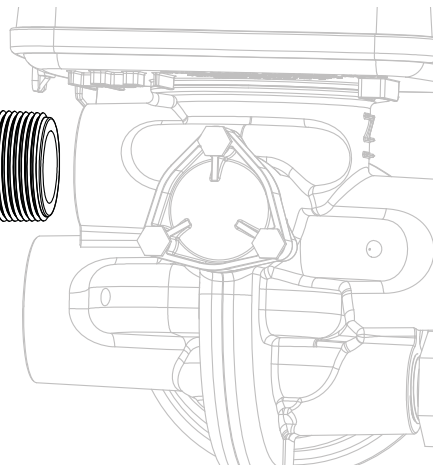
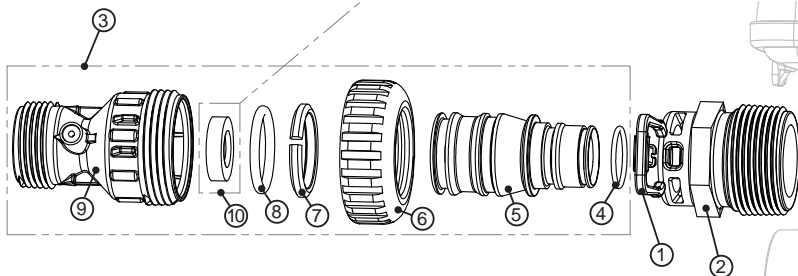
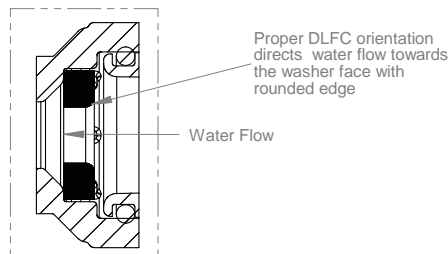
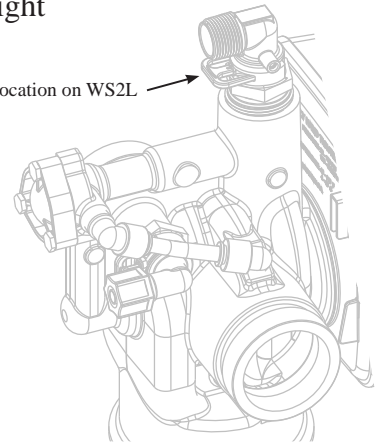

### WS1.5 and 2L Drain Line Option

The drain port on the WS1.5 & 2L is 1.25" Female NPT threads. V3079 WS DLFC ASY 125 FNPT/15 FNPT and V3079BSPT WS DLFC ASY 125 FNPT/15 FBSPT are options available for purchase to control the rate of flow to drain. Requires one V3190-XXX drain line flow control washer and up to six of the V3162-XXX drain line flow control washers. Flow rate ranges from 9 gpm up to 85 gpm. Requires separate purchase of a length (dependant on back plate dimensions) of male NPT to male NPT threaded pipe or fitting and put Teflon tape on both ends. Remove the existing fitting from the valve body.

### WS2 Drain Line

The drain port on the WS2 is 1.5" Female NPT threads. The following options are available for purchase to control the rate of flow to drain:

- V3158-04 WS2 DRN ELBOW 3/4 90 W/O SIL. Accepts one V3162-XXX drain line flow control washer with flow rate range up to 10 gpm. Adapter and reducing bushing included in assembly.
- V3008-05 WS2 FTG DRAIN 1 STRT W/O SIL. Accepts one V3190-XXX drain line flow control washer with flow rate range from 9 gpm up to 25 gpm. Adapter and reducing bushing included in assembly.
- V3080 WS DLFC ASY 15 MNPT/15 FNPT or V3080BSPT WS DLFC ASY 15 MNPT/15 FBSPT. Requires one V3190-XXX drain line flow control washer and up to six of the V3162-XXX drain line flow control washers. Flow rate ranges from 9 gpm up to 85 gpm.

**V3079 WS DLFC ASY 125 FNPT/15 FNPT, V3079BSPT WS DLFC ASY 125 FNPT/15 FBSPT, V3080 WS2 DLFC Assembly 15 MNPT/15 FNPT or V3080BSPT WS DLFC Assembly 15 MNPT/15 FBSPT**

Drawing No.	Order No.	Description	Quantity			
			V3079	V3079BSPT	V3080	V3080BSPT
1	V3081	WS15 RETAINER DLFC ASY	1	1	1	1
2	V3645	WS15 DLFC FLANGE OUTLET FNPT	1		1	
	V3645BSPT	WS15 DLFC FLANGE OUTLET FBSPT		1		1
3	V3646	WS15 DLFC FLANGE INLET MNPT			1	1
4	V3647	WS125 DLFC FLANGE INLET FNPT	1	1		
5	V3652	BOLT HEXHD S/S HCS 5/16-18x3/4	4	4	4	4
6	V3441	O-RING 226	1	1	1	1
Not Shown	V3162-007	WS1 DLFC 0.7 gpm for 3/4	Install at least one V3190-XXX in center hole. Knock out plugs allow installation of up to 6 more of V3162-XXX.			
	V3162-010	WS1 DLFC 1.0 gpm for 3/4				
	V3162-013	WS1 DLFC 1.3 gpm for 3/4				
	V3162-017	WS1 DLFC 1.7 gpm for 3/4				
	V3162-022	WS1 DLFC 2.2 gpm for 3/4				
	V3162-027	WS1 DLFC 2.7 gpm for 3/4				
	V3162-032	WS1 DLFC 3.2 gpm for 3/4				
	V3162-042	WS1 DLFC 4.2 gpm for 3/4				
	V3162-053	WS1 DLFC 5.3 gpm for 3/4				
	V3162-065	WS1 DLFC 6.5 gpm for 3/4				
	V3162-075	WS1 DLFC 7.5 gpm for 3/4				
	V3162-090	WS1 DLFC 9.0 gpm for 3/4				
	V3162-100	WS1 DLFC 10.0 gpm for 3/4				
	V3190-090	WS1 DLFC 09.0 gpm for 1				
	V3190-100	WS1 DLFC 10.0 gpm for 1				
	V3190-110	WS1 DLFC 11.0 gpm for 1				
	V3190-130	WS1 DLFC 13.0 gpm for 1				
	V3190-150	WS1 DLFC 15.0 gpm for 1				
V3190-170	WS1 DLFC 17.0 gpm for 1					
V3190-200	WS1 DLFC 20.0 gpm for 1					
V3190-250	WS1 DLFC 25.0 gpm for 1					

Assemblies are shipped without drain line flow control (DLFC). Assembly instructions:

- Determine the desired flow rate. Select one V3190-XXX for the center hole and a combination of V3162-XXX to arrive at the desired flow rate. At least one V3190-XXX must be used and up to six of the V3162-XXX may be used.
- Using a drill or punch remove the desired knockout(s) in V3081.
- Smooth holes.
- Install appropriate size(s) of drain line flow control washers. Pay close attention to proper DLFC orientation.
- Fit V3441 o-ring onto V3081 Retainer DLFC Asy and assemble. Properly orientate the V3081 in direction of flow.
- Inlet threads for 1.25" female are NPT. Inlet threads for 1.5" male are NPT. Outlet threads for 1.5" are either female NPT or BSPT. 1.5" female outlet is stamped with N or B to indicate NPT or BSPT.

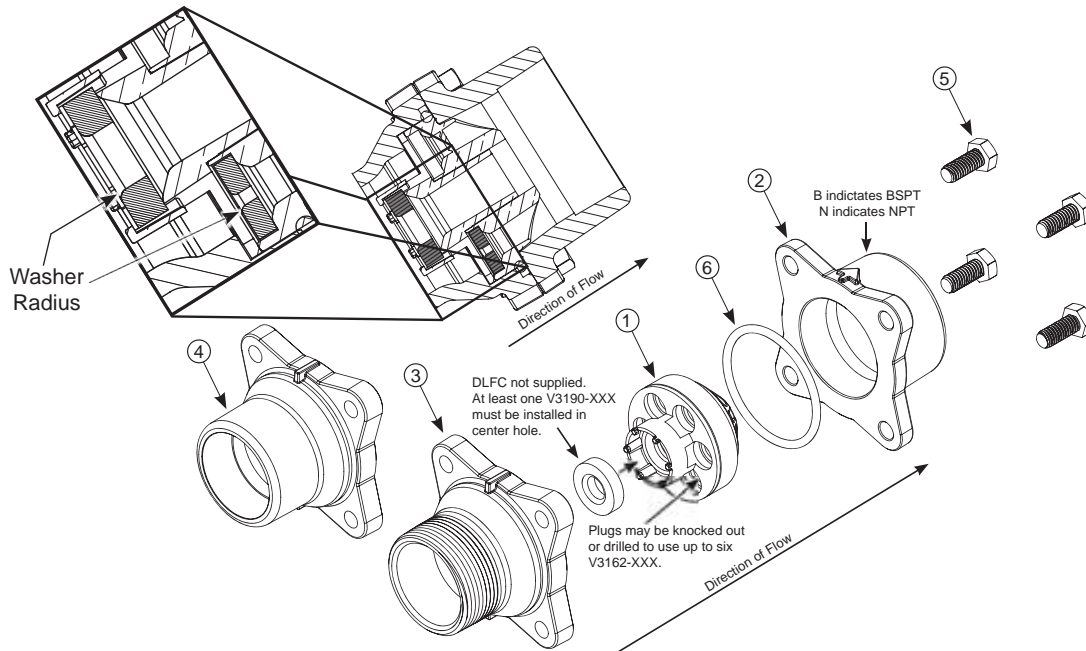

V3158-04 WS2 Drain Elbow 3/4" Male NPT Without Silencer

Drawing Number	Order Number	Description	Qty
1	V3649	BUSHING PVC SCH80 1.5/1.25 NPT	1
2	V3414	WS15 DLFC ADAPTER	1
3	H4615	CLIP RETAINING 474/WS1	1
4	V3162-007	WS1 DLFC 0.7 gpm for 3/4	ONE DLFC MUST BE USED IF 3/4" FITTING IS USED.
	V3162-010	WS1 DLFC 1.0 gpm for 3/4	
	V3162-013	WS1 DLFC 1.3 gpm for 3/4	
	V3162-017	WS1 DLFC 1.7 gpm for 3/4	
	V3162-022	WS1 DLFC 2.2 gpm for 3/4	
	V3162-027	WS1 DLFC 2.7 gpm for 3/4	
	V3162-032	WS1 DLFC 3.2 gpm for 3/4	
	V3162-042	WS1 DLFC 4.2 gpm for 3/4	
	V3162-053	WS1 DLFC 5.3 gpm for 3/4	
	V3162-065	WS1 DLFC 6.5 gpm for 3/4	
	V3162-075	WS1 DLFC 7.5 gpm for 3/4	
	V3162-090	WS1 DLFC 9.0 gpm for 3/4	
V3162-100	WS1 DLFC 10 gpm for 3/4		
5	V3159-01	WS1 DLFC RETAINER ASY	1
6	V3163	O-RING 019	1
7	V3158-03	WS1 DRN ELBOW 3/4 MALE NO HOLE	1

This assembly is shipped without drain line flow control (DLFC) – install DLFC before using. Use a minimum drain line size of 3/4".

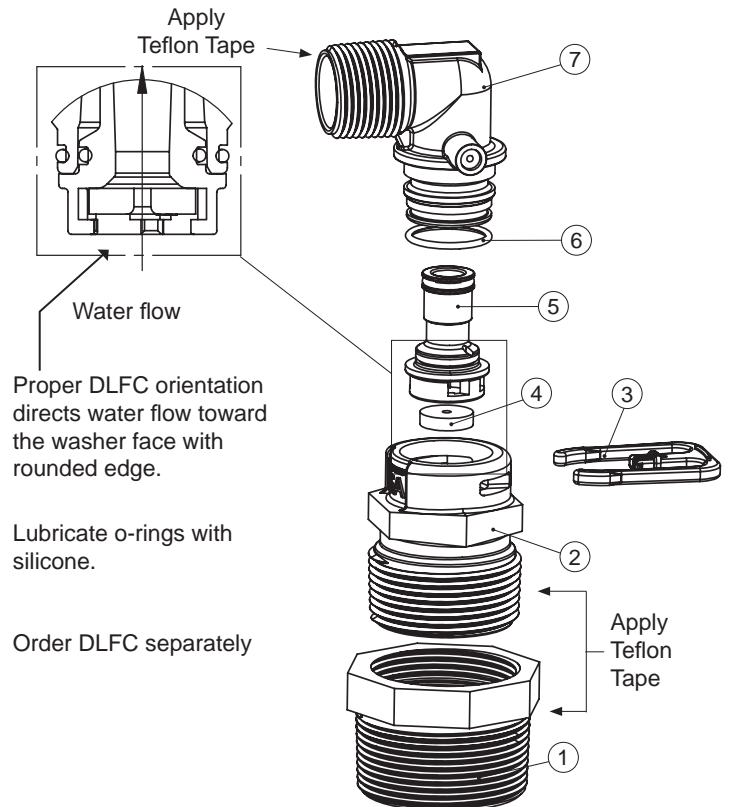

**V3008-05 WS2 Fitting Drain 1" Male NPT Straight Without Silencer**

Drawing Number	Order Number	Description	Qty
1	V3166-01	WS1 FTG FLOW CONTROL BODY	1
2	V3167	WS1 DRAIN FTG ADAPTER 1	1
3	V3163	O-RING 019	1
4	V3150	WS1 SPLIT RING	1
5	V3151	WS1 NUT 1" QC	1
6	V3105	O-RING 215	1
7*	V3190-090	WS1 DLFC 9.0 GPM FOR 1	ONE DLFC MUST BE USED IF 1" FITTING IS USED.
	V3190-100	WS1 DLFC 10.0 GPM FOR 1	
	V3190-110	WS1 DLFC 11.0 GPM FOR 1	
	V3190-130	WS1 DLFC 13.0 GPM FOR 1	
	V3190-150	WS1 DLFC 15.0 GPM FOR 1	
	V3190-170	WS1 DLFC 17.0 GPM FOR 1	
	V3190-200	WS1 DLFC 20.0 GPM FOR 1	
	V3190-250	WS1 DLFC 25.0 GPM FOR 1	
8	H4615	CLIP RETAINING	1
9	V3414	WS1.5 DLFC ADAPTER	1
10	V3649	BUSHING PVC SCH 80 1.5 TO 1.25 NPT	1

\* Order DLFC separately.

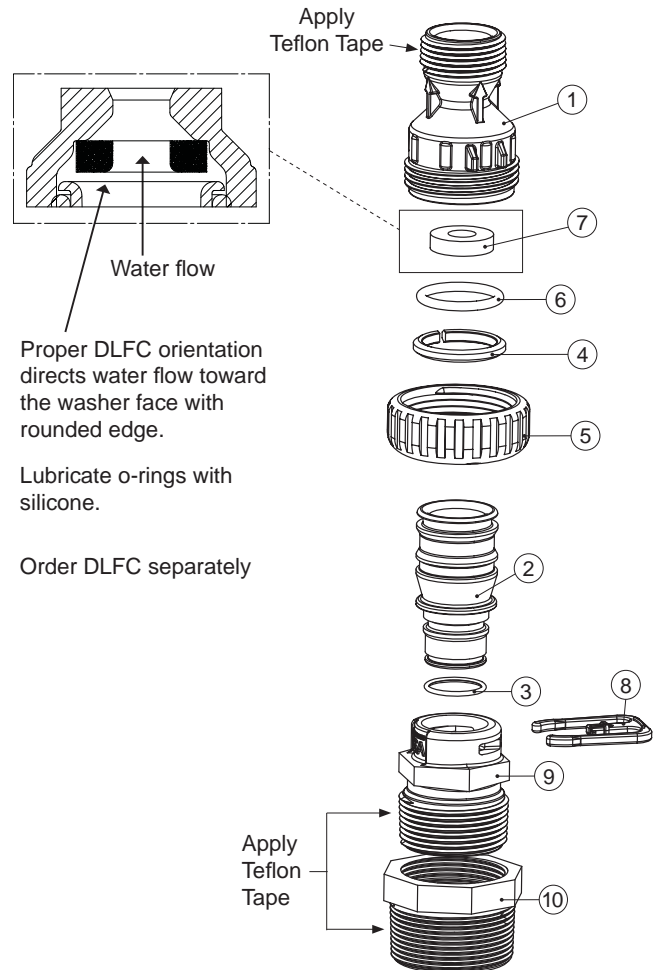

V3053 WS2 2-1/2 GROOVELOCK CLAMP ASY

Drawing No.	Order No.	Description	Quantity
1	V3053	WS2 2-1/2 GROOVELOCK CLAMP ASY	1
2	V3290	WS2 GROOVE LOCK SEAL 2.5	1
3	V3269	WS2 NUT 5/16-18 SS HEX	1
4	V3293	WS2 WASHER SS 5/16 FLAT	1
5	V3276	WS2 BOLT HEX SS 5/16-18X1-3/4	1
Not Shown	S3086	SILICONE LUBRICANT	1

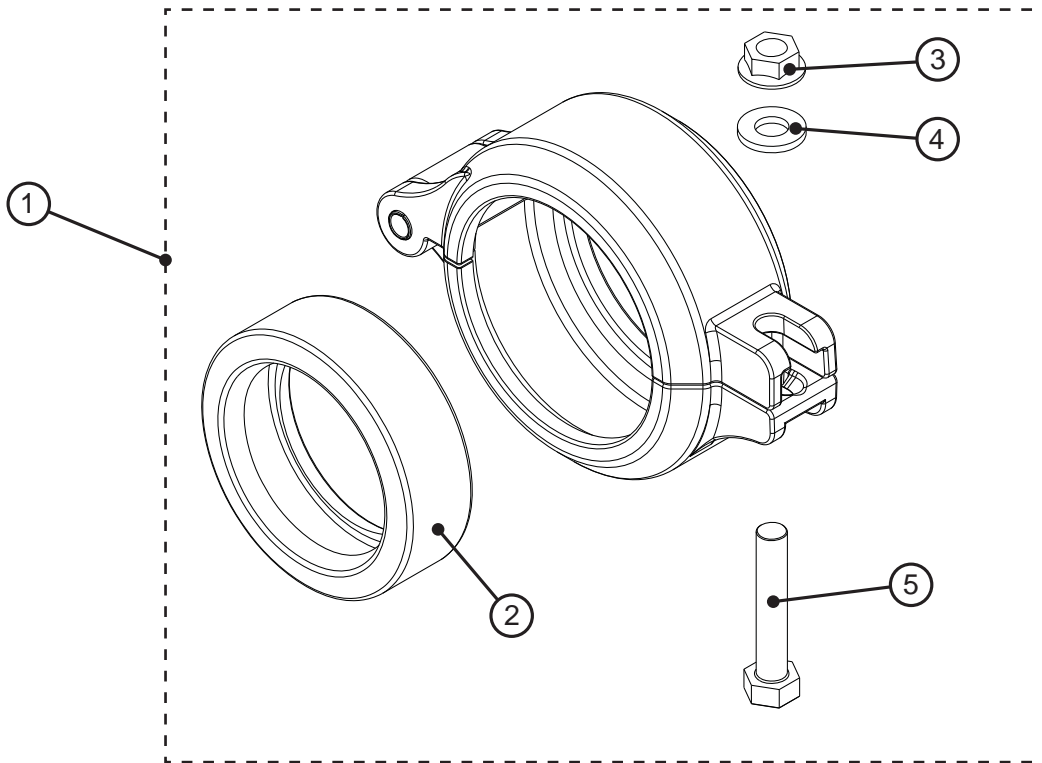



---

---

## Installation Summary

Installation Date: \_\_\_\_\_

Installation Location: \_\_\_\_\_

Installer(s): \_\_\_\_\_

Phone Number: \_\_\_\_\_

Application Type: (Softener) \_\_\_\_\_ Other: \_\_\_\_\_

**Water Source:** \_\_\_\_\_

### Water Test Results:

Hardness: \_\_\_\_\_ Iron: \_\_\_\_\_ pH: \_\_\_\_\_

Other: \_\_\_\_\_

---

### Misc:

Service Flow Rates: min. \_\_\_\_\_ max. \_\_\_\_\_

Tank Size: Diameter \_\_\_\_\_ Height: \_\_\_\_\_

Resin or Media Volume: \_\_\_\_\_

Resin or Media Type: \_\_\_\_\_

Capacity: \_\_\_\_\_

Salt or Fill Setting per Regeneration: \_\_\_\_\_

Brine Tank Size: \_\_\_\_\_

### Control Valve Configuration:

Valve Type: \_\_\_\_\_

Valve Part Number: \_\_\_\_\_

Valve Serial Number: \_\_\_\_\_

Regenerant Refill Control: \_\_\_\_\_ gpm/lpm

Injector Size: \_\_\_\_\_

Drain Line Flow Control: \_\_\_\_\_ gpm/lpm

**Table 1**  
**General Specifications and Pre-Installation Checklist**

Minimum/Maximum Operating Pressures	20 psi (138 kPa) -125 psi (862 kPa)
Minimum/Maximum Operating Temperatures	40°F (4°C) - 110°F (43°C)
Power Adapter: Supply Voltage Supply Frequency Output Voltage Output Current	See Front Cover and Drive Assembly drawing
No user serviceable parts are on the PC board, the motor, or the Power adapter. The means of disconnection from the main power supply is by unplugging the Power adapter from the wall.	
Service flow rate	1.5" Valve: 60 gpm (227 lpm) @ 15 psig (103 kPa) drop 2L Valve: 75 gpm (284 lpm) @ 15 psig (103 kPa) drop 2" Valve: 115 gpm (435 lpm) @ 15 psig (103kPa) drop
Backwash flow rate	1.5" & 2L Valve: 50 gpm (189 lpm) @ 25 psig (172 kPa) drop 2" Valve: 80 gpm (303 lpm) @ 25 psig (172kPa) drop
CV Service	1.5" Valve: 15.5 2L Valve: 19.4 2" Valve: 29.7
CV Backwash	1.5: & 2L Valves: 10.0 2" Valve: 16.0
Meter: Accuracy Flow Range	± 5% 1.5" Valve: 0.5 – 60 gpm (1.9 – 227 lpm) 2" & 2L Valves: 1.5 – 150 gpm (5.7 – 568 lpm)
Regenerant Refill Rate	1.5: & 2L Valves: 0.5 gpm (1.9 lpm) 2" Valve: Variable
Injectors	1.5: & 2L Valves: See Injector Graphs V3010-15A through 15H 2" Valve: See Injector Graphs V3010-2A through 2G
Inlet / Outlet	1.5" Valve: 1.5" Female NPT or BSPT 2" & 2L Valves: 2" Female NPT or BSPT
Drain Line	1.5: & 2L Valves: 1.25" Female NPT 2" Valve: 1.5" Female NPT
Distributor Tube Opening Valve bodies with female NPT Inlet & Outlet Valve bodies with female BSPT Inlet & Outlet	1.90" OD (1.5" NPS) 50 mm OD
Tank Connection	4" – 8 UN
Shipping Weight	1.5" Valve and Meter: 21 lbs (10 kg) 2L Valve and Meter: 29 lbs (13 kg) 2" Valve and Meter: 30 lbs (14 kg)
PC Board Memory	Nonvolatile EEPROM (electrically erasable programmable read only memory)
Compatible with the following typical concentrations of regenerants/chemicals	Sodium chloride, potassium chloride, potassium permanganate, sodium bisulfite, chlorine and chloramines

## Installation

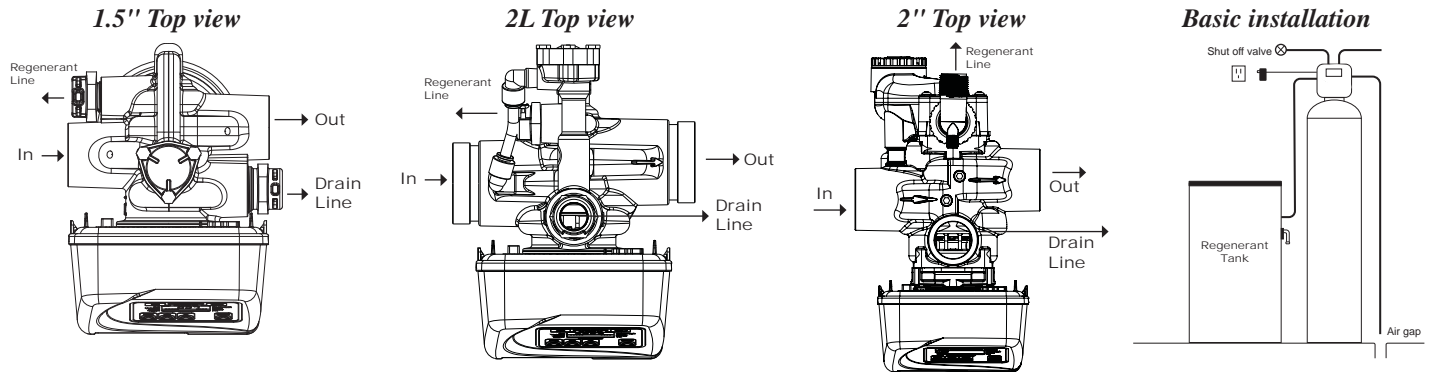

### GENERAL INSTALLATION & SERVICE WARNINGS

The control valve and fittings are not designed to support the weight of the system or the plumbing.

Do not use Vaseline, oils, other hydrocarbon lubricants or spray silicone anywhere. A silicone lubricant may be used on black o-rings but is not necessary. Avoid any type of lubricants, including silicone, on clear lip seals.

**THIS WATER METER SHOULD NOT BE USED AS THE PRIMARY MONITORING DEVICE FOR CRITICAL HEALTH EFFECT APPLICATIONS**

Do not use pipe dope or other sealants on threads. Teflon tape is recommended to be used on all threads. Use of pipe dope may break down the plastics in the control valve.

### SITE REQUIREMENTS:

- The plug-in Power adapter is for dry locations only
- The tanks should be on a firm, level surface
- Electrical: Use an uninterrupted outlet installed within 15 feet (4.57 meters) of the water conditioner.

All plumbing should be done in accordance with local codes.

1. Locate the water conditioner so the distance between the drain and the water conditioner is as short as possible.
2. Regenerant tanks that must be refilled should be located where they are easily accessible. It is recommended a safety brine valve be used.
3. Do not install any water conditioner with less than 10 feet of piping between its outlet and the inlet of a water heater.
4. Do not locate unit where it or its connections (including the drain and overflow lines) will ever be subjected to room temperatures under 40° F (4° C).
5. The use of resin cleaners in an unvented enclosure is not recommended.
6. **INLET/OUTLET PLUMBING:** Connect to a supply line downstream of outdoor spigots. Install an inlet shutoff valve and plumb to the unit's inlet located at the left front as you face the unit. Installation of a bypass valve is recommended. If using plastic fittings ground the water conditioner per local electric codes. If a water meter is used, install the water meter parallel to the floor on the outlet side of the control valve. The turbine assembly may be orientated in any direction, but is usually orientated pointing up to reduce drainage out of the pipes during service. Remove the cover and drive bracket and thread the water meter cord through the hole in the back plate. Reinstall the drive bracket. Weave the cord through the hooks on the right hand side of the drive bracket and connect the end to the three prong connector labeled **METER** on the printed circuit board. Replace the cover.
7. **Drain:** Verify that the drain can handle the backwash rate of the water conditioner. Correctly size the drain line and install an appropriately sized drain line flow control. For 1.5 & 2L valves an adapter fitting is supplied with a valve that can connect to a 3/4" fitting that can be used with drain line flow controls up to 10 gpm, or an optional 1" fitting that can be used with drain line flow controls up to 25 gpm. If necessary the adapter can be removed and the 1 1/4" NPT threaded drain outlet may be used. For 2" valves the drain outlet is 1.5" NPT threads. Solder joints near the drain must be done prior to connecting the drain line flow control fitting. Leave at least 6" (152.4 mm) between the drain line flow control fitting and solder joints to prevent heat from damaging the flow control. Avoid elevating the drain line above the control valve where possible. Discharge the drain line through an air gap to a receptacle in accordance with local plumbing codes.

**IMPORTANT: Never insert a drain line directly into a drain, sewer line, or trap. Always allow an air gap between the drain line and the receptacle to prevent back siphonage.**

8. Regeneration: If the control valve is to be used to regenerate the water conditioner with brine (saturated salt solution) or other regenerants, use a polyethylene tube to connect the brine valve contained in the regenerant tank to the regenerant port on the control valve. It is recommended the brine valve contain a safety float. The 1.5 & 2L control valve regenerant port has a 1/2" fitting. Note that 1/2" tube runs longer than 6 feet may restrict draw rates with G and H injectors. A 5/8" fitting is also available. See the Refill Flow Control Assembly diagram in the Programming and Drawings Manual for injector part numbers. See Table 2a for injector color codings.

**Table 2a**  
**1.5 & 2L Valve Injector Order Information**

Injector Order Number	Injector Color	Typical Tank Diameter <sup>1</sup>
V3010-15B	Violet	12"
V3010-15C	Red	13"
V3010-15D	White	14"
V3010-15E	Blue	16"
V3010-15F	Yellow	18"
V3010-15G	Green	21"
V3010-15H	Orange	24"

The 2" control valve regenerant port has a 1" threaded outlet connection. To ensure acceptable operation of the injectors use 1" pipe to connect to the brine tank. Smaller drain line flow controls may result in the injector performance not matching the injector graphs. Use an adequately size drain line flow control to ensure proper brine draw.

**Table 2b**  
**2" Valve Injector Order Information**

Injector Order Number	Typical Tank Diameter <sup>1</sup>
V3010-2R-15B	12"
V3010-2S-15C	13"
V3010-2T-15D	14"
V3010-2U-15E	16"
V3010-2A	18"
V3010-2V-15F	18"
V3010-2B	21"
V3010-2W-15G	21"
V3010-2C	24"
V3010-2X-15H	24"
V3010-2D	30"
V3010-2E	36"
V3010-2F	42"
V3010-2G	48"

All injector graphs are at the end of this manual for total, slow rinse and draw flow rates.

An overflow drain line from the regenerant tank that discharges into an acceptable drain is recommended, as a regenerant overflow could damage furnishings or the building structure. Connect a line to the overflow fitting on the regenerant tank. If an overflow fitting is not already installed on the regenerant tank, install one. Do not elevate the overflow drain line. Discharge the overflow drain line through an air gap to a receptacle in accordance with local plumbing codes.

9. Power Adapter: If a Power Adapter is already connected to the control valve, plug the Power Adapter into an uninterrupted outlet. If the Power Adapter cord has not yet been connected to the control valve, remove the control valve cover and the drive bracket and thread Power Adapter cord through the hole in the back plate. Reinstall the drive bracket. Weave the cord through the hooks on the right hand side of the drive bracket and connect the end to the four prong connector on the printed circuit board. Replace the cover. Plug the Power Adapter into an uninterrupted outlet.

10. Program the control valve: It is very important to program the control valve for the type of system (e.g. water softener or filter) and the end use application. Check the program used prior to testing the system.

<sup>1</sup> Actual injector size used may vary depending on the design and application of the system. The injectors in Tables 2a & 2b are sized for a typical downflow softener using standard mesh synthetic cation exchange media regenerating with sodium chloride.

### Systems with a Regenerant Tank

- After installation is completed, check for leaks.
- Fully open a cold water faucet down stream of the system.
- Allow water to run until clear.
- Close the cold water faucet and water supply valve.
- The system is now ready for testing:
  1. Manually pour enough water into the regenerant tank to reach the top of the air check valve.
  2. Press and hold the REGEN button for three seconds until the drive motor starts. Wait until the motor stops and the display reads "Backwash." The backwash time will begin to count down.
  3. Open the inlet water supply valve very slowly allowing water to fill the tank in order to expel air. CAUTION: If water flows too rapidly, there will be a loss of media out of the drain.
  4. When the water is flowing steadily to the drain without the presence of air, press the REGEN button to advance the control to the brine position. The brine time will begin to count down.
  5. Fully open the water supply inlet valve.
    - Check to verify that water is being drawn from the regenerant tank
    - There should be a slow flow to the drain
    - Allow three minutes for the media bed to settle
  6. Press the REGEN button again to advance to the next position and allow water to run to drain for 2-3 minutes. The display will read "backwash" or "rinse" depending on the program used. If "backwash" is displayed, press the REGEN button to advance the control to the rinse position. Allow water to run to drain until clear.
  7. Press the REGEN button to advance to the next position. The display should read "fill". Allow water to run into the regenerant tank and prepare it for the next regeneration. Allow the regenerant tank to fill automatically.
  8. While the regenerant tank is filling, load it with regenerant.
  9. SANITIZE! Add a sanitizer to the regenerant tank brine well following dosage recommendations specified by the media manufacturer. Press and hold the REGEN button for three seconds to begin regeneration. Allow the system to complete the regeneration automatically. The system will now be sanitized and producing treated water. Be sure to check for local codes, which may also specify sanitization methods.

### Systems without a Regenerant Tank

- After installation is completed, check for leaks.
- Fully open a cold water faucet down stream of the system.
- Allow water to run until clear.
- Close the cold water faucet and water supply valve.
- The system is now ready for testing:
  1. Press and hold the REGEN button for three seconds until the drive motor starts. Wait until the motor stops and the display reads "Backwash." The backwash time will begin to count down.
  2. Open the inlet water supply valve very slowly allowing water to fill the tank in order to expel air. CAUTION: If water flows too rapidly, there will be a loss of media out of the drain.
  3. When the water is flowing steadily to the drain without the presence of air, fully open the water supply inlet valve.
  4. Press the REGEN button again to advance to the next position and allow water to run to drain for 2-3 minutes. The display will read "backwash" or "rinse" depending on the program used. If "backwash" is displayed, press the REGEN button to advance to the rinse position. Allow water to run to drain until clear.
  5. Press the REGEN button to advance to the service position.
  6. SANITIZE! Add a sanitizer to the media following dosage recommendations specified by the media manufacturer. Be sure to check for local codes, which may also specify sanitization methods.

## Service Instructions

### Drive Assembly

Remove the valve cover to access the drive assembly.

Disconnect the power source plug (black wire) from the PC board prior to disconnecting the motor or water meter plugs from the PC board. The motor plug connects to the two-pin jack on the left-hand side of the PC board. The power source plug connects to the four-pin jack. The water meter plug (gray wire) connects to the three-pin jack on the far right-hand side of the PC board.

The PC board can be removed separately from the drive bracket but it is not recommended. Do not attempt to remove the display panel from the PC board. Handle the board by the edges. To remove the PC board from the drive bracket, unplug the power, water meter and motor plugs from the PC board. Lift the middle latch along the top of the drive bracket while pulling outward on the top of the PC board. The drive bracket has two plastic pins that fit into the holes on the lower edge of the PC board. Once the PC board is tilted about 45° from the drive bracket it can be lifted off of these pins. To reinstall the PC board, position the lower edge of the PC board so that the holes in the PC board line up with the plastic pins. Push the top of the PC board towards the valve until it snaps under the middle latch, weave the power and water meter wires into the holders and reconnect the motor, water meter and power plugs.

The drive bracket must be removed to access the drive cap assembly and pistons or the drive gear cover. It is not necessary to remove the PC board from the drive bracket to remove the drive bracket. To remove the drive bracket start by removing the plugs for the power source and the water meter. Unweave the wires from the side holders. Two tabs on the top of the drive back plate hold the drive bracket in place. Simultaneously lift the two tabs and gently ease the top of the drive bracket towards your body. The lower edge of the drive bracket has two notches that rest on the drive back plate. Lift up and outward on the drive bracket to disengage the notches.

To reassemble seat the bottom of the drive bracket so the notches are engaged at the bottom of the drive back plate. Push the top of the drive bracket towards the two latches. The drive bracket may have to be lifted slightly to let the threaded piston rod pass through the hole in the drive bracket. Maintain a slight engaging force on top of the drive bracket while deflecting the bracket slightly to the left by pressing on the side of the upper right corner. This helps the drive gears mesh with the drive cap assembly. The drive bracket is properly seated when it snaps under the latches on the drive back plate. If resistance is felt before latching, then notches are not fully engaged, the piston rod is not in hole, the wires are jammed between the drive bracket and drive back plate, or the gear is not engaging the drive cap assembly.

To inspect drive gears, the drive gear cover needs to be removed. Before trying to remove the gear cover, the drive bracket must be removed from the drive back plate. (Refer to the instructions above regarding removing the drive bracket from the drive back plate. The drive gear cover can be removed from the drive bracket without removing the motor or the PC board.) The drive gear cover is held in place on the drive bracket by three clips. The largest of the three clips is always orientated to the bottom of the drive bracket. With the PC board facing up, push in and down on the large clip on the drive gear cover. Handle the cover and the gears carefully so that the gears do not fall off of the pegs in the cover.

Replace broken or damaged drive gears. Do not lubricate any of the gears. Avoid getting any foreign matter on the reflective coating because dirt or oils may interfere with pulse counting.

The drive gear cover only fits on one way, with the large clip orientated towards the bottom. If all three clips are outside of the gear shroud on the drive bracket the drive gear cover slips easily into place.

The drive bracket does not need to be removed from the drive plate if the motor needs to be removed. To remove the motor, disconnect the power and motor plugs from the jacks on the PC board. Move the spring clip loop to the right and hold. Rotate the motor at least a ¼ turn in either direction before gently pulling on the wire connectors to remove the motor. Pulling directly on the wires without rotating the motor may break the wires off the motor.

Replace the motor if necessary. Do not lubricate the motor or the gears. To reinstall the motor, move the spring clip loop to the right and hold. Gently turn the motor while inserting so that the gear on the motor meshes with the gears under the drive gear cover. Release the spring clip loop and continue to rotate the motor until the motor housing engages the small plastic bulge inside the drive bracket motor retainer. Reconnect the motor plug to the two-pronged jack on the lower left hand side of the PC board. If the motor will not easily engage with the drive gear when reinstalling, lift and slightly rotate the motor before reinserting. Reconnect the power plug.

Replace the valve cover. After completing any valve maintenance, press and hold NEXT and REGEN buttons for 3 seconds or unplug power source jack (black wire) and plug back in. This resets the electronics and establishes the service piston position. The display should flash all wording, then flash the software version and then reset the valve to the service position.

#### Drive Cap Assembly, Main Piston and Regenerant Piston

The drive assembly must be removed to access the drive cap assembly. The drive cap assembly must be removed to access the piston(s). The drive cap assembly is threaded into the control valve body and seals with an o-ring. To remove the drive cap assembly use the special plastic wrench (V3193-02 Figure 1) or insert a ¼" to ½" flat bladed screwdriver into one of the slots around the top 2" of the drive cap assembly so it engages the notches molded into the drive back plate around the top 2" of the piston cavity. See Figure 2. The notches are visible through the holes. Lever the screwdriver so the drive cap assembly turns counter clockwise. Once loosened unscrew the drive cap assembly by hand and pull straight out.

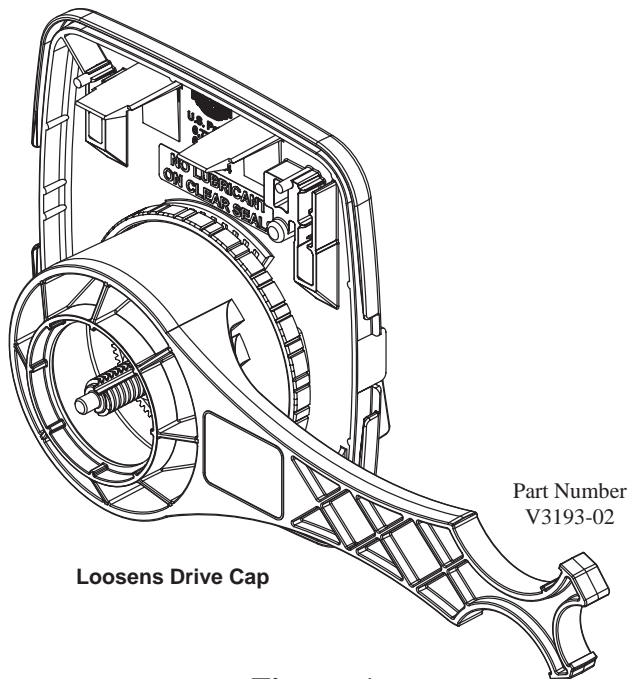

**Figure: 1**

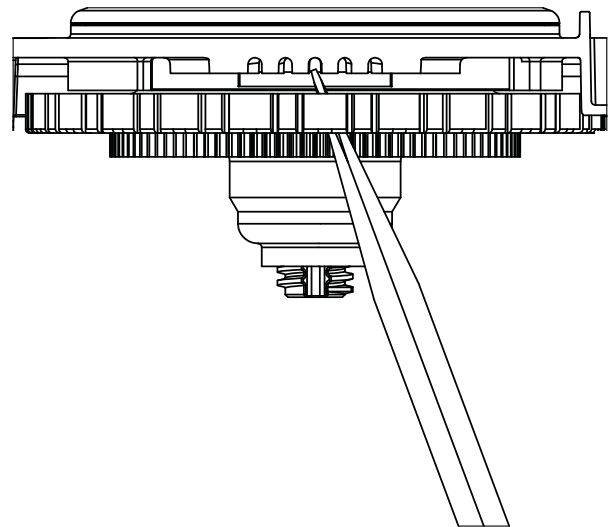

**Figure: 2**

The drive cap assembly contains the drive cap, the main drive gear, drive cap spline, piston rod and various other parts that should not be disassembled in the field. The only replaceable part on the drive cap assembly is the o-ring. Attached to the drive cap assembly is the main piston (down flow) and if a regenerant is used, a regenerant piston.

The regenerant piston (the small diameter one behind the main piston) is removed from the main piston by unsnapping it from its latch. Chemically clean in dilute sodium bisulfite or vinegar or replace the regenerant piston if needed. To remove the main down flow piston fully extend the piston rod and then unsnap the main piston from its latch by pressing on the side with the number. Chemically clean in dilute sodium bisulfite or vinegar, or replace the main piston. The main piston is teflon coated. If the teflon coating is abraded, replace the main piston.

Reattach the main piston to the drive cap assembly. Reattach the regenerant piston (if needed) to the main piston. Do not lubricate the piston rod, main piston or regenerant piston. Lubricant will adversely affect the clear lip seals. Reinsert the drive cap assembly and piston into the spacer stack assembly and hand tighten the drive cap assembly. Continue to tighten the drive cap assembly using a screwdriver as a ratchet or the V3193-01 wrench until the black o-ring on the spacer stack assembly is no longer visible through the drain port. Excessive force can break the notches molded into the drive back plate. Make certain that the main drive gear still turns freely. The exact position of the piston is not important as long as the main drive gear turns freely.

Reattach the drive assembly to the control valve and connect all plugs. After completing any valve maintenance, press and hold NEXT and REGEN buttons for 3 seconds or unplug power source jack (black wire) and plug back in. This resets the electronics and establishes the service piston position. The display should flash all wording, then flash the software version and then reset the valve to the service position.

#### Spacer Stack Assembly

To access the spacer stack assembly remove the drive assembly, drive cap assembly and piston. The spacer stack assembly can be removed easily without tools by using thumb and forefinger. Inspect the black o-rings and clear lip seals for wear or damage. Replace the entire stack if necessary. The spacer stack assembly has been 100% tested at the factory to insure proper orientation of one way seals. Do not disassemble the stack.

The spacer stack assembly may be chemically cleaned (dilute sodium bisulfite or vinegar) or wiped with a soft cloth.

The spacer stack assembly can be pushed into the control valve body bore by hand. Since the spacer stack assembly can be compressed it is easier to use a blunt object (5/8" to 1-1/8" in diameter) to push the center of the assembly into the control valve body. The assembly is properly seated when at least four threads are exposed (approximately 5/8"). Do not force the spacer stack assembly in. The control valve body bore interior can be lubricated with silicone to allow for easy insertion of the entire stack. Do not use silicone or any other type of lubricant on the clear lip seals or the piston.

Reattach the drive cap assembly and piston(s) and the drive assembly.

After completing any valve maintenance, press and hold NEXT and REGEN buttons for 3 seconds or unplug power source jack (black wire) and plug back in. This resets the electronics and establishes the service piston position. The display should flash all wording, then flash the software version and then reset the valve to the service position.

#### Injector Cap, Screen, Injector Plug and Injector

Remove the three bolts from the injector cap and lift off. Remove the screen and clean if fouled.

The injector can be pried out with a small screwdriver. The injector consists of a throat and a nozzle. Chemically clean the injector with vinegar or sodium bisulfite. The holes can be blown out with air. Both pieces have small diameter holes that control the flow rates of water to insure that the proper concentration of regenerant is used. Sharp objects, which can score the plastic, should not be used to clean the injector. Scoring the injector or increasing the diameter of the hole could change the operating parameters of the injector.

If a valve does not use a regenerant the injector plug should not need to be cleaned.

#### Refill Flow Control Assembly or Refill Port Plug

To clean or replace the refill flow control, remove the nut (WS2) or pull out the locking clip (WS1.5 and 2L) and then pull the fitting straight out. Remove the flow control retainer. The flow control can be removed by prying upward through the side slots of the retainer with a small blade flat screwdriver.

Chemically clean the flow control or the flow control retainer using dilute sodium bisulfite or vinegar. Do not use a wire brush. If necessary, replace the flow control, o-ring on the flow control retainer, or the o-ring on the fitting.

Reseat the flow control retainer and reassemble the fitting.

Do not use Vaseline, oils, or other unacceptable lubricants on o-rings. A silicone lubricant may be used on the o-ring on the elbow or the retainer.

Refill port plugs should not need to be serviced. O-rings may be replaced if necessary.



Water Meter

The water meter assembly is connected to the PC board by a wire. If the entire water meter assembly is to be replaced, remove the control valve cover and remove the power source and water meter plugs from the PC board. Unlatch the drive assembly and lean it forward. Unthread the water meter wire from the side of the drive assembly and through the drive back plate. To reinstall, rethread the water meter wire through the drive back plate and the side of the drive assembly. Reattach the drive assembly and the water meter and power plugs.

The water meter wire does not need to be removed from the PC board if the water meter is only being inspected and cleaned. To remove the water meter assembly, remove the meter clip and using a small screwdriver pry up on the meter assembly.

When the meter is part way out it is easy to remove the water meter from the housing. Once the water meter is removed from the meter body, use your fingers to gently pull forward on the turbine to remove it from the shaft.

Do not use a wire brush to clean. Wipe with a clean cloth or chemically clean in dilute sodium bisulfite or vinegar. The turbine can be immersed in the chemical. Do not immerse electronics. If the turbine is scored or damaged or the bearings on the turbine are worn, replace the turbine.

Do not lubricate the turbine shaft. The turbine shaft bearings are prelubricated. Do not use Vaseline, oils, or other unacceptable lubricants on the o-ring. A silicone lubricant may be used on the black o-ring.

Snap the turbine on the shaft and reinsert the water meter into the meter body. Insert the meter clip.

**Table 3  
Troubleshooting Procedures**

Problem	Possible Cause	Solution
1. Timer does not display time of day.	a. Power Adapter unplugged	a. Connect power
	b. No electric power at outlet	b. Repair outlet or use working outlet
	c. Defective Power Adapter	c. Replace Power Adapter
	d. Defective PC board	d. Replace PC board
2. Timer does not display correct time of day	a. Switched outlet	a. Use uninterrupted outlet
	b. Power outage	b. Reset time of day. If battery is present the battery may be depleted. See Front Cover and Drive Assembly drawing for instructions.
	c. Defective PC board.	c. Replace PC board
3. Display does not indicate water is flowing. Refer to user instructions for how the display indicates water is flowing.	a. Bypass valve in bypass position	a. Put bypass valve in service position
	b. Meter connection disconnected	b. Connect meter to PC board
	c. Restricted/stalled meter turbine	c. Remove meter and check for rotation or foreign material
	d. Defective meter	d. Replace meter
	e. Defective PC board	e. Replace PC board
	f. Meter not installed	f. Install meter
	g. PC board incorrectly programmed	g. Refer to programming instructions
4. Control valve regenerates at wrong time of day	a. Power outages	a. Reset time of day. If battery is present the battery may be depleted. See Front Cover and Drive Assembly drawing for instructions.
	b. Time of day not set correctly	b. Reset to correct time of day
	c. Time of regeneration incorrect	c. Reset regeneration time
	d. Control valve set at "on 0" (immediate regeneration)	d. Check control valve set-up procedure regeneration time option
	e. Control valve set at NORMAL + on 0 (delay + immediate regeneration)	e. Check control valve set-up procedure regeneration time option
5. Control valve stalled in regeneration	a. Motor not operating	a. Replace motor
	b. No electric power at outlet	b. Repair outlet or use working outlet
	c. Defective Power Adapter	c. Replace Power Adapter
	d. Defective PC board	d. Replace PC board
	e. Broken drive gear or drive cap assembly	e. Replace drive gear or cap assembly
	f. Broken piston retainer	f. Replace drive cap assembly
	g. Broken main or regenerant piston	g. Replace main or regenerant piston
6. Control valve does not regenerate automatically when the correct button(s) is depressed and held. For TC valves the buttons are UP and DOWN. For all other valves the button is REGEN.	a. Power Adapter unplugged	a. Connect Power Adapter
	b. No electric power at outlet	b. Repair outlet or use working outlet
	c. Broken drive gear or drive cap assembly	c. Replace drive gear or drive cap assembly
	d. Defective PC board	d. Replace PC board
7. Control valve does not regenerate automatically but does when the correct button(s) is depressed and held. For TC valves the buttons are UP and DOWN. For all other valves the button is REGEN.	a. Bypass valve in bypass position	a. Put bypass valve in normal operation position
	b. Meter connection disconnected	b. Connect meter to PC board
	c. Restricted/stalled meter turbine	c. Remove meter and check for rotation or foreign matter
	d. Defective meter	d. Replace meter
	e. Defective PC board	e. Replace PC board
	f. Set-up error	f. Check control valve set-up procedure
8. Time of day flashes on and off	a. Power outage	a. Reset time of day. If battery is present the battery may be depleted. See Front Cover and Drive Assembly drawing for instructions.

Problem	Possible Cause	Solution
<p>9. Error Codes</p> <p>101, 1001 or E1 – Unable to recognize start of regeneration</p> <p>102, 1002 or E2 – Unexpected stall</p> <p>103, 1003 or E3 – Motor ran to long, timed out trying to reach next cycle position</p> <p>104, 1004 or E3 – Motor ran to long, timed out trying to reach home position</p> <p>If other error codes display contact the factory</p>	a. Control valve has just been serviced	<p>a. Unplug power source jack from the printed circuit board (black wire) and plug back in or press button sequence to reset valves: TC valves (three buttons) press and hold SET and DOWN buttons for 3 seconds. (Cover button may have other names like “SET HOUR “, “CLOCK” or “SET CLOCK” but the circuit board is labeled with SET.) All other valves press and hold NEXT and REGEN buttons for 3 seconds.</p>
	b. Foreign matter is lodged in control valve	b. Check piston and spacer stack assembly for foreign matter
	c. High drive forces on piston	c. Replace piston(s) and spacer stack assembly
	d. Control valve piston not in home position	<p>d. Unplug power source jack from the printed circuit board (black wire) and plug back in or press button sequence to reset valves: TC valves (three buttons) press and hold SET and DOWN buttons for 3 seconds. (Cover button may have other names like “SET HOUR “, “CLOCK” or “SET CLOCK” but the circuit board is labeled with SET.) All other valves press and hold NEXT and REGEN buttons for 3 seconds.</p>
	e. Motor not inserted fully to engage pinion, motor wires broken or disconnected, motor failure	e. Check motor and wiring. Replace motor if necessary
	f. Drive gear label dirty or damaged, missing or broken gear	f. Replace or clean drive gear
	g. Drive bracket incorrectly aligned to back plate	g. Reseat drive bracket properly
	h. PC board is damaged or defective	h. Replace PC board
	i. PC board incorrectly aligned to drive bracket	i. Ensure PC board is correctly snapped on to drive bracket
	<p>10. Error Codes for MAV and NHWB</p> <p>106 or 1006 – MAV/NHWB unable to find proper park position, motor ran too long.</p> <p>107 or 1007 – MAV/NHWB motor ran too short (stalled) while looking for proper park position</p> <p>If other error codes display contact the factory</p>	a. Foreign matter is lodged in MAV/NHWB
b. High drive forces on MAV/NHWB piston		b. Replace MAV/NHWB piston and spacer stack assembly
c. MAV/NHWB motor not inserted fully to engage pinion, motor wires broken or disconnected, motor failure		c. Check MAV/NHWB motor and wiring. Check interconnect wiring to both PC boards. Replace motor or wiring if necessary.
d. MAV/NHWB drive gear damaged, missing or broken gear		d. Replace MAV/NHWB drive cap.
e. MAV/NHWB main gear cover assembly incorrectly aligned to drive assembly.		e. Reseat MAV/NHWB main gear cover assembly properly
f. PC board is damaged or defective		f. Replace PC board

VIOLET, ORDER NO. V3010-15B  
or V3010-2R-15B  
Metric Units

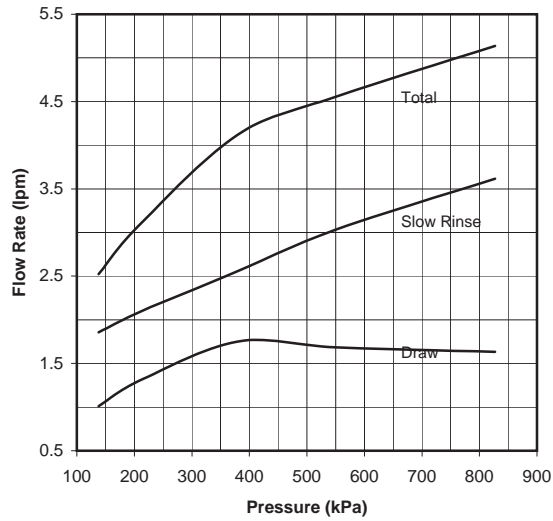

VIOLET, ORDER NO. V3010-15B  
or V3010-2R-15B  
US Units

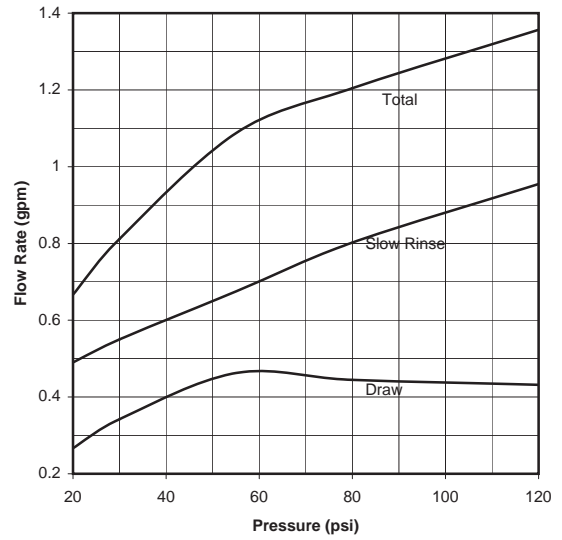

RED, ORDER NO. V3010-15C  
or V3010-2S-15C  
Metric Units

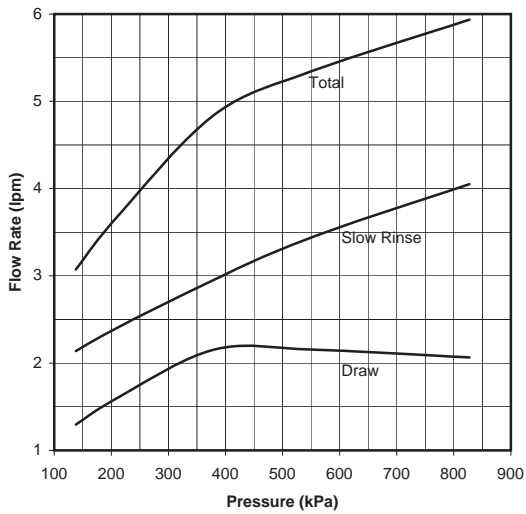

RED, ORDER NO. V3010-15C  
or V3010-2S-15C  
US Units

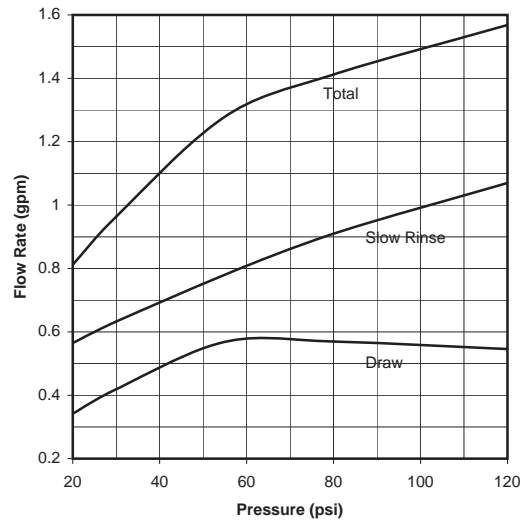

WHITE, ORDER NO. V3010-15D  
or V3010-2T-15D  
Metric Units

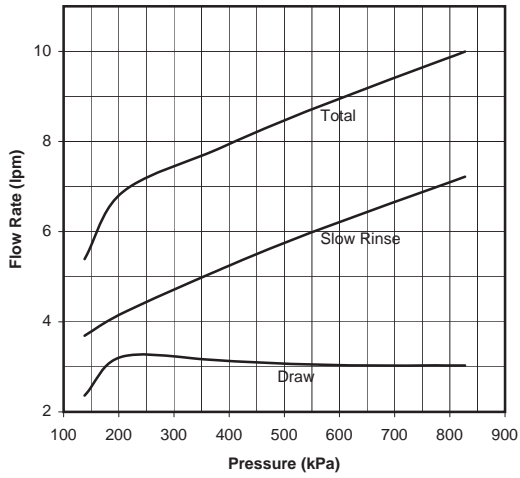

WHITE, ORDER NO. V3010-15D  
or V3010-2T-15D  
US Units

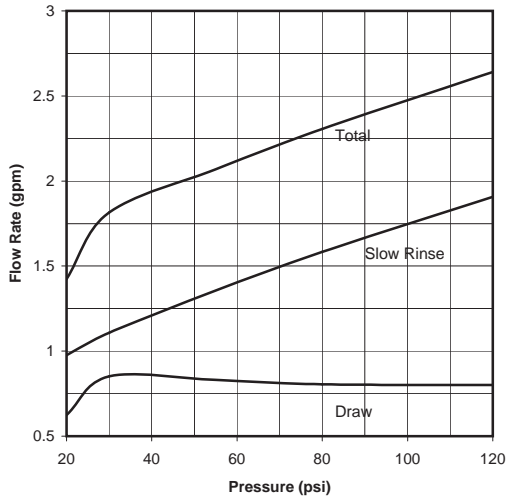

BLUE, ORDER NO. V3010-15E  
or V3010-2U-15E  
Metric Units

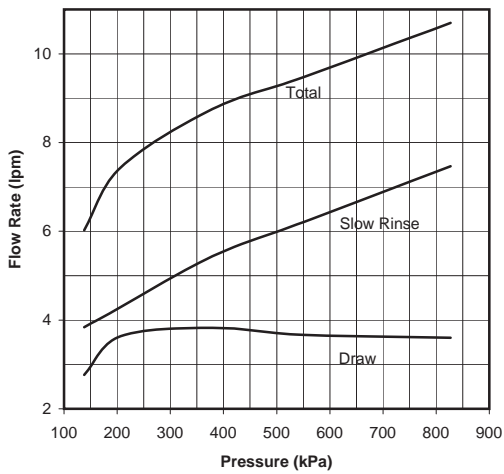

BLUE, ORDER NO. V3010-15E  
or V3010-2U-15E  
US Units

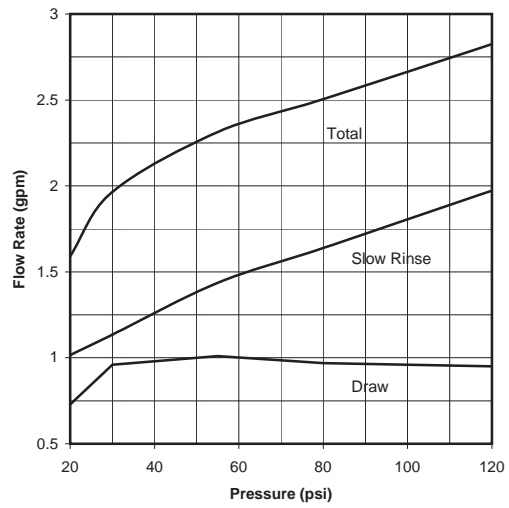

YELLOW, ORDER NO. V3010-15F  
or V3010-2V-15F  
Metric Units

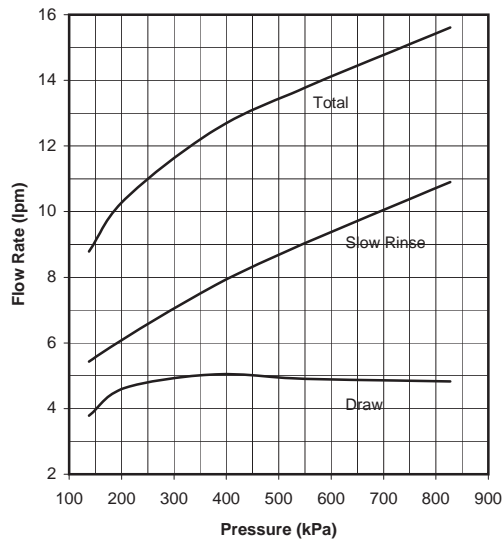

YELLOW, ORDER NO. V3010-15F  
or V3010-2V-15F  
US Units

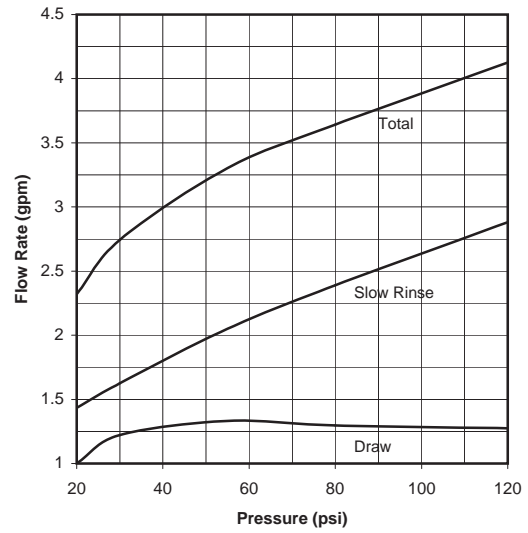

GREEN, ORDER NO. V3010-15G  
or V3010-2W-15G  
Metric Units

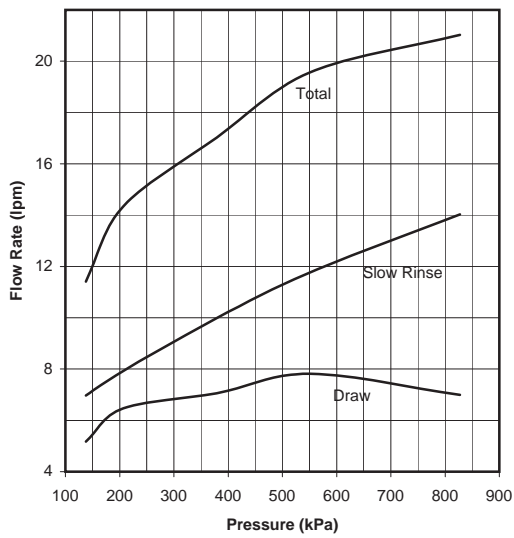

GREEN, ORDER NO. V3010-15G  
or V3010-2W-15G  
US Units

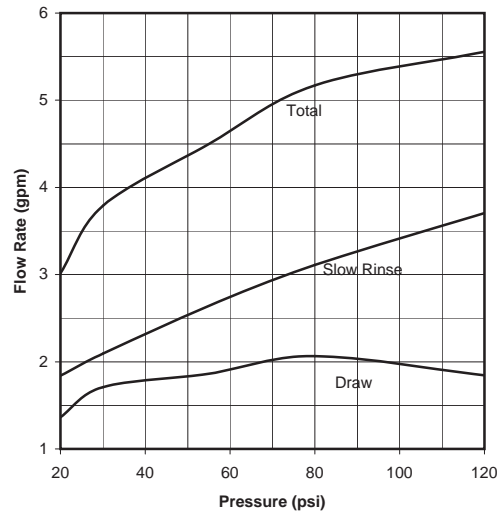

ORANGE, ORDER NO. V3010-15H  
or V3010-2X-15H  
Metric Units

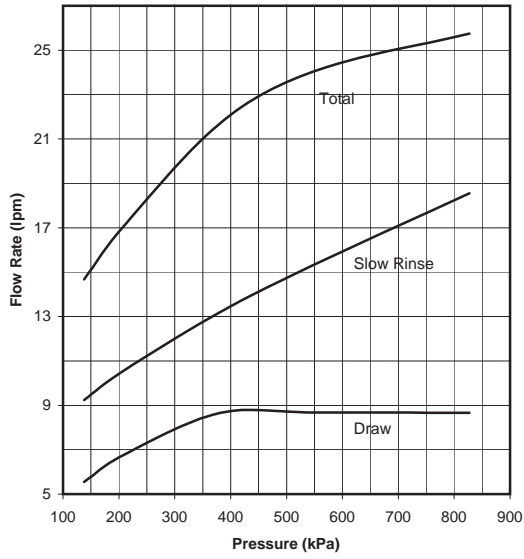

ORANGE, ORDER NO. V3010-15H  
or V3010-2X-15H  
US Units

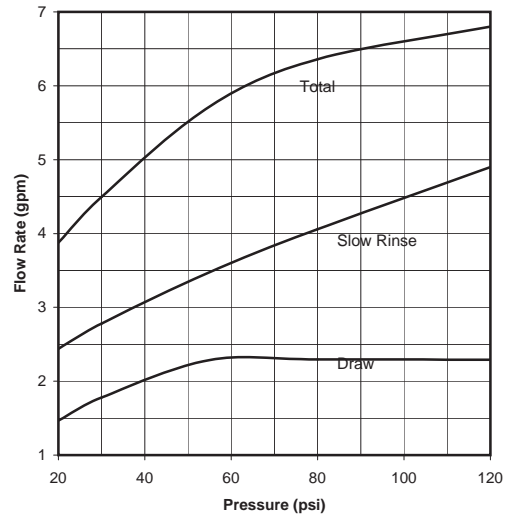

**Order No. V3010-2A  
US Units**

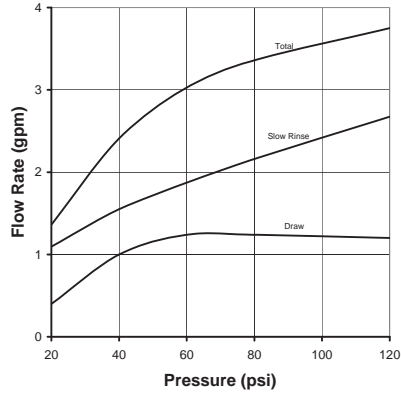

**Order No. V3010-2B  
US Units**

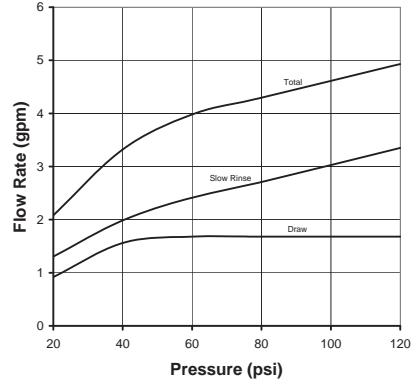

**Order No. V3010-2C  
US Units**

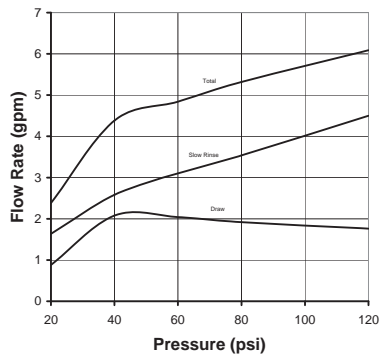

**Order No. V3010-2D  
US Units**

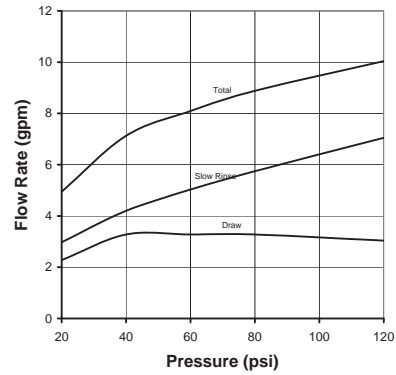

**Order No. V3010-2E  
US Units**

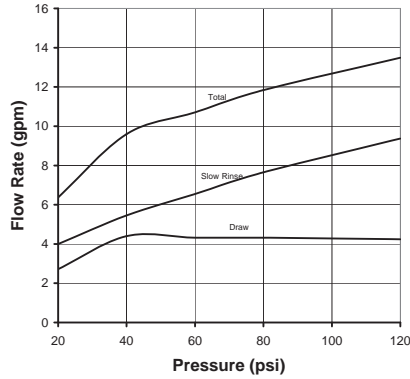

**Order No. V3010-2F  
US Units**

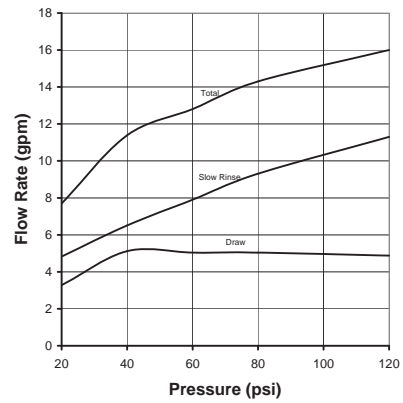

**Order No. V3010-2G  
US Units**

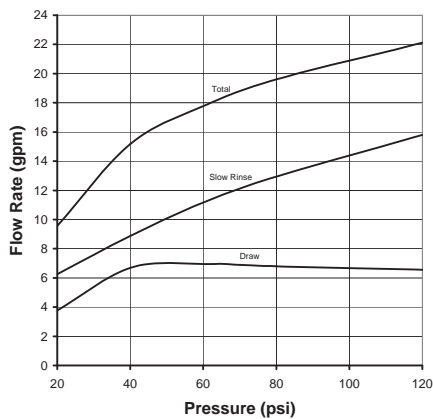



**Order No. V3010-2A  
Metric Units**

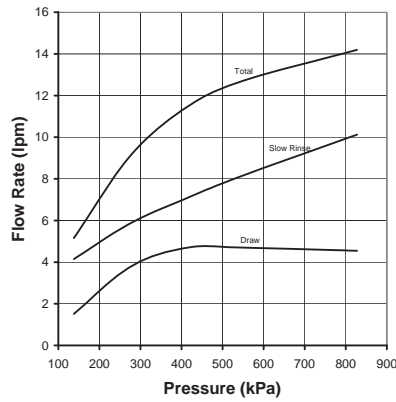

**Order No. V3010-2B  
Metric Units**

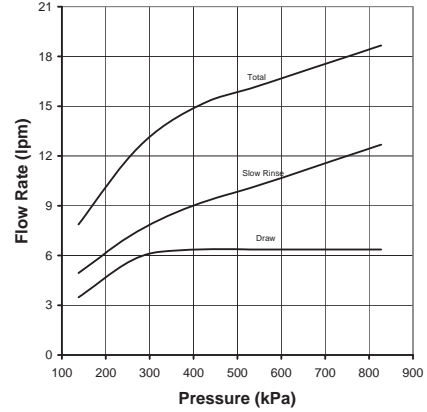

**Order No. V3010-2C  
Metric Units**

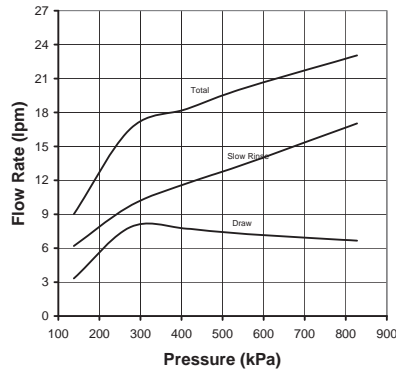

**Order No. V3010-2D  
Metric Units**

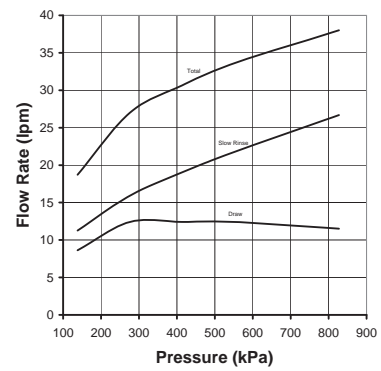

**Order No. V3010-2E  
Metric Units**

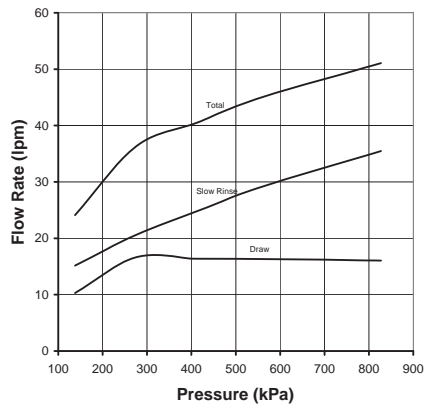

**Order No. V3010-2F  
Metric Units**

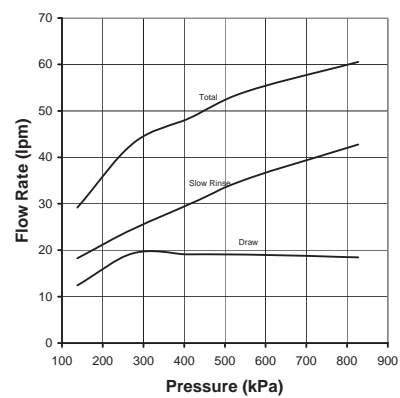

**Order No. V3010-2G  
Metric Units**

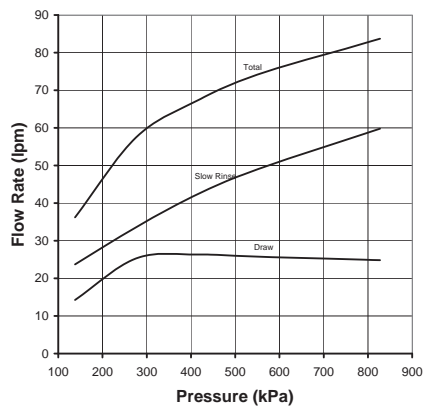

**Revision History:****5/21/08****PAGE 4-11:**

Included drawings and part numbers for parts common to all valves.

**6/5/08****PAGE 4 & 6:**

Added meter retaining clip installation drawing.

**8/1/08****PAGES 6, 9, 13, 16, 17, 18, 22, 30 & 31:**

Added 2" Valve information.

**8/19/08****PAGES 4 & 7:**

Revised turbine servicing instructions.

**9/08/08****PAGE 7:**

Added

**OPERATING PRESSURES: 20 PSI MINIMUM / 125 PSI MAXIMUM • OPERATING TEMPERATURES: 40°F MINIMUM / 110°F MAXIMUM****10/3/08****PAGES 14-16:**

Added DLFC, Drain Elbow and Drain Fitting information.

**11/25/08****PAGE 9:**

Added new 2" Valve Injector information.

**PAGES 15-16:**

V3158-04 WS2 Drain Elbow 3/4" Male NPT Without Silencer

V3008-05 WS2 Fitting Drain 1" Male NPT Straight Without Silencer

**PAGE 21:**

Added new 2" Valve Injector information.

**PAGES 29-32:**

Added new 2" Valve Injector information.

**CLACK CORPORATION**  
**FIVE-YEAR SOFTENER AND FILTER CONTROLS**  
**LIMITED WARRANTY**

Clack Corporation (“Clack”) warrants to OEM that its Softener and Filter Control Valves will be free from defects in material and workmanship under normal use and service for a period of five years from the date of shipment of such Valves from Clack’s plant in Windsor, Wisconsin when installed and operated within recommended parameters. No warranty is made with respect to defects not reported to Clack within the warranty period and/or defects or damages due to neglect, misuse, alterations, accident, misapplication, physical damage, or damage caused by fire, acts of God, freezing or hot water or similar causes. For outdoor installations where the Softener and Filter Control Valves are not under cover, the weather cover must be utilized for the warranty to be valid.

Clack’s obligation to OEM under this Limited Warranty shall be limited, at its option, to replacement or repair of any Softener and Filter Control valve covered by this Limited Warranty. Prior to returning a Control Valve, OEM must obtain a return goods authorization number from Clack and return the Control Valve freight prepaid. If any Control Valve is covered under this Limited Warranty, Clack shall return the Control Valve repaired, or its replacement, prepaid to the original point of shipment.

**CLACK GIVES THIS WARRANTY TO OEM IN LIEU OF ALL OTHER WARRANTIES, EXPRESS OR IMPLIED, INCLUDING WITHOUT LIMITATION ANY IMPLIED WARRANTIES OF MERCHANTABILITY OR FITNESS FOR A PARTICULAR PURPOSE AND HEREBY EXPRESSLY DISCLAIMS ALL OTHER SUCH WARRANTIES. CLACK’S LIABILITY HEREUNDER SHALL NOT EXCEED THE COST OF THE PRODUCT. UNDER NO CIRCUMSTANCES WILL CLACK BE LIABLE FOR ANY INCIDENTAL OR CONSEQUENTIAL DAMAGES OR FOR ANY OTHER LOSS, DAMAGE OR EXPENSE OF ANY KIND, INCLUDING LOSS OF PROFITS, ARISING IN CONNECTION WITH THE INSTALLATION OR USE OR INABILITY TO USE THE CONTROL VALVES OR ANY WATER TREATMENT SYSTEM THE CONTROL VALVE IS INCORPORATED INTO.**