

Water Specialist 1” Control Valve Series Model: WS1TC

Operation and Instruction Manual for OEM Only.

Please Note: This operation and instruction manual is for the training of the OEM and for the OEM to use to train their customers. This document is not to be used as the complete system manual.

MANUAL REGENERATION

NOTE: For softeners, if brine tank does not contain salt, fill with salt and wait at least 2 hours before regeneration.

If you need to initiate a manual regeneration, either immediately, or tonight at the preprogrammed time (typically 2 a.m.), complete the following steps.

For Immediate Regeneration:

Press and hold UP and DOWN simultaneously until valve motor starts (typically 3 seconds).

For Regeneration Tonight:

Press and release UP and DOWN simultaneously (notice that arrow points to Regen).

Arrow will point to Regen if a regeneration is expected "Tonight."

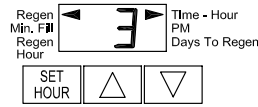

If the display shows "E1," "E2" or "E3" (for error), call a service technician.

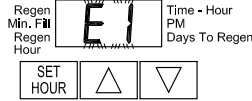

To shut off water to the system, please position arrow handles as shown in the **bypass operation** diagram below. If your valve doesn't look like the diagram below, contact your service technician for instructions on how to shut off water.

NORMAL OPERATION

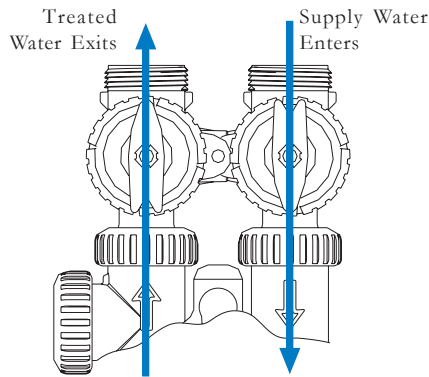

BYPASS OPERATION

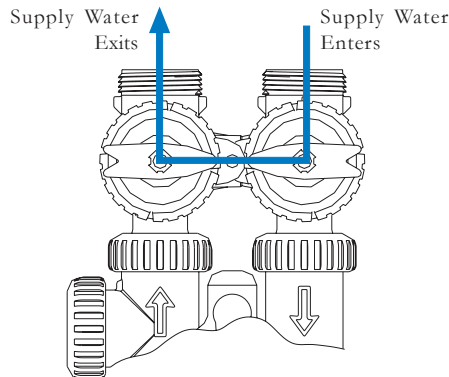

GENERAL OPERATION

When the system is operating one of two displays will be shown: time of day or days until the next regeneration. Pressing UP or DOWN will toggle between the two choices.

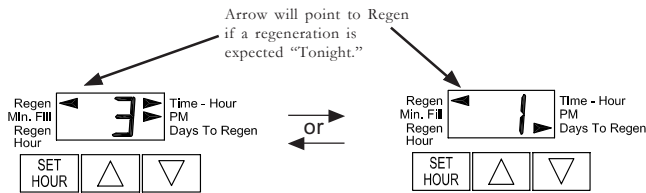

TO SET TIME OF DAY

In the event of a power outage, time of day needs to be reset. All other information will be stored in memory no matter how long the power outage. Please complete the steps as shown to the right. To access this mode, press SET HOUR.

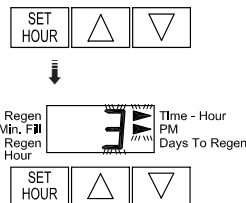

1. Accessed by pressing SET HOUR.
2. Adjust to the nearest hour using UP or DOWN. An arrow points to PM during p.m. hours.
3. Press SET HOUR to complete and return to normal operation.

TO SET TIME OF REGENERATION

For initial set-up or to make adjustments, please complete the steps as shown to the right. Access this mode by pressing SET HOUR and UP simultaneously for 3 seconds.

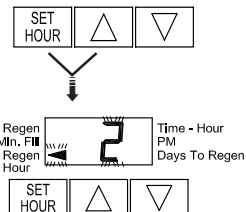

1. Accessed by pressing SET HOUR and UP simultaneously for 3 seconds.
2. Adjust time of regeneration hour using the UP or DOWN. An arrow points to PM during p.m. hours. Simultaneously press SET HOUR and DOWN to return to normal operation.

Table of Contents

Introduction	4
General Warnings (Must appear in OEM's manual)	4
Specifications which must be included in OEM's Manual	5
Quick Reference Specifications	5
Control Valve Function and Cycles of Operation	6
Drive Assembly	8
Drive Cap Assembly, Downflow Piston and Regenerant Piston	8
Spacer Stack Assembly	8
Injector Cap, Screen, Injector Plug and Injector	9
Refill Flow Control Assembly or Refill Port Plug	9
Drain Line Flow Control and Fitting Assembly	10
Installation Fitting Assemblies	11
Bypass Valve	12
OEM General Instructions	14
OEM System Setup	14
Installer Displays/Settings	16
User Displays/Settings	17
Installation	18
Drawings and Part Numbers	20
Front Cover and Drive Assembly	21
Drive Cap Assembly, Downflow Piston, Regenerant Piston and Spacer Stack Assembly	22
Injector Cap, Injector Screen, Injector, Plug and O-ring	23
Refill and Refill Port Plug	24
Drain Line – 3/4"	25
Drain Line – 1"	26
Meter Plug	27
Installation Fitting Assemblies	28
Bypass Valve	29
Flow Diagrams – Service and Backwash	30
Flow Diagrams – Downflow Brine and Rinse	31
Flow Diagrams – Fill	32
WS1 Wrench (Order No. V3193)	33
Service Instructions	34
Troubleshooting	38
Injector Graphs US Units: Injector Draw, Slow Rinse and Total Flow Rates	39
Injector Graphs Metric Units: Injector Draw, Slow Rinse and Total Flow Rates	41
Limited Warranty	43

Introduction

This manual is about a control valve to be used on water softeners or water filters. The manual is designed to aid water treatment equipment manufacturers in the selection of the various control valve options. Information in this manual is different than what is needed for installation and servicing of a particular water treatment system. This manual is not intended to be used as a manual for a complete water softener or filter. Certain parts of the manual will serve as aids to manufacturers in the writing and layout of the manuals for installers and service personnel.

General Warnings *(Must appear in OEM's manual)*

The following general warnings and the specifications in Table 1 must appear in the OEM's System Manual.

The control valve, fittings and/or bypass are designed to accommodate minor plumbing misalignments but are not designed to support the weight of a system or the plumbing.

Do not use Vaseline, oils, other hydrocarbon lubricants or spray silicone anywhere. A silicon lubricant may be used on black o-rings but is not necessary. **Avoid any type of lubricants, including silicone, on red or clear lip seals.**

The nuts and caps are designed to be unscrewed or tightened by hand or with the special plastic wrench. If necessary a pliers can be used to unscrew the nut or cap. Do not use a pipe wrench to tighten or loosen nuts or caps. Do not place screwdriver in slots on caps and/or tap with a hammer.

Do not use pipe dope or other sealants on threads. Teflon tape must be used on the threads of the 1" NPT elbow or the ¼" NPT connection and on the threads for the drain line connection. Teflon tape is not necessary on the nut connection or caps because of o-ring seals.

After completing any valve maintenance involving the drive assembly or the drive cap assembly and pistons, unplug power source jack from the printed circuit board (black wire) and plug back in. This resets the electronics and establishes the service piston position.

All plumbing should be done in accordance with local plumbing codes. The pipe size for the drain line should be a minimum of ½". Backwash flow rates in excess of 7 gpm or length in excess of 20' require ¾" drain line.

Solder joints near the drain must be done prior to connecting the drain line flow control fitting. Leave at least 6" between the drain line control fitting and solder joints when soldering pipes that are connected on the drain line control fitting. Failure to do this could cause interior damage to the drain line flow control fitting.

When assembling the installation fitting package (inlet and outlet), connect the fitting to the plumbing system first and then attach the nut, split ring and o-ring. Heat from soldering or solvent cements may damage the nut, split ring or o-ring. Solder joints should be cool and solvent cements should be set before installing the nut, split ring and o-ring. Avoid getting primer and solvent cement on any part of the o-rings, split rings, bypass valve or control valve.

Plug into an electrical outlet. Note: All electrical connections must be connected according to local codes. (Be certain the outlet is uninterrupted.)

Install grounding strap on metal pipes.

Table 1
Specifications which must be included in OEM's Manual

Minimum/Maximum Operating Pressures	20 psi (138 kPa) -125 psi (862 kPa)
Minimum/Maximum Operating Temperatures	40°F (4°C) -110°F (38°C)
Current Draw & Voltage	0.5 Amperes 110 Volts Other options available

Table 2 contains a summary of specifications for the control valve and bypass valve.

Table 2
Quick Reference Specifications

Service flow rate (includes bypass)	27 gpm (102.2 lpm) @ 15 psig (103 kPa) drop
Backwash flow rate (includes bypass)	27 gpm (102.2 lpm) @ 25 psig (172 kPa) drop
Minimum/Maximum Operating Pressures	20 psi (138 kPa) -125 psi (862 kPa)
Minimum/Maximum Operating Temperatures	40°F (4°C) -110°F (38°C)
Current Draw & Voltage	0.5 Amperes 110 Volts Other options available
Regenerant Refill Rate	0.5 gpm (1.9 lpm)
Injectors	See Injector Graphs
Drain Line Flow Controls	See Table 5
Inlet / Outlet Fitting Options	(a) 1" NPT elbow which has a unique drill out feature to allow a 1/4" NPT connection to the inlet and/or outlet (b) 3/4" & 1" PVC solvent weld fitting (c) 1" straight brass sweat fitting (d) 3/4" straight brass sweat fitting
Distributor Tube Opening	1.05" Diameter (3/4" U.S. PVC Pipe Size)
Tank Thread	2-1/2" – 8 NPSM
Control Valve Weight	4.5 lbs 2.0 kg
PC Board Memory	Nonvolatile EEPROM (electrically erasable programmable read only memory)
Compatible with regenerants/chemicals	Sodium chloride, potassium chloride, potassium permanganate, sodium bisulfite, sodium hydroxide, hydrochloric acid, chlorine and chloramines

Control Valve Function and Cycles of Operation

This glass filled Noryl¹ fully automatic control valve is designed as the primary control center to direct and regulate all cycles of a water softener or filter.

The time clock control valve can be set to perform downflow regeneration or simply backwash. The time clock control valve has two calendar options for regeneration frequency:

1. an option where the user can choose the number of days (1-99) between each regeneration; and
2. a seven-day option where the user can choose which day(s) of the week a regeneration should occur.

The control valve is compatible with a variety of regenerants and resin cleaners. The control valve is capable of routing the flow of water in the necessary paths to regenerate or backwash water treatment systems. The injector regulates the flow of brine or other regenerants. The control valve regulates the flow rates for backwashing, rinsing, and the replenishing of treated water into a regenerant tank, when applicable.

The control valve is designed to deliver high service (27 gpm @ 15 psig) and backwash (27 gpm @ 25 psig) flow rates when the bypass has straight fittings. The control valve uses no traditional fasteners (e.g. screws), instead clips, threaded caps and nuts and snap type latches are used. Caps and nuts only need to be firmly hand tightened because radial seals are used. Tools required to service the valve include one small blade screw driver, one large blade screw driver, pliers and a pair of hands. A plastic wrench is available which eliminates the need for screwdrivers and pliers. Disassembly for servicing takes much less time than comparable products currently on the market. Control valve installation is made easy because the distributor tube can be cut ½" above to ½" below the top of tank thread. The distributor tube is held in place by an o-ring seal and the control valve also has a bayonet lock feature for upper distributor baskets.

The transformer power pack comes with a 15 foot power cord and is designed for use with the control valve. The transformer power pack is for dry location use only. If the power goes out, only the time of day needs to reset. All other values are permanently stored in the nonvolatile memory.

Table 3 shows the time for the backwash, regenerative, and rinse cycles for the ten available programming options. Six different programs are available for a softener, one for a regenerative filter, and three programs for backwash only filters. When the control valve is used as a:

1. softener, one or two backwashes occur and refill always occurs after the rinse cycle (P0 through P5);
2. regenerative filter, one backwash occurs and refill always occurs after the rinse cycle (P6); and
3. backwashing filter, one backwash occurs (P7 through P9).

Table 3
Regeneration Cycles and Times for Different Programs

Program	All Times in Minutes				
	C1 1 st Backwash	C2 Regenerate	C3 2 nd Backwash	C4 Rinse	C5 Fill
P0	3	50	3	3	1-99
P1	8	50	8	4	1-99
P2	8	70	10	6	1-99
P3	12	70	12	8	1-99
P4	10	50	Skipped	8	1-99
P5	4	50	Skipped	4	1-99
P6	12	6	Skipped	12	1-99
P7	6	Skipped	Skipped	4	Skipped
P8	10	Skipped	Skipped	6	Skipped
P9	14	Skipped	Skipped	8	Skipped

Note: During regeneration the display will show C1, C2, etc. If the cycle is skipped, that cycle number will not be displayed.

¹ Noryl is a trademark of General Electric.

The user can initiate manual regeneration. The user has the option to request the manual regeneration at the delayed regeneration time or to have the regeneration occur immediately. Simultaneously press the UP + DOWN buttons to start a regeneration at the next delayed regeneration time. If a regeneration is to occur today an arrow will point to regeneration. For immediate regeneration, simultaneously press and hold the UP + DOWN buttons for three seconds.

When in regeneration step through the different regeneration cycles by simultaneously pressing the UP + DOWN buttons.

The control valve consists of the following components:

1. Drive Assembly
2. Drive Cap Assembly, Main Piston and Regenerant Piston
3. Spacer Stack Assembly
4. Injector Cap, Screen, Injector Plug and Injector
5. Refill Flow Control Assembly or Refill Port Plug
6. Drain Line Flow Control and Fitting Assembly
7. Installation Fitting Assemblies
8. Bypass Valve (optional)

Drive Assembly

The drive assembly consists of the following parts:

- Drive Bracket
- Printed Circuit (PC) Board
- Motor
- Drive Gears
- Drive Gear Cover

The drive bracket holds the PC board, the motor, the drive gears and the drive gear cover in place.

The PC board receives and retains information, displays the information, determines when to regenerate and initiates regeneration.

The PC board powers the motor. The PC board's two-prong jack connects wires to the direct current (DC) motor. The motor is held in place on the drive bracket by a spring-loaded clip and a small bulge in the plastic, which fits in one of the slots on the motor housing. The motor turns drive gears that drive the piston to cycle positions for backwashing, regeneration, rinsing, refill or service. The motor is fully reversible (turns both ways) and changes direction of rotation to change the direction of piston motion. The motor is easily replaced if necessary.

There are three drive gears held in place by the drive gear cover. All three drive gears are the same size. A reflective coating is applied to the gears. As the center drive gear turns a light shines on the coating and a light sensing diode determines if a light pulse was returned. The PC board counts the pulses and determines when to stop driving the motor.

Drive Cap Assembly, Downflow Piston and Regenerant Piston

The drive gears turn the main gear of the drive cap assembly, which moves the piston. The screw-driven, horizontally moving piston stops at specific positions to direct the flow of water to backwash, regenerate, rinse or refill. The PC board determines the position of the piston by counting pulses produced when the piston is moved. An optical sensor looking at one of the reduction drive gears generates these pulses. Each cycle position is defined by a number of pulses. The counter is zeroed each time the valve goes to the service position. The PC board finds the service position by noting the increase in current delivered to the motor when the mechanical stop at the service position is reached. This method of controlling piston position allows for greater flexibility and requires no switches or cams.

The downflow piston is used when the control valve is used as a down flow softener, regenerating filter or non-regenerating filter. If the control valve is used as a softener or a regenerating filter, a regenerant piston must be attached to the downflow piston. If the control valve is to be used on system that does not require a regenerant to be added the regenerant piston must be removed.

Spacer Stack Assembly

The spacer stack assembly provides the necessary flow passage for water during the different cycles. The all plastic spacer stack assembly (patent pending) is a one piece design which allows the stack to be removed using your fingers.

The exterior of the stack is sealed against the body bore with self lubricating EPDM o-rings while the interior surface is sealed against the piston using slippery self cleaning directional (one-way) silicone lip seals. The lip seals are clear and have a special slippery coating so that the piston does not need to be coated or lubricated.

Injector Cap, Screen, Injector Plug and Injector

The screen, injector and/or injector plug(s) are installed under the injector cap in an easy to access location on top of the valve. The injector cap contains four slots so no water accumulates in the cap. The injector cap is designed to be hand tightened.

Under the injector cap there is an easy to clean removable screen to prevent fouling of the injector. There are two holes under the injector cap labeled “DN” and “UP”. The holes will be filled with a plug or an injector.

The plug (Order # V3010-1Z) prevents water from traveling a certain pathway. The injector lets water pass through the pathway. The self-priming injector increases the velocity of the water, creating a zone of negative pressure that draws in the concentrated liquid regenerant, such as sodium chloride (brine), potassium permanganate, sodium hydroxide, hydrochloric acid, etc. The regenerant blends with the stream of water, which passes through the media to regenerate the bed.

The injector provides a consistent regenerant/water mixture ratio over the entire operating pressure range of the control valve. The injector provides good performance in a variety of applications, which may involve elevated drain lines and long regenerant draw lengths. Injectors are chosen by knowing the type, amount, and regenerant flow rate for a particular type of media. Guidelines can be found in the media manufacturer’s literature. The color coded injectors give different regenerant draw, slow rinse and total flow rates over the pressure range. See Table 4 for color codings and injector graphs for total, slow rinse and draw flow rates.

**Table 4
Injector Order Information**

Injector Order Number	Injector Color	Typical Tank Diameter ²
		Down Flow Brining
V3010-1A	Black	6”
V3010-1B	Brown	7”
V3010-1C	Violet	8”
V3010-1D	Red	9”
V3010-1E	White	10”
V3010-1F	Blue	12”
V3010-1G	Yellow	13”
V3010-1H	Green	14”
V3010-1I	Orange	16”
V3010-1J	Light Blue	18”
V3010-1K	Light Green	21”

The control valve has been designed so that the OEM can rapidly change the control valve to allow for the following options:

- regeneration down flow (for softeners or regenerating filters install injector in DN location, plug in Up location); or
- no regeneration (both the DN and UP holes have injector plugs installed) and plug installed for the refill elbow.

Refill Flow Control Assembly or Refill Port Plug

The refill flow control assembly consists of a refill flow elbow, refill flow control retainer assembly, refill flow control, polytube insert and nut assembly. The refill flow control retainer fits in the refill elbow. The refill flow control retainer houses the refill flow control which controls the flow rate when the regenerant tank is being refilled. The refill flow control is a flexible washer-like part with a small orifice and a precision molded contour that delivers a steady 0.5 gpm regenerant tank refill rate at varying inlet pressures. Refill is accomplished with treated water.

² Actual tank size used may vary depending on the design and application of the system. Tank diameter is an approximation for a downflow softener using standard mesh synthetic cation exchange media regenerating with sodium chloride. The actual tank size used may vary depending on the design and application of the system.

The refill flow control assembly is installed in an easy to access refill elbow located on top of the control valve. The refill flow control assembly is attached to the control valve with a locking clip. The locking clip allows the elbow to rotate 270 degrees so the outlet can be orientated towards the regenerant tank.

The control valve has a standard refill elbow to which a 3/8" flexible tube can be connected. An optional elbow can be ordered which accommodates a 1/2" flexible tube for a high regenerant draw rate situation (G injectors and larger). Both elbows use the same refill flow control and retainer.

If the control valve is to be used as a non-regenerant filter control valve, the refill elbow is removed and replaced with a refill port plug.

Drain Line Flow Control and Fitting Assembly

The drain line flow control assembly includes a drain line flow control and a fitting. The drain line flow control allows proper media bed expansion by regulating the flow rate to the drain. The drain line flow control is a flexible washer-like part with an orifice and a precision molded contour. The flow rates are within $\pm 10\%$ over the pressure range of 20 psi to 125 psi.

The flexible washer-like parts are identified with three numbers, which correspond to the flow rate in gallons per minute. See Table 5.

Table 5
Drain Line Flow Control and Fitting Assembly Information

Drain Line Fitting	Drain Line Flow Control Order No.	Number on Drain Line Flow Control	Backwash Flow Rate (gpm)	Backwash Flow Rate (lpm)
3/4"	V3162-007	007	0.7	2.6
3/4"	V3162-010	010	1.0	3.8
3/4"	V3162-013	013	1.3	4.9
3/4"	V3162-017	017	1.7	6.4
3/4"	V3162-022	022	2.2	8.3
3/4"	V3162-027	027	2.7	10.2
3/4"	V3162-032	032	3.2	12.1
3/4"	V3162-042	042	4.2	15.9
3/4"	V3162-053	053	5.3	20.1
3/4"	V3162-065	065	6.5	24.6
3/4"	V3162-075	075	7.5	28.4
3/4"	V3162-090	090	9.0	34.1
3/4"	V3162-100	100	10.0	37.9
1"	V3190-090	090	9.0	34.1
1"	V3190-100	100	10.0	37.9
1"	V3190-110	110	11	41.6
1"	V3190-130	130	13	49.2
1"	V3190-150	150	15	56.8
1"	V3190-170	170	17	64.3
1"	V3190-200	200	20	75.7
1"	V3190-250	250	25	94.6

The drain line flow control and fitting are located on top of the control valve and replaceable without the use of special tools.

The drain line flow control can be installed in the standard 3/4" drain line elbow, which accommodates 5/8" polytube or 3/4" NPT drain line connections. The optional nut and polytube insert for the 3/4" drain line elbow is designed for use with flexible polytube only. The 3/4" drain line elbow can be rotated 180 degrees so the outlet can be orientated to the nearest drain. The same retainer is used for all drain line flow controls for the 3/4" fitting. Drain line flow controls designed for the 3/4" fitting are available for flow rates ranging from 0.7 to 10 gpm.

An optional 1" straight drain line fitting is available to accommodate drain line flow rates ranging from 9 to 25 gpm. This fitting is straight but still connects to the control valve using the same locking clip. The drain line flow control is located between two fitted parts (i.e. the fitting acts as the retainer). The nut is unscrewed to access the drain line flow control.

Installation Fitting Assemblies

The installation fittings are used to connect the optional bypass or the control valve to the plumbing system. There are four installation fitting assemblies available:

1. 1" NPT elbow
2. 3/4" & 1" PVC solvent weld elbow fitting
3. 1" straight brass sweat fitting³
4. 3/4" straight brass sweat fitting³

Both elbow fittings have a unique drill out feature to allow a 1/4" NPT connection to the inlet and/or outlet which can be used for a RO feed, test ports, pressure tap ports, etc.

The installation fitting assemblies are sold in pairs and consist of two fittings, two nuts, two split rings and two o-rings. The installation fitting assemblies and the bypass valve are sold separately from the control valve.

³ Has not been tested for compliance with California Proposition 65, so this fitting should not be installed in California.

Bypass Valve

The bypass valve is typically used to isolate the control valve from the plumbing system's water pressure in order to perform control valve repairs or maintenance. The WS1 bypass valve is particularly unique in the water treatment industry due to its versatility and state of the art design features. The 1" full flow bypass valve incorporates four positions including a diagnostic position that allows service personal to work on a pressurized system while still providing untreated bypass water to the facility or residence. Its completely non-metallic, all plastic design allows for easy access and serviceability without the need for tools.

The bypass body and rotors are glass filled Noryl and the nuts and caps are glass filled polypropylene. All seals are self-lubricating EPDM to help prevent valve seizing after long periods of non-use. Internal o-rings can easily be replaced if service is required.

The bypass consists of two interchangeable plug valves that are operated independently by red arrow shaped handles. The handles identify the flow direction of the water. The plug valves enable the bypass valve to operate in four positions.

- 1. Normal Operation Position:** The inlet and outlet handles point in the direction of flow indicated by the engraved arrows on the control valve. Water flows through the control valve during normal operation and this position also allows the control valve to isolate the media bed during the regeneration cycle. (See Figure 1)
- 2. Bypass Position:** The inlet and outlet handles point to the center of the bypass, the control valve is isolated from the water pressure contained in the plumbing system. Untreated water is supplied to the plumbing system. (See Figure 2)
- 3. Diagnostic Position:** The inlet handle points in the direction of flow and the outlet handle points to the center of bypass valve, system water pressure is allowed to the control valve and the plumbing system while not allowing water to exit from the control valve to the plumbing. (See Figure 3)
- 4. Shut Off Position:** The inlet handle points to the center of the bypass valve and the outlet handle points in the direction of flow, the water is shut off to the plumbing system. If water is available on the outlet side of the softener it is an indication of water bypass around the system (i.e. a plumbing connection somewhere in the building bypasses the system). (See Figure 4)

BYPASS VALVE OPERATION

Figure 1

NORMAL OPERATION

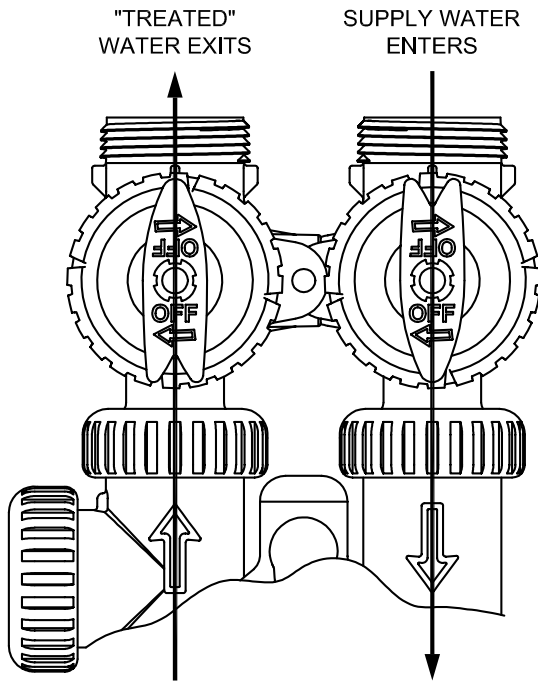

Figure 2

BYPASS OPERATION

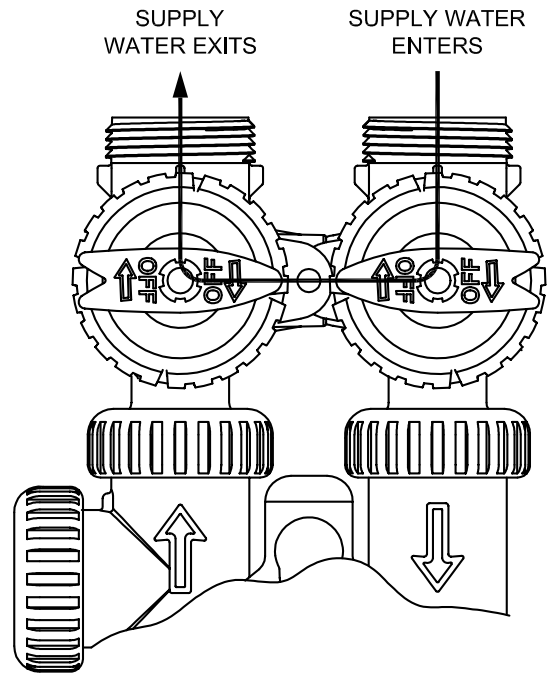

Figure 3

DIAGNOSTIC MODE

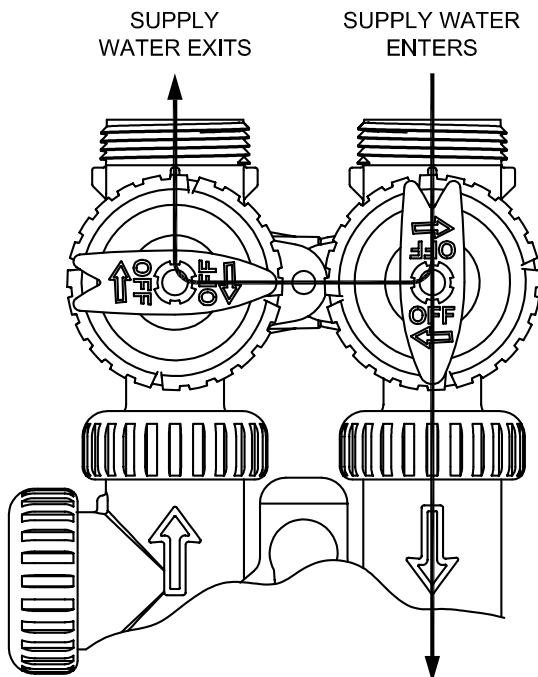
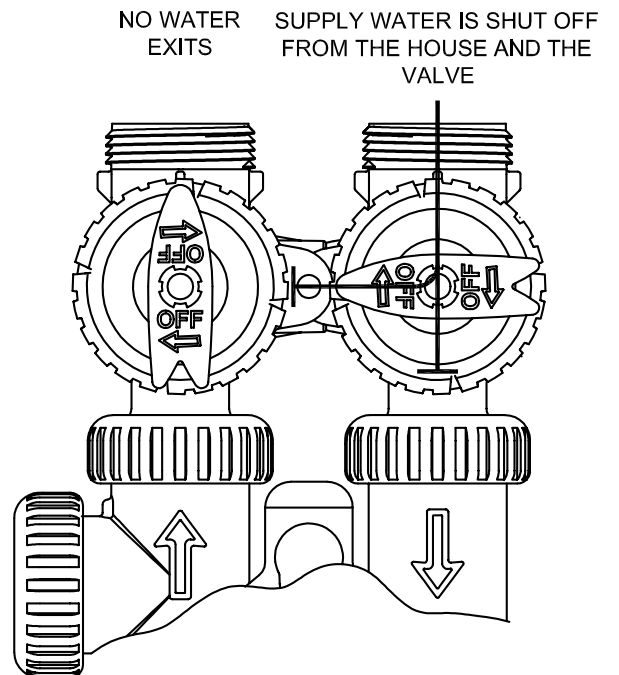

Figure 4

SHUT OFF MODE



OEM General Instructions

The control valve offers multiple procedures that allow the valve to be modified to suit the needs of the installation. These procedures are:

- OEM System Setup
- Installer Displays & Settings (either 1-99 Days Between Regeneration option or 7-Day option)
- User Displays

These procedures can be accessed in any order. Details on each of the procedures are provided below and on the following pages.

When in operation, normal user displays show the time of day or days remaining before regeneration. When stepping through a procedure if no buttons are pressed within five minutes the display returns to a normal user display. Any changes made prior to the five minute time out are incorporated.

To quickly exit Installer Displays & Settings or OEM Setup simultaneously press SET HOUR + DOWN. Any changes made prior to the exit are incorporated.

To reinitialize the control valve check to make sure the valve is in the User Display. Then simultaneously press SET HOUR + DOWN or unplug power source plug (black wire) on the circuit board, and plug back in.

STEP 1SS

OEM System Setup

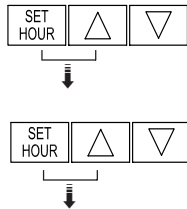

STEP 1SS – From normal mode, press SET HOUR + UP buttons simultaneously for 3 seconds and release. Then press SET HOUR + UP buttons simultaneously for 3 seconds and release.

STEP 2SS

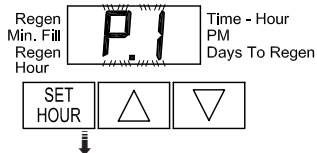

STEP 2SS – Choose the desired program by pressing the UP or DOWN buttons. Press SET HOUR button to go to Step 3SS.

Regeneration Cycles and Times for Different Programs

Program	All Times in Minutes				
	C1 1 st Backwash	C2 Regenerate	C3 2 nd Backwash	C4 Rinse	C5 Fill
P0	3	50	3	3	1-99
P1	8	50	8	4	1-99
P2	8	70	10	6	1-99
P3	12	70	12	8	1-99
P4	10	50	Skipped	8	1-99
P5	4	50	Skipped	4	1-99
P6	12	6	Skipped	12	1-99
P7	6	Skipped	Skipped	4	Skipped
P8	10	Skipped	Skipped	6	Skipped
P9	14	Skipped	Skipped	8	Skipped

Note: During regeneration the display will show C1, C2, etc. If the cycle is skipped, that cycle number will not be displayed.

STEP 3SS

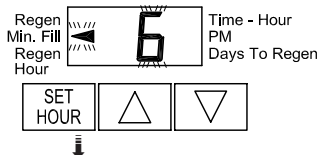

STEP 3SS – If program P0 through P6 was selected, enter in the minutes of fill using the UP or DOWN buttons. The allowable values vary from a low of 1 to a high of 99. If program P7, P8 or P9 was selected, dashes will appear for minutes of fill. Press SET HOUR button to go to Step 4SS. Note: For each minute of fill 0.5 gallons of water is added to the solution tank. With salt (sodium chloride) this equates to approximately 1 1/2 pounds of salt per minute of fill.

STEP 4SS

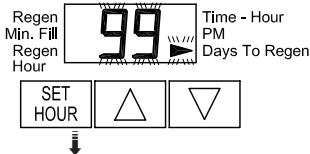

or

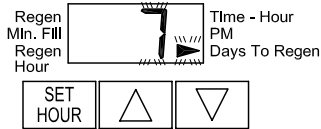

STEP 4SS — Use UP or DOWN buttons to switch between:

- 1-99 Days Between Regen; or
- 7-Day.

Press SET HOUR button to go to Step 5SS.

STEP 5SS

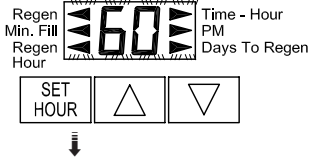

or

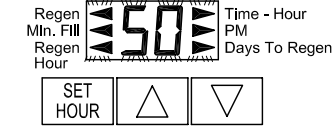

STEP 5SS — Use UP or DOWN buttons to switch between 60 Hz or 50 Hz option. Supply your own transformer if using 50 Hz option. Press SET HOUR button to go to Step 6SS.

STEP 6SS

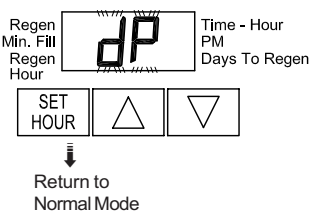

or

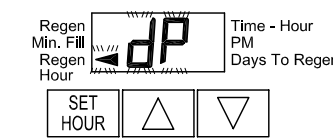

STEP 6SS — If a differential pressure switch is installed and actuated:

- a regeneration will occur immediately if no arrow points at Regen Hour; or
- a regeneration will occur at the delayed regeneration hour if an arrow points at Regen Hour.

Use UP or DOWN buttons to switch between the two choices. If a differential switch is not installed the settings in this display are ignored. Press SET HOUR to exit OEM system setup.



NOTE: A regeneration will be initiated or scheduled after the control has received a signal for five minutes.

A. Differential pressure switch connection

B. Motor wire connection

C. Transformer wire connection

STEP 11D

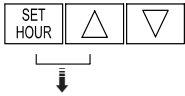

STEP 21D

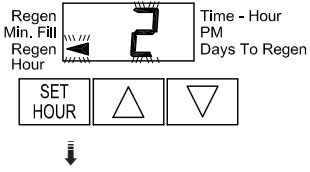

STEP 31D

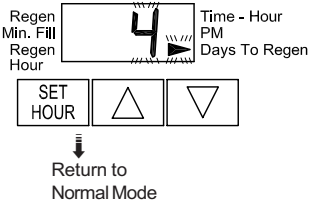

STEP 117

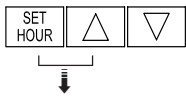

STEP 217

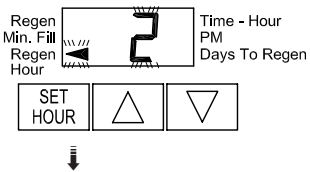

STEP 317

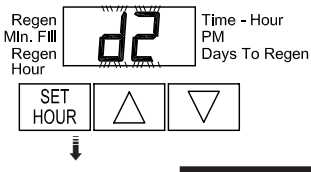

STEP 417

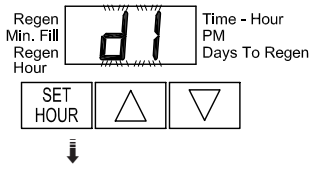

STEP 517

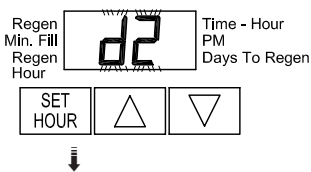

Installer Displays & Settings (1-99 Days Between Regeneration option)

STEP 11D – From normal mode, press SET HOUR + UP buttons simultaneously for 3 seconds and release.

STEP 21D – Regeneration Time: Set the clock to the hour the regeneration should occur by using the UP or DOWN buttons. An arrow points to PM after 12. Press SET HOUR to go to STEP 31D.

STEP 31D – Days To Regen: Set the number of days between regenerations. The allowable range is 1 to 99. Press SET HOUR to exit Installer Displays & Settings.

Installer Displays & Settings (7 day option)

STEP 117 – From normal mode, press SET HOUR + UP buttons simultaneously for 3 seconds and release.

STEP 217 – Regeneration Time: Set the clock to the hour the regeneration should occur by using the UP or DOWN buttons. An arrow points to PM after 12. Press SET HOUR to go to STEP 317.

STEP 317 – Current Day of Week: Set the current day of the week by using the UP or DOWN buttons (See chart at right for date codes). Press SET HOUR to go to STEP 417.

STEP 417 – Sunday Regeneration: To regenerate on Sunday use the UP or DOWN button until the arrow points to Regen. If the arrow does not point to Regen a regeneration will not occur on Sunday. Press SET HOUR to go to STEP 517.

STEP 517 – Monday Regeneration: To regenerate on Monday use the UP or DOWN button until the arrow points to Regen. If the arrow does not point to Regen a regeneration will not occur on Monday. Press SET HOUR to go to STEP 617.

Display	Day of Week
d1	Sunday
d2	Monday
d3	Tuesday
d4	Wednesday
d5	Thursday
d6	Friday
d7	Saturday

STEP 6I7

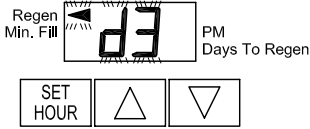

STEP 7I7

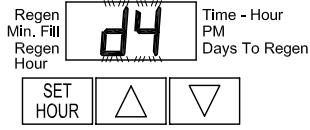

STEP 8I7

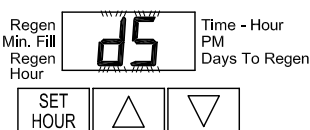

STEP 9I7

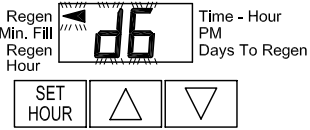

STEP 10I7

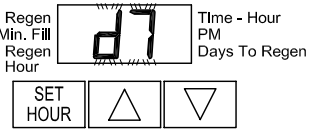

Return to Normal Mode

STEP 6I7 – Tuesday Regeneration: To regenerate on Tuesday use the UP or DOWN button until the arrow points to Regen. If the arrow does not point to Regen a regeneration will not occur on Tuesday. Press SET HOUR to go to STEP 7I7.

STEP 7I7 – Wednesday Regeneration: To regenerate on Wednesday use the UP or DOWN button until the arrow points to Regen. If the arrow does not point to Regen a regeneration will not occur on Wednesday. Press SET HOUR to go to STEP 8I7.

STEP 8I7 – Thursday Regeneration: To regenerate on Thursday use the UP or DOWN button until the arrow points to Regen. If the arrow does not point to Regen a regeneration will not occur on Thursday. Press SET HOUR to go to STEP 9I7.

STEP 9I7 – Friday Regeneration: To regenerate on Friday use the UP or DOWN button until the arrow points to Regen. If the arrow does not point to Regen a regeneration will not occur on Friday. Press SET HOUR to go to STEP 10I7.

STEP 10I7 – Saturday Regeneration: To regenerate on Saturday use the UP or DOWN button until the arrow points to Regen. If the arrow does not point to Regen a regeneration will not occur on Saturday. Press SET HOUR to exit Installer Displays & Settings.

NOTE: If all arrows are turned off in d1-d7, Days to Regen in the User Displays will always read 7 and a regeneration will never occur.

User Displays

General Operation

When the system is operating one of two displays will be shown. Pressing UP or DOWN button will alternate between the displays. One of the displays is always the current time of day (to the nearest hour). The second display is the days remaining until the next regeneration. If the days remaining is equal to one, a regeneration will occur at the next preset regeneration time. The user can scroll between displays as desired.

If the system has called for a regeneration that will occur at the preset time of regeneration, the arrow will point to Regen.

Regeneration Mode

Typically a system is set to regenerate at a time of low water usage. An example of a time with low water usage is when a household is asleep. If there is a demand for water when the system is regenerating, untreated water will be used.

When the system begins to regenerate, the display will change to indicate the cycle of the regeneration process (see Table 3) that is occurring and an arrow will also point to Regen. The system will run through the steps automatically and will reset itself to provide treated water when the regeneration is completed.

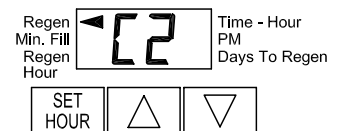
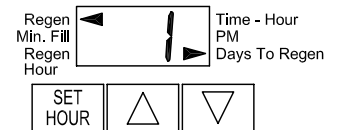
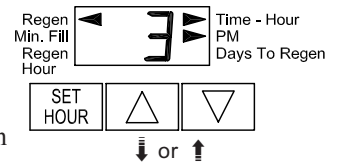

Manual Regeneration

Sometimes there is a need to regenerate the system, sooner than when the system calls for it, usually referred to as a manual regeneration. There may be a period of heavy water usage because of guests or a heavy laundry day.

To initiate a manual regeneration at the preset delayed regeneration time, simultaneously press UP + DOWN buttons together and release. The arrow will point to the word Regen if a regeneration is expected “tonight.” To cancel the regeneration simultaneously press UP + DOWN buttons and release.

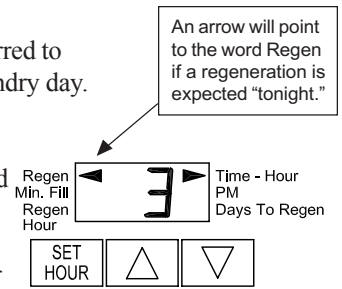

To initiate a manual regeneration immediately, simultaneously press UP + DOWN buttons together for three seconds. The system will begin to regenerate immediately. The request cannot be cancelled.

Note: For softeners, if brine tank does not contain salt, fill with salt and wait at least two hours before regenerating.

STEP 1U

Set Time of Day



STEP 1U – Press SET HOUR

STEP 2U

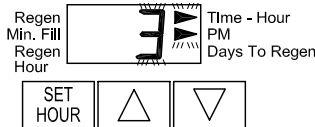

STEP 2U – Current time: Set the clock to the closest hour by using the UP and DOWN button. An arrow points to PM after 12. After a power outage, the time of day will need to be reset. Press SET HOUR to exit.

Power Loss

If the power goes out current time of day will need to be reset. If the power goes out while the system is regenerating, the cycle picks up where it was interrupted when the power returns. Note: The display will flash if a power outage has occurred.

Error Message

If “E1,” “E2” or “E3” appears on the display contact the OEM for help. This indicates that the valve did not function properly.

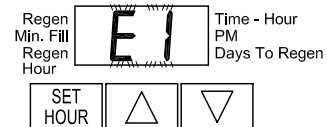

Installation

Refill Flow Control Assembly or Refill Port Plug

Control valves that are setup for backwash only come equipped with a refill port plug. The refill port plug has no regenerant line connection.

Control valves that use a regenerant, come equipped with a 3/8” refill flow control assembly. To switch to the 1/2” refill flow control assembly, remove the refill flow control and retainer (from the 3/8” refill elbow) by twisting and pulling out. Insert the refill flow control and retainer into the 1/2” refill elbow.

To complete the regenerant line connection, orientate the outlet in the desired direction and push the plastic insert into the polytube. Push the polytube into the nut. Do not use pipe dope or other sealants on threads. The threads for the compression nut do not need Teflon tape. Tighten the nut securely to create a pressure tight connection. A pliers or crescent wrench may be used to tighten or unscrew the nut. The nut, gripper and retainer sleeve is a 3 piece assembly that can come apart if removed from the elbow body. Parts must be reassembled exactly as shown in refill flow control assembly drawing to function properly. If the nut is completely removed from the body, slip the nut, plastic gripper and retainer sleeve on to the tube then tighten on to the fitting.

Drain Line Flow Control and Fitting Assembly

To determine which drain line flow control to use, obtain media bed expansion tables from the media manufacturer, choose a water temperature and look up the desired backwash rate per square foot of bed area. Then calculate the backwash rate using the desired tank diameter. Using **Table 5** pick the drain line flow control that has the backwash flow rate closest to the calculated backwash rate. If a manufacturer chooses to use an external drain line flow control, use a drain elbow fitting that does not contain a hole.

If the drain line is a 5/8” flexible polytube, slide the nut onto the polytube, then place the polytube insert into the end of the polytube

and tighten the nut on to the $\frac{3}{4}$ " drain line fitting. The nut is only designed for use with flexible polytube. Use other nuts if attaching different materials.

To access the drain line flow control remove the locking clip by pulling it straight out. Pull fitting out and replace the locking clip so that it is not misplaced. The drain line fitting is pressed in and has an o-ring seal.

In the $\frac{3}{4}$ " elbow, the white flow control retainer is pressed in and has an o-ring seal. The retainer can be removed by rotating and pulling. The flow control can be removed by prying upward with a small blade flat screwdriver in one of the slots on the side. The drain line flow control and retainer can be chemically cleaned in dilute sodium bisulfite or vinegar or replaced. Do not use a wire brush to clean the flow control or the washer. The washers are identified with three numbers, which correspond to the flow rate. When reinstalling make sure the identifying number and the rounded inside diameter on the washer is visible when seated in the retainer. The white flow control washer retainer can also be removed and cleaned. Push retainer in firmly when reinstalling.

In the 1" straight fitting, the retainer is the fitting. Unscrew the nut to access the flow control. The drain line flow control and the fitting can be chemically cleaned or replaced. Do not use a wire brush to clean the flow control or the fitting.

Do not use Vaseline, oils, or other unacceptable lubricants on o-rings. A silicon lubricant may be used on the black o-ring. Use a pliers or crescent wrench to tighten or unscrew the nut. Do not use a pipe wrench to tighten or loosen nut. Do not use pipe dope or other sealants on threads. Use Teflon tape on the threads of the drain line control fitting when installing $\frac{3}{4}$ " NPT or 1" straight fitting.

Installation Fitting Assemblies

The installation fittings connect to the control valve or the bypass valve using nuts that only require hand tightening. Hand tighten nut connections between control valve and installation fittings, control valve and bypass valve, and bypass valve and installation fittings allow for easy serviceability. Do not use a pipe wrench to tighten nuts on installation fittings. Hand tighten only.

Split ring retainer design holds the nut on and allows load to be spread over the entire nut surface area reducing the chance for leakage. The split ring design, incorporated into the installation fittings allows approximately 2 degrees off axis alignment to the plumbing system. The installation fittings are designed to accommodate minor plumbing misalignments but are not designed to support the weight of a system or the plumbing.

When assembling the installation fitting package, connect the fitting to the plumbing system first and then attach the nut, split ring and o-ring. Heat from soldering or solvent cements may damage the nut, split ring or o-ring. Solder joints should be cool and solvent cements should be set before installing the nut, split ring and o-ring. Avoid getting primer and solvent cement on any part of the o-rings, split rings, bypass valve or control valve. Solvent cements and primers should be used in accordance with the manufacturer's instructions.

Slip the nut onto the fitting first, then the split ring second and the o-ring last. Hand tighten the nut. If the fitting is leaking tightening the nut will not stop the leak. Remove the nut, remove the fitting, and check for damage or misalignment of the o-ring.

Do not use pipe dope or other sealant on threads. Teflon tape must be used on the threads of the 1" NPT elbow and the $\frac{1}{4}$ " NPT connection and on the threads for the drain line connection. Teflon tape is not necessary on the nut connection or caps because of o-ring seals.

Do not use Vaseline, oils, or other unacceptable lubricants on o-rings. A silicon lubricant may be used on black o-rings.

Bypass Valve

The bypass valve easily connects to the control valve body using nuts that only require hand tightening. Hand tighten nut connections between control valve and fittings, control valve and bypass valve, and bypass valve and installation fittings allow for easy serviceability. The split ring retainer design holds the nut on and allows load to be spread over the entire nut surface area reducing the chance for leakage. The split ring design, incorporated into the bypass, allows approximately 2 degrees off axis alignment to the plumbing system. The bypass is designed to accommodate minor plumbing misalignments but is not designed to support the weight of a system or the plumbing.

Avoid getting primer and solvent cements on any part of the o-rings or split rings, bypass valve or control valve. Do not use pipe dope or other sealant on threads. Teflon tape is not necessary on the caps because of o-ring seals.

Do not use Vaseline, oils, or other unacceptable lubricants on o-rings. A silicon lubricant may be used on black o-rings.

Drawings and Part Numbers

Front Cover and Drive Assembly

Drawing No.	Order No.	Description	Quantity
1	V3175TC-01	WS1TC Front Cover ASY	1
2	V3107-01	WS1 Motor	1
3	V3106-01	WS1 Drive Bracket&Spring Clip	1
4	V3108TC	WS1TC PC Board	1
5	V3110	WS1 Drive Gear 12x36	3
6	V3109	WS1 Drive Gear Cover	1
	V3002TC	WS1TC Drive ASY	*
Not Shown	V3186	WS1 Transformer 110V-12V	1

* Drawing number parts 2 through 6 may be purchased as a complete assembly, part V3002TC.

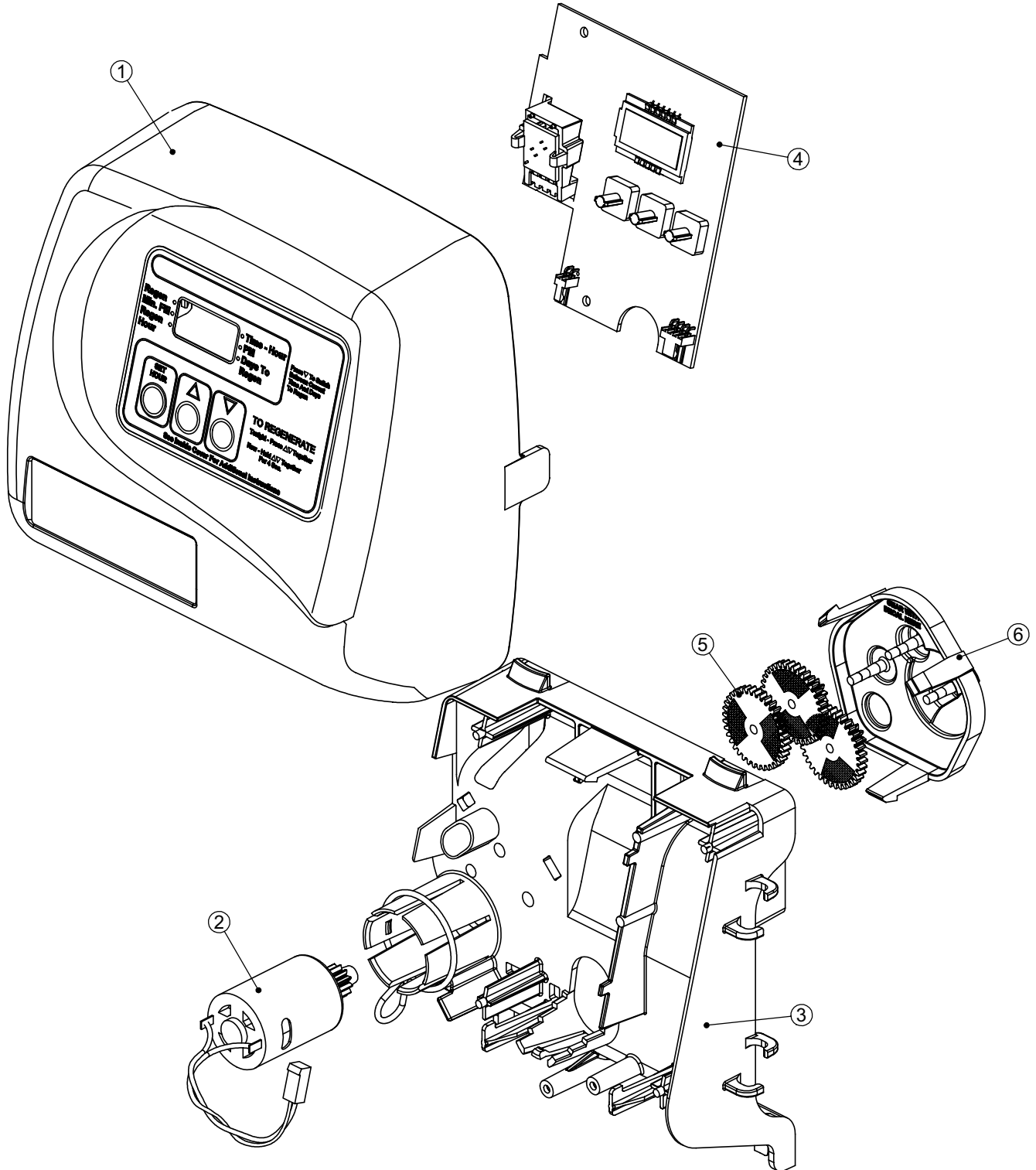

Drive Cap Assembly, Downflow Piston, Upflow Piston, Regenerant Piston and Spacer Stack Assembly

Drawing No.	Order No.	Description	Quantity
1	V3005	WS1 Spacer Stack Assembly	1
2	V3004	Drive Cap ASY	1
3	V3135	O-ring 228	1
4	V3011	WS1 Piston Downflow ASY	1
5	V3174	WS1 Regenerant Piston	1
6	V3180	O-ring 337	1

Note: The regenerant piston is not used in backwash only applications.

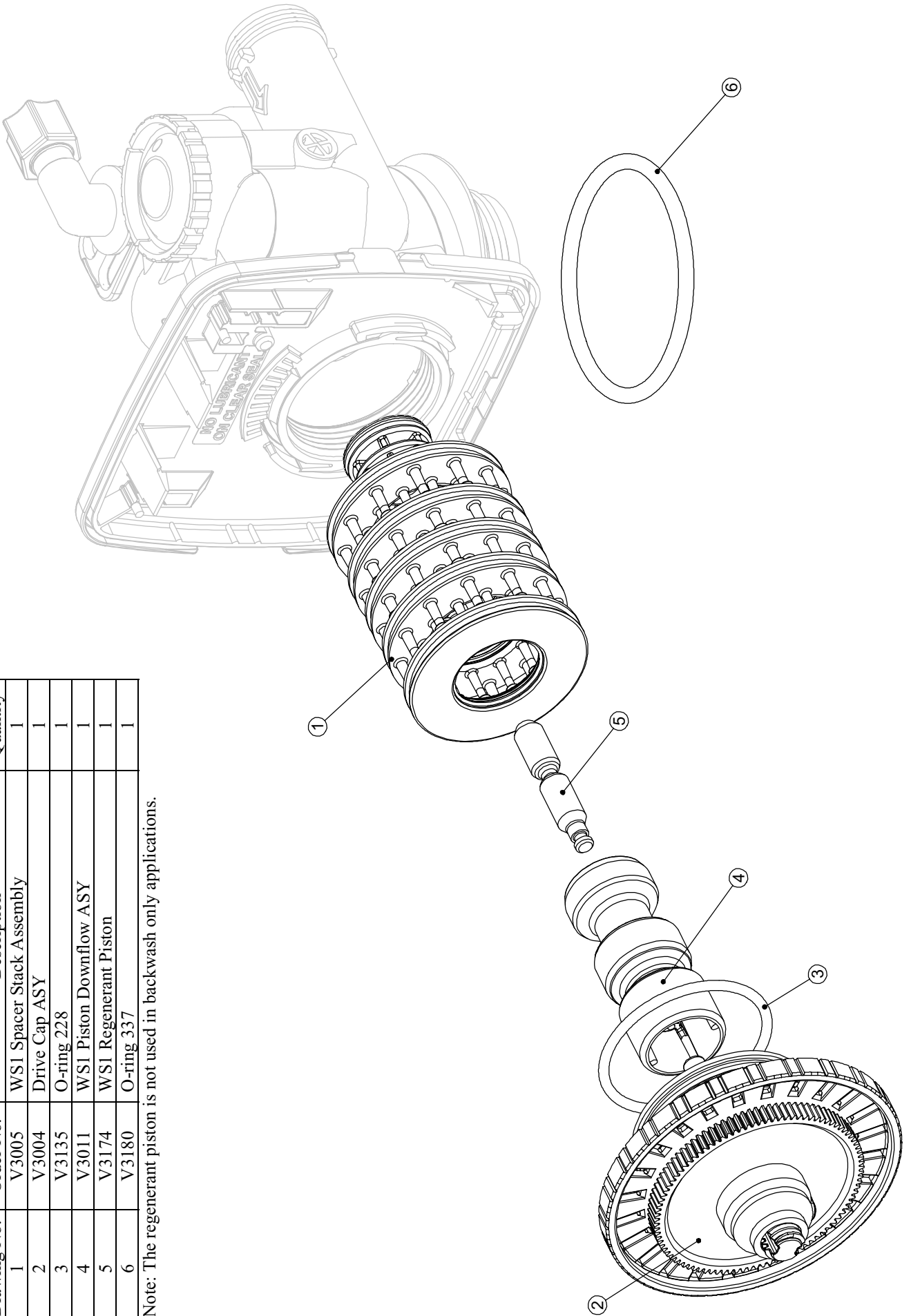

Injector Cap, Injector Screen, Injector, Plug and O-Ring

Drawing No.	Order No.	Description	Quantity
1	V3176	Injector Cap	1
2	V3152	O-ring 135	1
3	V3177	Injector Screen	1
4	V3010-1Z	WS1 Injector ASY Z Plug	1
5	V3010-1A	WS1 INJECTOR ASY A BLACK	1
	V3010-1B	WS1 INJECTOR ASY B BROWN	
	V3010-1C	WS1 INJECTOR ASY C VIOLET	
	V3010-1D	WS1 INJECTOR ASY D RED	
	V3010-1E	WS1 INJECTOR ASY E WHITE	
	V3010-1F	WS1 INJECTOR ASY F BLUE	
	V3010-1G	WS1 INJECTOR ASY G YELLOW	
	V3010-1H	WS1 INJECTOR ASY H GREEN	
	V3010-1I	WS1 INJECTOR ASY I ORANGE	
	V3010-1J	WS1 INJECTOR ASY J LIGHT BLUE	
V3010-1K	WS1 INJECTOR ASY K LIGHT GREEN		
Not Shown	V3170	O-ring 011	*
Not Shown	V3171	O-ring 013	*

*The injector plug and the injector each contain one 011 (lower) and 013 (upper) o-ring.

Note: For downflow, injector is located in the down hole and injector plug in the up hole. For a filter that only backwashes, injector plugs are located in both holes, and regenerant piston must be removed.

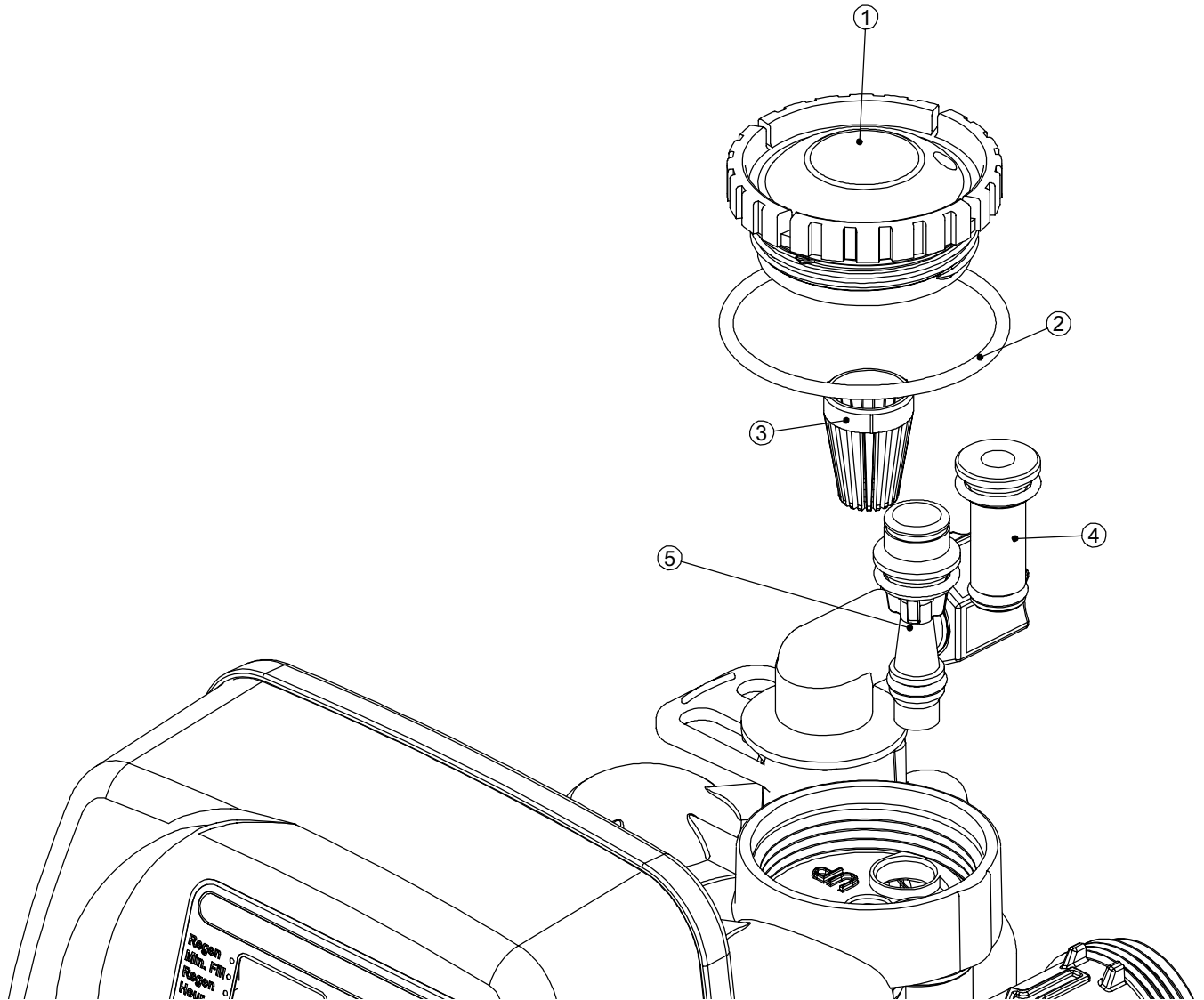

Refill and Refill Port Plug

Drawing No.	Order No.	Description	Quantity
1	V3195-01	WS1 Refill Port Plug ASY	This part is required for backwash only systems
2	H4615	Elbow Locking Clip	1
3	JCP-P-6	Polytube insert 3/8	1
4	JCPG-6PBLK	Nut 3/8	1
5	H4613	Elbow Cap 3/8	1
6	V3163	O-ring 019	1
7	V3165-01*	WS1 RFC Retainer ASY	1
8	V3182	WS1 RFC	1
Not Shown	H4650	Elbow 1/2" with nut and insert	Option

*Assembly includes WS1 RFC.

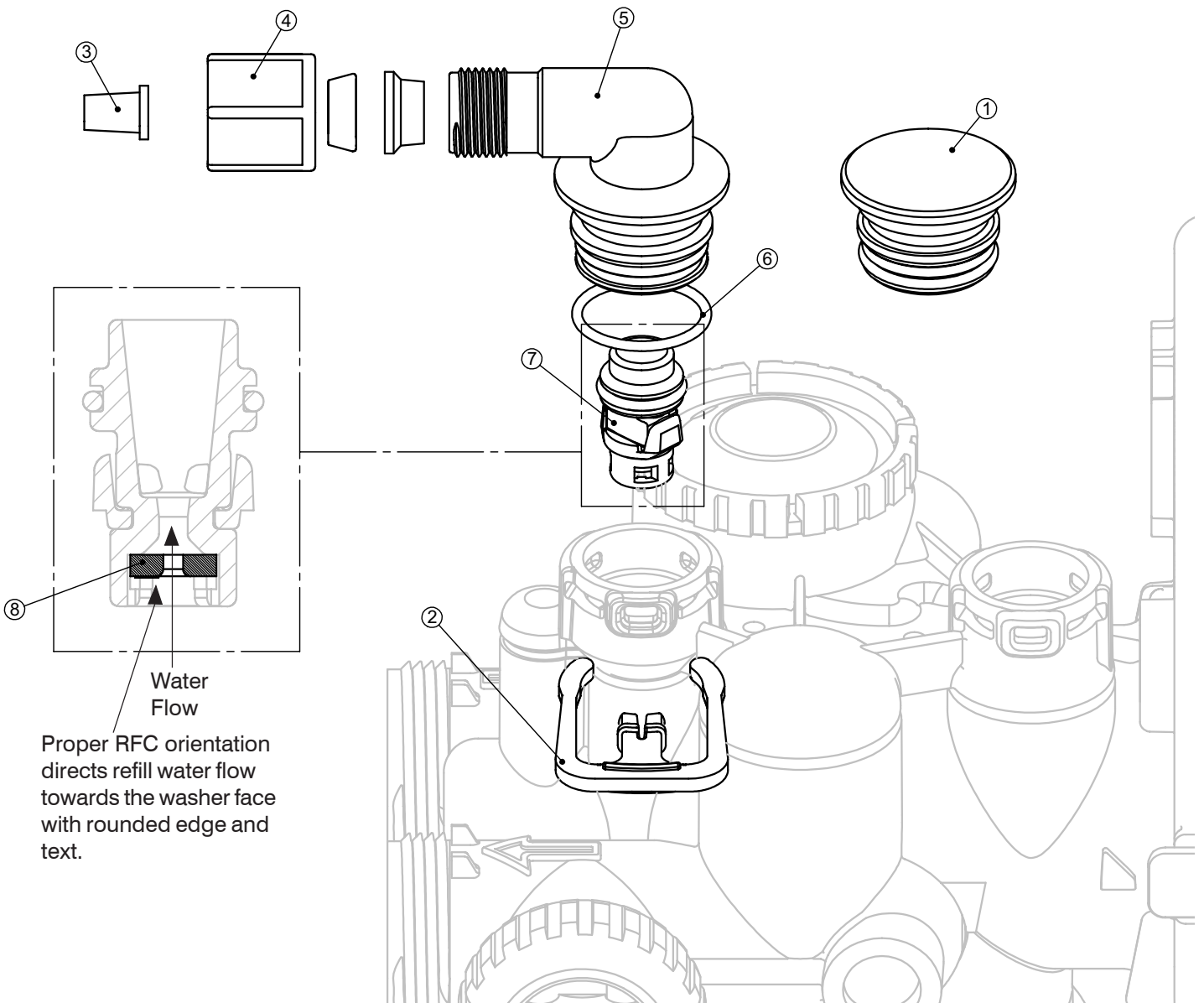

Drain Line – 3/4"

Drawing No.	Order No.	Description	Quantity
1	H4615	Elbow Locking Clip	1
2	PKP10TS8-BULK	Polytube insert 5/8	Option
3	V3192	WS1 Nut 3/4 Drain Elbow	Option
4	V3158-01	WS1 Drain Elbow 3/4 Male ASY	1
5	V3163	O-ring 019	1
6	V3159-01	WS1 DLFC Retainer ASY	1
7	V3162-007	WS1 DLFC 0.7 gpm for 3/4	One DLFC must be used if 3/4" fitting is used
	V3162-010	WS1 DLFC 1.0 gpm for 3/4	
	V3162-013	WS1 DLFC 1.3 gpm for 3/4	
	V3162-017	WS1 DLFC 1.7 gpm for 3/4	
	V3162-022	WS1 DLFC 2.2 gpm for 3/4	
	V3162-027	WS1 DLFC 2.7 gpm for 3/4	
	V3162-032	WS1 DLFC 3.2 f gpm or 3/4	
	V3162-042	WS1 DLFC 4.2 gpm for 3/4	
	V3162-053	WS1 DLFC 5.3 gpm for 3/4	
	V3162-065	WS1 DLFC 6.5 gpm for 3/4	
	V3162-075	WS1 DLFC 7.5 gpm for 3/4	
V3162-090	WS1 DLFC 9.0 gpm for 3/4		
V3162-100	WS1 DLFC 10.0 gpm for 3/4		

Valves are shipped without drain line flow control (DLFC) – install DLFC before using. Valves are shipped without 3/4" nut for drain elbow (polytube installation only) and 5/8" polytube insert (polytube installation only).

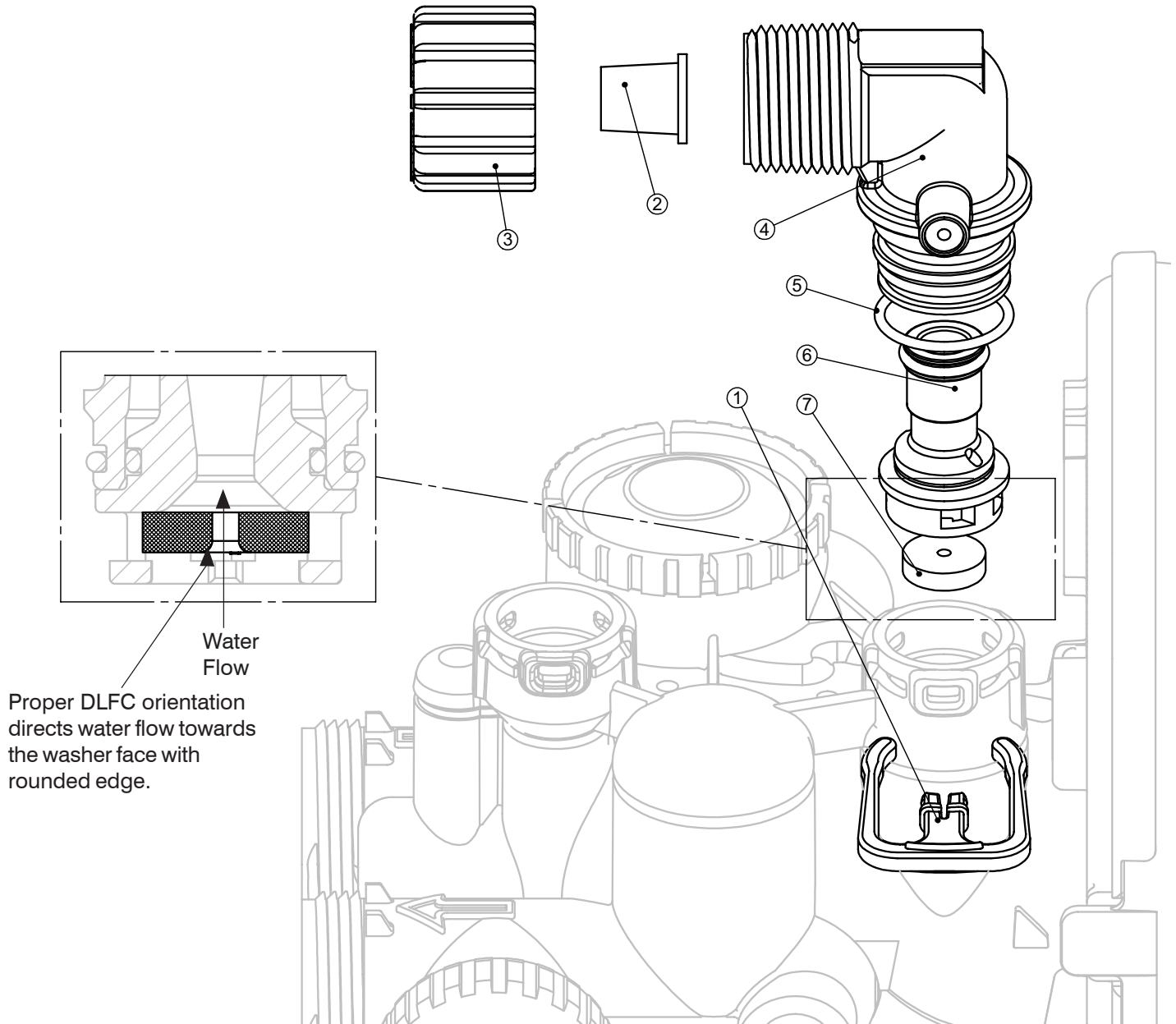

Drain Line – 1”

Drawing No.	Order No.	Description	Quantity
1	H4615	Elbow Locking Clip	1
2	V3008-02	WS1 Drain FTG 1 Straight	1
3*	V3166	WS1 Drain FTG Body 1	1
4*	V3167	WS1 Drain FTG Adapter 1	1
5*	V3163	O-ring 019	1
6*	V3150	WS1 Split Ring	1
7*	V3151	WS1 Nut 1" QC	1
8*	V3105	O-ring 215	1
9	V3190-090	WS1 DLFC 9.0 gpm for 1	One DLFC must be used if 1" fitting is used
	V3190-100	WS1 DLFC 10.0 gpm for 1	
	V3190-110	WS1 DLFC 11.0 gpm for 1	
	V3190-130	WS1 DLFC 13.0 gpm for 1	
	V3190-150	WS1 DLFC 15.0 gpm for 1	
	V3190-170	WS1 DLFC 17.0 gpm for 1	
	V3190-200	WS1 DLFC 20.0 gpm for 1	
	V3190-250	WS1 DLFC 25.0 gpm for 1	

* Can be ordered as a set order number V3008-02, description: WS1 Drain FTG 1 Straight.

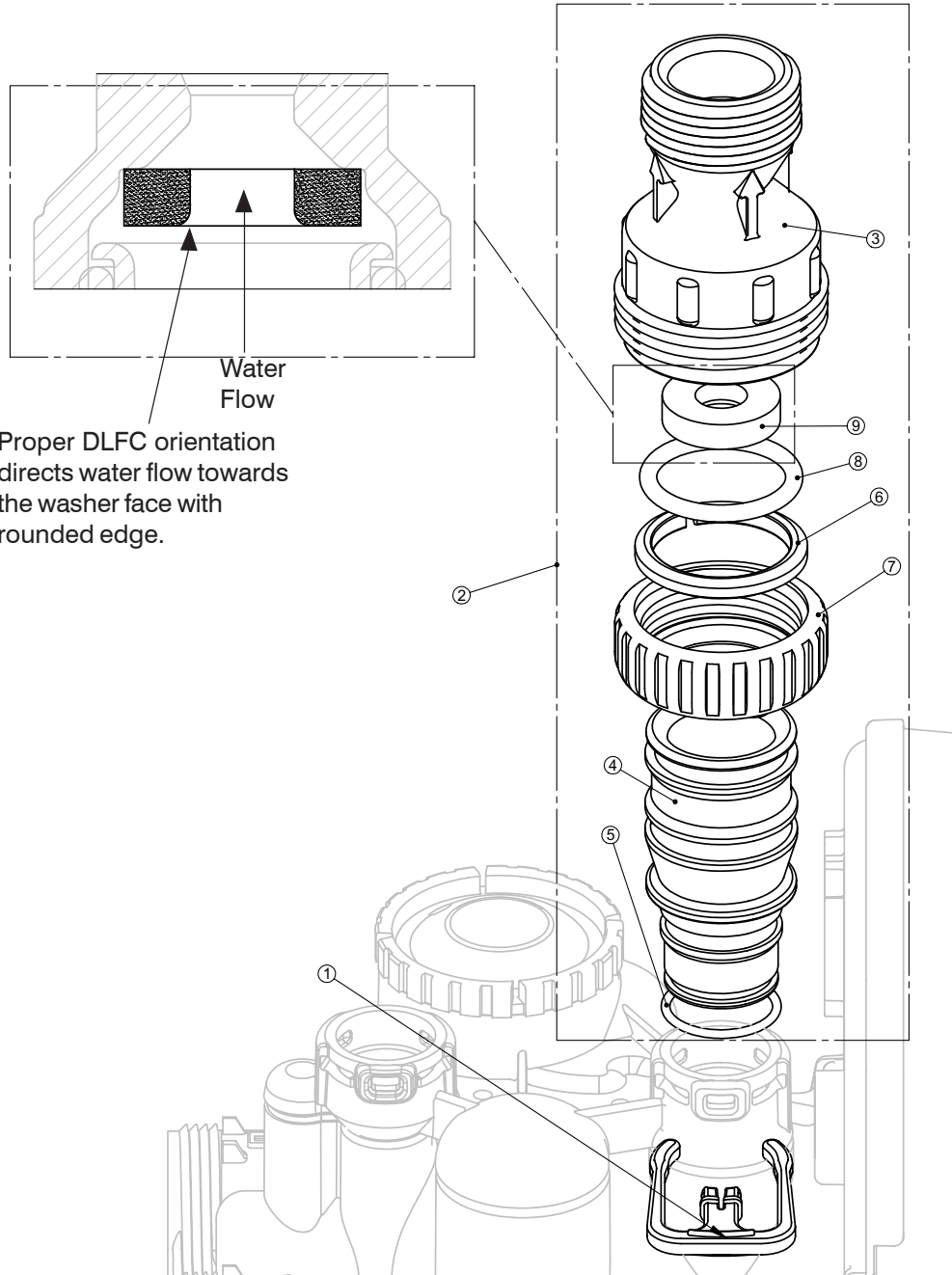

Meter Plug

Drawing No.	Order No.	Description	Quantity
1	V3151	WS1 Nut 1" QC	1
2	V3105	O-ring 215	1
3	V3003-01	WS1 Meter Plug ASY	1

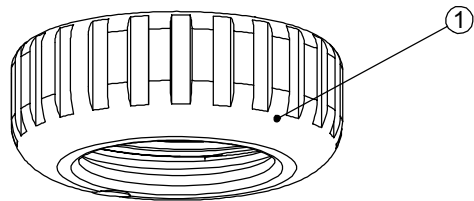
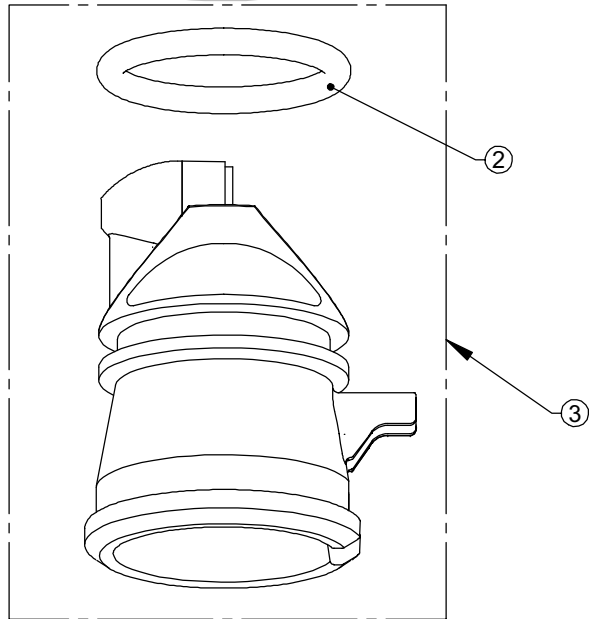
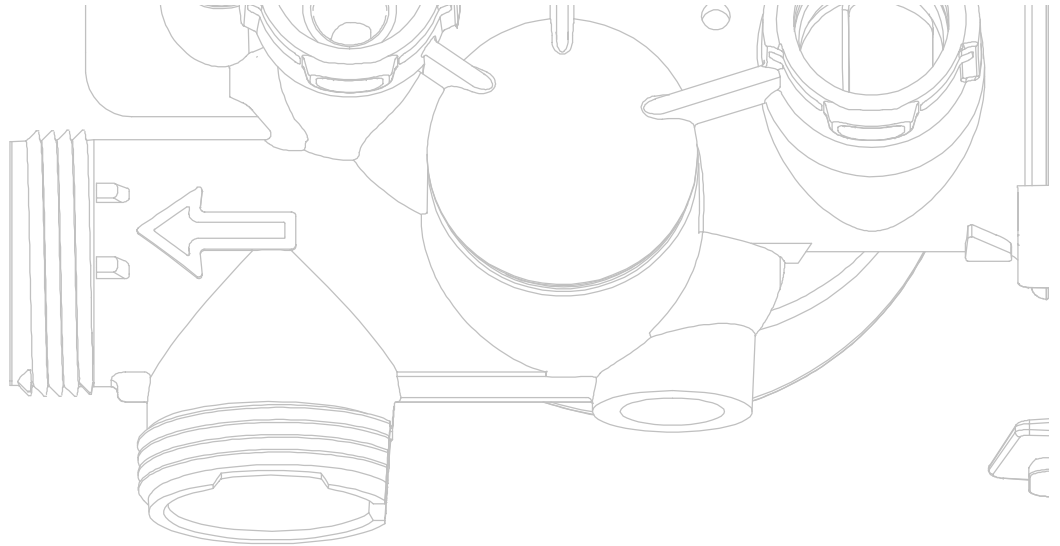

Installation Fitting Assemblies

Order No: **V3007**

Description: **WS1 Fitting 1" PVC Male NPT Elbow Assembly**

Drawing No	Order No.	Description	Quantity
1	V3151	WS1 Nut 1" Quick Connect	2
2	V3150	WS1 Split Ring	2
3	V3105	O-Ring 215	2
4	V3149	WS1 Fitting 1 PVC Male NPT Elbow	2

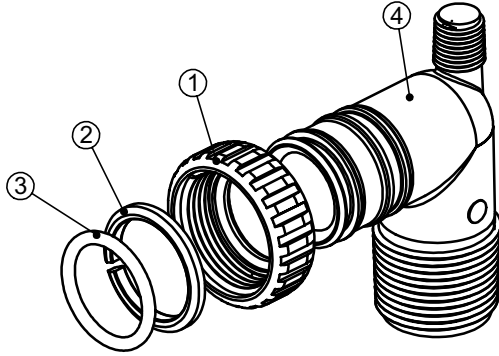

Order No: **V3007-01**

Description: **WS1 Fitting 3/4" & 1" PVC Solvent 90° ASY**

Drawing No.	Order No.	Description	Quantity
1	V3151	WS1 Nut 1" Quick Connect	2
2	V3150	WS1 Split Ring	2
3	V3105	O-Ring 215	2
4	V3189	WS1 Fitting 3/4" & 1" PVC Solvent 90°	2

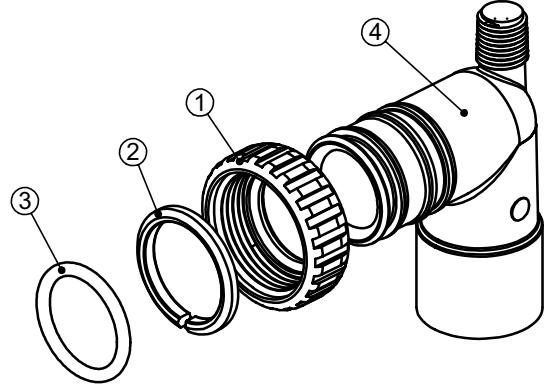

Order No: **V3007-02**

Description: **WS1 Fitting 1" Brass Sweat Assembly**

Drawing No.	Order No.	Description	Quantity
1	V3151	WS1 Nut 1" Quick Connect	2
2	V3150	WS1 Split Ring	2
3	V3105	O-Ring 215	2
4	V3188	WS1 Fitting 1 Brass Sweat	2

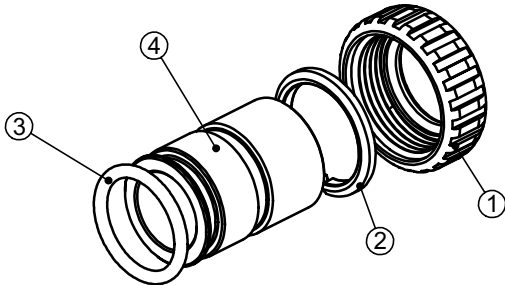

Order No: **V3007-03**

Description: **WS1 Fitting 3/4" Brass Sweat Assembly**

Drawing No.	Order No.	Description	Quantity
1	V3151	WS1 Nut 1" Quick Connect	2
2	V3150	WS1 Split Ring	2
3	V3105	O-Ring 215	2
4	V3188-01	WS1 Fitting 3/4" Brass Sweat	2

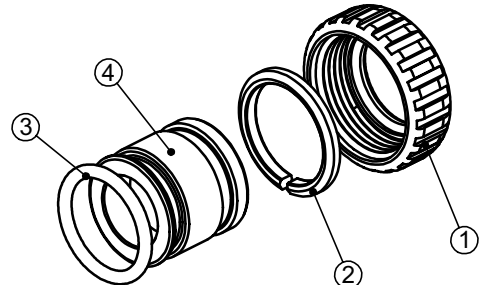

Bypass Valve

Drawing No.	Order No.	Description	Quantity
1	V3151	WS1 Nut 1" Quick Connect	2
2	V3150	WS1 Split Ring	2
3	V3105	O-Ring 215	2
4	V3145	WS1 Bypass 1" Rotor	2
5	V3146	WS1 Bypass Cap	2
6	V3147	WS1 Bypass Handle	2
7	V3148	WS1 Bypass Rotor Seal Retainer	2
8	V3152	O-ring 135	2
9	V3155	O-ring 112	2
10	V3156	O-ring 214	2

(Not Shown) Order No. V3191-01, Description: WS1 Bypass Vertical Adapter Assembly

Order No.	Description	Quantity
V3151	WS1 Nut 1" Quick Connect	2
V3150	WS1 Split Ring	2
V3105	O-Ring 215	2
V3191-01	WS1 Bypass Vertical Adapter Assembly	2

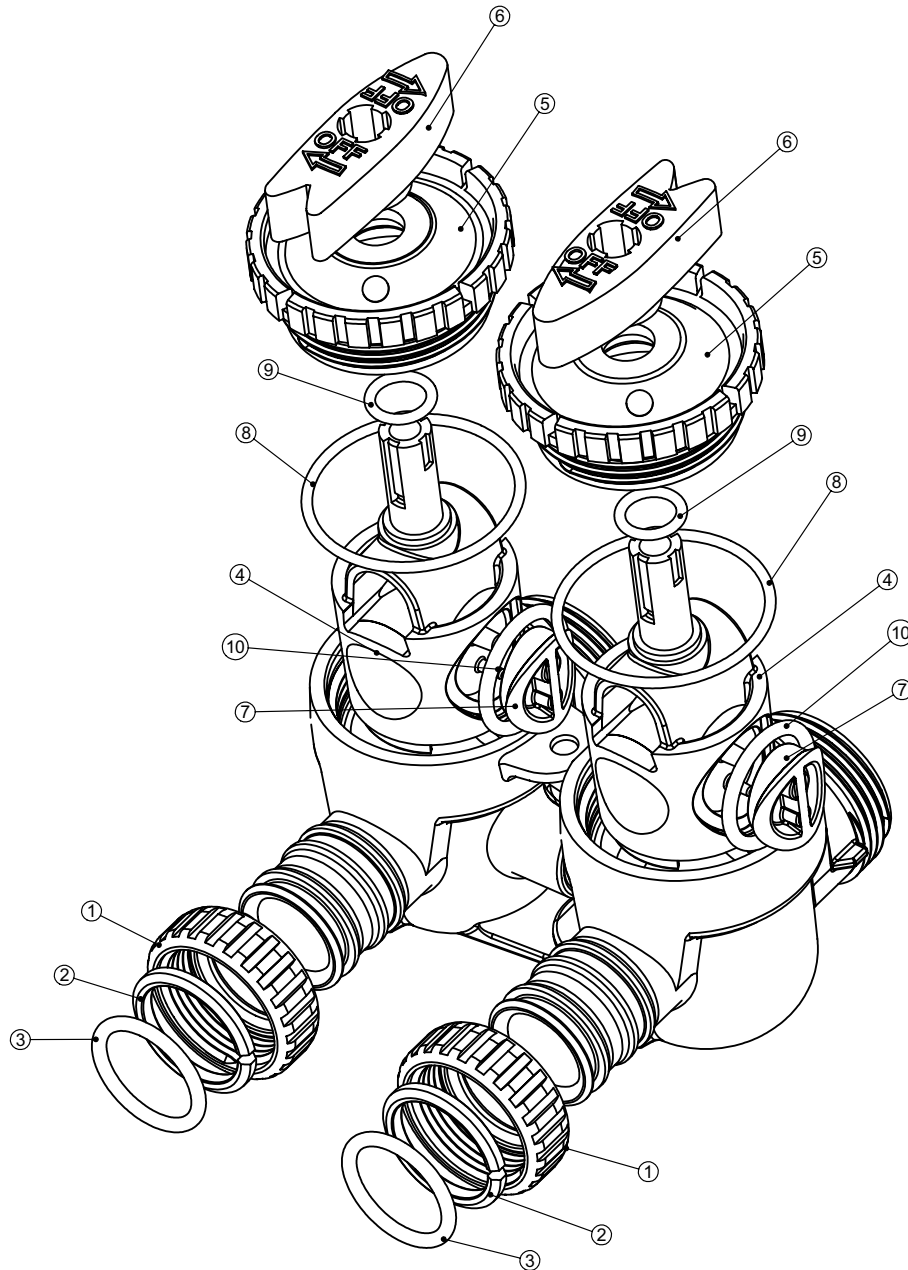

Flow Diagrams – Service and Backwash

flow diagram...service

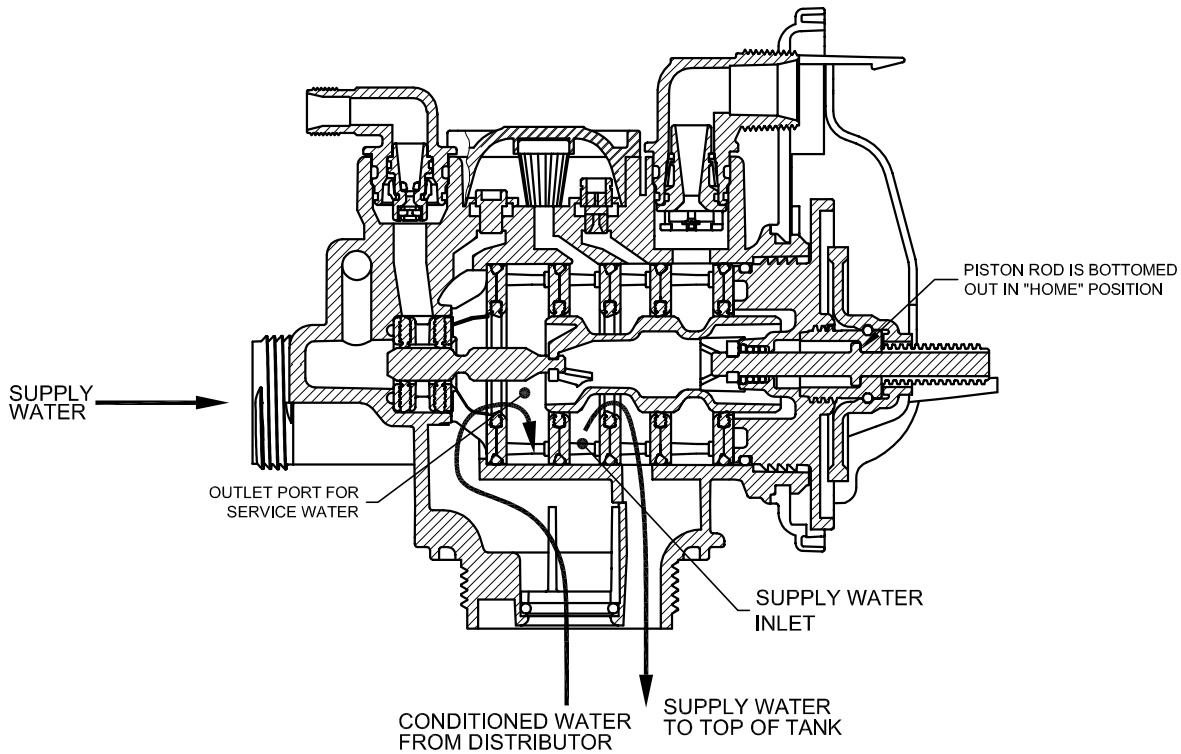

flow diagram...backwash

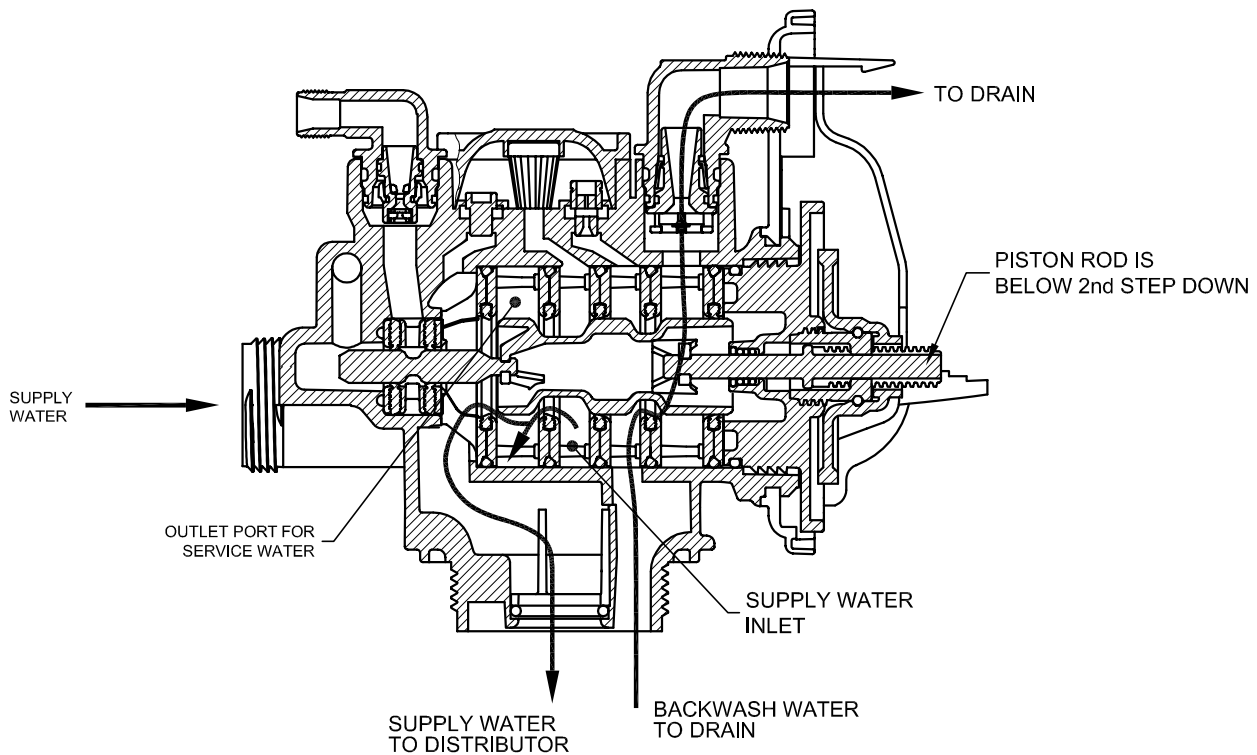

Flow Diagrams – Downflow Brine and Rinse

flow diagram...downflow brine

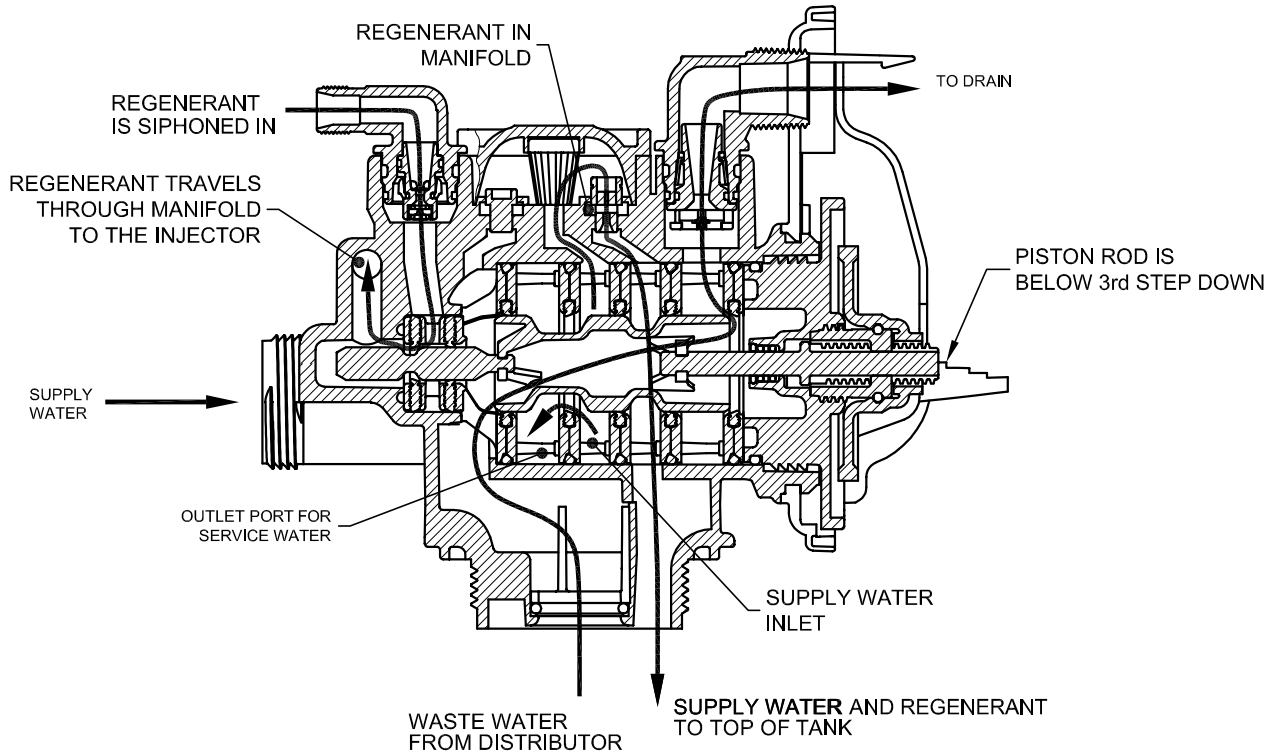

flow diagram...rinse

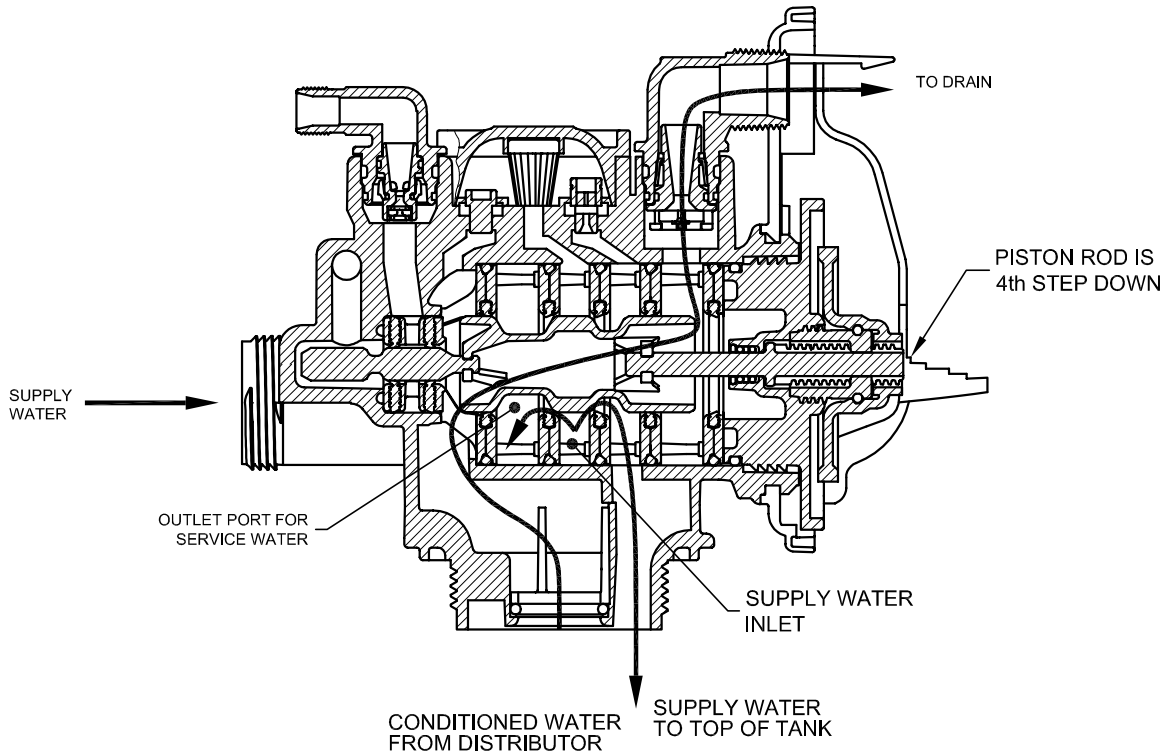

Flow Diagrams – Fill

flow diagram...fill

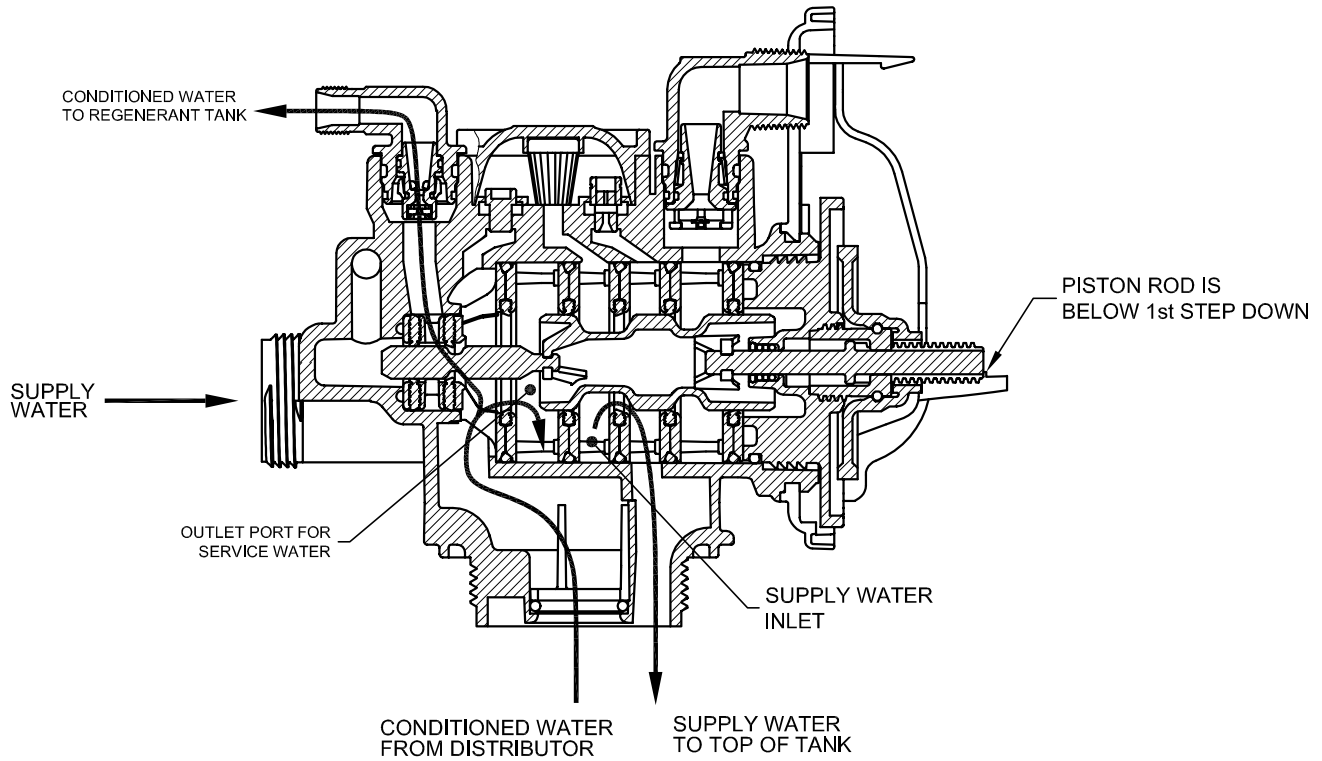

WS1 Wrench (Order No. V3193)

Although no tools are necessary to assemble or disassemble the valve, the WS1 wrench (shown in various positions on the valve) may be purchased to aid in assembly or disassembly.

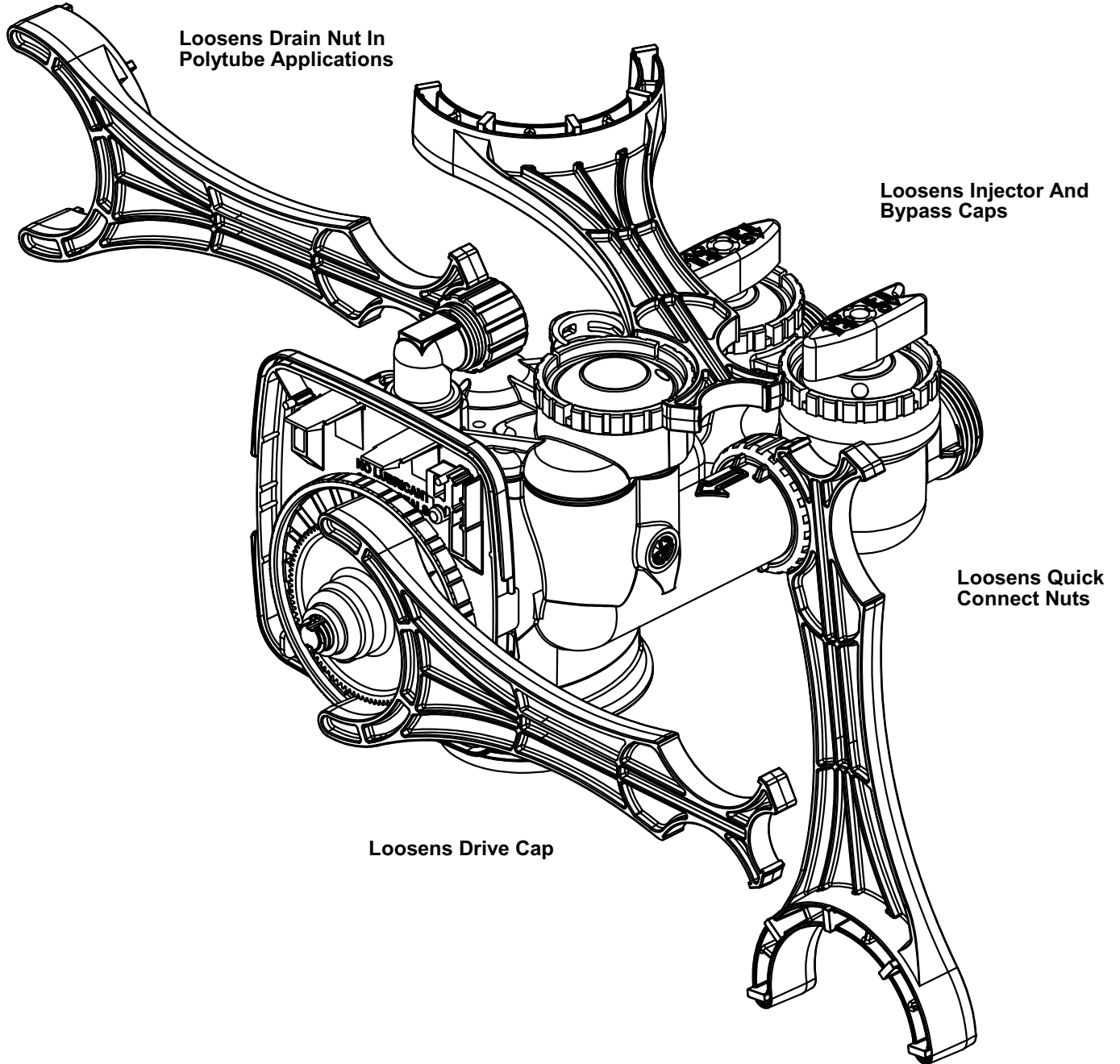

Service Instructions

Drive Assembly

Remove the valve cover to access the drive assembly.

Disconnect the power source plug (black wire) from the PC board prior to disconnecting the motor plug from the PC board. The motor plug connects to the two-pin jack on the left-hand side of the PC board. The power source plug connects to the four-pin jack.

The PC board can be removed separately from the drive bracket but it is not recommended. Do not attempt to remove the display panel from the PC board. Handle the board by the edges. To remove the PC board from the drive bracket, unplug the power and motor plugs from the PC board. Lift the middle latch along the top of the drive bracket while pulling outward on the top of the PC board. The drive bracket has one plastic pin that fits into the hole on the lower edge of the PC board. Once the PC board is tilted about 45° from the drive bracket it can be lifted off of the pin. To reinstall the PC board, position the lower edge of the PC board so that the hole in the PC board lines up with the plastic pin. Push the top of the PC board towards the valve. Align the upper hole on left-hand side of PC board with the pin and push in until the PC board snaps under the middle latch, weave the power wire into the holders and reconnect the motor and power plugs.

The drive bracket must be removed to access the drive cap assembly and pistons or the drive gear cover. It is not necessary to remove the PC board from the drive bracket to remove the drive bracket. To remove the drive bracket start by removing the plug for the power source. Unweave the wire from the side holders. Two tabs on the top of the drive back plate hold the drive bracket in place. Simultaneously lift the two tabs and gently ease the top of the drive bracket towards your body. The lower edge of the drive bracket has two notches that rest on the drive back plate. Lift up and outward on the drive bracket to disengage the notches.

To reassemble seat the bottom of the drive bracket so the notches are engaged at the bottom of the drive back plate. Push the top of the drive bracket towards the two latches. The drive bracket may have to be lifted slightly to let the threaded piston rod pass through the hole in the drive bracket. Maintain a slight engaging force on top of the drive bracket while deflecting the bracket slightly to the left by pressing on the side of the upper right corner. This helps the drive gears mesh with the drive cap assembly. The drive bracket is properly seated when it snaps under the latches on the drive back plate. If resistance is felt before latching, then notches are not fully engaged, the piston rod is not in hole, the power wire is jammed between the drive bracket and drive back plate, or the gear is not engaging the drive cap assembly.

To inspect drive gears, the drive gear cover needs to be removed. The drive gear cover is held in place on the drive bracket by three clips. The largest of the three clips is always orientated to the bottom of the drive bracket. Before trying to remove the drive gear cover, the drive bracket must be removed from the drive back plate. The drive gear cover can be removed from the drive bracket without removing the motor or the PC board. Simultaneously, push in and down on the large clip at the bottom and the clip on the left-hand side of the drive bracket behind the PC board. Keep your other fingers behind the drive gear cover so the drive gears do not drop on the ground.

Replace broken or damaged drive gears. Do not lubricate any of the gears. Avoid getting any foreign matter on the reflective coating because dirt or oils may interfere with pulse counting.

The drive gear cover only fits on one way, with the large clip orientated towards the bottom. If all three clips are outside of the gear shroud on the drive bracket the drive gear cover slips easily into place.

The drive bracket does not need to be removed from the drive plate if the motor needs to be removed. To remove the motor, disconnect the power and motor plugs from the jacks on the PC board. Move the spring clip loop to the right and hold. Rotate the motor at least a ¼ turn in either direction before gently pulling on the wire connectors to remove the motor. Pulling directly on the wires without rotating the motor may break the wires off the motor.

Replace the motor if necessary. Do not lubricate the motor or the gears. When reinstalling the motor gently turn the motor while inserting so that the gear on the motor meshes with the gears under the drive gear cover and the small plastic bulge engages one of the slots on the motor housing. Reconnect the motor plug to the two pronged jack on the lower left hand side of the PC board. If motor will not easily engage with drive gear when reinstalling, lift and slightly rotate motor before reinserting.

Replace the valve cover. After completing any valve maintenance, press and hold SET HOUR and DOWN buttons for 3 seconds or unplug power source jack (black wire) from the circuit board and plug back in. This resets the electronics and establishes the service piston position.

Drive Cap Assembly, Main Piston and Regenerant Piston

The drive assembly must be removed to access the drive cap assembly. The drive cap assembly must be removed to access the piston(s). The drive cap assembly is threaded into the control valve body and seals with an o-ring. To remove the drive cap assembly use the special plastic wrench or insert a 1/4" to 1/2" flat bladed screwdriver into one of the slots around the top 2" of the drive cap assembly so it engages the notches molded into the drive back plate around the top 2" of the piston cavity. See Figure 5. The notches are visible through the holes. Lever the screwdriver so the drive cap assembly turns counter clockwise. Once loosened unscrew the drive cap assembly by hand and pull straight out.

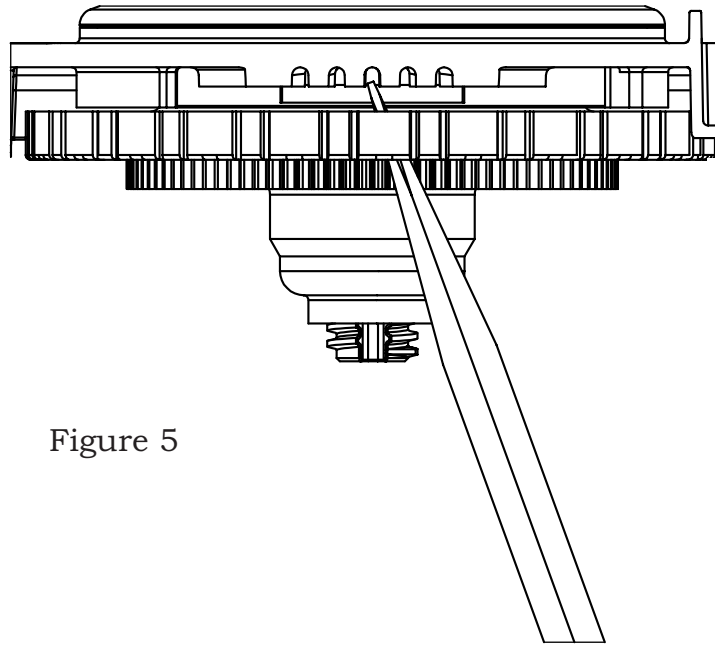

Figure 5

The drive cap assembly contains the drive cap, the main drive gear, drive cap spline, piston rod and various other parts that should not be disassembled in the field. The only replaceable part on the drive cap assembly is the o-ring. Attached to the drive cap assembly is the main piston and, if a regenerant is used, a regenerant piston.

The regenerant piston (the small diameter one behind the main piston) is removed from the main piston by unsnapping it from its latch. Chemically clean in dilute sodium bisulfite or vinegar or replace the regenerant piston if needed. To remove the main piston fully extend the piston rod and then unsnap the main piston from its latch by pressing on the side with the number. Chemically clean in dilute sodium bisulfite or vinegar or replace the main piston.

Reattach the main piston to the drive cap assembly. Reattach the regenerant piston (if needed) to the main piston. Do not lubricate the piston rod, main piston or regenerant piston. Lubricant will adversely affect the red or clear lip seals. Reinsert the drive cap assembly and piston into the spacer stack assembly and hand tighten the drive cap assembly. Continue to tighten the drive cap assembly using the special wrench or a screwdriver as a ratchet until the black o-ring on the spacer stack assembly is no longer visible through the drain port. Excessive force can break the notches molded into the drive back plate. Make certain that the main drive gear still turns freely. The exact position of the piston is not important as long as the main drive gear turns freely.

Reattach the drive assembly to the control valve and connect all plugs. After completing any valve maintenance, press and hold SET HOUR and DOWN buttons for 3 seconds or unplug power source jack (black wire) from the circuit board and plug back in. This resets the electronics and establishes the service piston position.

Spacer Stack Assembly

To access the spacer stack assembly remove the drive assembly, drive cap assembly and piston. The spacer stack assembly can be removed easily without tools by using thumb and forefinger. Inspect the black o-rings and red or clear lip seals for wear or damage. Replace the entire stack if necessary. The spacer stack assembly has been 100% tested at the factory to insure proper orientation of one way seals. Do not disassemble the stack.

The spacer stack assembly may be chemically cleaned (dilute sodium bisulfite or vinegar) or wiped with a soft cloth.

The spacer stack assembly can be pushed in to the control valve body bore by hand. Since the spacer stack assembly can be compressed it is easier to use a blunt object (5/8" to 1-1/8" in diameter) to push the center of the assembly into the control valve body. The assembly is properly seated when at least four threads are exposed (approximately 5/8"). Do not force the spacer stack assembly in. The control valve body bore interior can be lubricated with silicone to allow for easy insertion of the entire stack. Do not use silicone or any other type of lubricant on the red or clear lip seals or the piston.

Reattach the drive cap assembly and piston(s) and the drive assembly.

After completing any valve maintenance, press and hold SET HOUR and DOWN buttons for 3 seconds or unplug power source jack (black wire) from the circuit board and plug back in. This resets the electronics and establishes the service piston position.

Injector Cap, Screen, Injector Plug and Injector

Unscrew the injector cap and lift off. Loosen cap with special plastic wrench or pliers if necessary. Attached to the injector cap is a screen. Remove the screen and clean if fouled.

The plug and/or injector can be pried out with a small screwdriver. The plug can be wiped clean. If the plug leaks replace the entire plug. The injector consists of a throat and a nozzle. Chemically clean the injector with vinegar or sodium bisulfite. The holes can be blown out with air. Both pieces have small diameter holes that control the flow rates of water to insure that the proper concentration of regenerant is used. Sharp objects, which can score the plastic, should not be used to clean the injector. Scoring the injector or increasing the diameter of the hole could change the operating parameters of the injector.

Two holes are labeled DN and UP. Check for compliance with one of the following:

- a. for down flow systems, the appropriate size injector is located in the "DN" hole, a plug is in the "UP" hole and that the piston is a combination of the down flow main piston and the regenerant piston; or
- b. for backwash only systems, a plug is in the "DN" hole and in the "UP" hole, and that the piston only has a down flow main piston (the regenerant piston must be removed) and a plug is in the refill flow control position.

Push the plug(s) and/or injectors firmly in place, replace the screen and hand tighten the injector cap.

Refill Flow Control Assembly or Refill Port Plug

To clean or replace the refill flow control, pull out the elbow-locking clip and then pull straight up on the elbow. Replace the elbow locking clip in the slot so that it is not misplaced. Twist to remove the white flow control retainer. The flow control can be removed by prying upward through the side slots of the retainer with a small blade flat screwdriver.

Chemically clean the flow control or the white flow control retainer using dilute sodium bisulfite or vinegar. Do not use a wire brush. If necessary, replace the flow control, o-ring on the flow control retainer, or the o-ring on the elbow.

Reseat the flow control so the rounded end is visible in the flow control. Reseat the white flow control retainer by pushing the retainer into the elbow until the o-ring seats. Remove locking clip, push down on elbow to reseat and insert locking clip.

Do not use Vaseline, oils, or other unacceptable lubricants on o-rings. A silicon lubricant may be used on the o-ring on the elbow or the white retainer.

Meter Plug

This control valve does not come equipped with a meter, instead a plug is installed. The plug should not need to be serviced.

To remove the meter plug assembly, unscrew the meter cap on the left side of the control valve. Pliers may be used to unscrew the nut if necessary.

With the nut removed, a slot at the top of the meter plug is visible. Twist a flat blade screwdriver in the slot between the control valve body and the meter plug. When the meter plug is part way out it is easy to remove the meter plug from the housing.

Do not use a wire brush to clean. Wipe with a clean cloth or chemically clean in dilute sodium bisulfite or vinegar.

Do not use Vaseline, oils, or other unacceptable lubricants on the o-ring. A silicon lubricant may be used on the black o-ring.

Reinsert the meter plug into the side slot. Hand tighten the nut. Do not use a pipe wrench to tighten nut.

Bypass Valve

The working parts of the bypass valve are the rotor assemblies that are contained under the bypass valve caps. Before working on the rotors, make sure the system is depressurized. Turn the red arrow shaped handles towards the center of the bypass valve and back to the arrow direction several times to ensure rotor is turning freely.

The nuts and caps are designed to be unscrewed or tightened by hand. If necessary a pliers can be used to unscrew the nut or cap. Do not use a pipe wrench to tighten or loosen nuts or caps. Do not place screwdriver in slots on caps and/or tap with a hammer. To access the rotor, unscrew the cap and lift the cap, rotor and handle out as one unit. Twisting the unit as you pull it out will help to remove it more easily. There are three o-rings: one under the rotor cap, one on the rotor stem and the rotor seal. Replace worn o-rings. Clean rotor. Reinstall rotor.

When reinstalling the red arrow handles be sure that:

1. O-rings on both rotors face to the right when being viewed from the front of the control valve when the handle pointers are lined up with the control valve body arrows; or
2. Arrows point toward each other in the bypass position.

Since the handles can be pulled off, they could be accidentally reinstalled 180° from their correct orientation. To install the red arrow handles correctly, keep the handles pointed in the same direction as the arrows engraved on the control valve body while tightening the bypass valve caps.

After completing any valve maintenance, press and hold SET HOUR and DOWN buttons for 3 seconds or unplug power source jack (black wire) from the circuit board and plug back in. This resets the electronics and establishes the service piston position.

Table 6
Troubleshooting Procedures

Problem	Possible Cause	Solution
1. Timer does not display time of day	a. Transformer unplugged	a. Connect power
	b. No electric power at outlet	b. Repair outlet or use working outlet
	c. Defective transformer	c. Replace transformer
	d. Defective PC board	d. Replace PC board
2. Timer does not display correct time of day	a. Switched outlet	a. Use uninterrupted outlet
	b. Power outage	b. Reset time of day
	c. Defective PC board	c. Replace PC board
3. Control valve regenerates at wrong time of day	a. Power outages	a. Reset control valve to correct time of day
	b. Time of day not set correctly	b. Reset to correct time of day
	c. Time of regeneration incorrect	c. Reset regeneration time
4. E1, E2 or E3 E1 - Unable to recognize start of regeneration E2 – Unexpected stall E3 – Motor ran too long, timed out trying to reach the next cycle position or trying to reach home position	a. Control valve has just been serviced	a. Press SET HOUR and DOWN for 3 seconds or unplug power source jack (black wire) from the circuit board and plug back in to reset control valve
	b. Foreign matter is lodged in control valve	b. Check piston and spacer stack assembly for foreign matter
	c. High drive forces on piston	c. Replace piston(s) and spacer stack assembly
	d. Control valve piston not in home position	d. Press SET HOUR and DOWN for 3 seconds or unplug power source jack (black wire) from the circuit board and plug back in to reset control valve
	e. Motor not inserted fully to engage pinion, motor wires broken or disconnected, motor failure	e. Check motor and wiring. Replace motor if necessary
	f. Drive gear label dirty or damaged, missing or broken gear	f. Replace or clean drive gear
	g. Drive bracket incorrectly aligned to back plate	g. Reseat drive bracket properly
	h. PC board is damaged or defective	h. Replace PC board
	i. PC board incorrectly aligned to drive bracket	i. Ensure PC board is correctly snapped on to drive bracket
5. Control valve stalled in regeneration	a. Motor not operating	a. Replace motor
	b. No electric power at outlet	b. Repair outlet or use working outlet
	c. Defective transformer	c. Replace transformer
	d. Defective PC board	d. Replace PC board
	e. Broken drive gear or drive cap assembly	e. Replace drive gear or drive cap assembly
	f. Broken piston retainer	f. Replace drive cap assembly
	g. Broken main or regenerant piston	g. Replace main or regenerant piston
6. Control valve does not regenerate automatically when UP and DOWN buttons are depressed and held	a. Transformer unplugged	a. Connect transformer
	b. No electric power at outlet	b. Repair outlet or use working outlet
	c. Broken drive gear or drive cap assembly	c. Replace drive gear or drive cap assembly
	d. Defective PC board	d. Replace PC board
7. Control valve does not regenerate automatically but does when UP and DOWN buttons are depressed	a. Defective PC board	a. Replace PC board
	b. Set-up error	b. Check control valve set-up procedure

**BLACK, ORDER NO. V3010-1A
US Units**

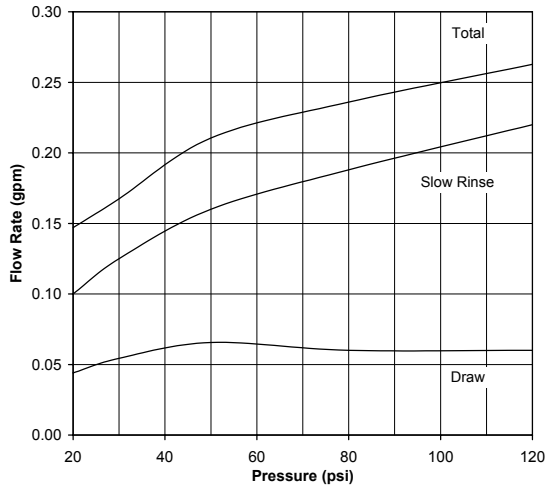

**BROWN, ORDER NO. V3010-1B
US Units**

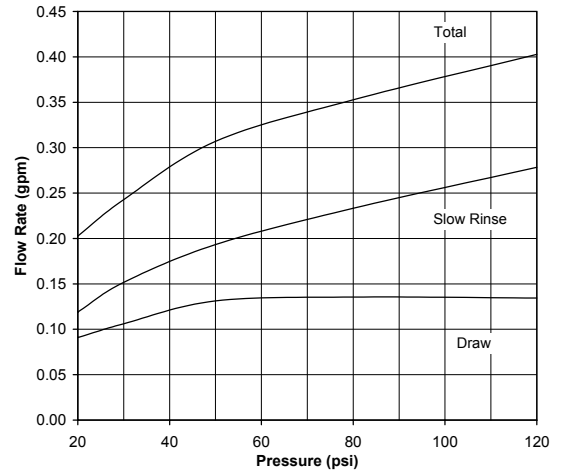

**VIOLET, ORDER NO. V3010-1C
US Units**

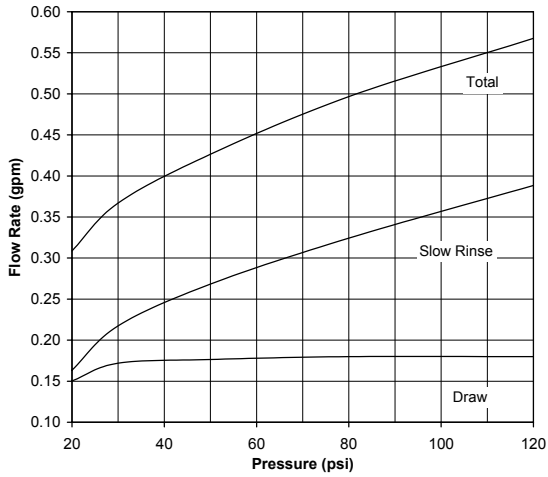

**RED, ORDER NO. V3010-1D
US Units**

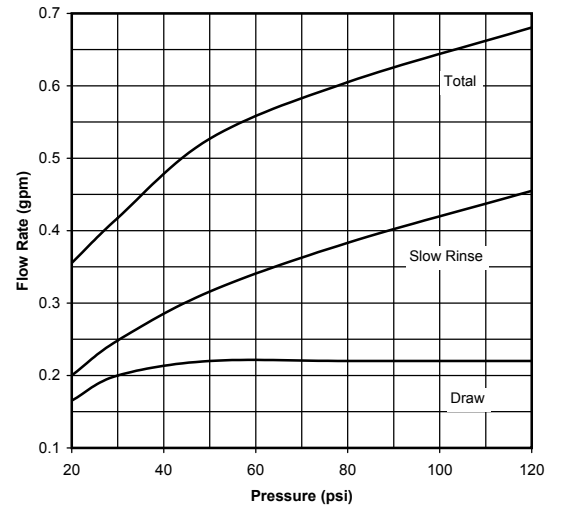

**WHITE, ORDER NO. V3010-1E
US Units**

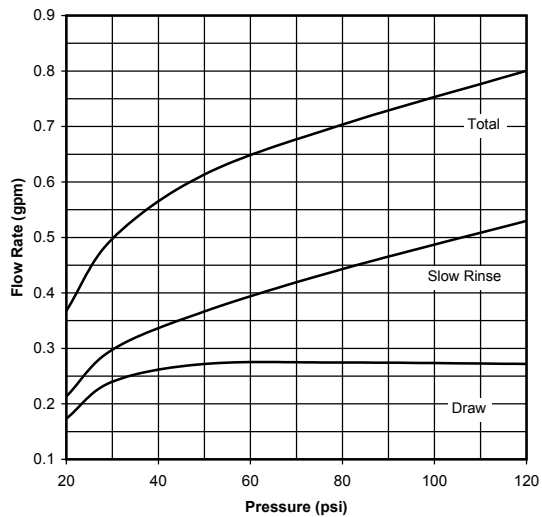

**BLUE, ORDER NO. V3010-1F
US Units**

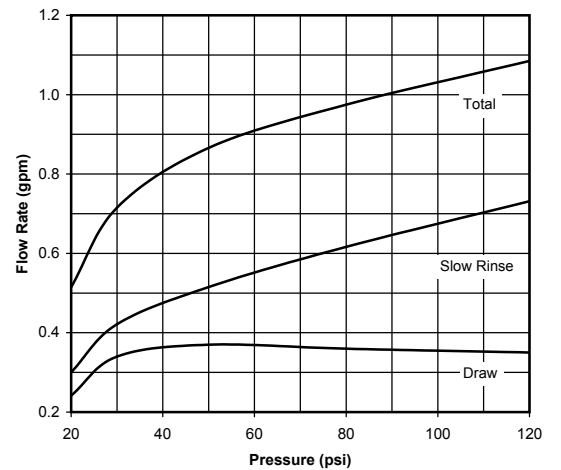

**YELLOW, ORDER NO. V3010-1G
US Units**

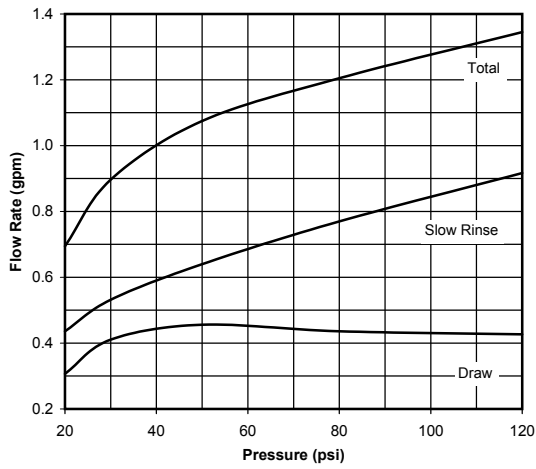

**GREEN, ORDER NO. V3010-1H
US Units**

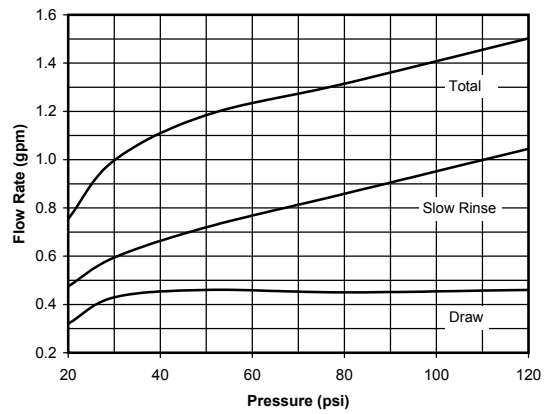

**ORANGE, ORDER NO. V3010-1I
US Units**

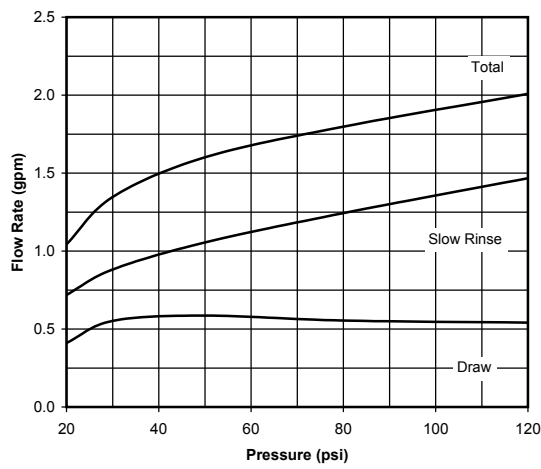

**LIGHT BLUE, ORDER NO. V3010-1J
US Units**

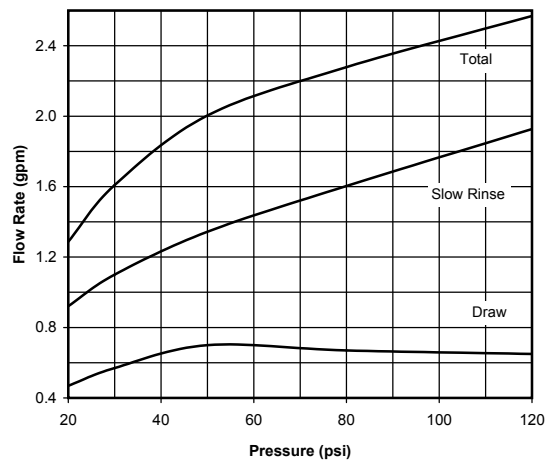

**LIGHT GREEN, ORDER NO. V3010-1K
US Units**

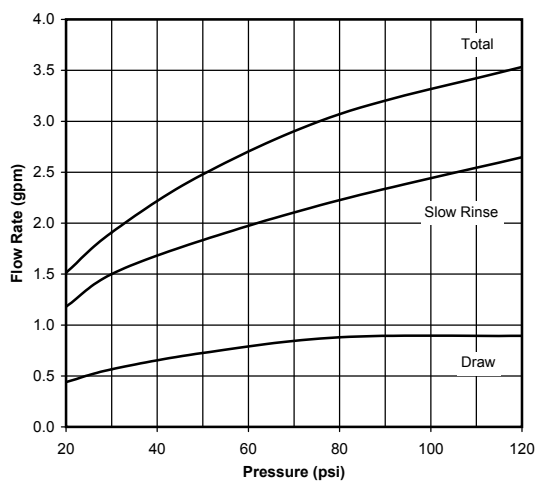

BLACK, ORDER NO. V3010-1A
Metric Units

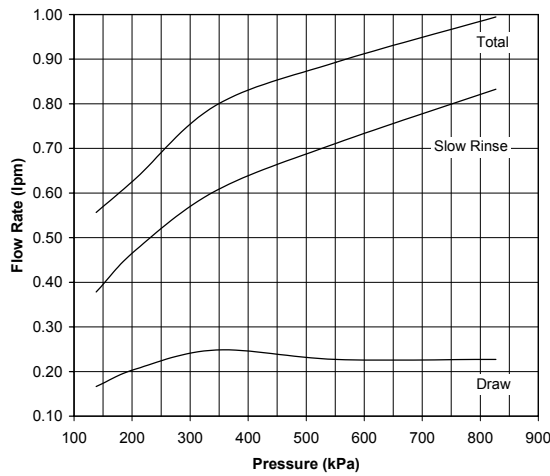

BROWN, ORDER NO. V3010-1B
Metric Units

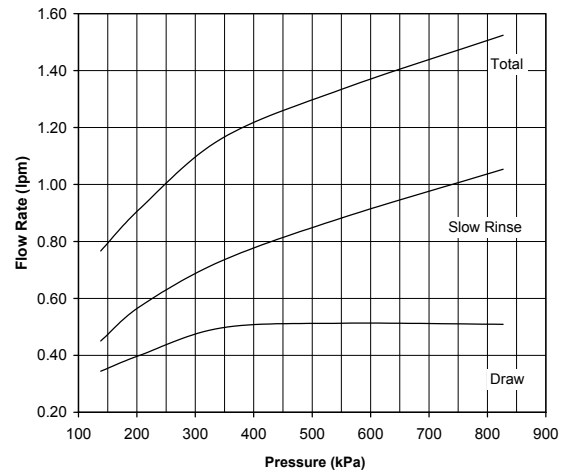

VIOLET, ORDER NO. V3010-1C
Metric Units

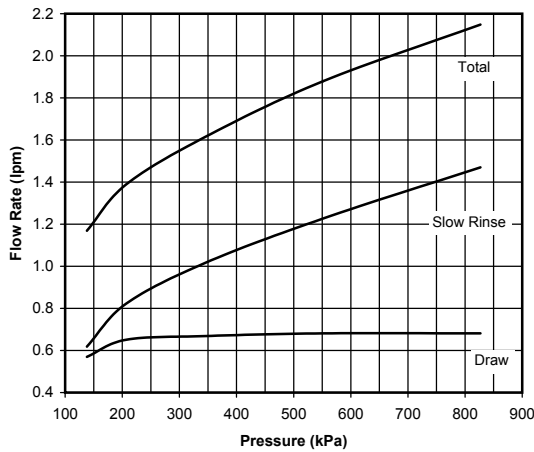

RED, ORDER NO. V3010-1D
Metric Units

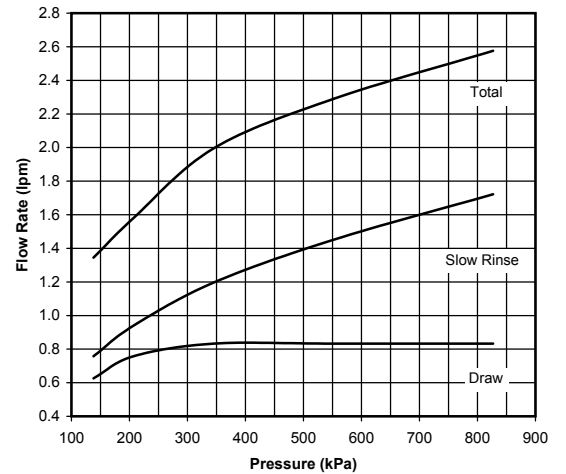

WHITE, ORDER NO. V3010-1E
Metric Units

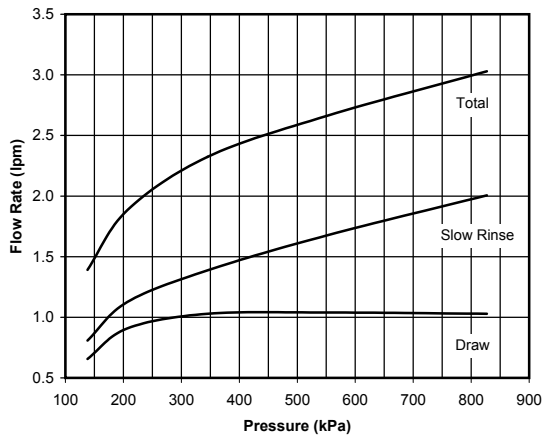

BLUE, ORDER NO. V3010-1F
Metric Units

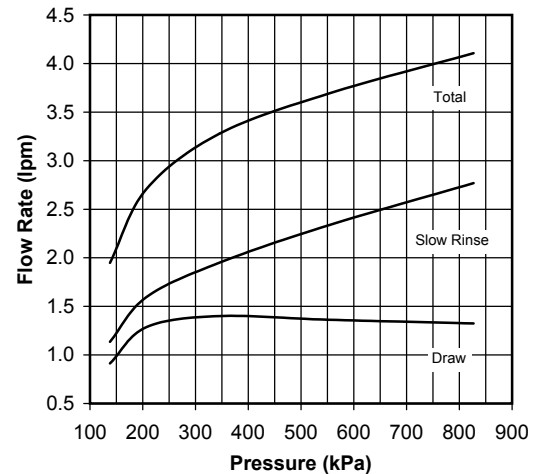

YELLOW, ORDER NO. V3010-1G
Metric Units

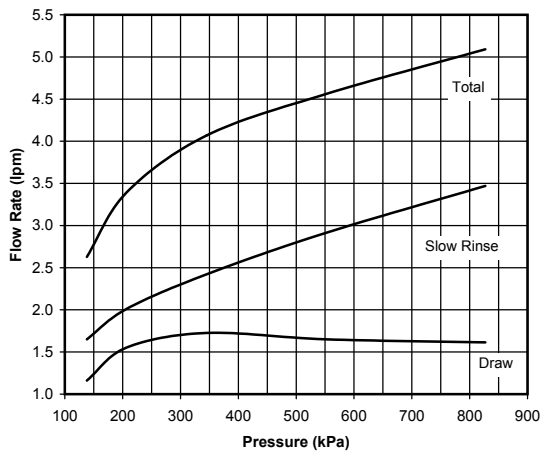

GREEN, ORDER NO. V3010-1H
Metric Units

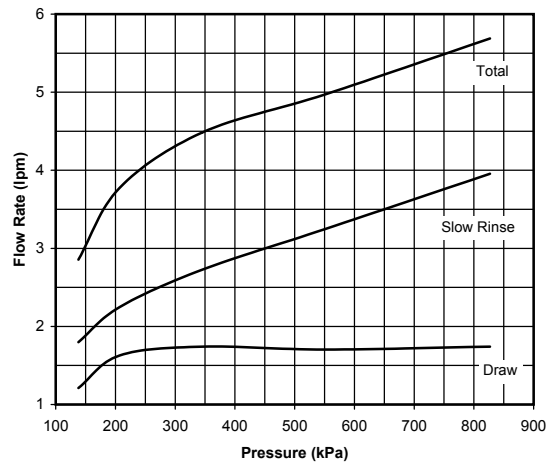

ORANGE, ORDER NO. V3010-1I
Metric Units

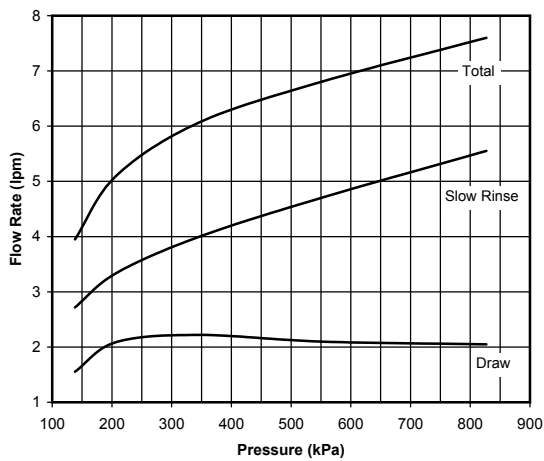

LIGHT BLUE, ORDER NO. V3010-1J
Metric Units

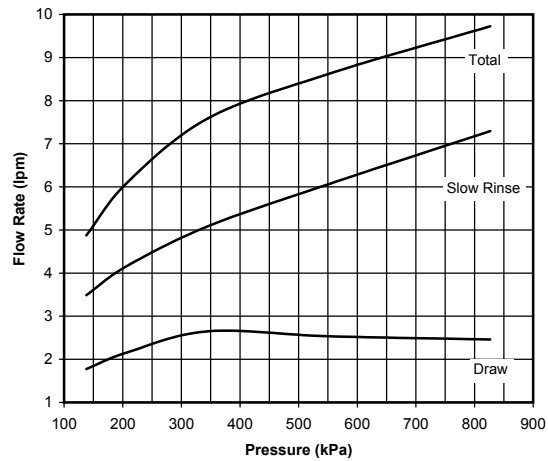

LIGHT GREEN, ORDER NO. V3010-1K
Metric Units

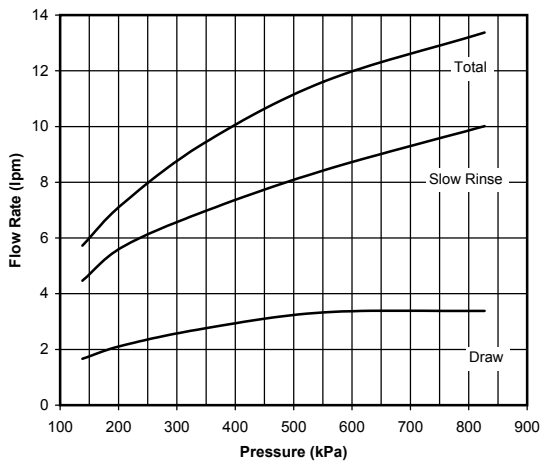

**CLACK CORPORATION
LIMITED WARRANTY**

Clack Corporation (“Clack”) warrants to OEM that the WS1 Valves will be free from defects in material and workmanship for a period of thirty-six (36) months from the date of shipment of such Valve from Clack’s plant in Windsor, Wisconsin when installed and operated within recommended parameters. No warranty is made with respect to defects not reported to Clack within the warranty period and/or defects or damages due to neglect, misuse, alterations, accident, misapplication, physical damage, or damage caused by fire, acts of God, freezing or hot water or similar causes. For outdoor installations where the WS1 Valves are not under cover, the weather cover must be utilized for the warranty to be valid.

Clack’s obligation to OEM under this Limited Warranty shall be limited, at its option, to replacement or repair of any WS1 valve covered by this Limited Warranty. Prior to returning a WS1 Valve, OEM must obtain a return goods authorization number from Clack and return the WS1 Valve freight prepaid. If any WS1 Valve is covered under this Limited Warranty, Clack shall return the WS1 Valve repaired, or its replacement, prepaid to the original point of shipment.

CLACK GIVES THIS WARRANTY TO OEM IN LIEU OF ALL OTHER WARRANTIES, EXPRESS OR IMPLIED, INCLUDING WITHOUT LIMITATION ANY IMPLIED WARRANTIES OF MERCHANTABILITY OR FITNESS FOR A PARTICULAR PURPOSE AND HEREBY EXPRESSLY DISCLAIMS ALL OTHER SUCH WARRANTIES. CLACK’S LIABILITY HEREUNDER SHALL NOT EXCEED THE COST OF THE PRODUCT. UNDER NO CIRCUMSTANCES WILL CLACK BE LIABLE FOR ANY INCIDENTAL OR CONSEQUENTIAL DAMAGES OR FOR ANY OTHER LOSS, DAMAGE OR EXPENSE OF ANY KIND, INCLUDING LOSS OF PROFITS, ARISING IN CONNECTION WITH THE INSTALLATION OR USE OR INABILITY TO USE THE WS1 VALVES OR ANY WATER TREATMENT SYSTEM THE WS1 VALVE IS INCORPORATED INTO.

