



## INSTALLATION AND OPERATING INSTRUCTIONS FOR AUTOMATIC INSTANTANEOUS TYPE WATER HEATERS FOR USE WITH NATURAL AND LIQUEFIED PETROLEUM GAS

### MODEL 125B LP and 125B NG (Flow Modulated)

Suitable for heating potable water only

Not approved for space heating purposes

Intended for variable flow applications with steady cold water inlet temperatures only



#### WARNING

If the information in this manual is not followed exactly, a fire or explosion may result causing property damage, personal injury or death.

#### FOR YOUR SAFETY

Do not store or use gasoline or other flammable, combustible or corrosive vapors and liquids in the vicinity of this or any other appliance.

#### WHAT TO DO IF YOU SMELL GAS

- Do not try to light any appliance.
- Do not touch any electrical switch; do not use any phone in your building.
- Immediately call your gas supplier from a neighbor's phone. Follow the gas supplier's instructions.
- If you cannot reach your gas supplier, call the fire department.
- Installation and service must be performed by a qualified installer, service agency or the gas supplier.

#### TABLE OF CONTENTS

Specifications .....	Page 2
Rules for safe operation .....	Page 4
Locating the Heater .....	Page 4
Combustion Air Requirements .....	Page 5
Mounting the Heater .....	Page 5
Venting the Heater .....	Page 6
Gas Connections .....	Page 7
Water Connections .....	Page 9
Safety before lighting the pilot .....	Page 9
Lighting instructions .....	Page 10
Setting water temperature .....	Page 10
Maintenance & Service .....	Page 10
Trouble Shooting .....	Page 11
Diagram of AquaStar .....	Page 14
Components and Parts List .....	Page 15



**WARNING:** Improper installation, adjustment, alteration, service or maintenance can cause injury or property damage. Refer to this manual. For assistance or additional information consult a qualified installer, service agency or the gas supplier. Upon completion of the installation, these instructions should be handed to the user of the appliance for future reference.

In the Commonwealth of Massachusetts this product must be installed by a licensed plumber.

FEATURING: Automatic Variable Power Modulating Gas Valve

**This well engineered, gas water heater has all the features a water heater should have:**

It operates on the principle of heating water instantaneously "on demand". When a hot water faucet is opened, cold water flows through the coils of the heat exchanger in the Aquastar. This same flow opens the gas valve, and the burners are ignited by the pilot flame. The heat exchanger coils absorb the heat generated by the burners and transfer heat to the water. When the hot water faucet is shut off, the gas valve automatically closes and the burners turn off. Your hot water faucet is an ignition key to turn on the water heater, giving you control over your hot water energy use. Each time you turn off your hot water faucet, you also shut off the water heater.

**FEATURES**

- High Quality Materials for Long Working Life.
- Copper heating coils for endless supply of hot water.
- Burner output proportional to hot water flow demand for maximum energy efficiency.
- Safety thermocouple at pilot burner.
- Automatic overheating protection shut-off sensor.
- Flue gas safety device.
- Stainless steel burners with stabilized blue flame.
- Built-in corrosion resistant draft inducer.
- Compact space saver: mounts on a wall with two hooks.
- Easily removable one-piece cover.
- Easy one person installation.
- Adjustable water flow restrictor to ensure that water flow demand will not exceed the heating capacity of the heater.
- Easy pilot flame lighting with push button piezo ignition.

**BOSCH is constantly improving our products, therefore specifications are subject to change without prior notice.**

**AquaStar 125B LP and 125B NG Specifications**

Gas Input max.: 117,000 Btu/hr  
min.: 28,000 Btu/hr

Water Connection 1/2" Thread fitting NPT

H x W x D 29 3/4" x 18 1/4" x 8 3/4"

Vent 5"

CATEGORY I GAS APPLIANCE

Gas Connection 1/2" NPT thread

Min. Water Pressure 18 Psi at 4 GPM

Max. Water Pressure 150 Psi

Shipping Weight 42 LB

Net Weight 39 LB

1.8 GPM at 90° rise

3.7 GPM at 45° rise

Min. Water Flow 1/2 gal/min

LP GAS Supply Pressure (before Aquastar regulator) min. 11" W.C.  
max. 14" W.C.\*

Required LP GAS pressure at inlet tap while Aquastar is operating: 10.5" W.C.

LP GAS Burner Manifold pressure while Aquastar is operating at maximum input: 9.0" W.C.

Natural Gas Supply Pressure (before Aquastar regulator) min.: 7" W.C.  
max.: 14"W.C.\*

Required Natural Gas Pressure at inlet tap while Aquastar is operating: 5.7"W.C.

Natural Gas Burner Manifold pressure while Aquastar is operating at maximum input: 4.2" W.C.

\* Inlet gas pressure before Aquastar regulator must not exceed this value. Pressure may need to be adjusted for high altitudes, see page 7.

**UNPACKING THE AQUASTAR HEATER**

This heater is packed securely. The box includes one water connection fitting, a control knob, a gas pressure regulator, a pressure relief valve, an incandescent particle tray, two hooks for hanging the heater, this manual, a warranty statement and a warranty registration card. **Do not lose this manual, as there is a charge for replacement.** Please complete and return the enclosed warranty registration card.

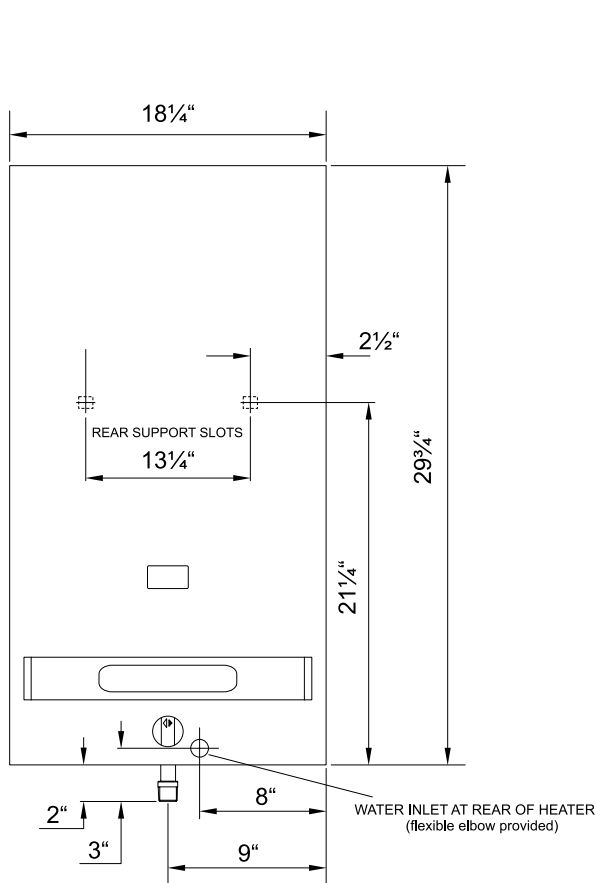

FRONT VIEW

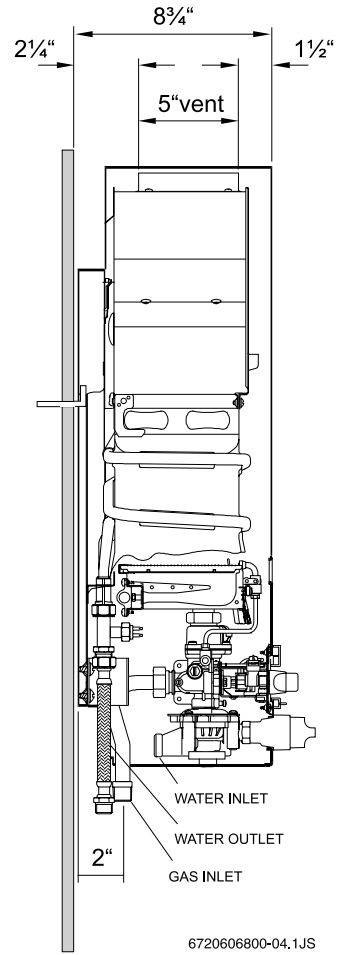

SIDE VIEW

6720606800-04.1JS

## MINIMUM INSTALLATION CLEARANCES FROM COMBUSTIBLE AND NON COMBUSTIBLE MATERIALS FOR ALCOVE OR CLOSET INSTALLATIONS

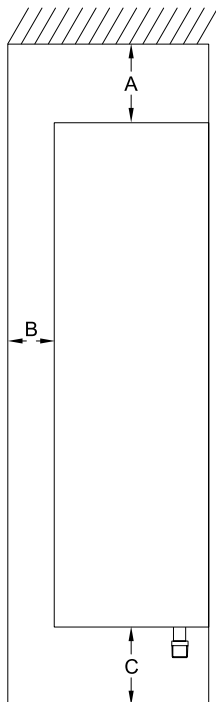

	MODEL 125B
TOP (A)	12 "
FRONT (B)	4 "
BACK	0 "
SIDES	4 "
FLOOR (C)	12 " *
VENT DIAMETER	5 "

\* Some local codes require 18" in garage installations

### AQUASTAR MODEL 125B

## GENERAL RULES TO FOLLOW FOR SAFE OPERATION

1. You should follow these instructions when you install your heater. In the United States: The installation must conform with local codes or, in the absence of local codes, the National Fuel Gas Code ANSI Z223.1/NFPA 54.

In Canada: The Installation should conform with CGA B149.(1,2) INSTALLATION CODES and /or local installation codes.

2. Carefully plan where you install the heater. Correct combustion air supply and flue pipe installation are very important. If not installed correctly, fatal accidents can be caused by lack of air, carbon monoxide poisoning or fire.

3. The place where you install the heater must have enough ventilation. The National Fire Codes do not allow gas fired water heater installation in bathrooms, bedrooms or any occupied rooms normally kept closed. See the section below on locating the heater.

4. You must vent your heater. See section on Venting, Page 6.

5. The appliance must be disconnected from the gas supply piping system during any pressure testing at pressures in excess of 1/2 Psig (3.5 kPa).

The appliance must be isolated from the gas supply piping system by closing its individual manual shutoff valve during any pressure testing of the gas supply piping system at test pressures equal to or more than 1/2 Psig (3.5Kpa). The appliance and its gas connection must be leak tested before placing the appliance in operation.

6. Keep water heater area clear and free from combustibles and flammable liquids. Do not locate the heater over any material which might burn.

7. **Correct gas pressure** is critical for the optimum operation of this heater (see specifications on page 2). Gas piping must be sized to provide the required pressure at the maximum output of the heater, while all the other gas appliances are in operation. Check with your local gas supplier, and see the section on connecting the gas supply.

8. Should overheating occur or the gas supply fail to shut off, turn off the gas supply at the manual gas shut off valve on the gas line.

9. Do not use this appliance if any part has been underwater. Immediately call a qualified service technician to inspect the appliance and to replace any part of the control system and any gas control which has been underwater.

## PROPER LOCATION FOR INSTALLING YOUR HEATER

Carefully select the location of your new heater. For your safety and for proper heater operation, you must provide an abundant supply of combustion air and a proper venting installation.

The heater may still operate even when improperly vented. It will, however, be less efficient and could eventually damage the heater. It could even result in human sickness or death due to oxygen deprivation and carbon monoxide poisoning. Follow the guidelines below:

1. Place your heater as close to a vent or chimney as possible.

2. National building codes require that you do not install this appliance in bathrooms, bedrooms, unvented closet or any occupied rooms normally kept closed.

3. Simultaneous operation of other appliances such as exhaust fans, ventilation systems clothes dryers, fireplaces or wood stoves could create a vacuum effect in your home which could cause dangerous combustion by-products to spill back into your home rather than venting to the outside through the flue. Confirm that your Aquastar is venting properly when all these other appliances are running. See section on venting.

**Do not obstruct the flow of combustion and ventilation air to the appliance.** If installed near a clothes dryer it is very important that the dryer be properly vented. Failure to properly vent a dryer could result in a gradual accumulation of lint on the water heater fin coils and burners, leading to a dangerous condition of vent blockage and poor unsafe combustion.

4. Your hot water lines should be kept short to save energy. It is always best to have hot water lines insulated.

**This product is not approved for manufactured homes (mobile home), recreational vehicles (RV) or boats. Reference ANSI Z21.10.3.**

**This product is neither designed or approved for outside installations.**



**WARNING:** The water in this water heater is cold and always remains cold except for the times that hot water is being used **DO NOT INSTALL IN AN AREA WHERE IT COULD FREEZE.**

**This heater is neither designed for nor approved for outside installation.**

Drain the heater entirely if freezing temperatures are anticipated in area where heater is installed by disconnecting both the inlet and outlet water connections from the heater (disconnect the outlet flex line from where it connects to the copper heat exchanger). Additionally, remove the drain plug under the water valve. See Fig 0.

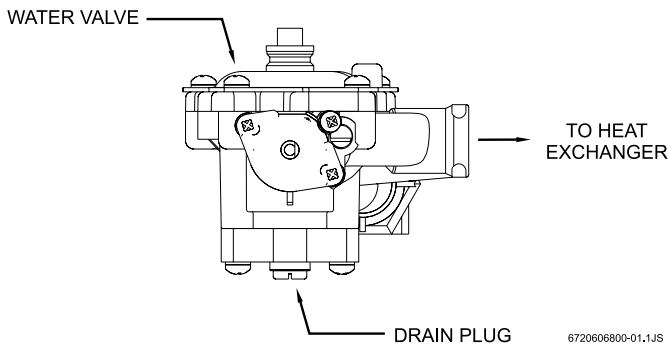

**Fig. 0 - Water heater drain plug**

**⚠ WARNING: Flammable materials, gasoline, pressurized containers, or any other items or articles that are potentially fire hazards must NOT be placed on or adjacent to the heater. The appliance area must be kept free of all combustible materials, gasoline and other flammable vapors and liquids.**

## COMBUSTION AIR REQUIREMENTS

The AquaStar water heater holds cold water in its copper heat exchanger and brass water valve when not in use. Because of this, any cold air that comes in through the unit's vent pipe is capable of freezing these components. This Installation Manual specifies the minimum vertical vent pipe and the amount of combustion air required for this unit. The vent pipe must not be restricted and its 6 foot minimum height (provided there are no elbows) must terminate 2 feet above any obstruction within a 10 foot radius.

When all requirements are followed, the unit will operate properly and safely. However, there may still be a risk of freezing due to negative draft if all the combustion appliances in the area are not being supplied with a sufficient amount of make-up air. A wood stove or furnace can rob the make-up air in the AquaStar's vent pipe, leaving the cold infiltrating air capable of freezing the cold water in the AquaStar heat exchanger. More make up air is the solution. Follow the instructions on venting and checking adequacy of make up air. A HVAC specialist should be used to design solutions for providing more make-up air if necessary.

Observe the following instructions concerning combustion air.

Appliances located in unconfined spaces:

- a) An unconfined space is one whose volume is greater than 50 cubic feet per 1000 Btu per hour of the combined rating of all appliances installed in the space. That would be 5850 cubic feet for the AquaStar 125B alone.
- b) In unconfined spaces in buildings of conventional frame, masonry, or metal construction, infiltration is normally adequate to provide air for combustion, ventilation, and dilution of flue gasses.

Appliances located in confined spaces:

The confined space must be provided with two permanent openings, one commencing within 12 inches of the top and one commencing within 12 inches of the bottom of the enclosure. Each opening must have a minimum free area of one square inch per:

- 1000 Btu/hr if all air is taken from inside the building.
- 2000 Btu/hr if all air is taken from the outside by horizontal ducts.
- 4000 Btu/hr if all air is taken from the outside by direct openings or vertical ducts.

Or the confined space must be provided with one permanent opening or duct that is within 12 inches of the ceiling of the enclosure. This opening must have a minimum free area of one square inch per:

- 3000 Btu/hr if all air is taken from the outside by a direct opening or vertical duct.

Louvers, grills and screens have a blocking effect. If the effective free area is not known, increase the sizes of your openings by 75% if your louvers are wood and by 30% if your louvers are metal. Refer to the National Fuel Gas Code for complete information. In buildings of tight construction all air should be taken from outside.

## CLEARANCES

The Aquastar 125 B is design certified for installation on a combustible wall and for installation in an alcove or closet with the minimum clearances to combustible and non-combustible construction listed below

- A. Top 12 inches (306 mm)
- B. Front 4 inches (102 mm)
- C. Back 0 inches
- D. Sides 4 inches (102mm)
- E. Bottom 12 inches (306 mm)

Clearance from vent is dependent upon the clearance rating of the venting material used. For example: type B-1 vent is approved for 1 inch clearance.

**Note:** Minimum clearance to combustible materials should not be less than 6" for single wall flue pipe. Note that this clearance can be reduced if combustible material are protected as per table VI of the National fuel Gas Code or if Type B gas vent is used.

## MOUNTING INSTALLATION

The Aquastar 125 B is design certified for mounting on a wall.

Secure the two L shaped hooks, which are provided with heater, to a wall surface. Place them 13 ¼" apart as shown in Fig. 1.

Do not install this appliance on a carpeted wall or over floor covering which is combustible, such as carpet. The heater must be mounted on a wall using appropriate anchoring materials. If wall is a stud wall sheathed with plasterboard, **it is recommended that support board(s), either 1x4's or 1/2" (minimum) plywood first be attached across a pair of studs and then the heater should be attached to the support boards. See Fig 1.**

Expansion and contraction of piping due to changing water temperature in the pipes imparts movement to the heater which, if mounted directly to a brittle, friable board, such as plasterboard, can cause failure of mounting.

In earthquake-prone zones, CEC recommends that installers use a large washer and lag screw through the existing holes used to hang the heater to affix the upper third of the heater to the mounting board. To affix the lower third of the heater, CEC recommends that two new holes be drilled in the heater's frame, each one 16 inches below the top two holes, and that washers and lag screws be used to secure the lower portion of the heater to a spacing board.

*Before installing the unit, be certain you have the correct heater for your type of Gas – Propane or Natural Gas. Identification labels are found on the shipping box, and on the rating plate which is located on the right side panel of the cover. Also, each burner orifice is stamped with a number (79 for LPG and 120 for Natural Gas).*

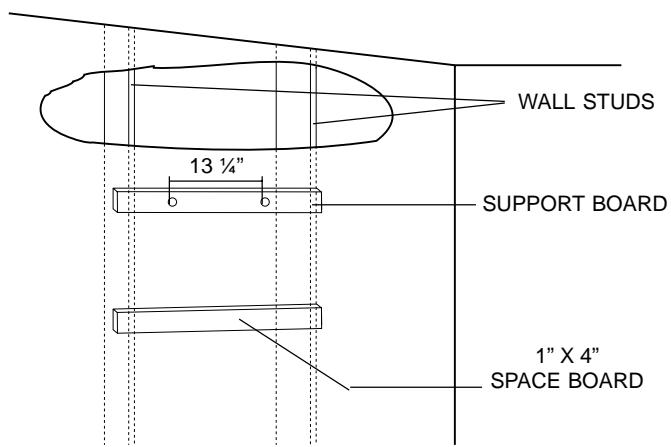

**Fig. 1 - Mounting the Heater**

The incandescent particle tray (shipped loose in the carton with the water heater) must be attached at the bottom of the water heater front cover at the time of installation. Use the screws provided. See figure 2

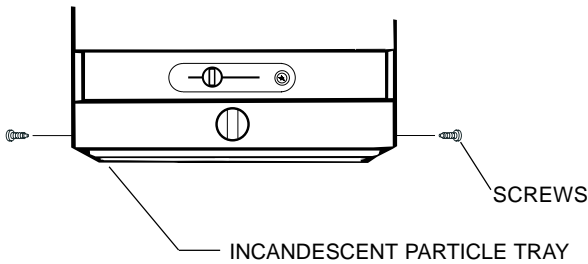

**Fig. 2 - Incandescent Particle Tray Illustration**

## VENTING

**! WARNING: Do not reduce the vent pipe size.**

This appliance must be vented to the outside following all local ordinances and specifications for installing a gas appliance vent or chimney. The venting system must be designed and constructed so as to develop a positive flow adequate to remove flue gasses to the outdoors. **Minimum vent size must be 5". Minimum height must be 6 feet, provided there are no elbows. Termination of vent must be 2 feet above any obstruction within a 10 foot radius.**

**Consult your gas utility or National Fuel Gas Code if vent will have elbows or share venting with another appliance. The vent connector should have as much vertical rise as possible (minimum 12") before any horizontal run.**

The appliance must be located as close as practicable to a chimney or vent. The vent pipe sections must be secured to each other with sheet metal screws. Keep in mind the minimum clearance from the top of your heater. Remember also that single wall vent pipe connectors require a 6 inch clearance from combustibles. National Fuel Gas Code specifies double wall — Type "B" — vent pipe be used in cold climates and for gas vents running through attics. We consider double wall vent pipe preferable in all circumstances. Any vent section greater than 45 degrees from vertical is considered horizontal. Horizontal sections of vent connectors must slope upwards at least 1/4 inch for every foot of its horizontal length. Keep the horizontal section short and avoid too many elbows.

Optional powervent available in order to sidewall vent.

**In the Commonwealth of Massachusetts: Powervented applications must utilize proof-of-draft safety interlock device.**

Contact your local dealer.

**To check the draft:**

Close all doors and windows to the outside.

Turn on all appliances that force air out of the building. These include all exhaust/ventilation fans, furnaces, clothes dryers, wood burning stoves, etc.

Open all doors between the AquaStar and these other appliances.

With the control knob set fully clockwise and strong hot water flow rate, run the unit for at least 10 minutes. The 125B is equipped with a Flue Gas Sensor; it's mounted on the right side of the draft diverter (Flue Gas Sensor #20 on page 17). If the main burners and the pilot flame shut off during this test it is because the Flue Gas Sensor has detected inadequate venting. This is a serious health hazard and must be corrected. Poor venting can result in soot building up inside the heater, overheating of the heater and freezing of the heat exchanger in a freezing environment, which is all a result of negative air flow. Additional combustion air and/or improved venting will be necessary to correct this.

## **! WARNING**

**Note:** The burners of an instantaneous "on demand" water heater such as the AquaStar are only on at the time that hot water is actually being used, the vent pipe is therefore cold except for the short durations when hot water is being used, it is therefore very important that the venting and air supply be adequate to provide a good positive draft as soon as the burners turn on. See venting guide on back page. The AquaStar 125B instantaneous water heaters have built-in draft diverters and are designed for indoor installation only. The draft diverter outlet must be connected to a clear, unobstructed vent of the same size, or larger.

In Canada, CAN/CGA-B149 Installation Code for detailed requirements

In U.S.A., ANSI Z223.1 - NFPA 54, national Fuel Gas Code for detailed requirements.

The vent connection for the AquaStar 125B is 5 inches. However, **IN CANADA**, for installations at high altitude (2000-4500 feet above sea level) a six inch flue is required. A 5" by 6" flue adaptor must be affixed to the flue collar of the AquaStar with at least two screws. See figure 3.

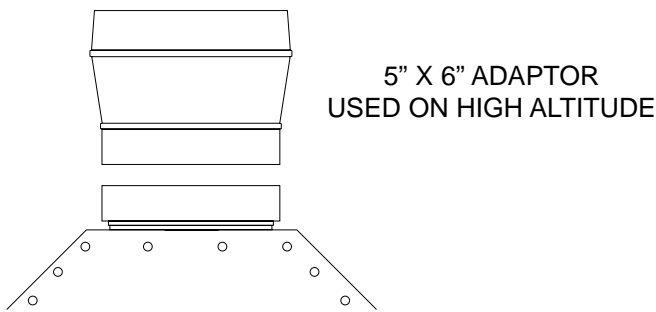
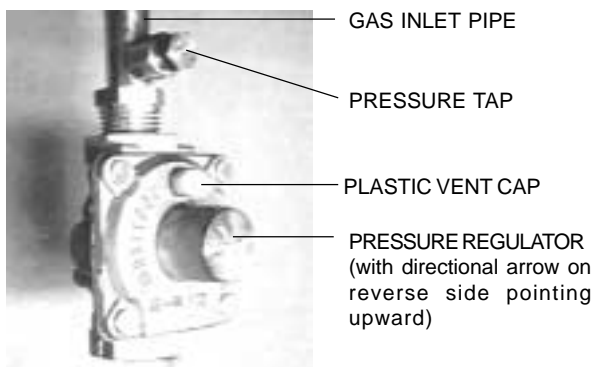

**Fig. 3 - Vent Adaptor for High Altitude Canadian Installations**

**⚠ WARNING:** Failure TO INCREASE THE VENT SIZE TO SIX INCHES AND/or assure that the manifold pressure is set to proper value listed for applications at high altitudes will cause unsafe venting, asphyxiation, and will void CSA Certification.

## GAS CONNECTIONS and Gas Regulator

**NOTE:** The AquaStar 125 B is supplied with a gas pressure regulator that must be installed on the heater before attaching the gas supply line. See figure 4. Failure to install the gas regulator as shown in figure 4 will be a violation of CSA certification of the unit. The regulator supplied with the heater is preset for the gas shown on the rating plate to the correct pressure. It is an appliance level regulator designed for (low inlet) pressure (less than 1/2 Psig or 15" W.C.) **DO NOT** connect to an unregulated or high pressure propane line or to a high pressure commercial natural gas line.



**Fig. 4 - Installation of Gas Pressure Regulator**

The pressure regulator provided with the heater is adjusted to deliver the proper gas pressure (as indicated on the rating plate and in the manual for altitude up to 2000 feet (660 meters) above sea level. On appliances being installed above 2000 ft (660 meters) elevation, the inlet gas pressure should be set at installation to the value shown below.

**NOTE:** The gas pressures specified below refer to pressures taken at the pressure tap on the gas inlet

pipe just above the regulator (See Fig 4).

These readings should be taken while the heater is operating at full input — i.e. maximum water flow with the temperature dial selector turned all the way clockwise.

### MAXIMUM INLET GAS FLOW PRESSURE SETTING

Altitude	Natural Gas inches W.C:	Liquid Propane inches W.C:
0' - 2,000 ft	5.7"	10.5"
2,000 ft - 4,500 ft	4.6"	8.4"

Above 4,500 ft consult your local gas supplier.

### GAS LINE SIZING

-It is strongly recommended that the Natural Gas pipe be Black Iron pipe the entire distance from the outside meter to the inlet of the AquaStar regulator. 1/2" Black Iron pipe up to 10 feet, 3/4" Black Iron pipe up to 40 feet and 1" Black Iron pipe up to 150 feet distances. Flex line tubing is NOT recommended, but if used then oversize it.

-It is strongly recommended that the LP Gas pipe be semi-rigid copper or Black Iron pipe from the outside regulator to the inlet of the AquaStar regulator. For semi-rigid copper piping: 5/8" up to 20 feet and 3/4" up to 60 feet distances. For Black Iron piping: 1/2" up to 45 feet and 3/4" up to 160 feet distances. Flex line tubing is NOT recommended, but if used then oversize it.

**THESE FIGURES ARE FOR AQUASTAR SUPPLY ONLY, ALL OTHER APPLIANCES IN THE BUILDING WILL NEED TO BE INCLUDED IN THE PIPE SIZING.**

National Fuel Gas Code requires that a sediment trap (drip leg) be installed on gas appliances not so equipped. The drip leg must be accessible and not subject to freezing conditions. Install in accordance with the recommendations of the serving gas supplier.

**⚠ WARNING:** The heater must be disconnected from the gas supply piping system during any pressure testing of that system at test pressures in excess of 0.5 psig.

The water heater must be isolated from the gas supply piping system by closing the manual shutoff valve during any pressure testing of the gas supply piping system at test pressures equal to or more than 0.5 psig.

The water heater, including the pressure regulator provided with it, must not be operated at gas supply pressures in excess of 0.5 psig. If overpressure has occurred, such as through improper testing of the gas lines or malfunction of the supply system, the gas valve and regulator must be checked for safe operation. Make sure that the regulator vent is protected against blockage.

When your connections are made, check for gas leaks at all joints (not just the ones you made). Apply some soapy water to all gas fittings and gas valve. **Soap bubbles are a sign of a leak.**

**NOTE:** Do not apply soap solution to pilot filter screen or pilot orifice area. If you have a leak, shut off the gas. After verifying that required gaskets are in place, tighten appropriate fittings to stop leak. Turn the gas on and check again with a soapy solution. **Never test for gas leaks using a match or flame.**

# GAS PIPING, CONNECTIONS and Gas Regulator

Before connecting the gas supply, check the rating plate on the right side of the front cover to be sure that the heater is rated for the same gas to which it will be connected.

In the United States: The installation must conform with local codes or, in the absence of local codes, the National Fuel Gas Code ANSI Z223.1/NFPA 54.

In Canada: The Installation should conform with CGA B149 INSTALLATION CODES and /or local installation codes.

## GAS LINE SIZING

### FOR NATURAL GAS

Maximum Capacity of pipe in Cubic Feet of Gas per Hour for Gas Pressure of 0.5 Psig or less and a Pressure drop of 0.3 in Water Column.

Follow boxed numbers for piping just one Aquastar 125B (example: 3/4" B.I. Natural Gas pipe for 30 ft. will handle 152,000 btu's). For multiple appliances combine the total btu input load and then refer to applicable chart below.

(Based on a 0.60 Specific Gravity Gas) Btu numbers given in thousands.

Nominal		Length of Black Iron Pipe, Feet														
Pipe Size,	Internal Diameter	10	20	30	40	50	60	70	80	90	100	125	150	175	200	
inches	inches															
1/4	0.364	32	22	18	15	14	12	11	11	10	9	8	8	7	6	
3/8	0.493	72	49	40	34	30	27	25	23	22	21	18	17	15	14	
1/2	0.622	132	92	73	63	56	50	46	43	40	38	34	31	28	26	
3/4	0.824	278	190	152	130	115	105	96	90	84	79	72	64	59	55	
1	1.049	520	350	285	245	215	195	180	170	160	150	130	120	110	100	
1 1/4	1.380	1050	730	590	500	440	400	370	350	320	305	275	250	225	210	
1 1/2	1.610	1600	1100	890	760	670	610	560	530	490	460	410	380	350	320	
2	2.067	3050	2100	1650	1450	1270	1150	1050	990	930	870	780	710	650	610	
2 1/2	2.469	4800	3300	2700	2300	2000	1850	1700	1600	1500	1400	1250	1130	1050	980	
3	3.068	8500	5900	4700	4100	3600	3250	3000	2800	2600	2500	2200	2000	1850	1700	
4	4.026	17,500	12,000	9,700	8,300	7,400	6,800	6,200	5,800	5,400	5,100	4,500	4,100	3,800	3500	

### FOR LP GAS

Maximum Capacity of Pipe in Thousands of BTU per Hour of Undiluted Petroleum Gases (at 11 inches Water Column Inlet Pressure) (Based on a Pressure Drop of 0.5 Inch Water Column).

Nominal Iron Pipe Size, Inches	Black Iron Pipe Length of Pipe, Feet													
	10	20	30	40	50	60	70	80	90	100	125	150		
1/2	275	189	152	129	114	103	96	89	83	78	69	63		
3/4	567	693	315	267	237	217	196	185	173	162	146	132		
1	107	732	590	504	448	409	378	346	322	307	275	252		
1 1/4	220	149	121	103	913	834	771	724	677	630	567	511		
1 1/2	330	229	185	155	141	127	118	108	102	976	866	787		
2	622	433	346	299	264	239	220	204	192	1811	1606	1496		

Maximum Capacity of Semi-Rigid Tubing in Thousands of BTU per Hour of Undiluted Liquefied Petroleum Gases (at 11 inches Water Column Inlet Pressure)

(Based on a Pressure Drop of 0.5 Inch Water Column)

Outside Diameter, Inch	Copper Length of Tubing, Feet									
	10	20	30	40	50	60	70	80	90	100
3/8	39	26	21	19	-	-	-	-	-	-
1/2	92	62	50	41	37	35	31	29	27	26
5/8	199	131	107	90	79	72	67	62	59	55
3/4	329	216	181	145	131	121	112	104	95	90
7/8	501	346	277	233	198	187	164	155	146	138

\* Source National Fuel Gas Code NFPA 54, ANSI Z223.1 - No Additional Allowance is necessary for an ordinary number of fittings



## WATER CONNECTIONS

When facing the heater, the cold water inlet is on your right and the hot water outlet is on your left.

Although water piping throughout your structure may be other than copper, we recommend that copper piping be used for at least three feet before and after the heater (follow local codes if more stringent). Keep water inlet pipe to no less than 1/2 inch diameter to allow the full flow capacity. Remember that water pressure must be sufficient to activate the heater when drawing hot water from the top floor. If the hot and cold connections to the heater are reversed, the heater will not function. The AquaStar 125B is provided with one flexible type connector that must be connected to the inlet fitting of the water valve as shown in Fig 5. 1/2" Copper or brass fittings work best when connected to the connectors. See Fig 6. The flexible type connector seals to the water valve by means of a union connection with a washer type gasket at the joint. No pipe dope or thread tape is to be used at this joint. No pipe dope or thread tape is to be used at these joints. Be certain there are no loose particles or dirt in the piping. Blow out or flush the lines before connecting to the AquaStar. Full port valves should be installed on both the cold water feed line and the hot water outlet line to facilitate servicing the heater. For installation on a private well system, be sure that the **water pressure** is set between 30 and 50 psi.

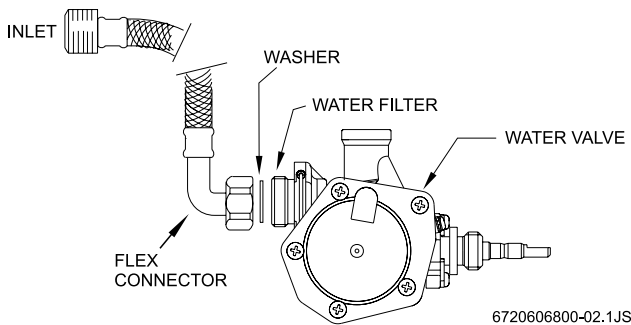

**Fig. 5 - Water valve and water connector, top view**

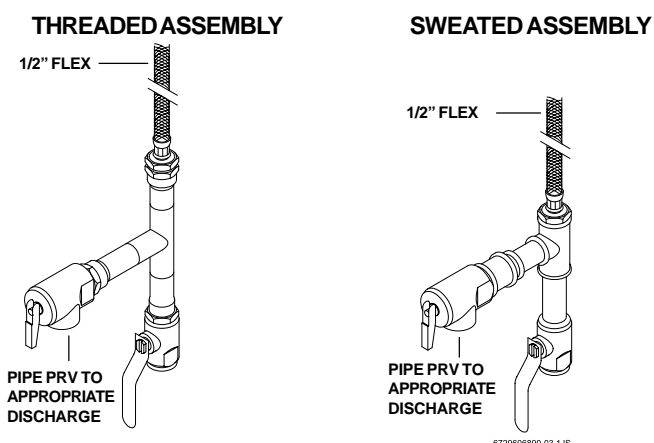

**Fig. 6 - Plumbing connections for the AquaStar 125B**

### Connecting the pressure relief valve (PRV)

A listed pressure relief valve supplied with the heater must be installed at the time of installation. No valve is to be placed between the PRV and the heater. No reducing coupling or other restriction may be installed in the discharge line. The discharge line must be installed such that it allows complete drainage of both the PRV and the line. The location of the PRV must be readily accessible for servicing or

replacement, and be mounted as close to the water heater as possible. See Fig 7.

To install the PRV, a suitable fitting connected to an extension on a "T" fitting can be sweated to the hot water line.

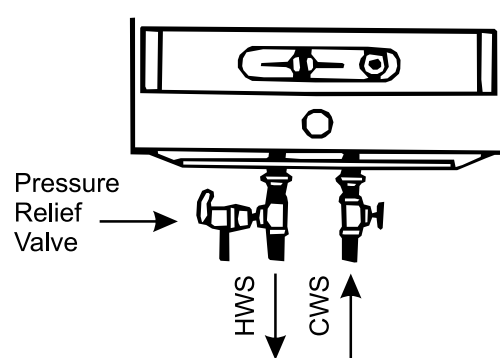

**Fig. 7 - Pressure Relief Valve**

## OPERATING INSTRUCTIONS

Before proceeding with the operation of the heater make sure that the system is filled with water.

Open the cold water inlet supply to the heater fully.

Open a hot water faucet to permit the water to fill the heater and the piping and to eliminate the air trapped in the system. Close the hot water faucet after the water flows freely and all the air has escaped from the system. The water heater is now ready to operate.

## FOR YOUR SAFETY READ BEFORE LIGHTING THE PILOT

**Warning:** If you do not follow these instructions exactly, a fire or explosion may result causing property damage, personal injury or loss of life.

**A.** This appliance has a piezo-igniter for lighting the pilot burner. When lighting the pilot, follow these instructions exactly.

**B.** BEFORE LIGHTING smell all around the appliance area for gas. Be sure to smell next to the floor because some gas is heavier than air and will settle on the floor.

### WHAT TO DO IF YOU SMELL GAS

- Do not try to light any appliance.
- Do not touch any electric switch; do not use any phone in your building
- Immediately call your gas supplier from a neighbor's phone. Follow the gas supplier's instructions.
- If you cannot reach your gas supplier, call the fire department.

**C.** Use only your hand to push in or turn the gas control buttons. Never use tools. If a button will not push in, check to make sure the buttons are being pushed in the proper sequence. Follow these instructions exactly. If control button(s) are jammed, close the gas supply and call a qualified service technician. Attempted forceful repair may result in a fire or explosion.

**D.** Do not use this appliance if any part has been under water. Immediately call a qualified service technician to inspect the appliance and to replace any part of the control system and any gas control which has been under water.

## LIGHTING INSTRUCTIONS (as seen on front cover of heater)

1. STOP! Read the safety information above on this plate.
2. The Gas valve must be turned off by sliding the gas valve button to the far left under the OFF (●) mark.
3. Wait five (5) minutes to clear out any gas. If you smell gas, STOP! Follow "B" in the safety information above on this plate. If you don't smell gas, go to next step.
4. The pilot burner is located behind the peephole in the front center of the jacket directly below this instruction plate.
5. Slide the gas valve button to the right, under the pilot mark (⚡).
6. Fully depress gas valve button and light pilot by pushing "PILOT IGNITER" button (⚡). This step may have to be repeated.
7. Observe the pilot flame through the peephole. The gas valve button should be held down at least 15 seconds with pilot burning. When the gas valve button is released, the pilot should continue to burn.

- If the gas valve button does not pop up when released, stop and immediately call your service technician or gas supplier.
- If pilot does not stay lit, repeat steps 1 through 7.
- If pilot will not stay lit after several tries, slide the gas valve button to the left, under the OFF (●) mark and call service technician or gas supplier.

8. Once pilot remains lit, then slide the gas valve button to the right, under the ON mark (●●●). The heater will now fire when water is drawn at a rate greater than the threshold flow rate.

**NOTE:** If main burner should fail to ignite, make sure pilot is burning. If not, repeat lighting steps 1 through 7.

### TO TURN OFF GAS TO APPLIANCE

Slide the gas valve button to the far left, under the off (●) mark and close the gas supply to the heater.

### SETTING THE WATER TEMPERATURE

The AquaStar 125 B LP and 125 B NG water heaters have a gas control that modulates burner input in response to flow. Its purpose is to ensure that the hot water temperature will remain steady, although the water flow demand might vary (down to 1/2 gal/minute). To adjust the temperature on your AquaStar, turn on a hot water faucet to its maximum flow. At the water heater, turn the large knob located beneath the main gas controls on the front of the heater all the way to the right (clockwise). See Fig 8. This will produce a temperature rise of approximately 90°F at flow rates between 0.5 and 2.0 gallons per minute. Given that average incoming water temperatures are 50°F, this heater will produce approximately 140°F water at these flow rates. Turning the dial all the way to the left (counterclockwise) will produce a temperature rise of approximately 45°F for flow rates between 1.1 and 3.7 gallons per minute. It is safest to select a comfortable temperature and not have to mix in cold water.

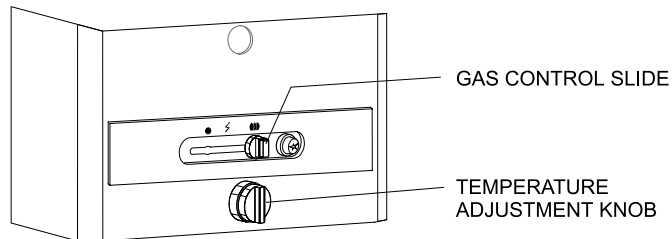

**Fig. 8 - Water Flow Control Knob**

The position you select on the temperature adjustment knob will depend on the temperature of the incoming water (50°F is average in the U.S.). In warm weather regions where the incoming cold water is generally warmer, or during the hot weather months in some other areas a midway setting on the temperature adjustment knob would produce a temperature rise of about 70°F, giving an output of approximately 120°F. At this setting, if it is still necessary, one could mix a small amount of cold water in a shower and have a comfortable shower at about 3 gallons/minute. During the colder months, or in cold climate areas, it might be necessary to set the control to the maximum position, all the way clockwise to the right.

Do not supply the AquaStar 125B with preheated water. For this type of application, purchase a solar model 125 B LPS or 125 B NGS.

## MAINTENANCE AND SERVICE

### **⚠️ REVIEW MAINTENANCE TABLE ON THE BACK OF THIS MANUAL**

Approximately once a year, the AquaStar should be checked and cleaned. To remove the front cover, first remove the incandescent particle tray, then pull off the temperature adjustment knob and unscrew and remove the plastic collar. Pull main cover out toward you and lift up and out. THE FOLLOWING OPERATIONS SHOULD BE PERFORMED BY A QUALIFIED SERVICE PERSON:

**Vent System:** Should be checked annually. Clean and repair as needed.

**Water Valve** (Part # 8707002649): The water valve on this heater should be serviced periodically. Lubricate component #23 on page 16 with a small amount of silicon, faucet or lithium grease every two years to keep its o rings fresh and pushrod sliding smoothly. Every 3-5 years replace component #23 on page 16. The frequency will depend on the mineral content of the water and conditions of use or whenever signs of corrosion appear at the gas and water valve joint. Periodically check that the water inlet filter (#25 on page 16) is clean as well.

**NOTE:** If water valve is removed, be sure to also inspect the o ring seal on the end of the right hand side water pipe before re-installing. Lubricating the o ring with lithium or faucet and valve grease is recommended.

**Pilot Flame:** The pilot flame should burn with a clean sharp blue flame and should resemble the diagram in Fig 9. If the flame is yellow, or if the pilot knob has to remain depressed for a long time in order to keep the pilot lighted, the pilot burner and or the pilot burner orifice may need to be cleaned,

the orifice may need to be replaced, and or the air screen may need cleaning. The pilot flame should envelop approximately 10 mm (3/8") of the tip of the thermocouple. If it is too small, the pilot burner must be cleaned. To obtain a spark, the position of the Piezo igniter electrode should be approximately 3 mm (1/8") from the pilot burner tip.

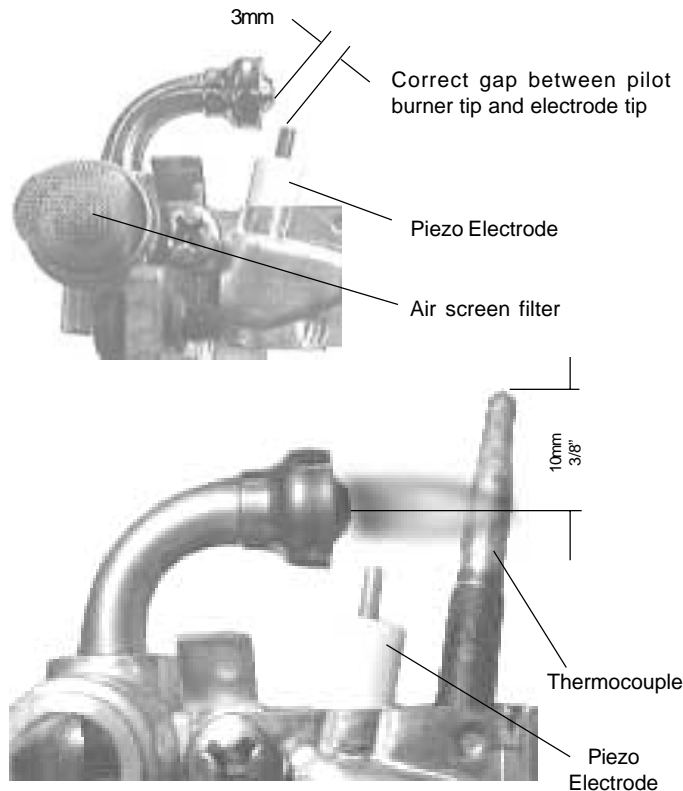

**Fig. 9 - Characteristic Pilot Flame**

**To clean the pilot burner and/ or the pilot orifice :** Turn off the gas at the unit. Remove the cover of the heater. To do so, pull off the temperature adjustment knob and unscrew and remove the plastic collar and unscrew the central screw located at the bottom of the front cover. Pull main cover out toward you and lift up and out . Pull the air screen off, wash it and blow any lint off (See Fig 10). The pilot orifices should also be cleaned or replaced. **Do not enlarge the orifice.** Do not use any wire or sharp object to clean orifices. Natural gas orifices are large enough that you can usually clean them by blowing through them. LP orifices, on the other hand, are too small to clean and should be replaced. See #3 in Trouble Shooting Section. To access the pilot orifice, remove 2 screws holding pilot assembly in place. Then loosen compression fittings to expose pilot orifice.

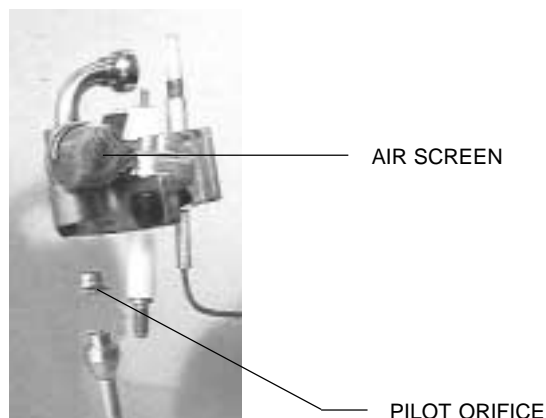

**Fig. 10 - Pilot burner with air screen/ pilot orifice**

**Main Burner Flames:** The main burner flames should be blue, with a more intense blue cone in the center core. Yellow flames could be a sign of wrong size gas orifices or dirty burners, or a blockage on the heat exchangers fins. If some burners have yellow flames while others have good flames, it is likely that dust, lint or spider webs have partially clogged the burner venturis. To clean the burners, contact a gas service person.

**Mineral Scale Build-up:** The AquaStar heater, when operated at lower temperatures settings, does not accumulate mineral build-up. If however, the heater is used at the higher temperature settings and the water has a high mineral content, periodic descaling may be necessary. The heating coils should be flushed with a descaling solution. Consult your dealer or Controlled Energy for instructions.

**TROUBLE SHOOTING** (see maintenance table)

**Introduction**

*The AquaStar 125B burners are activated by a water flow valve. Numerous water related problems can cause this water valve to malfunction such as: Insufficient water flow volume to activate the burners at its minimum flow requirement; Dirt in the water flow valve causing it to malfunction; Sediment build-up in faucet aerators, or shower heads; Uneven pressures between cold and hot. (with single lever faucets) Plumbing cross overs. These water flow related problems can cause the heater to deliver less than its full output, or to fail to ignite or to shut down completely.*

Problems are stated in upper case, bold face. Most common causes for the problems follow in order of likelihood. The suggested solutions require that the cover be taken off. To do this, remove incandescent particle tray, pull off the temperature adjustment knob and unscrew and remove the plastic collar and unscrew the central screw located at the bottom of the front cover. Pull main cover out toward you and lift up and out.

**PILOT LIGHT WILL NOT LIGHT**

**1. No gas to the AquaStar**

- A. Gas cock on gas line may not be open.
- B. Gas valve button has not been moved to "PILOT" position ( ⚡ ). Slide button to right to PILOT.
- C. Gas regulator may be shut or damaged.

**2. In-line AquaStar gas regulator jammed (usually on LP gas)**

Replace or unlock the regulator. **Note:** The regulator furnished with the heater is designed for low gas pressure. Excessive pressure will lock it up (propane only). Locking usually happens if the gas pressure between the gas tank (propane) and the water heater's gas regulator has not been reduced. See page 2 for recommended correct gas pressure. To unlock a regulator, consult your gas supplier.

**3. Pilot orifice clogged and/or air screen dirty, or pilot gas filter is dirty.**

Clogging of the pilot burner can be caused by dust and any suspended matter contained in the ambient air.

Although the filters can lengthen the cleaning intervals, they can never completely prevent such clogging. In consequence the gas jet issuing from the pilot orifice is reduced and or the air mixture is reduced. The pilot flame is weak and thus can no longer heat the thermocouple sufficiently. For cleaning purposes, the air filter screen is pulled off, washed and blown out. The pilot orifice has likewise to be cleaned or exchanged.

#### 4. Air in the Gas Line

**Note:** Normally this is a problem only at the time of initial installation, after the pipes have been worked on, or after a propane tank has been allowed to empty, or after the heater has been shut down for a long time.

Bleed all the air trapped in the gas line. Because of the very small pilot orifice (especially on LP gas models), bleeding out all the air could take several minutes. Slide the gas valve button to pilot position (⚡) and depress this button until all the air has escaped, and the gas has arrived. During this process, press repeatedly on the piezo ignition button until the pilot flame has ignited.

### PILOT LIGHTS BUT FLAME GOES OUT WHEN BUTTON IS RELEASED

#### 1. Pilot push button was not pushed in far enough or was not held in long enough

Once pilot flame has been lighted. Hold button pushed in for at least 15 seconds to give time for the pilot flame to properly heat the tip of the thermocouple.

#### 2. Pilot flame improperly aimed or is too weak so it is not properly heating the tip of the thermocouple.

The Pilot flame should be a sharp blue flame and aimed at the tip of the thermocouple so that it envelops 10 mm (3/8") of the thermocouple tip. Pilot flame has to be properly aimed at the thermocouple. See Fig 9.

#### 3. Poor thermocouple connection at the electromagnet

**Note:** Electromagnet is part #8707201012 located on the right side of the gas valve behind the piezo push-button assembly. Check the tightness of the thermocouple connection nut at the electromagnet: The Electro-magnet connection is a large aluminum 17mm hex head nut. The thermocouple end is a 5 mm brass nut which screws into the 17 mm nut. Tighten the thermocouple nut snugly but not too tight.

#### 4. Poor circuit connections at the ECO (overheat sensor) or the flue gas safety device

Oxidation or looseness of the terminal connections can result in millivolt current loss through the thermocouple safety circuit. Clean terminals with very fine sand paper or an eraser and reconnectx leads.

#### 5. Faulty ECO (part #8707206074)

If cleaning the terminals attached to the ECO did not fix the problem, connect a jumper wire between the two wires and try to relight the pilot. If the pilot flame now remains on, replace the ECO. If the flame still goes out when the button is released, the ECO is not defective. Go to next step.

#### 6. Faulty thermocouple (part #8707206074) or electromagnet ) Unless these 2 parts are at least 8 to 10 years old, it is very unlikely that they are faulty. Before testing, reconfirm that #2 is absolutely correct, and that all connections are clean and tight.

To test the thermocouple, disconnect the thermocouple lead at the ECO. Insert a multi-meter probe into the thermocouple lead and attach or hold the other lead at the metal gas valve (DC common). Light the pilot flame and hold button, meter reading should be 24 mVDC or more. If the reading is 24 mVDC or more the thermocouple is good. To test the electromagnet, re-connect the thermocouple lead to the ECO, light pilot and hold button while taking a reading between the ECO and flue gas sensor leads and the metal gas valve (DC common). The reading should drop to 19 mVDC or less. If it does not, replace the electromagnet.

### BURNERS DO NOT IGNITE WHEN HOT WATER IS TURNED ON

#### 1. Pilot is not on.

Light the pilot. See lighting instructions.

#### 2. Gas valve button not positioned on Burner Position

Be sure pilot flame is on. Slide gas valve control to burner position (🔥).

#### 3. Cold incoming water connection made to wrong side of heater

Make sure cold water inlet connection is on the right side of heater when you are facing heater.

#### 4. Water flow rate at hot water tap is too low.

**Note:** When the flow control is turned all the way clockwise, the AquaStar models 125B require 1/2 gallon per minute flow to activate the burners. This is a flow which would fill a quart jar in 30 seconds. If the flow control knob is turned fully counterclockwise, a flow rate of 1.1 gpm is required to activate the burners.

#### 5. Cold water inlet filter on heater is dirty.

Remove filter and clean. This screen filter is located at the inlet side of the water valve (fig. 12, #25). Check and clean faucet aerators too.

#### 6. Crossover in household plumbing

The AquaStar burner activates when there is sufficient water pressure drop in the AquaStar water valve assembly — i.e. when a hot water faucet is opened. If there is a crossover in the plumbing, the necessary pressure drop in the AquaStar will be insufficient, or totally eliminated. A plumbing crossover can be caused by a bad washer at a single lever faucet or incorrect plumbing or a mixing valve in the line, etc. which permits hot and cold water to mix in the plumbing. The crossover will create a back pressure in the system preventing the pressure drop in the Aquastar — i.e. cold water is entering the water heater from both sides and the burners will not come on. To confirm there is no crossover in the plumbing, shut off the cold water supply to the AquaStar. Open your hot water taps. There should not be any water flowing. If there is water flowing, there is a crossover in the plumbing. This is a plumbing problem, not an Aquastar problem. Please contact your plumber.

## 7. Water valve parts may be dirty or components damaged.

Water valve and component parts must be totally free of dirt. First check that the venturi is free of dirt particles. In hard water areas, mineral deposits can eventually (3 to 5 years in hard water areas) corrode the water valve parts to a point where they will need replacing. *Any sign of moisture or corrosion at the joint of the water valve and the gas valve is a sign that the water valve assembly components need to be serviced immediately.* **Note:** Water valve for model 125B is part# 8707002649 for both LP and NG models. (Contact service person to clean water valve or replace if corrosion is present).

## PILOT LIGHT GOES OUT DURING OR IMMEDIATELY AFTER HOT WATER HAS BEEN USED

### 1. Gas pressure too low

Very low gas pressure may be caused by low delivered gas pressure, a jammed gas regulator or undersized gas lines. If the gas lines are undersized, there may still be the specified static gas line pressure. However when the water valve opens, and gas enters the burners, the pressure could drop sharply, causing the pilot flame to go out. Have a gas technician confirm the gas pressure both static and at maximum Btu output. Specifications for your heater are on page 2.

### 2. Pilot may be dirty or weak

See Page 9 for instructions on pilot maintenance.

### 3. Burners are not shutting down immediately when hot water is turned off

**Note:** If burners don't shut down immediately when the hot water is turned off, the heater will overheat and the ECO will shut-off the gas. Rebuild the water valve assembly. Contact service person to clean or rebuild water valve.

### 4. ECO (overheat sensor) tripped due to overheating

Re-ignite the appliance 10 minutes later. If it happens again, contact your service person or Controlled Energy.

### 5. Flue gas safety device tripped

Ventilate the room and re-ignite the appliance 10 minutes later. If it happens again, contact your service person or Controlled Energy.

## WATER IS TOO HOT

### 1. Temperature Selection too high

Turn the temperature adjustment knob counter-clockwise (to the left) to lower the maximum water temperature.

**Note:** This will increase the activation flow rate.

### 2. Inlet water temperature is too high (as with solar preheated water)

**Note:** Only the AquaStar 125BS should be used if the inlet water is preheated.

### 3. Reduce inlet gas supply when inlet water temperature is very warm (60°-75°F).

## WATER IS NOT HOT ENOUGH

### 1. Temperature selection too low.

Change the setting. Turn the temperature adjustment knob clockwise (to the right).

**Note:** This will decrease the activation flow rate.

### 2. Btu input is too low due to insufficient gas pressure

***It is extremely important for a tankless instantaneous water heater to have the right size gas line to obtain the correct gas pressure***

See specifications on page 2. Unlike storage tank water heaters, the burners of a tankless water heater must be very powerful to heat water instantaneously since they do this only at the time hot water is actually being used. It is therefore imperative that the gas pressure requirement be met exactly. Insufficient gas pressure will directly affect the water temperature at the time of usage. See page 2 for correct gas pressure settings and page 13 for locations where gas pressures are taken.

### 3. Btu input is too low due to insufficient gas supply

Make sure your main gas line is fully opened. If using LP gas, be sure that the size of the propane tank is adequate to supply the required gas pressure.

### 4. Cold water is mixing with the hot water between the AquaStar and the outlet

Compare water temperature at outlet of the AquaStar (hold the AquaStar's outlet pipe with your hand) and at the tap. If these two are very different, check for mixing valve or plumbing crossover (see "MAIN BURNERS WILL NOT IGNITE..." paragraph #6). Where automatic "anti-scald" valves are required by code, lower the temperature setting on the AquaStar as much as possible and balance the pressure between cold and hot water after the AquaStar.

### 5. Parts in water valve are corroded so that the gas passage is not fully opening.

## **HOT WATER TEMPERATURE FLUCTUATES / UNIT DEACTIVATED**

### **1. Unbalanced pressure in waterlines**

The added restriction caused by the Aquastar in the hot water system can result in uneven pressures between the cold and the hot. In such cases when mixing cold water at the tap, the lower hot water pressure may be overpowered by a much higher cold water pressure, which may cause the Aquastar burners to shut down (deactivate). Make sure faucet aerators or shower heads are free of minerals. **Do not add any flow restrictor to the shower head.**

**Typically this deactivation symptom is a result of the hot water being too hot to use comfortably. Warm inlet water generally causes this. Lowering the control knob setting and/or reducing the inlet gas supply to the heater should correct this deactivation symptom.**

### **2. Cold water is mixing with the hot water between the AquaStar and the outlet**

See #6 under "Burners do Not Ignite When Hot Water Is Turned On".

### **3. Inlet water pressure is erratic due to inadequate supply water pressure or saturated pressure tank on well system**

Check the inlet water pressure. On a private well, raise minimum pressure setting to 30 psi. Confirm that the pressure tank is not water logged.

### **4. Gas pressure is too low**

See page 2 and 7 for correct specifications.

Fig. 11 - Diagram of AquaStar 125 B

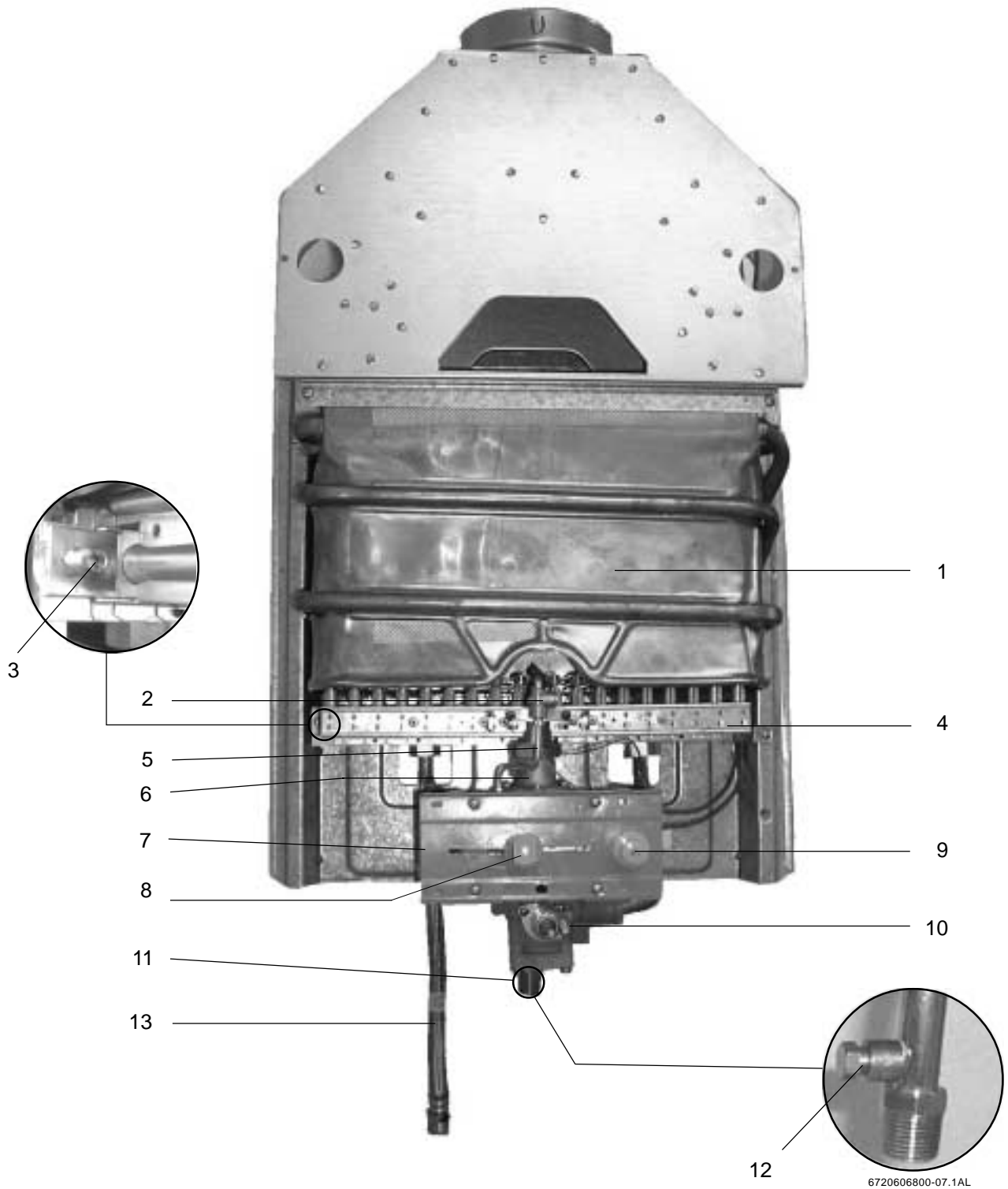

- |    |  |     |                                    |
|----|--|-----|------------------------------------|
| 1. | Heat exchanger                           | 8.  | Gas control slide                  |
| 2. | Pilot assembly                           | 9.  | Piezo igniter                      |
| 3. | Burner manifold gas pressure test nipple | 10. | Water valve                        |
| 4. | Main gas burner                          | 11. | Temperature adjustment selector    |
| 5. | Pilot gas tubing                         | 12. | Gas inlet gas pressure test nipple |
| 6. | Gas valve                                | 13. | Flexible hot outlet                |
| 7. | Pressure tap screw location              |     |                                    |

**Fig. 12 - INTERIOR COMPONENTS DIAGRAM AND PARTS LIST**

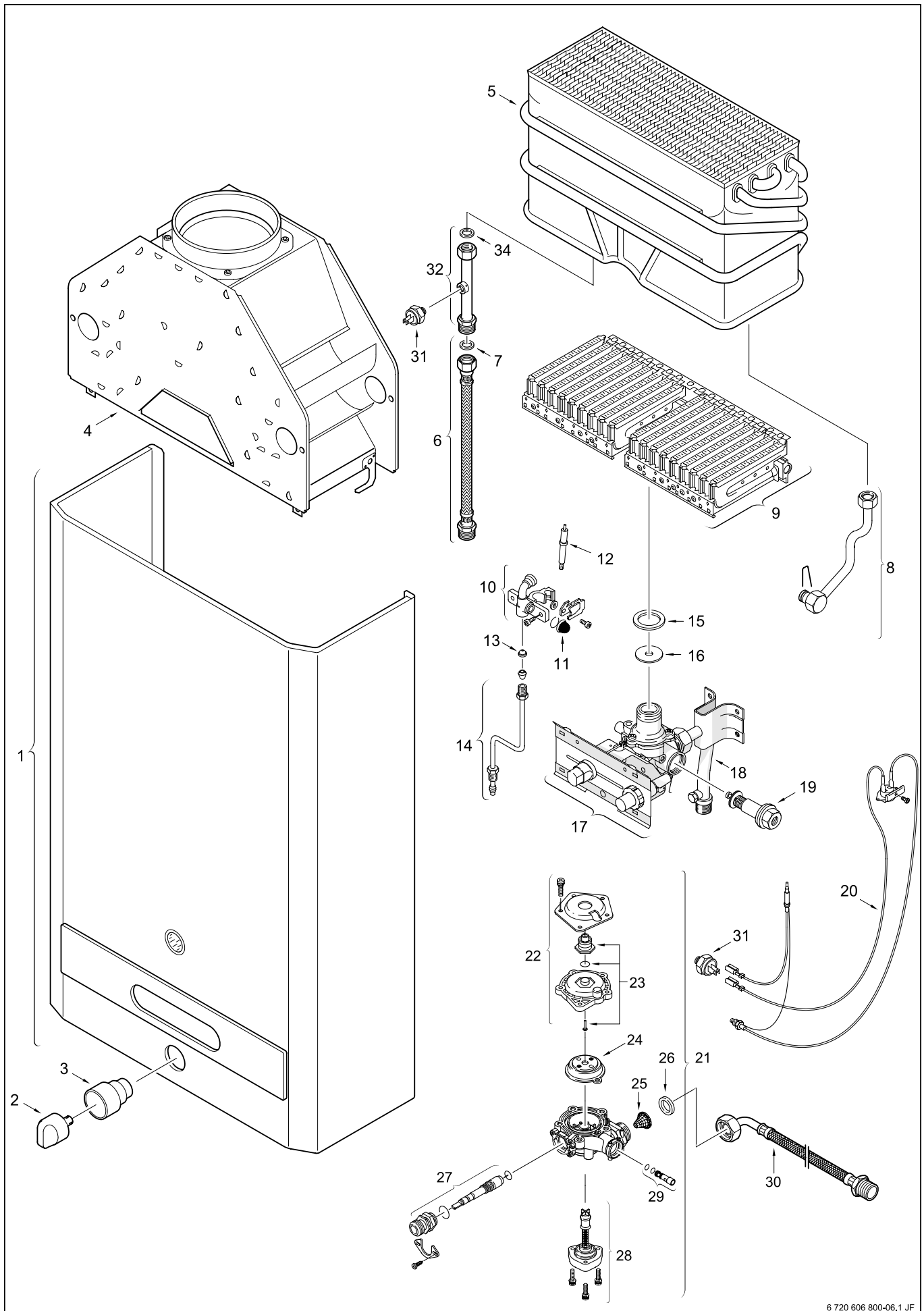

6 720 606 800-06.1 JF



Fig. 12

**INTERIOR COMPONENTS DIAGRAM  
AND PARTS LIST 125B**

1	Cover	8 705 421 025
2	Temperature adjustment knob	8 702 000 111
3	Temperature adjustment collar	8 700 403 008
4	Draft diverter	8 705 505 354
5	Heat exchanger	8 705 406 235
6	Outlet flex hose	8 700 703 130
7	Washer	8 700 103 658
8	Cold water pipe	8 700 705 627
9	Main burner	8 708 120 298 NG
9	Main burner	8 708 120 296 LP
10	Pilot burner	8 708 105 337
11	Pilot air screen	8 700 507 055
12	Piezo electrode	8 708 107 002
13	Pilot orifice	8 708 200 005 NG
13	Pilot orifice	8 748 200 173 LP
14	Pilot tube	8 700 707 320
15	Burner assembly washer	8 710 103 060
16	Throttle disc	8 700 100 174 LP
17	Gas valve	8 707 011 459 NG
17	Gas valve	8 707 011 463 LP
18	Gas supply pipe	8 700 705 552
19	Electromagnet	8 707 201 012
20	Thermocouple / Flue Gas Sensor	8 707 206 074
21	Water valve	8 707 002 649
22	Water valve cover	8 705 500 101
23	Sleeve	8 700 306 114
24	Diaphragm	8 700 503 053
25	Water inlet filter	8 700 507 001
26	Water connection gasket	8 710 103 043
27	Water valve selector screw	8 708 500 289
28	Volumetric water governor	8 705 705 009
29	Venturi	8 708 205 279
30	Water elbow fitting	8 700 703 114
31	Overheat sensor (ECO)	8 707 206 040
32	Connecting pipe hot	8 700 715 178
34	Washer	8 710 103 045



# INSTALLATION CHECKLIST

## GAS LINE SIZE

### Natural Gas

Nominal Iron Pipe Size*	1/2"	3/4"	1"	
MAXIMUM LENGTH	10'	40'	150'	

### Liquid Propane

Semi-rigid Tubing	1/2"	5/8"	3/4"	7/8"
MAXIMUM LENGTH	NOT RECOMMENDED	20'	60'	150'

\* Flex tubing greatly reduces capacity and, therefore, is not recommended.

## Minimum Vent Size\* and Height

Minimum Diameter	Minimum Height**
5 inches	6 feet**

\* **NOTE:** Vent size must not be restricted. Installation must comply with national fuel gas code venting requirements for a 117,000 Btu Category I appliance and any applicable local codes.

\*\* **NOTE:** Minimum vent height must be 6 feet, provided there are no elbows. Termination of the vent must be 2 feet above any obstruction within a 10 foot radius of vent pipe. Consult your gas utility or National Fuel Gas Code if vent will have elbows or share venting with another appliance. The vent connector should have as much vertical rise as possible (minimum 12") before any horizontal run.

## Water Pressure

For installation on well systems, insure that your water pressure is between 30 - 50 psi.

## MAINTENANCE TABLE see pages 10 & 11

	EVERY YEAR	EVERY 2 YEARS	EVERY 3-5 YEARS
LUBRICATE WATER VALVE		†	
REBUILD WATER VALVE			†
INSPECT WATER FILTER SCREEN	†		
INSPECT PILOT ASSEMBLY	†		
INSPECT VENT ASSEMBLY	†		
INSPECT MAIN BURNER	†		

Replacement Parts available from North American  
Distributor

### CONTROLLED ENERGY CORP.

340 Mad River Park  
Waitsfield, Vermont 05673  
Phone 800-642-3111  
Fax (802) 496-6924  
[www.controlledenergy.com](http://www.controlledenergy.com)  
[techsupport@controlledenergy.com](mailto:techsupport@controlledenergy.com)

**VULCANO Termodomésticos S.A.**  
Estrada de Cacia  
3801 - 856 Aveiro - PORTUGAL