Technical Standard

Gas Meter Location – Single and Multi Occupancy Premises

Document number	TS 4352
Issue number	15
Status	FINAL
Approver	Sam Pitruzzello
Date of approval	September 2018

Gas Meter Location – Single and Multi Occupancy Premises

Table of Contents

1	PURPOSE / SCOPE	3
2	RESOURCE REFERENCES	3
3	ABBREVIATIONS AND DEFINITIONS	3
4	SERVICE LINE ROUTE	4
5	METER LOCATION	4
5.1	PROHIBITED LOCATIONS	5
5.2	SPECIAL SITE CONSIDERATIONS	5
5.3	METER INDEX	6
6	METER ASSEMBLY CLEARANCES	7
7	METER PROTECTION	10
8	METER CABINETS, BOXES OR ALCOVE	10
9	DEFERMENT FROM THIS STANDARD	12
10	APPENDIX A	12
11	SCHEDULE OF REVISIONS	13

Gas Meter Location – Single and Multi Occupancy Premises

1 PURPOSE / SCOPE

This standard gives requirements for the location of gas meters, with a capacity not exceeding 65 Sm³/h, on single and multi-occupancy residential premises.

For gas meters with a capacity exceeding that covered by this standard for residential premises refer to Gas Networks, AusNet Services.

2 RESOURCE REFERENCES

Document ID	Document Title
GFP 1.2	Standard Procedure - General Information for Service Laying
GFP 4.6	Standard Procedure - Meter Refix - Relight Appliances
AS 60079	Explosive Atmospheres – Suite of Standards (Supersedes AS2430)
AS 5601	Gas Installations
AS 4645	Gas Distribution – Suite of Standards
AS 3000	Wiring Rules

3 ABBREVIATIONS AND DEFINITIONS

Term	Definition
ACCESSIBLE	Access can be gained without hazard or difficulty for inspections, repairs, renewal, upgrade or any operation purposes
FITTING LINE	A network of gas pipes after the meter. Always belonging to the customer, often-called "consumer piping"
GAS INSTALLATIONS	A combination of the following, used or intended to be used in supplying and utilisation of gas taken as separate items or as a whole: Fitting line, fittings, components, appliances, flues, sub-meters, meters, apparatus or other devices and associated requirements
GAS LOAD	Total gas consumption of all downstream appliances
METER CONSUMER BILLING METER	A meter that is used by the Retailer to bill the Consumer for gas usage
SERVICE	The pipe that runs between a pipeline or a main to the master meter
SHALL	'Shall' is used to indicate a provision as mandatory
SHOULD	'Should' is used to indicate a provision which is not mandatory but is recommended
VENTING	The process which allows a gas to be removed from the escaping point safely to the atmosphere
OPSO	Over Pressure shut-off.
LPG	Liquid Petroleum Gas
MULTI OCCUPANCY	Where a single occupancy block of land is subdivided to two or more units
METER ALCOVE	A dedicated metering space with one side open to atmosphere, which does not permit access by people.

Gas Meter Location – Single and Multi Occupancy Premises

4 SERVICE LINE ROUTE

The service line route shall be as specified in AusNet Services GFP 1.2.

5 METER LOCATION

The meter shall be located such that it is readily accessible and in a safe location that permits ease of reading, safe venting, maintenance and replacement. The nominated location should also ensure that the meter is external to any building. The preferred location is shown in Figure 1. Meter connections are subject to an Economic Feasibility Test based on agreement between all parties involved; negotiation should take place at the first gas supply request.

For single occupancy premises, individual meter placement should comply with Figure 1 below.

For dual or multiple occupancy premises all individual meters should be located at the front boundary of a property, (refer Figure 1 of this standard).

Generally for multi occupancy premises, ‘Other Authority’ meters such as water and electricity are located centrally along the front boundary, inside a purpose built brick pillar. Gas meters should be co-located with these utilities on the stipulation that the remainder of the requirements of this standard are met. Individual units will then be supplied by private gas fitting lines, similarly to electricity and water.

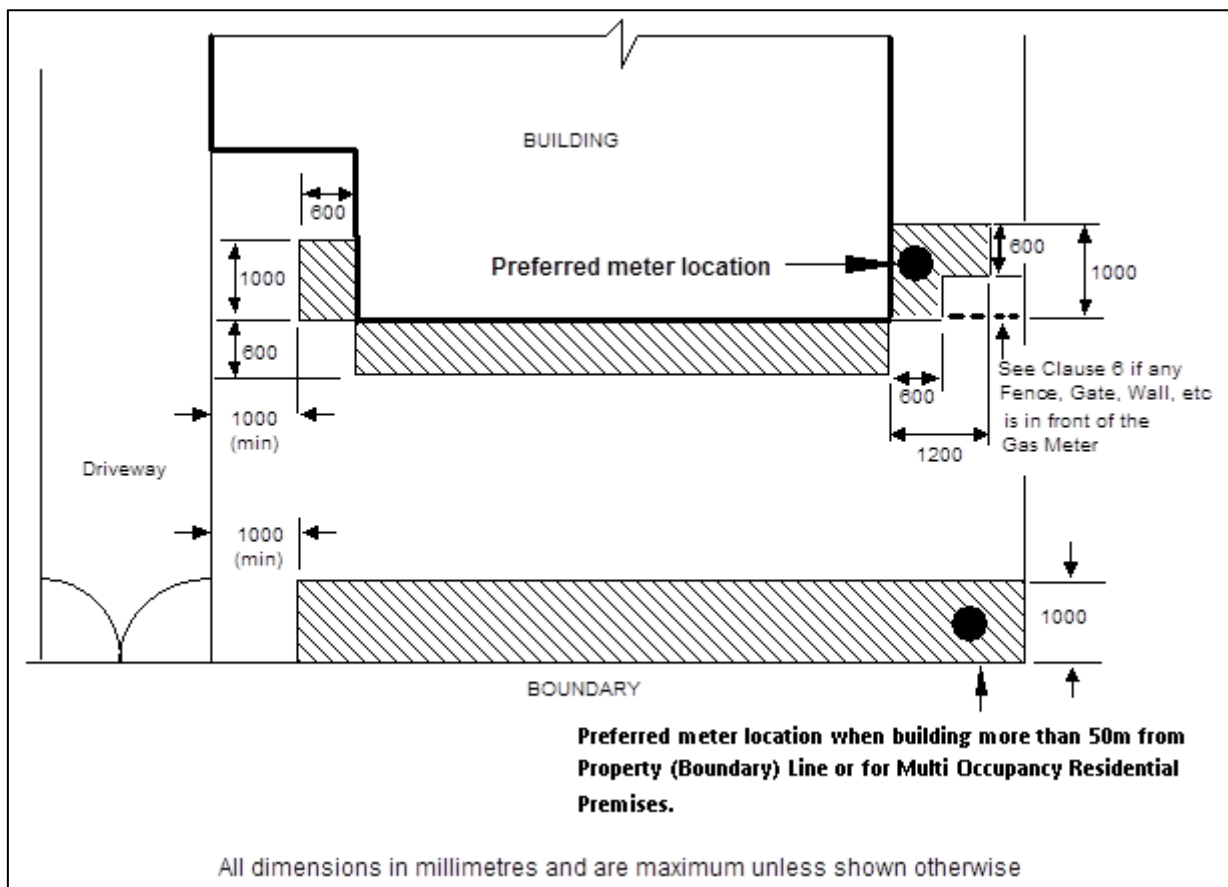

Figure 1 – Preferred meter location

Gas Meter Location – Single and Multi Occupancy Premises

5.1 PROHIBITED LOCATIONS

¹Meters are not to be installed in any of the following locations:

- a) A bedroom.
- b) A lift shaft or lift motor room.
- c) A room specifically intended for electrical switchgear.
- d) A fire-isolated stairway or passage.
- e) A fire hydrant duct or hose reel cabinet.
- f) Sprinkler or hydrant pump room.
- g) Near a source of ignition.
- h) In such a position that would obstruct egress from a building.
- i) In such a position where the meter would be subject to physical damage unless adequately protected.
- j) In an area where excessive temperatures or sudden excessive changes in temperature may occur.
- k) In the foundation area under a building.
- l) In a cavity wall, unless installed in a fully sealed ventilated enclosure.
- m) In a position where access for reading or maintenance is restricted.
- n) In an unventilated position.
- o) On the ground (directly).
- p) On a floor which is frequently wetted.
- q) On a floor which contains material which may corrode the meter.

5.2 SPECIAL SITE CONSIDERATIONS

All installations are to consider the following when selecting a site;

General

- Identification of possible sources of ignition.
- Avoidance of any location where meter may be subject to interference or vandalism
- Avoidance of any location where meter may be subject to vehicular damage
- Avoidance of any location where meter may prove to be a trip hazard
- Avoidance of any location where the meter may be subject to a natural hazard (bushfire, flood)
- Allowance for adequate ventilation
- Avoidance of any location beneath a habitable area including balconies (unless in a fire rated alcove or meter room)
- Avoidance of any location where escaping gas may become trapped i.e. below closed canopies where gas cannot disperse into the atmosphere

Alpine locations and LPG Installations

- For Alpine conditions and temperatures, consideration must be given to peak winter conditions when build-up of snow can occur.
- Due to the characteristics of LPG as a heavier than air gas, consideration for well ventilated installation is important.
- Reticulated LPG being heavier than air, the tendency is for the vaporised gas to migrate and pool should an escape occur is a critical consideration.

¹ Listing as per Appendix A of AS5601

Gas Meter Location – Single and Multi Occupancy Premises

- Consideration to snow drifts such as: Snow falls off roofs, stairways, balconies, or as a result of clearing operations from elevated decks and doorways. Also snow accumulation as a result of mechanical clearing operations of local access roads by heavy snow ploughing equipment.
- Accessibility all year round should also be a consideration and not be difficult due to sloping or unstable ground conditions. Preference needs to be given to necessitate meter – regulator installations are located above normal snow levels.

5.3 METER INDEX

Where a meter is to be located behind a barrier (fence, gate, wall), which will prevent access for index reading;

- the meter is to be located adjacent to the barrier;
- the barrier, if of closed construction, is to include provision for meter reading. Such provision shall be an opening directly in line with the meter index. The minimum dimensions of the opening are 100 mm x 100 mm; and
- Where the barrier is of open construction the meter index needs to be visible (to allow meter reading) from the accessible side of the barrier.
- The gas meter enclosure shall be kept unlocked at all times, if a meter index window is not provided
- Gas meters located inside pillars, walls, compartments, cavities and special boxes shall have dial index at 45 degrees or vertical. A horizontal dial shall not be used in these instances.

Gas Meter Location – Single and Multi Occupancy Premises

6 ²METER ASSEMBLY CLEARANCES

The gas meter and/or associated assembly (e.g. regulator, relief valve) shall have the following minimum clearances:

From the centreline of the vent / then arcing from the regulator vent:

- a) 1000mm from any door, openable window, natural ventilation point or any other opening into the building or enclosed space (excluding sub-floor ventilation openings). Refer Figure 2 for reference point measurements.
- b) 1000mm from a source of ignition or a flue terminal.
- c) 1000mm from electrical equipment other than permitted in (d).
- d) 500mm below an electricity meter box, refer Figure 3.
- e) 500mm from communication equipment. I.e. Telstra, Optus, Foxtel or NBN Co cable junction boxes. (Refer Figure 4 and 5 below).
- f) 500mm from earth stakes
- g) The distance to any building opening and the relief venting device of a gas installation shall be no less than 1000mm.
- h) 3000mm from mechanical air inlet (Note that the outdoor component of an air conditioner is not a mechanical air inlet. These shall comply with the clearance stated in item b))
- i) 5000mm to any flammable materials storage area without approved protection against spillage and leakage

From any part of the meter assembly (i.e. meter outlet):

- j) 250mm from a source of ignition, electrical equipment or a flue terminal. (In addition to requirement b and c, for AL1000 installations)
- k) 1000mm from a driveway or vehicle access at the time the meter was first installed. Refer figure 1. Note: if changes to vehicle access are made post the installation of the meter an assessment on vehicle impact cannot be made.
- l) 100mm between the meter base and the finished ground level (no other infrastructure is permitted between the meter base and finished ground).
- m) 100mm from storm water downpipes (meter is not to be placed in front of downpipes). Measured from inlet riser or meter outlet connection.

Other:

- n) The distance between vent outlets of a single meter gas compartment and electrical equipment shall be a minimum of 1000mm. For multiple meter compartments refer section 8.
- o) The co-location of gas and water meters inside a compartment or in proximity to each other is allowed. A minimum clearance of 150mm shall be kept between any component of the gas and water installations.

² Clause ZA 6.3.2 of the AS 60079.10.1 Explosive Atmosphere standard contains guidance that gas distribution equipment, by design, does not produce a hazardous atmosphere. Appendix K of the AS 4645 Gas Distribution Networks standard, also only references the hazardous area codes for regulators featuring a vent size greater than 50mm. As such, the clearances in this section are not solely based on hazardous area clearances, but also for maintenance and access purposes.

Gas Meter Location – Single and Multi Occupancy Premises

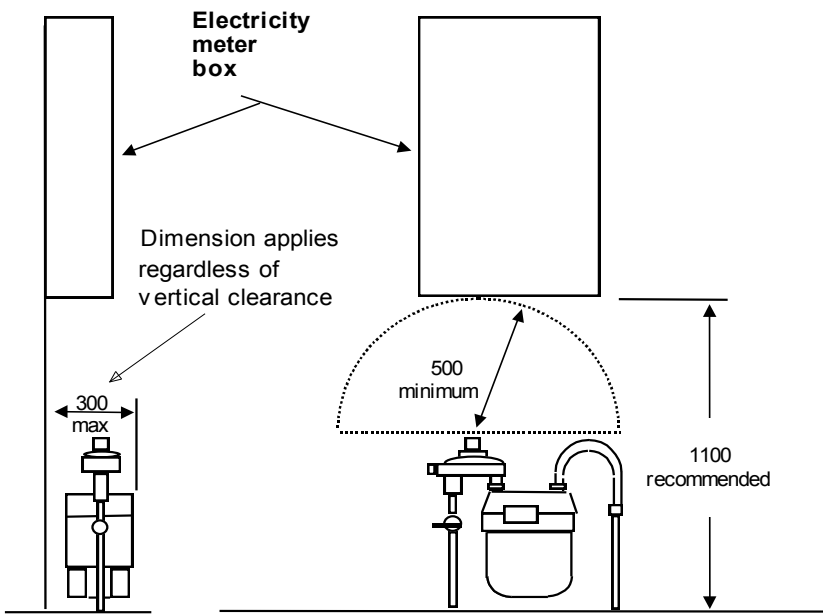

Notes:

1. The minimum clearance between any part of the electricity meter box and the gas meter regulator shall be 500 mm.
2. Refer to AS 2430.3 'Classification of Hazardous Areas – Specific Occupancies' where the diameter of the regulator relief valve opening exceeds 50 mm.
3. Gas meters which protrude more than 300 mm from the wall shall not be installed below the electricity meter box.

Figure 3 – Clearance to electrical meter box.

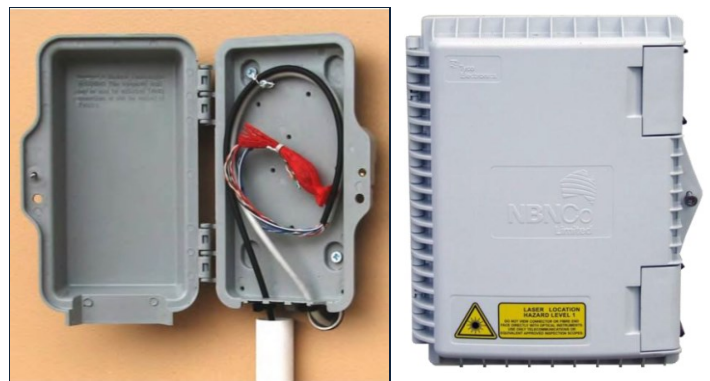

Figure 4: Telstra and NBN Co Junction Box

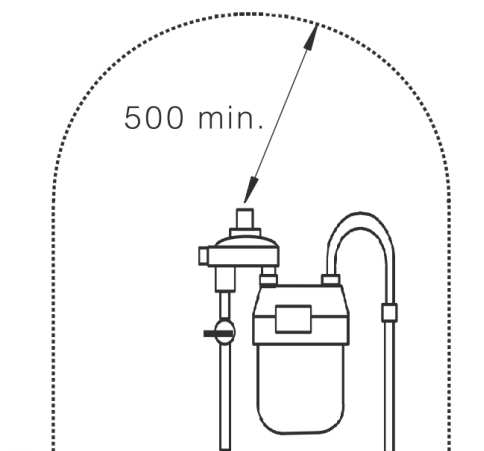

Figure 5: Cable Junction Box Exclusion Area

Gas Meter Location – Single and Multi Occupancy Premises

7 METER PROTECTION

Where a gas meter will be exposed to physical damage, corrosion, flooding, snow falls and snow conditions and snow clearing mechanical equipment or extreme winter conditions, protection approved by Gas Networks, AusNet Services shall be provided or a more suitable location selected.

Protection may include approved meter cabinets, bollards (refer drawing S91-5001-0), meter boxes (refer drawing S85-5000-1 for approved alpine wall mounted meter box), or approved cages.

In addition to instances where bollard protection is required for protecting vehicle movement within the immediate vicinity, bollard protection is also required where unobstructed vehicle movement is likely to occur within 1m of the gas meter location external to the title boundary. This protection must be in place prior to meter installation.

8 METER CABINETS, BOXES OR ALCOVES

A cabinet, box or alcove protecting a gas meter installation is referred to as a gas meter enclosure. Consideration must be given to those installations such that:

- The gas equipment shall be installed in accordance with AS 5601.
- The gas meter enclosure shall have ventilation openings as per AS 5601.
- The gas regulator shall either be a non-venting/internal venting, type having an over-pressure shut-off device (OPSO) or the outlet vented in accordance with AS 5601.
- The meter enclosure shall be installed external to the building and exposed to the atmosphere.
- Placement of the gas meter enclosure shall allow direct vertical unhindered access to a soil depth of 600mm directly below the enclosure in order to ensure ease of service riser installation. Unpaved ground access below the cabinet position is desirable at the time of installation – If paved, gas service should be sleeved.
- Any penetration to the gas meter enclosure shall be sealed to prevent any gas leakage to other cavities.
- The gas service riser must be electrically insulated from the gas main.
- A 4mm insulated earth wire shall be provided for the bonding of the gas inlet and outlet pipe to the metal gas meter enclosure.
- Gas meters shall not be co-located with electricity meters in combined meter enclosures. Gas meters can however be located in a single gas meter enclosure. This prevents later instances of electrical conduits being run through gas meter enclosures to electricity meters and switchboards above. It also ensures less likelihood of penetration to the gas meter enclosure which may result in gas ingress to cavity walls in the event of a leak.
- For gas meter enclosure locations inside walls, alcoves, pillars, boxes, front wall compartments walls of those cavities have to be made of fire rated material (2hr) and have to be gas tight, only specific perforation in front cavities doors are allowed for direct venting to outside
- Vent outlets of multiple meter cavities, multiple meter cabinets or multiple meter cupboards (usually via the perforated door) have to be a minimum of 1.0m away horizontally from any building opening and:

Gas Meter Location – Single and Multi Occupancy Premises

- A minimum of 5.0m distance to a power operated air intake
- A minimum of 3.0m away vertically from any opening to building
- A minimum of 3.0m away vertically and horizontally from any electrical substation opening
- Vent outlets of single meter alcoves, cabinets or cupboards that have a total connected capacity of <math><65 \text{ sm}^3/\text{hr}</math> (1,440 MJ/hr) shall comply with clearance requirements as indicated in section 6.
- Gas service entry to such enclosures with the exception of, cavities or boxes located in the outer walls of a building, can enter directly from the floor of such enclosures and without a sleeve.
- Gas service entry to a gas meter enclosure built into the wall of a building has to be provided in such a way that the service is never located under the building foundations, unless it is inside a sleeved conduit, which is separately vented to an external outside location.
- Multiple gas meters can be enclosed within a cavity up to and including an AL1000. Any meters with bypasses, or meters larger than an AL1000, need to be referred to Gas Engineering Services for consideration and approval.
- If due to any reason electrical lighting is to be provided to the gas meter enclosure, it shall be of a type that meets the requirements of the AS 3000 wiring rules and the referred AS 60079 Explosive Atmosphere suite of standards. It shall be suitable for a Zone 2 Hazardous Area, Gas Group IIA, Temperature Class T1 environment. A Class H electrical inspector certificate shall be provided to state as such before commissioning of the meter.
- Alcoves shall be limited to 750mm deep.
- Installations within alcoves are to be signed with a “warning restricted area” sign and be locked via a S43 key (warning sign SPAN 0006).
- For any installation within a gas enclosure Builder/Owner manager to provide certification ensuring the installation is 2 hour fire rated.
- No lighting or electrical devices are to be installed within the enclosure.
- The following minimum free space allocation shall be utilised as a guideline for each gas meter enclosure installation:

Installation Type	Required Height	Required Width	Required Depth
Residential meter installations – UG10, 610, 750 etc.	700mm *	600mm	350mm
AL425 meter installations	1,000mm *	1,000mm	600mm
AL425 meter installation with by-pass	1,500mm	1,000mm	600mm
AL1000 meter installations	1,000mm	1,000mm	600mm
AL1000 meter installation with by-pass	1,500mm	1,000mm	600mm

*For removable cabinets the required height for residential and AL425 installations may be 600mm.

NOTE: For the installation of any enclosure for a Gas Meter (combined with other utilities or standalone), must meet all of the above criteria and most importantly, prior signed approval

Gas Meter Location – Single and Multi Occupancy Premises

obtained from Gas Networks, AusNet Services from intending clients/developers etc., by submission of proposal drawings and locations in accordance with this Standard, AS/NZS 4645.1 and AS 5601.

9 DEFERMENT FROM THIS STANDARD

Any deferment from requirements specified in this standard shall be referred to Gas Engineering Services - AusNet Services for approval.

10 APPENDIX A

Meter positions identified during the meter replacement programs or any maintenance activities completed on meter units that are non-compliant with the clearances outlined in section 6 can be rectified if an approved OPSO type regulator is installed and the meter location clearance distances listed below are achieved.

This appendix can also apply to meter positions not complying with Section 6, identified during mains renewal projects, however approval must be first be sought from the relevant AusNet Services Project Manager on a per site basis.

This appendix **shall not** be applied to:

- New metering installations (e.g. new connection)
- Meter Alter Positions (Customer or Company initiated)

Allowable Metering Clearances with OPSO Regulator		
a)	Distance from door, openable window, natural ventilation, or any other openings into a building or enclosed space	400mm
b)	Distance from source of ignition or a flue terminal	500mm
c)	Distance from electrical equipment other than permitted in (d)	500mm
d)	Distance below an electricity meter box	500mm**
e)	Distance from communication equipment i.e. Telstra, Optus, Foxtel or NBN cable junction box	100mm
f)	Distance from earth stakes	100mm
g)	Distance to any building opening and the relief venting device of the gas installation	400mm
h)	Distance from mechanical air inlet	3000mm**
i)	Distance to any flammable materials storage area without approved protection against spillage or leakage	5000mm**

Notes:

** Marks clearances that remain unchanged from Section 6.

All other conditions outlined in Section 5 of this standard shall be complied with.

Gas Meter Location – Single and Multi Occupancy Premises

11 SCHEDULE OF REVISIONS

Issue	Date	Author	Details of Change
6	18/1/2006		Reference to TXU Networks replaced with SP AusNet. Reference to AG601 deleted. Reference to TS 4353 and TS 4354 deleted. Appendix 1 deleted and Appendix 2 renamed to Appendix A.
7	25/08/2008		Include clearance requirements from stormwater downpipes and earth stakes. Included referral to GNAE for one off items where clearance cannot be met.
8	09/10/2008		Minor amendments to clearance (improved clarity of measurement references)
9	06/05/2009		Changes referring to multi occupancy residential premises as well as referring to gas meter location inside special compartments, front walls, boxes, pillars and cavities. Amendment to clearance requirements for water meters.
10	22/03/2012	Anthony Bonacci	Includes clearance requirements for Telstra Junction Boxes, and attachment of junction box image.
11	Jan 2013	Anthony Bonacci	Revised requirements for communication equipment. (Including Telstra Junction Boxes).
12	May 2013	Anthony Bonacci	Correction of natural ventilation / mechanical ventilation clearances.
13	Sep 2014	Anthony Bonacci	Addition of canopy and habitable area clause in Section 5.1. Revised earth stake clearance from 300mm to 500mm to be in line with AS3000. Additional of specific electrical requirements in Section 8. Revised alcove size to be consistent with slab size. Clarified Section 6 clearances and measurement datum. Addition of old AS5601 restricted areas. Change to AusNet Services Template
14	Dec 2017	Mark Annetts	Inclusion of Appendix A which provides concessions to the meter location clearance distances if an approved OPSO type regulator is used. Additions to alcove requirements, including meters with bypasses.
15	Sept 2018	Sam Pitruzzello	Removal of word Residential from title Changes to wording regarding vehicle access Inclusion of the requirement of the following for gas meter enclosures <ol style="list-style-type: none"> 1. Signage 2. Builder certification

NOTE: This standard is duplicated on AusNet Service's website. Please ensure it is updated whenever new revisions to this document are published.