

SmartChoice

CLICK ANYWHERE on THIS PAGE
to RETURN TO AQUA SYSTEMS
WATER SOFTENERS at
InspectApedia.com

Water Conditioning System



Installation, Operation, and Maintenance Manual

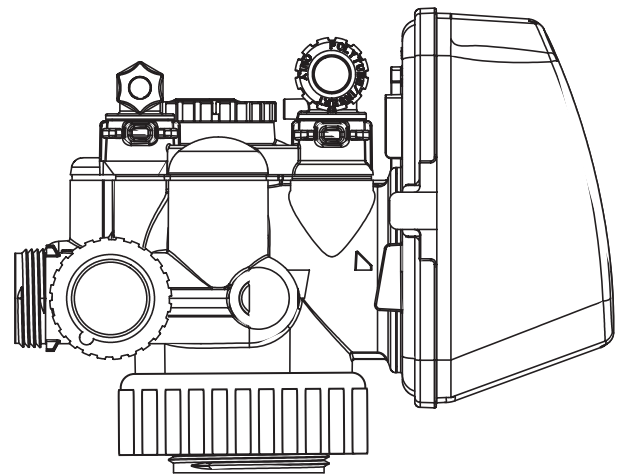

AQUA
SYSTEMS

7785 East US Hwy 36
Avon, IN 46123
(317) 272-3000 • (800) 447-5582
© 2002 New Aqua LLC

Introduction

Welcome to the Aqua Systems family of customers. We thank you for placing your confidence in Aqua Systems to assist with your water improvement project. Our goal is to provide water quality solutions with lasting performance. We are here to ensure the continued successful operation of your water treatment system, and we want to hear from you anytime you need assistance.

The SmartChoice water conditioning system was designed with the owner in mind. Most water conditioning products on the market today are designed to be disposable. The SmartChoice was designed to be a lasting appliance that can provide a lifetime of operation. The Exchangeable Component Maintenance System allows easy and efficient maintenance solutions. Each major part of the SmartChoice is a replaceable component that is easily removed. Although it may be years before the first service is required, this system offers you the ultimate in long-term care. All components of the SmartChoice are exchangeable with the factory. You have the option of exchanging the component yourself, or having an experienced service technician assist in maintenance. With either choice, the exchangeable component program ensures precise results and low cost.

Each SmartChoice is hand crafted by a skilled technician. The personal attention to detail assures you of the high quality craftsmanship Aqua Systems is known for. The SmartChoice is the solution for many common applications. It is also ideal for customized, built-to-suit requirements. The SmartChoice can be tailored as a solution to most any application. Please be sure you let your dealer know if you have any special circumstances, or if you observe anything unusual about the water supply you are installing the system on.

Please review this Installation, Operation, and Maintenance manual for valuable information that will help ensure successful results. Supplement manuals are available for specialized filters and custom tailored systems. Service manuals are also accessible on our web site at any time. If you have questions, please feel free to contact the factory or your local dealer. Aqua Systems and our professional dealers are always prepared to assist you.

Visit us on the web at www.aquasystemsonline.com

Owner Information

Owner Name _____ Serial Number _____

Date of Installation _____ Dealer Name _____

Model Number _____ Installer Name _____

Table of Contents

Owner Information	2
Introduction	2
How the SmartChoice Works	4
Pre Install Review	6
Requirements for Proper Operation:	6
Location Data	6
Pre Assembly	7
Bypass Operation	8
Installation	9
Softener Placement	9
Brine System Placement	10
Start Up	12
Disinfection:	12
Programming	12
Installer Displays/Settings:	14
User Displays/Settings:	15
Service	16
Parts Diagrams	19-30
Service Guide	31
Drive Assembly	31
Drive Cap Assembly, Main Piston and Regenerant Piston	32
Spacer Stack Assembly	33
Injector Cap, Screen, Injector Plug and Injector	34
Refill Flow Control Assembly or Refill Port Plug	34
Water Meter or Meter Plug	35
Bypass Valve	35
Troubleshooting	37
Troubleshooting	38

How the SmartChoice Works

Conventional System Design: HE & LC Models

The performance of a water softener is dependent on two key functions; a resin bed that cleans the water and precision equipment that cleans the resin. The two most significant elements that differentiate one softener from another is the volume of resin and the type of control valve.

The Resin Tank: contains media called resin. The resin attracts and collects minerals from hard water. Once the resin is saturated with hardness minerals it must be cleaned and regenerated. Once regenerated, the resin is ready to soften more water.

Resin tanks can be exposed or covered with a jacket or insulated cabinet.

Historically, resin tank construction was metal. To eliminate destructive corrosion, modern tanks are made with a molded liner that is wrapped in fiberglass for exceptional strength and durability.

Resin is made of cross-linked polystyrene to provide a long life of softening capacity.

The riser distributor collects the water that has been softened in the service cycle and routes it to the outlet of the control valve. It also aids in lifting and "fluffing" the resin bed for the brining cycle.

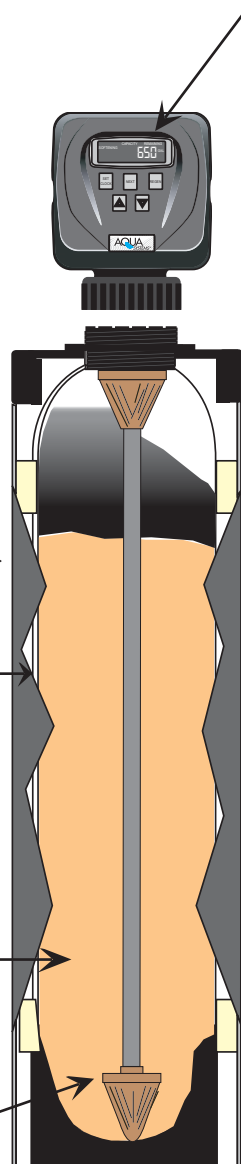

The Control Valve: routes the water flow through the system and controls the operating cycles. Hard water passes through the resin bed to become soft. During regeneration, water flow is reversed to backwash which cleans the resin bed. Brine is pulled in and then rinsed out to regenerate the resin, preparing it to soften more water. The brine tank is then refilled with fresh water for future cycles.

Regeneration cycles are based on digital logic, calculating daily water use and then scheduling a cycle at the preset time. Cycles can also be predetermined and programmed in the control if so desired.

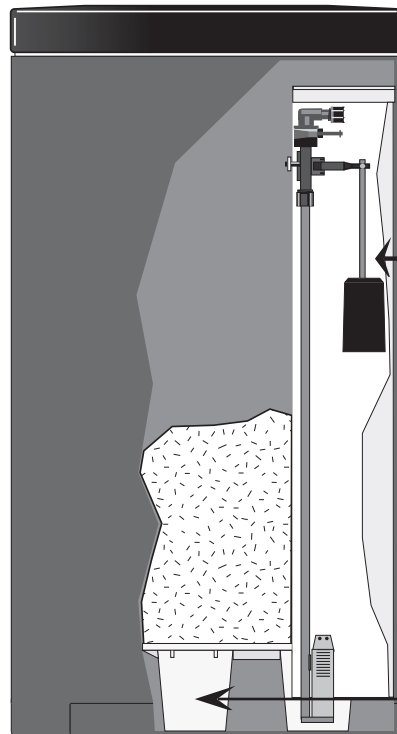

Brine tanks are available in a variety of sizes to fit in almost any space and are blow molded for strength and durability.

Safety shut off provides total brine system shut down to protect against brine overflow.

Salt shelf permits use of almost any type of salt and eliminates bridging and mush by keeping the salt dry.

The Brine System: stores salt and water to make brine which is used for regenerating the resin. Resin can be regenerated with sodium from sodium chloride (softener salt) or potassium from potassium chloride.

How the SmartChoice Works

Resin Scrubber “Turbo” Design: TB Models

The performance of a water softener is dependent on two key functions; a resin bed that cleans the water and precision equipment that cleans the resin. The three most significant elements that differentiate one softener from another are the volume of resin, the type of control valve, and the backwash system.

The Resin Tank: contains media called resin. The resin attracts and collects minerals and iron from hard water. Once the resin is saturated with hardness and iron minerals it must be cleaned and regenerated. Once regenerated, the resin is ready to soften more water.

Resin tanks can be exposed or covered with a jacket or insulated cabinet.

Historically, resin tank construction was metal. To eliminate destructive corrosion, modern tanks are made with a molded liner that is wrapped in fiberglass for exceptional strength and durability.

Resin is made of cross-linked polystyrene to provide a long life of softening capacity.

The “resin scrubber” turbulator distributor, unlike conventional distributors, turns the entire bed over several times during regeneration more effectively cleaning the resin.

The Control Valve: routes the water flow through the system and controls the operating cycles. Hard water passes through the resin bed to become soft. During regeneration, water flow is reversed to backwash which scrubs the resin bed. Brine is pulled in and then rinsed out to regenerate the resin, preparing it to soften more water. The brine tank is then refilled with soft, fresh water for future cycles.

Regeneration cycles are based on digital logic, calculating daily water use and then scheduling a cycle at the preset time. Cycles can also be predetermined and programmed in the control if so desired. Also, in problem waters, the control is programmed to backwash the resin twice resulting in increased iron removal.

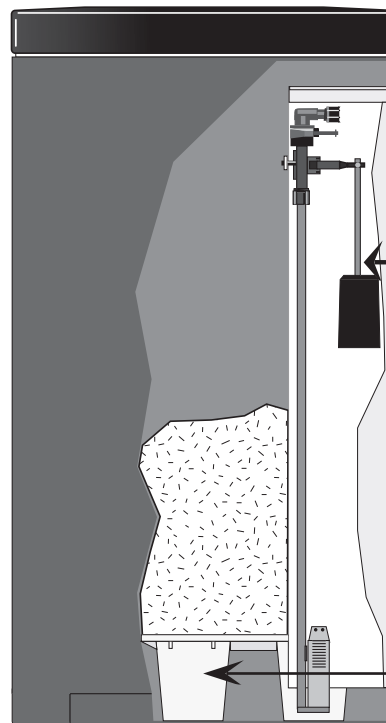
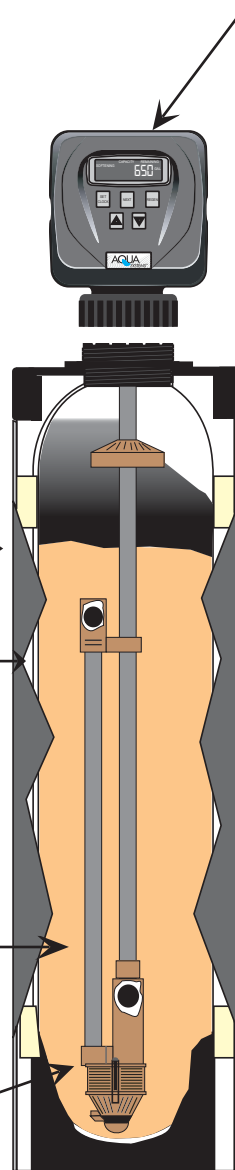

Brine tanks are available in a variety of sizes to fit in almost any space and are blow molded for strength and durability.

Safety shut off provides total brine system shut down to protect against brine overflow.

Salt shelf permits use of almost any type of salt and eliminates bridging and mush by keeping the salt dry.

The Brine System: stores salt and water to make brine which is used for regenerating the resin. Resin can be regenerated with sodium from sodium chloride (softener salt) or potassium from potassium chloride.

Pre Install Review

Requirements for Proper Operation:

Water Pressure: The system will operate on a minimum of 20 psi and a maximum of 125 psi.

Flow Rate: A minimum of 5 gallons per minute is required for proper system operation. If less than 5 gpm is available, consult with your dealer for custom settings or configurations.

Water Temperature: The range of water temperature to operate this system on is 40° F to 110° F

Drain: A drain should be within 20' of the system using 1/2" tubing. Over 20' should be 3/4" tubing. Maximum overhead height is 8'. Consult your dealer for any drain over 30'

Electricity: An uninterrupted 110 volt A.C. source is required to operate this system. *Note: Make sure electrical source is not on a timer or a switch.*

Tips:

Salt: Using a clean grade of salt will help eliminate the the need to clean out the brine tank. If the water supply contains iron, the use of an iron inhibiting salt can help the water quality. Ask your dealer for the recommended salt for your system.

Bypass: When installing a water conditioner, it is required that the system have a bypass in place to be able to shut off the conditioner without turning off the water supply.

Freezing: The water conditioner and the drain line must be protected from freezing temperatures.

Sand: If sand or sediment is present in the water supply, a sediment filter should be installed ahead of the system.

Location Data

Sizing Information:

Hardness _____ gr./gal.

Iron _____ ppm

pH _____

Other _____

Inlet Line Size _____

No. in Family _____

Calculation for Hardness Setting :

Hardness in gpg

Iron in ppm x 4 =
(multiply x 4)

Total Compensated Hardness
(add adj. iron and hardness)

Use the Total Compensated Hardness number for Hardness Setting in start up programming. (Page 11)

Bypassed Hard Water Lines:

Rear Outside Spigot _____

Front Outside Spigot _____

Kitchen Cold _____

Other _____

Pre Assembly

1. Carefully remove system from carton and inspect. The system box should contain:
 - a. Softener
 - b. Bypass Valve
 - c. Plumbing Connectors
 - d. Owner's Manual
2. Remove brine system from carton and inspect. The box should contain:
 - a. Brine Tank assy.
 - b. 5 ft. Poly Brine Line
3. Attach the bypass to the unit. (see figure 1)

The bypass valve easily connects to the control valve body using nuts that only require hand tightening. Hand tighten nut connections between control valve and fittings, control valve and bypass valve, and bypass valve and installation fittings. The split ring retainer design holds the nut on and allows load to be spread over the entire nut surface area reducing the chance for leakage. The split ring design, incorporated into the bypass, allows approximately 2 degrees off axis alignment to the plumbing system. The bypass is designed to accommodate minor plumbing misalignments but is not designed to support the weight of a system or the plumbing.

4. Attach the selected connection fitting kit to the bypass. The nuts, split rings, and o-rings install the same as the bypass. (see figure 2) Connection kit sizes available are 1" NPT PVC, 3/4" or 1" Solvent Weld, 1" Sweat Copper, and 3/4" Sweat Copper. See your dealer if a specific kit is needed other than the included kit.

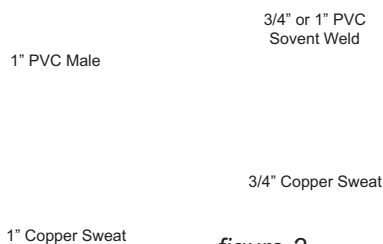

figure 2

Tip:

Take a moment to fill out the information sections in the Owner's Manual. It can be a valuable tool in the future to have all the installation data available to answer any questions.

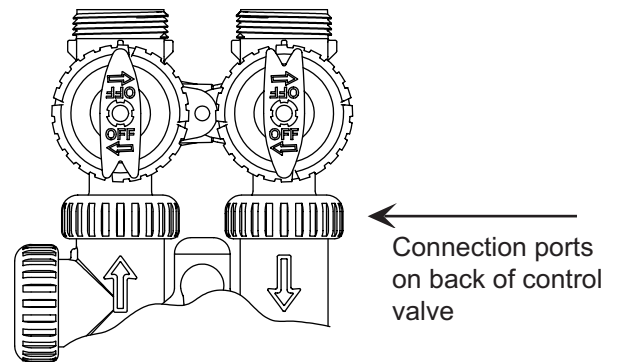

figure 1

Tip:

Do not use Vaseline, oils, or any petroleum lubricants on o-rings. A silicon lubricant may be used on black o-rings only.

Caution:

When assembling the inlet/outlet fitting kit, connect the fittings to the plumbing first. Then attach the nut, split ring, and o-ring after the fitting has cooled or dried. Heat from soldering or PVC glue solvents may damage the nut, split ring, or o-ring.

Bypass Operation

The bypass valve is typically used to isolate the control valve from the plumbing system's water pressure in order to perform control valve repairs or maintenance. The **SmartChoice** bypass valve is particularly unique in the water treatment industry due to its versatility and state of the art design features. The 1" full flow bypass valve incorporates four positions including a diagnostic position that allows service work on a pressurized system while still providing untreated bypassed water to the facility or residence. Its completely non-metallic, all plastic design allows for easy access and serviceability without the need for tools.

1. Normal Operation Position: The inlet and outlet handles point in the direction of flow indicated by the engraved arrows on the control valve. Water flows through the control valve during normal operation and this position also allows the control valve to isolate the media bed during the regeneration cycle. (see figure 1)

2. Bypass Position: The inlet and outlet handles point to the center of the bypass, the control valve is isolated from the water pressure contained in the plumbing system. Untreated water is supplied to the plumbing system. (see figure 2)

3. Diagnostic Position: The inlet handle points in the direction of flow and the outlet handle points to the center of bypass valve, system water pressure is allowed to the control valve and the plumbing system while not allowing water to exit from the control valve to the plumbing. (see figure 3)

4. Shut Off Position: The inlet handle points to the center of the bypass valve and the outlet handle points in the direction of flow, the water is shut off to the plumbing system. If water is available on the outlet side of the softener it is an indication of water bypass around the system (i.e. a plumbing connection somewhere in the building bypasses the system). (see figure 4)

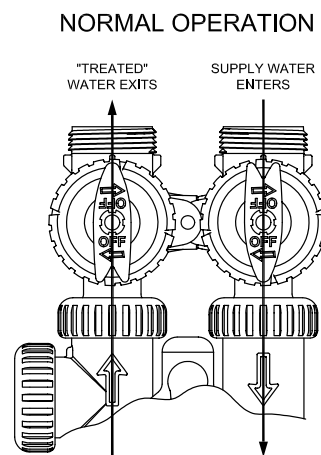

figure 1

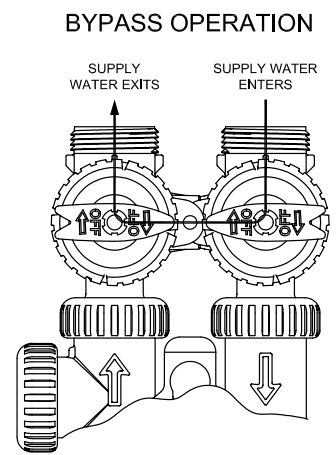

figure 2

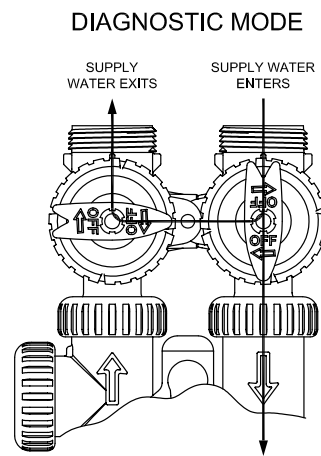

figure 3

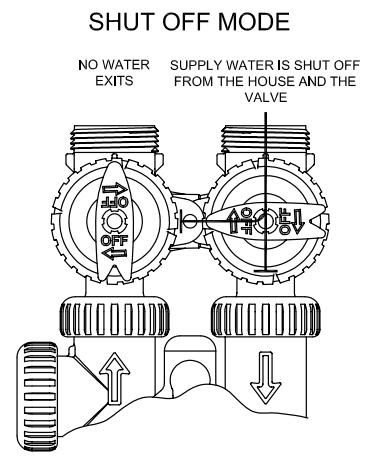

figure 4

Installation

Softener Placement

1. Find a location with accessibility to:
 - A. The main inlet water supply or pre-plumbed connection point
 - B. Adequate drain fixture, capable of 5 gallons per minute flow
 - C. Electrical Outlet
2. Place unit in the desired location. If the floor is not level the unit may be leveled with the built in adjustable base by lightly tapping the unit on the floor.
3. There should be a minimum of 12' of **Water Line** between the softener and the water heater.
4. Before connecting the lines:
 - a. Turn off electric or gas to water heater.
 - b. Turn off main water supply to building and drain off pressure to all cold water outlets.
 - c. Determine which outlets are to be bypassed and make provisions to connect them before the softener.
 - d. It is highly recommended to provide an inlet shut off valve near the unit.
 - e. The inlet water line should be a minimum of 3/4" in size. If yours is smaller, consult your dealer for required adjustments.
5. With the above considerations, connect the water line to the inlet of the unit which is designated by a gray arrow on the bypass pointing toward the control valve.
6. Connect the outlet which is designated by a gray arrow pointing away from the control valve to the water line that feeds the rest of the building.
7. If the plumbing system is metal pipe (ex. - copper), install a jumper ground wire and grounding clamps between the inlet and outlet pipes to retain continuity of the plumbing.

All plumbing must be done in accordance with local plumbing codes.

Caution:

The control valve, fittings and/or bypass are designed to accommodate minor plumbing misalignments but are not designed to support the weight of a system or the plumbing.

Do not use Vaseline, oils, other hydrocarbon lubricants or spray silicone anywhere. A silicon lubricant may be used on black o-rings but is not necessary. **Avoid any type of lubricants, including silicone, on red or clear lip seals.**

The nuts and caps are designed to be unscrewed or tightened by hand or with the special plastic wrench. If necessary, pliers can be used to unscrew the nut or cap. Do not use a pipe wrench to tighten or loosen nuts or caps. Do not place screwdriver in slots on caps and/or tap with a hammer.

Do not use pipe dope or other sealants on threads. Teflon tape must be used on the threads of the 1" NPT elbow or the 1/4" NPT connection and on the threads for the drain line connection. Teflon tape is not necessary on the nut connection or caps because of o-ring seals.

When assembling the installation fitting package (inlet and outlet), connect the fitting to the plumbing system first and then attach the nut, split ring and o-ring. Heat from soldering or solvent cements may damage the nut, split ring or o-ring. Solder joints should be cool and solvent cements should be set before installing the nut, split ring and o-ring. Avoid getting primer and solvent cement on any part of the o-rings, split rings, bypass valve or control valve.

Tip: If there is a three way bypass in the existing plumbing, inspect it to make sure the bypass valve shuts off 100% when closed.

Installation

- Connect the drain on the softener to an approved air gap drain. When using 5/8" poly tubing for the drain line, connect the nut to the line as illustrated in *figure 1*. If copper line is used, be sure to pre-sweat and cool pipe and fittings before attaching to drain fitting on unit.

Brine System Placement

- Find a smooth, level location clean and free of debris for the brine system. Locate and place the brine system within 15 feet of the softener (15 feet maximum brine line distance). Connect the brine line to the brine tank and the softener with the supplied 3/8" O.D. poly tubing (see *figure 2*).
- Connect overflow fitting with 5/8" poly tubing and run to a floor drain or through the floor to the crawl space.

Note: This is a gravity drain and must run at a downward slope from the fitting. It would only be used in the event of a malfunction in the system.

Turning on Water:

- With all plumbing connections made, make sure the bypass is in the "bypass" position (see *figure 3*). Slowly turn on the water supply valve until lines are pressurized. At a nearby faucet, turn on cold water and let it run for 2 - 3 minutes to flush debris (solder, pipe tape, glue, etc.) from the plumbing. Check for water leaks. If any leaks are found, repair them immediately before proceeding.
- After confirming no leaks exist, proceed to start up instructions on page 12.

Caution:

Make sure all plumbing connections are completed before turning on water. Check for and repair any leaks before proceeding with start up of system.

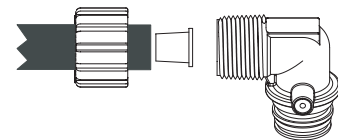

Drain Fitting

figure 1

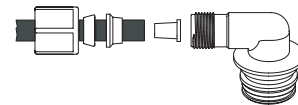

Brine Fitting

figure 2

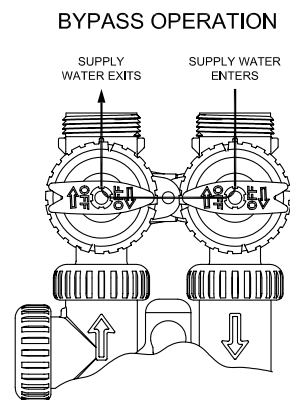
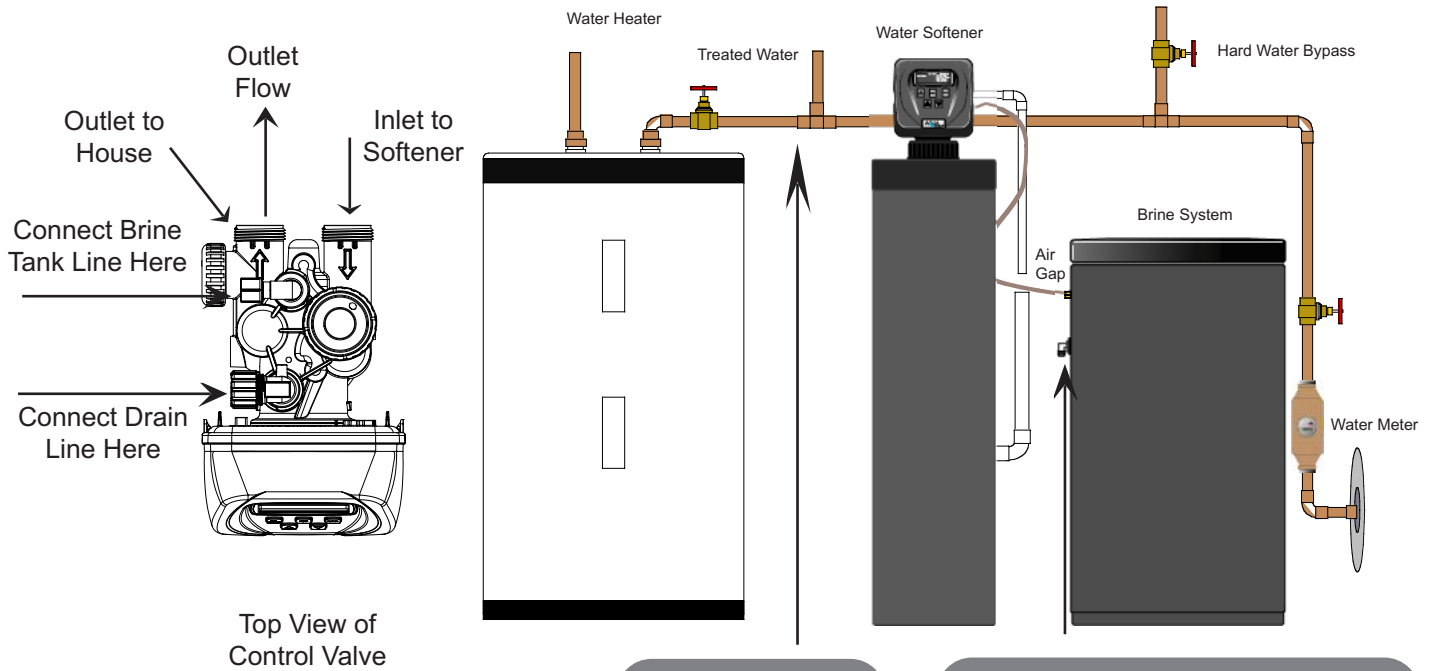

figure 3

Installation

City Water Installation:



Note:
Minimum of 12 feet of line between softener and water heater

Note:
Overflow gravity drain - Connect hose and run to floor drain or through floor to crawl space. This is used only in the event of a malfunction.

Well Water Installation:

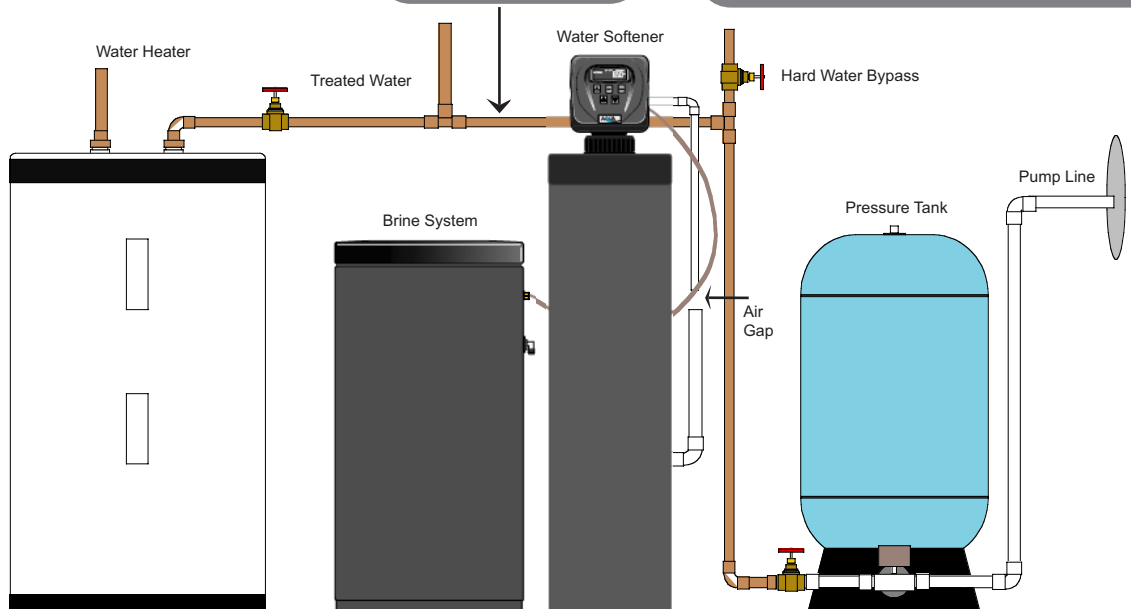

Start Up

Put Unit into Service:

1. Add 6" of water to the brine tank (if tank has a salt shelf, about 1" above shelf).
2. Plug the transformer into a 110 volt receptacle. The control will place itself in the "Softening" mode and will flash 12:00 on the display.
3. Set the current time of day. (see page 13)
4. Push and hold the "REGEN" button for 3 seconds. The system will advance to the "Backwash" position.
5. Slowly open the inlet to the bypass. (see page 8, figure 3)
6. Water will run to the drain. Let it run 5 minutes or until the the water to drain is clear.
7. Push "REGEN" button and release. The control will advance to the "BRINE" position. Let cycle run for several minutes to confirm the water is removed from the brine tank to a level below the salt shelf.
8. Push "REGEN" button and release. (see note at right) The control will advance to the next cycle. Keep pushing "REGEN" button until the control reaches the "FILL" position. Let the control complete this cycle automatically to fill the brine tank to the proper level. The control will then return to the service ("SOFTENING") position.
9. When the control has reached the service position, fill the brine tank with salt. Open the outlet handle on bypass. (see page 8, figure 1)
10. Proceed to the Programming instructions. After programming, the system should be disinfected.

To Disinfect the System:

1. Add 1.2 fluid ounce of 5.25% sodium hypochlorite solution (household bleach; Clorox, Bo Peep, etc.) for each cubic foot of resin to the brine well of the brine tank. (the 4" tube with a cap on it inside of the brine tank)
2. Press "REGEN" for 3 seconds to start a normal regeneration. Allow the system to complete the regeneration.

Note:

Make sure that the electrical outlet used is an uninterrupted outlet (such as outlet that is operated by a switch).

All electrical connections must be connected according to local codes.

Note:

When pushing the "REGEN" button to advance cycles, let the control reach the next cycle before pushing the "REGEN" button again.

Disinfection:

The materials of construction of the modern water conditioner will not promote bacterial growth, nor will these materials contaminate a water supply. However, the normal conditions that exist during shipment, storage and installation make it advisable to disinfect a conditioner after installation, before the conditioner is used to treat potable water. In addition, during normal use, a conditioner may become fouled with organic matter, or in some cases, with bacteria from the water supply. Therefore every conditioner should be disinfected after installation, some will require periodic disinfection during their normal life.

Programming

Set Time of Day:

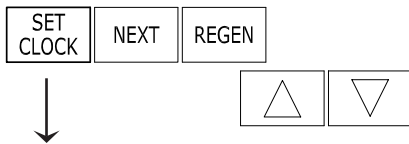

1. Press "SET CLOCK"

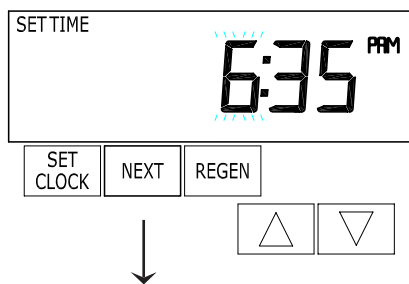

2. Current Time (hour): Set the hour of the day using "Up" or "Down" buttons. AM/PM toggles after 12. Press "NEXT" to go to step 3.

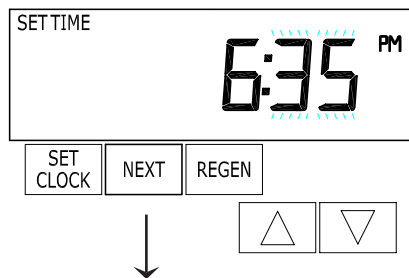

3. Current Time (minutes): Set the minutes of the day using "Up" or "Down" buttons. Press "NEXT" to exit Set Clock. Press "REGEN" to return to previous step.

Return to Normal Operation

Note:

If the power goes out for less than two hours, the current time will remain correct. If the power outage is extended, the time of day will flash, and should be reset. All other programming will be retained.

Programming

Installer Displays/Settings:

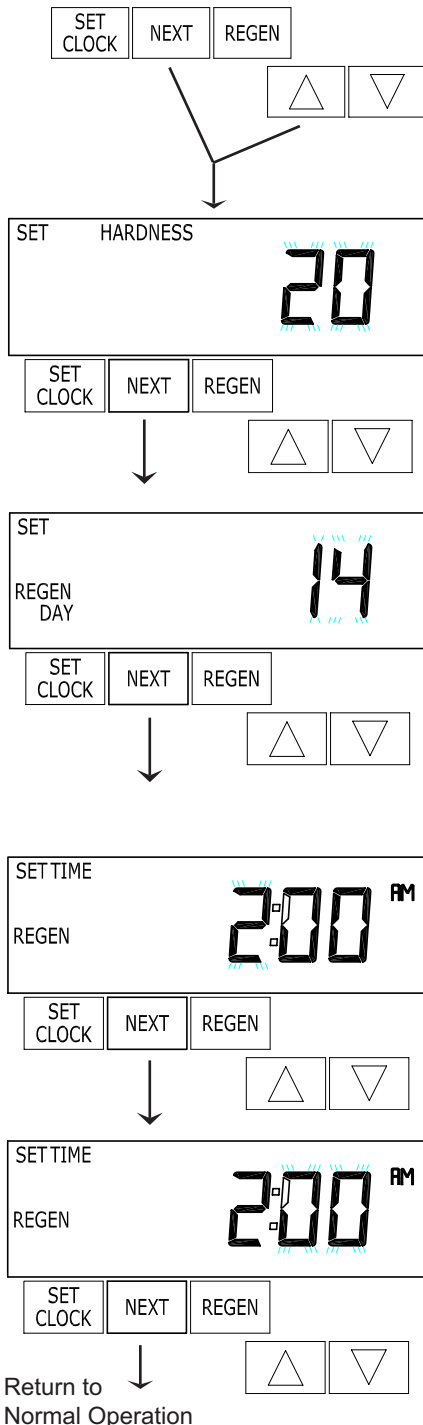

1. Press “NEXT” and “Up” simultaneously for 3 seconds.

2. Hardness: Set the amount of hardness in grains per gallon of hardness. Use the “Total Compensated Hardness” number from page 6. Use the “Up” and “Down” buttons to set the hardness number. Press “NEXT” to go to the next step.

3. Day Override: Maximum allowable days between regenerations. Can be set to “OFF” to regenerate based only on gallons used. If a number is set (1-28), regeneration is based on gallons unless the specified number of days is reached. The systems then regenerates at the programmed time and the gallon capacity is reset. Press “NEXT” to go to the next step.

4. Next Regeneration Time (hour): Set the hour of day for regeneration using the “Up” or “Down” buttons. Press “NEXT” to set minutes.

5. Next Regeneration Time (minutes): Set the minutes of day for regeneration using the “Up” or “Down” buttons. Press “NEXT” to exit program and return to normal operation.

Note:

To initiate a manual regeneration immediately, press and hold the “REGEN” button for three seconds. The system will begin to regenerate immediately.

Programming

User Displays/Settings:

“SOFTENING” flashes if water is being used and is counting gallons.

“REGEN TODAY” will flash if a regeneration is expected at next preset regeneration time.

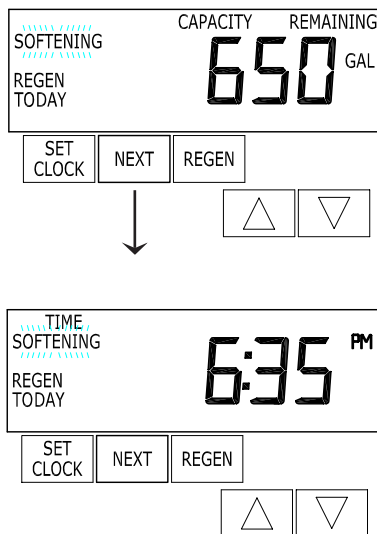

1. Capacity Remaining: Displays gallon capacity remaining before a regeneration. Press “NEXT” to go to current time.

2. Time of Day: Displays current time of day. Press “NEXT” to go to capacity remaining.

Note:

When in normal operating mode, either the Time of Day or the Capacity Remaining can be displayed. Press the “NEXT” button to toggle between the two displays.

Regeneration Mode:

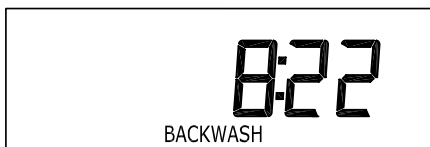

1. Typically a system is set to regenerate at a time of low water usage. An example of a time with low water usage is when a household is asleep. If there is a demand for water when the system is regenerating, untreated water will be used.

2. When the system begins to regenerate, the display will change to include information about the step of the regeneration process and the time remaining for that step to be completed. The system runs through the steps automatically and will reset itself to provide treated water when the regeneration has been completed.

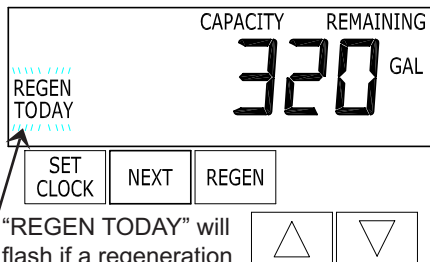

“REGEN TODAY” will flash if a regeneration is expected “tonight”.

3. Sometimes there is a need to regenerate the system, sooner than the system calls for it, usually referred to as manual regeneration. There may be a period of heavy water usage because of guests or a heavy laundry day.

4. To initiate a manual regeneration immediately, press and hold the “REGEN” button for three seconds. The system will begin to regenerate immediately.

Service

Removing & Reinstalling SmartChoice Control Valve:

Removing the Control Valve from the Media Tank:

1. Turn Bypass to the "Bypass" Position. (see diagram on page 8, figure 2)
2. Push regen button for 3 seconds to engage cycle - this will relieve the pressure in the system. see note at right
3. Once water has stopped running through the drain line, the pressure has been relieved off of the system.
4. Once the pressure is relieved, remove the Drain line from the control by pulling the lock clip. see figure 1
5. Next, remove the brine line that is connected to the salt tank by pulling the lock clip. see figure 1
6. Loosen the connection nuts between the valve and the bypass. see figure 1
7. Once the nuts are loose you may pull the system away from the plumbing. see note at right
8. With the system off of the plumbing, you can loosen the base nut to remove the valve from the media tank. see figure 2

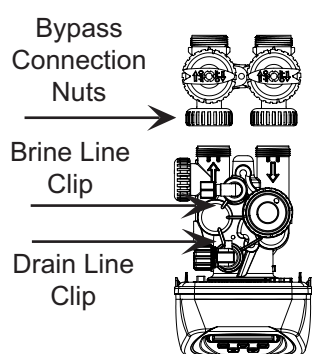

figure 1

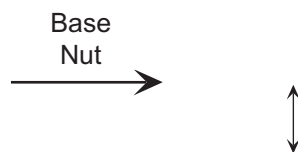

figure 2

Note:

Make sure the valve moves to the "Backwash" cycle - Look at the message on the digital display. If "Backwash" is not the first cycle on your system, wait until the control stops at the first cycle. Then press the regen button again and wait for the valve to complete changing to the next cycle.

Repeat this until you see "Backwash" designated on the display.

Once you have engaged the backwash cycle, unplug the system from the electrical outlet.

Note:

Make sure that the water pipes are supported when the system has been pulled off of the connection fittings.

Note:

Have a towel handy to absorb any water that spills during this service.

Note:

Normal Threads - Facing the unit from the front, loosen the base nut by turning from left to right.

Service

Re-installing a replacement Control Valve:

1. Place the new control valve over the base connection, insert the connection fitting into the base. *see page 16 figure 2*
2. Thread the base nut on to the base adapter - do not tighten more than hand tight.
3. Once the control valve is mounted on the media tank, move the system to align with the pipe connections.
4. Slide the system onto the pipe connections at the bypass valve.
5. Thread the connection nuts onto the valve threads -Clockwise thread direction.
6. Do not over tighten, these connections have an O-Ring seal, Hand Tight Only.
7. Insert Brine Line into it's position and install the lock clip. (*see page 16 figure 1*)
8. Insert the Drain line into it's position and install the lock clip. (*see page 16 figure 1*)
9. Plug unit into the electrical outlet.
10. Press "Next" and "Regen" buttons to reset control.
11. Set clock to current time of day.
12. Carefully turn water on to the system, open just the inlet valve handle on the bypass. *see figure 3*
13. Examine all connections to ensure that there is a 100% seal with No Water Leaks.
14. Press "Regen" for 3 seconds to start a regeneration.
15. Let the system finish a complete regeneration.
16. Open the second valve handle (outlet) on the bypass.
see figure 3

Caution:

Tighten base and connection nut fittings **Hand Tight** only.

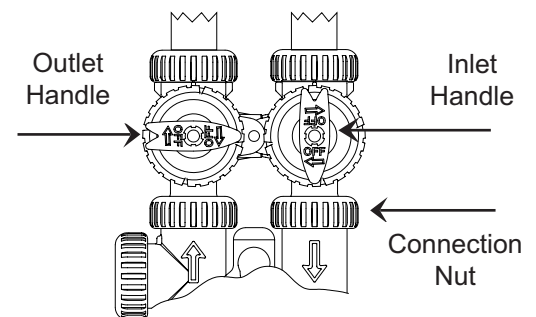

figure 3

Note:

When turning water back on, if there are any leaks detected, immediately turn off the water, loosen the leaky fitting or fittings, check o-rings - clean and reseal, and re-connect fittings. Turn on water and make sure there are no leaks before continuing return to service.

Service

Cleaning the Brine Tank:

1. Remove the brine tank cover.
2. Scoop out as much old salt as possible.
3. Disconnect brine tubing from safety brine valve at brine well.
4. Remove safety brine valve from brine well.
5. Place a hand in brine well to hold overflow nut and remove two piece overflow.
6. Remove brine well and grid plate (salt shelf) from the brine tank.
7. Remove any remaining salt and impurities from brine tank.
8. Using clean water and a brush or rag, wipe and rinse inside of brine tank. Also wipe and rinse the grid plate and brine well.
9. Reassemble brine tank reversing steps 3 - 6. see note at right
10. Put brine tank in place making sure there is no debris or foreign material beneath it.
11. Reconnect brine tubing to safety brine valve.
12. Add water to the brine tank to a level of 4" above grid plate on a round brine tank or 6" above the grid plate on a square or a rectangle brine tank.
13. Add new salt. Do not use any of the old salt that came out of the brine tank.
14. Follow the disinfection instructions listed on page 12.
15. Put on brine tank cover.

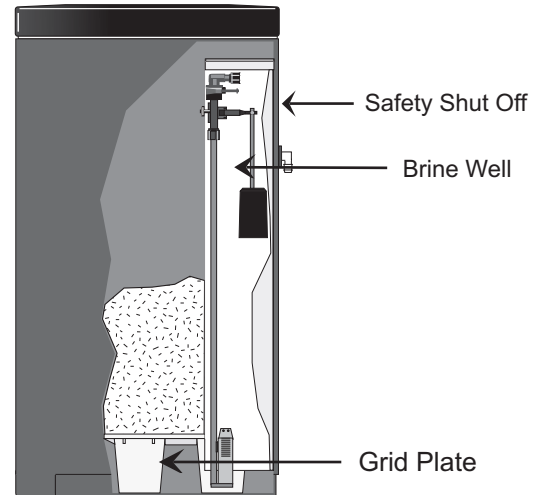

Note:

If grid plate is used and it is damaged or cracked, replace with new one.

Parts Diagrams

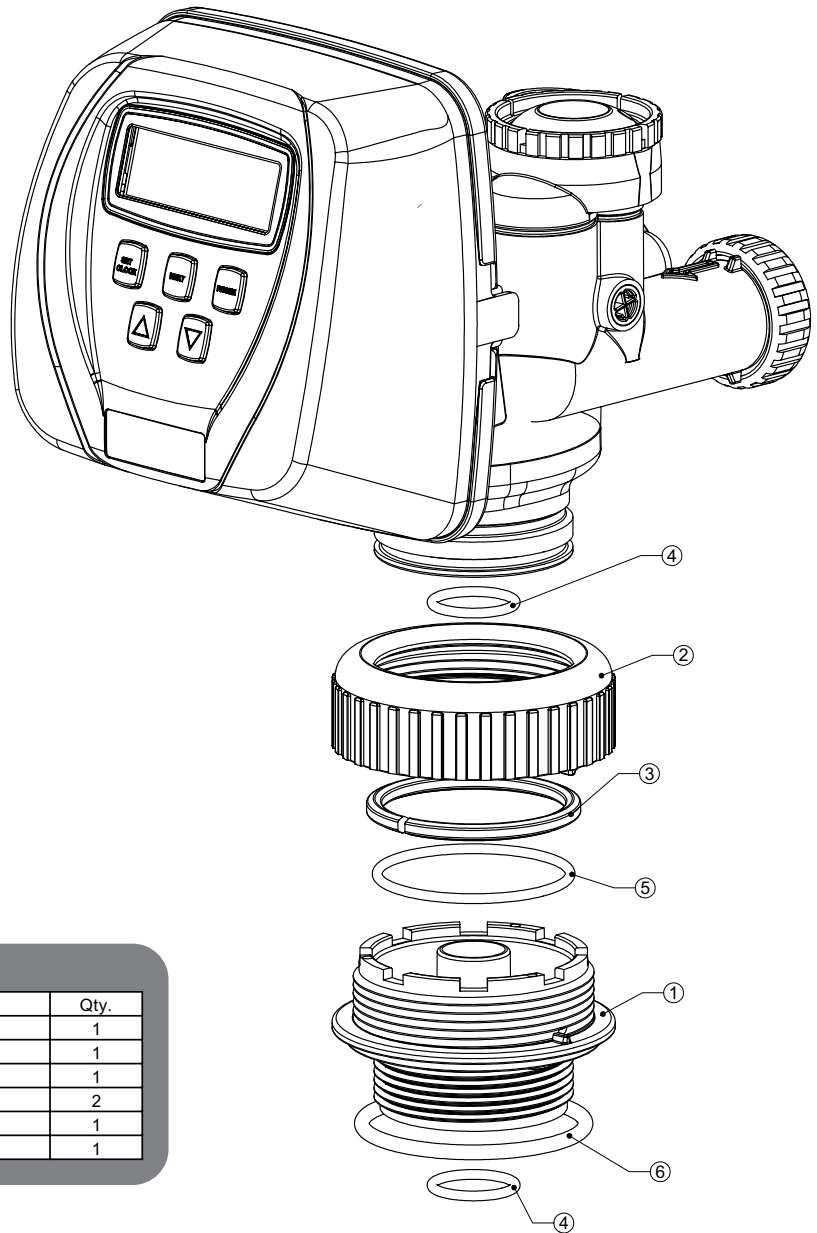

Quick Connect Assembly

No.	Part No.	Description	Qty.
1	02910182	Tank Adapter (items 1 & 4)	1
2	02910183	Tank Nut	1
3	02910184	Split Ring	1
4	02910126	O-Ring 215	2
5	02910188	O-Ring 231	1
6	02910166	O-Ring 337	1

Parts Diagrams

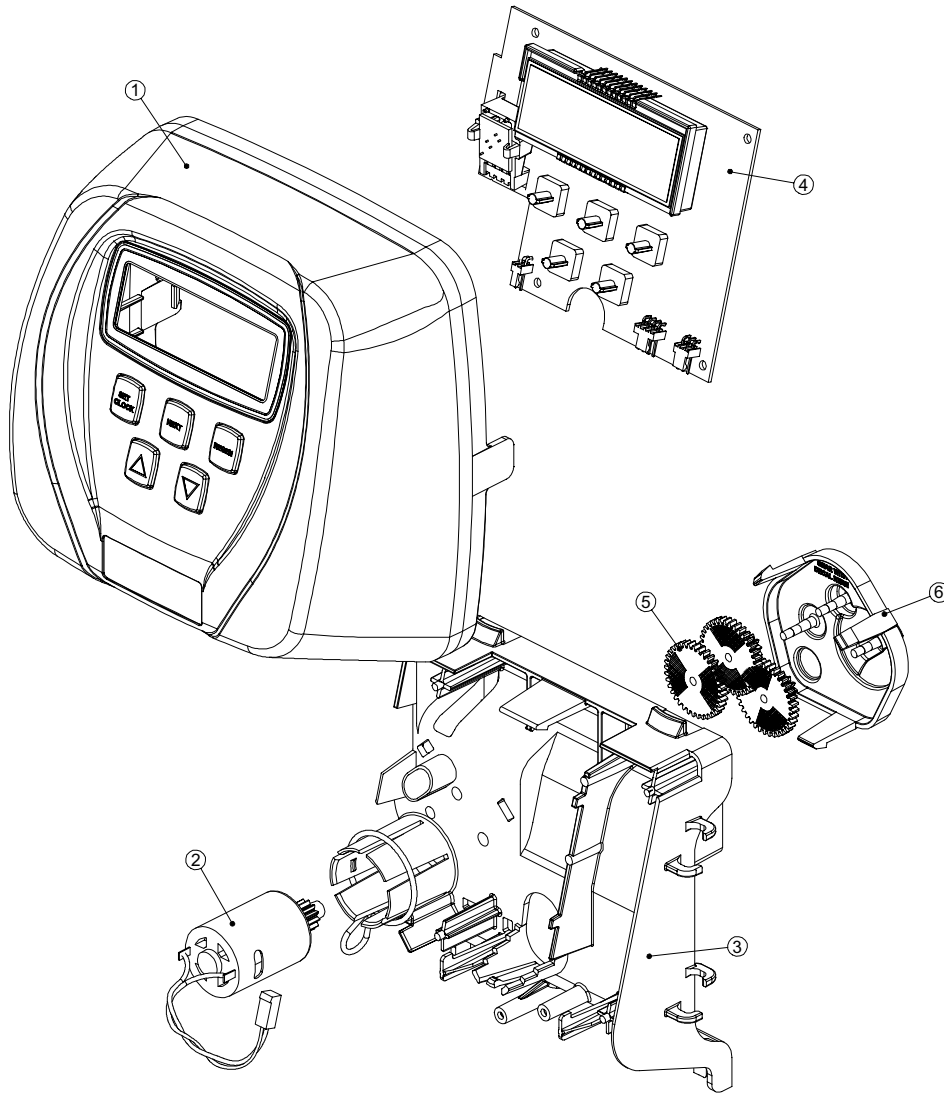

Quick Connect Assembly

No.	Part No.	Description	Qty.
1	02910186	SC Front Cover Assy	1
2	02910128	Motor	1
3	02910127	Drive Bracket and Spring Clip	1
4	02910185	SC PC Board	1
5	02910132	Drive Gear 12 x 36	3
6	02910131	Drive Gear Cover	1
(2 - 6)	02610106	Drive Assy (includes parts 2 - 6)	(1)
Not Shown	02910166	Transformer 110v - 12v	1

Parts Diagrams

Quick Connect Assembly

No.	Part No.	Description	Qty.
1	02910111	Spacer Stack Assy	1
2	02910110	Drive Cap Assy	1
3	02910141	O-Ring 228	1
4a	02910124	Piston Downflow Assy	1
4b	02910125	Piston Upflow Assy	1
5	02910160	Regenerate Piston	1
6	02910166	O-Ring 337	1

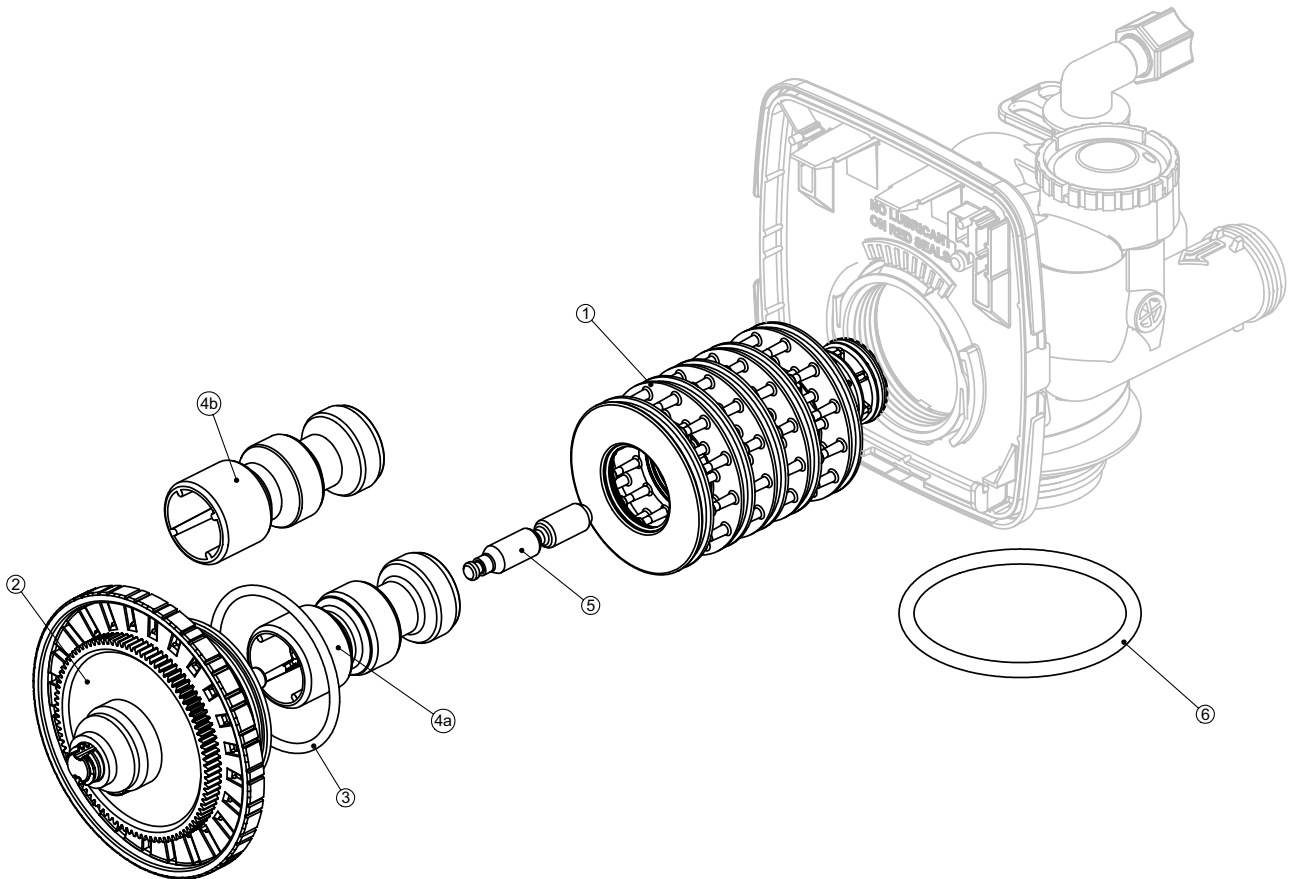

Parts Diagrams

Injector Assy

No.	Part No.	Description	Qty.
1	02910163	Injector Cap	1
2	02910149	O-Ring 135	1
3	02910164	Injector Screen	1
4	02910123	Injector Assy Z Plug	1
5	02910112	Injector Assy A Black	1
	02910113	Injector Assy B Brown	
	02910114	Injector Assy C Violet	
	02910115	Injector Assy D Red	
	02910116	Injector Assy E White	
	02910117	Injector Assy F Blue	
	02910118	Injector Assy G Yellow	
	02910119	Injector Assy H Green	
	02910120	Injector Assy I Orange	
	02910121	Injector Assy J Light Blue	
02910122	Injector Assy K Light Green		
Not Shown	02910158	O-Ring 11 (Injector)	1
Not Shown	02910159	O-Ring 13 (Injector)	1

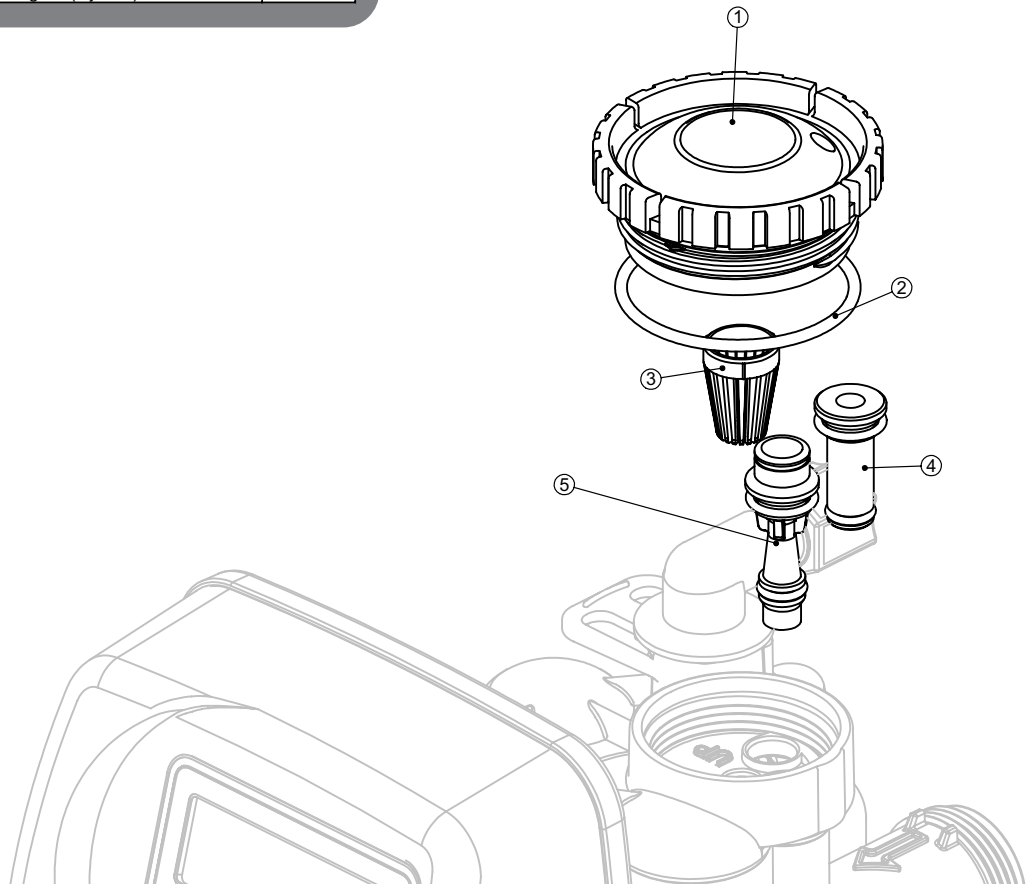

Parts Diagrams

Refill Port

No.	Part No.	Description	Qty.
1	02910173	Refill Port Plug Assy	Required for Backwash Only Systems
2	03310730	Elbow Locking Clip	1
3	03310738	Polytube Insert 3/8"	1
4	03310732	Nut 3/8"	1
5	03310740	Elbow Cap	1
6	02910154	O-Ring 019	1
7	02910155	Refill Flow Control Retainer Assy	1
8	02910167	Refill Flow Control	1
Not Shown	03310725	Elbow 1/2" w/ Nut and Insert	Option

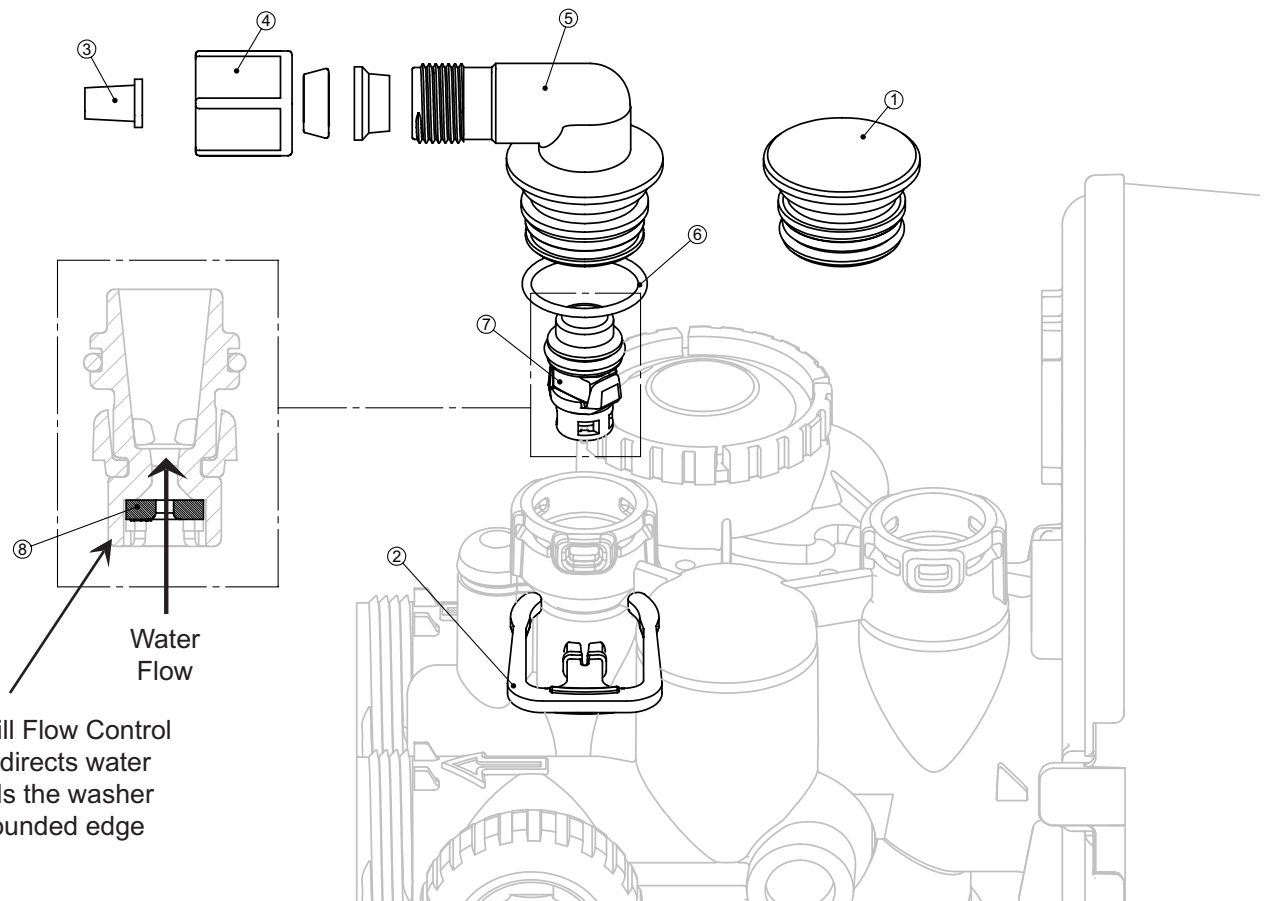

Proper Refill Flow Control orientation directs water flow towards the washer face with rounded edge and text.

Parts Diagrams

3/4" Drain Assy

No.	Part No.	Description	Qty.
1	03310730	Elbow Locking Clip	1
2	02950122	Polytube Insert 5/8"	1
3	02950121	Nut 3/4" Drain Elbow	1
4	02910152	Drain Elbow 3/4" Male Assy	1
5	02910154	O-Ring 019	1
6	02910153	DLFC Retainer Assy	1
7	02950124	DLFC 0.7 gpm for 3/4"	One DLFC must be used if 3/4" fitting is used
	02950125	DLFC 1.0 gpm for 3/4"	
	02950126	DLFC 1.3 gpm for 3/4"	
	02950127	DLFC 1.7 gpm for 3/4"	
	02950128	DLFC 2.2 gpm for 3/4"	
	02950129	DLFC 2.7 gpm for 3/4"	
	02950130	DLFC 3.2 gpm for 3/4"	
	02950131	DLFC 4.2 gpm for 3/4"	
	02950132	DLFC 5.3 gpm for 3/4"	
	02950133	DLFC 6.5 gpm for 3/4"	
	02950134	DLFC 7.5 gpm for 3/4"	
02950135	DLFC 9.0 gpm for 3/4"		
02950136	DLFC 10.0 gpm for 3/4"		

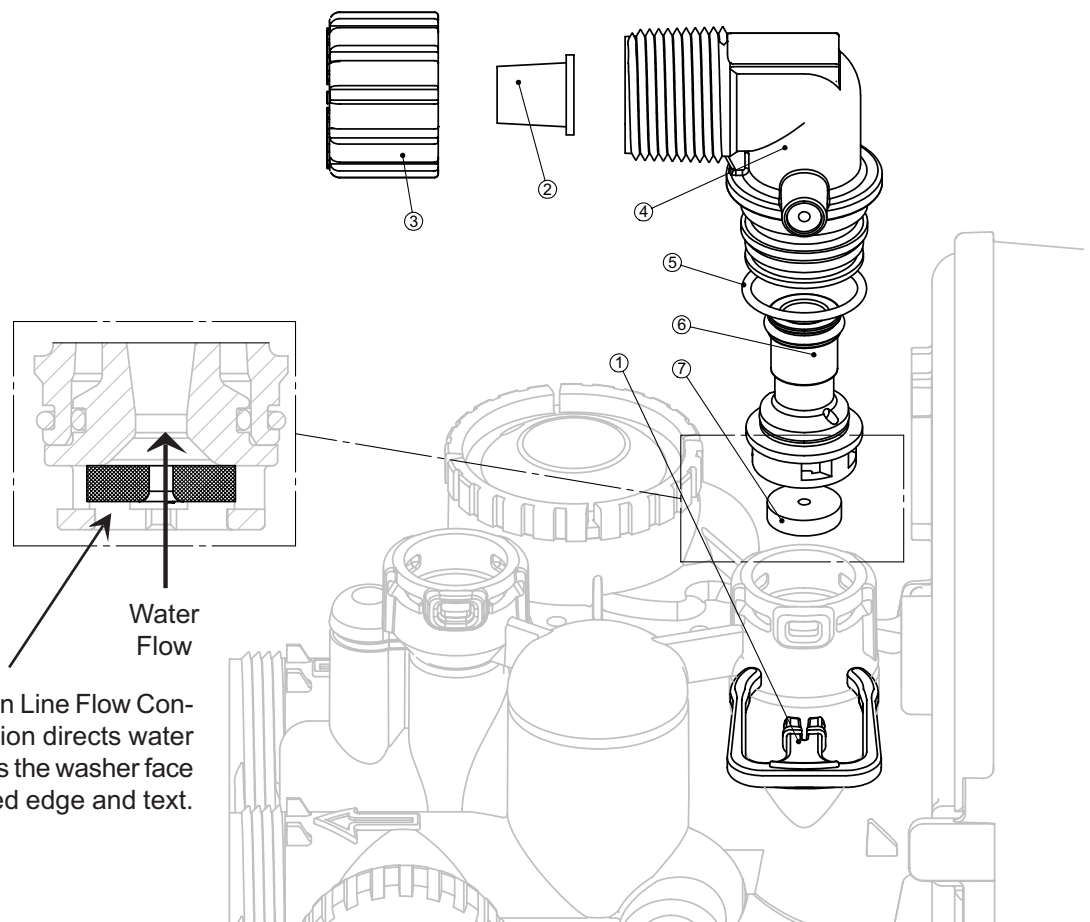

Proper Drain Line Flow Control orientation directs water flow towards the washer face with rounded edge and text.

Parts Diagrams

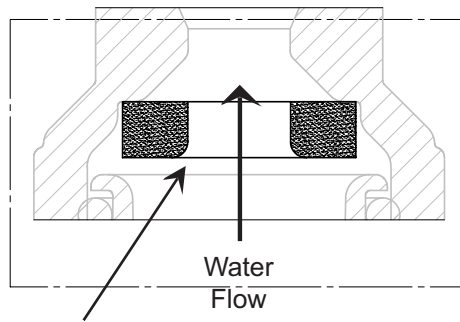

Proper Drain Line Flow Control orientation directs water flow towards the washer face with rounded edge and text.

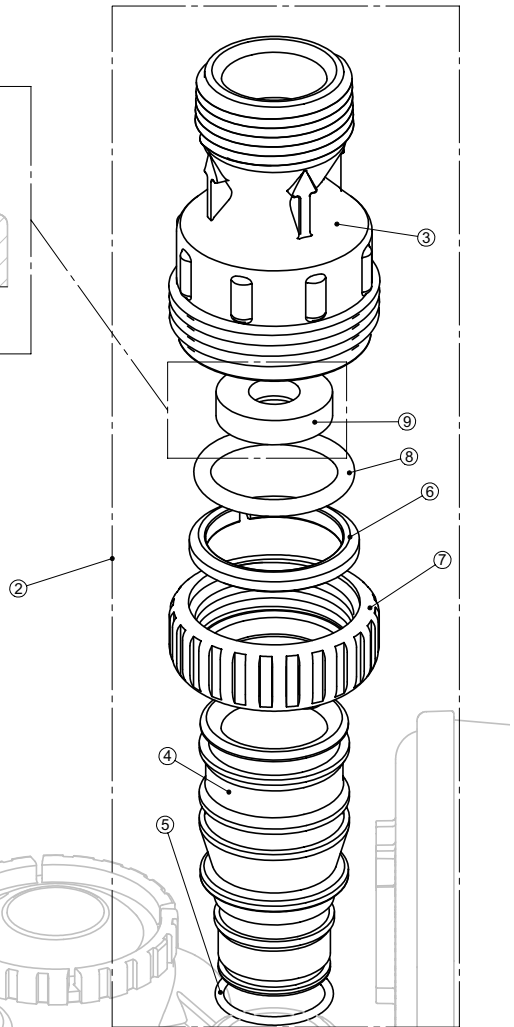

Drain Assy 1"

No.	Part No.	Description	Qty.
1	03310730	Elbow Locking Clip	1
2	02950122	Drain Fitting 1" Straight	1
3	02950121	Drain Fitting 1" Body	1
4	02910152	Drain Fitting 1" Adapter	1
5	02910154	O-Ring 019	1
6	02910153	Split Ring	1
7	02950124	Nut 1" QC	One DLFC must be used if 1" fitting is used
8	02950125	O-Ring 215	
9	02950126	DLFC 9.0 gpm for 1"	
	02950127	DLFC 10.0 gpm for 1"	
	02950128	DLFC 11.0 gpm for 1"	
	02950129	DLFC 13.0 gpm for 1"	
	02950130	DLFC 15.0 gpm for 1"	
	02950131	DLFC 17.0 gpm for 1"	
	02950132	DLFC 20.0 gpm for 1"	
	02950133	DLFC 25.0 gpm for 1"	

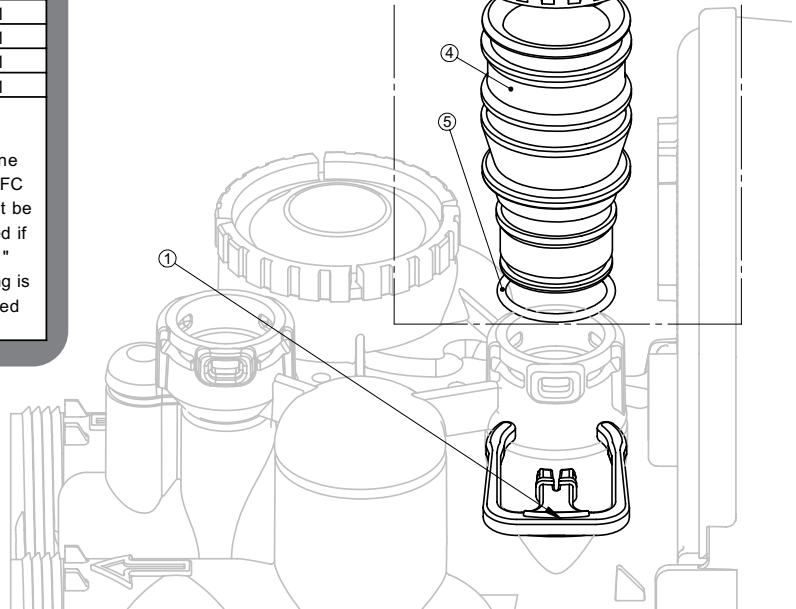

Parts Diagrams

Meter Assy

No.	Part No.	Description	Qty.
1	02910148	Nut 1" QC	1
2	02910108	Meter Assy	1
3	02910140	Turbine Assy	1
4	02910126	O-Ring 215	1
5	02910109	Meter Plug Assy	1

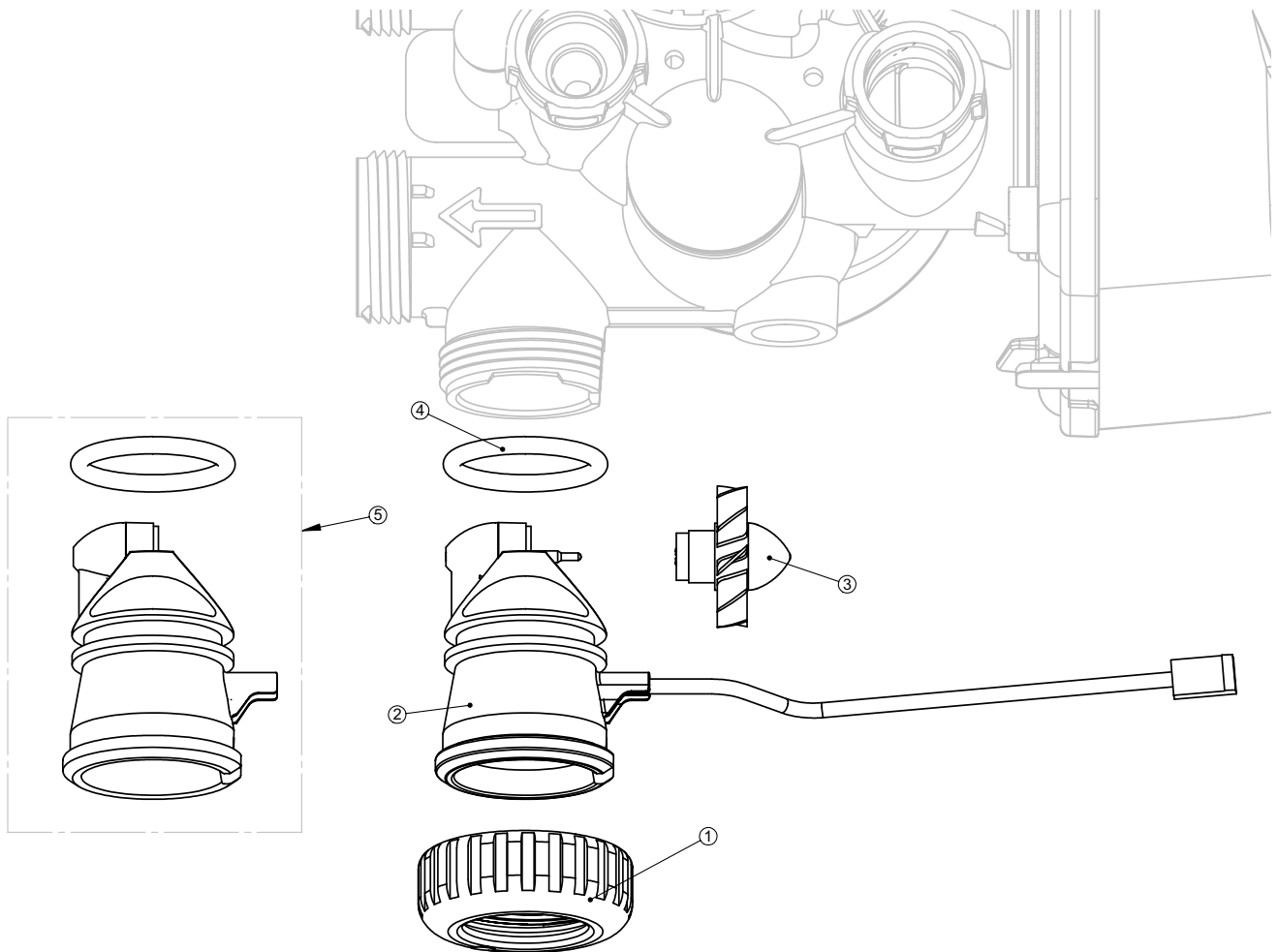

Parts Diagrams

1" PVC Male NPT Elbow Assy

No.	Part No.	Description	Qty.
1	02910148	Nut 1" Quick Connect	2
2	02910147	Split Ring	2
3	02910126	O-Ring 215	2
4	02910146	Fitting 1" PVC Male NPT Elbow	2

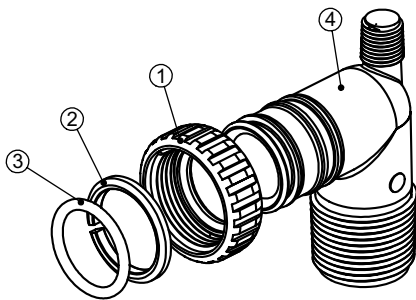

3/4" & 1" PVC Solvent Elbow Assy

No.	Part No.	Description	Qty.
1	02910148	Nut 1" Quick Connect	2
2	02910147	Split Ring	2
3	02910126	O-Ring 215	2
4	02910172	Fitting 3/4" & 1" PVC Solvent 90	2

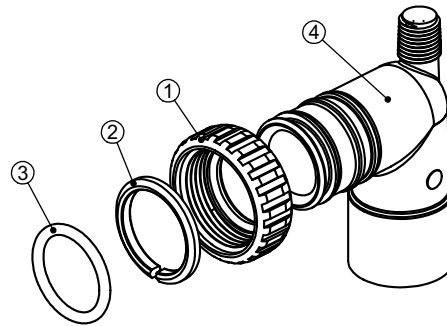

1" Brass Sweat Assy

No.	Part No.	Description	Qty.
1	02910148	Nut 1" Quick Connect	2
2	02910147	Split Ring	2
3	02910126	O-Ring 215	2
4	02910170	Fitting 1" Brass Sweat	2

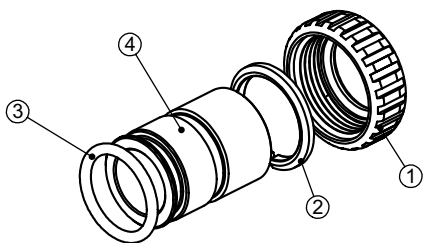

3/4" Brass Sweat Assy

No.	Part No.	Description	Qty.
1	02910148	Nut 1" Quick Connect	2
2	02910147	Split Ring	2
3	02910126	O-Ring 215	2
4	02910171	Fitting 3/4" Brass Sweat	2

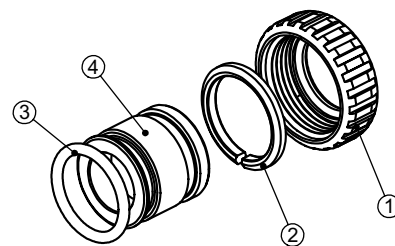

Parts Diagrams

Vertical Adapter Assy (Not Shown)

Part No.	Description	Qty.
02910148	Nut 1" Quick Connect	2
02910147	Split Ring	2
02910126	O-Ring 215	2
02950120	Bypass Vertical Adapter Assy	2

Bypass Valve

No.	Part No.	Description	Qty.
1	02910148	Nut 1" Quick Connect	2
2	02910147	Split Ring	2
3	02910126	O-Ring 215	2
4	02910142	Bypass 1" Rotor	2
5	02910143	Bypass Cap	2
6	02910187	Bypass Handle Gray	2
7	02910144	Bypass Rotor Seal Retainer	2
8	02910149	O-Ring 135	2
9	02910150	O-Ring 112	2
10	02910151	O-Ring 214	2

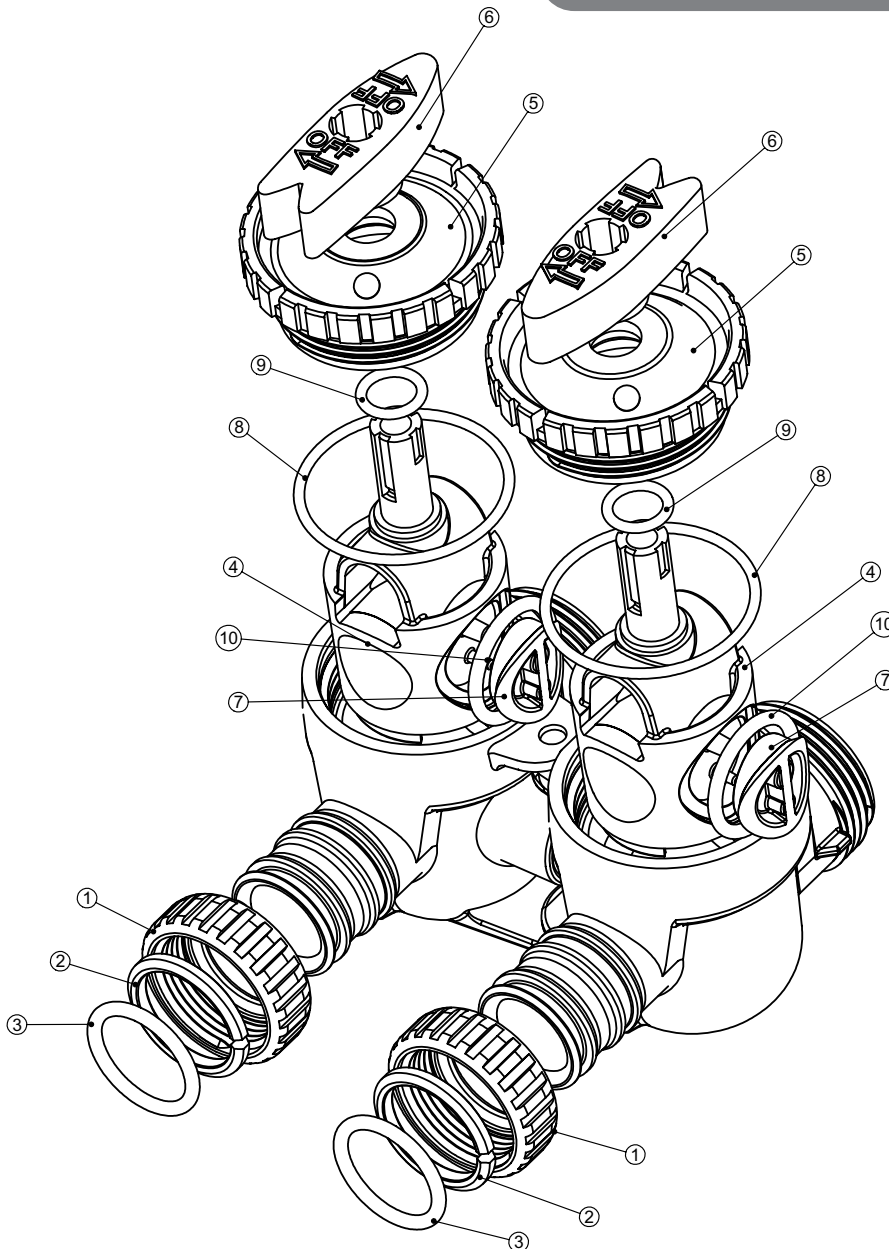

Parts Diagrams

Valve Wrench

No.	Part No.	Description	Qty.
Shown	02950123	Valve Wrench	1

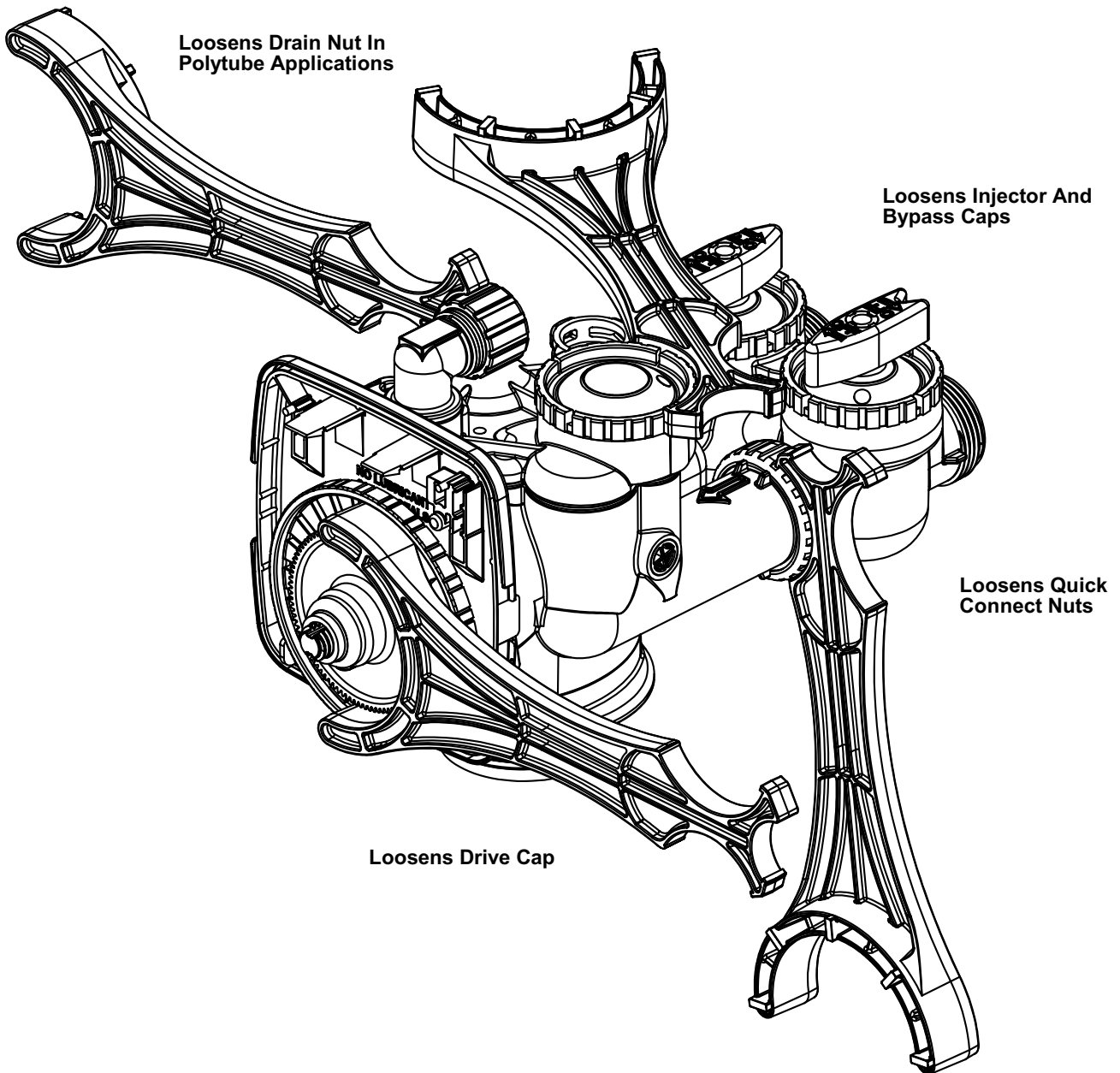

Parts Diagrams

Tank Assemblies

No.	Part No.	Description	Qty.
1a	04210890	Tank Shroud for 44" Tank	1
1b	04210891	Tank Shroud for 47" Tank	1
1c	04210892	Tank Shroud for 54" Tank	1
2	see data sheet	Resin Tank	1
3a	03510871	Turbulator Distributor (spec size)	1
3b	03510877	Standard Distributor (spec size)	1
4	03810800	High Capacity Resin	spec size
5	spec size	Brine Tank Cover	1
6a	03410758	Brine Tank w/ IM Cover 18x40	1
6b	03410755	Brine Tank w/ IM Cover 11x11x36	1
7	spec size	Salt Shelf	1*
8	spec size	Brine Well	1
9	03310663	Brine Well Cap	1
10	03310720	474 Safety Brine Valve	1
11	03310715	474 Float Assy	1
12	03310710	474 Air Check Assy	1
13	03310654	Overflow Assy	1

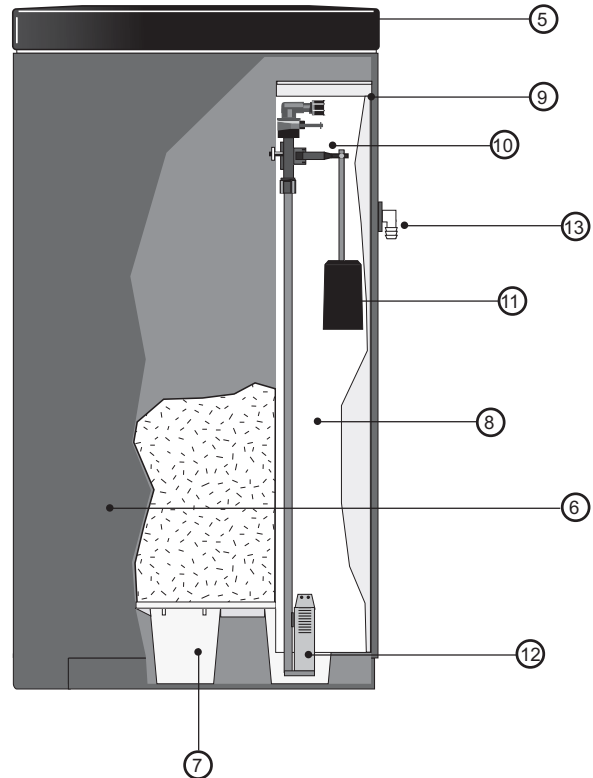
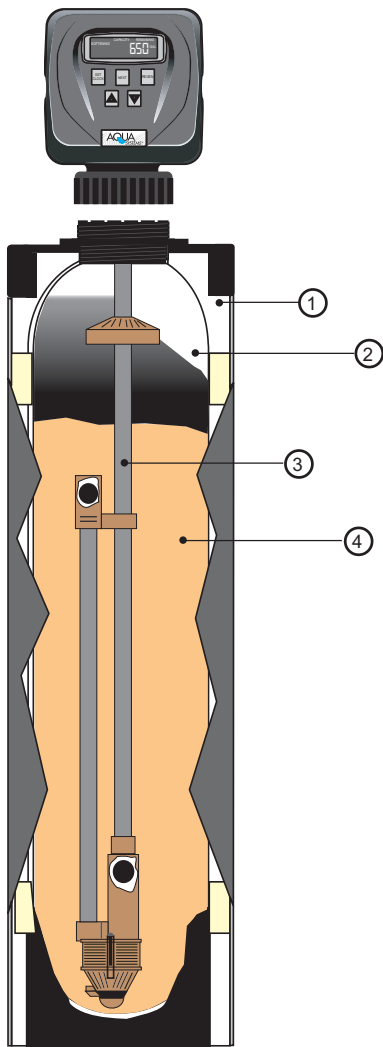

Service Guide

Drive Assembly

Always unplug the system from the electrical outlet before performing service on the unit. Remove the valve cover to access the drive assembly.

Disconnect the power source plug (black wire) from the PC board prior to disconnecting the motor or water meter plugs from the PC board. The motor plug connects to the two-pin jack on the left-hand side of the PC board. The power source plug connects to the four-pin jack. The four-pin jack is between the two-pin and three-pin jacks. The water meter plug (gray wire) connects to the three-pin jack on the far right-hand side of the PC board.

The PC board can be removed separately from the drive bracket but it is not recommended. Do not attempt to remove the display panel from the PC board. Handle the board by the edges. To remove the PC board from the drive bracket, unplug the power, water meter and motor plugs from the PC board. Lift the middle latch along the top of the drive bracket while pulling outward on the top of the PC board. The drive bracket has two plastic pins that fit into the holes on the lower edge of the PC board. Once the PC board is tilted about 45° from the drive bracket it can be lifted off of these pins. To reinstall the PC board, position the lower edge of the PC board so that the holes in the PC board line up with the plastic pins. Push the top of the PC board towards the valve until it snaps under the middle latch, weave the power and water meter wires into the holders and reconnect the motor, water meter and power plugs.

The drive bracket must be removed to access the drive cap assembly and pistons or the drive gear cover. It is not necessary to remove the PC board from the drive bracket to remove the drive bracket. To remove the drive bracket start by removing the plugs for the power source and the water meter. Unweave the wires from the side holders. Two tabs on the top of the drive back plate hold the drive bracket in place. Simultaneously lift the two tabs and gently ease the top of the drive bracket towards your body. The lower edge of the drive bracket has two notches that rest on the drive back plate. Lift up and outward on the drive bracket to disengage the notches.

To reassemble seat the bottom of the drive bracket so the notches are engaged at the bottom of the drive back plate. Push the top of the drive bracket towards the two latches. The drive bracket may have to be lifted slightly to let the threaded piston rod pass through the hole in the drive bracket. Maintain a slight engaging force on top of the drive bracket while deflecting the bracket slightly to the left by pressing on the side of the upper right corner. This helps the drive gears mesh with the drive cap assembly. The drive bracket is properly seated when it snaps under the latches on the drive back plate. If resistance is felt before latching, then notches are not fully engaged, the piston rod is not in hole, the wires are jammed between the drive bracket and drive back plate, or the gear is not engaging the drive cap assembly.

To inspect drive gears, the drive gear cover needs to be removed. The drive gear cover is held in place on the drive bracket by three clips. The largest of the three clips is always orientated to the bottom of the drive bracket. Before trying to remove the drive gear cover, the drive bracket must be removed from the drive back plate. The drive gear cover can be removed from the drive bracket without removing the motor or the PC board. Simultaneously, push in and down on the large clip at the bottom and the clip on the left-hand side of the drive bracket behind the PC board. Keep your other fingers behind the drive gear cover so the drive gears do not drop on the ground.

Replace broken or damaged drive gears. Do not lubricate any of the gears. Avoid getting any foreign matter on the

Service Guide

reflective coating because dirt or oils may interfere with pulse counting.

The drive gear cover only fits on one way, with the large clip orientated towards the bottom. If all three clips are outside of the gear shroud on the drive bracket the drive gear cover slips easily into place.

The drive gear cover only fits on one way, with the large clip orientated towards the bottom. If all three clips are outside of the gear shroud on the drive bracket the drive gear cover slips easily into place.

The drive bracket does not need to be removed from the drive plate if the motor needs to be removed. To remove the motor, disconnect the power and motor plugs from the jacks on the PC board. Move the spring clip loop to the right and hold. Rotate the motor at least a 1/4 turn in either direction before gently pulling on the wire connectors to remove the motor. Pulling directly on the wires without rotating the motor may break the wires off the motor.

Replace the motor if necessary. Do not lubricate the motor or the gears. When reinstalling the motor gently turn the motor while inserting so that the gear on the motor meshes with the gears under the drive gear cover and the small plastic bulge engages one of the slots on the motor housing. Reconnect the motor plug to the two pronged jack on the lower left hand side of the PC board. If motor will not easily engage with drive gear when reinstalling, lift and slightly rotate motor before reinserting.

Replace the valve cover. After completing any valve maintenance, press and hold "NEXT" and "REGEN" buttons for 3 seconds or unplug power source jack (black wire) and plug back in. This resets the electronics and establishes the service piston position. The display should flash all wording, then flash the soft ware version (e.g. 154) and then reset the valve to the service position.

Drive Cap Assembly, Main Piston and Regenerant Piston

The drive assembly must be removed to access the drive cap assembly. The drive cap assembly must be removed to access the piston(s). The drive cap assembly is threaded into the control valve body and seals with an o-ring. To remove the drive cap assembly use the special plastic wrench or insert a 1/4" to 1/2" flat bladed screwdriver into one of the slots around the top 2" of the drive cap assembly so it engages the notches molded into the drive back plate around the top 2" of the piston cavity. (See Figure 5). The notches are visible through the holes. Lever the screwdriver so the drive cap assembly turns counter clockwise. Once loosened unscrew the drive cap assembly by hand and pull straight out.

The drive cap assembly contains the drive cap, the main drive gear, drive cap spline, piston rod and various other parts that should not be disassembled in the field. The only replaceable part on the drive cap assembly is the o-ring. Attached to the drive cap assembly is the main piston (down flow or up flow) and if a regenerant is used, a regenerant piston.

The regenerant piston (the small diameter one behind the main piston) is removed from the main piston by unsnapping it from its latch. Chemically clean in dilute sodium bisulfite or vinegar or replace the regenerant piston if needed. To remove the main down flow or up flow piston fully extend the piston rod and then unsnap the main piston from its latch by pressing on the side with the number. Chemically clean in dilute sodium bisulfite or vinegar or replace the main piston.

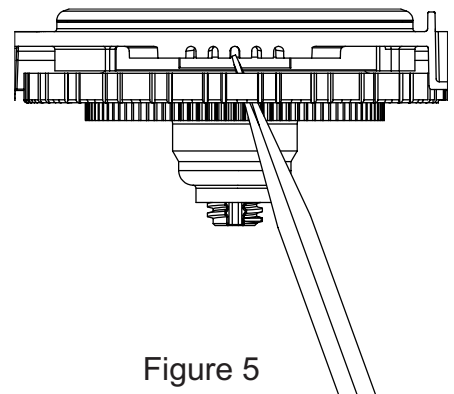

Figure 5

Service Guide

Reattach the main piston to the drive cap assembly. Reattach the regenerant piston (if needed) to the main piston. Do not lubricate the piston rod, main piston or regenerant piston. Lubricant will adversely affect the red or clear lip seals. Reinsert the drive cap assembly and piston into the spacer stack assembly and hand tighten the drive cap assembly. Continue to tighten the drive cap assembly using a screwdriver as a ratchet until the black o-ring on the spacer stack assembly is no longer visible through the drain port.

Excessive force can break the notches molded into the drive back plate. Make certain that the main drive gear still turns freely. The exact position of the piston is not important as long as the main drive gear turns freely.

Tip:

Excessive force can break the notches molded into the drive back plate. Make certain that the main drive gear still turns freely. The exact position of the piston is not important as long as the main drive gear turns freely.

Reattach the drive assembly to the control valve and connect all plugs. After completing any valve maintenance, press and hold NEXT and REGEN buttons for 3 seconds or unplug power source jack (black wire) and plug back in. This resets the electronics and establishes the service piston position. The display should flash all wording, then flash the soft ware version (e.g. 154) and then reset the valve to the service position.

Spacer Stack Assembly

To access the spacer stack assembly remove the drive assembly, drive cap assembly and piston. The spacer stack assembly can be removed easily without tools by using thumb and forefinger. Inspect the black o-rings and red or clear lip seals for wear or damage. Replace the entire stack if necessary. The spacer stack assembly has been 100% tested at the factory to insure proper orientation of one way seals. Do not disassemble the stack.

The spacer stack assembly may be chemically cleaned (dilute sodium bisulfite or vinegar) or wiped with a soft cloth.

The spacer stack assembly can be pushed in to the control valve body bore by hand. Since the spacer stack assembly can be compressed it is easier to use a blunt object (5/8" to 1-1/8" in diameter) to push the center of the assembly into the control valve body. The assembly is properly seated when at least four threads are exposed (approximately 5/8"). Do not force the spacer stack assembly in. The control valve body bore interior can be lubricated with silicone to allow for easy insertion of the entire stack. Do not use silicone or any other type of lubricant on the red or clear lip seals or the piston.

Reattach the drive cap assembly and piston(s) and the drive assembly.

After completing any valve maintenance, press and hold NEXT and REGEN buttons for 3 seconds or unplug power source jack (black wire) and plug back in. This resets the electronics and establishes the service piston position. The display should flash all wording, then flash the soft ware version (e.g. 154) and then reset the valve to the service position.

Service Guide

Injector Cap, Screen, Injector Plug and Injector

Unscrew the injector cap and lift off. Loosen cap with special plastic wrench or pliers if necessary. Attached to the injector cap is a screen. Remove the screen and clean if fouled.

The plug and/or injector can be pried out with a small screwdriver. The plug can be wiped clean. If the plug leaks replace the entire plug. The injector consists of a throat and a nozzle. Chemically clean the injector with vinegar or sodium bisulfite. The holes can be blown out with air. Both pieces have small diameter holes that control the flow rates of water to insure that the proper concentration of regenerant is used. Sharp objects, which can score the plastic, should not be used to clean the injector. Scoring the injector or increasing the diameter of the hole could change the operating parameters of the injector.

Two holes are labeled DN and UP. Check for compliance with one of the following:

- for down flow systems, the appropriate size injector is located in the “DN” hole, a plug is in the “UP” hole and that the piston is a combination of the down flow main piston and the regenerant piston;
- for up flow systems, the appropriate size injector is located in the “UP” hole, a plug is in the “DN” hole and that the piston is a combination of the up flow main piston and the regenerant piston; or
- for backwash only systems, a plug is in the “DN” hole and in the “UP” hole, and that the piston only has a down flow main piston (the regenerant piston must be removed) and a plug is in the refill flow control position.

Push the plug(s) and/or injectors firmly in place, replace the screen and hand tighten the injector cap.

Refill Flow Control Assembly or Refill Port Plug

To clean or replace the refill flow control, pull out the elbow-locking clip and then pull straight up on the elbow. Replace the elbow locking clip in the slot so that it is not misplaced. Twist to remove the white flow control retainer. The flow control can be removed by prying upward through the side slots of the retainer with a small blade flat screwdriver.

Chemically clean the flow control or the white flow control retainer using dilute sodium bisulfite or vinegar. Do not use a wire brush. If necessary, replace the flow control, o-ring on the flow control retainer, or the o-ring on the elbow.

Reseat the flow control so the rounded end is visible in the flow control. Reseat the white flow control retainer by pushing the retainer into the elbow until the o-ring seats. Remove locking clip, push down on elbow to reseal and insert locking clip.

Do not use Vaseline, oils, or other unacceptable lubricants on o-rings. A silicon lubricant may be used on the o-ring on the elbow or the white retainer.

Tip:

Do not use Vaseline, oils, or other unacceptable lubricants on o-rings. A silicon lubricant may be used on the o-ring on the elbow or the white retainer.

Service Guide

Water Meter or Meter Plug

The water meter assembly is connected to the PC board by a wire. If the entire water meter assembly is to be replaced, remove the control valve cover and remove the power source and water meter plugs from the PC board. Unlatch the drive assembly and lean it forward. Unthread the water meter wire from the side of the drive assembly and through the drive back plate. To reinstall, rethread the water meter wire through the drive back plate and the side of the drive assembly. Reattach the drive assembly and the water meter and power plugs.

If no water meter wire is visible, then a plug is installed not a water meter.

The water meter wire does not need to be removed from the PC board if the water meter is only being inspected and cleaned. To remove the water meter assembly, unscrew the meter cap on the left side of the control valve. Pliers may be used to unscrew the nut if necessary.

With the nut removed, a slot at the top of the water meter is visible. Twist a flat blade screwdriver in the slot between the control valve body and the meter. When the meter is part way out it is easy to remove the water meter from the housing. Once the water meter is removed from the control valve body, use your fingers to gently pull forward on the turbine to remove it from the shaft.

Do not use a wire brush to clean. Wipe with a clean cloth or chemically clean in dilute sodium bisulfite or vinegar. The turbine can be immersed in the chemical. Do not immerse electronics. If the turbine is scored or damaged or the bearings on the turbine are worn replace the turbine.

Do not lubricate the turbine shaft. The turbine shaft bearings are prelubricated. Do not use Vaseline, oils, or other unacceptable lubricants on the o-ring. A silicon lubricant may be used on the black o-ring.

Snap the turbine on the shaft and reinsert the water meter into the side slot. Hand tighten the nut. Do not use a pipe wrench to tighten nut.

Bypass Valve

The working parts of the bypass valve are the rotor assemblies that are contained under the bypass valve caps. Before working on the rotors, make sure the system is depressurized. Turn the gray arrow shaped handles towards the center of the bypass valve and back to the arrow direction several times to ensure rotor is turning freely.

The nuts and caps are designed to be unscrewed or tightened by hand. If necessary a pliers can be used to unscrew the nut or cap. Do not use a pipe wrench to tighten or loosen nuts or caps. Do not place screwdriver in slots on caps and/or tap with a hammer.

To access the rotor, unscrew the cap and lift the cap, rotor and handle out as one unit. Twisting the unit as you pull it out will help to remove it more easily. There are three o-rings: one under the rotor cap, one on the rotor stem and the rotor seal. Replace worn o-rings. Clean rotor. Reinstall rotor.

Service Guide

When reinstalling the gray arrow handles be sure that:

1. O-rings on both rotors face to the right when being viewed from the front of the control valve when the handle pointers are lined up with the control valve body arrows; or
2. Arrows point toward each other in the bypass position.

Since the handles can be pulled off, they could be accidentally reinstalled 180° from their correct orientation. To install the gray arrow handles correctly, keep the handles pointed in the same direction as the arrows engraved on the control valve body while tightening the bypass valve caps.

After completing any valve maintenance, press and hold “NEXT” and “REGEN” buttons for 3 seconds or unplug power source jack (black wire) and plug back in. This resets the electronics and establishes the service piston position. The display should flash all wording, then flash the software version (e.g. 154) and then reset the valve to the service position.

Tip:

After completing any valve maintenance, press and hold “NEXT” and “REGEN” buttons for 3 seconds or unplug power source jack (black wire) and plug back in.

Troubleshooting

Problem	Possible Cause	Solution
1. Timer does not display time of day	a. Transformer unplugged	a. Connect power
	b. No electric power at outlet	b. Repair outlet or use working outlet
	c. Defective transformer	c. Replace transformer
	d. Defective PC board	d. Replace PC board
2. Timer does not display correct time of day	a. Switched outlet	a. Use uninterrupted outlet
	b. Power outage	b. Reset time of day
	c. Defective PC board	c. Replace PC board
3. No softening/filtering display when water is flowing	a. Bypass valve in bypass position	a. Put bypass valve in service position
	b. Meter connection disconnected	b. Connect meter to PC board
	c. Restricted/stalled meter turbine	c. Remove meter and check for rotation or foreign material
	d. Defective meter	d. Replace meter
	e. Defective PC board	e. Replace PC board
4. Control valve regenerates at wrong time of day	a. Power outages	a. Reset control valve to correct time of day
	b. Time of day not set correctly	b. Reset to correct time of day
	c. Time of regeneration incorrect	c. Reset regeneration time
	d. Control valve set at "on 0" (immediate regeneration)	d. Check control valve set-up procedure regeneration time option
	e. Control valve set at NORMAL + on 0	e. Check control valve set-up procedure regeneration time option
5. ERROR followed by code number Error Code 1001 -Unable to recognize start of regeneration Error Code 1002 – Unexpected stall Error Code 1003 – Motor ran to long, timed out trying to reach next cycle position Error Code 1004 - Motor ran to long, timed out trying to reach home position If other Error Codes display contact the factory.	a. Control valve has just been serviced	a. Press NEXT and REGEN for 3 seconds or unplug power source jack (black wire) and plug back in to reset control valve
	b. Foreign matter is lodged in control valve	b. Check piston and spacer stack assembly for foreign matter
	c. High drive forces on piston	c. Replace piston(s) and spacer stack assembly
	d. Control valve piston not in home position	d. Press NEXT and REGEN for 3 seconds or unplug power source jack (black wire) and plug back in to reset control valve
	e. Motor not inserted fully to engage pinion, motor wires broken or disconnected, motor failure	e. Check motor and wiring. Replace motor if necessary
	f. Drive gear label dirty or damaged, missing or broken gear	f. Replace or clean drive gear
	g. Drive bracket incorrectly aligned to back plate	g. Reseat drive bracket properly
	h. PC board is damaged or defective	h. Replace PC board
	i. PC board incorrectly aligned to drive bracket	i. Ensure PC board is correctly snapped on to drive bracket

Troubleshooting

Problem	Possible Cause	Solution
6. Control valve stalled in regeneration	a. Motor not operating	a. Replace motor
	b. No electric power at outlet	b. Repair outlet or use working outlet
	c. Defective transformer	c. Replace transformer
	d. Defective PC board	d. Replace PC board
	e. Broken drive gear or drive cap assembly	e. Replace drive gear or drive cap assembly
	f. Broken piston retainer	f. Replace drive cap assembly
	g. Broken main or regenerant piston	g. Replace main or regenerant piston
7. Control valve does not regenerate automatically when REGEN button is depressed and held	a. Transformer unplugged	a. Connect transformer
	b. No electric power at outlet	b. Repair outlet or use working outlet
	c. Broken drive gear or drive cap assembly	c. Replace drive gear or drive cap assembly
	d. Defective PC board	d. Replace PC board
8. Control valve does not regenerate automatically but does when REGEN button is depressed	a. By-pass valve in bypass position	a. Put bypass valve in normal operation position
	b. Meter connection disconnected	b. Connect meter to PC board
	c. Restricted/stalled meter turbine	c. Remove meter and check for rotation or foreign matter
	d. Defective meter	d. Replace meter
	e. Defective PC board	e. Replace PC board
	f. Set-up error	f. Check control valve set-up procedure
9. Time of day flashes on and off	a. Power has been out more than two hours, the transformer was unplugged and then plugged back into the wall outlet, the transformer plug was unplugged and then plugged back into the board or the NEXT and REGEN buttons were pressed to reset the valve.	a. Reset the time of day

