



AK and 3K Series Installation and Service Instructions (K200i Compatible 9011-XXX Models)

Possible Controls

K200i



OR

K60/KT60



OR

K30



OR

R30K

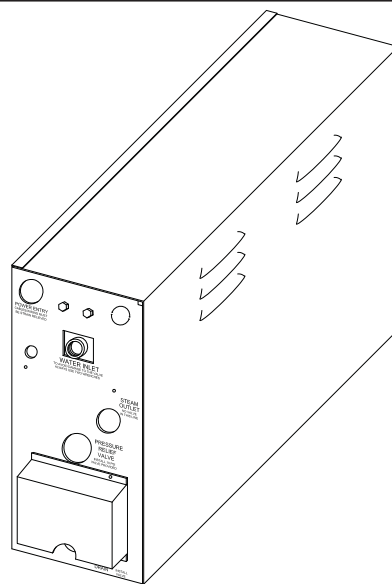

AK GENERATOR

AMEREC STEAMBATH GENERATORS (AK,3K and K200i Compatible 9011-XXX Models) Note: To be used with the K200i, K60, KT60, K30 or R30K Control.

SAVE THESE INSTRUCTIONS

READ ALL INSTRUCTIONS CAREFULLY BEFORE INSTALLATION.

POST "WARNING" LABEL OUTSIDE STEAMBATH FOR SAFETY WARNINGS. REQUIRED POSTING ON DOOR OF STEAM ROOM OR ADJACENT TO DOOR FOR ALL COMMERCIAL INSTALLATIONS.

SECTION 1: GENERAL INFORMATION

AMEREC Steam Generators are listed by UL or NRTL Laboratory. The steam generators come assembled and ready for installation. Check that the size and rating of the generator is suitable for your application, refer to Steam Room Construction and Generator Sizing Guide (AMEREC document 4211-38).

IMPORTANT

An exhaust fan installed outside the steam room is strongly recommended to remove excess steam from the bathroom or shower area.

WARNING

Electrical grounding is required on all AMEREC Steam bath Generators.

All electrical supplies should be disconnected when servicing generator.

All wiring must be installed by a licensed electrical contractor in accordance with local and national codes.

All plumbing must be installed by a licensed plumber in accordance with all applicable local and national codes.

AK series generators are for indoor use only.

AK series generators are not for space heating purposes.

Be certain that steam bath enclosures are properly sealed to avoid water damage from escaping steam. It is recommended that 100% silicone caulk be used to seal all pipes and fittings. Steam must be prevented from escaping into the wall cavity.

Never shut off the water to a steam generator that is in use.

Electric Shock Hazard - High voltage exists within this equipment. There are no user serviceable parts in this equipment.

WARNING

REDUCE THE RISK OF OVERHEATING AND SCALDING

1. Exit immediately if uncomfortable, dizzy or sleepy. Staying too long in a heated area is capable of causing overheating.
2. Supervise children at all times.
3. Check with a doctor before use if pregnant, diabetic, in poor health or under medical care.
4. Breathing heated air in conjunction with consumption of alcohol, drugs or medication is capable of causing unconsciousness.

CAUTION! Do not contact steam head. Stay at least 12" away from hot steam escaping from the steam outlet.

REDUCE THE RISK OF SLIPPING AND FALL INJURY

Use care when entering or exiting the steam room, floor may be slippery.

NOTE: For additional safety instructions, see owner's manual.

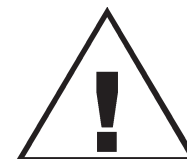

Table of Contents

| <u>Section</u> | <u>Description</u> | <u>Page</u> |
|-----------------------|---------------------------------------|--------------------|
| | Important Safety Instructions | 3 |
| 2 | Select Mounting Location | 5 |
| 4 | Mounting the Generator | 5 |
| 4.5 | Water Quality Requirements | 5 |
| 5 | Plumbing Instructions | 7 |
| 6 | Wiring Instructions | 8-10 |
| 6 | Celsius and 24 Hour K60/KT60 Settings | 10 |
| - | Electrical Information Chart | 9 |
| 7 | Operational Test | 10 |
| 8 | Service | 10-12 |
| 9 | Optional Modifications | 13 |
| 10 | Trouble Shooting | 13-14 |
| - | Exploded Parts Diagram | 15-16 |
| - | Wiring Diagram | 17-19 |

IMPORTANT SAFETY INSTRUCTIONS

1. READ AND FOLLOW ALL INSTRUCTIONS.
2. WARNING - To reduce the risk of injury, do not permit children to use this product unless they are closely supervised at all times.
3. WARNING - To reduce the risk of injury:
 - a. The wet surfaces of steam enclosures may be slippery. Use care when entering or leaving.
 - b. The steam head is hot. Do not touch the steam head and avoid the steam near the steam head.
 - c. Prolonged use of the steam system can raise excessively the internal human body temperature and impair the body's ability to regulate its internal temperature (hyperthermia). Limit your use of steam to 10 - 15 minutes until you are certain of your body's reaction.
 - d. Excessive temperatures have a high potential for causing fetal damage during the early months of pregnancy. Pregnant or possibly pregnant women should consult a physician regarding correct exposure.
 - e. Obese persons and persons with a history of heart disease, low or high blood pressure, circulatory system problems, or diabetes should consult a physician before using a steambath.
 - f. Persons using medication should consult a physician before using a steambath since some medication may induce drowsiness while other medications may affect heart rate, blood pressure and circulation.
4. WARNING - Hyperthermia occurs when the internal temperature of the body reaches a level several degrees above the normal body temperature of 98.6 degrees F. The symptoms of hyperthermia include an increase in the internal temperature of the body, dizziness, lethargy, drowsiness and fainting. The effect of hyperthermia include:
 - a. Failure to perceive heat:
 - b. Failure to recognize the need to exit the steambath:
 - c. Unawareness of impending risk:
 - d. Fetal damage in pregnant women:
 - e. Physical inability to exit the steambath: and
 - f. Unconsciousness.

WARNING - The use of alcohol, drugs or medication can greatly increase the risk of hyperthermia.

SAVE THESE INSTRUCTIONS

DIAGRAM 1

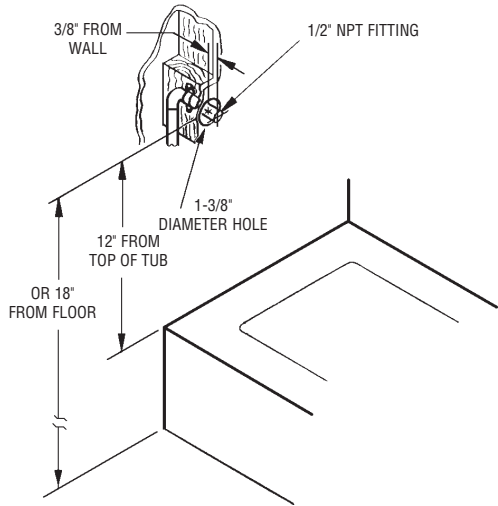

DIAGRAM 2

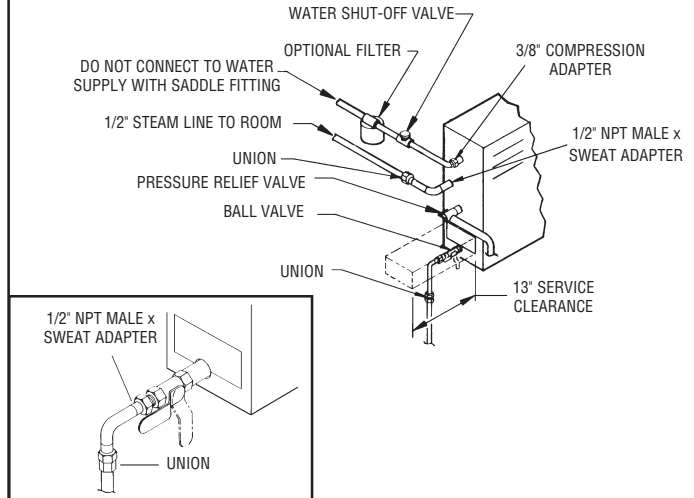

DIAGRAM 3

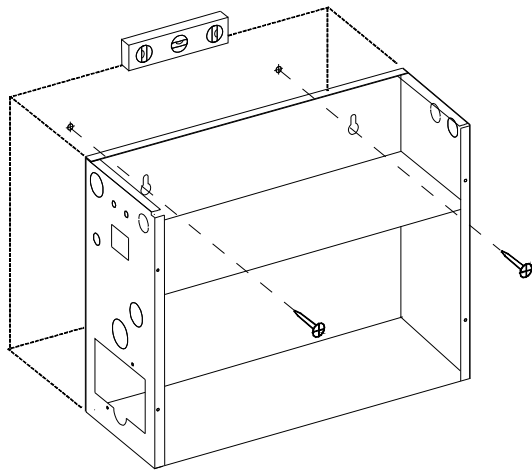
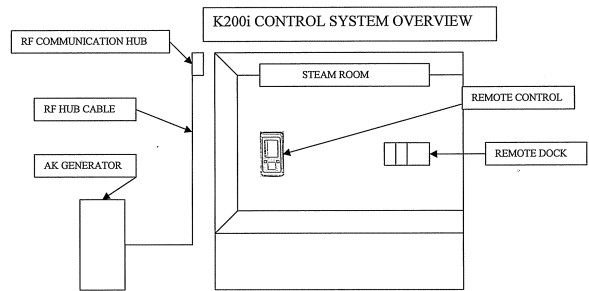

DIAGRAM 4



SECTION 2: SELECT MOUNTING LOCATION

SEE DIAGRAMS

The AMEREC steam generator can be hung on a wall or sit on its base. The best mounting location will satisfy all or most of the following:

1. The steam line should slope to allow condensation to drain. Condensation should drain into the steam room.
2. The steam line should be less than twenty feet long. Ten feet is preferred. Steam lines over twenty feet long should be insulated.
3. The mounting location should minimize the number of bends and elbows in the steam line.
4. The generator should be installed in a dry, well ventilated area. Suggested locations are under a vanity, in a closet, attic, crawl space or basement.
5. The location should provide clearance for service and element removal. See diagram 2.
6. The mounting location should allow for a drain hook up.
7. The generator must be mounted in a minimum 7 cubic foot space.
8. The generator should not be mounted in an area subject to freezing.

SECTION 4: MOUNTING THE GENERATOR

SEE DIAGRAM

Wall Mounting:

1. Note the location of the mounting holes on the back of the generator. The screws must set directly into studs or equivalent supports. Drill pilot holes on 16" centers and install the two #10 1½" screws provided.
2. Carefully hang the generator on the two screws. Tighten the screws. Replace the front cover. Secure the front cover with six screws.

Floor Mounting:

1. In general the width of the unit allows it to sit on a shelf, across the ceiling joists or on a floor. The generator must be restrained from moving. Normally the piping will provide adequate support. If not, additional support must be provided.
2. All floor installed generators must have provision for routine draining of the tank.

SECTION 4.5: Water Quality Requirements

The nature of a boiler or steambath generator requires testing of the feedwater to avoid potential high concentrations of impurities which can cause a deposit or scale to form on the internal surfaces. This deposit or scale can interfere with the equipments proper operation and even cause premature boiler or generator failure. Concentration of impurities is generally controlled by treating the feedwater and or "blowing down" the generator or boiler when it is not heating. The "blow down" process involves removing a portion of the tank water with high solid concentration and replacing it with makeup water.

To insure proper operation, the water supply should be tested prior to operating the equipment. There are several treatment processes which can be used if you have a problem with hard water. A local reliable water treatment company can recommend the appropriate treatment if required. The recommended feedwater quality is listed below.

Feedwater Quality

| | |
|-----------------------------|-----------------------------|
| Hardness, ppm | 10 - 30 (.5 - 1.75 gpg) |
| T-Alkalinity, ppm | 150 - 700 (8.75 - 40.8 gpg) |
| Silica Range, ppm | 15 - 25 (1.28 - 1.45 gpg) |
| PH (strength of alkalinity) | 10.5 - 11.5 |

IMPORTANT! Regular maintenance will help your steamer work properly for a long time. Check for leaks, loose or damaged wires, signs of corrosion and calcium build up in the tank on the level probe.

This is particularly important in areas with high calcium levels and other water quality problems. Calcium build can cause poor steamer performance and damage the heating elements!

WARNING

***Do not mount outdoors.
Protect from freezing.***

***Unit must be located as to allow
access for service.***

***The generator will not operate
properly, unless it is mounted level
with the arrows pointed up.***

DIAGRAM 5

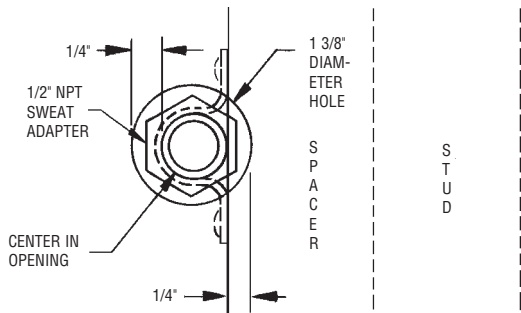

DIAGRAM 6

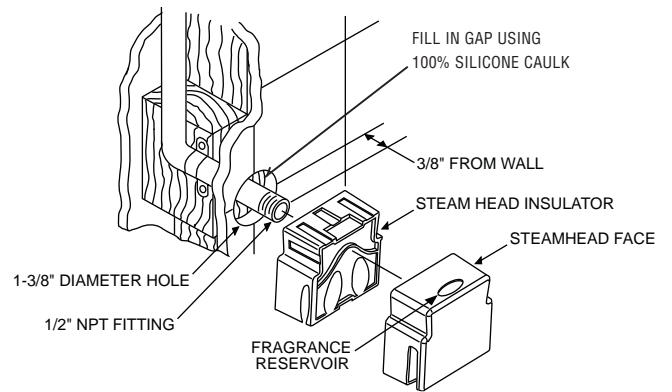

DIAGRAM 7

K30, K60, KT60 CONTROL

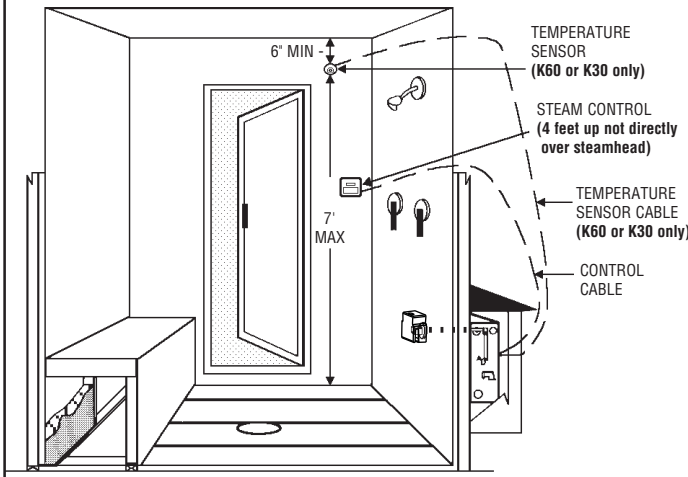

DIAGRAM 8

K30, K60, KT60 CONTROL

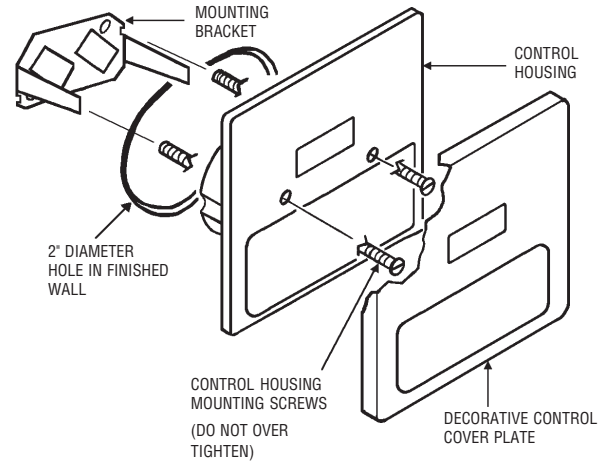

DIAGRAM 9

STEAM HEAD INSULATOR

K30, K60, KT60 CONTROL

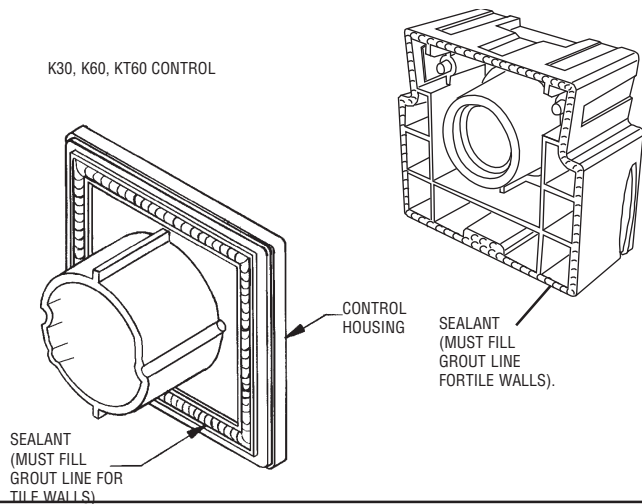
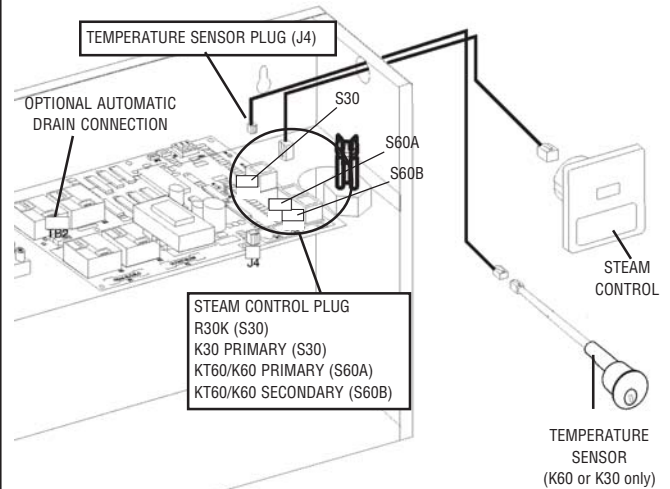

DIAGRAM 10



SECTION 5: PLUMBING INSTRUCTIONS

SEE DIAGRAMS

All plumbing shall be installed by a licensed plumber and conform with local & national codes.

Materials (locally available):

- 3/8" O.D. copper tube for the water supply to the generator.
- 3/8" water supply shut-off valve.
- 3/8" supply valve housing and filter (optional depending on local water conditions).
- 3/8" O.D. compression to 3/8" male NPT adapter.
- 1/2" copper sweat unions. (2)
- 1/2" copper pipe for the tank drain.
- 1/2" copper pipe and 1/2" female NPT sweat adapter for the steam line between the generator and the steam room.
- 3/4" copper pipe, fittings, and a sweat union for the Pressure Relief Valve drain.
- Tube DAP 100% silicone caulk.
- Rectorseal No. 5 pipe compound.

1. INSTALL WATER LINE

IMPORTANT

Maximum recommend input water pressure not to exceed 100 PSI.

Run 3/8" copper tube between the nearest cold water line and the WATER INLET fitting on the generator. Locate a shut-off valve near the generator. Connect this line to the generator with a 3/8" compression adapter. When tightening this fitting always use two wrenches so there will be no strain on the water inlet valve.

IMPORTANT

If the generator is mounted in a place difficult for the home owner to access, the water supply shut-off valve should be located where it can be quickly accessed in an emergency.

IMPORTANT

Do not use a saddle valve or saddle fitting for the water shut-off valve.
Flush water supply line before final hookup.

2. INSTALL STEAM LINE

A. At the generator: Install a 1/2" male NPT sweat adapter directly into the tank. Install a 1/2" union in the steam line.

B. Run the 1/2" copper steam line from the generator to the steamroom. Refer to SECTION 2: SELECT MOUNTING LOCATION.

C. The steam line should enter the steam room 18" above the floor or at least 12" above a tub rim or ledge. See diagram 1.

D. At the steam room: Drill/prepare a 1-3/8" hole for the steam line entry. Center the 1/2" copper steam pipe in the 1-3/8" hole. See diagram 5.

- Terminate the steam line with a 1/2" NPT male adapter. Stub the line out into the room 3/8" from the finished surface.
- Secure the steam line to a structural member.

IMPORTANT

If the steam line is in an area where the temperature will be below 40 degrees Fahrenheit or if the line is more than 20 feet long, best results can be obtained by insulating the steam pipe.

3. INSTALL STEAM HEAD INSULATOR: Fill in gap (using 100% Silicone caulk between steam pipe and finished wall surface at point of entry (see diagram 5). Apply silicone caulk to the finished wall side of the steam head insulator (see diagram 9) and screw on hand tight until it is flush with the wall with the opening pointing down. If a hand tight fit does not align with the opening pointing down, use teflon tape on the steam line threads to adjust the fit.

4. INSTALL STEAM HEAD FACE: Slide the steam head face onto the insulator until it rest firmly against the finished wall. Tighten the hex head screw underneath the steam head to secure it in place with the allen wrench provided. The steam head should be level with its fragrance reservoir at the top. See diagram 6.

IMPORTANT

Check all of the standard fixtures in the steam room. All fixture penetrations must be sealed with 100% silicon caulk to avoid moisture damage within walls.

5. INSTALL PRESSURE RELIEF VALVE

Install the pressure relief valve into its port on the generator. The pressure relief valve outlet must drain in accordance with local and national codes.

6. INSTALL DRAIN VALVE

Install 1/2" NPT male sweat adapter directly into the tank as shown in diagram 2. Install a 1/2" union. Run a 1/2" copper drain line to a gravity flow drain. Do not run the drain uphill. The drain must be connected in accordance with local and national codes. See diagram 2.

WARNING

Do not connect the overpressure device output into the steam line.

Do not connect the drain valve into the steam line.

**Do not mount outdoors.
Protect from freezing.**

Unit must be located as to allow access for service.

The generator will not operate properly, unless it is mounted level with the arrows pointed up.

Do not put a shut off valve in the steam line. Avoid traps and valleys where water could collect and cause a steam blockage. The hot steam line must be insulated against user contact.

Centering the steam pipe is critical in rooms made of plastic, acrylic, resin, fiberglass or similar materials.

Allowing the steam pipes to touch materials not rated for 212 degrees Fahrenheit or higher will result in damage to these materials.

Do not install the steam head near bench(es) or where steam may spray or where condensation will drip on the user as this will present a scald hazard.

The steam pipe entry and any other entry into the steam room must be caulked to avoid damage caused by steam leakage into the wall.

SECTION 6: WIRING INSTRUCTIONS (Dependent on Control Selected)
SEE ELEC. INFO. CHART AND WIRING DIAGRAM
1. K30, K60, KT60, R30i CONTROL CABLE ROUGH-IN

The low voltage control can be mounted **up to 25 feet** from the generator either inside or outside the steam room for the K30, K60 or R30K control but with a built in temperature sensor, the **KT60 must be mounted inside the steam room**, also see #6 optional secondary generator control. String the 25' cable from the control location through 1/2" holes in the wall studs or ceiling joists to the generator. Note: Do not staple through or damage cable. Use factory supplied cables only. Optional for tile rooms, a 2 gang rough-in box may be installed at the desired control mounting location. A mounting plate with proper diameter hole is included with the control kit. Tile up to the hole in mounting plate as indicated in diagram 13 or 14.

1A. K200i STEAM CABLE ROUGH-IN

There is only one 25' cable to install with the K200i control system for the RF Communication Hub which should be mounted high on a wall near the steam room or above the steam room. The RF hub relays signals from the K200i remote and dock to the generator but does not need to be in direct line of site with these items. (see diagram #4)

2. TEMPERATURE SENSOR CABLE ROUGH-IN (REQUIRED FOR K60 OR K30 ONLY)

It is recommended that the sensor be mounted in the steam room 6" from the ceiling, but not directly over the steam dispersion head or more than 7 feet above the floor. String the sensor cable from the sensor location through 1/2" holes in the wall studs or ceiling joists to the generator location. Leave 12" of slack at the sensor location. Note: Do not staple through or damage cable. Use factory supplied cables only.

3. ELECTRICAL ROUGH-IN

Size wire for the generator as indicated by the Electrical Information Chart on page 8. Use correct size and type to meet electrical codes. Leave 4 feet of slack wire at generator location for finish hookup. Connect the generator to a dedicated circuit breaker. A GFI device is not required by UL. One may be installed if required by local codes or the owner. A GFI device will tend to nuisance trip due to heater element aging.

4. ELECTRICAL FINISH Materials (locally available):
 - 3/4" Strain relief for supply wire.

- A.** Route the copper supply wire with appropriate strain relief through the hole marked POWER ENTRY.
- B.** Connect the supply wires to terminals marked L1 and L2.
- C.** Connect the ground to the ground lug (green screw).

5. INSTALL GENERATOR CONTROL (K30, K60, KT60)

The low voltage controls can be mounted directly to a finished wall either inside or outside the steam room with the exception of the **KT60 control which must be mounted inside the steam room**. Using a 2" hole saw, drill a hole in the finished wall where the control is to be mounted (the control cable should already be roughed-in to this location). With the decorative cover removed from the control switch assembly, insert the two control mounting screws through the control housing (may need to punch through skinned holes) and screw 1/4" into the mounting bracket. Locate the control cable and plug it into the back of the control housing. See diagram 8. Run a bead of 100% silicon caulk in-between the 2 ridges around the perimeter on the back of the control housing. See diagram 9. Insert the mounting bracket into the wall cavity by first pushing with the control housing and then with a hard flat surface on the control housing mounting screws which extend out through the control face. Once the mounting bracket has been inserted into the finished wall, center the control and tighten the mounting screws to draw the control housing securely against the finished wall. Do not over tighten the mounting screws. Install the decorative cover plate by sliding the top of the cover plate over the tab on the top of the control housing and pushing on the bottom of the cover plate to complete the snap fit. See diagram 11. Route the generator end of the control cable through the generator hole marked CONTROL WIRING ENTRY using the strain relief provided. Plug the control cable into the connector on the printed circuit board assembly. Insert cable into connector S30 if a K30 control is used or connector S60A if a K60 or KT60 control is used. See diagram 10.

5A. INSTALL GENERATOR CONTROL (R30K)

The low voltage control can be mounted directly to a finished wall either inside or outside the steam room. Using a 1-3/4" hole saw, drill a hole in the finished wall where the control is to be mounted (the control cable should already be roughed-in to this location). Locate the control cable, pull it out through the 1-3/4" hole and plug the connector on the back of the control housing. Run a bead of 100% silicone caulk around the perimeter on the back of the control housing. See diagram 13. Insert the control into the wall cavity.

5B. INSTALL GENERATOR CONTROL (K200i)

See K200i Installation and Owners Manual for installation instructions.

WARNING

The pressure relief valve must be installed in such a fashion that the risk of scalding is reduced to a minimum. Draining the pressure relief valve into the steam room may present a scald hazard.

Boiling water may be discharged from the drain. Proper precaution should be taken to insure safety.

Draining the tank into the steam room may present a scald hazard and/or damage materials used to construct the steam room.

Electrical shock hazard - Disconnect all electrical power before servicing the generator. All wiring should be installed by a licensed electrical contractor in accordance with local and national codes.

The generator is designed for hookup with copper wire only.

DIAGRAM 11

K60/KT60/K30 CONTROL

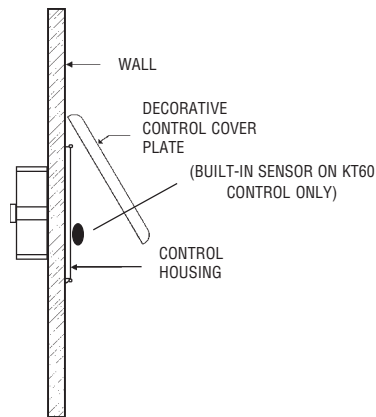
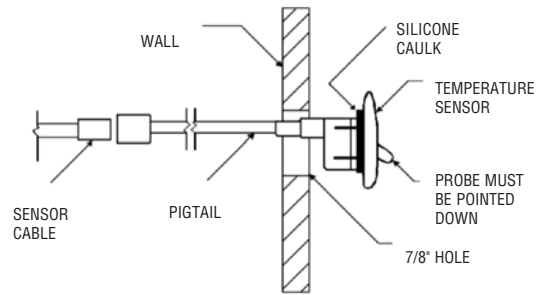

DIAGRAM 12

TEMPERATURE SENSOR USED WITH K60 OR K30 CONTROL ONLY



ELECTRICAL INFORMATION CHART

| STEAM GENERATOR MODEL NO. | AC VOLTAGE | PHASE | NOMINAL WATTAGE | | NOMINAL AMPERAGE | | UL RECOMMENDED PROTECTIVE DEVICE | | RECOMMENDED MINIMUM COPPER SUPPLY WIRE* |
|---------------------------|------------|-------|-----------------|--------|------------------|-----------|----------------------------------|-------|---|
| | | | @208 | @240 | @208 | @240 | @208 | @240 | |
| AK4 | 208 / 240 | 1 | 3,000 | 4,000 | 14.5 | 17.0 | 20 | 25 | 10-2 W/G |
| AK5 | 208 / 240 | 1 | 3,750 | 5,000 | 18.0 | 21.0 | 25 | 30 | 10-2 W/G |
| AK6 | 208 / 240 | 1 | 4,500 | 6,000 | 21.7 | 25.0 | 30 | 35 | 8-2 W/G |
| AK7 | 208 / 240 | 1 | 5,250 | 7,000 | 25.3 | 29.0 | 35 | 40 | 8-2 W/G |
| AK8.5 | 208 / 240 | 1 | 6,375 | 8,500 | 30.7 | 35.5 | 45 | 50 | 6-2 W/G |
| AK10 | 208 / 240 | 1 | 7,500 | 10,000 | 36.1 | 41.5 | 50 | 60 | 6-2 W/G |
| AK12 | 208 / 240 | 1** | 9,000 | 12,000 | 28.8/14.4 | 33.3/16.7 | 40/20 | 50/25 | 6-2/10-2 W/G |
| AK14 | 208 / 240 | 1** | 10,500 | 14,000 | 32.5/18.0 | 37.5/20.8 | 50/25 | 50/30 | 6-2/10-2 W/G |
| 3K8 | 208 | 3 | 7,900 | - | 21.9 | - | 30 | - | 10-3 W/G |
| 3K10 | 208 | 3 | 10,100 | - | 28.1 | - | 35 | - | 8-3 W/G |
| 3K12 | 208 | 3 | 11,300 | - | 31.3 | - | 40 | - | 8-3 W/G |
| 3K14 | 208 | 3 | 14,500 | - | 40.2 | - | 50 | - | 6-3 W/G |

* Observe wire sizes for 208 VAC installations. 208 VAC wired units must be supplied with a minimum of 195 VAC while operating (heating). Unit is rated for copper wire only. All wire is UL approved 300V 75 deg. C minimum unless otherwise specified. ** Single phase AK12 & AK14 require two separate line feed circuits.

DIAGRAM 13

R30K ROUGH-IN

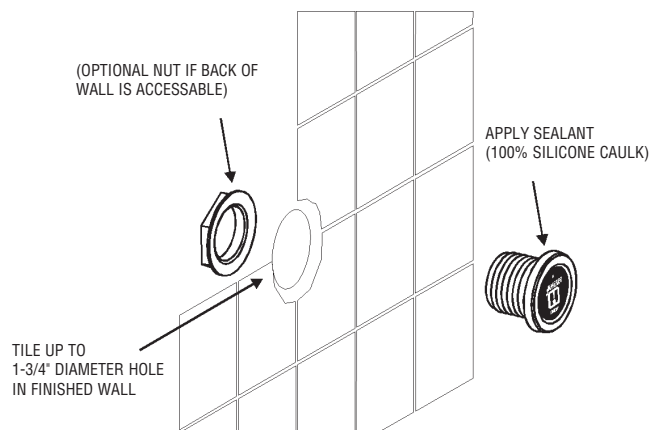
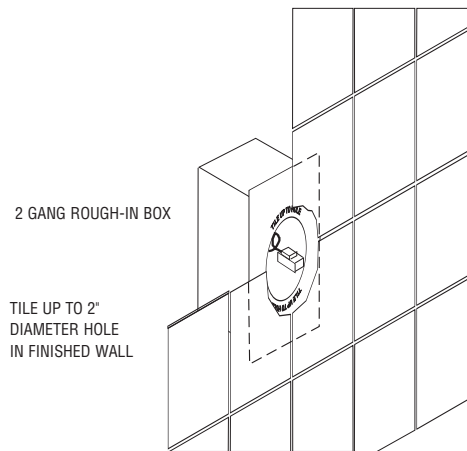

DIAGRAM 14

K30, K60, KT60 ROUGH-IN



SECTION 6: WIRING INSTRUCTIONS (continued)

SEE DIAGRAM

6. OPTIONAL SECONDARY GENERATOR CONTROL

As an option, a second K60 control can be installed with an AK generator to provide ON/OFF control both inside and outside the steam room. The second control should be installed as described in paragraphs 1 & 5, with the second control cable plugged into connector S60B for the K60 Control on the printed circuit board assembly. See diagram 10.

7. INSTALL TEMPERATURE SENSOR (REQUIRED FOR K60 OR K30 ONLY)

The temperature sensor should be mounted 6" below the ceiling, inside the steam room, but not directly over the steam dispersion head or more than 7 feet above the floor. Using a 7/8" hole saw, drill a hole in the finished wall where the sensor is to be mounted (the sensor cable should already be roughed-in to this location). Locate the sensor cable, pull it out through the hole and plug it into the temperature

sensor. It is best to tape the sensor and cable connection together to avoid disconnection inside the wall. Apply silicon caulk as shown in diagram 12 and insert the sensor in the hole. Make sure that the sensor probe is pointing down once installed. Tape the sensor in place while the silicone hardens. Route the generator end of the sensor cable through the generator hole marked CONTROL WIRING ENTRY using the control cable strain relief. Plug the sensor cable into the connector marked J4 on the printed circuit board assembly. See diagram 10

8. OPTIONAL CELSIUS OR 24 HOUR OPERATION.

For installations with K60 or KT60 controls, the operation can be changed from Fahrenheit to Celsius or 60 minute operation to 24 hours operation by setting the jumpers as shown below on the generator printed circuit board.

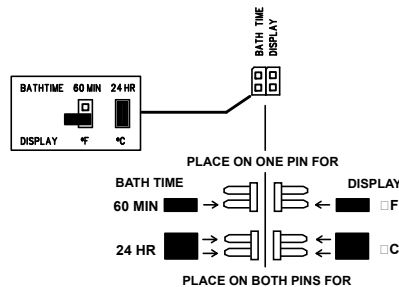

SECTION 7: OPERATIONAL TEST

1. Assure power and water are on.
2. Press the ON/OFF. The control should light-up.
3. Allow 10 minutes for the steam to start.
4. Once the steam starts, press the ON/OFF. The steam should stop; there shouldn't be any water flow. The control should not be lit-up.
5. Press the ON/OFF. The control should light up.
6. Within one minute the unit should again produce steam. It should call for water once every two minutes or more depending on its power rating. It's normal for the flow of steam out the steam head to slow for up to 10 seconds each time the unit calls for water.
7. The unit will shut down automatically in 30 minutes if the "R30K or K30" Control is used, or up to 60 minutes if the K200i, K60 or KT60 Control is used. When the time runs out the steam will stop and there should not be any water flow. The control should not be lit.
8. If the unit does not operate as described above, refer to SECTION 9: TROUBLESHOOTING GUIDE.

THE UNIT IS NOW READY FOR OPERATION.

SECTION 8: SERVICE

SEE ELECTRICAL INFORMATION CHART

1. DESCRIPTION OF AMEREC AK SERIES GENERATOR

The AK series is one of AMEREC's high performance line of steam generator products.

The Printed Circuit Assembly (the "PCA") provides the basic functions necessary to produce steam. The PCA controls makeup water, provides a water level permissive for powering the elements and provides raw DC power for the system.

The PCA also provides regulated non-interruptible 5.0 VDC power for the generator control and temperature sensor. It provides the interface circuitry between the control and the PCA, provides the room temperature control loop, power switching for "soft steam" and a fixed 30 minute steam bath timer or adjustable 60 minute timer.

2. MAINTENANCE OF AK SERIES STEAM GENERATORS

- **VISUAL INSPECTION** - Whenever the generator is opened, inspect for any evidence of water leaks. Inspect the wiring for any evidence of overheating. Check all electrical connections for tightness.

(continued on page 12)

WARNING

Electrical shock hazard - Disconnect all electrical power before servicing the generator. All wiring should be installed by a licensed electrical contractor in accordance with local and national codes.

For continued safe operation use factory authorized replacement elements only.

DIAGRAM 15

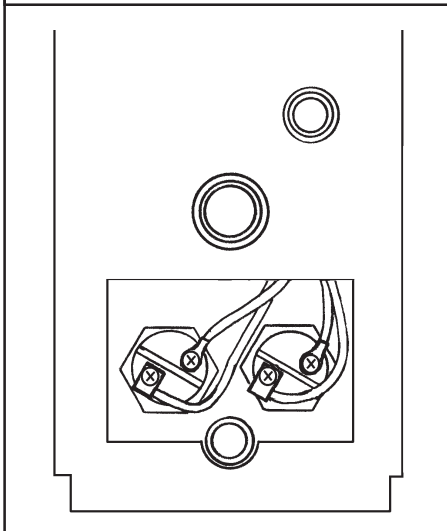

DIAGRAM 16

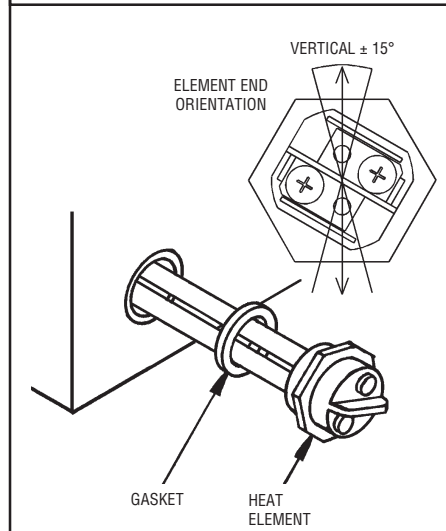

DIAGRAM 17

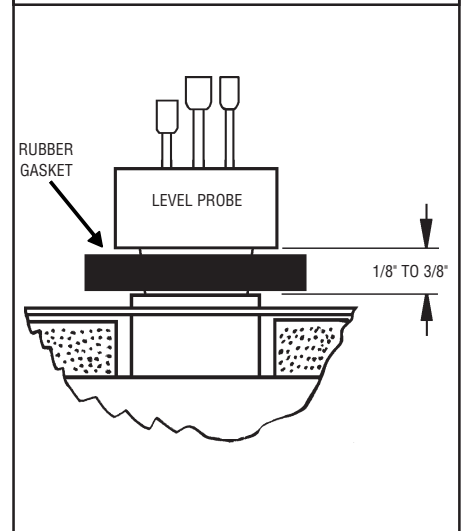

DIAGRAM 18

This diagram intentionally left blank.

DIAGRAM 19

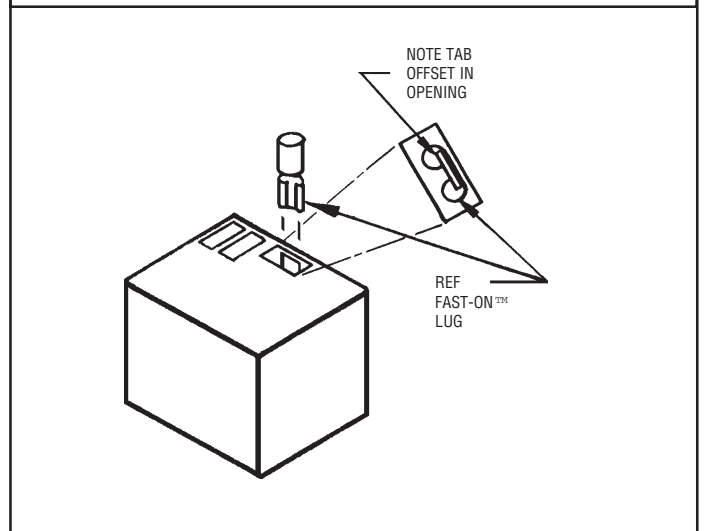
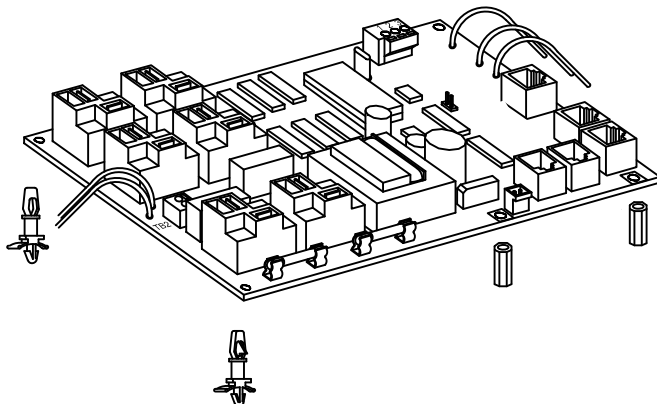
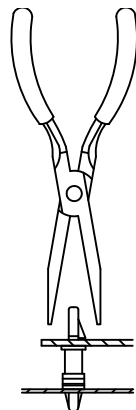

DIAGRAM 20

TO REMOVE PCA:

REMOVE SCREWS FROM METAL STANDOFFS
THEN CAREFULLY LIFT UP ON CIRCUIT BOARD NEAR EACH
NYLON MOUNTING POST. USE NEEDLE NOSE PLIERS TO
SQUEEZE AND RELEASE LOCKING TAB ON MOUNTS AS
NEEDED.



SECTION 8: SERVICE (continued)

SEE DIAGRAMS

- **FLUSH TANK** - Flush monthly, or more often, depending on local water conditions.

- **FLUSHING PROCEDURE:**

1. The generator should be cool.
2. Press the ON/OFF. The control should light.
3. Open the manual drain valve.
4. The unit will drain without heating the water.
5. Allow the water to run for a full 10 minutes, then press the ON/OFF. The control light should turn off.
6. Allow the unit to drain completely. When the water stops, close the manual drain valve.

3. REPAIR OF AK SERIES GENERATORS

A. ELEMENT REPLACEMENT:

Disconnect power from the unit. Drain the tank. Open the front and HEATING ELEMENT ACCESS covers. Note the wire connections. See diagram 15. Remove the element wires. Using a hot water element socket, remove the element. To install a new element, mount a new element gasket on the element. Clean the element port and add a light coat of Rectorseal No. 5 pipe thread compound to the threads. Insert and hand tighten the element-gasket combination. Notice the element end orientation as shown in diagram 16. Tighten the element until the orientation is the same as diagram 16, $\pm 15^\circ$. The gasket should be set and tight but not deformed to a rounded or bulbous appearance. If the drain valve was removed reinstall it. Reconnect the wiring. Test the unit per SECTION 7: OPERATIONAL TEST. Check for leaks at the element. Replace the front cover and the HEATING ELEMENT ACCESS cover.

B. PRINTED CIRCUIT REPLACEMENT:

Printed circuit assembly (PCA) removal and replacement must be performed in the sequence described below. Any other method can damage the PCA.

IMPORTANT

The PCA's contain static sensitive devices. Static electricity may damage PCA's. Handle accordingly.

Disconnect power from the unit. Note and tag the positions of all wires that plug into the printed circuit assembly mounted relays. Remove all the wires from the relays. When removing these wires, pull on the connector, not the wire. Note the blue wire connected to the shortest of the triple pronged water level probe. Disconnect all three wires from the water level probe. Remove PCA from all seven standoffs by pinching the tops. When it is completely disconnected, it may be lifted out of the enclosure. See diagram 20. To install the board, reverse this procedure. Test the unit per SECTION 7: OPERATIONAL TEST.

IMPORTANT

The blue wire connected to "L" on the PCA must be connected to the shortest of the three level probes.

C. WATER SOLENOID REPLACEMENT:

Disconnect power from the unit. Turn the water supply OFF. Disconnect the water supply from the water solenoid valve. Remove the front cover. Remove the two blue wires from the water solenoid valve. Rotate the self-tightening hose clamp so it can be loosened with a pair of pliers. Squeeze the clamp and move it down towards the shelf and off the valve outlet tube. Remove the two 1/4" - 20 hex head bolts and lock washers that attach the valve to the chassis. Pull the valve off the rubber fill hose. To install the valve, reverse these instructions. Test the unit per SECTION 7: OPERATIONAL TEST.

D. LEVEL PROBE REPLACEMENT:

Disconnect power from the unit. Remove the front cover. Note where the blue wire is connected to the triple pronged water level probe. Disconnect all three wires from the water level probe. Using a 1-1/4" box wrench, remove the level probe. Install a new level probe. Use Teflon Tape on threads of probe if required. Tighten until the bottom of the plastic nut is 1/8" to 3/8" inch above the top of the port. See diagram 17. Reattach the three wires. Test the unit per SECTION 7: OPERATIONAL TEST.

IMPORTANT

The blue wire connected to "L" on the PCA must be connected to the shortest of the three level probes.

IMPORTANT

The level probe may be extremely tight. Damage to the insulation or chassis may result unless the tank is properly blocked or supported during probe removal or installation. It may be necessary to completely disconnect and disassemble the generator.

WARNING

All electrical supplies should be disconnected when servicing generator.

Electrical Shock Hazard. PCA's have exposed 208 / 240 VAC on them. Disconnect 208 / 240 VAC power to the generator before servicing.

The relays may be damaged if the correct orientation of the connectors is not observed. See diagram 19.

SECTION 9: OPTIONAL MODIFICATIONS

The AK Generator design may incorporate several modification options. Options such as automatic tank draining and others are available. Please call AMEREC at 1-800-331-0349 for instructions and availability of these options.

SECTION: 10 TROUBLE SHOOTING GUIDE

There are no user serviceable parts in the Generator. All repair should be performed by a qualified service person. For additional assistance or the factory authorized service person nearest you call Steam Technical Support at 1-800-363-0251. The Trouble Shooting Guide below is meant as a general aid only. Follow ACTION TO BE TAKEN in order until the problem is resolved. Where replacements or repairs are indicated, see the appropriate paragraph of SECTION: 8 SERVICE.

| SYMPTOMS | PROBABLE CAUSES | ACTION TO BE TAKEN |
|--|---|--|
| <p>Control wont turn "On" (Control light off) KT60, K60, K30, R30K & R30i Controls</p> <p>Note: Control Cables must be correctly plugged in <i>before</i> power is turned on.</p> | <p>Improper power supplied. <i>or</i> Control improperly connected. <i>or</i> "PCA" printed circuit assembly is faulty. <i>or</i> Control cable is faulty. <i>or</i> Control is faulty.</p> | <ol style="list-style-type: none"> 1. a. Make sure circuit breaker is "ON" and that 208V/240V is supplied. b. Using a voltmeter, check the voltage across the two fuses on the "PCA" printed circuit assembly. Voltage should be 208V/240V when measured fuse to fuse on left ends and fuse to fuse on right ends. fuse on left ends and fuse to fuse on right ends. If proper voltage is present across left ends but not right ends, one or more fuse is blown. c. Turn off Power to generator. Check fuses on the PCA. If the fuse(s) are blown, replace with 100mA SLO-Blow (F1) or 1A FAST-Blow (F2) If the fuse(s) blows again - Call Steam Technical Support. 2. a. Turn off Power to generator. b. Check control(s) installed per Section 6. Re-apply power and test operation. 3. Replace PCA printed circuit assembly - Call Steam Technical Support. 4. Replace control cable - Call Steam Technical Support. 5. Replace the control - Call Steam Technical Support. |
| <p>K200i Remote will not turn "SteamBath On" Remote "On" Icon selected and Remote displays Red "X" (over 5mins.) <i>and</i> K200i Dock will not turn "SteamBath On" Dock On/Off button pushed. Dock light comes "On" while button pushed but light does not begin blinking within 5 minutes after button is released.</p> | <p>Improper power supplied <i>or</i> Hub or Hub Cable not properly connected. <i>or</i> Hub cable is faulty. <i>or</i> K200i Communication System has experienced "Communication Interference" <i>or</i> K200i Communication System is faulty.</p> | <ol style="list-style-type: none"> 1. Follow preceding "ACTION TO BE TAKEN" steps 1. thru 2. 2. Turn off Power to generator.. Check to make sure hub cable is plugged into Pca J9 port labeled "Wireless Hub" and Hub is mounted within communication range of Dock & Remote Control (See Hub Mounting instructions) located in the K200i Control Installation & Owners Manual for AK & 3K Generators. Turn on power to generator, wait 3 minutes for communication to be established. If Red "X" is no longer present, communication has been established. Test for proper operation. 3. Replace Hub cable. 4. See K200i Control Installation & Owners Manual for AK & 3K Generators (Section 4 RF Hub Mounting) 5. Call Steam Technical Support |
| <p>Control "Off" Water won't shut off and runs out steam head.</p> | <p>Water solenoid valve is stuck open <i>or</i> "PCA" printed circuit assembly is faulty.</p> | <ol style="list-style-type: none"> 1. Turn off power to generator. If the water stops, go to step 3. 2. a. Remove the water solenoid valve, disassemble, clean, re-assemble, and check for proper operation. b. Replace water solenoid valve - Call Steam Technical Support. 3. Replace the "PCA" printed circuit assembly - Call Steam Technical Support. |
| <p>Control "On" Water won't shut off and runs out steam head.</p> | <p>Connection between the blue water level probe wire and the water level probe is faulty. <i>or</i> Water Level Probes may need cleaning.. <i>or</i> Tank and Baffle may be clogged with scale and need cleaning. <i>or</i> "PCA" printed circuit assembly is faulty</p> | <ol style="list-style-type: none"> 1. Check that the blue & white wires are properly attached to the water level probe. Blue wire attaches to the shortest level probe, white to the highest probes. 2. Remove the blue wire from the water level (shortest) probe. Momentarily ground the blue probe wire to the steamer chassis and listen for a click. If the click noise is heard and the water valve shuts off, clean or replace the water level probe. Note: Also inspect the tank and baffle area for potential cleaning. Call Steam Technical Support. 3. If the click is not heard replace the "PCA" printed circuit assembly. Call Steam Technical Support. |
| <p>Control "On" Water won't shut off and runs out drain.</p> | <p>Drain valve not installed or not closed. <i>or</i> Auto drain valve not closing.</p> | <ol style="list-style-type: none"> 1. Check that drain valve is installed on the drain outlet and in the closed position. 2. Check that electric Auto drain valve is installed on the drain outlet. and valve wires are connected to drain terminal block on PCA in steam. 3. Check for 208V/240V to electric drain valve from PCA. 4. If voltage is not present then Call Steam Technical Support. |
| <p>Control "On" Unit won't fill with water. Tank drained.</p> | <p>No water supplied (turned off) <i>or</i> Plugged water solenoid valve <i>or</i> Water solenoid valve is faulty <i>or</i> "PCA" printed circuit assembly is faulty <i>or</i> Level probe is faulty.</p> | <ol style="list-style-type: none"> 1. Check for proper water supply (Supply valve "On"). Note: Drain valve must be closed to allow tank to remain full. 2. Remove the blue wire from the level probe. If the unit fills clean or replace the level probe. 3. Turn power off to generator. 4. At the water valve solenoid, slide back the blue connector enough to get the voltmeter probes on the solenoid terminals. Turn power & control back on. Measure the voltage across the solenoid terminals. If it is not 208V/240V, replace the printed circuit assembly. If 208V/240V is found proceed with steps 4 & 5. 5. Remove the water solenoid valve; disassemble, clean, reassemble, and check for proper operation. 6. Replace the water solenoid valve - Call Steam Technical Support. |

SECTION 10: TROUBLE SHOOTING GUIDE cont.

| SYMPTOMS | PROBABLE CAUSES | ACTION TO BE TAKEN |
|---|--|--|
| Control "On" Unit won't steam. Note: Steam lit steadily on K30 <i>or</i> Time/Temp. properly displayed on K60/KT60 <i>or</i> K200i Remote and Dock in "On" state with proper temperature displayed. | Unit has not filled completely. <i>or</i> Heating elements burnt out. <i>or</i> Level probe faulty. <i>or</i> "PCA printed circuit assembly is faulty. | 1. a. Turn the control "Off". b. Open the drain valve allowing tank to drain completely. c. Close the drain valve. d. Turn the control "On". e. Unit will begin filling, listen for a click noise. Within 20 seconds after click noise is heard, the water fill will shut off. This will indicate the tank is full. If the tank does not fill - See SYMPTOMS: "Unit won't fill up". 2. If the tank filled but the relay click was not heard, momentarily ground the two white water level probe wires to the steamer chassis. If the click noise is heard as probe wires are grounded, clean or replace the level probe. If the click is not heard replace the "PCA" printed circuit assembly. 3. After it has been determined that the tank was filled and the click noise was heard, remove the heating element access panel then Using a voltmeter, check the voltage between the two wires on each heating element or between the two element wires on each set of relays The voltage should be 208V/240V. If proper voltage is found, replace heating elements. Note: Also inspect the tank and baffle area for potential cleaning. Call Steam Technical Support. If proper voltage is not found, Call Steam Technical Support. |
| Control "On" KT60 / K60 displays "E001" | Temperature sensor not connected. <i>or</i> KT60 Faulty | 1. Check that the sensor cable is connected to J4 on the "PCA" printed circuit assembly. 2. Check the cable connection to the temperature sensor. 3. Replace sensor and/or cable - call Steam Technical Support. 4. Replace KT60 Call Steam Technical Support. |
| Control "On" KT60 / K60 displays "E002" | Temperature sensor. <i>or</i> Sensor cable shorted. <i>or</i> KT60 Faulty | 1. Check the sensor cable for damage from nail/staple puncture. 2. Check for moisture at sensor cable connections. 3. Check sensor cable ends for frayed/exposed wire strands. 4. Replace sensor and/or cable - Call Steam Technical Support. 5. Replace KT60 Call Steam Technical Support. |
| Control "On" KT60 / K60 displays ">>>" or "E055" | Steambath temperature over 130degs. <i>or</i> Sensor/cable faulty. <i>or</i> "PCA" printed circuit assembly is faulty. | 1. If bath is too hot, shut off circuit breaker - Call Steam Technical Support. 2. Treat as "E002" fault above. 3. Call Steam Technical Support. |
| Control "On" KT60 / K60 displays "E044" <i>and</i> Warm Start Control Flashes | Tank getting too hot. <i>or</i> Warm Start Temp. Sensor failure. <i>or</i> PCA failure | Call Steam Technical Support. |
| Control "On" KT60 / K60 displays "E007" <i>and</i> Warm Start Control Flashes | Open Warm Start sensor. | 1. Check to make sure that warm start sensor is firmly plugged into J5, located along the back edge of the PCA to the left of the green (3 position) terminal block. 2. Call Steam Technical Support. |
| Control "On" KT60 / K60 displays "E008" <i>and</i> Warm Start Control Flashes | Shorted Warm Start sensor | Call Steam Technical Support. |
| Control "ON" K30 light blinking. | Control improperly connected <i>or</i> Sensor/cable faulty. <i>or</i> Control Faulty. | 1. Check that the control cable is properly plugged in at the control and at the generator. K30 to S30 connector on the PCA. Turn off power supply. Wait one (1) minute then turn back on. Check for proper operation. If K30 is still "blinking", turn off power supply and Call Steam Technical Support. 2. Check sensor/cable as with K60 "E001" and "E002". 3. Replace the control - Call Steam Technical Support. |
| Control/Steamer won't turn "Off." KT60, K60, K30 R30K & R30i Controls. | Control is faulty. <i>or</i> "PCA" printed circuit assembly is faulty. | 1. Replace the control. Call Steam Technical Support. 2. Turn off the power to the generator, replace printed circuit assembly - Call Steam Technical Support. |
| Water continually sputters out of steam head. | Foaming contaminants in the water | 1. Flush tank 3 times. See section 8, flushing procedure. 2. Call Steam Technical Support. |
| Unable to adjust Time or Temp setting. K60/KT60 Controls. | Control faulty. <i>or</i> PCA" printed circuit assembly is faulty. | 1. Replace the control. Call Steam Technical Support. 2. Replace PCA - Call Steam Technical Support. |

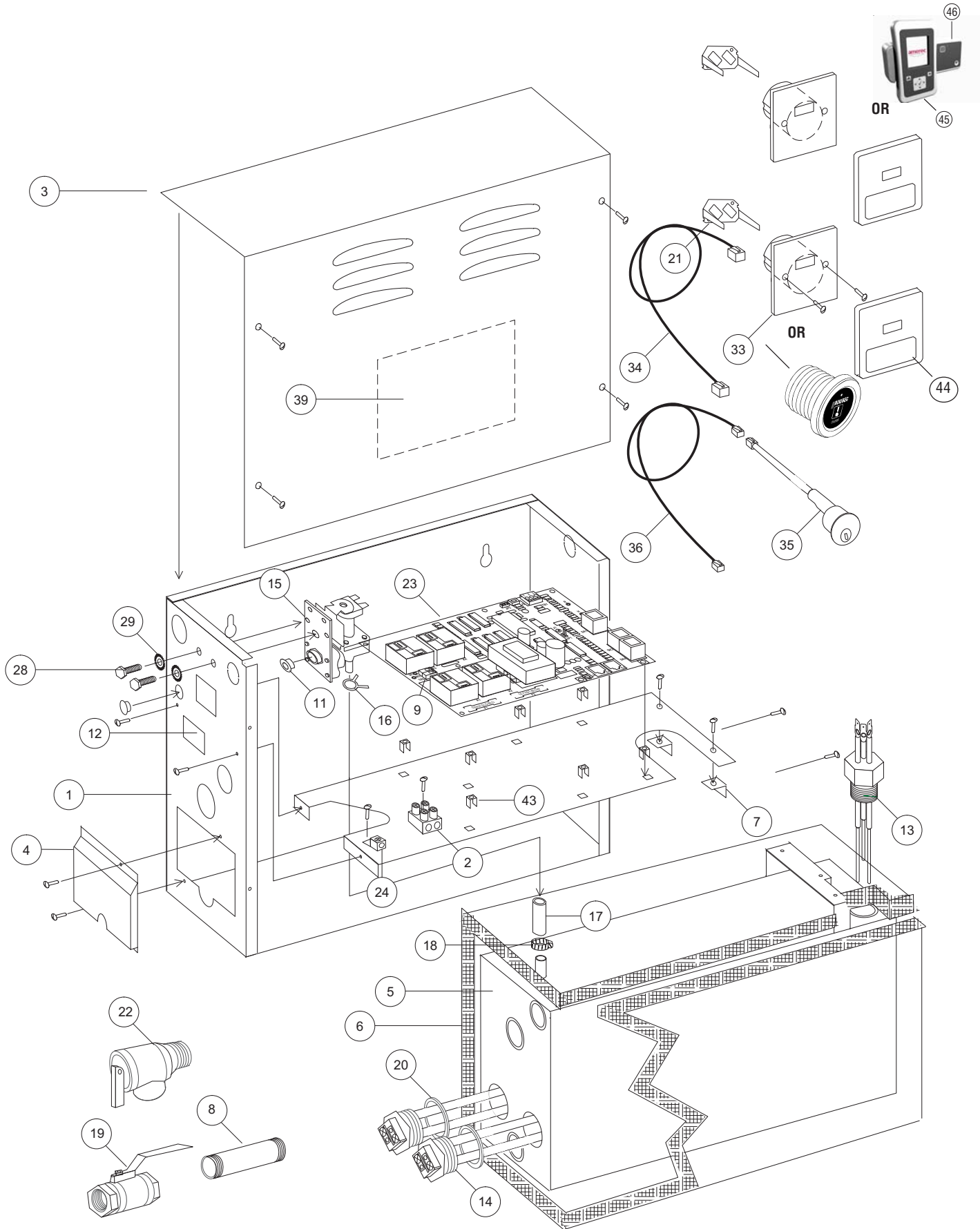

| NUMBER | PART NAME | DESCRIPTION |
|--------|---------------------|--|
| 1 | FRAME | CHASSIS |
| 2 | TERMINAL | POWER INPUT TERMINAL BLOCK |
| 3 | COVER | FRONT WITH WD LABEL |
| 4 | COVER | ELEMENT ACCESS |
| 5 | TANK | TWO ELEMENTS |
| 6 | INSULATION | BLANKET |
| 7 | BRACKET | L BRACKET |
| 8 | NIPPLE | DRAIN NIPPLE |
| 9 | TERMINAL | OPTIONAL AUTO FLUSH TERMINAL BLOCK |
| 11 | CAP | CAP, THREAD PROTECTOR |
| 12 | LABEL | UL RATING |
| 13 | PROBE | TRIPLE LEVEL |
| 14 | ELEMENT | REPLACEABLE ELEMENT |
| 15 | VALVE | WATER INLET |
| 16 | CLAMP | SELF-TIGHTENING |
| 17 | HOSE | WATER |
| 18 | CLAMP | AUGER |
| 19 | VALVE | MANUAL DRAIN |
| 20 | GASKET | ELEMENT |
| 21 | BRACKET | MOUNTING BRACKET |
| 22 | VALVE | PRESSURE RELIEF |
| 23 | PCA | PRINTED CIRCUIT ASSEMBLY, AK |
| 24 | LUG | GROUND |
| 28 | BOLT | 1/4-20 x 1/2" |
| 29 | WASHER | 1/4" LOCK |
| 33 | CONTROL HOUSING | CONTROL HOUSING K60, KT60 or KK30 |
| 34 | CABLE | CONTROL CABLE |
| 35 | SENSOR | TEMPERATURE SENSOR (K30 or K60 ONLY) |
| 36 | CABLE | TEMPERATURE SENSOR CABLE (K30 or K60 ONLY) |
| 37 | STEAM HEAD | DISPERSION HEAD (NOT SHOWN) |
| 38 | PLACARD | SAFETY (NOT SHOWN) |
| 39 | LABEL | WIRE DIAGRAM |
| 40 | FUSES | 15/100 SLO-BLO (NOT SHOWN) |
| 41 | FUSES | 3A SLO-BLO (NOT SHOWN) |
| 43 | STANDOFF | STAND OFF |
| 44 | COVERPLATE | DECORATIVE CONTROL COVER PLATE |
| 45 | REMOTE CONTROL | K200i REMOTE CONTROL |
| 46 | REMOTE CONTROL DOCK | REMOTE CONTROL DOCK |

PARTS AND / OR RETURNS:

• For assistance or parts ordering, please contact your local AMEREC Dealer or AMEREC at 1-800-331-0349. Please help us to serve you better by:

1. Identifying the problem by using the troubleshooting guide in this manual.

2. Read Number 12, the UL Ratings Label, to obtain your unit's model and code number.

• When ordering parts, please provide the number, description and quantity needed. When ordering wires or wire assemblies, please describe the wires by color, location and / or their connection points.

• Do not return any material to AMEREC without first contacting AMEREC for a Return Authorization Number. Freight must be prepaid to AMEREC.

2 ELEMENT SINGLE PHASE STEAM GENERATOR WIRING DIAGRAM

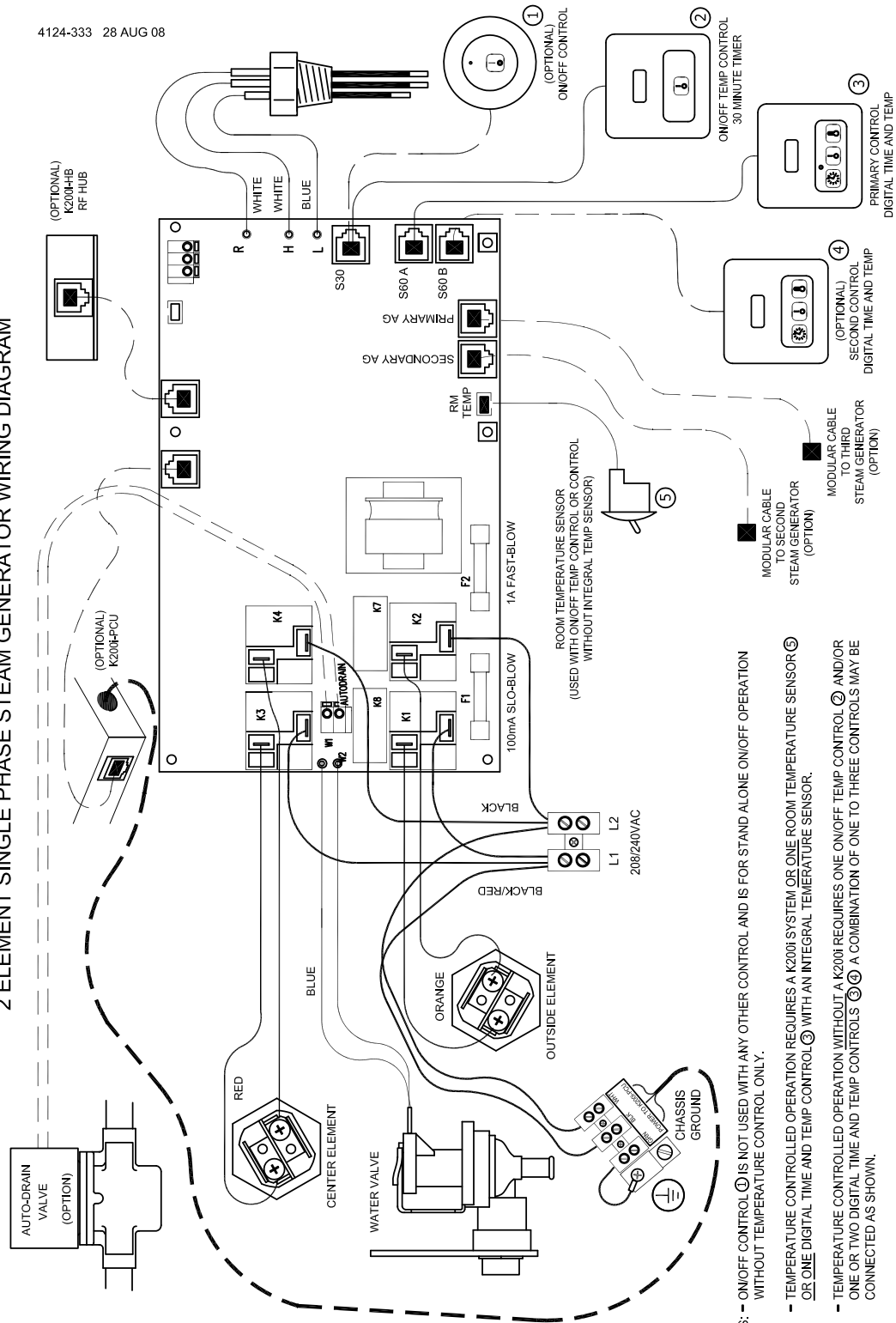

NOTES: - ON/OFF CONTROL ① IS NOT USED WITH ANY OTHER CONTROL AND IS FOR STAND ALONE ON/OFF OPERATION WITHOUT TEMPERATURE CONTROL ONLY.

- TEMPERATURE CONTROLLED OPERATION REQUIRES A K200i SYSTEM OR ONE ROOM TEMPERATURE SENSOR ② OR ONE DIGITAL TIME AND TEMP CONTROL ③ WITH AN INTEGRAL TEMPERATURE SENSOR.

- TEMPERATURE CONTROLLED OPERATION WITHOUT A K200i REQUIRES ONE ON/OFF TEMP CONTROL ① AND/OR ONE OR TWO DIGITAL TIME AND TEMP CONTROLS ③. A COMBINATION OF ONE TO THREE CONTROLS MAY BE CONNECTED AS SHOWN.

3 ELEMENT SINGLE PHASE STEAM GENERATOR WIRING DIAGRAM

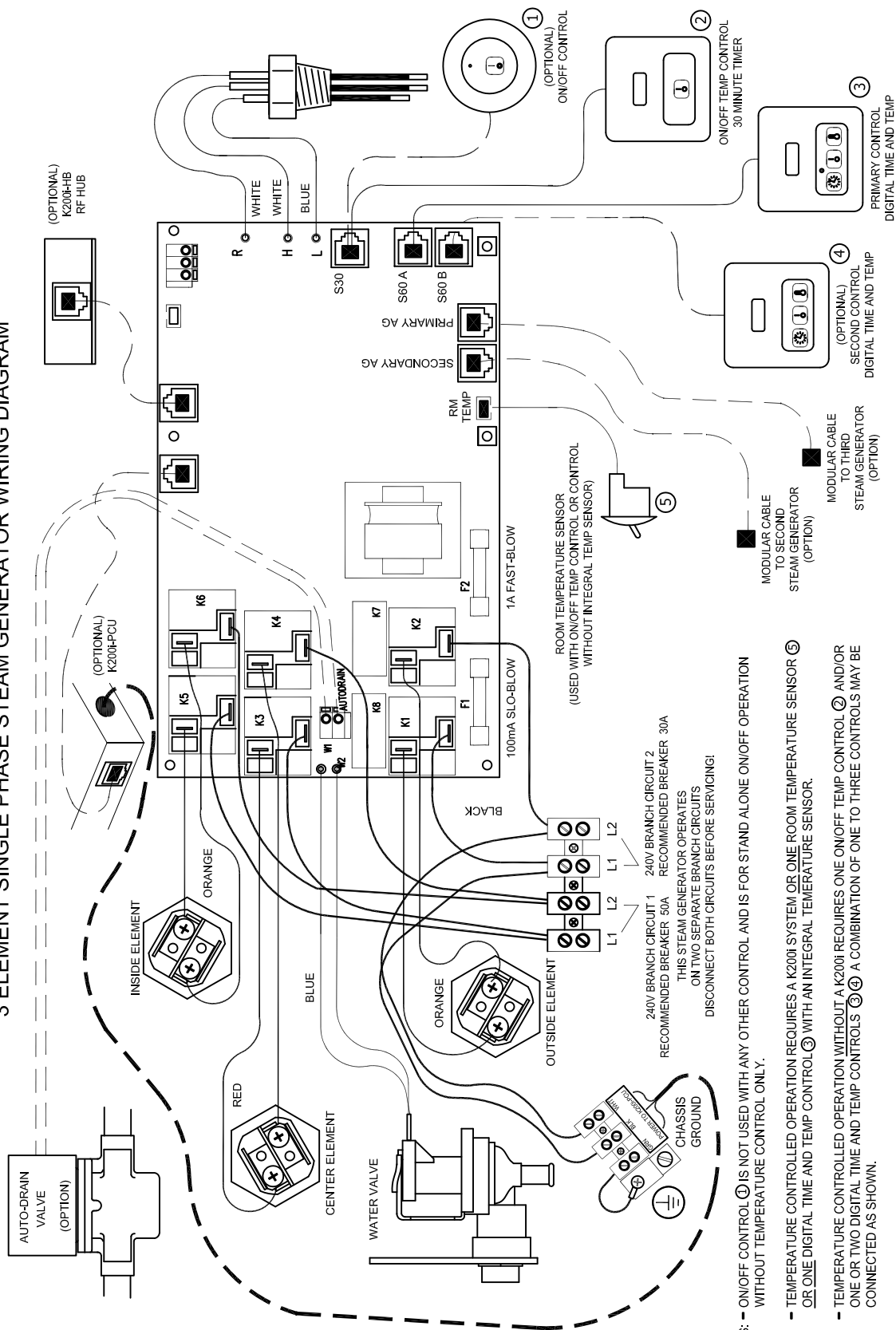

- NOTES:**
- ① IS NOT USED WITH ANY OTHER CONTROL AND IS FOR STAND ALONE ON/OFF OPERATION WITHOUT TEMPERATURE CONTROL ONLY.
 - TEMPERATURE CONTROLLED OPERATION REQUIRES A K200H SYSTEM OR ONE ROOM TEMPERATURE SENSOR ⑤ OR ONE DIGITAL TIME AND TEMP CONTROL ③ WITH AN INTEGRAL TEMPERATURE SENSOR.
 - TEMPERATURE CONTROLLED OPERATION WITHOUT A K200H REQUIRES ONE ON/OFF TEMP CONTROL ② AND/OR ONE OR TWO DIGITAL TIME AND TEMP CONTROLS ③④ A COMBINATION OF ONE TO THREE CONTROLS MAY BE CONNECTED AS SHOWN.

3 ELEMENT THREE PHASE STEAM GENERATOR WIRING DIAGRAM

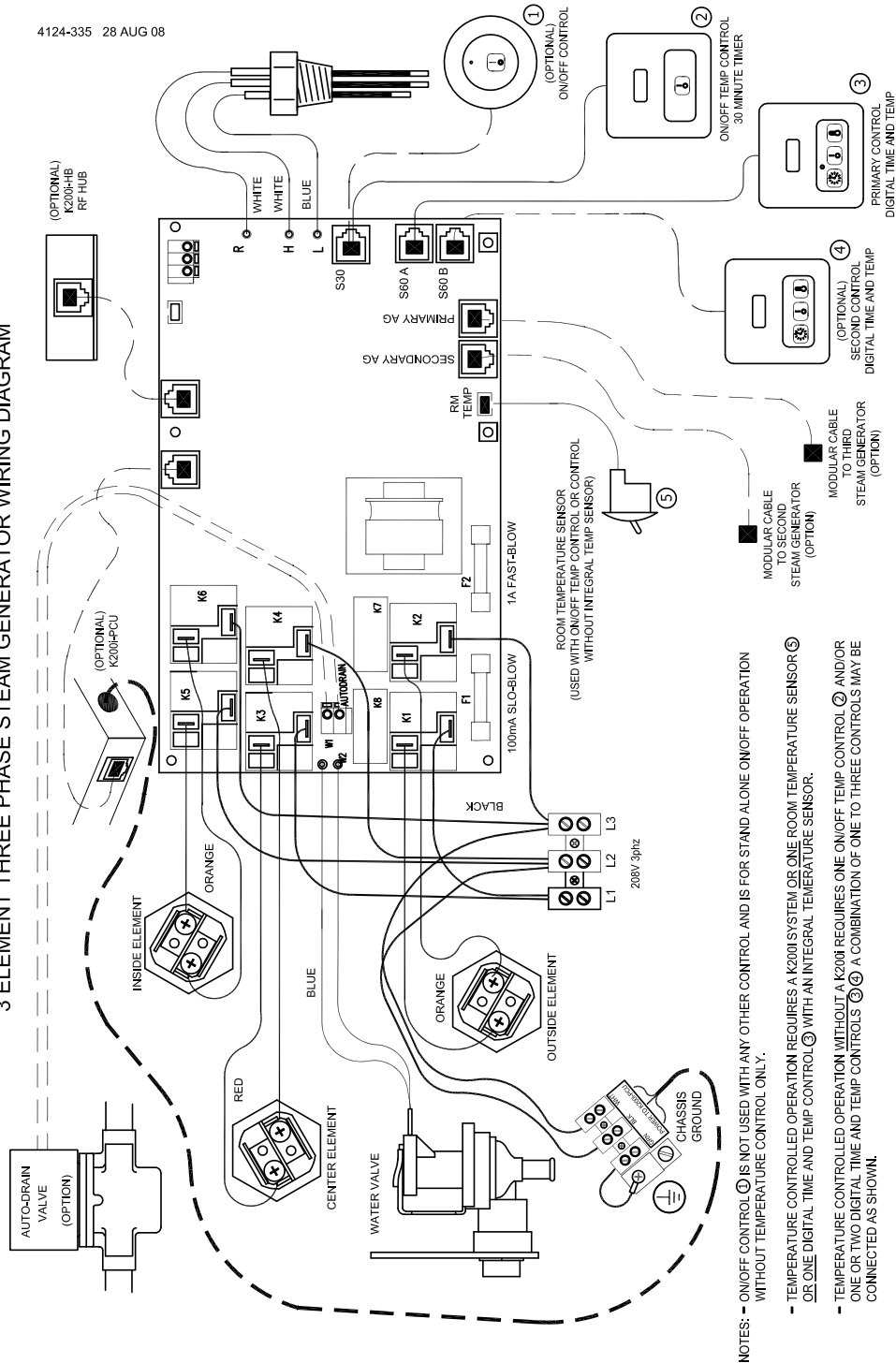

- NOTES: - ON/OFF CONTROL ① IS NOT USED WITH ANY OTHER CONTROL AND IS FOR STAND ALONE ON/OFF OPERATION WITHOUT TEMPERATURE CONTROL ONLY.
- TEMPERATURE CONTROLLED OPERATION REQUIRES A K200H SYSTEM OR ONE ROOM TEMPERATURE SENSOR ⑤ OR ONE DIGITAL TIME AND TEMP CONTROL ② WITH AN INTEGRAL TEMPERATURE SENSOR.
- TEMPERATURE CONTROLLED OPERATION WITHOUT A K200H REQUIRES ONE ON/OFF TEMP CONTROL ② AND/OR ONE OR TWO DIGITAL TIME AND TEMP CONTROLS ③, ④. A COMBINATION OF ONE TO THREE CONTROLS MAY BE CONNECTED AS SHOWN.