

MODEL 2510 & 2510 ECONOMINDER

Service Manual

CLICK in THIS PAGE to RETURN TO Water Softener Information at InspectApedia.com

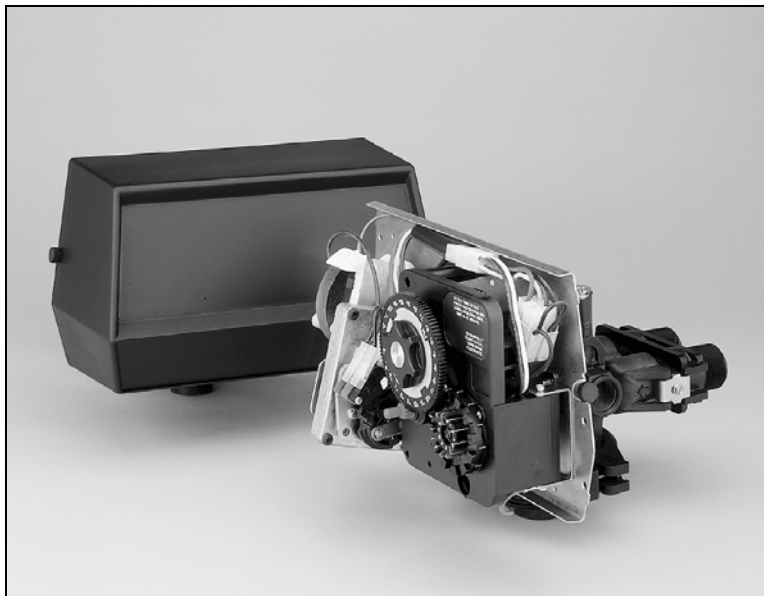

IMPORTANT: Fill in pertinent information on page 3 for future reference.

MODEL 2510 & 2510 ECONOMINDER

job specification sheet

-
- JOB NO. _____
 - *MODEL NO. _____
 - WATER TEST _____
 - CAPACITY PER UNIT _____ MAX. _____ PER REGENERATION
 - MINERAL TANK SIZE DIA. _____ HEIGHT _____
 - BRINE TANK SIZE & SALT SETTING PER REGENERATION:

• * 2510 CONTROL VALVE SPECIFICATIONS:

1. Timer Program Used
 - A. Separate Time Fill Cams
 - B. Rapid Rinse Cams
2. Type of Meter (3/4")
 - A. *Std. range 125 to 2,100 gal. setting
 - B. *Ext. range 625 to 10,500 gal. setting
3. Meter Gallon Setting _____ gal.
4. Regeneration Program Setting (see page 6)
 - A. Backwash _____ min.
 - B. Brine & Slow Rinse _____ min.
 - C. Rapid Rinse _____ min.
 - D. Brine Tank Refill _____ min.
5. Drain Line Flow Control _____ gpm
6. Brine Refill Rate _____ gpm
7. Injector Size _____

MODEL 2510 & 2510 ECONOMINDER

installation instructions

WATER PRESSURE: A minimum of 20 pounds of water pressure is required for regeneration valve to operate effectively.

ELECTRICAL FACILITIES: An uninterrupted alternating current (A/C) supply is required. Note: Other voltages are available. Please make sure your voltage supply is compatible with your unit before installation.

EXISTING PLUMBING: Condition of existing plumbing should be free from lime and iron buildup. Piping that is built up heavily with lime and/or iron should be replaced. If piping is clogged with iron, a separate iron filter unit should be installed ahead of the water softener.

LOCATION OF SOFTENER AND DRAIN: The softener should be located close to a drain to prevent air breaks and back flow.

BY-PASS VALVES: Always provide for the installation of a by-pass valve if unit is not equipped with one.

CAUTION: Water pressure is not to exceed 125 p.s.i., water temperature is not to exceed 110°F, and the unit cannot be subjected to freezing conditions.

INSTALLATION INSTRUCTIONS

1. Place the softener tank where you want to install the unit making sure the unit is level and on a firm base.
2. All plumbing should be done in accordance with local plumbing codes. The pipe size for the drain line should be a minimum of 1/2". Backwash flow rates in excess of 7 gpm or length in excess of 20' require 3/4" drain line.
3. The 1" distributor tube (1.050 O.D.) should be cut flush with top of each tank.
4. Lubricate the distributor o-ring seal and tank "o" ring seal. Place the main control valve on tank. Note: Only use silicone lubricant.
5. Solder joints near the drain must be done prior to connecting the Drain Line Flow Control fitting (DLFC). Leave at least 6" between the DLFC and solder joints when soldering pipes that are connected on the DLFC. Failure to do this could cause interior damage to the DLFC.
6. Teflon tape is the only sealant to be used on the drain fitting.
7. Make sure that the floor is clean beneath the salt storage tank and that it is level.
8. Place approximately 1" of water above the grid plate. If a grid is not utilized, fill to the top of the air check in the salt tank. Do not add salt to the brine tank at this time.
9. On units with a by-pass, place in by-pass position. Turn on the main water supply. Open a cold soft water tap nearby and let run a few minutes or until the system is free from foreign material (usually solder) that may have resulted from the installation. Once clean, close the water tap.
10. Slowly place the by-pass in service position and let water flow into the mineral tank. When water flow stops, slowly open a cold water tap nearby and let run until the air is purged from the unit.
11. Plug unit into an electrical outlet. Note: All electrical connections must be connected according to local codes. (Be certain the outlet is uninterrupted).

MODEL 2510 & 2510 ECONOMINDER

start-up instructions

The water softener should be installed with the inlet, outlet and drain connections made in accordance with the manufacturer's recommendations and to meet applicable plumbing codes.

1. Remove control box cover.
2. Make "Time of Day" setting and set "Program Wheel". (See time control instructions). Rotate program wheel counter clockwise until it stops at regeneration position.
3. Observe regeneration cycle settings. Arrange cycle times as determined in "Item 4" on "Page 2".
4. Add three inches of water to brine tank.
5. **Note:** To set the control to the various positions noted below. Turn the manual regeneration knob slowly in a clockwise direction until the Program Micro Switch lifts on top of the first set of pins. Allow the drive motor to move the piston to the first regeneration step and stop. Each time the Program Switch position changes, the valve will advance to the next regeneration step. Always allow the motor to stop before moving to the next set of pins or spaces. (See "Timer Program" instructions).

Control Valve Positions:

- | | |
|-----------------------|--|
| a. Service | Drive shaft out |
| b. Backwash | Drive shaft in |
| c. Brine / Slow Rinse | Drive shaft 1/2 way out |
| d. Rapid Rinse | Drive shaft 3/4 way out |
| e. Brine Tank Fill | Drive shaft out but brine cam holds brine valve stem in. |
6. Position valve to backwash and check to make sure that drain line flow remains steady for ten (10) minutes or until clear (see above).
 7. Position valve to brine / slow rinse position and check to see that the unit is drawing water from brine tank (this step may need repeating).
 8. Position valve to rapid rinse and check the drain line flow, run for 5 min. or until the water is clear. (Note: Rapid rinse and backwash flow rates should be the same).
 9. Position valve to start of brine tank fill cycle. See that water goes into the brine tank at proper rate. Brine valve drive cam will hold valve in at this position to fill the brine tank for the first regeneration.
 10. Replace control box cover.
 11. Put salt in brine tank (do not use granulated or rock salt).

MODEL 3200 TIMER

timer setting procedure

How To Set Days On Which Water Conditioner Is To Regenerate:

Rotate the skipper wheel until the number "1" is at the red pointer. Set the days that regeneration is to occur by sliding tabs on the skipper wheel outward to expose trip fingers. Each tab is one day. Finger at red pointer is tonight. Moving clockwise from the red pointer, extend or retract fingers to obtain the desired regeneration schedule.

How To Set The Time Of Day:

Press and hold the red button in to disengage the drive gear.

Turn the large gear until the actual time of day is at the time of day pointer.

Release the red button to again engage the drive gear.

How To Manually Regenerate Your Water Conditioner At Any Time:

Turn the manual regeneration knob clockwise.

This slight movement of the manual regeneration knob engages the program wheel and starts the regeneration program.

The black center knob will make one revolution in the following approximately three hours and stop in the position shown in the drawing.

Even though it takes three hours for this center knob to complete one revolution, the regeneration cycle of your unit might be set only one half of this time.

In any event, conditioned water may be drawn after rinse water stops flowing from the water conditioner drain line.

How to Adjust Regeneration Time:

1. Disconnect the power source.
2. Locate the three screws behind the manual regeneration knob by pushing the red button in and rotating the 24 hour dial until each screw appears in the cut out portion of the manual regeneration knob.
3. Loosen each screw slightly to release the pressure on the time plate from the 24 hour gear.
4. Locate the regeneration time pointer on the inside of the 24 hour dial in the cut out.
5. Turn the time plate so the desired regeneration time aligns next to the raised arrow.
6. Push the red button in and rotate the 24 hour dial. Tighten each of the three screws.
7. Push the red button and locate the pointer one more time to ensure the desired regeneration time is correct.
8. Reset the time of day and restore power to the unit.

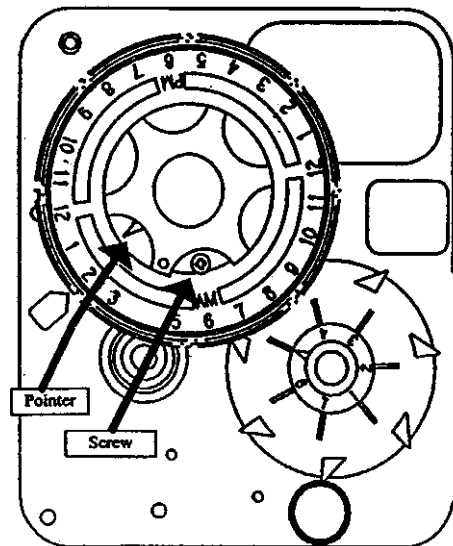
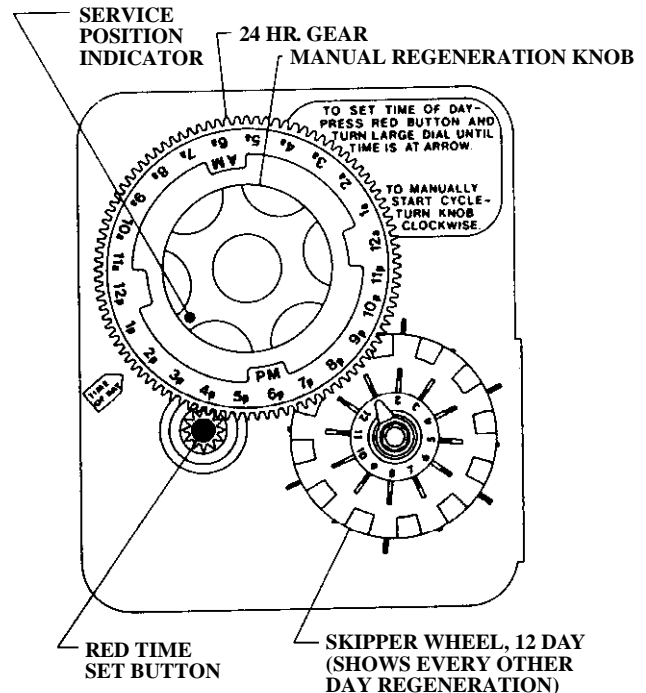

3200 ADJUSTABLE REGENERATION TIMER

IMPORTANT!

SALT LEVEL MUST ALWAYS BE ABOVE WATER LEVEL IN BRINE TANK.

MODEL 3200 TIMER

regeneration cycle program setting procedure

(brine tank refill separate from rapid rinse - stf) Black drive cam and brine valve cam

How To Set Regeneration Cycle Program:

The regeneration cycle program on your water conditioner has been factory preset, however, portions of the cycle or program may be lengthened or shortened in time to suit local conditions.

To expose cycle program wheel, grasp timer in upper left-hand corner and pull, releasing snap retainer and swinging timer to the right.

To change the regeneration cycle program, the program wheel must be removed. Grasp program wheel and squeeze protruding lugs towards center, lift program wheel off timer. (Switch arms may require movement to facilitate removal.)

How To Change The Length Of The Backwash Time:

The program wheel as shown in the drawing is in the service position. As you look at the numbered side of the program wheel, the group of pins starting a zero determines the length of time your unit will backwash.

FOR EXAMPLE: If there are six pins in this section, the time of backwash will be 12 min. (2 min. per pin). to change the length of backwash time, add or remove pins as required. The number of pins times two equals the backwash time in minutes. (Note: Do not add pins before "0" minutes designation.)

How To Change The Length of Brine and Rinse Time:

The group of holes between the last pin in the backwash section and the second group of pins determines the length of time that your unit will brine and rinse. (2 min. per hole.)

To change the length of brine and rinse time, move the rapid rinse group of pins to give more or fewer holes in the brine and rinse section. Number of holes times two equals brine and rinse time in minutes.

How To Change The Length Of Rapid Rinse:

The second group of pins on the program wheel determines the length of time that your water conditioner will rapid rinse. (2 min. per pin.)

To change the length of rapid rinse time, add or remove pins at the higher numbered end of this section as required. The number of pins times two equals the rapid rinse time in minutes.

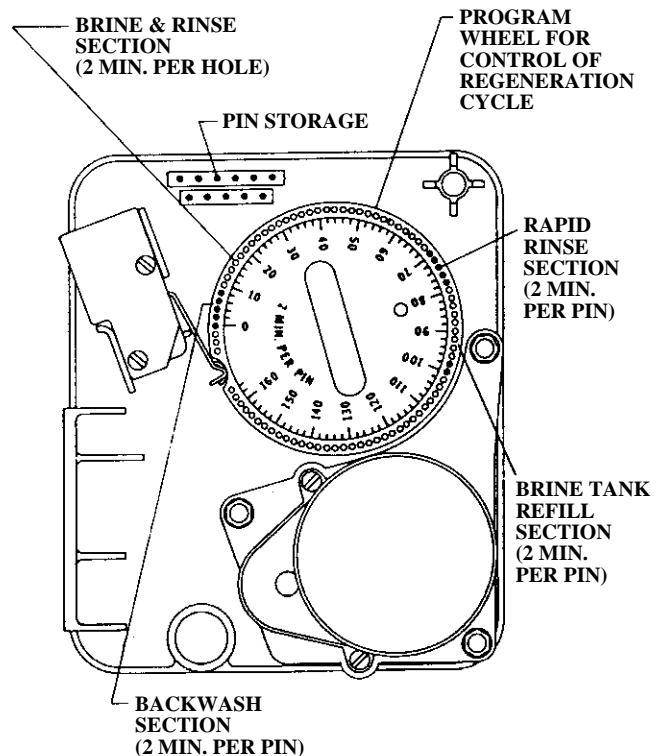

How To Change The Length Of Brine Tank Refill Time:

The second group of holes on the program wheel determines the length of time that your water conditioner will refill the brine tank. (2 min. per hole.)

To change the length of refill time, move the two pins at the end of second group of holes as required.

The regeneration cycle is complete when the outer micro-switch is tripped by the two pin set at end of the brine tank refill section. The program wheel, however, will continue to rotate until the inner micro-switch drops into the notch on the program wheel.

Return timer to closed position engaging snap retainer in back plate. make certain all electrical wires locate above snap retainer post.

IMPORTANT!

SALT LEVEL MUST ALWAYS BE ABOVE WATER LEVEL IN BRINE TANK.

MODEL 3200 TIMER

regeneration cycle program setting procedure

(rapid rinse) White drive cam and brine valve cam

How To Set The Regeneration Cycle Program:

The regeneration cycle program on your water conditioner has been factory preset, however, portions of the cycle or program may be lengthened or shortened in time to suit local conditions.

To expose the cycle program wheel, grasp the timer in the upper left-hand corner and pull, releasing the snap retainer and swinging the timer to the right.

To change the regeneration cycle program, the program wheel must be removed. Grasp the program wheel and squeeze the protruding lugs towards the center, lift the program wheel off the timer. (Switch arms may require movement to facilitate removal.)

How To Change The Length Of The Backwash Time:

The program wheel as shown in the drawing is in the service position. As you look at the numbered side of the program wheel, the group of pins starting at zero determines the length of time your unit will backwash.

FOR EXAMPLE: If there are six pins in this section, the time of backwash will be 12 min. (2 min. per pin). To change the length of backwash time, add or remove pins as required. The number of pins times two equals the backwash time in minutes. (**Note: Do not add pins before "0" minutes designation**)

How To Change The Length of Brine and Rinse Time:

The group of holes between the last pin in the backwash section and the second group of pins determines the length of time that your unit will brine and rinse. (2 min. per hole.)

To change the length of brine and rinse time, move the rapid rinse group of pins to give more or fewer holes in the brine and rinse section. Number of holes times two equals brine and rinse time in minutes.

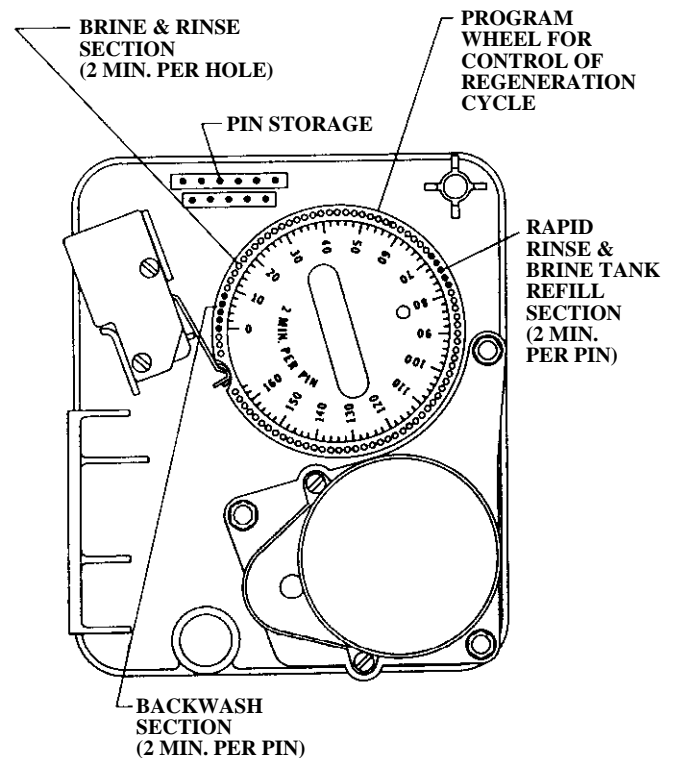

How To Change The Length Of Rapid Rinse And Brine Tank Fill Time:

The second group of pins on the program wheel determines the length of time that your water conditioner will rapid rinse and brine tank fill. (2 min. per hole.)

To change the length of rapid rinse and brine tank fill time, add or remove pins at the higher numbered end of this section as required. The number of pins times two equals the rapid rinse and brine tank fill time in minutes.

The regeneration cycle is complete when the outer micro-switch drops off the last pin in the rapid rinse and brine tank fill group of pins. The program wheel, however, will continue to rotate until the inner micro-switch drops into the notch on the program wheel.

Return the timer to the closed position, engaging the snap retainer in the back plate. Make certain all electrical wires located above the snap retainer post.

IMPORTANT!

SALT LEVEL MUST ALWAYS BE ABOVE WATER LEVEL IN BRINE TANK.

Notes

MODEL 3200 TIMER

timer assembly

(see opposite page for parts list)

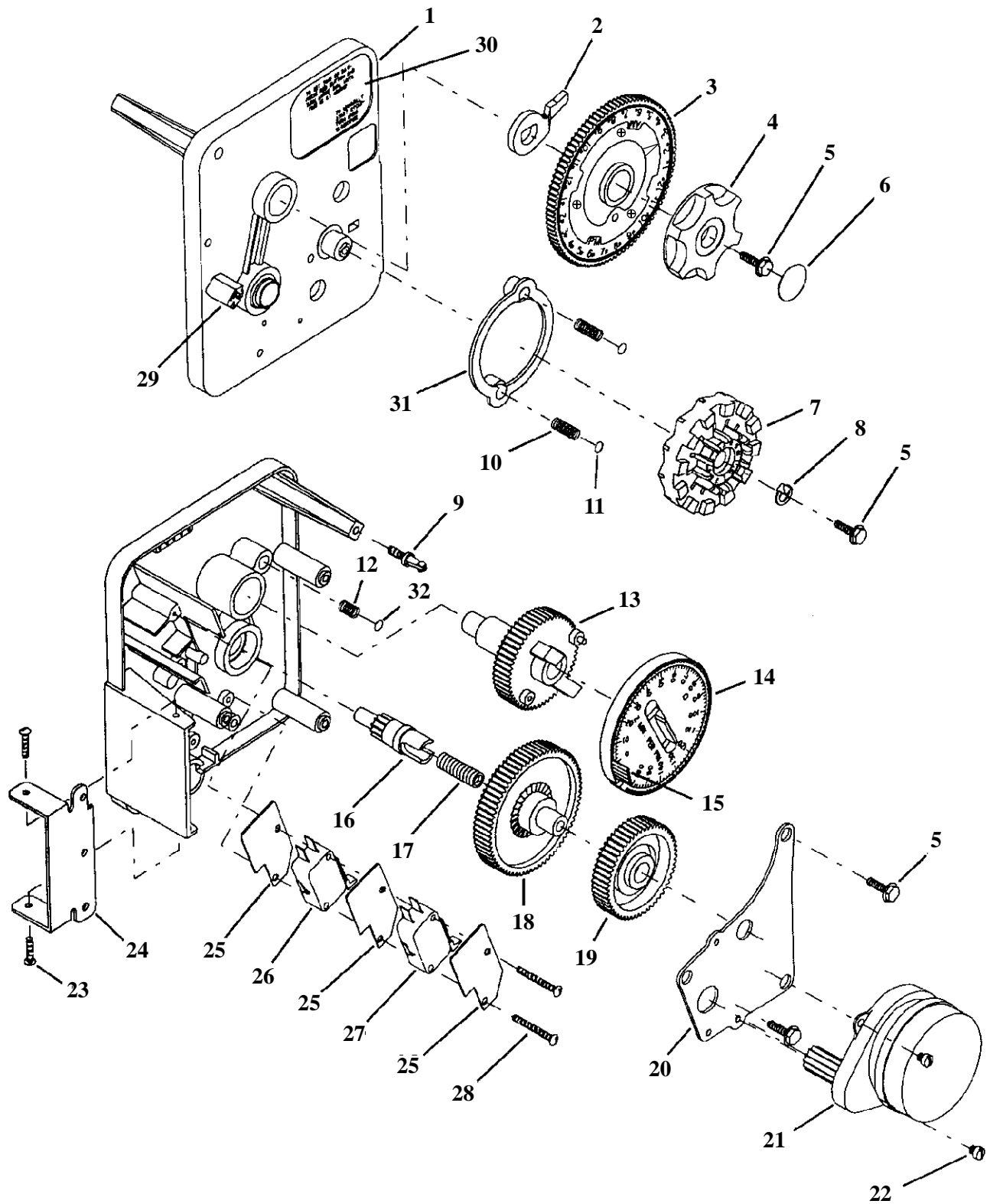

MODEL 3200 TIMER

timer assembly

(parts list)

Item No.	No. Req'd	Part No.	Description
1.....	1.....	13870.....	Timer Housing
2.....	1.....	13011.....	Cycle Actuator Arm
3.....	1.....	40096-24.....	24 Hour Gear Assembly, 12 Midnight
		40096-02.....	24 Hour Gear Assembly, 2 a.m.
4.....	1.....	13886-01.....	Knob
5.....	5.....	13296.....	Screw - Timer Knob and Motor Mtg. Plate
6.....	1.....	11999.....	Button Decal
7.....	1.....	14381.....	Skipper Wheel Assembly - 12 Day
		14860.....	Skipper Wheel Assembly - 7 Day
8.....	1.....	13014.....	Regeneration Pointer
9.....	1.....	14265.....	Spring Clip
10.....	2.....	13311.....	Spring - Skipper Wheel Detent
11.....	2.....	13300.....	Ball - 1/4 in. Dia. Skipper Wheel
12.....	1.....	15424.....	Spring - Main Gear Detent
13.....	1.....	13911.....	Main Drive Gear
14.....	1.....	19210.....	Program Wheel
15.....	21.....	15493.....	Roll Pin
16.....	1.....	13018.....	Idler Shaft
17.....	1.....	13312.....	Spring - Idler
18.....	1.....	13017.....	Idler Gear
19.....	1.....	13164.....	Drive Gear
20.....	1.....	13887.....	Motor Mounting Plate
21.....	1.....	18743.....	Motor - 120V., 60 Hz.
		19659.....	Motor - 24V., 60 Hz.
22.....	2.....	13278.....	Screw - Motor Mounting
23.....	3.....	11384.....	Screw - Timer Hinge & Ground Wire
24.....	1.....	13881.....	Hinge Bracket
25.....	3.....	14087.....	Insulator
26.....	1.....	10896.....	Switch
27.....	1.....	15320.....	Switch
28.....	2.....	11413.....	Screw - Switch Mounting
29.....	1.....	14007.....	Decal - Time of Day
30.....	1.....	14045.....	Decal - Instructions
31.....	1.....	13864.....	Skipper Wheel Ring
32.....	1.....	15066.....	Ball 1/4 in. Dia. Main Gear
Not Shown.....	1.....	13902.....	Harness
Not Shown.....	2.....	12681.....	Wire Connector
Not Shown.....	1.....	15354-01.....	Ground Wire

MODEL 2510

control valve drive assembly

(see opposite page for parts list)

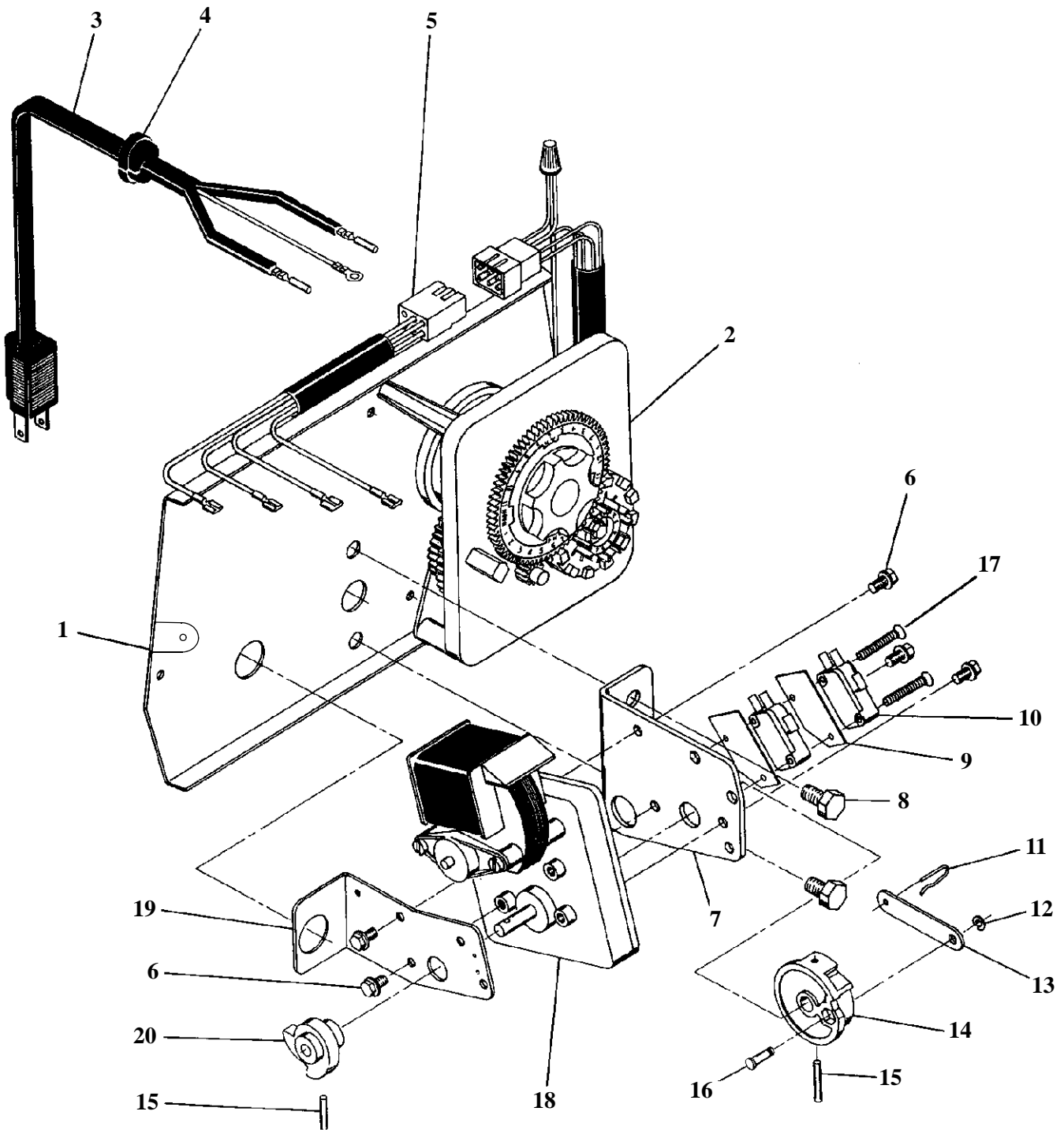

MODEL 2510

control valve drive assembly

(parts list)

Item No.	No. Req'd	Part No.	Description
1.....	1.....	14884.....	Back Plate - Stainless Steel
2.....	1.....	3200, Timer 7 or 12 Day
3.....	1.....	11838.....	Power Cord
4.....	1.....	13547.....	Strain Relief
5.....	1.....	11667.....	Wire Harness
6.....	5.....	10872.....	Screw - Motor Mounting
7.....	1.....	10774.....	Bracket - Motor Mounting
8.....	2.....	10231.....	Screw - Drive Mounting
9.....	2.....	10302.....	Insulator
10.....	2.....	10218.....	Switch
11.....	1.....	10909.....	Connecting Link Pin
12.....	1.....	10250.....	Retaining Ring
13.....	1.....	10621.....	Connecting Link
14.....	1.....	12576.....	Drive Cam - STF (Black)
	1.....	12102.....	Drive Cam - RR (White)
15.....	2.....	10338.....	Roll Pin
16.....	1.....	13366.....	Drive Bearing
17.....	2.....	14923.....	Screw - Switch Mounting
18.....	1.....	10769.....	Motor
19.....	1.....	11826.....	Bracket - Brine Valve Side
20.....	1.....	12777.....	Brine Valve Cam - STF (Black)
	1.....	10815.....	Brine Valve Cam - RR (White)
Not Shown.....	2.....	10300.....	Screw - Timer Mounting
Not Shown.....	1.....	13741.....	Hole Plug
Not Shown.....	1.....	17904.....	Hole Plug
Not Shown.....	2.....	19367.....	Screw, Thumb

MODEL 2510

control valve assembly

(see opposite page for parts list)

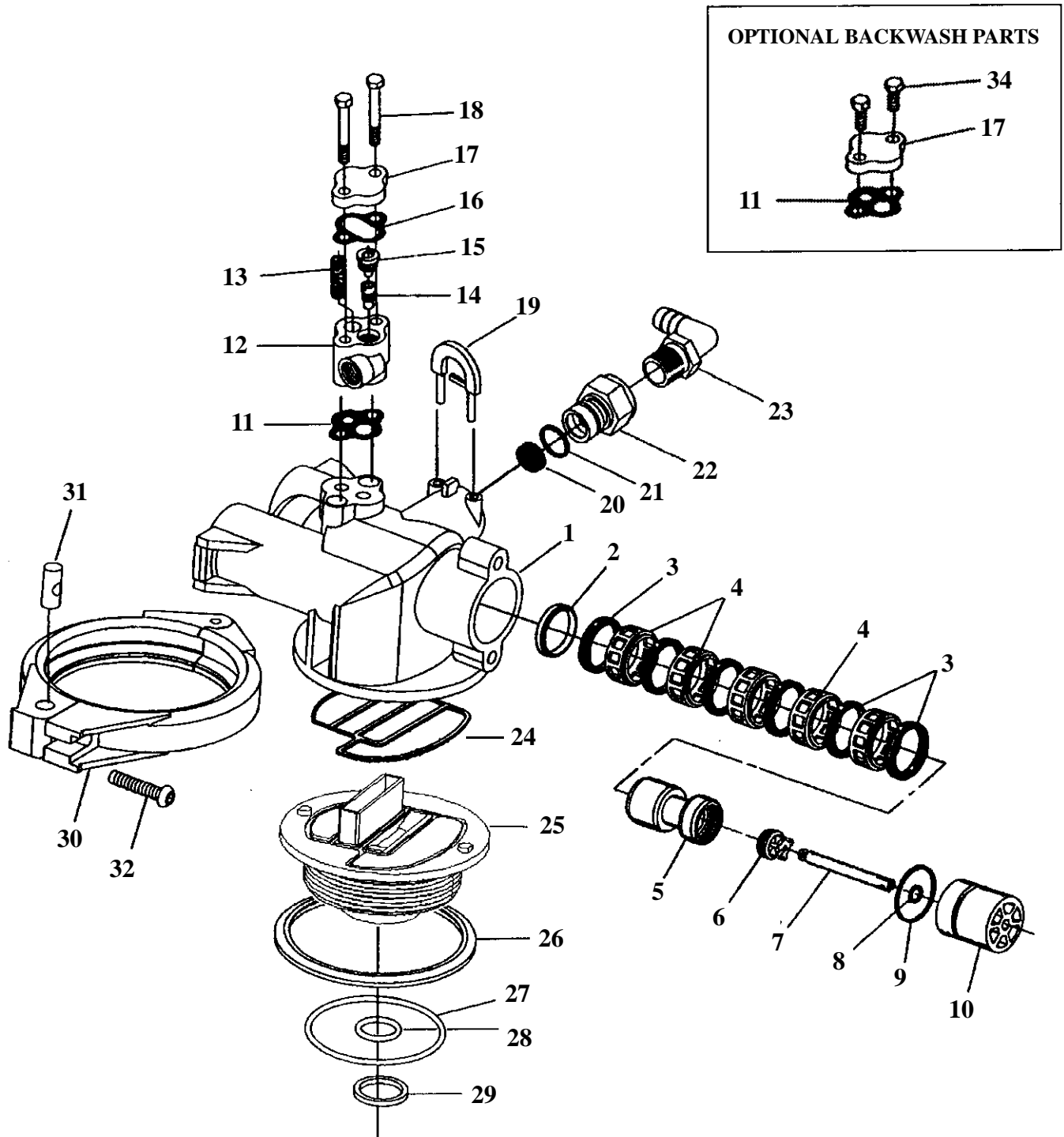

MODEL 2510

control valve assembly

(parts list)

Item No.	No. Req'd	Part No.	Description
1.....	1.....	19328.....	Valve Body
2.....	1.....	10757.....	End Spacer
3.....	6.....	10545.....	Seal Ring
4.....	5.....	11451.....	Spacer
5.....	1.....	15168.....	Piston
6.....	1.....	14309.....	Piston Rod Retainer
7.....	1.....	14452.....	Piston Rod
8.....	1.....	10209.....	Seal Quad Ring
9.....	1.....	40078.....	Seal "O" Ring - End Plug
10.....	1.....	10598.....	End Plug Assembly
11.....	1.....	14805.....	Gasket, Injector Body, 1600/1700
12.....	1.....	17776.....	Injector Body - Plastic
13.....	1.....	10227.....	Injector Screen
14.....	1.....	10914.....	Injector Throat (Specify Size)
15.....	1.....	10913.....	Injector Nozzle (Specify Size)
16.....	1.....	10229.....	Injector Cover Gasket
17.....	1.....	11893.....	Injector Cap (Plastic Body)
18.....	2.....	10692.....	Injector Body Screw
19.....	1.....	18312.....	Drain Retainer
20.....	1.....		Flow Control Washer (Specify Flow Rate in GPM)
21.....	1.....	11183.....	Seal "O" Ring
22.....	1.....	11385.....	Flow Control Housing
23.....	1.....	12338.....	1/2 Pipe x 1/2 Hose x 90° Drain Fitting
24.....	1.....	19936.....	Base Seal
25.....	1.....	19322.....	Adapter Base (2 1/2-8 Thd)
26.....	1.....	19197.....	Slip Ring
27.....	1.....	18303.....	Tank O-Ring
28.....	1.....	13304.....	Distributor O-Ring
29.....	1.....	13030.....	Retainer, Distributor Tube O-Ring
30.....	1.....	60503.....	Clamp Assembly
31.....	1.....	19998.....	Clamp Pivot
32.....	1.....	40057.....	Clamp Screw
	1.....	40000.....	Pin Hinge (not shown)
NOTE: FOR BACKWASH FILTER VALVE - REPLACE ITEMS 12-18			
17.....	1.....	11893.....	Injector Cap
34.....	2.....	15137.....	Screw Flat Cap
11.....	1.....	11475.....	Injector Body Gasket

MODEL 2510 ECONOMINDER

demand regeneration control

Typical Residential Application

To program, just set the time, set the hardness and it automatically monitors system needs and regenerates only when necessary. To set time of day press red time set button and turn 24 hour gear until present time of day is opposite "time of day arrow." Set program wheel by lifting the "people" dial and rotating it so that the number of people in the household is aligned with the grains per gallon water hardness scale. Release the dial and check for firm engagement at setting. (This method will provide reserve capacity based on 75 gallons per person.)

Optional Programming Procedure

Calculate the gallon capacity of the system, subtract the necessary reserve requirement and set the gallons available opposite the small white dot on the program wheel gear. Note, drawing shows 850 gallon setting. The capacity (gallons) arrow denotes remaining gallons exclusive of fixed reserve.

ie: Calculated gallon capacity of system is 1000 gallons. Number of people using the system is 4. Use 75 gallons per person for a safe reserve capacity - 300 gallons reserve = 700 gallons available. This number should be set opposite the white dot on program wheel.

How To Set The Time Of Day:

Press and hold the red button in to disengage the drive gear.

Turn the large gear until the actual time of day is at the time of day pointer.

Release the red button to again engage the drive gear.

How To Manually Regenerate Your Water Conditioner At Any Time:

Turn the manual regeneration knob clockwise.

This slight movement of the manual regeneration knob engages the program wheel and starts the regeneration program.

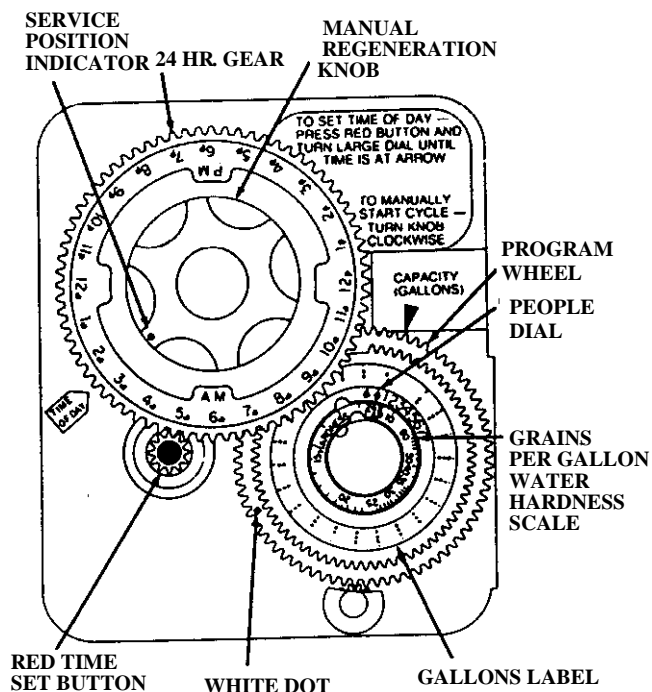

The black center knob will make one revolution in the following approximately three hours and stop in the position shown in the drawing.

Even though it takes three hours for this center knob to complete one revolution, the regeneration cycle of your unit might be set only one half of this time.

In any event, conditioned water may be drawn after rinse water stops flowing from the water conditioner drain line.

IMPORTANT!

SALT LEVEL MUST ALWAYS BE ABOVE WATER LEVEL IN BRINE TANK.

MODEL 3210

regeneration cycle program setting procedure

How to Set The Regeneration Cycle Program:

The regeneration cycle program on your water conditioner has been factory preset, however, portions of the cycle or program may be lengthened or shortened in time to suit local conditions.

If unit has a meter, disconnect meter cable from meter at this time.

To expose cycle program wheel, grasp timer in upper left-hand corner and pull, releasing snap retainer and swinging timer to the right. **(meter cable must be disconnected)**

To change the regeneration cycle program, the program wheel must be removed. Grasp program wheel and squeeze protruding lugs towards center, lift program wheel off timer. (Switch arms may require movement to facilitate removal.)

How To Change The Length Of The Backwash Time:

The program wheel as shown in the drawing is in the service position. As you look at the numbered side of the program wheel, the group of pins starting at zero determines the length of time your unit will backwash.

FOR EXAMPLE: If there are six pins in this section, the time of backwash will be 12 min. (2 min. per pin). to change the length of backwash time, add or remove pins as required. The number of pins times two equals the backwash time in minutes.

How To Change The Length of Brine and Rinse Time:

The group of holes between the last pin in the backwash section and the second group of pins determines the length of time that your unit will brine and rinse. (2 min. per hole.)

To change the length of brine and rinse time, move the rapid rinse group of pins to give more or fewer holes in the brine and rinse section. Number of holes times two equals brine and rinse time in minutes.

How To Change The Length Of Brine Tank Refill Separate From Rapid Rinse: STF Black Cams

The second group of pins on the program wheel determines the length of time that your water conditioner will rapid rinse. (2 min. per pin.)

To change the length of rapid rinse time, add or remove pins at the higher numbered end of this section as required. The number of pins times two equals the rapid rinse time in minutes.

How To Change The Length Of Brine Tank Refill Time:

The second group of holes on the program wheel determines the length of time that your water conditioner will refill the brine tank. (2 min. per hole.)

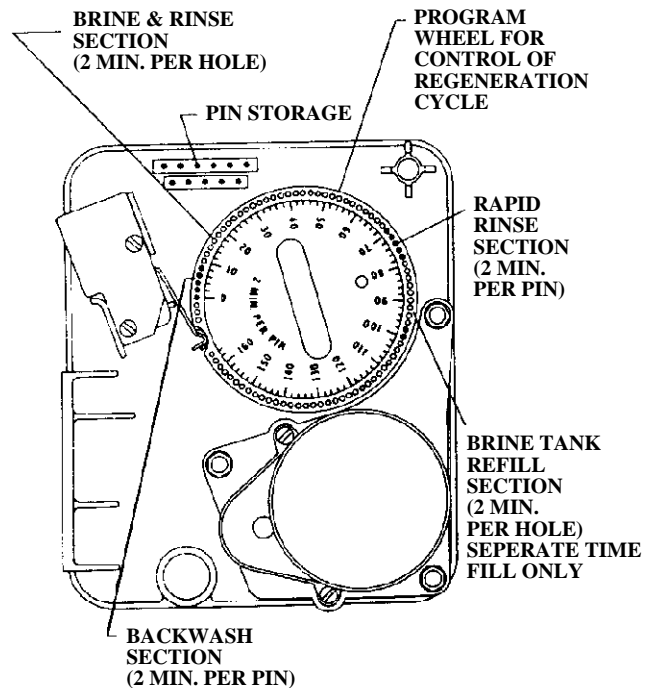

To change the length of refill time, move the two pins at the end of second group of holes as required.

The regeneration cycle is complete when the outer micro-switch is tripped by the two pinset at end of the brine tank refill section. The program wheel, however, will continue to rotate until the inner micro-switch drops into the notch on the program wheel.

How To Change The Length Of Rapid Rinse And Brine Tank Fill Time: RR White Cams

The second group of pins on the program wheel determines the length of time that your water conditioner will rapid rinse and brine tank fill. (2 min. per pin.)

To change the length of rapid rinse and brine tank fill time, add or remove pins at the higher numbered end of this sections as required. The number of pins times two equals the rapid rinse and brine tank fill time in minutes.

The regeneration cycle is complete when the outer micro-switch drops off the last pin in the rapid rinse and brine tank fill group of pins. The program wheel, however, will continue to rotate until the inner micro-switch drop into the notch on the program wheel.

Return timer to closed position engaging snap retainer in back plate. Make certain all electrical wires locate above snap retainer post and the meter cable slides though the backplate and does not bind. Reconnect meter cable.

MODEL 3210

timer assembly

(see opposite page for parts list)

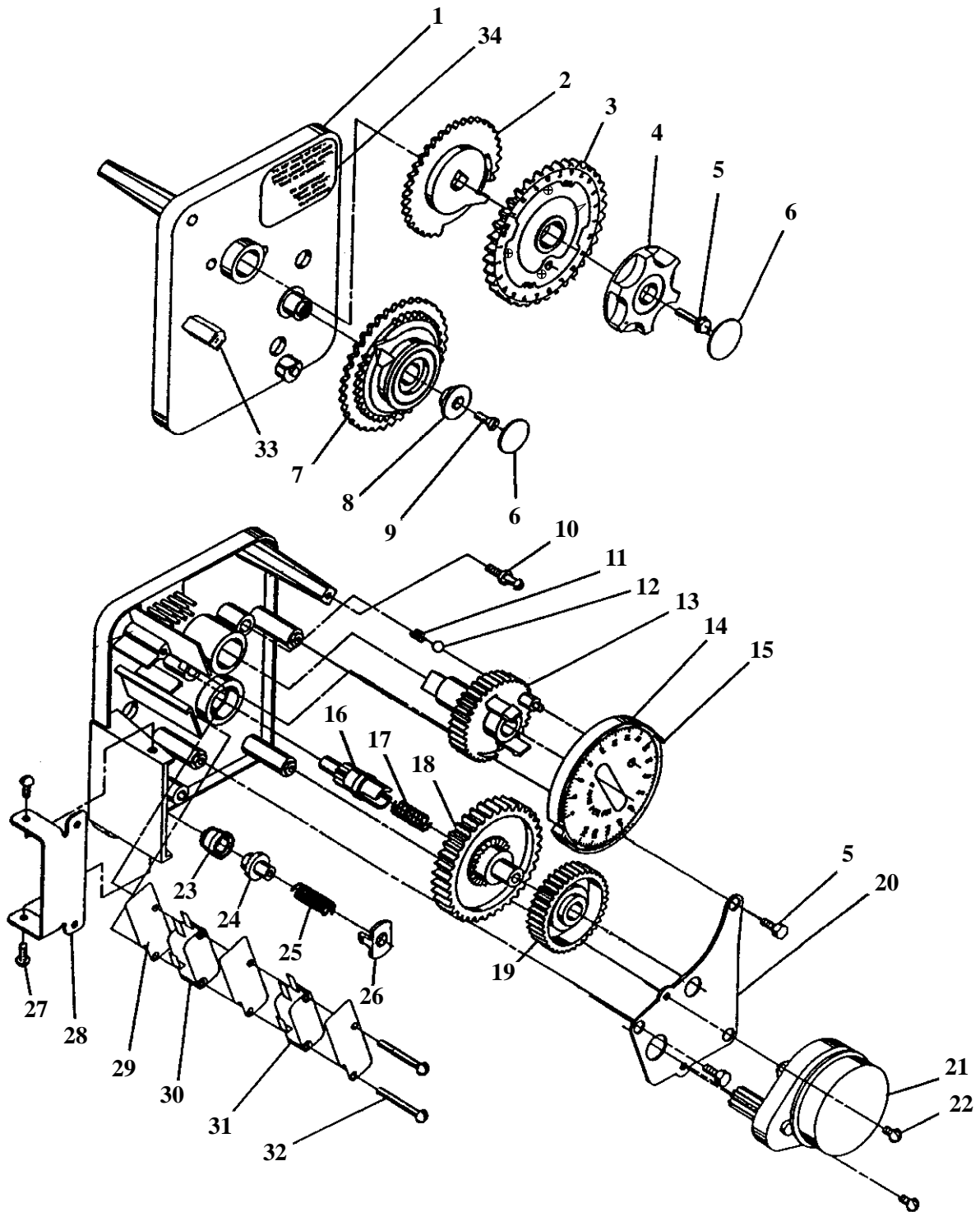

MODEL 3210

timer assembly

(parts list)

Item No.	No. Req'd	Part No.	Description
1.....	1.....	13870-01.....	Timer Housing Assembly
2.....	1.....	13802.....	Cycle Actuator Gear
3.....	1.....	40096-24.....	24 Hour Gear Assembly, 12 Midnight
		40096-02.....	24 Hour Gear Assembly, 2 a.m.
4.....	1.....	13886-01.....	Knob
5.....	4.....	13296.....	Screw - Timer Knob and Motor Plate Mtg.
6.....	2.....	11999.....	Button Decal
7.....	1.....	60405-15.....	Program Wheel Assy. (Specify Hardness Capacity)
8.....	1.....	13806.....	Program Wheel Retainer
9.....	1.....	13748.....	Screw - Program Wheel Mtg.
10.....	1.....	14265.....	Spring Clip
11.....	1.....	15424.....	Spring - Detent
12.....	1.....	15066.....	Ball - 1/4 in. Dia.
13.....	1.....	13911.....	Main Drive Gear
14.....	1.....	19210.....	Program Wheel
15.....	21.....	15493.....	Roll Pin
16.....	1.....	13018.....	Idler Shaft
17.....	1.....	13312.....	Spring - Idler
18.....	1.....	13017.....	Idler Gear
19.....	1.....	13164.....	Drive Gear
20.....	1.....	13887.....	Motor Mounting Plate
21.....	1.....	18743.....	Motor - 120V., 60 Hz.
		19659.....	Motor - 24V., 60 Hz.
22.....	2.....	13278.....	Screw, Motor Mounting
23.....	1.....	13830.....	Drive Pinion - Program Wheel
24.....	1.....	13831.....	Clutch - Drive Pinion
25.....	1.....	14276.....	Spring
26.....	1.....	14253.....	Spring Retainer
27.....	3.....	11384.....	Screw - Timer Hinge and Ground Wire
28.....	1.....	13881.....	Hinge Bracket
29.....	3.....	14087.....	Insulator
30.....	1.....	10896.....	Switch
31.....	1.....	15320.....	Switch
32.....	2.....	11413.....	Screw - Switch Mounting
33.....	1.....	14007.....	Decal - Time of Day
34.....	1.....	14045.....	Decal - Instructions
Not Shown.....	1.....	13902.....	Harness
Not Shown.....	2.....	12681.....	Wire Connector
Not Shown.....	1.....	15354-01.....	Ground Wire 17748-01 F.E

MODEL 2510 ECONOMINDER

control valve drive assembly

(see opposite page for parts list)

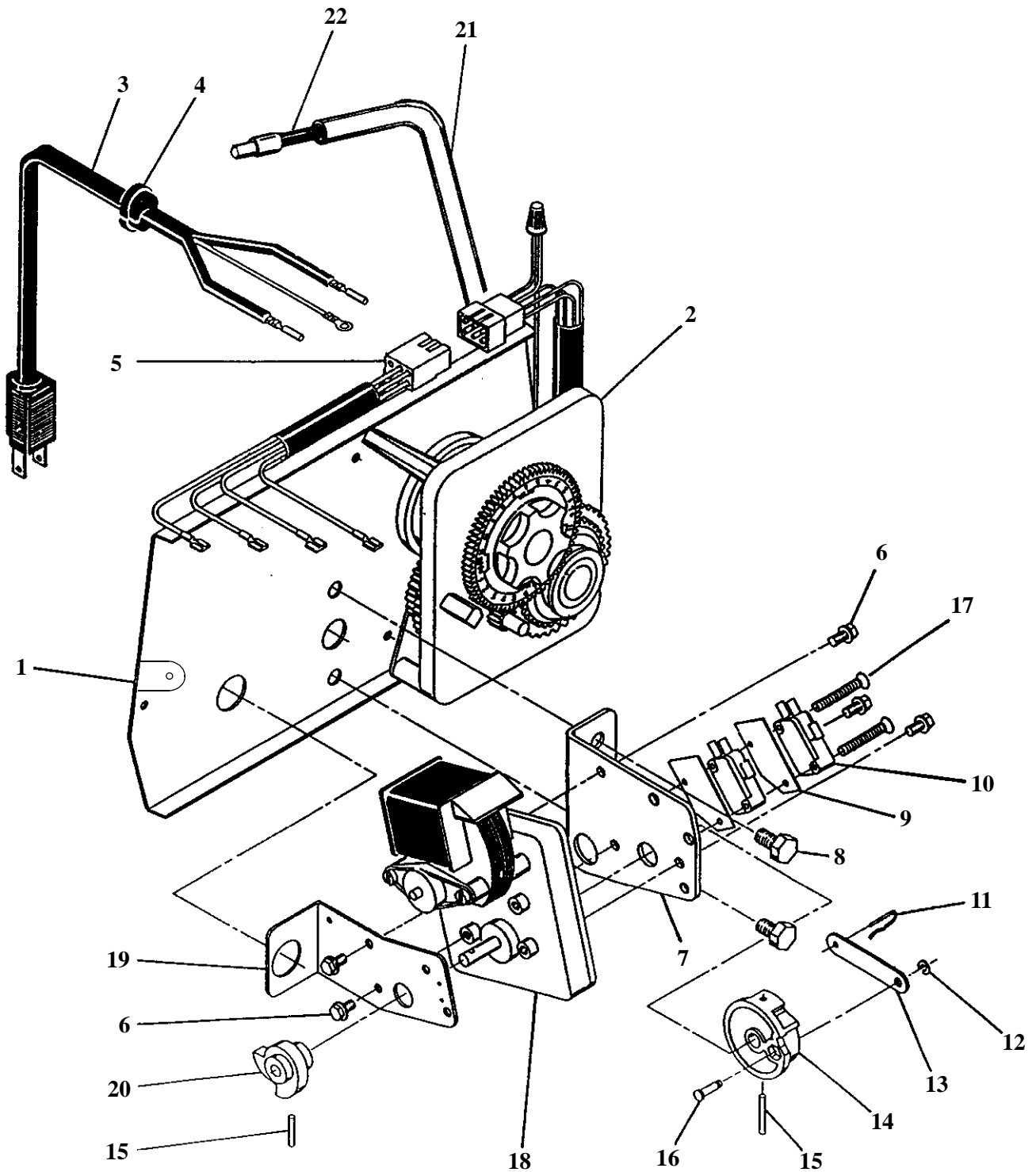

MODEL 2510 ECONOMINDER

control valve drive assembly

(parts list)

Item No.	No. Req'd	Part No.	Description
1.....	1.....	14884.....	Back Plate - Stainless Steel
2.....	1.....	60306-13.....	3210 Delay Timer, STF, 120V/60
	1.....	60306-03.....	3210 Delay Timer, STF, 120V/60
3.....	1.....	11838.....	Power Cord
4.....	1.....	13547.....	Strain Relief
5.....	1.....	11667.....	Wire Harness
6.....	5.....	10872.....	Screw - Motor Mounting
7.....	1.....	10774.....	Bracket - Motor Mounting
8.....	2.....	10231.....	Screw - Drive Mounting
9.....	2.....	10302.....	Insulator
10.....	2.....	10218.....	Switch
11.....	1.....	10909.....	Connecting Link Pin
12.....	1.....	10250.....	Retaining Ring
13.....	1.....	10621.....	Connecting Link
14.....	1.....	12576.....	Drive Cam - STF (Black)
	1.....	12102.....	Drive Cam - RR (White)
15.....	2.....	10338.....	Roll Pin
16.....	1.....	13366.....	Drive Bearing
17.....	2.....	14923.....	Screw - Switch Mounting
18.....	1.....	10769.....	Motor
19.....	1.....	11826.....	Bracket - Brine Valve Side
20.....	1.....	12777.....	Brine Valve Cam - STF (Black) - (shown)
	1.....	10815.....	Brine Valve Cam - RR (White)
21.....	1.....	15441.....	Meter Cable Guide Ass'y
22.....	1.....	15495.....	Meter Cable, 13" Std./Ext., Rt. Angle
Not Shown.....	2.....	10300.....	Screw - Timer Mounting
Not Shown.....	1.....	13741.....	Hole Plug
Not Shown.....	1.....	17904.....	Hole Plug
Not Shown.....	2.....	19367.....	Screw, Thumb

MODEL 2510 ECONOMINDER

meter assembly

(see opposite page for parts list)

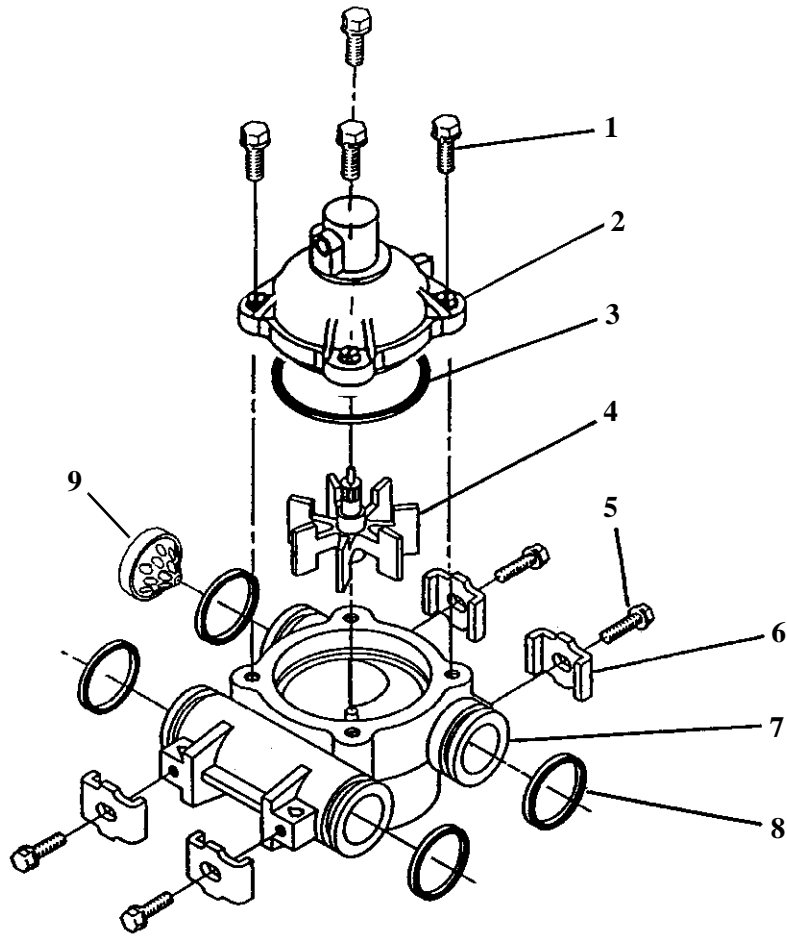

MODEL 2510 ECONOMINDER

meter assembly

(parts list)

Item No.	No. Req'd	Part No.	Description
1.....	4.....	12473.....	Screw - Meter Cover Assembly
2.....	1.....	15659.....	Meter Cover Assy. - Ext., Rt. Angle (Not Shown)
	1.....	15452.....	Meter Cap Assy, 3/4" to 2", Std, Rt Ang/90, Plas, Pdl
3.....	1.....	13847.....	"O" Ring - Meter Cover Assembly
4.....	1.....	13509.....	Impeller
5.....	4.....	13314.....	Screw - Adapter Clip
6.....	4.....	13255.....	Adapter Clip
7.....	1.....	13821.....	Meter Body
8.....	4.....	13305.....	"O" Ring - Meter Body
9.....	1.....	14613.....	Flow Straightener

MODEL 1650

plastic brine system for 2510 and 2510 econominder

(see opposite page for parts list)

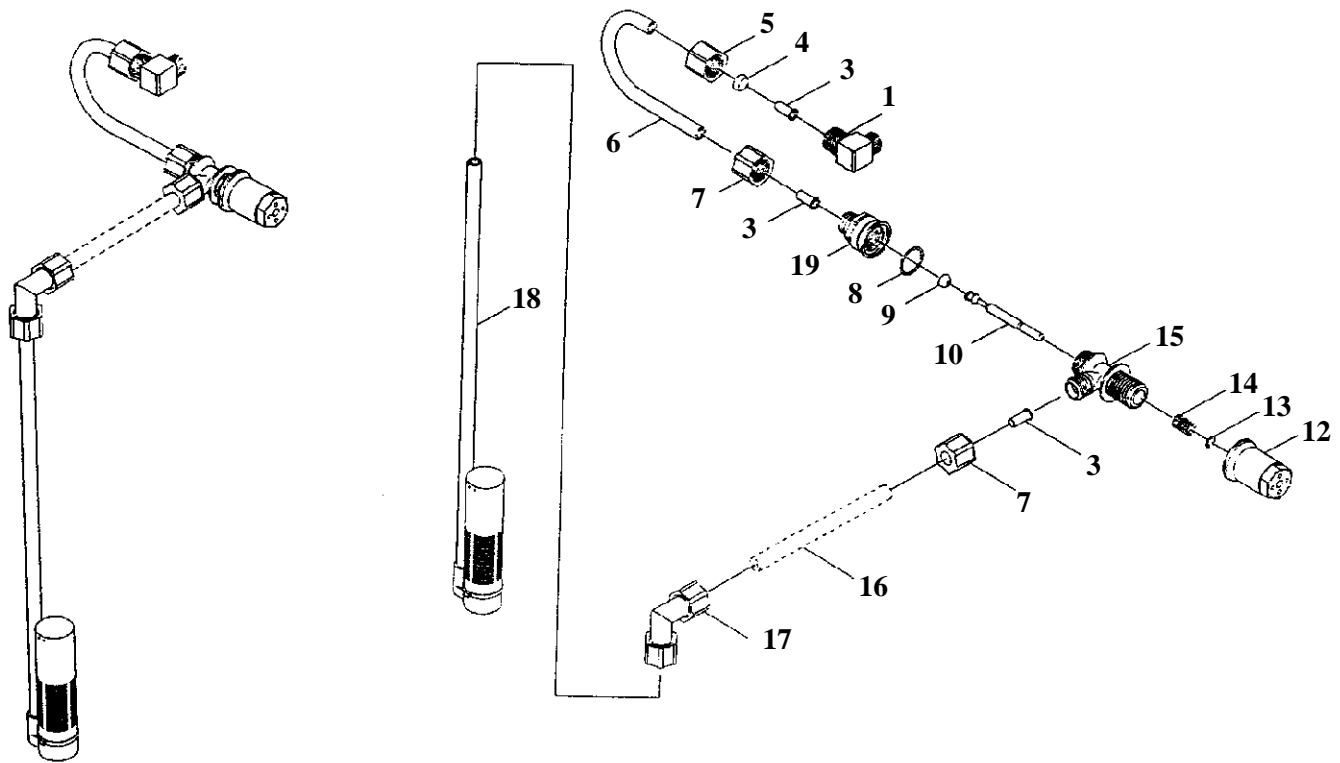

MODEL 1650

plastic brine system for 2510 and 2510 econominder

(parts list)

Item No.	No. Req'd	Part No.	Description
60011 Brine Valve Assembly, Includes Items 3-15 (Less BLFC 60010-)			
1	1	10328	Elbow, 90 1/4 NPT x 3/8
3	3	10332	Insert, 3/8
4	1	10330	Sleeve, 3/8 Nut Brine
5	1	10329	Tube Fitting, 3/8 Nut Brine
6	1	40027	Tube, Brine Valve
7	2	19625	Assy., GFN Nut
8	1	16924	O-Ring
9	1	12626	Seat, Brine Valve
10	1	12552	Brine Valve Stem, 1600
12	1	17906	Guide, Brine Valve Stem
13	1	10250	Retaining Ring
14	1	10249	Spring, Brine Valve
15	1	17884	Brine Valve Body Assy., Plastic
16	1		Not Supplied
17	1	12794	Elbow, 3/8 Tube Poly, White
18	1	60002	#500 Air Check
19	1	60010-xx	BLFC Assy.
60010-25 BLFC Assy. (Parts)			
	1	17907	Housing
	1	12128	.25 GPM Label
	1	12094	.25 Flow Washer
	1	12098	Retainer
60010-50 BLFC Assy. (Parts)			
	1	17907	Housing
	1	10759	.50 GPM Label
	1	12095	.50 Flow Washer
	1	12098	Retainer
60010-100 BLFC Assy. (Parts)			
	1	17907	Housing
	1	10760	1.0 GPM Label
	1	12097	1.0 Flow Washer
	1	12098	Retainer
		Part No.	Description
		60080-XX	Injector Assembly (For Illustration and Parts, See Page 12)
		60090	Piston Assembly (For Illustration and Parts, See Page 12)

MODEL 2510

coupling assembly with yoke

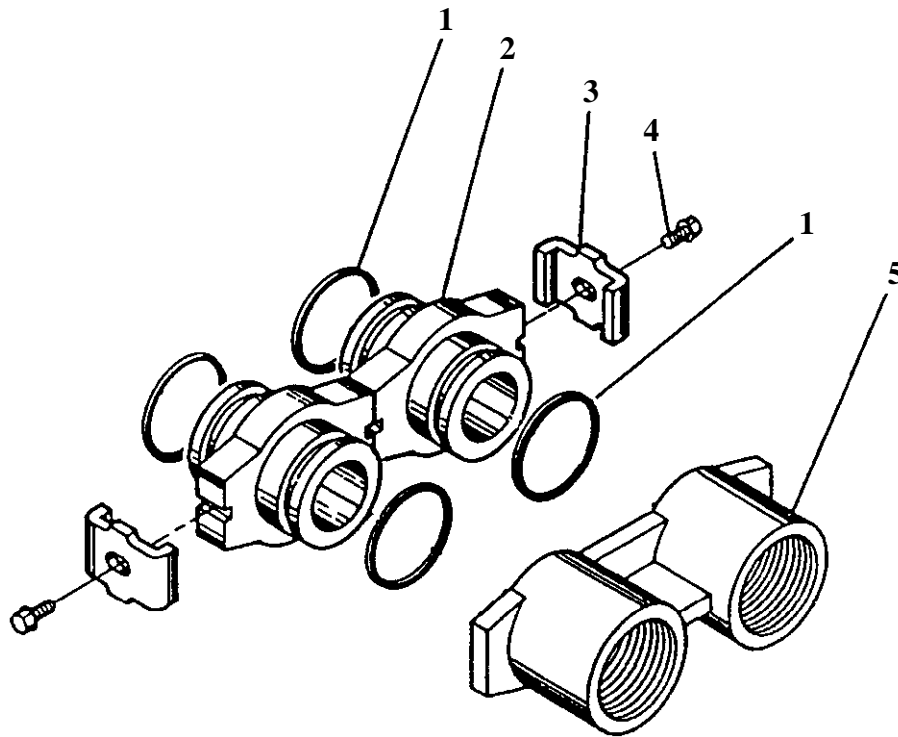

PARTS LIST

Item No.	No. Req'd	Part No.	Description
1	4	13305	O-Ring, Adapter Coupling
2	2	19228	Adapter Coupling
3	2	13255	Clip, Adapter Coupling
4	2	13314	Screw, Adapter Coupling
5	1	13708	Adapter, 3/4" Yoke NPT

MODEL 2510

service assemblies

(parts list)

60050-21.....	2510/2750 Drive Motor Assembly - STF (For Illustration and Parts, See Pages 10 & 18)
60050-11.....	2510/2750 Drive Motor Assembly - RR
60306-13.....	Timer, 3210 Delay - STF (For Illustration and Parts, See Pages 16 & 17)
60307-03.....	Timer, 3210 Delay - RR
60307-13.....	Timer, 3220 Delay - STF
60307-03.....	Timer, 3220 Delay - RR
60303-13.....	Timer, 3220 / 7 Day - STF
60304-13.....	Timer, 3220 / 12 Day - STF
60303-03.....	Timer, 3220 / 7 Day - RR
60304-04.....	Timer, 3220 / 12 Day - RR
60088-180.....	Meter, Std., Rt. Angle (For Illustration and Parts, See Pages 20 & 21)
60089-180.....	Meter, Ext. Range, Rt. Angle
60510.....	Coupling Assembly
60001.....	1650 Brine Valve (For Illustration and Parts, See Pages 22 & 23)
60503.....	Clamp Assembly (For Illustration and Parts, See Page 12)
60010-25.....	BLFC Assembly (.25 gpm) For 1650 (For Parts, See Page 23)
60010-50.....	BLFC Assembly (.50 gpm) For 1650 (For Parts, See Page 23)
60010-100.....	BLFC Assembly (1.0 gpm) For 1650 (For Parts, See Page 23)
60121.....	Seal and Spacer Kit (For Illustration and Parts, See Pages 12 & 13)
60040.....	3/4" Bypass NPT
60040NP.....	3/4" Bypass NPT Nickel
60041.....	1" Bypass NPT
60041NP.....	1" Bypass NPT Nickel
60049.....	Bypass, Plastic

MODEL 2510 & 2510 ECONOMINDER

wiring diagram for valve drive motor and timer

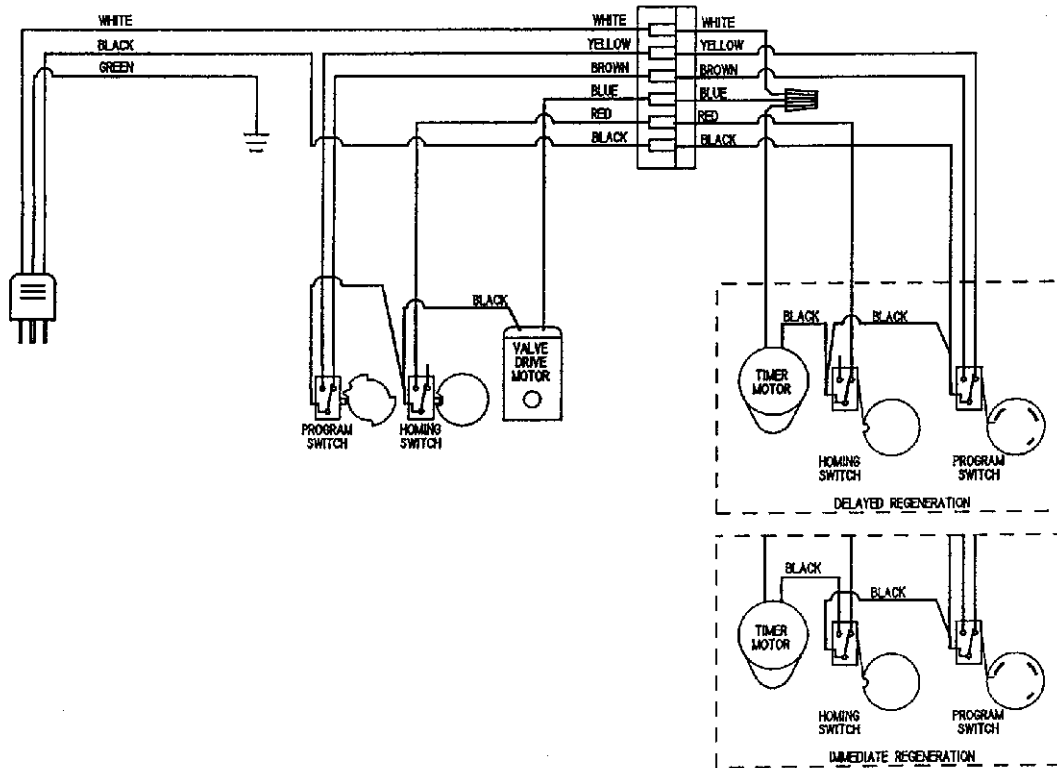

2510 downflow

Tank Dia.	Resin Load	Injector	Inj. Color	Draw / Slow Rinse Rate (GPM)*	BLFC**	DLFC***	Timer Settings****	Total Capacity
6"	.35 Cu Ft	#000	Brown	.11 gpm / .19 gpm	.25 gpm	.8 gpm	8-50-5-6	9,450 Grains
7"	.56 Cu Ft	#00	Violet	.21 gpm / .32 gpm	.25 gpm	1.2 gpm	8-50-8-8	15,120 Grains
8"	.8 Cu Ft	#00	Violet	.21 gpm / .32 gpm	.25 gpm	1.5 gpm	8-50-8-12	21,600 Grains
9"	1.0 Cu Ft	#0	Red	.26 gpm / .52 gpm	.25 gpm	2.0 gpm	10-50-10-14	27,000 Grains
10"	1.25	#1	White	.35 gpm / .7 gpm	.5 gpm	2.4 gpm	10-50-10-8	33,750 Grains
12"	2.0 Cu Ft	#2	Blue	.48 gpm / .9 gpm	.5 gpm	3.5 gpm	5-8-50-14	54,000 Grains
13"	2.5 Cu Ft	#3	Yellow	.63 gpm / 1.13 gpm	1.0 gpm	4.0 gpm	5-8-50-8	67,500 Grains
14"	3.0 Cu Ft	#3	Yellow	.63 gpm / 1.13 gpm	1.0 gpm	4.5 gpm	5-8-50-10	81,000 Grains

1 cubic foot of resin will have 27,000 grains of softening capacity when regenerated with 10 lbs. of salt.

* All listed flows at 60 PSI and will vary at different pressures.

** B.L.F.C. (Brine Line Flow Control) Refill rate for filling the brine tank.

*** D.L.F.C. (Drain Line Flow Control) All flows calculated at 4.5 GPM Per SQ FT of bed area.

The above chart to only be used as a guide. Water Conditions and resin loads may vary. Always consult OEM for details.

Notes

MODEL 2510 & 2510 ECONOMINDER

service instructions

PROBLEM	CAUSE	CORRECTION
1. Softener Fails to Regenerate	A. Electrical Service To Unit Has Been Interrupted. B. Timer is Defective C. Power Failure.	A. Assure Permanent electrical Service (Check Fuse, Plug, Pull chain or Switch). B. Replace Timer. C. Reset Time of Day.
2. Hard Water	A. By-Pass Valve is Open. B. No Salt in Brine Tank. C. Injector Screen Plugged. D. Insufficient Water Flowing Into Brine Tank. E. Hot Water Tank Hardness. F. Leak At Distributor Tube. G. Internal Valve Leak.	A. Close By-Pass Valve. B. Add Salt To Brine Tank and Maintain Salt Level Above Water Level. C. Clean Injector Screen. D. Check Brine Tank Fill Time and Clean Brine Line Flow Control if Plugged. E. Repeat Flushings of the Hot Water Tank is Required. F. Make Sure Distributor Tube is Not Cracked. Check "O" Ring and Tube Pilot. G. Replace Seals and Spacers and/or Piston.
3. Unit Used Too Much Salt.	A. Improper Salt Setting. B. Excessive Water in Brine Tank.	A. Check Salt Usage and Salt Setting. B. See Problem No. 7.
4. Loss of Water Pressure	A. Iron Buildup in Line to Water Conditioner. B. Iron Buildup in Water Conditioner. C. Inlet of Control Plugged Due to Foreign Material Broken Loose From Pipes by Recent Work Done on Plumbing System.	A. Clean Line to Water Conditioner. B. Clean Control and Add Mineral Cleaner to Mineral Bed. Increase Frequency of Regeneration. C. Remove Piston and Clean Control.
5. Loss of Mineral Through Drain Line.	A. Air in Water System.	A. Assure that Well System has Proper Air Eliminator Control. Check for Dry Well Condition.
6. Iron in Conditioned Water.	A. Fouled Mineral Bed.	A. Check Backwash, Brine Draw and Brine Tank Fill. Increase Frequency of Regeneration. Increase Backwash Time.
7. Excessive Water in Brine Tank.	A. Plugged Drain Line Flow Control. B. Plugged Injector System.	A. Clean Flow Control. B. Clean Injector and Screen.
7. Excessive Water in Brine Tank (continued)	C. Timer Not Cycling. D. Foreign Material in Brine Valve.	C. Replace timer. D. Replace Brine Valve Seat and Clean Valve.

Delayed Regeneration Timer Assembly (continued)

PROBLEM	CAUSE	CORRECTION
8. Softener Fails to Draw brine.	<ul style="list-style-type: none"> E. Foreign Material in Brine Line Flow Control. A. Drain Line Flow Control is Plugged. B. Injector is Plugged. C. Injector Screen Plugged. D. Line Pressure is too Low. E. Internal Control Leak. 	<ul style="list-style-type: none"> E. Clean Brine Line Flow Control. A. Clean Drain Line Flow Control. B. Clean Injector. C. Clean Screen. D. Increase Line Pressure to 20 P.S.I. E. Change Seals, Spacers and Piston Assembly.
9. Control Cycles Continuously.	<ul style="list-style-type: none"> A. Broken or Shorted Switch. 	<ul style="list-style-type: none"> A. Determine if Switch or Timer is Faulty and Replace it, or Replace Complete Power Head.
10. Drain Flows Continuously.	<ul style="list-style-type: none"> A. Valve is not Programing Correctly. B. Foreign Material in Control. C. Internal Control Leak. 	<ul style="list-style-type: none"> A. Check Timer Program and Positioning of Control. Replace Power Head Assembly if not Positioning Properly. B. Remove Power Head Assembly and Inspect Bore. Remove Foreign Material and Check Control in Various Regeneration Positions. C. Replace Seals and Piston Assembly.

GENERAL SERVICE HINTS FOR METER CONTROL

Problem: Softener Delivers Hard Water

Cause could be that . . . Reserve capacity has been exceeded.

Correction: Check salt dosage requirements and reset program wheel to provide additional reserve.

Cause could be that . . . Program wheel is not rotating with meter output.

Correction: Pull cable out of meter cover and rotate manually. Program wheel must move without binding and clutch must give positive “clicks” when program wheel strikes regeneration stop. If it does not, replace timer.

Cause could be that . . . Meter is not measuring flow.

Correction: Check output by observing rotation of small gear on front of timer (Note - program wheel must not be against regeneration stop for this check). Each tooth to tooth is approximately 30 gallons. If not performing properly, replace meter.

MODEL 2510 & 2510 ECONOMINDER

service instructions

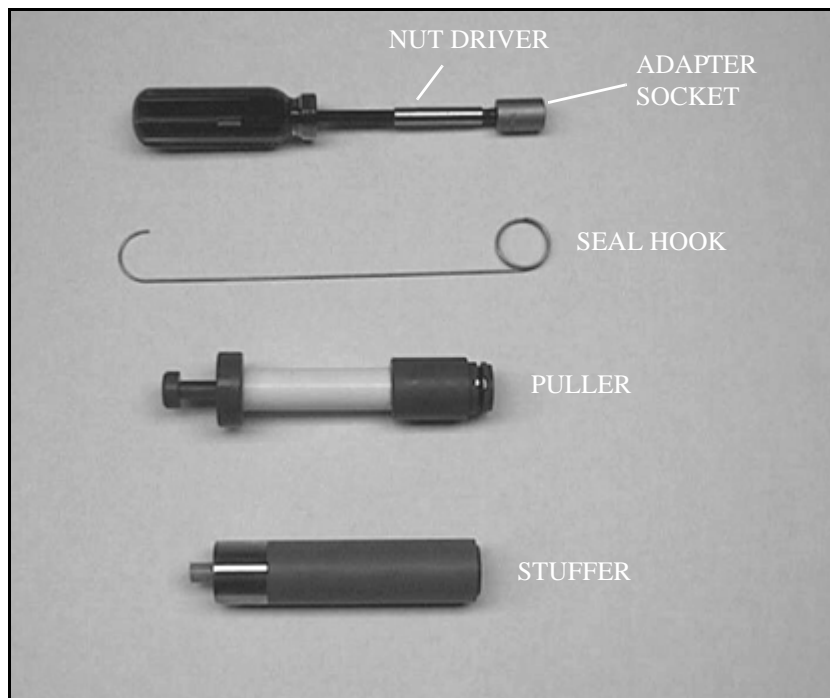

Tools Used in the Seal and Spacer Replacement

Nut Driver	#12664
Socket Adapter	#16906
Socket 7/16"	#12665
Seal Hook	#12874
Puller	#13061
Stuffer	#11098

All tools are a part of
the Service Repair Kit #60135-2510

Delayed Regeneration Timer Assembly (continued)

1. Turn off water supply to valve. Next, cycle valve to backwash position, then to service. Now remove electrical plug from outlet.
2. Remove control box cover.
3. Disconnect the brine line from the injector housing to the brine valve (if your unit has timed brine tank fill).
4. Remove the two capscrews that hold the back plate to the valve.
5. Grasp the back plate on both sides and slowly pull end plug and piston assembly out of the valve body, (see Fig. 1) and lay aside.
6. Remove the seal first using the wire hook with the finger loop (see Fig.2).
7. The spacer tool (use only for removing the spacers) has three retractable pins, retained by a rubber ring, at one end; they are retracted or pushed out by pulling or pushing the center button the opposite end.
8. Insert the pin end of the spacer tool into the valve body with the pins retracted (button pulled back). Push the tool tight against the spacer and push the button in, (see Fig. 3). When the button is pushed in, the pins are pushed out to engage the 1/4 dia. holes in the spacer. Remove the tool from the valve body. The spacer will be on the end. Pull the center button back, the pins will be retracted and the spacer can be removed from the spacer tool.

MODEL 2510 & 2510 ECONOMINDER

seal and spacer replacment

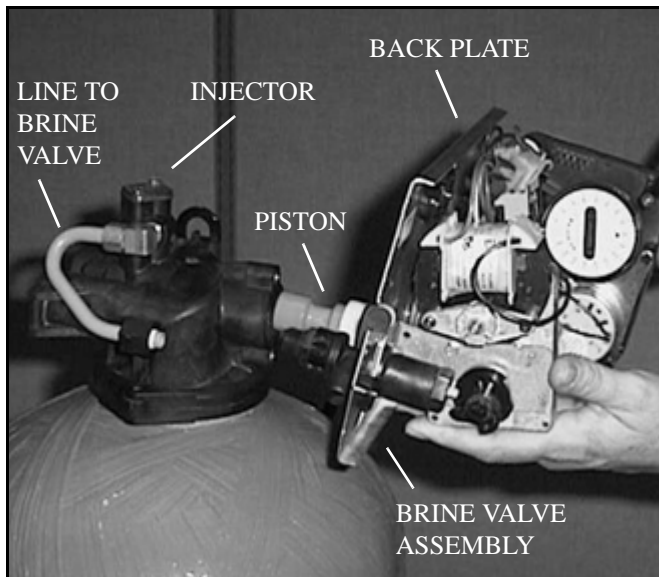

Figure 1 *Removing Power Head And Piston Assembly*

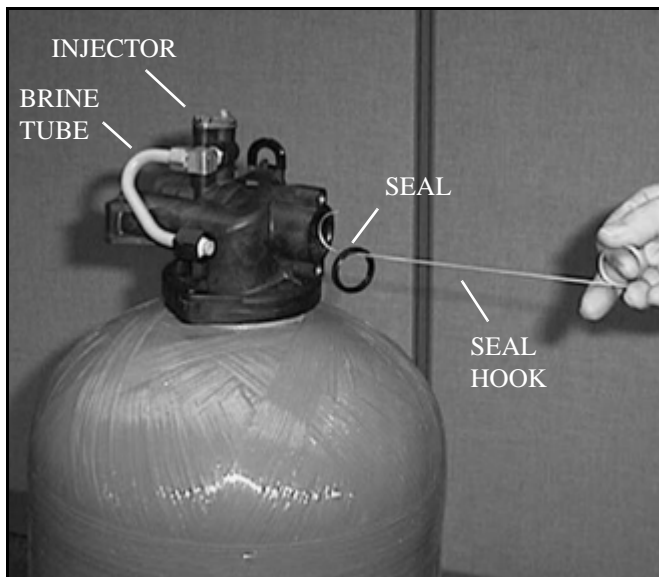

Figure 2 *Removing Special Tool From Valve Body After Inserting Seal*

9. Alternately remove the remaining seals and spacers in accordance with steps No. 6 and 8.
10. The last or end spacer does not have any holes for the pins of the spacer tool to engage, therefore if the end spacer does not come out on the first try, try again using the wire hook with the finger loop.
11. To replace seals, spacers and end ring, use special tool with the brass sleeve on one end. This is a double-purpose tool., (See Fig. 4). The male end acts as a pilot to hold the spacers as they are pushed into the valve body and the brass female end is used to insert the seals into the valve body.
12. To restuff a valve body, first take the end ring (the plastic or brass ring without holes), then with your thumb press the button on the brass sleeve end, the large dia. inner portion is now exposed (See Fig. 4). Place the end ring on this pilot with the lip on the end ring facing the tool, and push the tool into the valve body bore until it bottoms. While the tool is in the valve body, take a seal and press it into the inside diameter of the exposed brass female end (See Fig. 5).
13. Remove the tool, turn it end for end and insert it into the valve body bore. While holding the large dia. of the tool, slide it all the way into the valve body bore until it bottoms, then push the center button to push the seal of the tool and leave it in place in the valve body (See Fig. 6).
14. Remove the tool from the valve body and push the center on the brass female end to expose the pilot on the opposite end. Place a spacer on this end and insert the spacer and tool into the valve.

MODEL 2510 & 2510 ECONOMINDER

seal and spacer replacement (continued)

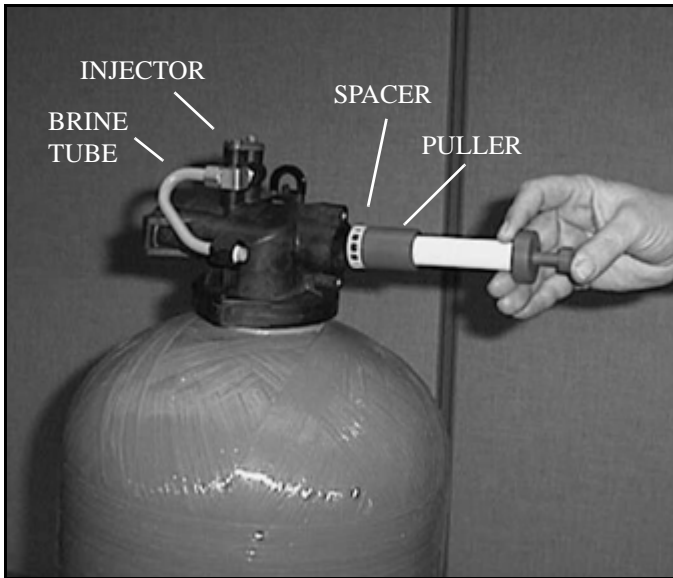

Figure 3 *Removing Spacer From Valve Body*

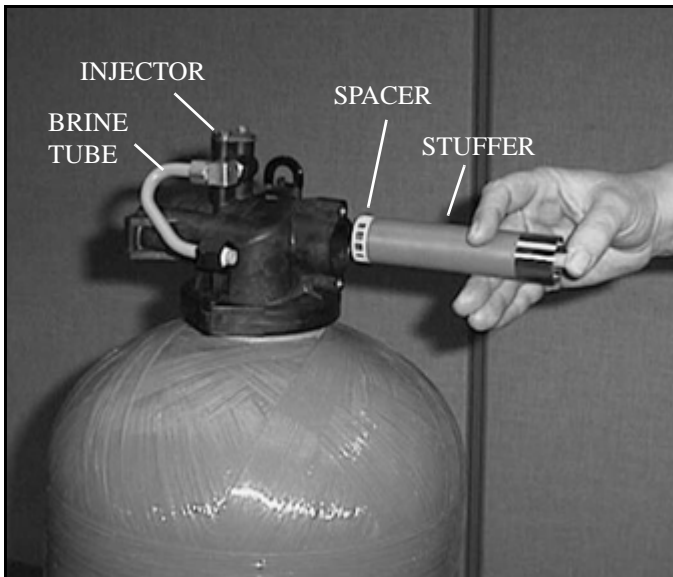

Figure 4 *Replacing Spacer In Valve Body*

15. While the tool is still in the valve, press another seal into the inside diameter of the exposed brass sleeve end.
16. Remove the stuffer, turn it end for end, and insert it into the valve body bore.
17. Alternately repeat steps No. 13 and 14 until all seals and spacers have been pushed into the valve (See valve cross section of your valve).
18. Place recommended silicone lubricant on the piston and inside the valve.
19. Hold the back plate with one hand and guide the piston into the valve body with the other hand, then grasp the back plate on both sides and slowly push the piston assembly and end plug assembly into the valve (See Fig. 1).
20. Replace the two PH screws to hold the back plate to the valve and tighten securely.
21. Connect the brine line from the injector housing to the brine valve (if your unit has timed brine tank fill).
22. Set the time of day dial to the correct time.
23. Replace the electrical plug in the outlet.
24. Turn on water supply.
25. Cycle control and check for proper function.
26. Check by-pass valve.