Dissertations, Theses, and Masters Projects

Theses, Dissertations, & Master Projects

1970

The Nail Making Industry in Early Virginia

John Tracy Keene

College of William & Mary - Arts & Sciences

CLICK ANYWHERE on THIS PAGE to RETURN to ANTIQUE NAIL & HARDWARE IDENTIFICATION at InspectApedia.com

Follow this and additional works at: <https://scholarworks.wm.edu/etd>



Part of the [Economic History Commons](#), and the [United States History Commons](#)

Recommended Citation

Keene, John Tracy, "The Nail Making Industry in Early Virginia" (1970). *Dissertations, Theses, and Masters Projects*. Paper 1539624706.

<https://dx.doi.org/doi:10.21220/s2-5k6z-he10>

This Thesis is brought to you for free and open access by the Theses, Dissertations, & Master Projects at W&M ScholarWorks. It has been accepted for inclusion in Dissertations, Theses, and Masters Projects by an authorized administrator of W&M ScholarWorks. For more information, please contact scholarworks@wm.edu.

THE NAIL MAKING INDUSTRY IN EARLY VIRGINIA

A Thesis

Presented to

The Faculty of the Department of History
The College of William and Mary in Virginia

In Partial Fulfillment

Of the Requirements for the Degree of
Master of Arts

By

John T. Keene, Jr.

1970

ProQuest Number: 10625138

All rights reserved

INFORMATION TO ALL USERS

The quality of this reproduction is dependent upon the quality of the copy submitted.

In the unlikely event that the author did not send a complete manuscript and there are missing pages, these will be noted. Also, if material had to be removed, a note will indicate the deletion.

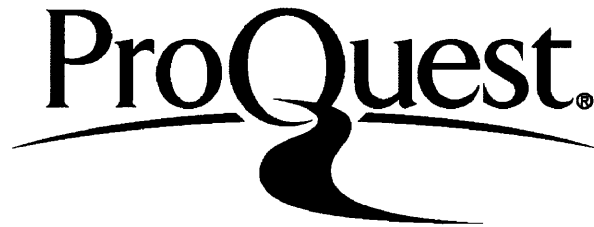

ProQuest 10625138

Published by ProQuest LLC (2017). Copyright of the Dissertation is held by the Author.

All rights reserved.

This work is protected against unauthorized copying under Title 17, United States Code
Microform Edition © ProQuest LLC.

ProQuest LLC.
789 East Eisenhower Parkway
P.O. Box 1346
Ann Arbor, MI 48106 - 1346

APPROVAL SHEET

This thesis is submitted in partial fulfillment

of the requirements for the degree of

Master of Arts

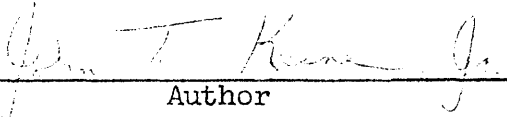

Author

Approved, May 1970

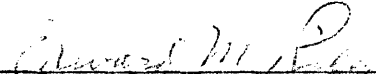

Edward M. Riley, Ph. D.



Richard M. Brown, Ph. D.

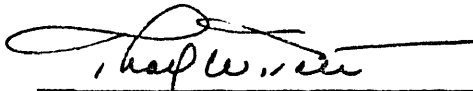

Thad W. Tate, Ph. D.

ACKNOWLEDGEMENTS

The writer wishes to express his appreciation to Mr. Paul Buchanan, Director of the Department of Architectural Research at Colonial Williamsburg, for his invaluable assistance in this endeavor. It was he who stimulated my initial interest in this subject, and whose guidance and criticisms proved most helpful throughout my investigation. To Mr. Raymond R. Townsend, Editor of The Chronicle of the Early American Industries Association, Inc., I am indebted for the loan of materials from his files on nails, nailmaking, and the tools of the nailer. Finally, for their careful reading and criticism of this manuscript, I would like to thank Professors Edward M. Riley, Richard M. Brown, and Thad W. Tate.

TABLE OF CONTENTS

	Page
ACKNOWLEDGMENTS.....	iii
LIST OF FIGURES.....	v
ABSTRACT.....	vi
CHAPTER I. INTRODUCTION.....	2
CHAPTER II. THE COLONIAL PERIOD.....	15
CHAPTER III. THE REVOLUTIONARY YEARS.....	25
CHAPTER IV. THE POST-WAR DECADES AND THE BEGINNINGS OF MECH- ANIZATION.....	34
APPENDIX I A GLOSSARY OF EIGHTEENTH-CENTURY NAIL TYPES AND SIZES.....	47
APPENDIX II A NOTE ON NAIL CLASSIFICATION.....	55
BIBLIOGRAPHY.....	57

LIST OF FIGURES

Figure		Following Page
I	Hand Wrought Nails.....	8
II	Tools of the Nailer.....	10
III	Early Nail Cutting Machinery.....	37
IV	Jefferson's Nailery at Monticello.....	39
V	Assorted Hand Wrought Nails.....	50

ABSTRACT

Nails are one of the least often studied of the necessities of colonial life. The production of wrought iron nails is not a complex industrial process. Any blacksmith could produce them in limited numbers, but the industry was slow in getting established in Virginia for a number of reasons. Most important among them was the Virginians' predilection towards the almost exclusive production of a saleable export crop. England supplied the bulk of Virginia's industrial imports, including nails. However, there was a small domestic nail making industry. Thomas Wyatt had a shop producing nails on the Eastern Shore as early as 1635. Smiths in Virginia's few towns, such as the Geddys in Williamsburg, made some nails. Some plantations had smithies equipped to produce nails, including Robert Carter's. Ironworks were being reestablished in the eighteenth century, and also contributed to the colony's limited production of nails.

The coming of the Revolution brought about a rapid realization of Virginia's excessive dependence on imports for nails and other vital commodities. Privateering and blockade running proved inadequate and unreliable methods of supply. As a stopgap measure, the state engaged James Anderson, a Williamsburg blacksmith, to operate a nailery. This met the immediate need with some success, but did little to establish the industry on a permanent footing, as it ceased operation in 1782.

Following the war, the British regained much of the Virginia nail market, but the coming of mechanization put Virginia in a better competitive position. It is somewhat ironic that Thomas Jefferson, the noted exponent of the virtues of agrarianism over industrial life, was one of the first to establish a commercial nailery with imported British machinery in 1794. His venture was not entirely successful, but it and a similar nailery, operated in conjunction with the Richmond penitentiary, were the precursors of an important nineteenth-century Virginia industry which established itself in such centers as Richmond, Wheeling and Lynchburg.

THE NAIL MAKING INDUSTRY IN EARLY VIRGINIA

CHAPTER I
INTRODUCTION

When European colonists first approached American shores in the early years of the seventeenth century, their motivations were many and varied. Yet Champlain at Port Royal off the Bay of Fundy and the Virginia Company settlers on Jamestown Island in Virginia faced the same basic problems. The chief obstacles to be overcome were environmental; the Europeans had to learn to adapt themselves to a new climate and to a world in which the only existing civilization was radically different from that which they had known in Europe. Survival was a real test, to be met by developing an adequate food supply and constructing suitable shelter.

Just what type of housing these first settlers constructed has been a subject of great interest to architectural historians. Only recently has there been some degree of consensus. The log cabin, certainly a logical choice because of the universal abundance of timber, was apparently not used widely until the eighteenth century. It appears to have been employed by only the Swedes in the Delaware Valley during the initial period of colonization, and only slowly adopted by other nationalities. Another rudimentary form of

¹Harold R. Shurtleff, The Log Cabin Myth: A Study of the Early Dwellings of the English Colonists in North America (Cambridge, Mass.: 1939), xxi, 243.

shelter is the wattle and daub cottage, such as have been reconstructed at Jamestown Festival Park. This type of construction was probably employed as a temporary expedient at best. Weather attacked the mud walls as soon as they were erected, and the thatch roofs were a constant fire hazard. Also, the first settlers were quite unprepared for coping with the American wilderness, unlike the celebrated frontiersmen of a later period, and clung to their European ways. Not unexpectedly, then, as soon as they were able, most settlers constructed homes similar to those they had left in England or on the Continent.

This was the pattern followed by settlers in Virginia. Very few years passed before heavy oak framed buildings or houses of native burned brick were being erected. This meant that there was a heavy importation of building materials which could not be or were not being produced locally, including glass, lead, ironware and stone. Perhaps most important of these was ironware--locks, casement window frames, hinges, tools and, of course, nails. A misapprehension of the type of architecture employed by early Virginians led several early students of Virginia economic history to conclude that few, if any, nails were
²
 needed by the early colonists.

Evidence to the contrary is actually quite abundant. For example, the Virginia Company, in addition to supplying tools and weapons to

²For example, Phillip A. Bruce, Economic History of Virginia in the Seventeenth Century (New York: 1907), II, 147.

tenants sent to cultivate the public lands, also provided nails of many sizes.³ Robert Evelyn, a mid-seventeenth-century Virginian, compiled a list of necessities every immigrant should bring. It included merchandise to sell for cattle, provisions, seed, tools, weapons, ammunition,⁴ and nails. Edvard Williams, author of Virginia Richly Valued⁵ (London: 1650), a promotion pamphlet, included a similar list.

The practice of proprietors' providing nails to help their tenants get established was a tradition which did not die with the Virginia Company in 1624. French Huguenot refugees being settled on the Northern Neck were offered enough nails and hardware to build a home twenty-six feet to twenty-eight feet by fourteen feet to sixteen feet in 1687,⁶ while William Fitzhugh also provided his new tenants with nails in 1690.⁷ An advertisement in the Virginia Gazette in 1736 offered prospective freeholders willing to remove to Georgia enough nails to build a house sixteen feet by twenty-four feet.⁸

That proprietors should offer to supply nails to tenants clearly indicates that they considered nails a necessity for establishing

³Ibid., I, 233. Bruce himself provides this evidence to contradict his own thesis.

⁴Ibid., I, 339.

⁵Williams, cited by Bruce, ibid.

⁶Tyler's Quarterly Historical and Genealogical Magazine, V, No. 3 (January, 1924), 168.

⁷Virginia Magazine of History and Biography, III, No. 1 (1895), 8.

⁸Virginia Gazette (Williamsburg), 10 September 1736, 4, Col. 2.

a homestead and farm. But for the freeholder who did not have his necessities provided him, procuring nails was from the first a very expensive operation. The Minutes of the Council and General Court for 1626 record a conversation which had passed between Henry Elyott and Richard Crocker the previous March. Elyott, it seems, commented that John Day of Hog Island sold nails for a barrel of ears (of corn) a thousand, but would do so no more because Captain Hamor sold nails for a barrel of corn and ten pounds of tobacco a thousand. Crocker replied that two of them (Captain Hamor and Mr. Persey) were unfit to sit at the council table because they dealt upon nothing but extortion.⁹ Crocker, needless to say, was severely punished for his rash talk.¹⁰

Colonial officials were at least cognizant of the problem, and the 1640's record two attempts to deal with it. The sixth act passed by the General Assembly which sat in March 1642/43 attempted to prevent the excessive and exorbitant engrossing of certain commodities brought into the colony. Nails were among the enumerated items which were forbidden to be sold at a higher rate than that at which they were imported.¹¹

An act passed in the session which met in February of the following year indicates that the Virginians were most resourceful in procuring nails for their personal use, although this did not always serve

⁹Virginia Magazine, XVII, No. 2 (1919), 145.

¹⁰Ibid.

¹¹William W. Hening, ed., The Statutes at Large; Being a Collection of All the Laws of Virginia (Richmond: 1810), I, 245.

to promote the general welfare:

It shall not be lawful for any person so deserting his plantation as aforesaid to burne any necessary houseing that are scituated thereupon, but shall receive so many nailes as may be computed by 2 indifferent men were expended in the building thereof for full satisfaction. . . .¹²

Thereafter, the burning of buildings for nails, in theory at least, required specific authorization. Such permission was granted to the person who would occupy the site on the James River opposite the unused Fort Charles in 1646. He was to be allowed to enjoy the housing of the fort for timber, or burning them for nails or otherwise.¹³ Nor was this practice restricted to Virginia, for when a new courthouse was authorized for Kent County, Delaware, in 1691, it was also resolved that ". . . wee doe alsoe Concent that ye old Courthouse may be burnt to gett the nailes."¹⁴

Another indication of the importance of nails is that they were a medium of exchange in early Virginia. In the early 1640's a court order was issued for Roger John, a Northampton County blacksmith, to pay L 7 10s and 1900 nails to William Sterens, a boatwright.¹⁵ Occasionally nails even crept into transactions as late as the early eighteenth century. For example, in 1709, John Custis III purchased five hundred acres of land on Chincoteague Island in Accomack County

¹²Ibid., I, 291.

¹³Ibid., I, 327.

¹⁴Charles E. Peterson, "Burning Buildings for Nails," Journal of the Society of Architectural Historians, IX, No. 3 (October, 1950), 23.

¹⁵Susie M. Ames, Studies of the Virginia Eastern Shore in the Seventeenth Century (Richmond: 1940), 126-127.

for a like amount of land in another part of the county and ten thousand
¹⁶
 nails.

With nails in such short supply and so expensive when imported, it should not be surprising that Virginians should attempt to produce this relatively simple article for themselves. Iron, it should be noted, was one of Jamestown's first exports to England during the period when the colony was seeking a profitable export to sustain the venture. The first full-scale ironworks in America was constructed on Falling Creek approximately sixty miles above Jamestown in 1619, and were expanded in 1622. Unfortunately, the Indians in that year destroyed
¹⁷
 the works and massacred the workers. Because of the capital required, no other substantial ironworks were built in the colony until the eighteenth century. Nevertheless, some ore was refined by the bloomery
¹⁸
 process throughout the rest of the century.

Whether native iron was used to produce nails in the young colony is at this time an unanswerable question, for imported nail rods could also have been employed. Few records exist of the production of nails themselves. One of the earliest producers thus far discovered was Thomas Wyatt of Northampton County on the Eastern Shore, who was producing

¹⁶Accomack Wills 1692-1715, Part II, 445-46, cited by Ames, Virginia Eastern Shore, 34.

¹⁷J. Leander Bishop, A History of American Manufactures From 1608 to 1860, 3rd. ed. (Philadelphia:1868), I, 28-29.

¹⁸Harold B. Gill, "The Blacksmith in Colonial Virginia," Colonial Williamsburg Research Department Report (1965), 6-8.

nails in his shop in 1635.¹⁹ Two years later the Northampton court ordered John Parramore to pay Wyatt for 2,000 four-penny nails, 1,700 six-penny nails, 140 three-penny nails, and 820 two-penny nails,²⁰ so apparently Wyatt ran a fairly sizable operation.

The operations used by Wyatt in his nail production, although not specifically recorded, are not difficult to determine. Albert Sonn reports that a nail found in the Roman Forum was indistinguishable from one taken from a 1724 Wethersfield, Connecticut house,²¹ reflecting that the craft remained basically unchanged from ancient times until the first introduction of nail cutting and nail making machinery in the closing years of the eighteenth century. The necessities were few and simple--a small anvil with a tapered swage hole on the horn, a hammer with a cross peen for cutting the nail rod, tongs to hold the hot rod, and a small fire which did not even require a forced draft. "Few blacksmith shops were so specialized as not to make carpenter's nails."²²

Adam Smith, however, points out that by far the most efficient nail making came from shops devoted exclusively to the craft. He

¹⁹Northampton County Records, I, 48, cited by Ames, Virginia Eastern Shore, 127.

²⁰Ibid., I, 67, in Ames, Virginia Eastern Shore, 127.

²¹Albert H. Sonn, Early American Wrought Iron (New York: 1928), I, 4.

²²Edward Tunis, Colonial Craftsmen and the Beginnings of American Industry (Cleveland, Ohio: 1965), 58.

FIGURE I
HAND WROUGHT NAILS

Rose Heads

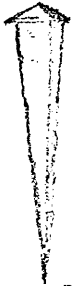

fine drawn
point

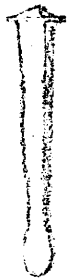

flat
point

Lath Nail



T-head

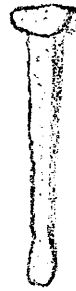

Cast Nail

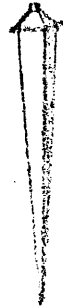

L-heads or Sprigs

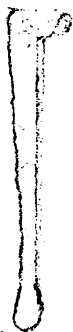

Trim nails

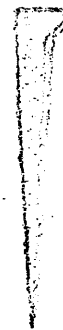
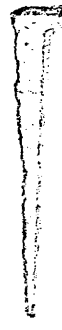
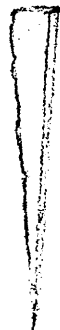
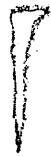

Flooring nails

Adapted from: Lee H.
Nelson, Nail Chronology
as an Aid to Dating Old
Buildings (Nashville,
Tennessee: 1963), 1.

estimated that a common smith unused to the trade could produce but 200-300 nails per day--and very poor ones at that. A smith accustomed to making nails as a side line fared better--his daily production would average between 800-1,000 nails. However, boys under twenty, trained exclusively in the trade, could by exertion produce up to 2,300 nails per day.²³

The basic raw material was nail rod, strips of soft and malleable forged iron, varying from one-eighth of an inch to one-fourth of an inch square, depending on the size of nails being made, and approximately five feet long. Except for the smallest nails, the rod had first to be heated. Then the heated end would be pointed either on four sides, to produce a fine point, or on two to produce a flat point. The rod would then be partially cut by a hammer blow, the pointed end put in the swage hole, and the rest of the rod broken off and placed back in the fire. The projecting end of the nail was then hammered down and spread around the hole, forming a head. The cooling nail was then knocked from the swage hole. Rivets were made in a similar manner, except the swage hole was round instead of square.²⁴ Depending upon the use for which the nail was intended, rose heads (four or more facets), T-heads, or L-heads could be formed.

²³Adam Smith, The Wealth of Nations, cited by Harry B. Weiss and Grace M. Weiss, Forgotten Mills of Early New Jersey (Trenton, New Jersey: 1960), 65.

²⁴Weiss and Weiss, Forgotten Mills, 63.

One improvement which came into common use by the late 1700's was the hand-held nail header. Grasped in the left hand, headers replaced the swage hole in the anvil and could be simply inverted and tapped to release the headed nail. Another form of nail header could be held in a bench vise.²⁵ These are simply the most rudimentary form of the craft. A wide variety of tools were actually available to the nail maker, particularly by the late eighteenth century, yet all were actually quite simple variations on the devices here described. Diderot's Encyclopedie illustrates some slightly more sophisticated tools employed by French nail makers of the period, but few similar examples have thus far been discovered in America.²⁶

For the general smith, nail rod proved a handy item to have in his shop for jobs in addition to nail making. Cooper's cressets or fire baskets, gridirons, trivets, spits for reflector ovens, meat hooks, grappling hooks, and quarrying tools are among the products a versatile smith could fashion from nail rods.²⁷

While everywhere the nail making process was essentially the same, there still were regional variations. In the northern colonies, nail making was a household industry in which the whole family participated

²⁵See illustration of spring nail header, following.

²⁶J. Didsbury, "The French Method of Nail-Making," The Chronicle XII, No. 4 (December, 1959), 47.

²⁷Lawrence S. Cooke, "Nail Rod and Some of its By-Products," The Chronicle, XIV, No. 1 (March, 1961), 6-7.

FIGURE II
TOOLS OF THE NAILER

Adapted from: Eric Sloane,
A Museum of Early American Tools (New York: 1964),
90-93.

TOOLS OF THE NAILER

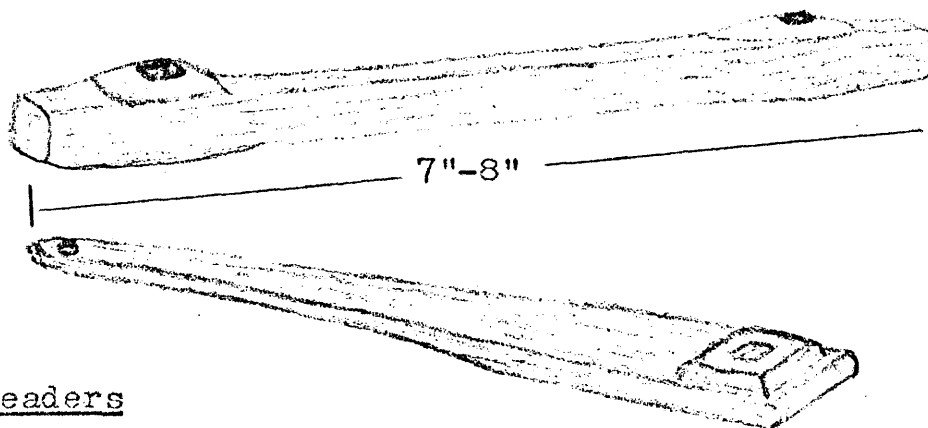

Hand-held nail headers

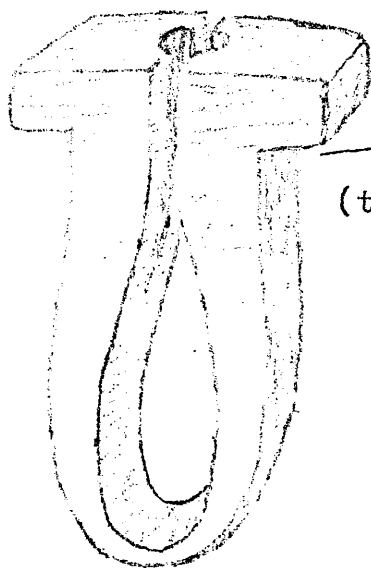

A spring nail header
(to be clamped in a vise)

Hardy or hack iron

Swage hole

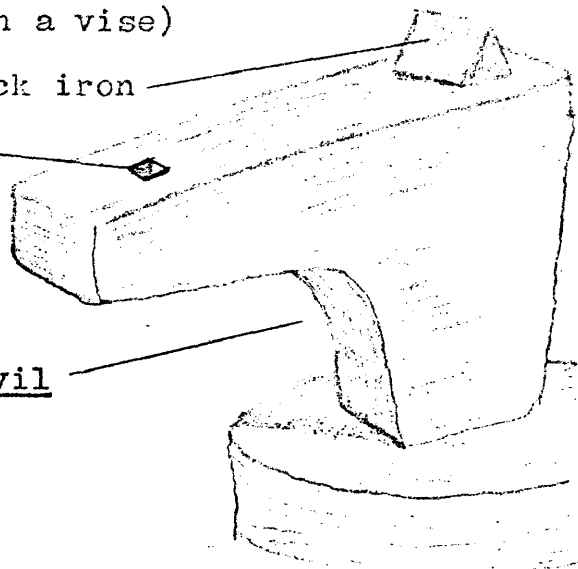

Nailer's anvil

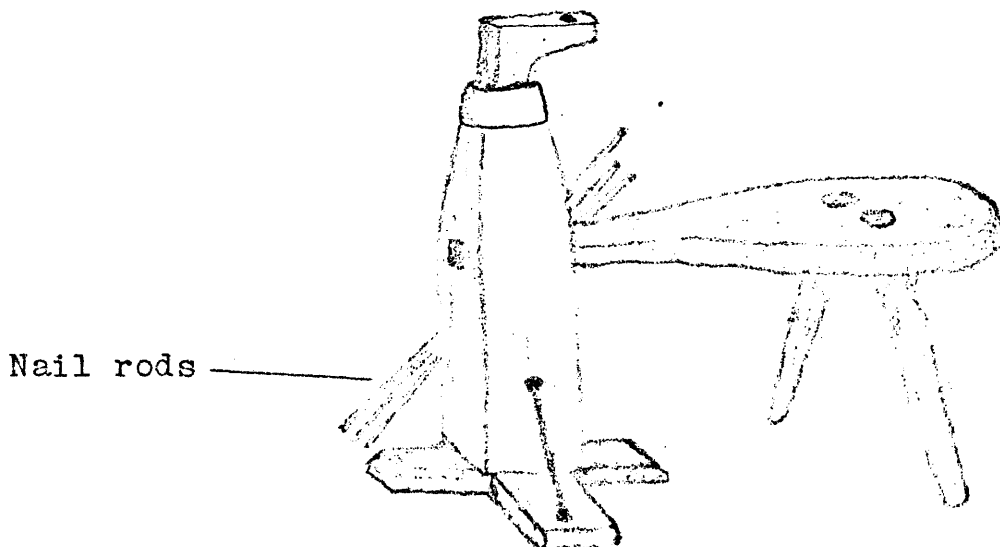

Nail rods

Nailer's
Anvil Bench

TOOLS OF THE NAILER (con't.)

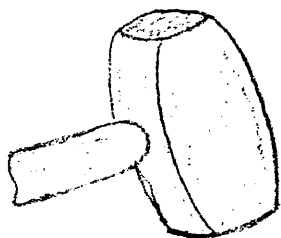

Pointed nail rod cut by hammering on a hardy, then put into a header (cross section)

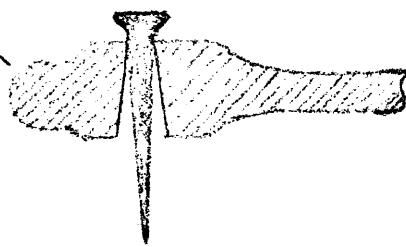
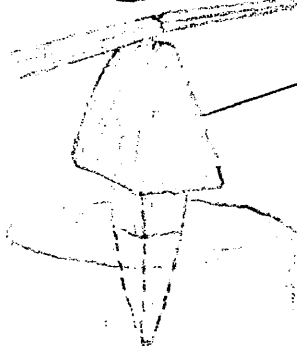

Smith's tongs

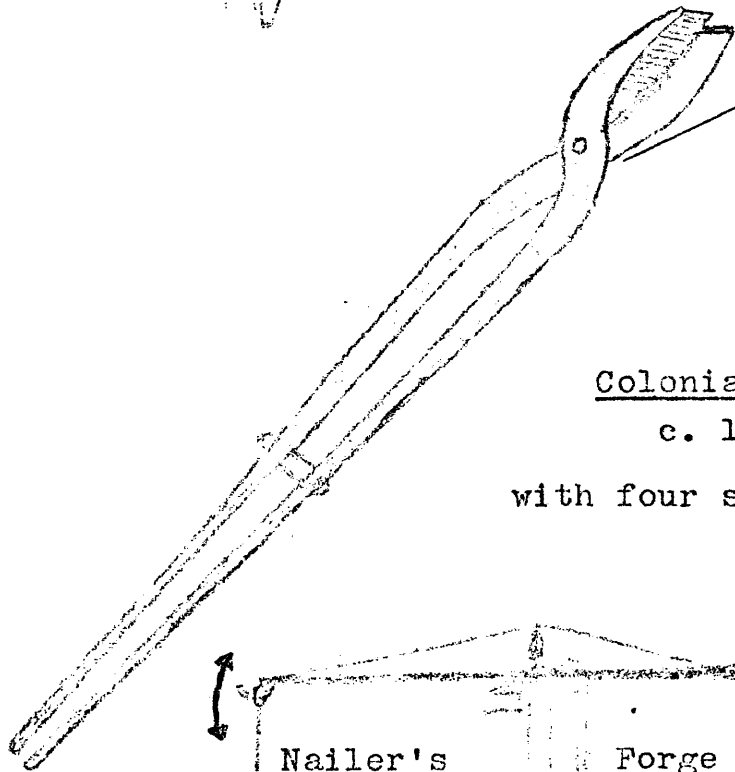

Colonial anvil

c. 1650

with four swage holes

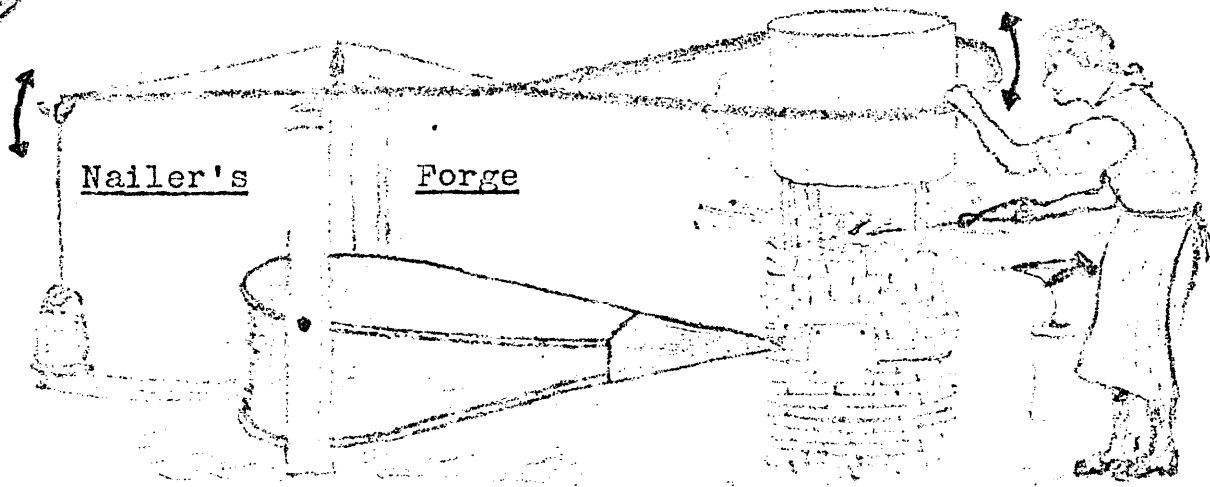
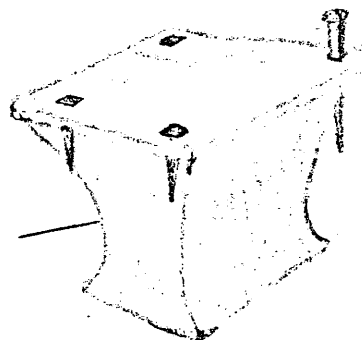

during the long winter months. Each fall a supply of nail rod would be obtained, and with the kitchen hearth serving as a forge the evenings would pass to the tune of hammer blows on a small anvil. If resources were short, scrap iron would be employed in place of the nail rod. The product of the winter's work could be used for spring repairs and summer construction on the farm, and the surplus sold for profit. Although the domestic manufacture of nails was common throughout New England and to a lesser extent even as far south as New Jersey, Plymouth and Bristol Counties in Massachusetts and Litchfield County in Connecticut were early centers of the trade. The nail making industry is the only metal working occupation which was so centralized during the handicraft period. When nail making became mechanized, eastern Massachusetts, not surprisingly, was a leading center of the industry.

While in New England nail making was principally a household industry, the mother country had centralized nail making to such a degree that the industry vitally affected the economy of one entire region. It is estimated that during the late colonial period there were 60,000 nailers in the vicinity of Birmingham alone. Mechanization came no earlier than in America, so very large numbers of nailers were employed. It is estimated that approximately half of the British

²⁸Victor S. Clark, History of Manufactures in the United States (New York: 1949), I, 516.

²⁹Weiss and Weiss, Forgotten Mills, 65.

production of wrought iron during the colonial period was consumed by the nail making industry. Thus when the colonial production of nails began to capture the American market, the nailers were among the most vigorous supporters of the Iron Act of 1750, which restricted colonial iron production to only bar iron--any further manufacturing or refining into steel was to be done in England. The Iron Act seems to have had little practical effect, however; market forces ruled. Small nails and tacks were supplied principally by British nailers, since their labor was cheaper, but by the Revolutionary period native nailers were making significant inroads into the spike and larger nail trade.³⁰

With such a large demand coming from the American market, the British industry was highly responsive to changes in that demand. The colonial press reflected the effects of this quite vividly; for example, the Virginia Gazette of September 1, 1738 carried news of a disturbance in Worcestershire:

. . . above a Thousand Nailors got together, and went to the Ironmongers in and near that place (Stowerbridge), and Birmingham, and obliged them to sign a Paper to give them an advance in Price in Nails, being half starved for want of Work and Price, and threatened to come again in a Month's Time to see it complied with. The small Demand from our Plantations, has caused them to have such a large Stock in Hand, that many in Trade will be glad to part with their Nails for little or no Profit, to enable them to employ their workmen. This is the second time they rose within these four Months, and threatened to pull down the Houses of those who did not comply.³¹

³⁰Clark, History of Manufactures, I, 222.

³¹Virginia Gazette (Williamsburg), 1 September 1738, 3, col. 1.

During the turbulent years following the Peace of Paris in 1763, the British thought they could see duplicity in colonial actions as they were flooded with orders for nails. This account comes from London, and is dated April 4, 1767:

Would you believe it? At this juncture, when these people are complaining of the want of cash to pay their old debts, they have sent over orders; yes, and money with orders, for greater quantities of nails for all kinds of building than was ever known before: And it is impossible to execute the orders that have been sent, for many months to come. Now, preparations for buildings are signs of wealth in Europe; but it seems they are the signs of poverty, or want of cash in America. However, as we make nails cheaper than any nation upon earth, they condescend to become our customers on that account; but as to other articles such as silks, velvets, thread laces, gold and silver laces, silk stockings &c, &c, they deal with the French so much for ready money that they can, and sometimes do, import such goods cheaper here from America than they can be made in England.³²

Clearly, however, this was less distressing to the British ironmongers than the lack of business resulting from colonial embargoes on British manufactures:

It is certain that three thousand persons in the nail-making business are out of employment, and two thousand more are soon expected to be in the same condition, entirely owing to our unhappy differences with America.³³

These digressions are intended to serve as a contrast to the pattern of development of the nail making industry in Virginia, and to demonstrate that although the colonial nail making industry was making

³²Purdie and Dixon, Virginia Gazette (Williamsburg), 18 June 1767, 1, col. 1.

³³Dixon and Hunter, Virginia Gazette (Williamsburg), 4 November 1775, 2, col. 1.

inroads into the market formerly monopolized by the British, the ironmongers of Birmingham and Worcestershire were still serious competitors, even into the early nineteenth century.

CHAPTER II

THE COLONIAL PERIOD

Harry B. and Grace M. Weiss, in their study Trades and Tradesmen of Colonial New Jersey, point out one of the basic problems in studying the early nail making industry: "Nailers during colonial days seldom received public attention unless they were runaways or got into trouble of some sort."³⁴ Yet, in addition to this general shortage of information on the trade, the Iron Act of 1750 induced colonial nailers to avoid publicizing their illegal activities. As a result, material on early Virginia nail making is fragmentary at best.

The record of Thomas Wyatt's shop of 1635 on the Eastern Shore, previously mentioned, seems to indicate that nail making was his principal occupation. However, it could be that his was a blacksmith's shop which happened to produce nails for local customers. In any case, records of such specialized shops do not appear again in Virginia until the mid-eighteenth century. Thus, unlike the English pattern, nail making was not a geographically centered or distinct trade in Virginia.

Apparently, however, the household industry of nail making by farm families was also small or non-existent. What nail making

³⁴Harry B. Weiss and Grace M. Weiss, Trades and Tradesmen of Colonial New Jersey (Trenton, New Jersey: 1965), 88.

was done in Virginia was primarily the product of the local or plantation blacksmith. In the early years of the colony, men of many trades were brought over in an attempt to provide the community with all necessary services. Nailers were not listed among them, but blacksmiths were. George Read arrived with the 1607 settlers. Richard Dole followed in 1608, and in 1611 Governor Dale reported the construction of a smith's forge at Jamestown. However, with only a few smiths to repair all the ironwork in the colony and fabricate some of it, there was probably little enough time to produce nails on a large scale. Harold Gill, in his recent study of the blacksmith in Colonial Virginia, reaches this conclusion: "The work of most seventeenth-century smiths was evidently confined to repairing broken articles and making small tools. Iron work for special construction was usually imported."³⁵

Such was apparently the case when York County built a new prison, for the county record of disbursements for 1647 has Captain John Chisman being paid 150 pounds of tobacco". . . for lockes keyes & nayles for y^e prison laste years."³⁶ Although it is possible Chisman was a local militia officer, it is more likely he was master of a ship.

³⁵Gill, "The Blacksmith," 19.

³⁶William and Mary Quarterly (Series 1), XXIII, No. 4 (1915), 273.

There are much less ambiguous records of the production of local smiths, but none quite as early as the Chisman record above. However, in 1742, Thomas Jones was billed two shillings sixpence by Hugh Orr, Williamsburg's first known blacksmith, for "18 Tyer Nails for ye wagon."³⁷ In August of 1751, David and William Geddy, smiths of Williamsburg, advertised that they carried on founders' work including hinges, squares, nails, and bullions.³⁸ Although this might seem to indicate the Geddys were producing cast nails, a relatively uncommon type in America, they probably made the more common wrought iron type. The Geddys also illustrate the multiple talents of colonial nail makers, for they are best remembered as gunsmiths and as armourers for the colony.

Not all Virginia smiths, however, were as well established as the Geddys. Lack of towns meant that most smiths in the colony worked on plantations by the eighteenth century, and since plantations sought cheap labor, these were most often indentured servants, or by the early eighteenth-century, slaves.

Because of lack of money, as well as other handicaps to the success of craftsmen, most blacksmiths who followed their trade in Virginia, especially during the seventeenth and first half of the eighteenth century, were indentured servants who operated plantation smithies.³⁹

Merely because the majority of smithies were on plantations during the colonial period, it should not be assumed that this meant a general

³⁷Jones Family Papers, Item No. 652 (Library of Congress), cited by Gill, "The Blacksmith," 62.

³⁸Virginia Gazette (Williamsburg), 5 August 1751, 3, col. 2.

³⁹Gill, "The Blacksmith," 26.

lack of commercial smithies. Only the largest of plantations could afford to maintain their own blacksmith, and even then it was often difficult to find enough to keep this man fully occupied. A planter thus would be not at all reticent to allow his smith to perform work for his neighbors on a commission basis. If even this proved to be insufficient to keep the smith busy, nail making was a perfect answer, for nails were always needed, and the surplus could be sold with no trouble. A slave blacksmith who could produce nails had much to recommend him as a purchase, and could command top prices; as the following advertisement illustrates:

For sale, for ready money or 12 months credit, an exceeding good plantation BLACKSMITH, who is very well acquainted with many other kinds of work in that branch of business, such as nail making, tiring wheels &c. . . .⁴⁰

Robert Carter of Nomini Hall was one of Virginia's more prominent planters who maintained a nailery. He was also one of the more progressive planters of the colony, being one of the first to shift from tobacco growing to the production of foodstuffs for the export trade. In addition, Carter was interested in America's infant manufactures, and held a significant interest in the Baltimore Iron Works, from which he probably obtained his nail rod. His nailery must have had a fairly

⁴⁰Purdie, Virginia Gazette (Williamsburg), 6 June 1777, 3, col. 1.

substantial output, for it is recorded that he shipped nails to London in quantity when the price was good.⁴¹ This was most certainly a reversal of normal trade patterns.

One additional source for nails was Virginia's infant ironworks which were beginning to reappear in the eighteenth century. The Accokeek Iron Works, operated by Nathaniel Chapman in Stafford County, was established in response to 1727 and 1729 Acts for Encouraging Adventurers in Iron Works.⁴² In 1731, Chapman sold John Mercer of Marlborough, Virginia several hundred nails of various sizes and types.⁴³ Chapman produced iron utensils and farm implements in addition to nails from native ores at this same site.

Virginia always faced a shortage of blacksmiths because of competition from other pursuits. Many young European smiths would accept an indenture to obtain passage to America. Yet, when their terms expired, most found the lure of the land too strong--they abandoned the trade in favor of establishing a homestead and becoming a farmer. Jefferson noted this allurements of the land even as late as the post-Revolutionary period:

⁴¹Louis Morton, Robert Carter of Nomini Hall (Williamsburg, Virginia: 1945), 171.

⁴²Hening, Statutes, IV, 228-231, 296-300.

⁴³C. Malcolm Watkins, The Cultural History of Marlborough, Virginia (Washington, D. C.: 1968), 25.

Such is our attachment to agriculture, and such our preference for foreign manufactures, that be it wise or unwise, our people will certainly return as soon as they can, to the raising of raw materials, and exchanging them for finer manufactures than they are able to execute for themselves.⁴⁴

Because of this combination of circumstances, Virginia during the colonial period could produce but a small percentage of the nails she needed. The remainder were imported largely, but not exclusively, from England. The Netherlands, France, Pennsylvania, and the New England colonies were all direct or indirect suppliers of Virginia planters.

To obtain some idea of the dynamic life of the colony, one need only look at some plantation records or personal inventories of the period. The quantities of nails found in nearly every case indicate that the gross product of the colony, if it could have been measured, would probably have been rising at a rapid rate throughout most of the eighteenth century at least.

When a master was filling out his general cargo for sale at the various Virginia plantations, nails usually held a prominent position in the manifest, and the return was seldom disappointing. The accounts of the Tristram and Jane of London, which voyaged to Virginia in 1637, recorded under "Certaine goods sould out of the generall cargozoune (cargo)" 36,000 6d nails, 5,500 10d nails, 2 firkins (small casks) of 10d nails, and 1,000 20d nails.⁴⁵

⁴⁴Thomas Jefferson, Notes on the State of Virginia, ed. by William Peden (Chapel Hill, North Carolina: 1955), 164.

⁴⁵Virginia Magazine, LXII, No. 4 (1954), 417.

Large shipments were not uncommon even as early as the mid-seventeenth century. Witness a 1644 invoice of goods shipped aboard the Sivilla and consigned to Adam Bland, Peter Burr, and John Jewell: 46

A barrell with 23,000 of 6d. nails at 3s. 10d.	L 4 18s. 4d.
A firkin with 30,000 of 4d. nails at 3s. 17d.	L 2 13s. 9d.
A firkin with 32,000 of 3d. nails at 3s. 16d.	L 2 5s. 4d.
A firkin with 6,000 of 10d. nails at 3s. 4d.	L 1 18s. 0d.
A firkin with 4,000 of 20d. nails at 10s. 3d.	L 2 1s. 0d.
	L13 16s. 5d.

William Fitzhugh was one planter who seldom sent an order without including nails among the desired commodities, nor were they always of English manufacture. In a letter to Jonathan Cooper dated March 30, 1684, he notes that he received all the goods ordered except the Dutch nails and tacks, which he presumed had been omitted in packing. 47

In 1695, he wrote John Taylor, a London merchant, informing him that he had sent thirteen hogsheads of tobacco consigned to him,

. . . which I hope will come to good Market, this come now to desire you to serve me in goods for what I shall have in your hands after the sail of the said Tob^o; let it be in Nails, hoes, axes, kerseys, cotton, and other coarse goods.⁴⁸

By his selection of "coarse Goods" one might presume that he had an eye towards the possible resale of these standard staples.

In the eighteenth century, merchants became established in Virginia, and large quantities of nails were consigned to them for distribution. Francis Jerdone, a Yorktown merchant, made numerous entries of nails of

⁴⁶Ibid., LXXII, No. 1 (1964), 34.

⁴⁷Ibid., I, No. 3 (1894), 268.

⁴⁸Ibid., V, No. 1 (1897), 32.

all sizes in his Cargo Waste Book for 1748-1749. Roger Dixon of
 Fredericksburg advertised European nails.⁴⁹ Henry Fleming of
 Fisher, Bragg and Company of Norfolk announced to the public the
 arrival of a shipment including nails from Whitehaven.⁵⁰ Business
 must have been brisk, for less than a year later, Fisher Bragg, and
 Fleming (the home office had apparently been pleased enough with the
 latter's performance to make him a partner) announced another shipment
 of nails from their Whitehaven warehouse.⁵¹ Edward Brisbane, a Peters-
 burg merchant, offered favorable credit for his nails in 1768 if accom-
 panied by a moderate advance, and would accept payment in crop tobacco
 at any James River warehouse.⁵² Dutch and French nails, mostly imported
 via the West Indies, did not enter in large quantities until the
 Revolutionary years.

Fewer records exist for American nails, but for the South Patowmack
 District in 1766, the schooner Patowmack is entered as inbound with four
 casks and three kegs of nails from Philadelphia.⁵³ That November the

⁴⁹Purdie and Dixon, Virginia Gazette (Williamsburg), 25 April 1766,
 3, col. 1.

⁵⁰Ibid., 22 November 1770, 3, col. 1.

⁵¹Ibid., 8 August 1771, 2, col. 3.

⁵²Ibid., 6 October 1768, 2, col. 3.

⁵³Rind, Virginia Gazette (Williamsburg), 18 July 1766, 3, col. 2.

sloop Sally from Maryland entered the Port of Accomack with six casks of nails, but cleared outwards three days later with nine.⁵⁴ This probably indicates that nails were a useful commodity in barter rather than that Virginia was producing nails for export.

London merchants still did some direct business with large and small customers alike, as the records of John Norton & Sons indicate. In 1770 John Robinson of York County ordered 147,000 nails and brads of varying sizes,⁵⁵ while the following year George Wythe of Williamsburg ordered a single cask of nails.⁵⁶

Nails were apparently an important item in the coastwise trade from New England, which in turn bought much of its nail rod from Philadelphia. Old ironware would be bought for scrap from Tidewater plantations and refined and recast into new implements for sale in the South and the West Indies. Nails and furniture were among the staples in this trade.

The nails Virginians used during the colonial period, then, came from a wide variety of sources. Planters like Robert Carter, however, who had a separate nail store, well filled from his own nailery, were certainly the exception. It seems from the fragmentary evidence available that most of Virginia's nails before the Revolution were imported.

⁵⁴Ibid., 25 December 1766, 1, col. 3.

⁵⁵Frances N. Mason, ed., John Norton & Sons: Merchants of London and Virginia (Richmond, Virginia: 1937), 119.

⁵⁶Ibid., 169.

Acting Governor John Blair affirmed this in his report to the Lords of Trade in September, 1768:

Our pig-iron and some bar iron is chiefly shipped to Britain. We do not make a saw, augur, gimlet, files, or nails, nor steel; and most tools in this country are imported from Britain . . .⁵⁷

This might be considered suspect because of its being dated after the passage of the Iron Act of 1750, but Lieutenant Governor Gooch, whose term ended in 1749, made much the same answer in response to the query concerning what British manufactures were imported and in what quantities: " . . . all manner of Iron Ware such as Locks, Hinges, Nails, Carpenters, Joyners, and Smiths Tools, Axes, Fire Armes, and Small Anchors."⁵⁸

Governor Francis Fauquier also concurred, for about 1760 he expressed his belief that Virginians could import goods more cheaply⁵⁹ than they could manufacture them domestically.

⁵⁷ Acting Governor John Blair to Lords of Trade, 20 September 1768, cited by Alonzo T. Dill, "A Documentary History of the Governor's House at New Bern, N. C.," submitted to Perry, Shaw, Hepburn, Kehoe, and Dean, Architects (1953), 77.

⁵⁸ Virginia Magazine, III, No. 2 (1895-1896), 117.

⁵⁹ Francis Fauquier, cited by Robert E. and B. Katherine Brown, Virginia 1705-1786: Democracy or Aristocracy? (East Lansing, Michigan: 1964), 9.

CHAPTER III

THE REVOLUTIONARY YEARS

It was the onset of the Revolution which spurred Virginians to take an objective look at their largely neglected manufactures. Only the iron industry had made significant progress before the war. However, in March of 1775, a convention was held in Richmond to elect delegates to the upcoming Continental Congress. They appointed a committee to prepare plans for the encouraging of arts and manufactures. That committee in its report recommended unanimously that the manufacture of iron into nails, wire, and other necessary articles be undertaken.⁶⁰ Indicative of the importance placed upon nail manufacture was its location between resolutions calling for the manufacture of gunpowder and steel.

The impending breach with Britain inspired nationalistic feeling of many kinds, including hostility to imperial trade restrictions, as evidenced by this letter to Alexander Purdie, editor of the Virginia Gazette, early in 1776:

Much has been said concerning the independence of the colonies, and some people have been made to believe that such a state is not desirable, and that we should wish for no more liberty than we enjoyed in 1763; but let any man consider that,

⁶⁰Pinkney, Virginia Gazette (Williamsburg), 30 March 1775, 3, col. 1

at that time, we were restrained from making nails and hats, and might with equal justice have been hindered from building houses or making stockings; that we were cruelly and wantonly restricted in our trade, in some instances, as it were merely to show we were the slaves of Britain.

61

- An AMERICAN -

William Pitt, the colonist's champion in Parliament, also recognized their plight, for he is said to have stated "if the horse flung a shoe, an American could not, of right, so much as make the nails required to set it".⁶²

Effective measures were taken immediately by the county Committees of Correspondence throughout Virginia. One of their most important duties was to see that nonimportation agreements were complied with, and apparently the agreements did operate with a good deal of effectiveness. As early as February 1775 an announcement was published informing the public that sundry goods, including nails and smith's tools, were to be sold by order of the Elizabeth City County Committee.⁶³

Committees also exercised control over prices in order to insure that no excessive profiteering resulted from the shortage of imported goods. In Port Royal, Virginia, one Robert Johnston, newly moved from Philadelphia, had been retailing nails at higher prices than the local merchants. Accordingly he was approached by

⁶¹Purdie, Virginia Gazette (Williamsburg), 29 March 1776, 1, col. 1.

⁶²William Pitt, cited by Lorenzo Sabine, Biographical Sketch of the Loyalists of the American Revolution (Boston: 1864), I, 62.

⁶³Dixon and Hunter, Virginia Gazette (Williamsburg), 4 February 1775, 3, col. 3.

the Committee and reprimanded, after which he voluntarily signed
⁶⁴
 the Association.

Not everyone, however, approached the Revolution with altruistic motives. Robert Shedden of Portsmouth saw only quick profits. In a letter to John Shedden of Glasgow in November 1775, after expressing the overwhelming Tory leanings of Norfolk and Princess Anne Counties, he wrote of the great need for dry goods:

Depend on it, you will never have such another opportunity to make money by dry goods in this country. Osnabruks, canvas &c. and every necessary article, a large and full assortment of goods, nails, &c. bring as many as you can get credit for.⁶⁵

The letter gives no indication as to how the goods were to be brought in to get around the nonimportation agreement. With so many navigable rivers, the obvious answer was smuggling, and this certainly was resorted to on occasion. A letter from Glasgow, of which an extract was printed in the Virginia Gazette, warns of just such activities:

The Molly, Capt. Mitcheson of Whitehaven, belonging to Chambers and company, has taken a large cargo on board, and cleared out for Quebec. The Cargo consists of goods only fit for the Virginia market, viz. 800 pieces of cotton, large quantities of nails, hose, Irish linen, and saddlery. It is believed these goods are intended to be smuggled on the coast of Virginia, but it is in the interest of the fair trader to prevent such practices. You will act as you think proper.⁶⁶

⁶⁴Purdie, Virginia Gazette (Williamsburg), 21 April 1775, (supplement), 4, col. 3.

⁶⁵Robert Shedden to John Shedden, 20 November 1775, quoted in Purdie, Virginia Gazette (Williamsburg), 10 June 1775, 3, col. 1.

⁶⁶Dixon and Hunter, Virginia Gazette (Williamsburg), 10 June 1775, 3, col. 1.

The real American intention was to deny support to British manufacturers in hopes they would exert pressure on the British administration to correct American grievances. The Americans had no objections to constructing their buildings with British nails. So, when hostilities commenced, the Americans resorted to privateering. New England, as the predominant shipping region of the colonies, was most active, and the Virginia Gazette eagerly reported its prizes, such as a Newburyport privateer's capture of a Quebec-bound ship with 267 casks of nails and twenty-two and one-half barrels of gunpowder.⁶⁷

Virginia, however, resorted to other sources. Many nails, as mentioned previously, were imported from the Continent via the West Indies. Many Virginia Gazette advertisers of the late 1770's noted that their nails came from such points as Holland, Nantes, the West Indies, Martinique, St. Croix, and France. One Virginian even proposed that France be compensated for intervening on America's behalf by granting them the privilege of trading with us,⁶⁸ but the French undoubtedly realized they could gain the trade without the commitment even though their military assistance was later of great importance.

The British Navy, however, did not sit idly by while France and Holland reaped the benefits of the trade with her former colonies. A blockade was imposed, and blockade running became about

⁶⁷Purdie, Virginia Gazette (Williamsburg), 22 November 1776, 2, col. 1.

⁶⁸Ibid., 29 March 1776, 2, col. 3.

the only method for goods to reach Virginia. The odds were great in this game of cat and mouse, particularly when the cat had the largest navy in the world. Consequently, some masters fared better in getting their wares through than others. The fate of some of the less fortunate appeared in announcements in the Virginia Gazette throughout the period. Nails and other cargo from the brigantine Dispatch, ". . .lately chased on shore and stranded on the coast of North Carolina. . ." were to be sold at Petersburg.⁶⁹ The cargo of the snow Mars, including French nails, was to be sold by Doener and Marck for the insurers. The Mars had been run ashore eight miles south of Cape Henry in Princess Anne County.⁷⁰

This might seem to indicate that under the pressure of war, Virginians merely shifted the source of their imports to meet their demand for nails. However, the early resolutions to establish and encourage domestic production were not empty promises. Advertisements for nailers from areas as widely separated as Alexandria and Portsmouth appeared for the first time. The Shenandoah Valley was the great center of the iron industry. Most of the forges were located there because of the proximity to furnaces.⁷¹ It was to here also, in

⁶⁹Dixon and Nicolson, Virginia Gazette (Williamsburg), 2 October 1779, 3, col. 1.

⁷⁰Purdie, Virginia Gazette (Williamsburg), 19 June 1778, 3, col. 1.

⁷¹Emory Q. Hawk, Economic History of the South (New York: 1934), 302.

Augusta County, that William Freal moved from Pennsylvania and established one of the oldest nail factories in the country. This factory was said to be in operation as early as 1777.⁷²

Wanted at Hunter's iron works, to whom suitable encouragement will be given, a masterly hand in a wire mill; also nailers. . .⁷³

This advertisement which appeared in the Virginia Gazette in December 1779, shows that nails were being produced at one of America's largest ironworks at the time. Hunter's works, which were located on the Rappahannock River slightly more than two miles above Fredericksburg, were described by Ebenezer Hazard in 1777:⁷⁴

The operation was so extensive as to actually resemble a small village, Hazard noted. There were houses for the workmen, a grist mill, saw mill, cooper's shop, saddler's shop, brass founder's shop, wheelwright's shop, steel works, and of course a large blacksmith shop. A slitting and planing mill and furnace were under construction, and a steel works was nearby. A three-quarter mile canal supplied the necessary water power. Nails and nail rod, after the slitting mill had been completed, were among the most important products of the works.

Virginia did not depend solely on private enterprise to supply nails to the Commonwealth. Under the sponsorship of the War Office, Virginia actively engaged in promoting industry by having

⁷²Kathleen Bruce, Virginia Iron Manufacture in the Slave Era (New York: 1931), 22.

⁷³Dixon and Nicolson, Virginia Gazette (Williamsburg), 4 December 1779, 2, col. 2.

⁷⁴"The Journal of Ebenezer Hazard in Virginia, 1777," Virginia Magazine, LXII, No. 4 (1954), 417.

James Anderson, a Williamsburg blacksmith, operate a nail factory for the Commonwealth. Anderson's greatest problem seemed to be getting enough qualified workers to keep up with the business which poured into his shop:

I will pay extraordinary wages to a good BLACKSMITH and NAILER that is capable of acting as foreman in my shops.

75

- James Anderson -

Great wages will be given by the subscriber to journeyman Gunsmiths, Blacksmiths, and Nailors, that are good workmen. None others need apply. Six or eight boys are wanted as apprentices.

76

- James Anderson -

Colonel Muter of the War Office was most enthusiastic about the venture. When the contract with Anderson expired in 1780, Muter urged that it be renewed because of the demand for nails at that time, which had every prospect of continuing. Such projects as the Point of Fork Arsenal absorbed large quantities of nails. The arrangement was that the bill for the victuals and clothes for Anderson's nine lads engaged in making nails was paid by the Commonwealth.

77

⁷⁵Dixon and Nicolson, Virginia Gazette (Williamsburg), 16 April 1779, 2, col. 2.

⁷⁶Purdie, Virginia Gazette (Williamsburg), 3 October 1777, 2, col. 2.

⁷⁷Calendar of Virginia State Papers and Other Manuscripts, ed. William Palmer et. al. (Richmond, Virginia: 1875), I, 402.

Nail rod was supplied from Fredericksburg, in all probability the product of Hunter's Iron Works. Early in 1781 Anderson held out for better contract terms, so the state entered into direct negotiation with the nailers in order to keep supplying that necessary article. Their terms seem strikingly contemporary: "The tradesmen are willing to work for the State, provided they are protected from militia duty and drafts," as well as being assured of an adequate supply of provisions.⁷⁸ Eventually, however, a new contract was signed with Anderson.

Later in 1781, Colonel William Davies, Colonel Muter's successor, was corresponding with Anderson concerning the possible creation of a Corps of Artificers in the state militia. As proposed, Anderson would have held the rank of Captain, there would be four subordinate officers, twelve gunsmiths, six gunstockers, twenty-four blacksmiths, one striker (heavy hammerer), seven nailers, twelve carpenters, twelve saddlers and harnessmakers, ten wheelmakers, twenty-four shoemakers, and twenty-four tailors.⁷⁹ The envisioned Corps of Artificers would have greatly expanded the role of the state in basic industries, but no action appears to have been taken before the end of the war caused all plans to be dropped.

At any rate, Anderson was again contracted to manage the public shops in 1782, but by that time there were difficulties in

⁷⁸Ibid., I, 473.

⁷⁹Ibid., II, 304.

securing nail rod which nearly stopped production. Davies reported to Governor Harrison that "Mr. Anderson is exceeding uneasy at not being able to be of use, either to the public or himself, in his department."⁸⁰ Later that year Anderson retired from public service and moved back to Williamsburg from Richmond, where he continued his blacksmithing business until his death.

⁸⁰Ibid., III, 206.

to ending

CHAPTER IV

THE POST-WAR DECADES AND THE BEGINNINGS OF MECHANIZATION

The frustration Anderson felt was the result of the general failure of many of the larger industrial ventures during the post-war period. As long as the war was in progress, these industries were kept in operation, but when war associated orders disappeared or alternate sources of supply again became available, many works closed, Hunter's among them.

The Virginia nail making industry did not disappear after the war, but Britain again captured the lion's share of the market. Nail rod often had to be imported from as far away as Philadelphia, and it was difficult to obtain and retain nailers. British nails were cheap and could be obtained with little effort. In the year ending September 30, 1790, Virginia imported 913,001.5 pounds of nails and spikes, almost entirely from England.

It was during this same period, however, that the nail making industry itself was undergoing profound changes. The age old method of laboriously shaping each nail from nail rod was both tedious and time consuming. Few really significant changes had been made in the process since Roman times. The late eighteenth century was the dawning of the industrial age, and on both sides of the

⁸¹Arthur G. Peterson, "Commerce of Virginia, 1789-1791," William and Mary Quarterly, Series II, X, No. 4 (1930), 303.

Atlantic men sought and first developed mechanical means to produce nails during this period.

The first advance came from Cumberland, Rhode Island, where Jeremiah Wilkinson developed a method of cutting tacks from sheet metal plates about 1775.⁸² The process could not be applied immediately because the plates required to make nails were much thicker than the thin sheets required for tacks. The invention of a machine for cutting nails from plates is credited to another New Englander, Ezekiel Reed (Rud) of Bridgewater, Massachusetts, in 1786. Two years later he got a patent for cutting and heading nails in one operation, although like most early mechanical headers, it was not particularly successful.⁸³ Early cut nails continued to be headed by hand for many years.

In 1790 Jacob Perkins of Newburyport, Massachusetts, developed what was to prove a more successful design of machinery to cut nails from iron plates. Five years later he patented another machine which would cut and head nails in one operation.⁸⁴ Later that year J. G. Pierson of New York invented another nail making machine. In all, eleven patents were registered during the decade of 1795-1806 for nail, tack, and brad making machines.⁸⁵

⁸²Bishop, American Manufactures, I, 388.

⁸³Weiss and Weiss, Forgotten Mills, 67.

⁸⁴Bishop, American Manufactures, I, 492.

⁸⁵Weiss and Weiss, Forgotten Mills, 69.

The first mass production nail factory in the country was opened in Amesbury, Massachusetts, in 1798. It was incorporated in 1805 with a capital of \$450,000. By 1810 there were 410 nail factories producing 15,000,000 nails annually in the country.⁸⁶ As early as 1791 Hamilton had written that private enterprise fostered by protective state duties had already brought prosperity to some industries, among them nail making.⁸⁷ In 1789, the new Federal Government had placed a one cent per pound duty on all imported nails and spikes, over the objections of the South which had few naileries at that time. Significantly, tacks and brads were duty free, for it was acknowledged that the British could produce superior goods more cheaply in the smaller sizes.

The British were mechanizing their industry at about the same time. Thomas Clifford developed a method of forming nails in a groove between rollers in 1790. The nails emerged with heads and tails joined, and had to be separated later. This advance was quickly followed by nearly forty other patents in the next few years. America, however, still retained credit for the first machine to cut and head nails in one operation.

The cut nails produced by the new machines actually had several advantages over the older wrought nails, for they could be

⁸⁶Weiss and Weiss, Forgotten Mills, 69.

⁸⁷Alexander Hamilton, Report on Manufactures (December, 1791), cited by John C. Miller, The Federalist Era (New York: 1960), 63.

driven into more solid timber without drilling, were less liable to split the board, had better holding qualities, required no flattening of the head, and most significantly, sold for less per pound and numbered more per pound than wrought nails. Thus the new cut nails almost universally superceded wrought nails as soon as they reached the market, usually about 1800,⁸⁸ Wrought nails continued to be produced for special applications, especially where clinching the nail was necessary, for cut nails were quite brittle and could not be bent over without breaking.

The operation of the early cutting machines was actually quite simple. Nail plates about a foot long and with width to suit the size of nail being made would be heated to a deep red, then held with a wooden handle with a clamp at one end. A double crankshaft with a band wheel at one end and flywheel at the other powered the heavy wrought iron cutter blade which rose and fell in a heavy frame. At each stroke a tapering strip was cut from the plate to form a nail. Then the operator turned the plate over to obtain a uniform taper on the nails. Larger sizes were slower to produce--8d. nails could be cut at eight times the speed of 20d. nails.⁸⁹ Earlier machines for smaller sized nails were foot powered, but by the early nineteenth century most were belt driven.

⁸⁸Henry C. Mercer, "The Dating of Old Houses," A Collection of Papers Read Before the Bucks County Historical Society (1926), V, 537.

⁸⁹Weiss and Weiss, Forgotten Mills, 74-75.

FIGURE III
EARLY NAIL CUTTING MACHINERY

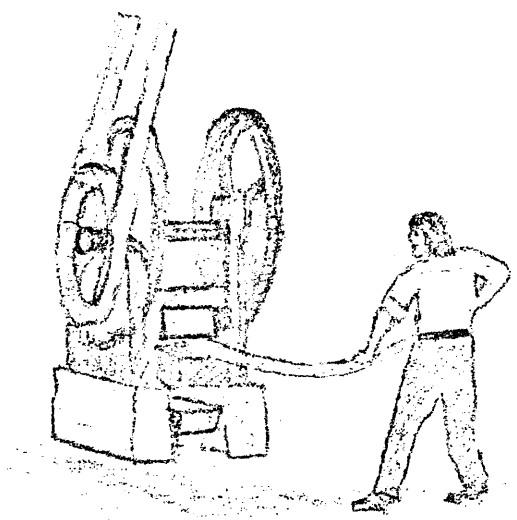

Cutting nail plates

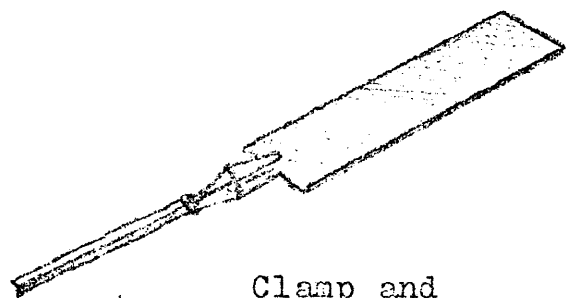

Clamp and
nail plate

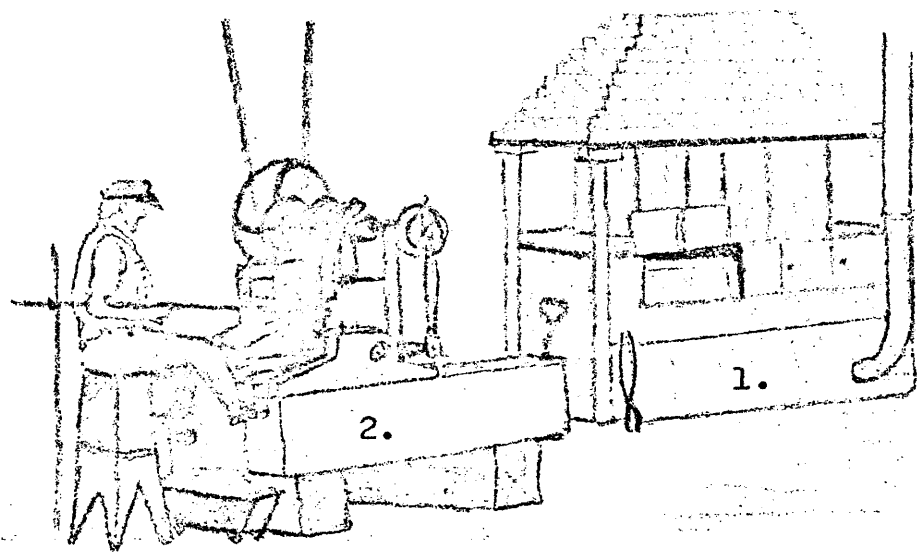

Furnace for heating plates (1.) and nail cutting machine (2.).
The machine illustrated here also headed nails.

Adapted from: J. R. Chapin,
"Among the Nail Makers,"
Harpers, XXI (1860), 161-62.

Fortunately, very complete records exist for one of Virginia's first mass production naileries, that of Thomas Jefferson at Monticello. Jefferson's nailery was only one of several operations which he developed along Mulberry Row at Monticello, including spinning, weaving, and blacksmithing. The operation was begun in April 1794, when forty bundles of nail rod arrived. For labor he used slave boys aged ten to sixteen (the girls were employed in spinning). Apparently, however, he experienced some difficulty taming their youthful spirits, for at one point he resolved to make Cary, possibly a runaway, an example to the others " . . . in order to maintain the police so rigorously necessary among the nail boys."⁹⁰

Jefferson threw himself enthusiastically into the new activity. He wrote Henry Knox in 1795 that what time he did not spend on his farming was spent on his nailery, so that he rarely had time to read or write.⁹¹ It was with obvious pride, however, that he undertook this activity, as reflected in one of his letters: "I am myself a nail-maker . . . my new trade of nail-making is to me in this country what an additional title of nobility or the ensigns of a new order are in Europe."⁹²

Originally only wrought iron nails were produced, but on 22 February 1796 a new nail making machine from England was introduced.

⁹⁰Edwin M. Betts, ed., Thomas Jefferson's Farm Book (Princeton, New Jersey: 1953), 19.

⁹¹Thomas Jefferson to Henry Knox, 1 June 1795, Henry Knox Papers (Boston: 1960), XXXVII, 107 (microfilm).

⁹²Betts, Farm Book, 426.

It differed from most American machines in that it still used nail rods rather than plates. Rods were heated to a black heat, then inserted in the machine, which cut off blanks of the required length, which were then struck by a moving die to form a head. It is not clear if the pointing was accomplished in the cutting operation, or had to be done by hand.

Nail rod had to be imported from Philadelphia, since after Hunter's Works had closed there were no slitting mills in Virginia. Jefferson's operation was carried out in combination with his blacksmithing in a wooden shop eighteen by thirty-seven feet. An addition was planned in 1796, but it is unknown if this was completed. At any rate a new nailery of stone was built in 1801.

He began by using only one fire, but by 1796 was using three fires and producing 10,000 or more nails per day.

At first, fearing the wrath of the importing houses, merchants refused to take his nails, but Jefferson realized the inexorable laws of economics were on his side. Early in 1796 he wrote Archibald Stuart that

. . .it is tolerably certain that the moment my deposit opens there will be an entire stoppage to the sale of all imported nails, for nobody can retail them in the upper country at Richmond wholesale prices, advanced only 5. or 10. percent. (for commission and transportation).⁹³

Not long after he wrote:

I retail at 5. per cent on the Richmond wholesale prices. This I presume will soon give me a clear field, and defeat in this particular this effort of the general system of Scotch

⁹³Ibid., 432.

FIGURE IV

JEFFERSON'S NAILERY AT MONTICELLO

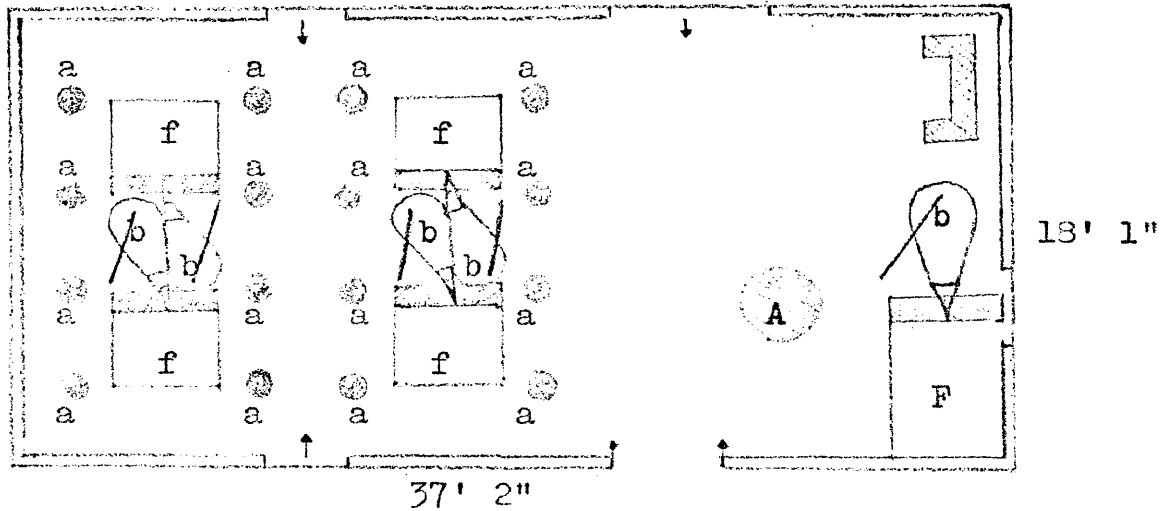

- a Nailer's anvils
- A Blacksmith's anvil
- b Bellows
- f Nailer's forges
- F Blacksmith's forge

Adapted from Jefferson's plan for his original (1794-1801) nailery on Mulberry Row, reproduced in Edwin M. Betts, ed., Thomas Jefferson's Farm Book (Princeton, N.J.: 1953), following p. 56.

94

policy to suppress every attempt at domestic manufacture.

When Jefferson was at home to manage the nailery it was quite successful. As early as 1795 he wrote, "The best resource of quarterly payment in my power is nails, of which I make enough every fortnight to pay a quarter's bill (for groceries, \$100-\$125)".⁹⁵ However, he soon found that he had to be more strict about the credit terms he gave. In July 1796, he wrote to William Alexander, an Augusta merchant, that the large and constant remittances of cash he was obliged to make in Philadelphia for nail rod constrained him to expect short payments for the nails he furnished. Thus he had lately found it necessary to require ready money instead of the three months credit he formerly gave, and asked that Alexander pay the L 16 10s. 3d. bill he owed for nails⁹⁶ delivered the previous September.

Although Jefferson's unavoidable absences from Monticello, especially during his terms as President and Vice President, complicated the problems of running the nailery, he still took a direct interest, writing to Howell and Jones, suppliers of nail rod in Philadelphia, and his overseer, Gabriel Lilly, concerning the nailery. He sought to make improvements when possible, such as writing Benjamin Perkins in an attempt to secure a set of drawings of his brother's nail making machine.

⁹⁴Ibid., 433.

⁹⁵Ibid., 429.

⁹⁶Ibid., 434.

The most serious problem caused by his absences was that although production continued, no one collected debts while Jefferson was away. This caused acute shortages of income, and attempts at collection immediately upon his return more often met with evasion than success. Nevertheless, the nailery was in continuous operation through 1812. It then had to be closed for the next three years because of the war; nail rod could not be shipped from Philadelphia. During the period from 1815 to 1823 it operated only intermittently.

During the height of its operation, Jefferson's nailery supplied much of the Piedmont area near Charlottesville and most of the Valley with nails. It was his practice to grant a monopoly on the distribution of his nails to but one retailer in each town. In addition he supplied individuals on occasion. For example, Monroe purchased the nails to construct Ash Lawn from his close friend's nailery.⁹⁷

In short, Jefferson's venture was one of the most promising attempts to establish the nail industry on a sound basis in Virginia. The demand was large, and the product of good quality. It failed principally because of mismanagement. Jefferson's governmental responsibilities kept him away from Monticello for so much of the time that he was not able to give his nailery the degree of attention

⁹⁷Hamilton W. Pierson, Jefferson at Monticello, ed. by James A. Bear, Jr. (Charlottesville, Virginia: 1967), 64.

it required. Had Jefferson been able to continue to devote the time to it he spent in the first years of operation, the outcome might have been entirely different.

Jefferson was not the only Virginia nailor of the period, however, for in Richmond he had at least two competitors, of whom unfortunately little is known. In the closing years of the century, the state undertook the construction of a "Penitentiary House" at Richmond under the direction of the architect Benjamin Henry Latrobe, which, of course, required nails. Robert Paul, who operated a nail factory in the city, offered to supply the state with nails "of the best quality" in 1797 for one shilling per pound.⁹⁸ Apparently the offer was accepted, for about a year later Latrobe reported to the Governor that "Mr. Paul is a very good nailer."⁹⁹

Thomas and William Callis were apparently among Paul's competitors, for in May 1799 they wrote the Governor that they would execute the grates for the penitentiary at 4d. per pound if the state would furnish the coal, iron, and tools, and that they would furnish the nails at 10-1/2d. per pound and provide the iron.¹⁰⁰

After the penitentiary was completed, the state once again got into the nail making business. Unwilling to receive no compensation at all for maintaining the inmates, and willing to test Jefferson's

⁹⁸Calendar of State Papers, VIII, 450.

⁹⁹Ibid., VIII, 513.

¹⁰⁰Ibid., IX, 22.

enlightened ideas on peneology, which involved both solitary confinement and work in common, the state sought to have prisoners produce some goods which would be saleable. Nail making was one of the activities chosen. The use of convicts as nailors, was not, however, an innovation, for a 1774 issue of the Virginia Gazette had offered a ten dollar reward for the return of Daniel Dunn, a convict servant and nailor¹⁰¹ by trade. It was Latrobe who urged that a nail cutting machine be installed in a letter to the Governor in 1798: ". . . I have drawings of all the Philadelphia Machines for making nails. We ought to think of making some, I am willing to take any trouble and give any assistance."¹⁰²

Apparently the instruction program was well underway in July of 1800, for Martin Mims, Keeper of the Penitentiary, reported that he had employed George Anderson Stile at \$36.00 per month to instruct¹⁰³ and work with the prisoners in nail making. In 1806 it was reported by a committee appointed by the Governor to inspect the penitentiary that thirteen hands were normally engaged in the manufacture of cut nails, most in heading the nails.¹⁰⁴

Despite the sporadic attempts to get the nail industry started in Virginia in the late eighteenth century, by the mid-nineteenth

¹⁰¹Purdie and Dixon, Virginia Gazette (Williamsburg), 10 November 1774, 4, col. 3.

¹⁰²Calendar of State Papers, VIII, 498-99.

¹⁰³Ibid., IX, 120.

¹⁰⁴Ibid., IX, 479.

century it was well established. Wheeling, then in Virginia, had a nail factory in 1811 and in time became one of the four or five largest centers of commercial nail manufacture in the country.¹⁰⁵ The Tredegar Iron Works in Richmond also became large producers. The Belle Island Works which became the Old Dominion Nail Works in 1856 had forty-eight machines in operation, and produced over 1,000 tons of nails annually.¹⁰⁶ The Old Dominion Nail and Iron Works, established at Lynchburg in 1884, expanded its plant and added a blast furnace just three years later.¹⁰⁷

The history of the nail making industry in early Virginia is a surprising one in that it developed so slowly and haltingly. Nail making operations had begun early as 1635 on the Eastern Shore, yet throughout the remainder of the seventeenth and early eighteenth century, very few nails seem to have been produced even by local blacksmiths. Similarly, the household industry of nail making by individual families, as it was practiced throughout the Northeast, appears to have been minimal, if existent at all. Virginia relied on England chiefly, and on her sister colonies, principally Massachusetts and Pennsylvania, for nails.

¹⁰⁵Clark, History of Manufactures, I, 516.

¹⁰⁶Bruce, Virginia Iron Manufacture, 293.

¹⁰⁷W. Ashbury Christian, Lynchburg and Its People (Lynchburg, Virginia: 1900), 349.

It was the onset of the Revolution that first shocked many Virginians with the realization that by depending on imports for almost all their nails, their supply of that vital commodity was very vulnerable. Blockade running with European nails from the West Indies proved a somewhat less than satisfactory method of supply.

Unfortunately, Virginia's response to the critical shortage of nails was mostly in the form of stopgap measures rather than an attempt to establish the industry as a permanent part of the state's economy. James Anderson's nail factory in Williamsburg reflects well this haphazard operation. At any rate, at the close of the Revolution England and Scotland again became Virginia's chief suppliers, and their hold over the market can be seen in Jefferson's bitter denunciation of the ". . . Scotch policy to suppress every attempt at domestic manufacture!"

The real precursors of Virginia's nineteenth-century nail making industry were operations such as Jefferson's nailery at Monticello and the nailery at the Richmond penitentiary. Both of these operations were progressive, incorporating the latest machinery in an attempt to mass produce nails for the domestic market. These were probably the first shops devoted exclusively to nail production, rather than operations turning out nails as a sideline. Their success proved that Virginia naileries could compete favorably with foreign producers, and that such operations, if well managed, could be profitable.

¹⁰⁸ Betts, Farm Book, 433.

This was a fundamental step which had to be passed before large nail factories, such as had already sprung up in Massachusetts and Pennsylvania, would be built. Perhaps Jefferson's assessment of the Virginians' distinct preference for the agrarian way of life in his Notes on the State Of Virginia was not far from the mark. In any event, for this and other reasons, the nail making industry in Virginia took nearly two centuries to develop solid roots, but once established formed the basis of an important industry in the nineteenth century.

APPENDIX I

A GLOSSARY OF EIGHTEENTH-CENTURY NAIL TYPES AND SIZES

1. Back and Bottom Nails

- a) made with flat shanks to hold fast and not open the wood. ¹
- b) for any liquid vessel made of planks or boards. ²

2. Boat Nails - see Clench Nails

3. Brads

- a) a sort of nail, slender and without heads. ²
 - i) Joiners (or Joyners) Brads - plain, for hardwood wainscot.
 - ii) Batten Brads - for soft wood - wainscot.
 - iii) Flooring Brads - plain, for softwood joists.
 - iv) Flooring Brads, Strong - fit for hard joists.
 - v) Quarter-heads - for soft wood.
 - vi) Quarter-heads, Strong - for hardwood joists.
 - vii) Bill-brads - Quarter-heads.

Sizes:

Size	2d.	3d.	4d.	6d.	10d.	20d.	24d.
Length	1"	1 1/2"	2"	2 1/4"	2 1/2"	2 7/8"-3 1/2"	---

4. Bullein Nails

- a) with round heads but short shanks, tinned and lacquered, used in hanging of rooms, fitting of beds, and covering of stools, chairs, coffins etc. ²

Cast Nails

- a) nails made in a mold from cast iron, in various sizes.

5. Clamp Nails

- 1
- a) for fastening the clamps in building etc.
e.g. for fastening the panels of a door to the
clamp rails etc.

6. Clasp Nails (Brads)

- a) whose heads, clasping and sticking into the wood, render
the work smooth, so as to admit a plane over it.¹
- b) Long Nails - proper for any fine building in fir or
soft woods.²
- 2
- c) Strong Nails - fit for oak and other hard woods.

Sizes:

Long Nails- 7, 7 1/2, 8, 10, 13, 14, 15, 18, 21, 22,
23, 28, 32, 36 and 40 lb./thousand.

Strong Nails- 15, 18, 28, 32, 40 lb./thousand.

7. Cleat Nails

- a) used to attach cleats or similar hardware.

8. Clench Nails (or Boat Nails)

- a) used by boat and barge builders, and proper for any
boarded buildings that are to be taken down because
they will drive without splitting the wood and draw
without breaking; of these there are many sorts.¹

9. Clout Nails

- 1
- a) for nailing on clouts to axle trees.
- 2
- b) proper for fastening any iron to wood.

Sizes: 4 1/2, 7, 8, 9, 12, 15, 16 lb./thousand.

10. Deck Nails

- a) for fastening of decks in ships, doubling of shipping and
floors laid with planks.¹
- 2
- b) Dye-headed deck nails. 2
Clasp-headed deck nails.

Sizes: 4, 4 1/2, 5, 5 1/4, 6, 6 1/2, 7, 8, 9" long.

11. Dog Nails

- a) for fastening of hinges on doors, etc.¹

Sizes: 2 & 3 lb./thousand

12. Double Garron Nail

- a) a spike, about six inches long, used in rough framing, as in a roof.³

13. Flat Points

- a) Long - much used in shipping, and are proper where there is occasion to draw and hold fast, and no convenience of clenching.¹
- b) Short - these are fortified with points to drive into oak or other hard wood.²

Sizes:

Long: 7 1/2, 8, 9, 10, 11, 12, 13, 14, 16, 18, 21, 22, 23, 26, 40, 55, 75, 110 lb./thousand.

Short: 5, 9, 18, 26, 32, 40, 55, 75, 110 lb./1000.

14. Frost Nails

See Horseshoe Nails.

15. Framing Nails

- a) large nails used in the framing of buildings.

16. Hob Nails

- a) for studding the heels and soles of shoes. Hobnails are short, sharply pointed, and large headed.⁴

17. Hold Fast

- a) a sort of wrought iron spike used by carpenters for rough work where the stuff is not framed, and by joiners for securing ordinary shelves etc. to walls, or other hold. It is made with a shoulder, by which it is driven into the wall with a hammer and a round flat head in which there is a hole for a clout or dog nail to secure the wood or other work.³

Sizes: 4d. (3") 6d. (9").

18. Horseshoe Nails

- a) for fastening horseshoes to horses hoofs - a sharply pointed tapering nail with large head.⁴ They come in two forms, common with flat heads and frost nails with pointed heads.

19. Jobent Nails (Dog Nails)

- a) for nailing thin plates of iron to wood, as small hinges on cupboard doors.¹

Sizes: 2 & 3 lb./thousand

20. L-Heads

- a) nails with heads on one side of the shank only, resembling an inverted L, used principally as flooring and trim nails.

21. Lath Nails

- a) nails used by the plasterer, pointed with flat heads, about 3/4" long.³

22. Lead Nails

- a) for nailing lead, leather, and canvas to hard wood.¹

Sizes: 4 1/4, 7, 8 lb./thousand.

23. Peg

- a) a small pointed piece of wood for several uses, also a wooden pin, turned with a kind of round head, for hanging up hats, clothes, etc.²

24. Pin

- a) a slender, sharp piece of wood for pinning or fastening together battens tenoned and mortised, in wainscoting etc.²

25. Port Nails

- a) for nailing hinges to the ports of ships.¹

Sizes: 2 1/2, 3, 4, 5" long.

26. Pound Nails

- a) four-square nails used for little except paleing (fencing).

Sizes: 6d. 8d. 10d. 20d. 40d.

FIGURE V
ASSORTED HAND WROUGHT NAILS
from
Eighteenth-Century Virginia Buildings

1. Spikes.
2. Framing Nails.
3. Streak Nail.
4. Rose Head Nails.
5. Rose Head Sheathing Nails.
6. T-Head Nail.
7. Quarter-Head Flooring Brad.
8. Flooring Brads.
9. Shingle Nail.
10. Round Head Nail.
11. Lath Nail.
12. Upholstery Tacks.
13. L-Head Trim Brad.
14. L-Head Flooring Nail.

Nails from Paul Buchanan Collection, Colonial Williamsburg Department
of Architectural Research.

Grid Scale: One Inch Squares.

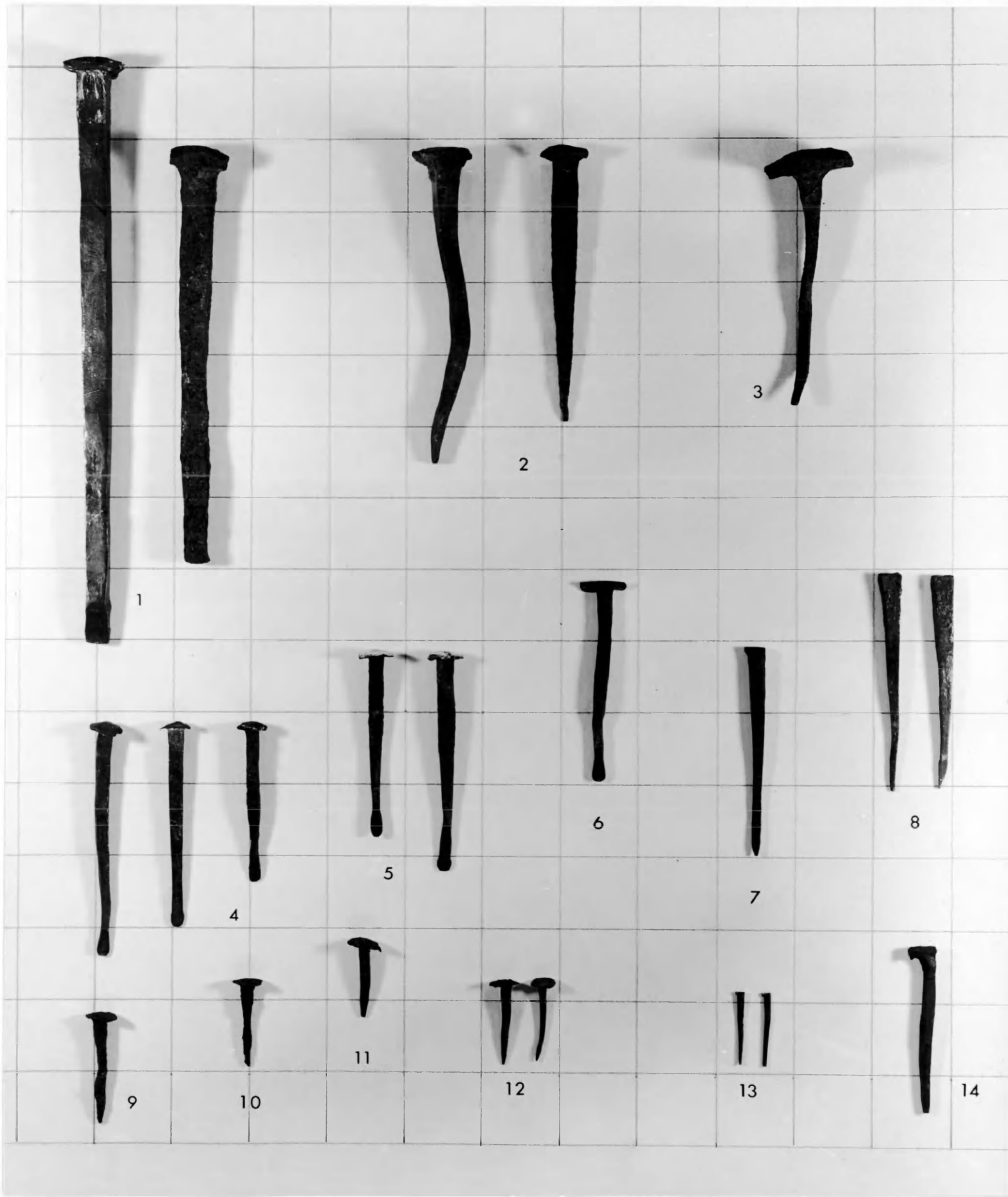

27. Pump Nails

- a) see Tacks, definition b.

28. Quarter Head

- a) nails with heads offset on one side of shank only, see Brads.

29. Ribbing Nails

- a) principally used in shipbuilding, for fastening the ribs of ships in their places.¹

Sizes: 5, 5 1/2, 6, 6 1/2, 7, 7 1/2, 8, 8 1/2, 9" long.

30. Roofer's Nails

- a) similar to lath nails, used to attach roofing materials, including slate.

31. Rose Nails (Rose Heads)

- a) which are drawn four-square in the shank. In some countries all the larger nails are of this sort. The common 2d. nail.¹ The heads of rose nails are formed into four or more facets.

Sizes: 1 3/4, 2, 2 1/2, 2 3/4, 3, 3 1/2, 3 3/4, 4, 4 1/4, 4 3/4, 5, 9, 10, 13, 14, 16, 17, 18, 24, 26, 28, 30, 32, 36, 40 lb./thousand.

32. Rother Nails

- a) these are used principally to fasten rother irons to ships.²

33. Round Head Nails

- a) for fastening on hinges; for any other use where a neat head is required.¹

Sizes: 2d. 3d. 4d. 5d. 6d. 8d.

34. Saddler's Nails

- a) similar to shoemaker's nails, but smaller.

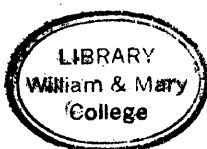

35. Scuffer Nails (Scupper Nails)

- a) which have a broad head, and are used for fastening leather and canvas to wood.¹

Sizes: 4 1/4, 7, 8 lb./thousand.

36. Sharp Nails

- a) used especially in the West Indies. Made with sharp points and flat shanks, it is a very proper nail for ordinary uses, where soft wood is used.²

Sizes: 2 1/2, 2 3/4, 3, 3 1/2, 4, 4 1/2, 5, 5 1/2, 6, 6 1/2, 7 1/2, 8, 9, 10, 11, 12, 13, 14, 15, 18, 19, 20, 21, 22, 23, 28, 32, 26, 40 lb./thousand.

37. Sheathing Nails

- a) for fastening on sheathing.¹
- b) for fastening sheathing boards to ships, the nail full three times as big as the board is thick.²

Sizes: 1 1/4, 1 1/2, 1 3/4, 2, 2 1/4, 2 1/2, 2 3/4, 3, 3 1/4, 3 1/2" long.

38. Shingle Nails

- a) large headed nails used to fasten shingles to roofs.

39. Shoemaker's Nails

- a) used to bind the thick soles of shoes, including hob nails.

40. Slate Nails

See Roofers Nails.

41. Spikes

- a) large long iron nails, with great flat heads, used to fasten planks or timber.²

42. Sprigs

- a) small flat nails of various sizes usually having the head

returned on one side, which gives a double thickness for receiving the blow of the hammer and clenching the wood. Also short square nails with a square head, the top being raised to a point or diamond shaped.³

- b) L-Head nails in general.

43. Square Nails

- a) same shape as sharp nails, used for oak and hard woods. The points are stronger than sharp nails.²

Sizes: 2 1/2, 2 3/4, 3, 4, 4 1/2, 5, 5 1/2, 6, 6 1/2, 7, 8, 9, 10, 11, 12, 13, 14, 15, 16, 18, 19, 20, 22, 23, 24, 28, 30, 32, 36, 40, 55, 75 lb./thousand.

44. Staple

- a) a piece of iron formed into the shape] and driven into the frame of a door, used to catch the bolt or hasp of a lock.³

45. Streak Nails (Tire Nails)

- a) used to fasten the streak or iron rim to spoked wooden wheels, as on gun carriage wheels.⁵

46. T-Head Nails

- a) nails with heads extending on two sides of the shank only, or rose heads which have been flattened on two sides of the shank, so the head will clench the wood.

47. Tacks

- a) the smallest serve to fasten paper to wood, etc.,¹
 b) the midding for wool cards and oars, the larger for upholsterers and pumps.²

Sizes: 2 1/4, 5, 6, 8, 9, 14, 15, oz./thousand.

48. Tenter Hook

- a) a small nail formed of an angle or L shape, both ends pointed, one for being driven into wood, and the other for receiving cloth or other material, as in drying.³

49. Tire Nails (Streak Nails)

- a) for fastening iron tires to wooden wheel rims.

50. Tree Nails

- a) a wooden pin, usually hardwood, used to pin mortise and tenon joints in framing members.³

FOOTNOTES

1. Builder's Magazine (1774), I.
2. Richard Neve, The City and Country Purchaser's and Builder's Guide, 3rd. ed. (London: 1736).
3. Architectural Publications Society, The Dictionary of Architecture (London: 1853-92).
4. Harry B. and Grace M. Weiss, Forgotten Mills of Early New Jersey (Trenton, New Jersey: 1960).
5. John Miller, A Treatise of Artillery (London: 1780).

APPENDIX II

A NOTE ON NAIL CLASSIFICATION

As one might well gather from studying the previous Glossary of Eighteenth-Century Nail Types and Sizes, there was no single standard of classification in that century. The problem of nail nomenclature can be traced back to the English medieval period, during which there was a bewildering array of names for the same type of nail on one hand, while the same name in another case might apply to several widely varied types of nails. By the fifteenth century a general classification of nails by price per hundred as well as by usage was common. Hence nails which sold for 8d. per hundred were termed eight penny nails. One complication here is whether this meant exactly one hundred, or whether the long hundred (i.e. six score or 120 nails) was used. A further confusion resulted when prices became associated with nails of particular sizes, and then prices changed. For example, in 1471, 5d. nails cost 4d. per hundred.¹ Others, such as Weiss and Weiss, have suggested that the use of penny (d.) in nail sizing may be a corruption of pound and that a 10d. nail might signify that 1000 (or 1200) nails of that size weighed ten pounds.

In the eighteenth-century, then, there were five broad methods of classifying nails. The first was by usage, and was indicated by the name of the nail, for example clout nails and sheathing nails. The second was by shape, for example L-heads or square nails. The final three classifications deal with nail sizes. Classification by penny usually

ranged between 2d. and 40d. A more convenient measure was weight per thousand nails. These could range from 2 1/4 ounces to 110 pounds. For the ultimate in simplicity, one could simply classify the nail by its length in inches.

Even today the matter is not completely resolved, for though nails are usually purchased by the pound, they are still classified, depending on type, by both pennies and length.

¹ Louis Salzman, Building in England (Oxford: 1952), 315.

BIBLIOGRAPHY

I. Primary Sources:

- Betts, Edwin M., ed. Thomas Jefferson's Farm Book. Princeton, New Jersey: American Philosophical Society, 1953.
- Boyd, Julian P., ed. The Papers of Thomas Jefferson. Princeton, New Jersey: Princeton University Press, 1950-65.
- Campbell, R. The London Tradesman. London: T. Gardner, 1747.
- Diderot, Denis. Encyclopedie ou Dictionnaire Raisonne des Sciences, des Arts, et des Metiers. 17 v. + 11 v. plates + 2 v. index. Paris: 1753.
- Gillispie, Charles C. A Diderot Pictorial Encyclopedia of Trades and Industry. New York: Dover Publications, Inc., 1959.
- Hazard, Caroline, ed. Nailer Tom's Diary. Boston: The Merrymount Press, 1930.
- Jefferson, Thomas. Notes on the State of Virginia. ed. William Peden. Chapel Hill, North Carolina: University of North Carolina Press, 1955.
- Jones, Hugh. The Present State of Virginia. ed. Richard L. Morton. Chapel Hill, North Carolina: University of North Carolina Press, 1956.
- Mason, Frances N. ed. John Norton & Sons: Merchants of London and Virginia. Richmond, Virginia: The Dietz Press, 1937.
- Moxon, Joseph. Mechanick Exercises: or the Doctrine of Handy-Works. London: 1703.
- Muller, John. A Treatise of Artillery. London: 1780.
- Neve, Richard. The City and Country Purchaser's and Builder's Dictionary: or, The Complete Builder's Guide. 3rd. ed. London: 1736.

Pierson, Reverend Hamilton W. Jefferson at Monticello. ed. James A. Bear, Jr. Charlottesville, Virginia: University Press of Virginia, 1967.

II. Secondary Sources:

Ames, Susie M. Studies of the Virginia Eastern Shore in the Seventeenth Century. Richmond, Virginia: The Dietz Press, 1940.

Architectural Publications Society. The Dictionary of Architecture. 8v. + 3v. Illustrations. London: Architectural Publications Society, 1853-92.

Aston, James, and Story, Edward B. Wrought Iron. 2nd. ed. Pittsburgh: A. M. Beyers Co., 1939-41.

Bishop, J. Leander. A History of American Manufactures from 1608 to 1860. 3rd. ed. 3v. Philadelphia: Edward Young & Co., 1868.

Brown, Robert E. and B. Katherine. Virginia 1705-1786: Democracy of Aristocracy?. East Lansing, Michigan: Michigan State University Press, 1964.

Bruce, Kathleen. Virginia Iron Manufacture in the Slave Era. New York: The Century Co., 1931.

Bruce, Phillip A. Economic History of Virginia in the Seventeenth Century. 2v. New York: The Macmillan Co., 1907.

Bullock, Orin M., Jr. The Restoration Manual. Norwalk, Connecticut: Silvermine Publishers, Inc., 1966.

Christian, W. Asbury. Lynchburg and Its People. Lynchburg, Virginia: J. P. Bell Co., 1900.

Clark, Victor S. History of Manufactures in the United States. 1929 ed. New York: Peter Smith, 1949.

Cocke, William R. The Point of Fork Arsenal. Columbia, Virginia: 1946.

Dow, George F. The Arts and Crafts in New England, 1704-1775. Topsfield, Massachusetts: The Wayside Press, 1927.

Forbes, Allan, and Cadman, Paul F. France and New England. 4v. Boston: State Street Trust Co., 1925-29.

- Forman, H. Chandlee. Old Buildings, Gardens, and Furniture in Tidewater Maryland. Cambridge, Maryland: Tidewater Publishers, 1967.
- Forman, Henry Chandlee. Virginia Architecture in the Seventeenth Century. Williamsburg, Virginia: Virginia 350th Anniversary Celebration Corp., 1957.
- Hamlin, Talbot. Benjamin Henry Latrobe. New York: Oxford University Press, 1955.
- Hawk, Emory Q. Economic History of the South. New York: Prentice-Hall, 1934.
- Hawke, David. The Colonial Experience. Indianapolis: The Bobbs-Merrill Co., Inc., 1966.
- Hindle, Brooks. Technology in Early America. Chapel Hill, North Carolina: University of North Carolina Press, 1966.
- Hummel, Charles F. With Hammer in Hand. Charlottesville, Virginia: University of Virginia Press, 1968.
- Innocent, C. F. The Development of English Building Construction. Cambridge, England: Cambridge University Press, 1916.
- Mercer, Henry C. Ancient Carpenter's Tools. 3rd. ed. Doylestown, Pennsylvania: Bucks County Historical Society, 1960.
- Miller, John C. The Federalist Era, 1789-1801. New York: Harper Torchbooks, 1960.
- Morton, Louis. Robert Carter of Nomini Hall. Williamsburg, Virginia: Colonial Williamsburg, Inc., 1945.
- Morton, Richard L. Colonial Virginia. 2v. Chapel Hill, North Carolina: Virginia Historical Society, 1960.
- Nelson, Lee H. Nail Chronology as an Aid to Dating Old Buildings (Technical Leaflet 48, Revised). Nashville: American Association for State and Local History, 1968.
- Oliver, John W. History of American Technology. New York: The Ronald Press Co., 1956.
- Powys, A. R. Repair of Ancient Buildings. London: J. M. Dent & Sons, Ltd., 1929.
- Rose, Walter. The Village Carpenter. Cambridge, England: Cambridge University Press, 1952.

- Sabine, Lorenzo. Biographical Sketches of the Loyalists of the American Revolution. 2v. Boston: Little, Brown, & Co., 1864.
- Salzman, L. F. Building in England Down to 1540. Oxford: Clarendon Press, 1952.
- Shurtleff, Harold R. The Log Cabin Myth: A Study of the Early Dwellings of the English Colonists in North America. Cambridge, Massachusetts: Harvard University Press, 1939.
- Singer, Charles, et al. History of Technology. 5v. Oxford: Clarendon Press, 1954-58.
- Sloane, Eric. A Museum of Early American Tools. New York: Wilfred Funk, 1964.
- Sonn, Albert H. Early American Wrought Iron. 3v. New York: Charles Scribner's Sons, 1928.
- Stern, E. George. Nails -- Definitions and Sizes: A Handbook for Nail Users. Blacksburg, Virginia: Virginia Polytechnic Institute Research Division, 1967.
- Tryon, Rolla M. Household Manufactures in the United States, 1640-1860. Chicago: University of Chicago Press, 1917.
- Tunis, Edward. Colonial Craftsmen and the Beginnings of American Industry. Cleveland, Ohio: The World Publishing Co., 1965.
- Watkins, C. Malcolm. The Cultural History of Marlborough, Virginia. Washington, D. C.: Smithsonian Institution Press, 1968.
- Watson, Aldren A. The Village Blacksmith. New York: Thomas Y. Crowell Co., 1968.
- Weiss, Harry B. and Grace M. Forgotten Mills of Early New Jersey. Trenton: New Jersey Agricultural Society, 1960.
- Weiss, Harry B. and Grace M. Trades and Tradesmen of Colonial New Jersey. Trenton, New Jersey: The Past Times Press, 1965.
- Williams, Henry L. and Ottalie K. Old American Houses. New York: Coward-McCann, Inc., 1957.

III. Public Documents:

Hening, William, ed. The Statutes at Large; Being a Collection of All the Laws of Virginia. 13v. Richmond, New York, Philadelphia: 1810-28.

Palmer, William P., et al., eds. Calendar of Virginia State Papers and Other Manuscripts, 1652-1869. 11v. Richmond: Commonwealth of Virginia, 1875-93.

IV. Unpublished Materials:

Buchanan, Paul. "Nails." Colonial Williamsburg Architectural Research Department, 1968.

Dill, Alonzo T., Jr. "A Documentary History of the Governor's House at New Bern, N. C." Submitted to Perry, Shaw, Hepburn, Kehoe, and Dean, Architects, and The Tryon Palace Commission, The Department of Conservation and Development, State of North Carolina, 15 June 1953.

Gill, Harold B., Jr. "The Blacksmith in Colonial Virginia." Colonial Williamsburg Research Department Report. October, 1965.

Jerdone, Francis. Cargo Waste Book, 1748-49 (microfilm). Reel M118. Colonial Williamsburg Research Department.

Henry Knox Papers, XXXVII (microfilm). Boston: 1960.

Nelson, Lee H. "Nail Chronology as an Aid to Dating Old Buildings." Paper read before National Park Service Historic Structures Training Conference, Philadelphia: 10 August 1962.

V. Periodicals:

Bear, James A., Jr. "Thomas Jefferson -- Manufacturer." The Iron Worker, XXV, No. 4 (Autumn, 1961), 1-9.

The Builder's Magazine, or, Monthly Companion for Architects, Carpenters, Masons, Brick-layers, etc., I (1774). (London).

Chapin, J. R. "Among the Nail Makers." Harper's New Monthly Magazine, XXI, No. CXXII. (July, 1860), 145-64.

The Chronicle. Vols. XII-XVII. Williamsburg: The Early American Industries Association, 1959-64.

Giddens, P. H. "Trade and Industry in Colonial Maryland, 1753-69." Journal of Economic and Business History. IV (1932).

The Lower Norfolk County Virginia Antiquary. Vols. I-V. Richmond, Virginia: Whittet and Shepperson, 1895-1906.

Mercer, Henry C. "The Dating of Old Houses." A Collection of Papers Read Before the Bucks County Historical Society. V. (1926), 536-549.

Peterson, Charles E. "Burning Buildings for Nails." Journal of the Society of Architectural Historians, IX, No. 3. (October, 1950), 23.

Tyler's Quarterly Historical and Genealogical Magazine. V, No. 3. (January, 1924), 168.

Virginia Gazette, 1736-1780. Williamsburg, Virginia: Various Publishers.

The Virginia Historical Register and Literary Companion, VI, No. 1. (1853).

Virginia Magazine of History and Biography. Vols. I-IXXVI. Richmond: Virginia Historical Society, 1893-1968.

William and Mary Quarterly. Series I, XXIII-Series II, X. Williamsburg, Virginia: College of William and Mary, (1914-1930).

VITA

John Tracy Keene, Jr.

Born in Gloversville, New York, April 5, 1947. Graduated from Gloversville High School, June 1965. Undergraduate major in history at Bowdoin College, Brunswick, Maine. A. B. magna cum laude, June 1969.

In June 1969, the author received an appointment as Apprentice in the Interpretation of Historical Sites at the College of William and Mary in cooperation with Colonial Williamsburg. Entered Master of Arts program in the Department of History at the College of William and Mary, September 1969.